

NATIONAL AIR INTELLIGENCE CENTER



NEW DEVELOPMENTS ABROAD IN SPACE FLIGHT CONTROL TECHNOLOGY

by

Chen Zugui



Approved for public release:
distribution unlimited

DTIC QUALITY INSPECTED 3

19961024 064

HUMAN TRANSLATION

NAIC-ID(RS)T-0365-96 1 October 1996

MICROFICHE NR:

NEW DEVELOPMENTS ABROAD IN SPACE FLIGHT CONTROL TECHNOLOGY

By: Chen Zugui

English pages: 25

Source: CASC International Technical Exchange Reports,
Nr. 1, 1995, (China Astronautics and Missilery
Abstracts,)Vol. 2, Nr. 5, 1995; pp. 140-149

Country of origin: China

Translated by: Leo Kanner Associates
F33657-88-D-2188

Requester: NAIC/TASS/Scott D. Fairheller

Approved for public release: distribution unlimited.

<p>THIS TRANSLATION IS A RENDITION OF THE ORIGINAL FOREIGN TEXT WITHOUT ANY ANALYTICAL OR EDITORIAL COMMENT STATEMENTS OR THEORIES ADVOCATED OR IMPLIED ARE THOSE OF THE SOURCE AND DO NOT NECESSARILY REFLECT THE POSITION OR OPINION OF THE NATIONAL AIR INTELLIGENCE CENTER.</p>

<p>PREPARED BY:</p>

<p>TRANSLATION SERVICES NATIONAL AIR INTELLIGENCE CENTER WPAFB, OHIO</p>
--

NEW DEVELOPMENTS ABROAD IN SPACE FLIGHT CONTROL TECHNOLOGY

BY: Chen Zugui

ABSTRACT

This article introduces achievements over the past few years and the direction of developments in the major fields involving space control technology at the 12th Conference on Space Automated Control. It emphasizes a description of ground testing technology of space vehicle GNC systems, space vehicle autonomous control technology, space robot technology and mechanical arm technology as well as flexible space vehicle control technology and GPS navigation technology. Finally it concludes with an introduction of experiences and lessons of several foreign space vehicles and recommendations for China's space platforms and modularizing mode control systems.

KEY WORDS: Space control, system simulation, sensor, positioning system, space robots.

I. Forward

The 12th Session of the Space Vehicle Automated Controls of the International Society of Automated Controls (IFAC) was held outside of Munich, Germany. Attending this conference were scientists and engineering specialists from more than 20 nations and regions including the United States, England, France, Russia, Italy, Canada and China. The conference received 91 academic reports, including seven from China. The conference reported on the breakthroughs and advances in the fields of space control technology and the new directions in which space flight technology was headed. This paper will introduce the primary presentations at the conference and the future direction of space control

technology.

II. The development, testing and simulation of pace vehicle GNC system technology

1. Introduction

The French Matela (phonetic) Space Corporation introduced the state of development of the system testing and simulation technology in the space vehicle attitude and orbit control system (AOCS) being developed by the European Space Bureau. The AOCS subsystem is sometimes called the guidance, navigation and control (GNC) subsystem. It is one of the major subsystems of a space vehicle. Very stringent functional demands are placed on this subsystem. The connections of this subsystems with other subsystems is very complicated, so the development of this subsystem has continued to draw a great deal of attention by agencies of space technologies in many countries. In order to ensure the subsystem's capabilities and reliability during the development process, system testing and simulation has attracted even more attention.

During the seventies, attention was primarily paid to the simulation of the actual space vehicle AOCS system, and semi-actual system. Examples of this are the single axis air flotation platform developed by the Matela (phonetic) Corporation for the AOCS system for the OTS satellite and the triaxial servo platform developed by the MBB Corporation for the Symphony Satellite, both of which were AOCS testing equipment of this period. During simulation with the single axis air flotation platform it was possible to perform total actual simulation of the pitch channel. The characteristics of testing using the triaxial servo platform were that all the attitudes sensors installed on this platform

could conduct triaxial semi-actual simulation testing. As AOCSS subsystems are required to become more precise and more complex, modular AOCSS subsystem simulation technology is being developed. The characteristics of this technology is that it uses high speed standardized computers for timed simulation of satellite kinematics and orbital kinematics, thus not requiring complex actual simulation equipment. The key to this are sensors such as infrared earth sensors, solar sensors and stellar sensors to be modularized for physical simulation. This simulation technology can with minor modifications meet the testing requirements for space vehicle AOCSS systems.

2. Some typical AOCSS simulation testing systems

(a). The OTS attitude and orbital control system testing equipment

Fig. 1 Principles of OTS satellite attitude and orbital control simulation

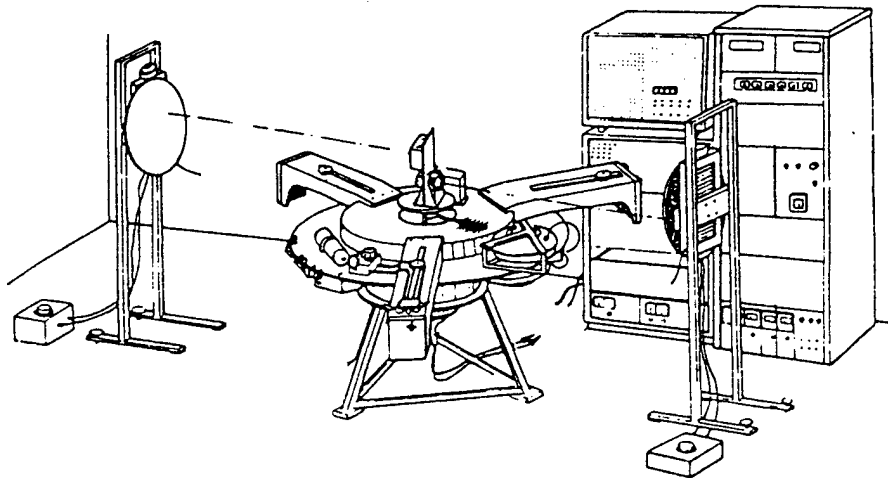
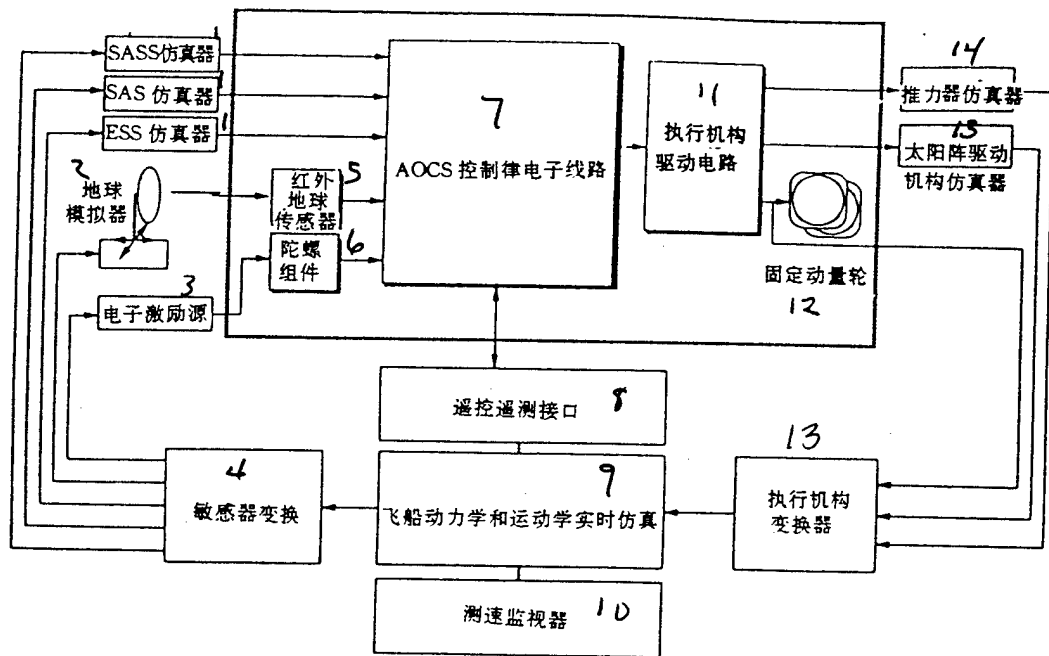

Figure 1 is a diagram of the principles of OTS satellite attitude and orbital control subsystem simulation. In this figure a single axis air flotation platform is used to simulate the attitude kinematics of a satellite. On the platform is an infrared earth sensor and an actuator momentum wheel. Using this equipment it is only possible achieve simulation of the pitch axis control system.

(b). Simulation of the AOCS system of the EUROSTAR satellite

Fig. 2 Diagram of principles of EUROSAT AOCS system simulation



1. Simulator.
2. Earth simulator.
3. Electronic Stimulator.
4. Sensor Switch.
5. Infrared earth sensor.
6. Gyroscope.
7. AOCS control rate circuitry.
8. Remote control and testing port.
9. Live time simulation of vehicle dynamics and kinematics.
10. Velocity monitor.
11. Actuator drive circuit.
12. Fixed flywheel.
13. Actuator switch.
14. Booster simulator.
15. Solar array drive simulator.

The principles of the EUROSTAR AOCs are shown in the block diagram in Figure 2. We can see from this illustration that the infrared earth sensor uses an earth simulator to provide an infrared radiation source, that is actual simulation. The gyroscope assembly is a highly precise constant flow which provides rate information and is a fairly simple attitude sensor. Electronic simulators are used in place of the solar array solar sensor (SASS) and the solar acquisition sensor (SACC). In its output, only the momentum wheel is a physical reality, the solar array drive motor and jet actuator are simulated by direct use of electronic signals. The AOCs control rate electronics equipment is still actual. The overall system has live time switching through space vehicle mechanics and kinematics simulators. This type of simulation technology is the so-called modular simulation technology, and will have widespread uses in the future.

(c). SPOT attitude and orbital control system simulation

Because the ACOS of the SPOT and ERS satellites is a new control system with an on-board computer accomplishing the task of attitude control and orbital control. There are some special characteristics of its simulation testing. The testing uses two flying platforms, an earth sensor mounted on a dual axis platform and a solar sensor installed on triaxial flight platform. The two platform are both controlled by ground simulation computers. The gyroscope is not installed on the flight platform, but a constant current source is used to simulate the angular velocity of space vehicle rotation. The reason for this is that the SPOT attitudinal control is highly precise, and if ground testing is done on a rotational platform, when the platform turned, it would be difficult to eliminate the effects of the velocity of the earth's rotation, but with electrical signal simulation, it is easy to have high precision, and during simulation, with the exception of the

jet actuators everything else is actual to allow the system to come as close as possible to actual flight conditions to ensure the system capabilities meet the demands of actual flight and to ensure the safety and reliability of the system.

3. Key simulation testing equipment

(a). Dynamic simulators

(1). Single axis and triaxial air flotation platforms. The attitudinal motion of the space vehicle is expressed through an air flotation bearing support of the flight platform. It is a piece of test equipment which began to be developed in the sixties. It is suitable for rigid satellites and testing simple AOCs systems.

(2). Single axis or triaxial mechanical rotating platforms. This type of testing equipment can test the AOCs systems of more complex space vehicles. However, they can only perform actual simulation tests. This is because the movement of the platform surface is under the control of the dynamic and kinematic models of a ground simulation computer. Therefore, the actuator control moment cannot be used directly on the flight platform, but is transmitted to the simulation computer by the actuator switch moment, thus closing the system. This system equipment is complex, but is still widely used.

Finally I would like to point out that because of the developments in high speed computers, it is not necessary to demand actual physical simulation, but computer simulation can be used for satellite dynamics and environmental modelling. It provides a sensor and excitation signal for the use of a four element method to describe the satellite attitudinal dynamics. The use of this method to replace attitudinal simulators is something worth looking

into.

(b). Sensors and actuators

Sensors include infrared earth sensors, solar sensors and stellar sensors as well as gyroscope instruments. The earth sensor design is very complex, and modelling precision is poor. Therefore, an earth simulator has continued to be used. The earth simulator is shown in Figure 3. This type of earth simulator is used for low orbit earth satellite. It uses a two axis rotating platform to simulate the pitch and roll motion of the vehicle. It uses a cold plate and hot plate to simulate the infrared horizon transition.

Figure 3. Earth sensor

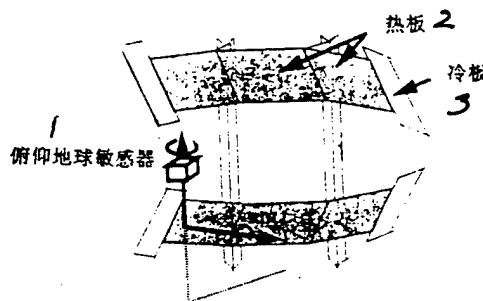

1. Pitch earth sensor. 2. Hot plate. 3. Cold plate.

Figure 4 is a solar emulator used for simulation. It is used to test high precision digital solar sensor. The light source passes through parallel light tubes becoming parallel light used to simulate sunlight. A two axis motor driven rotating platform simulates the rotation of the satellite in relation to the sun's rays.

Fig. 4 Solar simulator

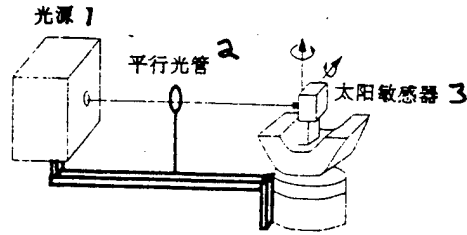

1. Light source. 2. Parallel light tube. 3. Solar simulator.

Fig. 5 Stellar simulator

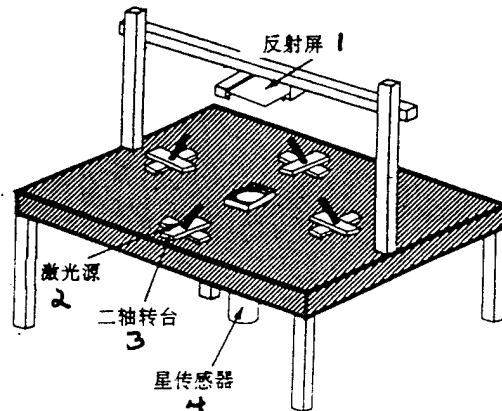

1. Reflection screen. 2. Laser light source. 3. Two axis rotating platform. 4. Stellar sensor.

Figure 5 is a stellar simulator. It can simulate the motion of four different stars at the same time. Another fairly complicated stellar simulator is the stellar space simulator. It simulates the entire stellar which may be seen by the sensor. The first type of stellar sensor is widely used because it is simple and highly precise. The gyroscope simulator is difficult to model, so a real gyroscope is used in the control circuit. The basic

methods of simulation are to introduce a highly precise constant current into the gyroscope circuit. The gyroscope can also be placed on a triaxial flight platform for simulation.

The jet executor is generally replaced by a concise model. With the exception of the cold air executor, simulation testing laboratories do not use actual hot air engines for actual simulation.

For the fixed flywheel and the reaction wheel are used without exception to measure the velocity or current to derive the control moment. If the wheels are not in a vacuum, they must be placed in a vacuum chamber for the testing.

There are three possible methods of simulating solar array drive mechanisms. One is the digital model simulation, the second is to use an actual solar array drive mechanism with a negative load, and the third is to use an actual solar array drive mechanism but without a negative load.

4. Developmental trends in AOCs system testing technology

(a). The modularization and standardizing of the subsystem testing allows it to be easily adapted to new control systems such as the testing and simulation technology for the guidance navigation and control systems which will be developed in the near future.

(b). The live time total computer simulation technology for spacecraft dynamics and kinematics, and the use of this to replace the flight platform required for actual simulation of spacecraft dynamics.

(c). Spacecraft autonomous rendezvous and docking, space

acquisition and space robot simulation research and large actual simulation motion simulator research.

III. Application of inertial guidance systems and GPS/GLONASS combination guidance technology in return and reentry control

1. Introduction

Inertial guidance systems have the advantages of strong autonomy, resistance to interference and high short term guidance precision. They are widely used in aviation, space and ocean navigation. However, gyroscopic shift and accelerometer error built up over time will result in a drop over time in the precision of inertial guidance systems. However, because manned spacecraft require guidance precision within meters and velocity precision in centimeters per second and because they remain aloft for days or months at a time, the use of only a purely inertial navigation system (INS) is not enough. There must be other types of supplementary navigation equipment to make up for inertial navigation error. Looking over current navigation technology we find that satellite navigation systems are the only option. As far as we know there are two types of these systems. One is the United States Global Position System (GPS) and the other is the Russian GLONASS satellite navigation system. A combination navigation composed of INS and GPS/GLONASS is a navigation system with a future of widespread applications and uses on EXPRESS missions.

2. Satellite navigation systems

The Global Positioning System (GPS) is composed of 24 satellites. Three of these are spares. These satellites are arranged on six orbital planes. There are three satellites on each orbit which are angularly equidistant apart. The orbits are 20186

kilometer circular orbits. Each satellite transmits navigation signals including the satellite time. The customers receive the navigation signals from the satellite, compare the times, and from the difference between the time the satellite transmitted the signal and the time the customer receives the signals is the speed of light, so it is possible to find the distance from the navigation satellite and the customer. The location of the navigation satellite can be found from its schedule, with a precision of better than five meters. In theory only three navigation satellites are required to provide a fix on the customer's location (X,Y,Z), but because of the use of customer clock frequency shift, information from four navigation satellites are required to properly determine the customer's location. The GPS positioning principle is shown in Figure 6.

Fig. 6 Principle of GPS navigation positioning

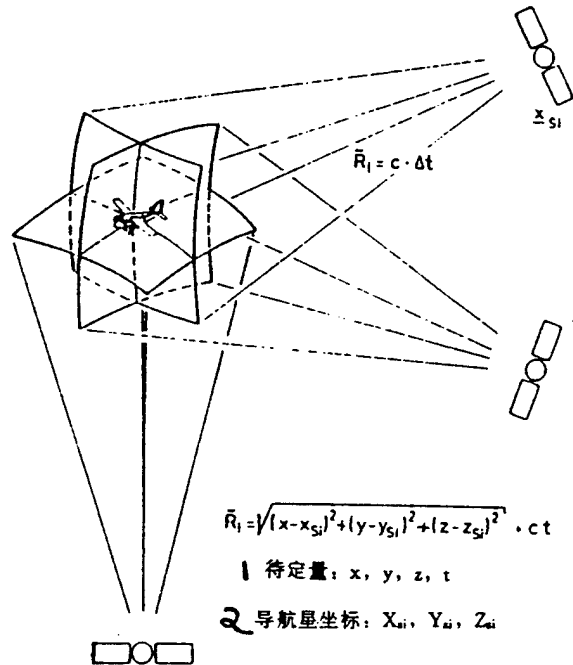

1. Special values. 2. Navigation satellite coordinates.

3. Environmental conditions of spacecraft reentry

GPS navigation systems can be used on geographical targets, and for navigation and positioning by aircraft and low orbit space vehicles. Because navigation satellites are in a circular orbit with a radius vector of 201680 kilometers, there is no great difference between the GPS applications for these three types of customer from the viewpoint of geometry. However, there is a big difference in the dynamic environments of these different applications, so they have different requirements for GPS reception. The environmental conditions of these different customers are listed below:

FIELD OF APPLICATION	VELOCITY (M/S)	ACCELERATION (G)
SURFACE (SURVEYING)	0	1
SURFACE (VEHICLE)	60	<3
AVIATION	<600	<6
SPACE	>7800	<15

We can see from this that the velocity of aviation flight is only several hundred meters per second, but space flight velocity is greater than 7800 meters per second, and that while aviation acceleration is less than 6g, for a space vehicle at reentry it can exceed 15g. Tests have demonstrated that at acceleration of $3m/s^2$, the greatest velocity measurement error caused by GPS response is 14 meters per second, and the maximum positioning error is 240 meters, and these two errors are directly proportional to acceleration. Because acceleration can reach 20g during reentry, it is very important to increase the dynamic capabilities of GPS during reentry, and at the same time the GPS receiver used for reentry control requires that the navigation computer have a fast calculation speed.

Another major problem in satellite navigation system application is the loss of the navigation signals. Loss of the GPS navigation signal by a reentry vehicle is primarily due to the following causes:

(1). Black obstacles. When the reentry vehicle is being braked by atmosphere resistance, kinetic energy is converted into heat energy, causing ionization of the air surrounding the vehicle, causing an ionized field around the reentry vehicle. because an ionized field acts as a shield against electromagnetic wave, this results in signal loss by the GPS receiver.

(2). Reentry space vehicle rotation causes the antenna to be blocked.

(3). Another problem with use for reentry is high temperature. Temperatures can reach 2500K during the reentry process. Therefore, heat protection and thermal design of the antenna is extremely important.

4. Reentry vehicle INS/GPS navigation systems

In order to use the high precision properties of GPS and the advantages of autonomy and strong resistance to interference of INS, the SPACENAV combination navigation system was developed for the German/Japanese EXPRESS reentry vehicle. Its operational principles are as follow: Use the GPS navigation information to set the error model of the inertial guidance system before black obstacles are generated. During the time of black obstacles use the post-indicated INS system for pure inertial navigation. After black obstacles have appeared, if the GPS antenna is still whole, then acquire the navigation satellite once more and continue to use GPS navigation. However, aerodynamic control of the landing point

is very limited at this time. This is because the precision of the entire system is very much tied to the black obstacle zone inertial navigation system capabilities. The size of the black obstacle zone and the control precision of the mass and return landing point indicated by the error modelling determines the selection of the gyroscope inertial guidance system.

4. Developmental trends

There will be widespread uses of INS/GPS combination navigation in return reentry type space vehicles (including space shuttles). However, in order to improve the precision of the guidance there must be a precision guidance reference. This requires that the INS provide precise attitude reference. In addition to using a high precision high stability gyroscope (such as a laser gyroscope), the use of a stellar sensor to provide high precision attitude reference and for INS in orbit reference are major developmental directions. This is the use of a combination navigation system composed of stellar sensors, GPS and INS. This type of system has highly precise navigation and high reliability, and should draw a great deal of attention from China's experts conducting research into space control technology.

IV. Space vehicle autonomous control technology

Another major topic in the field of space control discussed at this conference was design problems of fully automatic space vehicles and autonomous flight vehicles. From the viewpoint of aviation, fully automated commercial aircraft will have to be developed during the 21st century. The reasons for this are:

1. Aircraft safety and reliability

According to safety requirements, safety should be $5 \times 10^{-8}/h$, and current pilots even when they are checked twice a month can only attain $10^{-6}/h$

2. Air traffic control safety

At the present time, in-air collision disasters (due to air traffic controller error) occur at the rate of three a year in the United States and Europe. There are currently some 7500 commercial aircraft. By 2008 to 2018 this number will double. If the level of in-air collisions is to be only one per year at this time is to be attained, it will require the air control system safety to be at least tripled.

3. Man is less reliable than machines, especially digital computers. The less the pilots interfere with control systems, the better the systems operate. Because the system is complex, if the pilot is required to intervene within a few seconds time, he will not be able to know the status of the system and make the proper decision. It is estimated that in 15 to 20 years there will be automated aircraft. In fully automatic aircraft, there will still be people on board, will help in the recognition and handling of problems, and will also help in the improvement of future systems.

Automation will attract even more attention for space vehicles. On one hand, due to the development of application satellites, the number of satellites flying around in space has increased, increasing the demands on earth monitoring and control stations. These are limited by the ground control capabilities and the cost involved. Therefore, the problem of reasonable division of missions between ground stations and satellite systems has come up, and demands will be made for automation of space vehicles. On the other hand, in order to assemble large space structures, develop

space exploration devices and devices to explore the surface of planets, a space mechanical arm, robots and unmanned space vehicles must be developed. This requires automated systems which must be able to go for long periods of time without man intervening and be able to complete selected movements. In order to make decisions in order to handle unforeseen situations, it will require high level deduction. This involves self learning and so-called intelligence. So called intelligence autonomous systems are systems which have the ability to organize themselves, manage themselves and thus learn. Intelligent autonomous systems are called IAV systems. IAV system logic involves such fields as artificial intelligence, operational research, software engineering and control theory. At the present time there is an urgent hope for the establishment of a theoretically complete, effective connection as well as the development of theories and standards for an IAV system which everyone can accept. This is currently the primary direction of attack in intelligence autonomous space technology.

For analysis of autonomous systems, the C method has been proposed. This is dividing the overall system into three subsystems. The IAV system has three primary substructural elements. These are:

(a). The System architecture. This is used to determine the connections of the functions and capabilities of the different systems and switching back and forth between the different elements.

(b). System processing package sensor information processing (sensor= sensor data merging= form evaluation and recognition), modelling and mission planning (planning= navigation= piloting (guidance)= servo control).

(c). System management substructure. This is used to manage the system mission and processing and to coordinate and command.

Concerning intelligent control technology, this conference introduced the structural methods of intelligent control, the purpose of intelligent controllers is to make the most of human intelligence, innovation and the capability of processing complex tasks under conditions of a changing environment and a changing mission, and at the same time avoid man's inconsistencies. Intelligent control design ordinarily uses a graduated, nested structure. This article will introduce three different three layered structures, the planning layers, the navigation layers and the pilot layers. Intelligent control systems should have the following major characteristics: Can be corrected, robustness, can be extended, can be used for repeated applications and be compatible.

In addition to these applications, development in intelligent autonomous control technology should pay a great deal of attention to the application of IAV technology in space rendezvous and docking missions. The European Space Bureau has done a great deal of work in this area. Because of limited ground monitoring and control capabilities, autonomous rendezvous and docking is a very promising avenue for China's future space rendezvous and docking.

V. Flexible space vehicle dynamics and control technology

Large space flexible structure dynamics and control is one direction of research and development in space vehicle control technology. A great deal of attention was paid to this field at this conference.. There was a group which was dedicated to reports and discussion on this topic. Mister M. Seltzer from the United

States presented a summary report, and more than ten papers on this were read at the conference.

The first thing that must be done in flexible space vehicle control systems is to analyze the capability index demands and the technology indexes. Design technology indexes will last of all be demonstrated in flight testing. In the process of development the capability indexes of the system must be anticipated. The methods of anticipating these include:

(1). Analysis

This is the engineering and mathematical analysis of the system to anticipate the system stability, vibration inhibition, turbulence elimination, target acquisition, reacquisition and redirection finding capabilities.

(2). Computerized or actual simulation.

(3). Ground hardware design. This equipment is used to study the dynamic properties of flexible space vehicles. Such equipment includes the active space structure hardware, simulation software and the various instruments.

(4). Suborbital flight testing. This includes falling tests from high towers or weightlessness aircraft testing.

(5). Orbital flight testing. All of the previous testing is simulation. Only the orbital flight is the final testing. However, the costs are very expensive. A typical orbital flight testing equipment is a space shuttle.

(6). In-orbit redesign. If the flexible space flight vehicle

control system does not meet design standards during orbital flight, it is possible to modify or redesign the system to make the system capabilities meet use requirements.

There are three basic methods of modelling flexible space vehicle systems. (1), is to use the laws of physics to derive the mathematical model. (2), is to use limited element methods to construct a digital model. (3), is to use system recognition (IO) methods to establish a digital or mathematical model from experimental data. The flexibility dynamics models established using the limited element analysis or system recognition methods are highly dimensional, and require dimensional reduction, so model reduction occurs.

Flexible space structure control system design makes wide use of current control theory design methods. These include: Linear secondary model control design methods, polar arrangement method, high authority control/low authority control, maximum entropy and optimal projection methods, infinite H (H^∞) method and the digital mode design method. It is also possible to use classic control design methods to design flexible space vehicle control systems.

Professor G. Grubel of the German Space Research and Testing Academy Institute of Flight System Dynamics made a report entitled "Large Space Structure Multivariable Robustness Controller. The conference also organized a tour to this institute's Large Space Structure Laboratory. This lab uses a suspended flexible body for a great deal of research and testing concerning large space structure control technology with breakthrough results. This made a great impression on the space control experts from all the countries.

VI. Space robots and mechanical arms

Without any doubt, space robots and mechanical arms are an important field of research in the high technology of space. Furthermore, space remote controlled mechanical arm systems have already been used successfully in space shuttles. Canada's J. Z. Sasiader presented a report entitled "Space robots and mechanical arms: past experiences and future tasks and systems."

1. Robots and mechanical arms

Space exploration requires widespread use of robots. This was true in the past and it will be true in the future. Space robots are divided into: Mobile robots, flight vehicles and robots, and mechanical arms. Three methods can be used to control robots in space. Manual control, automatic control and remote control.

The first space robot was a remote mechanical arm system (RMS) installed aboard the space shuttle. It had six degrees of freedom, three elevations, and three yawing and rolling motions. The second space robot was a remote mechanical arm designed for the Russian Space Station, the (SSRMS). A special flexible arm was also designed for this space station, it has seven degrees of freedom. it is 1.99m long.

2. Practical experience in space in mechanical arm design

The experiences gained by the space shuttle mechanical arm design are: (1), the mechanical arm speeds should be greatly improved. (2), one of the greatest problems in using the mechanical arm is its positioning precision. (3), the mechanical arm should have passive vibration control capability. (4), in order to improve the positioning precision and reduce the stability

time, it is necessary to increase passive vibration control. (5), adding new force control circuits can greatly improve the properties of the mechanical hand.

3. Future tasks and systems

The missions of the Russian Space Station have provided new demands on robots and mechanical arms. These demands are summarized below:

The space station remote control mechanical arm (SSRMS) can lift 11,600 kilograms and has a peak movement speed of 0.37 meters per second. Positioning precision is 4.5 centimeters.

The special flexible mechanical arm (SPDM) is a robot with two arms. Placed at the top of the SSRMS it has a load capacity of 600 kilograms. It has a positioning precision of 0.6 centimeters. The SPDM control system is a complex system. It involves simultaneous positioning and power control of both arms for complex missions and difficult environment.

The developmental directions for future space robot technology are: Space robot autonomous control, widespread use of remote control robots, improved capabilities of positioning and force control systems, developing new free flight robots, design of new autonomous robots for exploring planets.

VI. New achievements in space vehicle attitude control technology and flight testing results

1. Experiences in handling the ROSAT satellite malfunction

W. Schrempp of the MBB Corporation provided a briefing on the

experiences in handling the malfunction of the ROSAT satellite. This was the use of software to restore the satellite operations after a hardware malfunction. This is a valuable reference for handling malfunctions on application technical satellites.

The ROSAT satellite was launched on June 1, 1990. After launch the attitude metering and control system (AMCS) operated normally for seven months. After seven months, due to a stellar sensor malfunction, the Y coordinate gyroscope became ineffective, and the functions of the X and Z coordinate gyroscopes were seriously degraded. The diagonal gyroscope was also off. All of this had a serious effect on the overall system, and finally led to cessation of the normal missions.

Through ground simulation, the attitude of the satellite was determined using information from a solar sensor and magnetometer, and the attitude metering and control system computer was reprogrammed. The gyroscope shift and the scale factor error calibrated on the ground were entered into the computer aboard the satellite for compensation. The constant star acquisition sequence was redesigned and the stellar map recognition strategy and with less than three gyroscopes, accomplished the ROSAT satellite directional control, finally reestablishing normal operational attitude of the satellite. The overall recovery operations took five months. This is an example of a satellite control system being restructured to successfully salvage a satellite. The most important thing in this operation was that during the design of the stem there should be system restructuring methods. Here it refers to the command computer software entry and reprogramming capability.

2. The application of modularized attitude control systems in OTPEX/POSEIDEN (T/P) missions :

NASA's Goddard Space Flight Center developed a corresponding modularized attitude control system (MACS) for multiple function modularized space vehicles (MMS) in the seventies. Because of the development of multiple function modularized space platforms and the development of the corresponding modularized attitude control systems was of major significance for improving the reliability of satellites, of reducing development costs, of accelerating the development cycle, making it suited for application satellites which were becoming more in demand in the domestic and foreign market.

(a). System structure

The MACS was composed of modular parts. These included: Standardized inertial reference elements (DRIRU) standardized stellar tracking, reaction wheel assembly, triaxial magnetometer, on-board computer, magnetic devices and earth sensors and digital or solar sensors. What needs to emphasized is that to modularize attitude control systems, it was necessary to develop modularized components. It would be very difficult to improve component and system reliability without changing the status of the technology.

(2). Strict developmental flow

Design, production and testing all followed strict rules.

(3). Tight and detailed surface testing and demonstration

Ground testing is fairly important in improving the

reliability of space vehicles. Necessary ground testing has to be done. For the MACS of the T/P mission, it was stipulated that the following ground testing be done: Hardware testing and demonstration, software checks, analytical simulation

Hardware testing was conducted at four levels - the component level, the system level, the multiple function modularized platform level and the overall satellite level. The component level testing and demonstrate was conducted in strict adherence with regulations. The testing included environmental testing and technological capability testing. The MACS system level testing included installation, remote control and remote metering connection testing as well as limited function capability demonstration testing. There were detailed rules and regulation for the installation of each component, and installation included positioning.

When installation was completed, capability testing was performed by system. The testing was done in strict adherence to the MACSPERF. This stipulated checking 24 items. The testing was done automatically and the language used was standard testing operational language (STOL). In addition to capability testing, it was also necessary to conduct polarity tests and phasing tests, which were conducted in accordance with MACSPHA, with the executor output checked from the sensor input, ensuring the controls were positive and accurate.

The MMS level tests. When conducting this test, the MACS module and modularized power source subsystem (MPS), the communications and data handling module (C&DH), the propulsion module (PM) and the earth sensor module (ESAM) were all installed on the modular support structure (MSS), and was tested on this structure. The tests done here were the capability tests and the polarity tests.

The last tests were the overall satellite tests. The overall satellite tests were conducted combining the MMS and instrument modules (IM) A625 and A627 with elevation and yawing solar sensors installed. In addition to the overall testing of the MMS level, the overall satellite testing also required testing with solar array control. The entire satellite underwent environmental testing.

The software testing was divided into four levels: The engineering testing used FORTRAN language, the second level used NASA standard computer compiler language, checking precision and bit length. The third level used flight software checks. The most stringent four level software check was done using software development SOFV.

System capabilities refers to using analysis and simulation to anticipate error and stability. We stress here that simulation is the triaxial live time digital simulation. It appears that it is perfectly possible not to use flight platform simulation of MMS. Because this type of testing has already been done when system development begins, and because conclusions have already been reached, when this MACS is used on other flight missions it is not necessary to do actual simulation. This is economical and can accelerate the progress of development.

We can see from this introduction that the development of MMS multiple function platform is a major technical avenue for improving space vehicle reliability and accelerating developmental progress of the space vehicle.