

FINAL REPORT
FEBRUARY 1996

REPORT NO. 96-13

NEW MANUFACTURERS OF
WOODEN PALLETS UTILIZING
MECHANICAL NAILERS
MIL-STD-1660 TESTS

19961104 112

Prepared for:
U.S. Army Armament Research, Development
and Engineering Center
ATTN: AMSTA-AR-ESK
Rock Island, IL 61299-7300

Distribution Unlimited



VALIDATION ENGINEERING DIVISION
SAVANNA, ILLINOIS 61074-9639

DTIC QUALITY INSPECTED 1

DISCLAIMER NOTICE

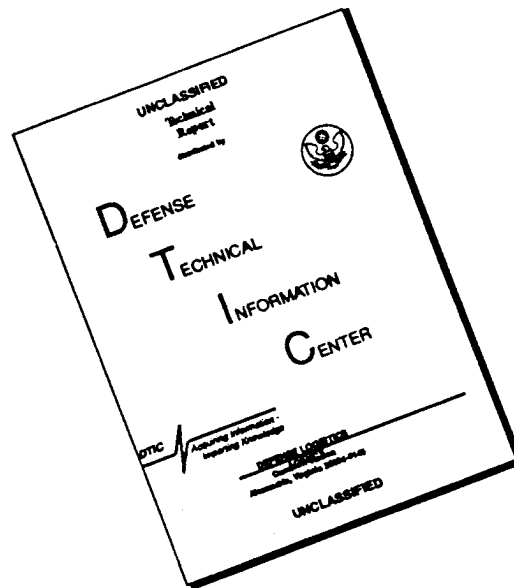

THIS DOCUMENT IS BEST QUALITY AVAILABLE. THE COPY FURNISHED TO DTIC CONTAINED A SIGNIFICANT NUMBER OF PAGES WHICH DO NOT REPRODUCE LEGIBLY.

AVAILABILITY NOTICE

A copy of this report will be furnished each attendee on automatic distribution. Additional copies or authority for reprinting may be obtained by written request from Director, U.S. Army Defense Ammunition Center and School, ATTN: SIOAC-DEV, Savanna, IL 61074-9639.

DISTRIBUTION INSTRUCTIONS

Destroy this report when no longer needed. Do not return.

Citation of trade names in this report does not constitute an official endorsement.

The information contained herein will not be used for advertising purposes.

REPORT DOCUMENTATION PAGE				Form Approved OMB No. 0704-0188	
1a. REPORT SECURITY CLASSIFICATION UNCLASSIFIED			1b. RESTRICTIVE MARKINGS		
2a. SECURITY CLASSIFICATION AUTHORITY		3. DISTRIBUTION / AVAILABILITY OF REPORT UNLIMITED			
2b. DECLASSIFICATION / DOWNGRADING SCHEDULE					
4. PERFORMING ORGANIZATION REPORT NUMBER(S) 96-13			5. MONITORING ORGANIZATION REPORT NUMBER(S)		
6a. NAME OF PERFORMING ORGANIZATION U.S. Army Defense Ammunition Center and School		6b. OFFICE SYMBOL (if applicable) SIOAC-DEV	7a. NAME OF MONITORING ORGANIZATION		
6c. ADDRESS (City, State, and ZIP Code) ATTN: SIOAC-DEV Savanna, IL 61074-9639			7b. ADDRESS (City, State, and ZIP Code)		
8a. NAME OF FUNDING / SPONSORING ORGANIZATION U.S. Army Armament Research, Development and Engineering Center		8b. OFFICE SYMBOL (if applicable) AMSTA-AR-ESK	9. PROCUREMENT INSTRUMENT IDENTIFICATION NUMBER		
8c. ADDRESS (City, State, and ZIP Code) ATTN: AMSTA-AR-ESK Rock Island, IL 61299-7300			10. SOURCE OF FUNDING NUMBERS		
			PROGRAM ELEMENT NO.	PROJECT NO.	TASK NO.
					WORK UNIT ACCESSION NO.
11. TITLE (Include Security Classification) New Manufacturers of Wooden Pallets Utilizing Mechanical Nailers MIL-STD-1660 Tests					
12. PERSONAL AUTHOR(S) Bradley J. Haas					
13a. TYPE OF REPORT Final		13b. TIME COVERED FROM _____ TO _____		14. DATE OF REPORT (Year, Month, Day) 1996 February	15. PAGE COUNT
16. SUPPLEMENTARY NOTATION					
17. COSATI CODES			18. SUBJECT TERMS (Continue on reverse if necessary and identify by block number)		
FIELD	GROUP	SUB-GROUP			
19. ABSTRACT (Continue on reverse if necessary and identify by block number) The U.S. Army Defense Ammunition Center and School (USADACS), Validation Engineering Division (SIOAC-DEV), was tasked by the U.S. Army Armament Research, Development and Engineering Center (ARDEC) to conduct MIL-STD-1660 tests, Design Criteria for Ammunition Unit Loads, on 42- by 53-inch pallets using commercially available nails installed with mechanical nailers. Pallets were supplied by Madison County Wood Products, Inc. and Stewart's Forest Products, Inc. This report contains test results of pallets provided by each manufacturer meeting MIL-STD-1660 requirements.					
20. DISTRIBUTION / AVAILABILITY OF ABSTRACT <input checked="" type="checkbox"/> UNCLASSIFIED/UNLIMITED <input type="checkbox"/> SAME AS RPT. <input type="checkbox"/> DTIC USERS			21. ABSTRACT SECURITY CLASSIFICATION UNCLASSIFIED		
22a. NAME OF RESPONSIBLE INDIVIDUAL JEROME H. KROHN			22b. TELEPHONE (Include Area Code) 815-273-8929		22c. OFFICE SYMBOL SIOAC-DEV

U.S. ARMY DEFENSE AMMUNITION CENTER AND SCHOOL
VALIDATION ENGINEERING DIVISION
SAVANNA, IL 61074-9639

REPORT NO. 96-13

NEW MANUFACTURERS OF WOODEN PALLETS UTILIZING
MECHANICAL NAILERS MIL-STD-1660 TESTS

TABLE OF CONTENTS

PART	PAGE NO.
1. INTRODUCTION	1-1
A. BACKGROUND	1-1
B. AUTHORITY	1-1
C. OBJECTIVE	1-1
D. CONCLUSION	1-1
E. RECOMMENDATIONS	1-2
2. ATTENDEES	2-1
3. TEST PROCEDURES	3-1
4. TEST EQUIPMENT	4-1
5. TEST RESULTS	5-1
6. PHOTOGRAPHS	6-1
7. DRAWINGS	7-1

PART 1

INTRODUCTION

A. BACKGROUND. The U.S. Army Defense Ammunition Center and School (USADACS), Validation Engineering Division (SIOAC-DEV), was tasked by the U.S. Army Armament Research, Development and Engineering Center (ARDEC), Rock Island, IL, to conduct MIL-STD-1660 tests, Design Criteria for Ammunition Unit Loads, on 42- by 53-inch oak pallets manufactured by Madison County Wood Products, Inc. and Stewart's Forest Products, Inc. The pallets produced by Madison County Wood Products, Inc. utilized commercially available nails installed by a hydraulic nailer. The pallets produced by Stewart's Forest Products, Inc. utilized commercially available nails installed by a Stanley-Bostage pneumatic nailer.

B. AUTHORITY. This test was conducted IAW mission responsibilities delegated by the U.S. Army Armament, Munitions and Chemical Command (AMCCOM), Rock Island, IL.

C. OBJECTIVE. The objective of these tests was to verify that pallets fastened using commercially available nails installed by a mechanical nailer meet MIL-STD-1660 criteria.

D. CONCLUSION. The initial pallets submitted by each manufacturer failed to meet MIL-STD-1660 criteria. Madison County Wood Products, Inc. then submitted pallets with 3-1/4-inch 10 gauge hardened steel nails and 1-5/8-inch 11-1/2 gauge hardened steel nails which passed MIL-STD-1660 testing requirements. Stewart's Forest Products, Inc. submitted pallets utilizing 3-inch nails with a 0.120-inch diameter and 1-1/2-inch nails with a 0.080-inch diameter and pallets utilizing 3-inch nails with a 0.120-inch diameter, 2-1/4-inch nails with a 0.099-inch diameter and 1-1/2-inch nails with a 0.080-inch diameter which passed MIL-STD-1660 testing.

E. RECOMMENDATIONS:

1. According to MIL-P-15011, Revision J, 3.3.3.1, fasteners shall be fastened not less than 3/4-inch from the end and 1-inch from the side edge of deckboards. The remaining fasteners shall be uniformly spaced between them. All the nails attaching the deck boards to the outside stringer boards in pallet group no. 2 are on the inner half of the stringer board. Placing nails closer to the end would reduce the amount of separation that occurs between the end of the deck boards and the edge of the stringer boards.

2. According to MIL-P-15011, Revision J, Figure 5, the 3-1/4-inch-long nails shall be used when nailing the top deck board and stringer board assembly into posts. The pallets supplied by Madison County Wood Products, Inc. contain 3-1/4-inch-long nails fastening only the stringer board to the post. This should not be permitted in production.

PART 2

22 NOVEMBER 1995 - 23 JANUARY 1996

ATTENDEES

Bradley J. Haas
Mechanical Engineer
DSN 585-8336
815-273-8336

Director
U.S. Army Defense Ammunition Center
and School
ATTN: SIOAC-DEV
Savanna, IL 61074-9639

Betty J. Kundert
Engineering Draftsman
DSN 585-8095
815-273-8095

Director
U.S. Army Defense Ammunition Center
and School
ATTN: SIOAC-DES
Savanna, IL 61074-9639

5 AND 7 DECEMBER 1995

Sandra M. Schultz
Industrial Engineer
DSN 585-8086
815-273-8086

Director
U.S. Army Defense Ammunition Center
and School
ATTN: SIOAC-DES
Savanna, IL 61074-9639

5 DECEMBER 1995

Mark Rehmstedt
DSN 793-8206

Commander
U.S. Army Armament Research, Development
and Engineering Center
ATTN: AMSTA-AR-ESK
Rock Island, IL 61299-7300

Kim Wheat
DSN 793-8203

Commander
U.S. Army Armament Research, Development
and Engineering Center
ATTN: AMSTA-AR-ESK
Rock Island, IL 61299-7300

ATTENDEES (continued)

George K. Stewart, Jr.
1-800-233-7835
612-645-8266

Stewart's Forest Products, Inc.
803 Transfer Rd.
St. Paul, MN 55114

7 DECEMBER 1995

Ronald Throm
314-383-5700

Madison County Wood Products, Inc.
5101 Farlin Avenue
St. Louis, MO 63115

PART 3

TEST PROCEDURES

The test procedures outlined in this section were extracted from MIL-STD-1660, Design Criteria for Ammunition Unit Loads, 8 April 1977. This standard identifies nine steps that a unitized load must undergo if it is to be considered acceptable. The four tests that were conducted on the test pallets are summarized below.

A. STACKING TESTS. The unit load was loaded to simulate a stack of identical unit loads stacked 16 feet high, for a period of one hour. This stacking load was simulated by subjecting the unit load to a compression weight equal to an equivalent 16-foot stacking height. The compression load was calculated in the following manner. The unit load weight was divided by the unit load height in inches and multiplied by 192. The resulting number was the equivalent compressive force of a 16-foot-high load.

B. REPETITIVE SHOCK TEST. The repetitive shock test was conducted IAW Method 5019, Federal Standard 101. The test procedure is as follows: The test specimen was placed on, but not fastened to, the platform. With the specimen in one position, the platform was vibrated at 1/2-inch amplitude (1-inch double amplitude) starting at a frequency of approximately 3 cycles per second. The frequency was steadily increased until the package left the platform. The resonant frequency was achieved when a 1/16-inch-thick feeler gage momentarily slid freely between every point on the specimen in contact with the platform at some instance during the cycle or a platform acceleration achieved 1 +/- 0.1 Gs. Midway into the testing period, the specimen was rotated 90 degrees and the test continued for the duration. Unless failure occurred, the total time of vibration was two hours if the specimen was tested in one position and three hours for more than one position.

C. EDGEWISE ROTATIONAL DROP TEST. This test was conducted using the procedures of Method 5008, Federal Standard 101. The procedure for the edgewise rotational drop test is as follows: The specimen was placed on its skids with one end of the pallet supported on a beam 4-1/2 inches high. The height of the beam was increased if necessary to ensure that there was no support for the skids between the ends of the pallet when dropping took place, but was not high enough to cause the pallet to slide on the supports when the dropped end was raised for the drops. The unsupported end of the pallet was then raised and allowed to fall freely to the concrete, pavement, or similar underlying surface from a prescribed height. Unless otherwise specified, the height of drop for level A protection conforms to the following tabulation:

GROSS WEIGHT (WITHIN RANGE LIMITS) (Pounds)	DIMENSIONS OF ANY EDGE, HEIGHT OR WIDTH (WITHIN RANGE LIMITS) (Inches)	HEIGHT OF DROPS ON EDGES	
		Level A	Level B
		(Inches)	(Inches)
150 - 250	60 - 66	36	27
250 - 400	66 - 72	32	24
400 - 600	72 - 80	28	21
600 - 1000	80 - 95	24	18
1000 - 1500	95 - 114	20	16
1500 - 2000	114 - 144	17	14
2000 - 3000	Above 145 - No limit	15	12
Above - 3000		12	9

D. INCLINE-IMPACT TEST. This test was conducted by using the procedure of Method 5023, Incline-Impact Test of Federal Standard 101. The procedure for the incline-impact test is as follows: The specimen was placed on the carriage with the surface or

edge which is to be impacted projecting at least 2 inches beyond the front end of the carriage. The carriage was brought to a predetermined position on the incline and released. If it is desired to concentrate the impact on any particular position on the container, a 4- by 4-inch timber was attached to the bumper in the desired position before the test. No part of the timber was struck by the carriage. The position of the container on the carriage and the sequence in which surfaces and edges are subjected to impacts was at the option of the testing activity and depends upon the objective of the tests. This test is to determine satisfactory requirements for a container or pack, and, unless otherwise specified, the specimen was subjected to one impact on each surface that has each dimension less than 9.5 feet. Unless otherwise specified, the velocity at time of impact was 7 feet per second.

PART 4

TEST EQUIPMENT

A. PALLET GROUP NO. 1 (Test Samples).

1. Size: 42- by 53-inches
2. Pallet Supplier: Madison County Wood Products, Inc.
3. Quantity: 3
4. Weight Loaded: 4,000 pounds
5. Nails: 3-inch with 0.126-inch diameter
1-5/8-inch with 0.120-inch diameter

B. PALLET GROUP NO. 2 (Test Samples).

1. Size: 42- by 53-inches
2. Pallet Supplier: Madison County Wood Products, Inc.
3. Quantity: 3
4. Weight Loaded: 4,000 pounds
5. Nails: 3-1/4-inch 10 gauge steel hardened to
21 degrees miband
1-5/8-inch 11-1/2 gauge steel hardened
to 21 degrees miband

C. PALLET GROUP NO. 3 (Test Samples).

1. Size: 42- by 53-inches
2. Pallet Supplier: Stewart's Forest Products, Inc.
3. Quantity: 3
4. Weight Loaded: 4,000 pounds
5. Nails: 3-inch with 0.120-inch diameter
Tensile Strength: 107,871 psi
Rockwell Hardness (A-scale): 39-46
2-1/4-inch with 0.099-inch diameter
Tensile Strength: 105-135 kpsi
Material: C10B12
1-1/2-inch with 0.080-inch diameter
Tensile Strength: 125-145 kpsi
Material: C1015

D. PALLET GROUP NO. 4 (Test Samples).

- 1. Size: 42- by 53-inches
- 2. Pallet Supplier: Stewart's Forest Products, Inc.
- 3. Quantity: 3
- 4. Weight Loaded: 4,000 pounds
- 5. Nails:
 - 3-inch with 0.120-inch diameter
 - Tensile Strength: 107,871 psi
 - Rockwell Hardness (A-scale): 39-46
 - 1-1/2-inch with 0.080 inch diameter
 - Tensile Strength: 125-145 kpsi
 - Material: C1015

E. PALLET GROUP NO. 5 (Test Samples).

- 1. Size: 42- by 53-inches
- 2. Pallet Supplier: Stewart's Forest Products, Inc.
- 3. Quantity: 3
- 4. Weight Loaded: 4,000 pounds
- 5. Nails:
 - 3-inch with 0.120-inch diameter
 - Tensile Strength: 107,871 psi
 - Rockwell Hardness (A-scale): 39-46
 - 2-1/4-inch with 0.099-inch diameter
 - Tensile Strength: 105-135 psi
 - Material: C10B12
 - 1-1/2-inch with 0.080-inch diameter
 - Tensile Strength: 125-145
 - Material: C1015

F. COMPRESSION TESTER.

- 1. Manufacturer: Ormond Manufacturing
- 2. Platform: 60- by 60-inches
- 3. Compression Limit: 50,000 pounds
- 4. Tension Limit: 50,000 pounds

G. TRANSPORTATION SIMULATOR.

- | | |
|------------------|--------------------|
| 1. Manufacturer: | Gaynes Laboratory |
| 2. Capacity: | 6,000-pound pallet |
| 3. Displacement: | 1/2-inch amplitude |
| 4. Speed: | 50 to 400 rpm |
| 5. Platform: | 5- by 8-foot |

H. INCLINED PLANE.

- | | |
|------------------|--------------------|
| 1. Manufacturer: | Conbur Incline |
| 2. Type: | Impact Tester |
| 3. Grade: | 10 percent incline |
| 4. Length: | 12-foot |

PART 5

TEST RESULTS

PALLET GROUP NO. 1

A. TEST OBSERVATIONS. A hydraulic nailer was used to install the nails in this group of pallets. The nails in these pallets were smaller than those specified in MIL-P-15011, Revision J. The nails fastening the deck boards to the stringer boards are not clinched. No deck separation resulted. Prior to placing the load on the pallet, a portion of the stringer board of pallet no. 2 was separated. Each pallet was loaded with 4,000 pounds of inert boxed ammunition.

B. STACKING TEST. Each test pallet was initially loaded to 14,000-pounds compression. The compression was released after one hour. None of the test samples were damaged.

C. REPETITIVE SHOCK TEST. The duration of the test was 90 minutes for each orientation of the pallet. The transportation simulator was operated for each pallet IAW Table 1 on page 5-2. One steel strap on pallet no. 1 broke from rubbing against the bar that holds the pallet on the vibration table. The band was replaced and testing was continued. One of the corner posts on pallet no. 1 was twisted slightly while the pallet was being removed from the transportation simulator. The lateral orientation of vibration for pallet no. 2 caused one of the outside skids to release from the posts completely, as 7 of the 9 nails fastening the skid to the posts were sheared off (see Part 6, page 6-2). The longitudinal vibration of pallet no. 3 caused one corner of one of the side skids to come loose from the post. The lateral orientation of vibration caused the nails fastening the deck to the post to shear off at one corner of the pallet (see Part 6, page 6-3).

TABLE 1

<u>Pallet No.</u>	<u>Lateral Orientation (rpm)</u>	<u>Longitudinal Orientation (rpm)</u>
1	168	233
2	162	170
3	160	175

D. EDGEWISE ROTATIONAL DROP TEST. Pallet no. 1 was the only sample exposed to this test. Each side of the pallet was placed on a beam displacing it 4-1/2-inches above the floor. The opposite end of the pallet was raised to a height of 12 inches, then dropped. No damage resulted from this test.

E. INCLINE-IMPACT TEST. Pallet no. 1 was the only sample tested. The inclined plane was set to allow the pallet to travel 8 feet prior to impacting a stationary wall. The pallet was rotated after each impact, until all four sides had been impacted. No damage to the pallet resulted from the impacts.

F. END OF TEST INSPECTION. Pallet no. 1 completed testing with only one post twisted. The damage to pallets nos. 2 and 3 was severe enough to discontinue testing following the repetitive shock test. Pallet no. 2 had the nails fastening the deck to one post of the other outside skid shear off. No additional damage was noted on pallet no. 3.

PALLET GROUP NO. 2

A. TEST OBSERVATIONS. A hydraulic nailer was used to install the nails in this group of pallets. The 3-1/4-inch nails were used to fasten the deck to the posts and the skids to the posts. The 1-5/8-inch nails were used to fasten the deck boards to the stringer boards. The 1-5/8-inch nails were not clinched over, as they did not extend beyond the surface of the boards. A 4,000-pound load of inert boxed ammunition was placed on each test sample. Banding the load on the pallet caused the deck board to crack along the strapping slots in the deck board.

B. STACKING TEST. Each test pallet was initially loaded to 15,000-pounds compression. The compression was released after one hour. None of the test samples were damaged.

C. REPETITIVE SHOCK TEST. The duration of the test was 90 minutes for each orientation of the pallet. The transportation simulator was operated for each pallet IAW Table 2 below. None of the samples were damaged as a result of vibration.

TABLE 2

<u>Pallet No.</u>	<u>Lateral Orientation (rpm)</u>	<u>Longitudinal Orientation (rpm)</u>
M1	148	145
M2	175	137
M3	157	144

D. EDGEWISE ROTATIONAL DROP TEST. Each side of the pallet was placed on a beam displacing it 4-1/2-inches above the floor. The opposite end of the pallet was raised to a height of 12 inches, then dropped. All three pallets were tested with no damage resulting.

E. INCLINE-IMPACT TEST. The inclined plane was set to allow the pallet to travel 8 feet prior to impacting a stationary wall. The pallet was rotated after each impact, until all four sides had been tested. All three pallets were tested with no damage resulting.

F. END OF TEST INSPECTION. All three pallets had cracks in the deck board that ran along the strapping slot. The cracks were caused by the tension of the banding. The cracks began at the end of the deck board and extended inward to the approximate location of the nails in the deck boards.

PALLET GROUP NO. 3

A. TEST OBSERVATIONS. A Stanley-Bostage pneumatic nailer was used to install the nails in this group of pallets. The 3-inch nails were used to attach the deck to the posts. The 2-1/4-inch nails fastened the skids to the posts. The 1-1/2-inch nails were used to fasten the deck boards to the stringer boards. The 1-1/2-inch nails were not clinched over, but no separation occurred between the deck and the stringer boards. A 4,000-pound load of inert boxed ammunition was placed on each test sample. A corner of one outside deck board of samples nos. 4 and 6 was cracked while placing the load on the pallet.

B. STACKING TEST. Each test pallet was initially loaded to 14,000-pounds compression. The compression was released after one hour. None of the test samples were damaged.

C. REPETITIVE SHOCK TEST. The duration of the test was 90 minutes for each orientation of the pallet. The transportation simulator was operated for each pallet IAW Table 3 below. The lateral orientation of vibration of pallet no. 4 was stopped after 50 minutes of vibration due to the nails fastening the skid to the post at one corner shearing off. The nails attaching the skid to the center post pulled out (see Part 6, page 6-4). A slight gap appeared to be present in sample no. 5 between the center post and the outside skid; however, the pallet completed the repetitive shock test intact. The center post of an outside skid of pallet no. 6 was twisted while the pallet was being removed from the transportation simulator.

TABLE 3

<u>Pallet No.</u>	<u>Lateral Orientation (rpm)</u>	<u>Longitudinal Orientation (rpm)</u>
4	170	142
5	175	160
6	170	165

D. EDGEWISE ROTATIONAL DROP TEST. Each side of the pallet was placed on a beam displacing it 4-1/2 inches above the floor. The opposite end of the pallet was raised to a height of 12 inches, then dropped. Pallet no. 4 was not tested due to damage that occurred during the repetitive shock test. Twice while raising pallet no. 5 for drops, the center block was pulled out of the pallet. In the first case, all 3 nails through the skid into the block sheared off while all the nails through the deck into the post were bent over. The block had 2 of the 3 nails through the skid into the block shear off while 2 of the 4 nails through the deck into the post bent over and 2 pulled through the deck and stringer boards (see Part 6, page 6-6). The drop test appeared to cause the steel strapping used to secure the load to cut into the deck board of pallet no. 6.

E. INCLINE-IMPACT TEST. The inclined plane was set to allow the pallet to travel 8 feet prior to impacting a stationary wall. The pallet was rotated after each impact, until all four sides had been tested. Pallet no. 6 was the only pallet tested. Pallet no. 5 was not tested due to damage inflicted during the drop test. No damage resulted.

F. END OF TEST INSPECTION. Samples nos. 4 and 5 had nails attaching the skid to the post shear off, causing portions of the pallet to become disassembled. Sample no. 6 completed testing with a slight separation between the deck and the post. The apparent cutting in of the strap in sample no. 6 was a result of the pallet being cracked prior to testing.

PALLET GROUP NO. 4

A. TEST OBSERVATIONS. A Stanley-Bostage pneumatic nailer was used to install the nails in this group of pallets. The 3-inch nails were used to attach the deck to the posts and the skids to the posts. The 1-1/2-inch nails were used to fasten the deck boards to the stringer boards. The 1-1/2-inch nails were not clinched over, but no separation occurred between the deck and the stringer boards. A 4,000-pound load of inert boxed ammunition was placed on each test sample.

B. STACKING TEST. Each test pallet was initially loaded to 15,000-pounds compression. The compression was released after one hour. None of the test samples were damaged.

C. REPETITIVE SHOCK TEST. The duration of the test was 90 minutes for each orientation of the pallet. The transportation simulator was operated for each pallet according to Table 4 below. While moving sample S1 after testing, the forklift tines struck the end of the deck boards and the side of the stringer board, causing each board to crack.

TABLE 4

<u>Pallet No.</u>	<u>Lateral Orientation (rpm)</u>	<u>Longitudinal Orientation (rpm)</u>
S1	145	123
S2	146	145
S3	140	143

D. EDGEWISE ROTATIONAL DROP TEST. Each side of the pallet was placed on a beam displacing it 4-1/2-inches above the floor. The opposite end of the pallet was raised to a height of 12-inches, then dropped. Each pallet was tested with no damage resulting.

E. INCLINE-IMPACT TEST. The inclined plane was set to allow the pallet to travel 8 feet prior to impacting a stationary wall. The pallet was rotated after each impact, until all four sides had been tested. Each sample was tested with no damage resulting.

F. END OF TEST INSPECTION. Other than the damage caused by the forklift tines to sample S1, no damage occurred to any of the pallets.

PALLET GROUP NO. 5

A. TEST OBSERVATIONS. A Stanley-Bostage pneumatic nailer was used to install the nails in this group of pallets. The 3-inch nails were used to attach the deck to the posts. An additional 2-1/4-inch nail, for a total of 4 nails, fastened the skids to the posts. The 1-1/2-inch nails were used to fasten the deck boards to the stringer boards. The 1-1/2-inch nails were not clinched over, but no separation occurred between the deck and the stringer boards. A 4,000-pound load of inert boxed ammunition was placed on each test sample. Minor cracking along the strapping slot in the deck boards of sample S6 existed.

B. STACKING TEST. Each test pallet was initially loaded to 15,000-pounds compression. The compression was released after one hour. Maneuvering of pallet S5 caused the center post of an outside skid to rotate. No damage occurred to samples S4 and S6.

C. REPETITIVE SHOCK TEST. The duration of the test was 90 minutes for each orientation of the pallet. The transportation simulator was operated for each pallet IAW Table 5 below. During the longitudinal vibration of pallet S4, a crack approximately 2 inches long appeared in the outside deck board near the location the strap crosses it. The center stringer board was marred by forklift tines while the pallet was being moved. No further damage resulted to samples S5 and S6.

TABLE 5

<u>Pallet No.</u>	<u>Lateral Orientation (rpm)</u>	<u>Longitudinal Orientation (rpm)</u>
S4	145	170
S5	145	165
S6	150	140

D. EDGEWISE ROTATIONAL DROP TEST. Each side of the pallet was placed on a beam displacing it 4-1/2 inches above the floor. The opposite end of the pallet was raised to a height of 12 inches, then dropped. While raising pallet S5 for the final drop, the previously rotated block pulled away from the pallet, as one of the nails through the skid sheared off while the other 3 bent over and the 3 nails through the deck into the post bent over (see Part 6, page 6-8). No further damage resulted to the other test samples.

E. INCLINE-IMPACT TEST. The inclined plane was set to allow the pallet to travel 8 feet prior to impacting a stationary wall. The pallet was rotated after each impact, until all four sides had been tested. Pallet S5 was not tested. No damage occurred to pallet S4. One wing of pallet S6 was broken while the pallet was being maneuvered for impacts.

F. END OF TEST INSPECTION. Sample S5 had only one nail shear off and the rest of the nails pulled out. The rest of the posts in this pallet, as well as the other samples, remained secure. Sample S4 had cracks along the strapping slot in deck boards extending inward 2-1/2-inches.

PART 6

PHOTOGRAPHS

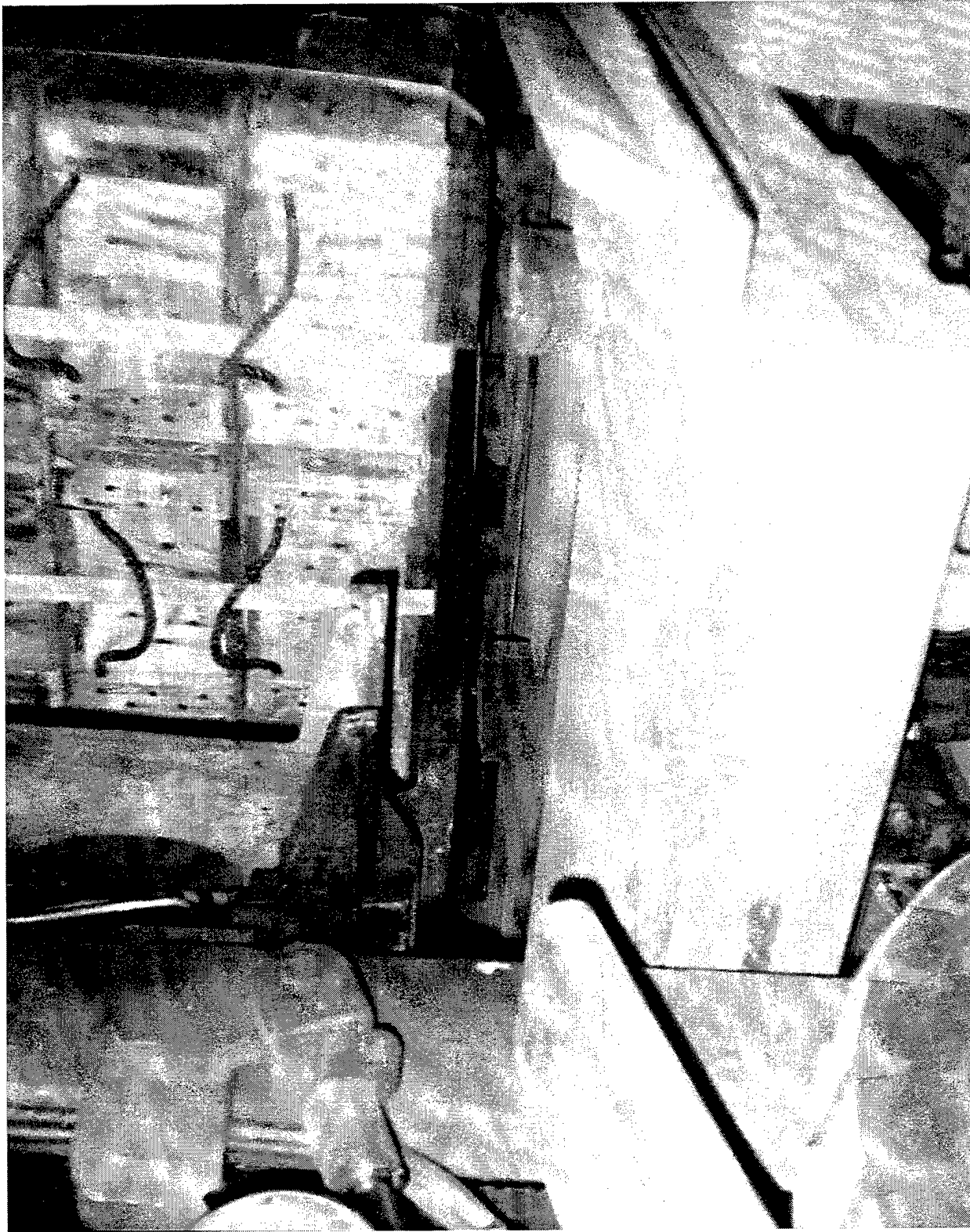

U.S. ARMY DEFENSE AMMUNITION CENTER AND SCHOOL -
SAVANNA, IL

USADACS-DEV-96-13-01. This photo shows Madison County Wood Products, Inc. pallet no. 2 on the vibration table. The front skid came loose from the deck.



	U.S. ARMY DEFENSE AMMUNITION CENTER AND SCHOOL - SAVANNA, IL	
AO317-SCN96-37-834. This photo shows the nails attaching the deck to the post sheared off causing one corner of Madison County Wood Products, Inc. pallet no. 3 to become loose.		



U.S. ARMY DEFENSE AMMUNITION CENTER AND SCHOOL -
SAVANNA, IL

AO317-SCN96-37-836. This photo shows the detached outside skid of Stewart's Forest Products, Inc. pallet
no. 4.



	U.S. ARMY DEFENSE AMMUNITION CENTER AND SCHOOL - SAVANNA, IL	
AO317-SCN96-37-837. This photo shows the sheared off nails that attached the skid to the post of Stewart's Forest Products, Inc. pallet no. 4.		

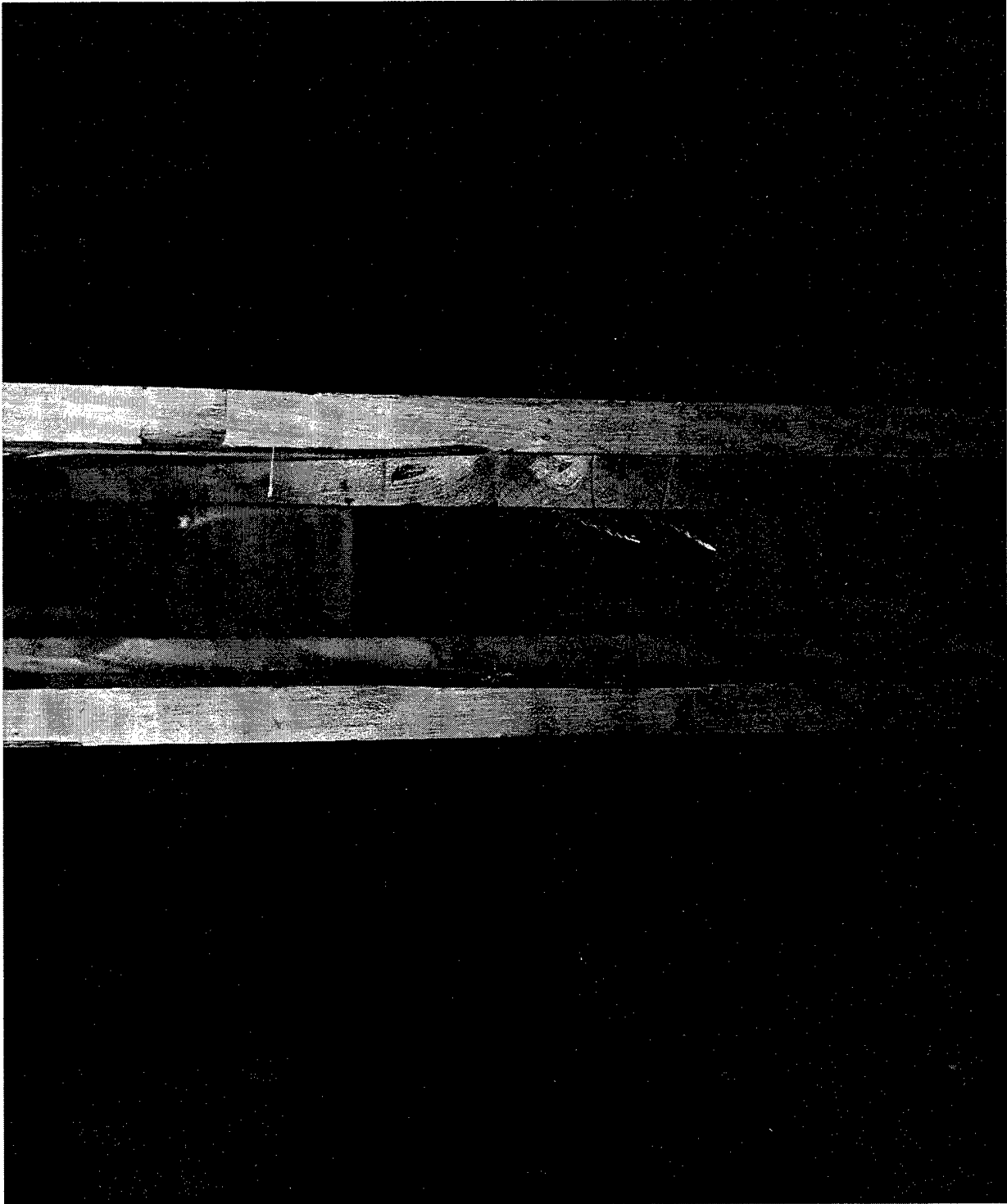

	U.S. ARMY DEFENSE AMMUNITION CENTER AND SCHOOL - SAVANNA, IL	
--	---	--

AO317-SCN96-37-838. This photo shows the location where one of the posts of Stewart's Forest Products, Inc. pallet no. 5 pulled away from during the edgewise rotational drop test.



	U.S. ARMY DEFENSE AMMUNITION CENTER AND SCHOOL - SAVANNA, IL	
AO317-SCN96-37-830. This photo shows the top of the block that pulled away from Stewart's Forest Products, Inc. pallet no. 5. Note the 2 nails present that pulled through the stringer board and deck.		

PART 7

DRAWINGS

42 Inch X 53 Inch Pallet
Nails are those used by
Madison County Wood Products, Inc.

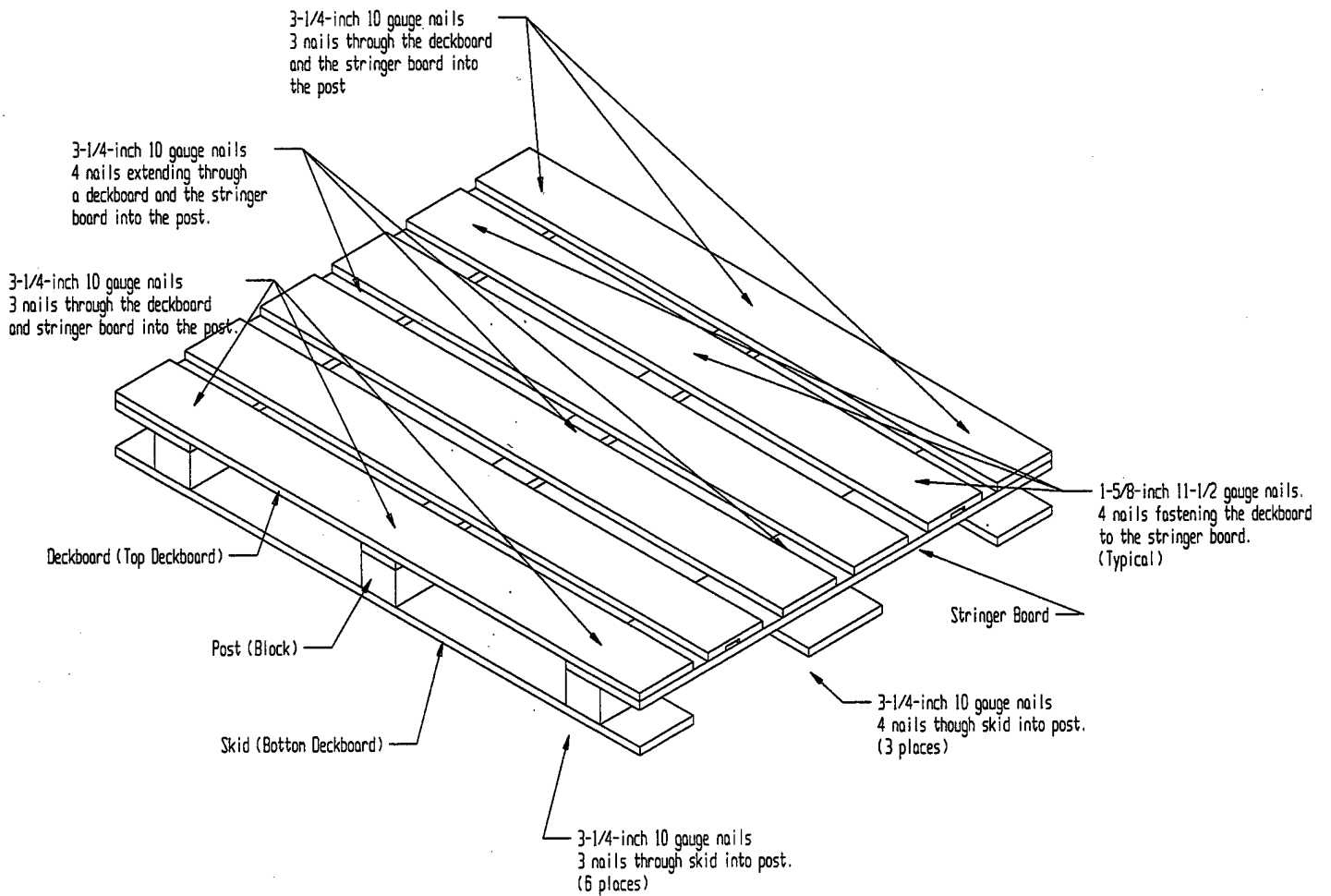

42 Inch X 53 Inch Pallet
Nails are those used by
Stewart's Forest Products, Inc.

