

JUNE 1996

REPORT NO. 96-22

WOODEN PALLET FOR
PA116 CONTAINERS
MIL-STD-1660 TESTS

19961104 113

Prepared for:
U.S. Army Armament Research, Development
and Engineering Center
ATTN: AMSTA-AR-ESK
Rock Island, IL 61299-7300

Distribution Unlimited



VALIDATION ENGINEERING DIVISION
SAVANNA, ILLINOIS 61074-9639

DISCLAIMER NOTICE

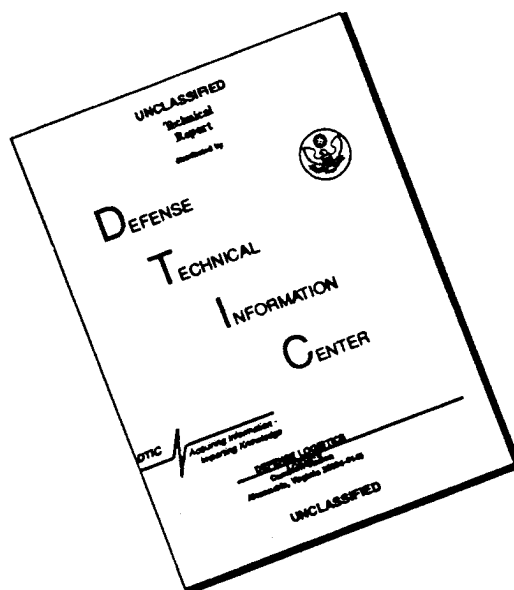

THIS DOCUMENT IS BEST QUALITY AVAILABLE. THE COPY FURNISHED TO DTIC CONTAINED A SIGNIFICANT NUMBER OF PAGES WHICH DO NOT REPRODUCE LEGIBLY.

AVAILABILITY NOTICE

A copy of this report will be furnished each attendee on automatic distribution. Additional copies or authority for reprinting may be obtained by written request from Director, U.S. Army Defense Ammunition Center and School, ATTN: SIOAC-DEV, Savanna, IL 61074-9639.

DISTRIBUTION INSTRUCTIONS

Destroy this report when no longer needed. Do not return.

Citation of trade names in this report does not constitute an official endorsement.

The information contained herein will not be used for advertising purposes.

REPORT DOCUMENTATION PAGE				Form Approved OMB No. 0704-0188	
1a. REPORT SECURITY CLASSIFICATION UNCLASSIFIED		1b. RESTRICTIVE MARKINGS			
2a. SECURITY CLASSIFICATION AUTHORITY		3. DISTRIBUTION / AVAILABILITY OF REPORT UNLIMITED			
2b. DECLASSIFICATION / DOWNGRADING SCHEDULE					
4. PERFORMING ORGANIZATION REPORT NUMBER(S) 96-22		5. MONITORING ORGANIZATION REPORT NUMBER(S)			
6a. NAME OF PERFORMING ORGANIZATION U.S. Army Defense Ammunition Center and School		6b. OFFICE SYMBOL (if applicable) SIOAC-DEV	7a. NAME OF MONITORING ORGANIZATION		
6c. ADDRESS (City, State, and ZIP Code) ATTN: SIOAC-DEV Savanna, IL 61074-9639		7b. ADDRESS (City, State, and ZIP Code)			
8a. NAME OF FUNDING / SPONSORING ORGANIZATION U.S. Army Armament Research, Development and Engineering Center		8b. OFFICE SYMBOL (if applicable) AMSTA-AR-ESK	9. PROCUREMENT INSTRUMENT IDENTIFICATION NUMBER		
8c. ADDRESS (City, State, and ZIP Code) ATTN: AMSTA-AR-ESK Rock Island, IL 61299-7300		10. SOURCE OF FUNDING NUMBERS			
		PROGRAM ELEMENT NO.	PROJECT NO.	TASK NO.	WORK UNIT ACCESSION NO.
11. TITLE (Include Security Classification) Wooden Pallet for PA116 Containers MIL-STD-1660 Tests					
12. PERSONAL AUTHOR(S) Bradley J. Haas					
13a. TYPE OF REPORT Final		13b. TIME COVERED FROM _____ TO _____		14. DATE OF REPORT (Year, Month, Day) 1996 June	15. PAGE COUNT
16. SUPPLEMENTARY NOTATION					
17. COSATI CODES			18. SUBJECT TERMS (Continue on reverse if necessary and identify by block number)		
FIELD	GROUP	SUB-GROUP			
19. ABSTRACT (Continue on reverse if necessary and identify by block number)					
<p>The U.S. Army Defense Ammunition Center and School (USADACS), Validation Engineering Division (SIOAC-DEV), was tasked by the U.S. Army Armament Research, Development and Engineering Center (ARDEC) to conduct MIL-STD-1660 tests on wooden pallets used for PA116 containers. The pallets were provided by Olin Ordnance and Alliant Techsystems, Inc. This report contains test results with the initial pallets tested from each supplier failing to meet MIL-STD-1660, Design Criteria for Ammunition Unit Loads, requirements. Additional pallets were modified, correcting the nail failures that occurred previously.</p>					
20. DISTRIBUTION / AVAILABILITY OF ABSTRACT <input checked="" type="checkbox"/> UNCLASSIFIED/UNLIMITED <input type="checkbox"/> SAME AS RPT. <input type="checkbox"/> DTIC USERS			21. ABSTRACT SECURITY CLASSIFICATION UNCLASSIFIED		
22a. NAME OF RESPONSIBLE INDIVIDUAL JEROME H. KROHN		22b. TELEPHONE (Include Area Code) 815-273-8929		22c. OFFICE SYMBOL SIOAC-DEV	

U.S. ARMY DEFENSE AMMUNITION CENTER AND SCHOOL
VALIDATION ENGINEERING DIVISION
SAVANNA, IL 61074-9639

REPORT NO. 96-22

WOODEN PALLET FOR PA116 CONTAINERS MIL-STD-1660 TESTS

TABLE OF CONTENTS

PART	PAGE NO.
1. INTRODUCTION	1-1
A. BACKGROUND	1-1
B. AUTHORITY	1-1
C. OBJECTIVE	1-1
D. CONCLUSION	1-1
E. RECOMMENDATIONS	1-1
2. ATTENDEES	2-1
3. TEST PROCEDURES	3-1
4. TEST EQUIPMENT	4-1
5. PALLET NAILS	5-1
6. TEST RESULTS	6-1
7. PHOTOGRAPHS	7-1
8. DRAWING	8-1

PART 1

INTRODUCTION

A. BACKGROUND. The U.S. Army Defense Ammunition Center and School (USADACS), Validation Engineering Division (SIOAC-DEV), was tasked by the U.S. Army Armament Research, Development and Engineering Center (ARDEC) to conduct MIL-STD-1660 tests on wooden pallets for PA116 containers.

B. AUTHORITY. This test was conducted IAW mission responsibilities delegated by the U.S. Army Armament, Munitions and Chemical Command (AMCCOM), Rock Island, IL.

C. OBJECTIVE. The objective of these tests is to ascertain that the nails used in the construction of these pallets are capable of meeting MIL-STD-1660, Design Criteria for Ammunition Unit Loads, requirements.

D. CONCLUSION. With specified modifications to the samples, the nails used in the construction of the pallets of Olin Ordnance and Alliant Techsystems, Inc. do not fail when the palletized unit load is subjected to MIL-STD-1660 requirements. In each case, the specified modification was the installation of additional nails in the pallet.

E. RECOMMENDATIONS:

(1) Prior to stacking unitized loads, each pallet should be inspected to ensure all skids make contact with the floor. In the event the pallet skids do not contact the floor, shims should be used to create a stable stack.

(2) The nails used to fasten the deck dunnage plywood to the deck should be driven to a depth allowing the head of the nail to be flush with the plywood.

PART 2

26 MARCH - 9 MAY 1996

ATTENDEES

Bradley J. Haas
Mechanical Engineer
DSN 585-8336
815-273-8336

Director
U.S. Army Defense Ammunition Center
and School
ATTN: SIOAC-DEV
Savanna, IL 61074-9639

26 - 29 MARCH 1996

Paul D. Blankenship
319-753-7946

Olin Ordnance
10101 9th Street North
St. Petersburg, FL 33716

27 MARCH 1996

Mark Rehmstedt
DSN 793-8206

Commander
U.S. Army Armament Research, Development
and Engineering Center
ATTN: AMSTA-AR-ESK
Rock Island, IL 61299-7300

PART 3

TEST PROCEDURES

The test procedures outlined in this section were extracted from MIL-STD-1660, Design Criteria for Ammunition Unit Loads, 8 April 1977. This standard identifies nine steps that a unitized load must undergo if it is to be considered acceptable. The five tests that were conducted on the test pallets are summarized below.

A. STACKING TESTS. The unit load was loaded to simulate a stack of identical unit loads stacked 16 feet high, for a period of one hour. This stacking load was simulated by subjecting the unit load to a compression weight equal to an equivalent 16-foot stacking height. The compression load was calculated in the following manner. The unit load weight was divided by the unit load height in inches and multiplied by 192. The resulting number was the equivalent compressive force of a 16-foot-high load.

B. REPETITIVE SHOCK TEST. The repetitive shock test was conducted IAW Method 5019, Federal Standard 101. The test procedure is as follows: The test specimen was placed on, but not fastened to, the platform. With the specimen in one position, the platform was vibrated at 1/2-inch amplitude (1-inch double amplitude) starting at a frequency of approximately 3 cycles per second. The frequency was steadily increased until the package left the platform. The resonant frequency was achieved when a 1/16-inch-thick feeler gage momentarily slid freely between every point on the specimen in contact with the platform at some instance during the cycle or a platform acceleration achieved 1 ± 0.1 Gs. Midway into the testing period, the specimen was rotated 90 degrees and the test continued for the duration. Unless failure occurred, the total time of vibration was two hours if the specimen was tested in one position and three hours for more than one position.

C. EDGEWISE ROTATIONAL DROP TEST. This test was conducted using the procedures of Method 5008, Federal Standard 101. The procedure for the edgewise rotational drop test is as follows: The specimen was placed on its skids with one end of the pallet supported on a beam 4-1/2 inches high. The height of the beam was increased if necessary to ensure that there was no support for the skids between the ends of the pallet when dropping took place, but was not high enough to cause the pallet to slide on the supports when the dropped end was raised for the drops. The unsupported end of the pallet was then raised and allowed to fall freely to the concrete, pavement, or similar underlying surface from a prescribed height. Unless otherwise specified, the height of drop for level A protection conforms to the following tabulation:

GROSS WEIGHT (WITHIN RANGE LIMITS) (Pounds)	DIMENSIONS OF ANY EDGE, HEIGHT OR WIDTH (WITHIN RANGE LIMITS) (Inches)	HEIGHT OF DROPS ON EDGES	
		Level A	Level B
		(Inches)	(Inches)
150 - 250	60 - 66	36	27
250 - 400	66 - 72	32	24
400 - 600	72 - 80	28	21
600 - 1000	80 - 95	24	18
1000 - 1500	95 - 114	20	16
1500 - 2000	114 - 144	17	14
2000 - 3000	Above 145 - No limit	15	12
Above - 3000		12	9

D. INCLINE-IMPACT TEST. This test was conducted by using the procedure of Method 5023, Incline-Impact Test of Federal Standard 101. The procedure for the Incline-Impact Test is as follows: The specimen was placed on the carriage with the surface or edge which is to be impacted projecting at least 2 inches beyond the front end of the carriage. The carriage was brought to a predetermined position on the incline and released. If it is desired to concentrate the impact on any particular position on the container, a 4- by 4-inch timber was attached to the bumper in the desired position before the test. No part of the timber was struck by the carriage. The position of the container on the carriage and the sequence in which surfaces and edges are subjected to impacts was at the option of the testing activity and depends upon the objective of the tests. This test is to determine satisfactory requirements for a container or pack, and, unless otherwise specified, the specimen was subjected to one impact on each surface that has each dimension less than 9.5 feet. Unless otherwise specified, the velocity at time of impact was 7 feet per second.

E. SLING COMPATIBILITY TEST. Unit loads utilizing special design of non-standard pallets were lifted, swung, lowered and otherwise handled as necessary, using slings of the types normally used for handling the unit loads under consideration. Slings were easily attached and removed. Danger of slippage or disengagement when the load is suspended was cause for the rejection of the unit load.

PART 4

TEST EQUIPMENT

A. Pallet Produced at MCAAP (Test Group No. 1).

1. Pallet Width: 40 inches
2. Pallet Length: 44 inches
3. Weight Loaded: 2,600 pounds
4. Quantity (PA116 Container): 30 containers

B. MCAAP Pallet Modified by Olin Ordnance (Test Group No. 2).

1. Pallet Width: 40 inches
2. Pallet Length: 44 inches
3. Weight Loaded: 2,600 pounds
4. Quantity (PA116 Container): 30 containers

C. Modified Pallet Supplied by Alliant Techsystems, Inc. (Test Group No. 3).

1. Pallet Width: 40 inches
2. Pallet Length: 44 inches
3. Weight Loaded: 2,625 pounds
4. Quantity (PA116 Container): 30 containers

D. Modified Pallet Supplied by Alliant Techsystems, Inc. (Test Group No. 4).

1. Pallet Width: 40 inches
2. Pallet Length: 44 inches
3. Weight Loaded: 2,625 pounds
4. Quantity (PA116 Container): 30 containers

E. Compression Tester.

1. Manufacturer: Ormond Manufacturing
2. Platform: 60- by 60-inches
3. Compression Limit: 50,000 pounds
4. Tension Limit: 50,000 pounds

F. Transportation Simulator.

- | | |
|------------------|--------------------|
| 1. Manufacturer: | Gaynes Laboratory |
| 2. Capacity: | 6,000-pound pallet |
| 3. Displacement: | 1/2-inch amplitude |
| 4. Speed: | 50 to 400 rpm |
| 5. Platform: | 5- by 8-foot |

G. Incline-Impact Plane.

- | | |
|------------------|--------------------|
| 1. Manufacturer: | Conbur Incline |
| 2. Type: | Impact Tester |
| 3. Grade: | 10 percent incline |
| 4. Length: | 12-foot |

PART 5

PALLET NAILS

- A. Length: 3-1/4 inches
Thickness: 10 gauge (0.135 inch)
Supplier: Insteel Wire Products
Nail Type: Pallet nail
Description: B/D Y40701 R1
- B. Length: 2-1/4 inches
Thickness: 11 gauge (0.1205 inch)
Supplier: Stiff Stock
Nail Type: Drive screw pallet nail
- C. Length: 1-5/8 inches
Thickness: 11 gauge (0.1205 inch)
Supplier: Stiff Stock
Nail Type: Drive screw pallet nail
Description: 89176 Bright
- D. Length: 2-1/4 inches
Thickness: 0.120 inches
Head Diameter: 0.280 inches
Shank Type: Screw
Point Type: Diamond
Material: Steel-Hardened
Finish: Standard
Manufacturer: Duo-Fast
Stock Number: 503H
Quantity: 18 nails per pallet

Pallet Produced at MCAAP.

Nails of type A, as described on page 5-1, were driven from the deck board through the stringer board and into the post. A total of 4 nails were employed through deck boards into the posts of the outside skids while 4 nails were employed for the posts of the center skid.

Nails of type B, as described on page 5-1, fastened the skid to the posts. A total of 4 nails were used to fasten the outside skids to each of the 3 posts to which it is fastened. A total of 6 nails were used to fasten the center skid to each post.

Nails of type C, as described on page 5-1, were used to fasten the deck boards to the stringer boards at the locations where no post is under the stringer board. Four nails were utilized at each of these junctions. These nails were also used to fasten the deck dunnage plywood to the deck boards. Six nails were used to fasten each deck dunnage plywood sheet.

MCAAP Pallet Modified by Olin Ordnance.

These pallets were produced at MCAAP employing the same nailing pattern as described above. Olin Ordnance added two additional nails fastening the skid to each post. The additional nails are described in D on page 5-1.

Modified Pallet Supplied by Alliant Techsystems, Inc.

Two additional nails from group D, page 5-1, were inserted through the bottom deck boards into each post.

Modified Pallet Supplied by Alliant Techsystems, Inc.

The pallet was nailed the same as the group above with 6 additional 6d common nails used to fasten each deck dunnage plywood to the pallet deck. A nail was placed in each corner of the deck dunnage plywood. An additional nail was placed midway between the corner nails along

the long side of the plywood. For the 18-3/4-inch-wide deck dunnage plywood, one nail was inserted through the deck into each of the 6 posts. The 17-3/4-inch deck dunnage plywood had 3 of the 6 nails through the deck into the post with the remaining 3 nails clinched over below the deck.

PART 6

TEST RESULTS

TEST GROUP NO. 1

TEST OBSERVATIONS. Two samples were tested from this group. The nails fastening the deck dunnage plywood to the deck boards were driven so the head of each nail was below the surface of the plywood. This was the case for each sample.

A. STACKING TEST. Each unitized pallet load was initially loaded to 10,000 pounds compression. The compression was released after 1 hour. No damage was noted to either sample during this test.

B. REPETITIVE SHOCK TEST. The duration of the test was 90 minutes for each orientation of each pallet. For the first sample in the lateral orientation, the transportation simulator was set to 220 rpm. No damage was noted. The unitized pallet load was then vibrated at 150 rpm in the longitudinal direction. After 50 minutes of vibration, the center skid was no longer fastened to any post. All the nails fastening the skid to the posts had sheared off. The second unitized pallet load was placed on the transportation simulator in the longitudinal orientation. The transportation simulator was operated at 145 rpm. After 90 minutes, the center skid was only fastened to one of the outside posts. All the nails fastening the skid to the other two posts had sheared off.

C. END OF TEST INSPECTION. The first sample had 3 nails pull through the one sheet of deck dunnage plywood and had 1 nail pull through the other sheet of plywood.

TEST GROUP NO. 2

TEST OBSERVATIONS. Three samples were tested from this group. The nails fastening the deck dunnage plywood to the deck boards were driven so the head of each nail was below the surface of the plywood. This was the case for each sample. The third sample had 1 nail pull through the plywood prior to testing.

A. STACKING TEST. Each unitized pallet load was initially loaded to 10,000 pounds compression. The compression was released after 1 hour. No damage was noted to any of the samples during this test.

B. REPETITIVE SHOCK TEST. The duration of the test was 90 minutes for each orientation of each unitized pallet load. Table 1 contains the frequency each sample was vibrated at.

TABLE 1

<u>SAMPLE</u>	<u>LONGITUDINAL</u> (rpm)	<u>LATERAL</u> (rpm)
1	125	150
2	140	145
3	125	130

All three samples completed the repetitive shock test with no damage occurring. The top of the center skid of samples 1 and 2 were warm upon completion of the longitudinal orientation of vibration. However, these skids were still firmly fastened to the posts with no evidence of the nails shearing.

C. EDGEWISE-ROTATIONAL DROP TEST. Each side of sample 1 was placed on a beam displacing it 4-1/2 inches while the opposite end was raised to a height of 18 inches and then dropped. No structural damage resulted. However, following the second lateral drop, when 2 of the 3 skids were in contact with the floor, the third skid was 2 inches off the floor. Sample 2 was also dropped from 18 inches with the opposite end of the pallet on a 4-1/2-inch beam. The first lateral drop of the second sample resulted in a broken stringer board. The break ran along the grain of the wood, which is oriented across the width of the board in this stringer board. The broken stringer board caused the top row of canisters to become unnested. All 4 sides of the third sample were dropped from 18 inches with the opposite end of the pallet on a 4-1/2-inch beam. Following the second lateral drop, a gap of 3-1/2 inches existed between the raised skid and the floor. This gap was reduced to 1/2-inch following the second longitudinal drop.

D. INCLINE-IMPACT TEST. The inclined plane was set to allow the pallet to travel 8 feet prior to impacting a stationary wall. The pallet was rotated after each impact, until all four sides had been tested. Samples nos. 1 and 3 were impacted with no damage resulting.

E. SLING COMPATIBILITY TEST. Sample 1 completed testing with 1 wing of 1 skid breaking off while the unitized pallet load was being placed on the floor following a lift. Sample no. 3 had 2 wings of skids break while the unitized pallet load was being placed on the floor following lifts.

F. END OF TEST INSPECTION. In sample no. 1, 3 of the 12 nails attaching plywood to the deck boards pulled through the plywood.

TEST GROUP NO. 3

TEST OBSERVATIONS. Three samples were tested from this group. The center skid of these pallets consisted of 2 boards. One of the additional nails was placed into each of these boards.

A. STACKING TEST. Each unitized pallet load was initially loaded to 11,000 pounds compression. The compression was released after one hour. No damage was noted to any of the samples during this test.

B. REPETITIVE SHOCK TEST. The duration of the test was 90 minutes for each orientation of the unitized pallet load. Table 2 contains the frequency each sample was vibrated at.

TABLE 2

<u>SAMPLE</u>	<u>LONGITUDINAL</u> <u>(rpm)</u>	<u>LATERAL</u> <u>(rpm)</u>
1	140	175
2	130	190
3	130	135

All three samples completed the repetitive shock test with the unit load remaining intact. Only two of the three skids of sample no. 2 remained in contact with the floor following the lateral vibration. A 3/4-inch gap existed between the floor and the third skid.

C. EDGEWISE-ROTATIONAL DROP TEST. Each side of sample no. 1 was placed on a beam displacing it 4-1/2 inches while the opposite end was raised to a height of 18 inches and then dropped. No structural damage resulted. However, following the final drop, when 2 of the 3 skids were in contact with the floor, the third skid was 1-3/4 inches off the floor. Sample no. 2

was also dropped from 18 inches with the opposite end of the pallet on a 4-1/2-inch beam. The first lateral drop of the second sample resulted in the top row of canisters becoming unnested. As the unit load was raised for the final drop, the top row of canisters was no longer prevented from sliding. The cause of this failure is believed to be damaged canisters used in the assembly of the load not creating the proper nesting surface. All 4 sides of the third sample were dropped from 18 inches with the opposite end of the pallet on a 4-1/2-inch beam. Following the first lateral drop, a 3-1/2-inch gap existed between the raised skid and the floor. This gap was 3 inches following the second lateral drop. After the final drop, a 1/2-inch gap existed.

D. INCLINE-IMPACT TEST. The inclined plane was set to allow the pallet to travel 8 feet prior to impacting a stationary wall. The pallet was rotated after each impact, until all four sides had been tested. Samples nos. 1 and 3 were impacted with no damage resulting.

E. SLING COMPATIBILITY TEST. Only samples nos. 1 and 3 were tested. The top adapter of sample 1 slid approximately 3-3/4 inches when raised by 1 lifting ring. The unit load was lowered with all the containers in place. The top adapter slid as a result of the bands becoming loose, due to a 3/4-inch gap under the third skid. The unit load of sample no. 3 remained intact throughout the sling compatibility test. A 5/8-inch gap existed between the floor and the third skid upon completion of testing.

F. END OF TEST INSPECTION. In sample no. 1, 5 of the 6 nails fastening each deck dunnage plywood to the deck boards sheared off. The 17-3/4-inch-wide deck dunnage plywood piece of sample no. 3 was completely free as 3 nails sheared off and 3 nails pulled through the plywood. The 18-3/4-inch-wide deck dunnage plywood also had 1 nail shear off.

TEST GROUP NO. 4

TEST OBSERVATIONS. One sample was tested from this group. This test sample is pallet no. 3 from group no. 3 with 12 additional 6d common nails used to fasten the deck dunnage plywood to the deck.

A. **STACKING TEST.** The unitized pallet load was initially loaded to 11,000 pounds compression. The compression was released after 1 hour. No damage was noted to the sample during this test.

B. **REPETITIVE SHOCK TEST.** The duration of the test was 90 minutes for each orientation of the unitized pallet load. The lateral orientation was performed at 130 rpm with no damage resulting. The longitudinal orientation was performed at 135 rpm with no damage resulting.

C. **EDGEWISE-ROTATIONAL DROP TEST.** Each side of the sample was placed on a beam displacing it 4-1/2 inches while the opposite end was raised to a height of 18 inches and then dropped. No damage resulted.

D. **INCLINE-IMPACT TEST.** The inclined plane was set to allow the pallet to travel 8 feet prior to impacting a stationary wall. The pallet was rotated after each impact, until all four sides had been tested. No damage resulted.

E. **SLING COMPATIBILITY TEST.** No damage resulted to the test sample during this test.

F. **END OF TEST INSPECTION.** The deck dunnage plywood remained in place with no damage to the nails fastening the deck dunnage plywood to the deck occurring.

PART 7

PHOTOGRAPHS

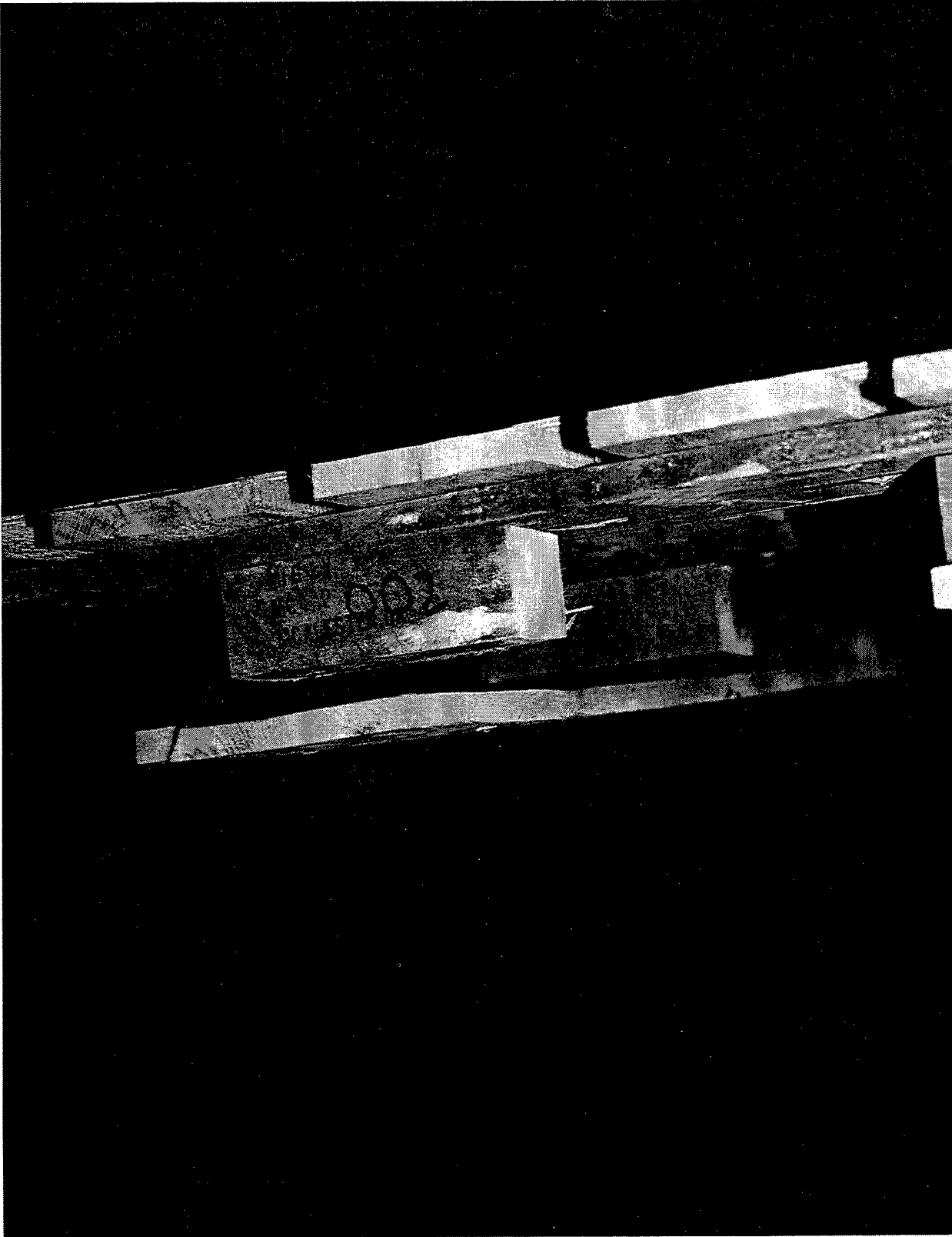

	U.S. ARMY DEFENSE AMMUNITION CENTER AND SCHOOL - SAVANNA, IL	
--	---	--

AO317-SCN96-140-2699. This photo shows a loose skid that was a result of nails shearing off during testing.



	U.S. ARMY DEFENSE AMMUNITION CENTER AND SCHOOL - SAVANNA, IL	
AO317-SCN96-140-2701. This photo shows the nails fastening a skid to the post of a reworked pallet. Note the additional number of nails used.		



U.S. ARMY DEFENSE AMMUNITION CENTER AND SCHOOL -
SAVANNA, IL

AO317-SCN96-140-2700. This photo shows a crack in the stringer board which occurred during the drop test.
This pallet is from test group no. 2.

PART 8

DRAWING

APPENDIX 7B

UNITIZATION PROCEDURES FOR COMPLETE ROUNDS PACKED IN CYLINDRICAL METAL CONTAINERS ON 4-WAY ENTRY PALLETS*

PA116 SERIES CONTAINER

INDEX

<u>ITEM</u>	<u>PAGE(S)</u>
PALLET UNIT DATA - - - - -	2
GENERAL NOTES - - - - -	3
UNIT DETAIL - - - - -	4
DUNNAGE DETAILS - - - - -	5
FILLERS AND INSTALLATION PROCEDURES FOR OMITTED CONTAINERS- - - - -	6,7
BLANK PAGE - - - - -	8

NOTICE: THIS APPENDIX CANNOT STAND ALONE BUT MUST BE USED IN CONJUNCTION WITH
THE BASIC UNITIZATION PROCEDURES DRAWING 19-48-4079-20PM1002.

* SEE GENERAL NOTE "L" ON PAGE 3.

DISTRIBUTION STATEMENT A.
APPROVED FOR PUBLIC RELEASE;
DISTRIBUTION IS UNLIMITED.

U.S. ARMY MATERIEL COMMAND DRAWING					
APPROVED, U.S. ARMY ARMAMENT, MUNITIONS AND CHEMICAL COMMAND AMSTA-ARA-ESK AMSMC-TMJ	DRAFTSMAN		INGEBORG DEPPE		
	ENGINEER		SANDRA M. SCHULTZ		
	SUPPLY ENGINEERING DIVISION	TRANSPORTATION ENGINEERING DIVISION	VALIDATION ENGINEERING DIVISION		
APPROVED BY ORDER OF COMMANDING GENERAL, U.S. ARMY MATERIEL COMMAND		LOGISTICS ENGINEERING OFFICE			
NOVEMBER 1987					
U.S. ARMY DEFENSE AMMUNITION CENTER AND SCHOOL		CLASS	DIVISION	DRAWING	FILE
REVISION NO. 3	NOVEMBER 1994	19	48	4079/ 7B	20PM 1002
SEE THE REVISION LISTING ON PAGE 2					

DO NOT SCALE

PALLET UNIT DATA				
ITEMS INCLUDED		HAZARD CLASS AND DIVISION		APPROX WEIGHT LBS
NSN	OODIC	OD CLASS	COMP GROUP	
1315				
01-250-8636	C784	(08)1.2	C	2,412
01-369-6612	C784	(08)1.2	C	2,412
01-242-4796	C785	(08)1.2	C	2,082
01-288-5545	C785	(08)1.2	C	2,082

HAZARD CLASSIFICATION DATA CONTAINED IN THE ABOVE CHART IS FOR GUIDANCE AND INFORMATIONAL PURPOSES ONLY. VERIFICATION OF THE SPECIFIED DATA SHOULD BE MADE BY CONSULTING THE MOST RECENT JOINT HAZARD CLASSIFICATION SYSTEM LISTING OR OTHER APPROVED LISTING(S).

REVISIONS

REVISION NO. 1, DATED MARCH 1989,
CONSISTS OF:

1. CHANGING THE OD CLASSES IN THE "PALLET UNIT DATA" CHART.
2. ADDING GENERAL NOTE "N".
3. ADDING ITEM BY NATIONAL STOCK NUMBER TO "PALLET UNIT DATA" CHART.

REVISION NO. 2, DATED MAY 1994,
CONSISTS OF:

1. CHANGING DRAWING IN ACCORDANCE WITH ECP M3K3014.

REVISION NO. 3, DATED NOVEMBER 1994,
CONSISTS OF:

1. CHANGING DRAWING IN ACCORDANCE WITH ECP M4T3006 AND ECP M3T4321.

GENERAL NOTES

- A. THIS APPENDIX CANNOT STAND ALONE BUT MUST BE USED IN CONJUNCTION WITH THE BASIC UNITIZATION PROCEDURES DRAWING 19-48-4079-20PM1002. TO PRODUCE AN APPROVED UNIT LOAD, ALL PERTINENT PROCEDURES, SPECIFICATIONS AND CRITERIA SET FORTH WITHIN THE BASIC DRAWING WILL APPLY TO THE PROCEDURES DELINEATED IN THIS APPENDIX. ANY EXCEPTIONS TO THE BASIC PROCEDURES ARE SPECIFIED IN THIS APPENDIX.
- B. DIMENSIONS, CUBE AND WEIGHT OF A PALLET UNIT WILL VARY SLIGHTLY DEPENDING UPON THE ACTUAL DIMENSIONS OF THE CONTAINER AND THE WEIGHT OF THE SPECIFIC ITEM BEING UNITIZED.
- C. FOR OUTLOADING OF THE ITEMS COVERED BY THIS APPENDIX CONTACT THE U.S. ARMY DEFENSE AMMUNITION CENTER AND SCHOOL, ATTN: SMCAC-DET, SAVANNA, IL 61074-9639. FOR STORAGE OF THE ITEMS COVERED BY THIS APPENDIX, CONTACT THE U.S. ARMY DEFENSE AMMUNITION CENTER AND SCHOOL, ATTN: SMCAC-DES, SAVANNA, IL 61074-9639 FOR SPECIFIC PROCEDURAL GUIDANCE.
- D. FOR METHOD OF SECURING A STRAP CUTTER TO THE PALLET UNIT, SEE AMC DRAWING 19-48-4127-20P1000.
- E. IF ITEMS COVERED HEREIN ARE UNITIZED PRIOR TO ISSUANCE OF THIS APPENDIX, THE CONTAINERS NEED NOT BE REUNITIZED SOLELY TO CONFORM TO THIS APPENDIX.
- F. FOR DETAILS OF THE PA116 SERIES CONTAINER, SEE U.S. ARMY ARMAMENT RESEARCH AND DEVELOPMENT CENTER DRAWING NO. 9366831.
- CONTAINER DIMENSIONS - - - 44-1/2" LONG X 7-3/4" WIDE
X 7-3/4" HIGH
CONTAINER CUBE - - - - - 1.5 CUBIC FEET (APPROX)
CONTAINER WEIGHT
(WITH ROUND) - - - - - 64 OR 75 POUNDS (APPROX)
(EMPTY) - - - - - 23 POUNDS (APPROX)
- G. THE UNITIZATION PROCEDURES DEPICTED HEREIN MAY ALSO BE USED FOR UNITIZING COMPLETE ROUNDS WHEN IDENTIFIED BY DIFFERENT NATIONAL STOCK NUMBERS (NSN) THAN THOSE SHOWN ON PAGE 2, PROVIDED THE ITEM IS PACKED IN THE SAME CONTAINER. THE EXPLOSIVE CLASSIFICATION OF OTHER ITEMS MAY BE DIFFERENT THAN WHAT IS SHOWN.
- H. FOR DETAILS OF THE METAL LIFTING FRAME SEE U.S. ARMY DEFENSE AMMUNITION CENTER AND SCHOOL DRAWING AC200000807 AND MILITARY SPECIFICATION MIL-A-70788.
- J. FULL IDENTIFICATION MARKINGS IN ACCORDANCE WITH MIL-STD-129-1 TO INCLUDE NSN AND ODDIC, QUANTITY AND NOMENCLATURE, LOT NUMBER AND GROSS WEIGHT OF THE LOAD, SHALL BE MARKED ON TAGS LOCATED ON OPPOSITE UPPER CORNERS OF THE LOAD.
- K. BAR CODE LABELS ARE REQUIRED ON THE STRAPS OF OPPOSITE CORNERS. SEE MIL-STD-129-1.
- L. THE SPECIAL PALLET WILL BE CONSTRUCTED AND ASSEMBLED IN ACCORDANCE WITH A MILITARY SPECIFICATION MIL-P-15011, STYLE 1, TYPE I, CLASS 1 PALLET WITH THE EXCEPTION THAT THE TOP AND BOTTOM DECK BOARDS WILL BE 44" LONG INSTEAD OF 48". ALL OTHER REQUIREMENTS SPECIFIED WITHIN MIL-P-15011 FOR A STYLE 1, TYPE I, CLASS 1 PALLET WILL APPLY TO THE PALLET SPECIFIED WITHIN THIS DRAWING.
- M. THE MODIFIED STYLE 1 PALLET DELINEATED IN THE DETAIL ON PAGE 5 NEED NOT HAVE CHAMFERS OR STRAP SLOTS AS SPECIFIED WITHIN MILITARY SPECIFICATION MIL-P-15011 WHEN USED FOR THE UNITIZATION OF THE ITEMS COVERED BY THIS APPENDIX.
- N. THE THICKNESS OF THE PLYWOOD BUFFER PIECES AS DEPICTED IN THE UNIT LOAD ON PAGE 5 MUST BE ADJUSTED, AS REQUIRED, TO COMPLY WITH THE DIMENSIONAL VARIANCE OF THE PA116 CONTAINERS, SO AS TO COMPLETELY FILL OUT THE PALLET. THE LENGTH DIMENSION OF THE PALLET UNIT AT THE PLYWOOD BUFFER PIECES MUST BE WITHIN THE TOLERANCE OF PLUS 1/4", MINUS 0" OF THE LENGTH DIMENSION AT THE TOP OF THE PALLET UNIT. NOTE: NOMINAL 1" X 6" MATERIAL MAY BE SUBSTITUTED FOR THE PLYWOOD IF IT WILL CAUSE THE PALLET UNIT DIMENSIONS TO FALL WITHIN THE TOLERANCES OUTLINED ABOVE, AND IF SO DESIRED.
- O. ALL DUNNAGE SHALL BE PRESERVATIVE TREATED IN ACCORDANCE WITH GENERAL NOTE "X" IN THE BASIC PROCEDURES.

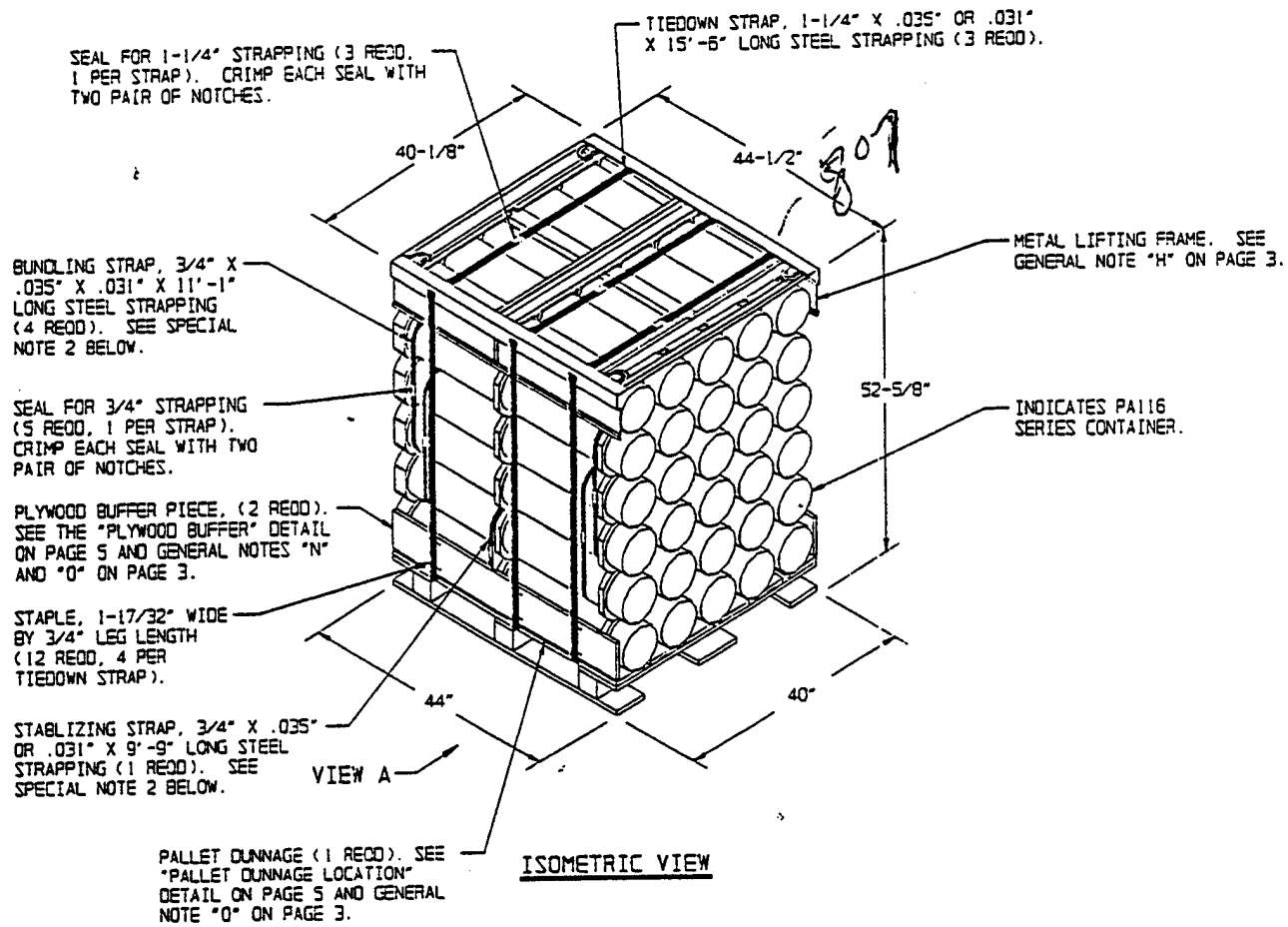

SPECIAL NOTES:

1. ALTHOUGH THE CONTAINERS DEPICTED IN THE UNIT LOAD ABOVE ARE CONSTRUCTED WITH INTERLOCKING DEVICES, THE INTERLOCKS WILL NOT FUNCTION PROPERLY UNLESS THE CONTAINERS ARE POSITIONED SO THAT THE "PINS" OF THE INTERLOCKS ARE IN AN UPRIGHT ORIENTATION. THIS ORIENTATION WILL PRECLUDE INTERFERENCE OF THE "PINS" AND THE PLYWOOD PALLET DUNNAGE AND WILL AID IN THE PREVENTION OF CONTAINER MOVEMENT, BOTH LATERALLY AND LONGITUDINALLY, DURING SHIPMENT OF THE UNIT LOAD.
2. BUNDLING STRAPS AND STABILIZING STRAP MUST BE TENSIONED AND SEALED PRIOR TO THE APPLICATION OF THE TIEDOWN STRAPS. ALL STRAPS MUST BE INSTALLED AS CLOSE AS POSSIBLE TO THE CONTAINER RINGS. **CAUTION:** STRAPS MUST NOT BE ALLOWED TO OVERLAP.

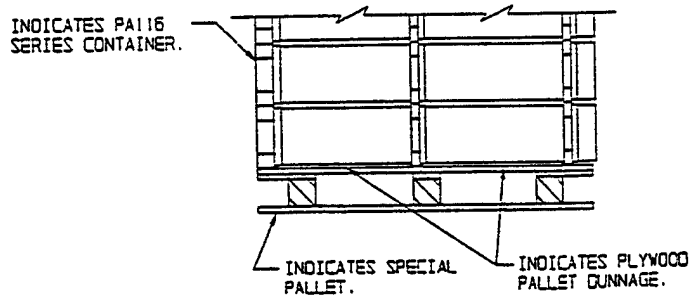

PARTIAL VIEW A
(PLYWOOD BUFFER HAS BEEN OMITTED FOR CLARITY).

UNIT DETAIL

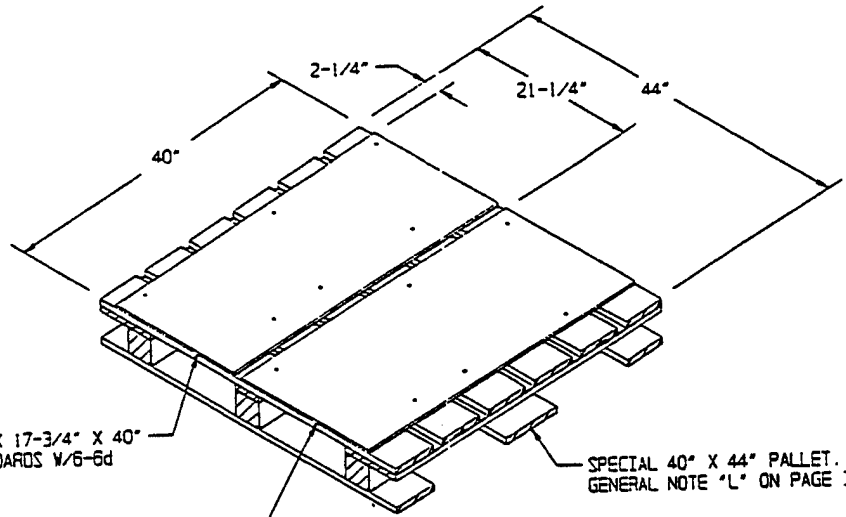

DECK DUNNAGE PLYWOOD, 3/8" X 17-3/4" X 40"
(1 RECD). NAIL THRU DECK BOARDS W/6-6d
NAILS AND CLINCH.

SPECIAL 40" X 44" PALLET. SEE
GENERAL NOTE "L" ON PAGE 3.

DECK DUNNAGE PLYWOOD, 3/8" X 18-3/4" X 40"
(1 RECD). NAIL THRU DECK BOARDS W/6-6d
NAILS AND CLINCH.

PALLET DUNNAGE LOCATION
SEE GENERAL NOTE "O" ON PAGE 3.

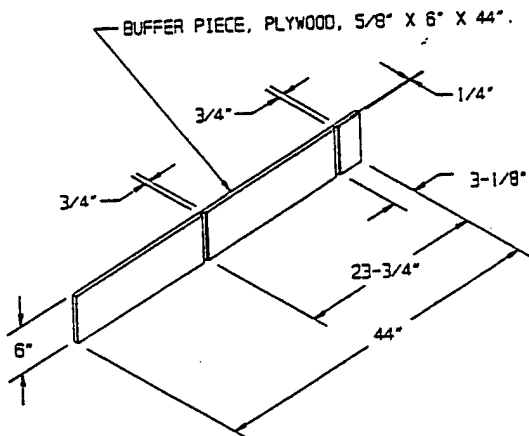

PLYWOOD BUFFER

SEE GENERAL NOTES "N" AND "O" ON PAGE 3.

BILL OF MATERIAL		
NAILS	NO. RECD	POUNDS
6d (2")	12	0.07
SPECIAL PALLET, 40" X 44"	1 RECD	77 LBS
STEEL STRAPPING, 3/4"	54.08' RECD	3.86 LBS
STEEL STRAPPING, 1-1/4"	46.50' RECD	6.64 LBS
SEAL FOR 3/4" STRAPPING	5 RECD	NIL
SEAL FOR 1-1/4" STRAPPING	3 RECD	NIL
PLYWOOD, 3/8"	10.14 SQ FT RECD	10.46 LBS
PLYWOOD, 5/8"	3.67 SQ FT RECD	6.30 LBS
STAPLES FOR 1-1/4" STRAPPING	12 RECD	NIL
METAL LIFTING FRAME	1 RECD	57 LBS

UNIT DATA

WEIGHT

CUBE	54.2 CUBIC FEET (APPROX)	
CONTAINER, PA116 SERIES	30 EA AT 75 LBS	2,250 LBS (APPROX)
DUNNAGE		85 LBS
PALLET		77 LBS
TOTAL WEIGHT		2,412 LBS (APPROX)

SPECIAL NOTES:

1. WHEN FIVE CONTAINERS ARE TO BE OMITTED FROM A PALLET UNIT, A COMPLETE LAYER OF CONTAINERS ARE TO BE OMITTED. WHEN FOUR CONTAINERS ARE TO BE OMITTED FROM A PALLET UNIT, A COMBINATION OF FILLER ASSEMBLIES DEPICTED ON PAGE 7 MUST BE USED. WHEN THREE OR LESS CONTAINERS ARE TO BE OMITTED FROM A PALLET UNIT, A COMBINATION OR ONE OF THE FILLER ASSEMBLIES DEPICTED ON PAGE 7 MAY BE USED. ALL FILLER ASSEMBLIES MUST BE INSTALLED IN THE MIDDLE OF THE LAYER OR LAYERS OF A PALLET UNIT.
2. WHEN A "FILLER A" ASSEMBLY IS USED IN COMBINATION WITH A "FILLER B" OR "FILLER C" ASSEMBLY THE "FILLER A" ASSEMBLY MUST BE POSITIONED IN THE SECOND LAYER OF CONTAINERS FROM THE TOP OF THE PALLET UNIT AND MUST HAVE ITS OVERALL HEIGHT REDUCED FROM 7-1/4" TO 7" AND ALSO 2" X 6" MATERIAL WILL BE SUBSTITUTED FOR THE 2" X 8" RIPPED TO 5-3/4" PIECES USED.
3. WHEN TWO "FILLER A" ASSEMBLIES ARE USED IN PLACE OF TWO OMITTED CONTAINERS, THE FILLER ASSEMBLIES WILL BE SEPARATED BY AT LEAST ONE CONTAINER TO INSURE PROPER FILLER ASSEMBLY RETENTION AND TO PRECLUDE ASSEMBLY INTERFERENCES.

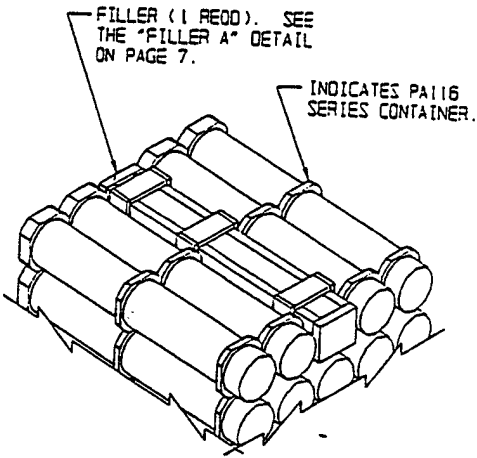

DETAIL A

THIS DETAIL DEPICTS PROCEDURES TO BE USED WHEN A STANDARD PALLET UNIT MINUS ONE CONTAINER IS TO BE UNITIZED. THE FILLER ASSEMBLY DEPICTED MUST BE INSTALLED IN THE MIDDLE OF THE TOP LAYER OF THE PALLET UNIT.

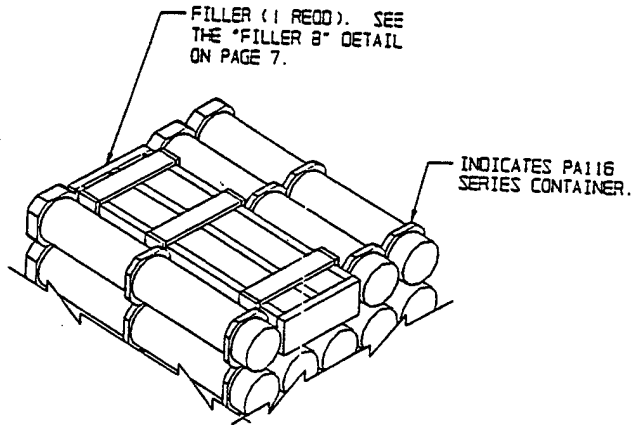

DETAIL B

THIS DETAIL DEPICTS PROCEDURES TO BE USED WHEN A STANDARD PALLET UNIT MINUS TWO CONTAINERS IS TO BE UNITIZED. THE FILLER ASSEMBLY DEPICTED MUST BE INSTALLED IN THE MIDDLE OF THE TOP LAYER OF THE PALLET UNIT.

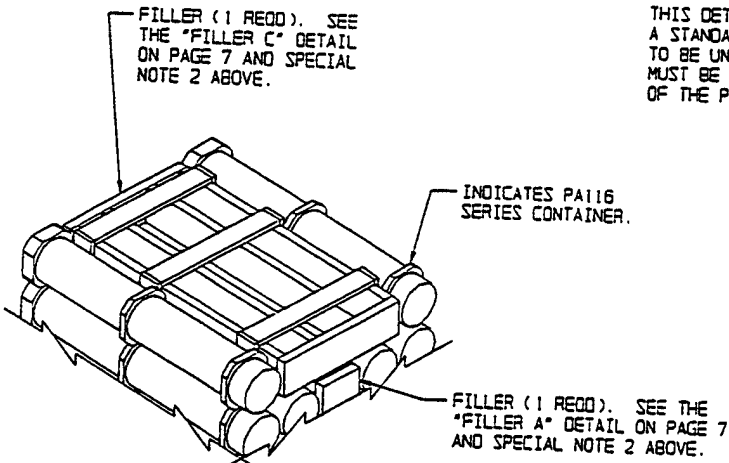

DETAIL C

THIS DETAIL DEPICTS PROCEDURES TO BE USED WHEN A STANDARD PALLET UNIT MINUS FOUR CONTAINERS IS TO BE UNITIZED. THE FILLER ASSEMBLIES DEPICTED MUST BE INSTALLED IN THE MIDDLE OF THE TOP LAYERS OF THE PALLET UNIT.

END BEARING PIECE, 2" X 8"
(RIPPED TO 5-3/4") X 7
(2 RECD). NAIL TO THE
TIE PIECES W/3-10d NAILS
AT EACH JOINT.

FILL PIECE, 1" X 4" X 7-1/4"
(6 RECD). NAIL TO THE TIE PIECE
W/2-6d NAILS AND TO THE STRUTS
W/2-6d NAILS AT EACH JOINT.

BELL END
OF FILLER
ASSEMBLY.

TIE PIECE, 2" X 8"
(RIPPED TO 5-3/4")
X 41-1/2" (2 RECD).

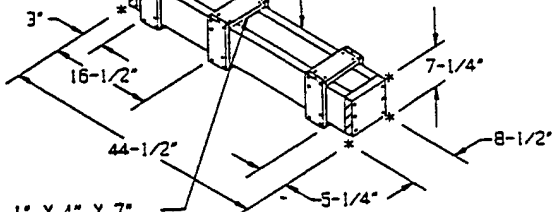

STRUT, 1" X 4" X 7"
(6 RECD). NAIL TO
THE TIE PIECES W/2-6d
NAILS AT EACH JOINT.

FILLER A

THIS FILLER IS TO BE USED WHEN ONE CONTAINER
IS TO BE OMITTED FROM A PALLET UNIT, OR IN
COMBINATION WITH OTHER FILLER ASSEMBLIES.

END BEARING PIECE, 2" X 8"
(RIPPED TO 5-3/4") X 14-7/8"
(2 RECD). NAIL TO THE
TIE PIECES W/3-10d NAILS AT
EACH JOINT.

FILL PIECE, 1" X 4" X 7-1/4"
(6 RECD). NAIL TO THE TIE PIECE
W/2-6d NAILS AND TO THE STRUTS
W/2-6d NAILS AT EACH JOINT.

BELL END OF FILLER
ASSEMBLY.

TIE PIECE, 2" X 8"
(RIPPED TO 5-3/4")
X 41-1/2" (3 RECD).

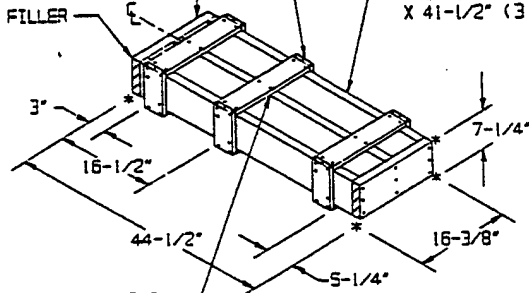

STRUT, 1" X 4" X 14-7/8"
(6 RECD). NAIL TO THE
TIE PIECES W/2-6d NAILS
AT EACH JOINT.

FILLER B

THIS FILLER IS TO BE USED WHEN TWO CONTAINERS
ARE TO BE OMITTED FROM A PALLET UNIT, OR IN
COMBINATION WITH OTHER FILLER ASSEMBLIES.

END BEARING PIECE, 2" X 8"
(RIPPED TO 5-3/4") X 22-5/8"
(2 RECD). NAIL TO THE TIE
PIECES W/3-10d NAILS AT
EACH JOINT.

FILL PIECE, 1" X 4" X 7-1/4"
(6 RECD). NAIL TO THE TIE PIECE
W/2-6d NAILS AND TO THE STRUTS
W/2-6d NAILS AT EACH JOINT.

BELL END
OF FILLER
ASSEMBLY.

TIE PIECE, 2" X 8"
(RIPPED TO 5-3/4")
X 41-1/2" (4 RECD).

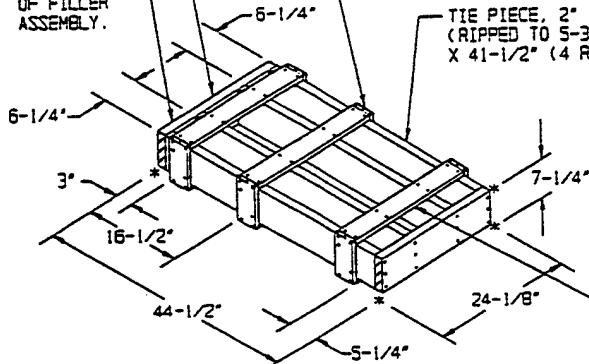

STRUT, 1" X 4" X 22-5/8"
(6 RECD). NAIL TO THE
TIE PIECES W/2-6d NAILS
AT EACH JOINT.

FILLER C

THIS FILLER IS TO BE USED WHEN THREE CONTAINERS
ARE TO BE OMITTED FROM A PALLET UNIT, OR IN
COMBINATION WITH OTHER FILLER ASSEMBLIES.

