

AECD - 2563

UNITED STATES ATOMIC ENERGY COMMISSION

USE OF FLUOROETHENE IN INFRARED
AND RAMAN SPECTROSCOPY

STI

ASTIA FILE COPY
ATI No. 105-4781

DISTRIBUTION STATEMENT A

Approved for public release
Distribution Unlimited

by

J. S. Kirby-Smith
E. A. Jones

Carbide and Carbon Chemicals Corporation (K-25)

This document is reproduced as a project report and is without editorial preparation. The manuscript has been submitted to The Review of Scientific Instruments for possible publication.

Date of Manuscript: February 7, 1949
Date Declassified: April 18, 1949

Issuance of this document does not constitute authority for declassification of classified copies of the same or similar content and title and by the same authors.

This copy is reproduced by direct photography from copy as submitted to this office.

Technical Information Branch, Oak Ridge, Tennessee
AEC, Oak Ridge, Tenn., 5-23-49--850-A4166

Printed in U.S.A. DTIC QUALITY INSPECTED 3

~~PRICE 5 CENTS~~

19961101 102

Handwritten initials

USE OF FLUOROTHENE IN INFRARED AND RAMAN SPECTROSCOPY

By J. S. Kirby-Smith and E. A. Jones

The recent development of fluorothene plastic¹ now makes available a new material for absorption and scattering cells of superior chemical resistance. The advantages of this material over the fully fluorinated compound (Teflon) are optical transparency, availability of a chemically resistant sealing wax² and the thermoplastic properties of the material which allow it to be welded. Raman and infrared spectra of many fluorine compounds that have been impossible to handle in the past may now be successfully studied.³ Some methods of fabricating fluorothene Raman tubes and infrared cells currently being used in this laboratory are outlined below:

The construction of Raman tubes is described in the following paragraphs. Cylinders of the material are first machined as shown at T in Figure 1.

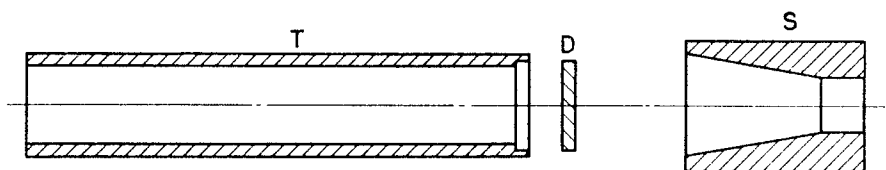

FIGURE 1

DETAILS OF SEALING FLUOROTHENE WINDOWS

The milky, translucent material is then polished, and optical clearing of the polymer carried out by heating to approximately 200°C in an oil bath. Above this temperature the milky appearance disappears and the material becomes very clear and transparent. It is then quenched by immersion in liquid nitrogen or a CO₂ acetone bath after which it retains most of its optical clarity. The material is given a final polish and is ready for fabrication into Raman tubes.

Completed tubes fabricated by two different methods are shown in Figure 2. The first (Fig. 2A) is made in the conventional form by heating and drawing one end of the polished cylinders to the desired shape.

1. Polymerized monochlorotrifluoroethylene. At present, the material is being manufactured by Carbide and Carbon Chemicals Corporation at Oak Ridge. Inquiries should be addressed to the Atomic Energy Commission, Oak Ridge, Tennessee.
2. Known locally as fluorothene-W. This is partially polymerized monochlorotrifluoroethylene, m.p. 70 - 90°C.
3. Jones, E. A., Parkinson, T. F. and Murray, R. B., J. Chem. Phys.; Woltz, P. J. H. and Jones, E. A., J. Chem. Phys.

This drawing process is difficult and it is not always possible to obtain the smooth curves desired. A polished fluoroethene window (D, Fig. 1), is placed in the shoulder at the end of the tube. A reasonably tight fit is desirable. Sealing is accomplished by pressing the end of the Raman tube inside a tapered metal plug (S, Fig. 1) heated to the required welding temperature (approximately 250 to 300°C).

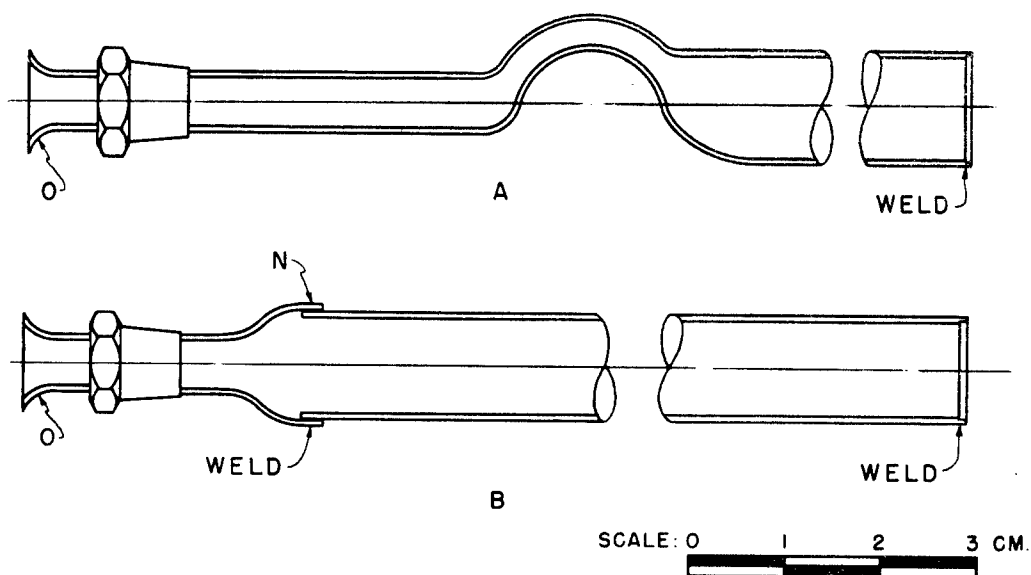

FIGURE 2

FLUOROTHENE RAMAN TUBES

Tubes of a second design (Fig. 2B) have proved very satisfactory, and since this type is easier to fabricate, it has been adopted for most of the work in this laboratory. The tapered section of fluoroethene (N, Fig. 2B) is welded to the body of the tube by the method given above for sealing windows. A close fitting metal support is temporarily introduced at the point N during this process in order to keep the tube from collapsing. The front window is then sealed in place. The flared ends (O, Fig. 2) are formed with the usual flaring tools heated to the softening point of the fluoroethene. Both welded seals and flared joints may be made vacuum tight without the use of additional sealing compounds.

These Raman tubes have been fabricated for use with liquid samples only and are relatively small, with outside diameters in the range 1 to 2 cm and a length of 10 to 15 cm. Wall thickness is approximately 1.5 mm. The tubes have been exposed to temperatures from 80°C to -170°C under operating conditions with no mechanical failures. The polymer has sufficient tensile strength and resistance to flow at 80°C to allow pressures of at least 2 atmospheres absolute to be used over long periods in tubes of the above dimensions. No appreciable flow has been noted after

exposures of 4 hours under these conditions. At lower temperatures, tubes of much larger dimensions can be used at higher pressures. Tubes of larger size (2 to 5 cm. diameter x 20 cm long) should allow the Raman spectra of corrosive compounds to be observed in the vapor phase.

The design of a fluorothene infrared cell is shown in Figure 3. The body of the cell (A, Fig. 3) and the inlet tube C are machined from fluorothene bars of the desired shape. The inlet tube is flared on one end for connection to a valve and threaded into the cell at B. A vacuum seal is obtained at B by coating the threads with fluorothene-W. The optical windows D are placed in the shoulders at the ends of the cell and fluorothene-W applied to the surface of contact. A vacuum-tight seal is obtained around the windows by gently heating in an oven until the wax flows.

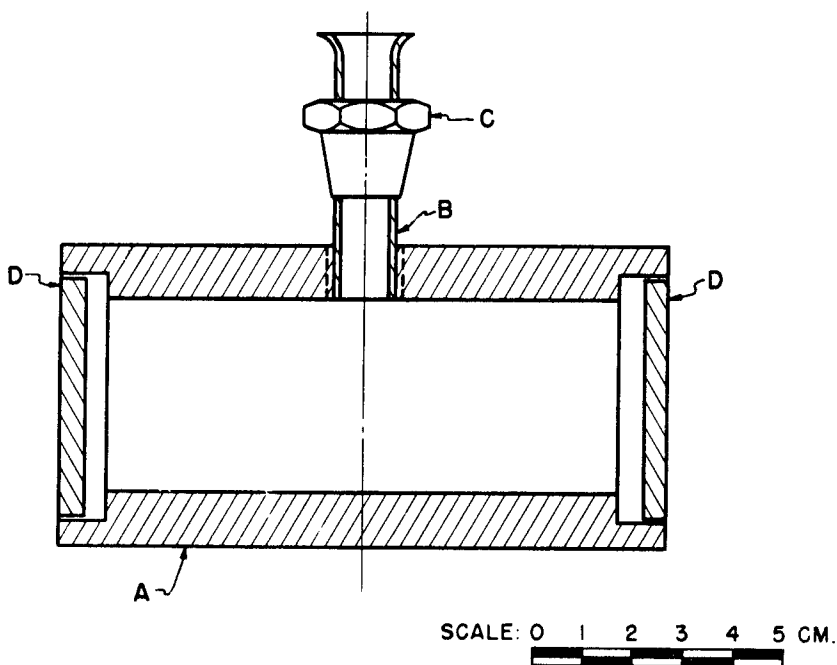

FIGURE 3

FLUOROTHENE INFRARED ABSORPTION CELL

Because of the poor infrared transmission of fluorothene at the longer wavelengths, (Figure 4), crystalline halide windows are used in most cases. Both NaCl and KBr have shown good corrosion resistance to many fluorine compounds. No difficulties have been encountered in sealing these window materials to the cells.

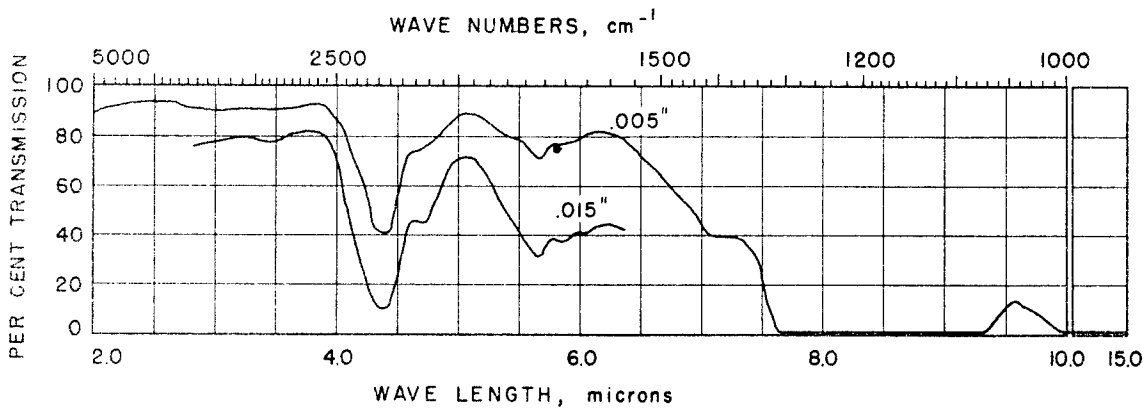

FIGURE 4

INFRARED TRANSMISSION OF FLUOROTHENE

The transmission of the cleared fluorothene is high throughout the visible spectrum and extends into the ultraviolet, dropping smoothly from 90% at 4000 μ to 30% at 2500 μ for a thickness of 1/16 of an inch. To date, the most serious objectionable optical property of the cleared polymer has been its optical activity. This arises from strains introduced during the clearing process and has prevented any quantitative polarization measurements of Raman lines. Work now in progress by the Plastics Section, Engineering Development Division, Plant K-25, indicates that these strains may be minimized by appropriate heat treatment.

We would like to acknowledge numerous suggestions on the handling of this material and measurements of its physical properties which have been given us by individuals throughout the K-25 Research and Engineering Development groups.

END OF DOCUMENT