

**Upgraded,  
Completely Vectored F-22**

**Flying Scaled Vectored F-22 to Maximize  
Post-Stall Agility: Towards Tailless,  
Completely Vectored, Future Designs**

**USAF, AFOSR-EOARD Contract F61708-92-W**

**B. Gal-Or**

Feb. 28, 1993

**The Jet Laboratory, Technion-IIT**  
Tel. 972-4-348-066, 972-4-292-807, Fax: 972-4-221-581

**DISTRIBUTION STATEMENT A**

Approved for public release;  
Distribution Unlimited

**DTIC QUALITY INSPECTED 2**

**19961113 136**

# REPORT DOCUMENTATION PAGE

Form Approved OMB No. 0704-0188

Public reporting burden for this collection of information is estimated to average 1 hour per response, including the time for reviewing instructions, searching existing data sources, gathering and maintaining the data needed, and completing and reviewing the collection of information. Send comments regarding this burden estimate or any other aspect of this collection of information, including suggestions for reducing this burden to Washington Headquarters Services, Directorate for Information Operations and Reports, 1215 Jefferson Davis Highway, Suite 1204, Arlington, VA 22202-4302, and to the Office of Management and Budget, Paperwork Reduction Project (0704-0188), Washington, DC 20503.

1. AGENCY USE ONLY (Leave blank)		2. REPORT DATE 28 February 1993	3. REPORT TYPE AND DATES COVERED Final Report	
4. TITLE AND SUBTITLE Flying Scaled Vectored F-22 to Maximize Post-Stall Agility: Towards Tailless, Completely Vectored, Future Designs			5. FUNDING NUMBERS F6170892W0240	
6. AUTHOR(S) B. Gal-Or				
7. PERFORMING ORGANIZATION NAME(S) AND ADDRESS(ES) Technion - Israel Institute of Technology The Jet Propulsion Laboratory, Department of Aerospace Engineering Technion City Haifa 32000, Israel			8. PERFORMING ORGANIZATION REPORT NUMBER SPC-92-4005	
9. SPONSORING/MONITORING AGENCY NAME(S) AND ADDRESS(ES) EOARD PSC 802 BOX 14 FPO 09499-0200			10. SPONSORING/MONITORING AGENCY REPORT NUMBER SPC-92-4005	
11. SUPPLEMENTARY NOTES Attached report, "Tailless Vectored Fighters: Theory, Laboratory, and Flight Tests," provides background information related to this report.				
12a. DISTRIBUTION/AVAILABILITY STATEMENT Unlimited			12b. DISTRIBUTION CODE	
13. ABSTRACT (Maximum 200 words) This report describes the first phase of an F-22 upgrading feasibility study, namely, the feasibility of applying complete Thrust-Vectored-Flight-Control (TVFC) to future designs of upgraded F-22 fighter aircraft. The report also describes the institute's proposals for future CFC-TVFC military and civil aircraft.				
14. SUBJECT TERMS			15. NUMBER OF PAGES 230	
			16. PRICE CODE	
17. SECURITY CLASSIFICATION OF REPORT UNCLASSIFIED	18. SECURITY CLASSIFICATION OF THIS PAGE UNCLASSIFIED	19. SECURITY CLASSIFICATION OF ABSTRACT UNCLASSIFIED	20. LIMITATION OF ABSTRACT UL	

## Summary

**C**omplete Thrust-Vectoring-Flight-Control [TVFC], by means of rapid, roll-yaw-pitch jet-deflections, was first developed and flight-tested by this laboratory.

It was first designed and laboratory tested in the early 80s [1]. It was then patent filed in 1986 [2] and flight-tested in 1987 [3].

In 1989 it was first flight-tested by means of flying powered 1/7-scale F-15 and 1/8-scale F-16 models.

This Report describes the first phase of an F-22 upgrading feasibility study, namely, the feasibility of applying complete TVFC to future designs of upgraded F-22 fighter aircraft.

The demonstration of that feasibility is based on theory, PWA-research project in this laboratory and flying powered, 1/8-scale, F-22 model.

F-22 Conventional Flight Control [CFC], Pitch-only TVFC, and mixed CFC-TVFC were successfully tested on Aug. 7, 1992 in Megiddo Airport in the presence of a US Air Force representative [Capt. D. Baumann].

The report also describes our unique, combat-effective, STOL, backup-flight-control/safety-multiplier proposals for future CFC-TVFC military and civil aircraft.

It also deals with future options of tailless vectored fighters, jet-cargo and jet civil aircraft and stresses that the current vulnerability, accuracy, terrain-following, maximum range/payload, stealth degrees and final super-maneuverability of unmanned jet-vehicles, including advanced stealth cruise missiles, can be significantly improved by resorting to a proper mix of complete TVFC with CFC.

## Introduction

Complete TVFC is independent of the external flow regime on the surfaces of CFC means. It is, therefore, expected to dramatically enhance post-stall [PST] agility and all flight safety standards in take-off, landing, cruise, conventional spin, loss of CFC and offensive-defensive combat.

For future superiority fighters, beyond the current design of the pitch-only-TVFC F-22, it introduces a new, low-cost technology, which generates unlimited new possibilities for gaining fighter maneuverability and controllability in conventional and post-stall domains.

It also provides lower fuel consumption via TVFC replacing CFC-trim in cruise.

TVFC-upgrading can also provide higher range and/or payloads for any given CFC-aircraft. Moreover, it opens the way to the design of tailless fighter aircraft, with reduced thermal, optic and radar signatures. Tailless cargo and civil aircraft may therefore become feasible at similar-to-current-production costs but with higher degrees of effectiveness, safety and environmental standards.

## Upgraded F-22 Feasibility Study

The feasibility of upgrading the pitch-only-TVFC F-22, by adding fast-responding-yaw TVFC, has been studied. The study includes the development of new, fast-responding-yaw-pitch-TVFC-nozzles and the actual flying of scaled prototypes to define relative and absolute, maximized, F-22-TVFC-agility-controllability limits.

Maximized pitch agility has been demonstrated on Aug. 7, 1992 by a flying, powered, F-22 model performing the fastest possible 'Cobra-type', rotating-reversing, post-stall maneuvers. Maximized F-22 nose-turning rates were extracted by a proper mix of

CFC commands with TVFC ones. A tailless TVFC-F-22 is currently under a non-contracted study.

**Phase I** of this effort is to establish a pitch-only TVFC reference performance, namely, the maximized conventional and post-stall agility-controllability extractable by pitch-only CFC-TVFC.

**Phase II** of this effort is to quantify the added relative and absolute maximum performance possible with yaw-pitch TVFC nozzles funded here by **Pratt and Whitney**. That added performance is to be quantified vis-a-vis phase-I reference performance.

## **The Complete TVFC-Engine Nozzles**

**T**he Gal-Or/Technion/PWA yaw-pitch TVFC nozzles are currently being developed and tested on this laboratory jet-engine test facility for maximized yaw-pitch effective jet-deflections and for optimized internal nozzle configuration. During late 1993 and in 1994, using the **PWA funding for 1993 and 1994**, these nozzles will be scaled-down and flight-tested with a scaled F-22 prototype to define the added relative and absolute maneuverability, handling qualities and general performance.

## **The Feasibility of Tailless F-22**

**P**hase III of this effort [not negotiated nor contracted yet], is to flight test Phase-II TVFC-F-22 prototypes as **Tailless F-22s**.

Unfunded phase III is designed to include onboard computer/instrumentation to measure **Post-stall G-load histories** on the pilot during new, yaw-pitch, TVFC-enhanced maneuvers.

# Thrust Vectoring Flight Control For Superiority Fighter Aircraft

## Part I: Theory

### Definitions

The forthcoming availability of post-stall [PST], thrust vectoring flight-controlled [TVFC] fighters, helmet-sight-aiming systems and all-aspect missiles, requires reassessment of the optimal balance between aircraft agility and effectiveness, and those of missiles. Whatever is the aforementioned balance, high-performance fighter aircraft will gradually include PST-TVFC capability.

TVFC is subdivided into three categories:

- 1 - *Pitch-only TVFC*. The new superiority fighter, the F-22, belongs to this category.
- 2 - *Yaw-pitch TVFC*.
- 3 - *Roll-yaw-pitch TVFC*.

In twin-engine aircraft category 2 becomes 3 and roll effectiveness depends on the distance between nozzles [not necessarily between engines], and on maximum pitch jet deflections values. Category 3 is defined here as **complete TVFC**.

Maximized aircraft agility-controllability is extractable when complete TVFC is properly mixed with conventional flight control [CFC]. That mix is henceforth defined as **CFC-TVFC**.

The aim of this work is to examine the added agility-controllability of complete TVFC vs Pitch-Only TVFC, with and without CFC. That examination is based on:

- (i) - *Theoretical studies of TVFC-induced-agility [4] and similarity transformations.*
- (iii) - *TVFC nozzles tested on a jet engine in the laboratory;*
- (iv) - *Dynamically scaled CFC-TVFC-model flight tests.*

### **Expected Added Performance of Yaw-Pitch vs Pitch-Only Vectoring**

Complete TVFC, especially by means of roll-yaw-pitch, two-dimensional, jet-engine nozzles, is a new and highly promising alternative method of flight control for future military and civil aircraft.

Current vulnerability, accuracy, terrain-following, maximum range/payload, stealth degrees and final super-maneuverability of unmanned jet-vehicles, including advanced stealth cruise missiles, can also be significantly improved by resorting to a proper mix of CFC with TVFC [4-21].

Complete TVFC is independent of the external flow regime on the surfaces of CFC surfaces. It is, therefore, expected to dramatically enhance all flight safety standards in take-off, landing, cruise, conventional spin, loss of CFC and offensive-defensive combat.

For future superiority fighters, beyond the current design of pitch-only-TVFC F-22, it introduces a new, low-cost technology, which generates unlimited new possibilities for gaining fighter maneuverability in the conventional and the new post-stall domains. It also allows different cruise trim, lower fuel consumption, higher range and/or payloads and opens the way to the design of tailless fighter aircraft, with reduced thermal, optic and radar signatures. Tailless cargo and civil aircraft may therefore become feasible at similar-to-current-production costs, but with higher degrees of effectiveness, safety and environmental standards.

## Mission Reassessment

Using complete TVFC mixed with CFC one can yaw-pitch-roll-point the nose/weapon at the enemy faster than with CFC, or faster than with just pitch-only TVFC. A proper mix increases kill-ratio probabilities [4] to destroy the target prior to its launching its weapon, for otherwise the probabilities of mutual destruction increase dramatically. Consequently, aircraft PST-CFC-TVFC-induced agility must be well-integrated with missile's PST-agility and initial vectoring conditions.

In multi-target situations the expected kill ratio of a CFC-TVFC-fighter over a similar, but CFC-fighter, increases from 3, in 1 vs 1 engagements, to 8, in 4 vs 4 engagements [4]. Survivability is also expected to increase in various new, air-to-air, PST-CFC-TVFC-induced, defensive maneuvers.

Such new developments require reassessment of all conventional flight-control concepts, including the development of a new research, development and flight-testing methodology for integrated propulsion and flight-control criteria.

An attempt to develop such a methodology is depicted in Fig. 1 and described in Ref. 4 and below.

Complete TVFC requires reassessment of air-to-ground multi-target, yaw-TVFC capabilities during a single pass [4]. In offensive air-to-air engagements it provides enhanced ability to perform the fastest turn back [Herbst] maneuver, pure sideslip maneuvers [PSM], and other combat critical maneuvers requiring yaw and roll TVFC.

## The First Vectoring Control Rule

Whenever CFC-TVFC is required, the jet-rotation rates should not lag behind the maximum rotation rates extractable from advanced conventional elevators, rudders and ailerons. Therefore, effective TVFC rates cannot lag behind the conventional ones.

This basic effectiveness rule forces the selection of the fastest jet-deflecting TVFC-nozzle for new or upgraded fighter aircraft. As indicated by our PWA project-contract [11, 13], it means the selection of two-dimensional [2D] TVFC nozzles over the axisymmetric ones. We return to this subject in Part II of this Report.

### Maximized Agility and Dynamic Scaling

With the rapid advance of new technologies, engagement times get shorter, and the minimization of inherent delay-times of TVFC-nozzles, pilot, and TVFC hardware, become more critical to combat effectiveness. Hence, to simulate TVFC-controllability by flying powered scaled models, we define Aircraft Gross Agility [AGA] as

$$AGA = MGA[DSF]F_1[\text{Turb.-MLEM}]F_2[\text{PDT/FDT}]F_3[\text{A-IFPC}]/[\text{M-IFPC}] \quad [1]$$

where MGA is the scaled Model Gross Agility, DSF the Dynamic Scale Factors, to be defined below,  $F_1[\text{Turb.-MLEM}]$  the functions of 'Turbulence Noise and Maximum Likelihood Estimation Method',  $F_2[\text{PDT/FDT}]$  the ratio of pilot to flyer delay times during actual, in-flight SACOM, and  $F_3[\text{A-IFPC}]/[\text{M-IFPC}]$  the control functions relating aircraft Integrated Flight Propulsion Control [IFPC], to model-IFPC.

Without stating it, eq. 1 assumes that each vehicle is characterized by a hidden, *bona fide*, net agility - a basic combat-technological quality that the propulsion/airframe designer and the theoretician both want to uncover and maximize.

The differences in aerodynamic effects between model and full-scale aircraft are of 'second-order' in comparison with moments-of-inertia-related angular velocities & accelerations. This approximation is justified especially for high Reynolds number ranges and for a strict proportional size-shape similarity between the full-scale aircraft and scaled models

## Radius of Gyration

The inertia tensor,  $I_{ij}$  ( $i, j = 1, 2, 3$  or  $x, y, z$ ) can be divided into an inertial tensor relative to the center of mass of the aircraft, and an inertia tensor relative to another point of reference. Hence, the quantities associated with it - principal axes, principal moments, etc. - are relative to a particular point of reference.

If the reference point is shifted from the center of mass of the aircraft to another point, as is required for improved understanding of PST-TVFC rotational-agility, these quantities change accordingly. The combined translational-rotational dynamics during, say, pure-pitch SACOM, may, similarly, be split into two separate formulations, one purely translational and the other purely rotational about a reference point.

To simplify the formulations of rigid-body rotational dynamics and flight tests of PST-TVFC vehicles, we first examine the radius of gyration, a fundamental quantity which is directly related to the moments of inertia.

For instance, the radius of gyration around the pitch axis of the rotating PST-TVFC aircraft, or the F-22 flying model,  $R_y$ , is defined by

$$R_y = [I_{yy}/m]^{0.5} \quad [2]$$

where  $m$  is the mass of the flying vehicle.

Flight tests conducted by this laboratory [see below] employ the radius of gyration formulation to extract improved understanding of pilot tolerances in scaled, TVFC F-15, F-16 and F-22 fighter aircraft upgrades. The main question is, therefore, what is a dynamically-scaled PST-TVFC model, and, in particular, what should be its weight and moments of inertia with respect to the emulated fullscale aircraft. For that purpose one must, first and foremost, transform Aircraft-to-Model [AtM] moments-of-inertia as *correctly* derived below.

## Model vs Aircraft Dynamic Similarity

Eqs. 1 and 2 require a prudent simultaneous integration of a number of similarities between flying, rotating-translating, PST-TVFC aircraft and the emulating powered model. The main PST-TVFC similarities involved are ten in number:

SACOM, geometric, inertial, vectoring, propulsive, aerodynamic, IFPC, pilot/flyer, atmospheric and aeroelastic.

### Geometric-Aerodynamic-Inertial Similarity

As with wind-tunnel models we first request a strict geometrical similarity between aircraft and model to roughly approximate aerodynamic similarity beyond a certain high Reynolds number value for both model and aircraft, viz.,

$$[dx_i]_A = L [dx_i]_M \quad i = 1, 2, 3, \text{ or } x, y, z, \text{ and/or } r_A = L r_M \quad [L > 1] \quad [3]$$

where the subscripts M and A refer to model and full-scale aircraft, L is a constant scaling factor, and r the vehicle's symmetric external-shape radius.

Now,  $I_{yy}$  reflects the need for similarity in terms of the moments-of-inertia components under air and/or no-air, gravity and/or zero-gravity conditions. Its proper transformation should be based only on the basic definition of the moment of inertia in physics, with no presuppositions involving Froude number, or boundary-layer terminology. Hence,

$$\begin{aligned} [I_{ij}]_M &= \bar{\rho}_M \int_{V_A} L^{-2} r_A^2 L^{-3} [dx_i]_A = \\ &= \bar{\rho}_M L^{-5} \int_{V_A} r_A^2 [dx_i]_A = [I_{ij}]_A [\bar{\rho}_M / \bar{\rho}_A] L^{-5} \end{aligned} \quad [4]$$

where, for the full-scale aircraft

$$\int_{V_A} r_A^2 [dx_i]_A = [I_{ij}]_A / \bar{\rho}_A \quad [5]$$

and  $\bar{\rho}$  is the vehicle's average density.

From the basic eq. 4 and Newton's 2nd law,

$$[G_i]_M = [G_i]_A \quad [6]$$

Eq. 6 means that the 'g-loads' acting on the pilot and airframe are the same as those monitored by the flying model during SACOMs. From eq. 4 and Newton's 2nd law,

$$V_A = V_M (L)^{1/2} \quad [7]$$

$$\text{Model SACOM Time} = [\text{Fullscale SACOM time}](L)^{-1/2} \quad [8]$$

The vehicles ratio  $\bar{\rho}_M / \bar{\rho}_A$  is generally defined by

$$W_{M\bar{e}} = g \bar{\rho}_M L^{-3} \int_{V_A} [dx_i]_A = W_A L^{-3} [\bar{\rho}_M / \bar{\rho}_A] \quad [9]$$

Substituting eqs. 4 and 9 in 2 one obtains

$$[R_y]_A = L[R_y]_M \quad [10]$$

Eqs. 4 to 10 are fundamental physical formulations which remain valid irrespective of any linear fluid dynamics or boundary-layer models, Froude Number formulations, or other presuppositions [14-21]. Hence they form the basis to our generalized similarity transformations.

Moreover, using 10 and 2, one can introduce the radius-of-gyration methodology to emulate PST-TVFC-induced g-loads on pilots and airframe, as well as design emulating centrifuges for TVFC pilots.

## Powered vs Drop-Model Methodologies

Previous USAF-NASA free-flying and drop-model methodologies have provided no TVFC moments, nor any PST-TVFC similarity. Moreover, prediction of drag is distorted by clogged engine inlets.

Despite these limitations unpowered drop and free flying models conforming to eq. 4

may approximately emulate CFC-aircraft agility-controllability limits. However, they cannot emulate nor predict current and future TVFC-agility-controllability relative and absolute limits. Hence, such unpowered models become useless for emulating CFC-TVFC-aircraft, such as the F-22, or the vectored F-15, F-16, F-18 and X-31.

Maintaining stick-command similarities under the same TVFC-SACOM is a basic similarity requirement via eq. 1. Hence, unpowered free flying or drop models cannot emulate or predict TVFC or CFC-TVFC-aircraft performance.

Maintaining similarities in materials, servo-actuator systems and avionics-hardware is, *a priori*, assumed impossible.

Despite these difficulties one may attempt to uncover the hidden, net, or relative agility, expressed by eq. 1, by using dynamically scaled powered models. Generating such an attempt is a prerequisite for this study.

Under these conditions we have previously derived another similarity, viz.,

$$[\tilde{\rho}_A/\tilde{\rho}_M][\rho_{aM}/\rho_{aA}] = 1 \quad [11]$$

Eq. 1 combined with eqs. 4 and 11 form the fundamental requirements of powered model emulation or prediction of full-scale performance. Eq. 11 dictates the use of high-density powered models. These, in turn, may be unflyable for technology, budget, or safety limitations.

Flight data extracted from low-cost, light, powered models, which had been correctly designed and constructed via eq. 4, may be adjusted to fit with eq. 1 and 11 via a density iterative process [see Appendix].

## Part II: Laboratory & Flight Tests

Phase I of this effort has established a fast-responding-pitch-only-TVFC reference performance, namely, the maximized conventional and post-stall agility-controllability extractable by pitch-only CFC-TVFC. Phase-I work is covered by this Report.

Phase II of this effort is to quantify the added relative maximum performance possible with novel, unique, yaw-pitch TVFC nozzles funded here by Pratt and Whitney. No Phase II flight tests have yet been conducted.

The expected added performance is relative to the phase-I reference performance.

The Gal-Or/Technion/PWA yaw-pitch TVFC nozzles are currently being developed and tested on this laboratory jet engine with optimized/maximized yaw-pitch internal nozzle configuration.

During the late 1993 and in 1994, **using the PWA funding**, these nozzles will be scaled-down and flight-tested with a scaled F-22 prototype to define the added relative performance.

Phase III of this effort [not contracted yet], is to flight test Phase-II TVFC-F-22 prototypes as **Tailless F-22s**.

This report, and the two video tapes [of March 31, 1992 and of Aug. 31, 1992] associated with it, document the predesign, design, construction and flight tests of Phase-I vectored F-22 prototype.

Unfunded phase III is designed to include onboard computer/instrumentation to measure **Post-stall G-load histories** on the pilot during new, fast-responding-yaw-pitch, TVFC-enhanced maneuvers.

### Laboratory Test Facilities

Our laboratory and flight-testing methodology is depicted in **Fig. 1**. It is based on extensive jet-engine tests in the laboratory. The jet engine is equipped with novel vectorable nozzles. Extracting optimized internal nozzle configurations and maximized efficiencies are the main targets of these tests. Funding for these laboratory tests is provided by PWA.

Three complementary methods are employed :

- (i)- Static 'subscale' tests [**Figs. 2 and 3**];
- (ii)- Static 'full-scale' tests [**Fig. 4**];
- (iii)- Dynamic 'subscale' tests by means of flying 'dynamically-scaled', PST-TVFC, powered prototypes [Cf., e.g., **Fig. 5** and Appendix].

Being properly integrated with a new mathematical phenomenology for PST-TVFC [5-12], these tests help the search to maximize PST-TVFC-agility [3].

A few inlet test results are depicted in **Figs. 6 and 7** for a 'vectorable-lip-sub-scale F-15 inlet'. The data indicate that a major distortion problem evolves beyond about 60 degrees AoA, thereby demonstrating an increasing need for inlet 'vectorable' lips during deep PST-maneuvers for both model and full-scale vehicles.

The 'full-scale' test rig is based on a jet engine equipped with novel yaw-pitch, or yaw-pitch-roll thrust-vectoring nozzles [**Figs. 9-10**]. These are scaled-up versions of similar 'sub-scale' TVFC-nozzles. They were flight tested in 1987 aboard the 1st TVFC vehicle in the history of aviation.

### Axi Vs Two-Dimensional Engine Nozzles

Most axi-TV-nozzle-delay-times result from excessive complexity and the high inertia/friction associated with a large number of moving/sliding flaps/spacers and extra rings and sliding rods-ducts [**Fig. 11**]. Moreover, the divergent flaps/spacers touch each other under maximum TV geometric deflections, thereby restricting maximum possible TVFC-deflection angles.

In comparison, there are only a few, non-sliding, rotating/deflecting flat vanes/flaps in

yaw-pitch 2D nozzles. In comparison with the rounded nozzles the 2D ones can be rotated at considerable faster rates.

Both 2D and axi TVFC-nozzles are practically similar from the combined point of view of engine reliability, performance, after-burner design, airframe structural reinforcement, actuators-sizes, and structure/weight/control/cost criteria required for adding TVFC.

However, our internal yaw vanes may present extra cooling requirements. Yet, this cooling technology is well known, and is currently employed for cooling advanced, 1st-stage, turbine stators. Provided the cooling requirements are met, the fast-responding-yaw-pitch-TVFC-2D nozzles must be selected via the aforesaid vectoring rule, for they provide the maximum possible jet-deflection rates.

Slow, ineffective rate-factors are associated with external TVFC-paddles, of the type being flight tested on the X-31 and F-18.

Therefore, success criteria in air-to-air and in air-to-ground combat, or under STOL or spin-avoidance-recovery conditions, include super-fast-responding yaw-pitch or yaw-pitch-roll 2D TVFC-nozzles. Consequently, such engine nozzles are being developed in this laboratory via the PWA funding.

Its design, constructing stages and internal equipment have been documented in Video Tape 'F-22', submitted on March 31 to USAF-AFOSR-EOARD.

Table I provides F-22 mass and moments of inertia data. The 'empty' data should normally be used, for the SACOM is performed with little left-over fuel.

## Table I

### F-22 Prototype [1/8-scale, CFC-TVFC] Moments of Inertia

<u>Empty</u>	<u>With Fuel</u>
$I_{xx} = 0.814 \text{ kg.m}^2$	$I_{xx} = 0.827 \text{ kg.m}^2$
$I_{yy} = 3.49 \text{ kg.m}^2$	$I_{yy} = 3.67 \text{ kg.m}^2$
$I_{zz} = 4.298 \text{ kg.m}^2$	$I_{zz} = 4.42 \text{ kg.m}^2$
[cross-coupled values are negligible]	
Mass = 12.37 kg	Mass = 12.77 kg

Thrust: 78.4 N

## CFC-TVFC F-22 Prototype Flight Tests

Laboratory and flight tests of the CFC-TVFC F-22 Prototype are documented in Video Tape No. 10 submitted on Aug. 31 to USAF-AFOSR-EOARD, UK. Table II provides the Pitch-SACOM results based on the Aug. 7, 92 first flight tests and the DIP methodology [Appendix].

The relative pitch agility enhancement ratio, as indicated by the F-22 Max Pitch Ratio[Combined CFC-TVFC/Conventional], is equal 2.55 in comparison with 1.8 for the yaw-pitch-CFC-TVFC F-15 prototype [10].

The maximized pitch rate was reached at about 50 deg teta. It went to zero at 110 deg teta. It then reached a 2nd maximum pitch rate at about zero deg teta.

Table II

## Pitch-SACOM Flight Results for The F-22

Based on the Aug. 7, 92 first flight tests.

### Conventional Pitch-SACOM

Actual flight  $q_{\max} = 116$  deg/sec

Full-Scale  $q_{\max} = 31$  deg/sec

### Combined CFC-TVFC Pitch-SACOM

Actual flight  $q_{\max} = 180$  deg/sec

Full-Scale  $q_{\max} = 79$  deg/sec

### F-22 Max Vectoring Pitch-Rate Enhancement Ratio

[Combined CFC-TVFC/Conventional] = 2.55

F-22 prototype flight tests were conducted at Megiddo airfield on Aug. 7, 1992. Conventional [CFC], vectoring-only [TVFC], and CFC-TVFC pitch SACOMs started from sustained level flight at about 300 ft altitude.

Only CFC and/or TVFC rapid step-function commands were used. During the resulting cobra-type maneuvers [cf., e.g., Figs. 15, 16], the CFC-TVFC F-22 model rapidly reversed its rotation twice. The first reversal took place at about 110 degrees positive  $\theta$ , while the 2nd one was at about minus 80 degrees.

The maneuver is called 'double-cobra'.

## Preparations For Phase II

Fig. 17 pictures the novel Gal-Or/Technion/PWA yaw-pitch TVFC nozzle developed and tested on the 'full-scale' test facilities of this laboratory. Within Phase II it is to be scaled-down, installed, calibrated, and flight tested with the same 1/8-scale F-22 model. [Its internal design is not to be reported here.]

The 1/8-scale F-22 model is shown in **Figs. 18 and 19**. The configuration has also been shaped by our Auto-CAD computer program. The program allows F-22 rotation to simulate PST maneuvers.

Depending on the full-scale F-22's thrust-to-weight-ratio, stability margin, hardware/software flight control and Flyer's delay-times, Mach number, altitude and SACOM duration, the full-scale F-22 may gain altitude prior to reversing the rotation during a positive 'Cobra' maneuver, while the flight-path is consistently downward during a negative 'Cobra' maneuver.

Computer simulations of this pitch-SACOM have been investigated by this team for CFC-TVFC F-15 and F-22 models and full-scale prototypes. The results are beyond this contract requirements.

## Concluding Remarks

**T**he first phase of a feasibility study concerning upgrading options of the pitch-only-CFC-TVFC F-22, by adding fast-responding-yaw TVFC, has been completed.

- An unfunded future study may include the development of new, fast-responding-yaw-pitch-TVFC-nozzles and the actual flying of scaled prototypes to define relative and absolute, maximized, F-22-TVFC-agility-controllability limits.
- Maximized pitch agility has been demonstrated on Aug. 7, 1992, by the fastest possible 'Double Cobra-type', rotating-reversing, post-stall maneuvers.
- Maximized F-22 nose-turning rates are extracted by a proper mix of CFC commands with TVFC ones.
- Laboratory and flight tests of the F-22 model are documented in Video Tape No. 10 submitted on Aug. 31 to USAF-AFOSR-EOARD, UK.
- Table II provides the Pitch-SACOM results based on the Aug. 7, 92 first flight tests and the DIP methodology [Appendix].
- The relative pitch agility enhancement ratio, as indicated by the F-22 Max Pitch

Ratio[Combined CFC-TVFC/Conventional], is equal 2.55 in comparison with 1.8 for the CFC-TVFC F-15 prototype.

- A tailless TVFC-F-22 is now under construction and early laboratory tests.
- This report, and the two video tapes [of March 31, 1992 and of Aug. 31, 1992] associated with it, document the predesign, design, construction and flight tests of Phase-I vectored F-22 prototype.
- Unfunded phase III is designed to include onboard computer/instrumentation to measure **Post-stall G-load histories** on the pilot during new, yaw-pitch, TVFC-enhanced maneuvers.

### Acknowledgments

Part of this research has been financially sponsored by the U.S. Air Force Office of Scientific Research, EOARD, U.K., General Dynamics, General Electric, Teledyne and Pratt and Whitney.

### References

- 1 - Gal-Or, B. "Two-Dimensional Thrust-Vectoring Engine Nozzles", Internal reports [1982-4]. Also C. Cherulnik's M.Sc. Thesis, Technion-IIT, [1984]. See also Gal-Or's Review of the history of vectored propulsion pitch-only and reversing thrust vectoring engine nozzles published in Ref. 4 and in the *Intern. J. Turbo & Jet-Engines*, 1, 183-194, 1984.
- 2 - Gal-Or, B., "Flight-Control for Jet-Propelled Aircraft and Spacecraft", [Israel] 80532 Patent Applied on Nov. 7, 1986.
- 3 - Anon, "Israelis flight Test Jet-Powered RPV Fitted With Thrust-Vectoring Nozzles", *AVIATION WEEK & SPACE TECHNOLOGY*, May 18, p. 21, 1987
- 4 - Gal-Or, B., "Vectored Propulsion, Supermaneuverability and Robot Aircraft", Springer Verlag, N.Y., Heidelberg, 1990, 1991. Also "The Fundamental Concepts of Vectored Propulsion", [AIAA] *J. Propulsion*, Vol. 6, No. 6, Nov.-Dec., pp. 747-757, 1990. Also

- "Maximizing Post-Stall, Thrust-Vectoring Agility and Control Power", [AIAA] J. Aircraft, Vol. 29, No. 4, 647-651, 1992. Also "Fundamentals and Similarity Transformations of Vectored Aircraft", AIAA J. Aircraft. In press.
- 6 - Gal-Or, B. and V. Sherbaum, Thrust Vectoring: Theory, Laboratory and Flight Tests-II, Israel Aeronautics Conference Proceedings, Feb. 24, 1993, and ASME J. Power, in press.
- 7 - Gal-Or, B., Novel, Post-Stall, Thrust-Vectored F-15 RPVs: Laboratory and Flight Tests, Flight Dynamics Laboratory, WPAFB, USAF-AFOSR-EOARD, AFOSR 89-0445 (April 1, 1989 - June 30, 1991), April 24, 1990.
- 8 - Gal-Or, B., Tailless Vectored Fighters, Flight Dynamics Directorate, WPAFB, USAF-AFOSR-EOARD, AFOSR 89-0445 (April 1, 1989 - June 30, 1991), July 15, 1991.
- 9 - Gal-Or, B., Dynamic Scaling of Prototypes Using Radius of Gyration Method: Theory, Laboratory and Flight Tests, AL & Flight Dynamics Directorate, WPAFB, USAF-AFOSR-EOARD, AFOSR SPC-91-4003, (Aug 1, 1991 - Sep 30, 1991), July 15, 1991.
- 10 - Gal-Or, B., Vectored F-15 and F-22, Flight Dynamics Directorate, WPAFB, USAF-AFOSR-EOARD, F7LEOA-2015S600 & SPC-91-4003, Aug. 31, 1992.
- 11 - Gal-Or, B., The Feasibility of Yaw components in 2D Vectoring Nozzles, Pratt and Whitney, Aug. 31, 1992.
- 12 - Ibid, "The Principles of Vectored Propulsion", Intern. J. of Turbo and Jet-Engines, Vol. 6, Oct. 1989, pp. 1- 15.
- 13 - Herrick, P., "Fighter Aircraft Affordability, Survivability and Effectiveness through Multi-Function Thrust-Vectoring Nozzles", Intern. J. Turbo & Jet Engines, Vol. 8, 1991.
- 14 - Chambers, J. R. "Status of Model Testing Techniques", AFFDL/ASD Stall/Post-Stall/Spin Symposium, WPAFB, Ohio, Dec. 15-17, 1971.
- 15 - Woodcock, R. J. "Some Notes on Free-Flight Model Scaling", AFFDL-TM-73-123-FGC, WPAFB, 73-26, 636, Aug. 1973.
- 16 - Stuart, J. L., B. D. Segal and C. H. Bowser, "Conduct and Results of YF-16 RPRV Stall/Spin Drop Model", AFFTC-TR-76-42, 1977
- 17 - Chambers, J. R. and K. W. Illif, "Estimation of Dynamic Similarity Parameters from Drop Model Flight Tests", AFFDL/WPAFB, Internal Report, 1981.
- 18 - Wolowicz, C. H., J. S. Bowman and W. P. Gilbert, "Similitude Requirements and Scaling

Relationships as Applied to Model Testing", NASA Tech. Paper 1435, Aug. 1979.

19 - Yip, L. P., H. M. Ross and D. B. Robelen, "Model Flight Tests of a Spin-Resistant Trainer Configuration", AIAA J. Aircraft, Vol. 29, No. 5, Sep.-Oct. 1992, pp. 799-805

20 - Gal-Or, B., V. Sherbaum, M. Lichtsinder and M. Turgeman, "Thrust Vectoring Flight Control For Fighter and Civil Aircraft, Part I : On The Vectored F-22 Superiority Fighter", Intern. J. Turbo & Jet Engines, 1993. In press.

21 - Gal-Or, B. "Thrust Vectoring Flight Control For Fighter and Civil Aircraft , Part II : Future Vectored Civil Aircraft", Intern. J. Turbo & Jet Engines, 1993. In press.

## **Appendix: A Density Iteration Process for Low-Cost/Low-Density Powered PST-TVFC Models**

Three technologies may be employed to power TVFC scaled models: small jet engines, pulsed jets or ducted fans driven by fast-rotating piston engines.

To satisfy eq. 11 one may use the small jet-engine option and construct a geometrically similar model with an average density approximately equals that of the aircraft and fly it at sea level, or a given altitude, to emulate the performance of the fullscale aircraft at the same altitude and under the same SACOM and other prerequisites enumerated by eq. 1.

Provided all eq.-1 requirements are met, this option represents the most accurate method to emulate or predict full-scale performance of TVFC aircraft. However, it may be prohibitive from cost, time, safety and other considerations, such as the unavailability of low-distortion vectoring PST inlets that would prevent jet-engine-out situations in the middle of a fast deep-PST maneuver.

Alternatively, one may use the low-cost, pulsed or ducted fans options and construct low-density models that emulate or predict aircraft performance at sea level by conducting SACOMs at high altitudes [i.e., at low air densities, as dictated by 11]. Since this option may not be cost-effective, a Density-Iterative-Process [DIP] may be employed.

DIP is based on the simultaneous use of model flight data and iterations generated by computer simulations of PST-TVFC-agility, whose inputs are the same SACOM-commands, model dimensions, IFPC-flyer delay times and recorded initial level speed as in the actual model flight. Computer simulation inputs include actually measured, model jet deflections, moment arm lengths, thrust components, vehicles average density ratio, moments-of-inertia, lift, drag, moment, force and coupling coefficients model data for conventional and PST flight conditions. The 'results' of this simulation are first compared with actual model flight data and then reused with the same SACOM and initial speed but with larger, ['ideal'] mass and moments-of-inertia

values, which conform with eqs. 4, 11 and 9, to obtain 'DIP-adjust' simulated data for high-average-density model emulation of PST-TVC-agility. Multiplying actual model flight data by the resulting DIP ratio [of high to low density models], and using eqs. 6 to 10, one can estimate expected maximum fullscale performance. For instance, when powered models with, say,  $\bar{\rho}_A/\bar{\rho}_M = 3$  are employed, the resulting low weight of the models allows the use of simple ducted fans at sea level to emulate or predict aircraft performance at this or higher altitudes, depending on the value of  $\rho_{aM}/\rho_{aA}$  dictated by eq.11. Speed transformation is then extracted from eq. 7.

Combined with the DIP-methodology, the emulation or prediction of fullscale performance by 'low-density' PST-TVC models appears to be more productive and cost-effective than the use of windtunnell or unpowered/unvectored free or drop models.

## **Program Manager, Participants & Personnel**

### **USAF Program Manager**

**Dr. W. Caleresa**, Chief of Aeronautical Engineering, USAF, AFOSR, EOARD, UK for the USAF-AFOSR-EOARD special project on constructing and flying a **vectored F-22** prototype, 1991-1992.

### **French Army & USAF Participants**

**Daniel Baumann** [USAF Capt., Flight Test Manager of the F-15 USAF STOL Maneuver Technology Demonstrator Program. M.Sc. Aero-Eng. & civil pilot. USAF-WOE visitor to the Jet Lab in 1991 and 1992. Theory, pre and post-flight analysis and calibration tests.]

**Klings Claude** [Participant from the French Army. Aero Eng.]

### **Jet Lab Personnel**

**Dr. Gal-Or, Ben** [Principal investigator & Head, JPL. Professor, Faculty of Aerospace]

**Dr. Sherbaum, Valery** [ Aero-Engines Eng., Deputy Head of Jet Lab. 'Fullscale' jet-engine tests, F-15 and F-22 vectoring-nozzle tests & computing work. Upgrading all Post-flight-analysis and calibrations. Post-stall vectorable inlet work].

**Dr. Lichtsinder, Michael** [ Computer simulations of post-stall vectored maneuvers. Control theory, gyroscopic calculations, accelerometers, noise filters design & calibration. Formely Assoc. Prof. in the USSR. ]

**Smolyar Solomom** [Worked on the MIG 29 Flight Control, Navigation and Avionics as well as on its jet-engine control. Aero-Electrical Eng. Just Arrived from the former USSR and joined the project to design auto-control yaw-vectoring loops for the next tailless flying prototypes.]

**Dr. Tal, Reuven** [Aero-Control Eng., Flight control, propulsion and signatures consultant]

**Dr. Rakotch, Efraim** [Mathematician, Solution of partial differential equations].

**Dr. Rasputnis, Alexander** [Aero-Engine Eng., Full-scale vectoring nozzle calibrations & tests & computing procedures. Recently retired].

**Mashiach Eliaho** [Aero-Engines Tech., Coordinator of all construction, instrumentation and mechanical work conducted at the Jet Lab. Construction of vectored F-15, F-16 and F-22 prototypes. Vectored Nozzles tests with 'full-scale' jet engines. F-15 subscale and 'fullscale' inlet work. Lab Safety Officer].

**Dekel Eliezer** [Aero-Engines Tech., Authorized Jet-Engine Operator. Mechanical and instrumentation work. Construction of vectored F-15, F-16 and F-22 prototypes. Vectored Nozzles tests with 'full-scale' jet engines. F-15 subscale and fullscale inlet/nozzle work.]

**Lisnyansky, Faina** [Senior Gas-Turbine/Jet-Engine Eng., Computer calculations and chart generation of jet-engine tests/calibrations and post-flight analysis.]

**Voroveichik Sara** [Mechanical Eng., Mechanical calculations & Drawing].

**Soreq Ilana** [JPL Secretary. Administration of contracts].

**Cruptnikoff Diego** [New notebook computer adaptation to modified, 3rd-generation, onboard flight recording computer, software modification for advanced/rapid post-flight analysis/display. Elect. Eng. ]

## Present & Past Flyers

**Turgeman Mike** [A leading flyer in Israel. Our 1st-rank flyer. Also constructor and flyer of our 1st roll-yaw-pitch, semi-tailless, pure thrust-vectoring RPV in 1987 and of the vectored F-15, F-16 and F-22 prototypes during 90-92. B.Sc & M.Sc. in Aero-Eng.]

**Friedman Erez** [Constructor and flyer of roll-yaw-pitch, semi-tailless, pure thrust-vectoring RPVs and vectored F-15 & F-16 RPVs till March 1990. B.Sc Aero Eng.]

**Baran, Shlomo** [Best-paid flyer of unmanned vehicles in Israel. Flies also IAI RPVs & new Unmanned Helicopter. Our flyer of vectored F-15 RPVs during Nov.-Dec 90. The contracted constructor of the F-22 prototype, with no propulsion system].

**Amir Yogev** [IDF authorized, "Day/Night/Operational" Military RPV Flyer. Our Flyer of vectored F-15 & F-16 RPVs from March 1990 to July 1990].

### **Pilots Within An Academic Course, Etc.**

**Berkovitch Raphi** [IDF Lt. Colonel & F-16 Pilot. Design & construction of elevator-less/rudderless [Semi-tailless], Yaw-Pitch-Roll , Thrust-Vectored F-16 RPV which made its first flight test on May 9, 91. A student within "Engine Design Course"].

**Sapir Shaul** [IDF Major & 707 pilot. Design, construction, and lab tests of the 4th-generation, elevator-less/rudderless [Semi-tailless], yaw-pitch-roll F-15 RPV which has not yet been flight tested. A student within "Engine Design Course" ].

**Gal-Or Amir** [IDF Capt., pilot. Participated in the conceptual design and the reviews of all flight test results]

**Gal-Or Gillad** [IDF Capt., pilot. Participated in the conceptual design and the reviews of all flight test results]

### **Subcontractors**

**From The PCSI Company: Pesach Pascal and Doron Rozenwaser** [A computer laboratory which, as a 'subcontractor', designed, manufactured and upgraded our three types of onboard and ground computers so as to fit with our different probes and contract changing needs].

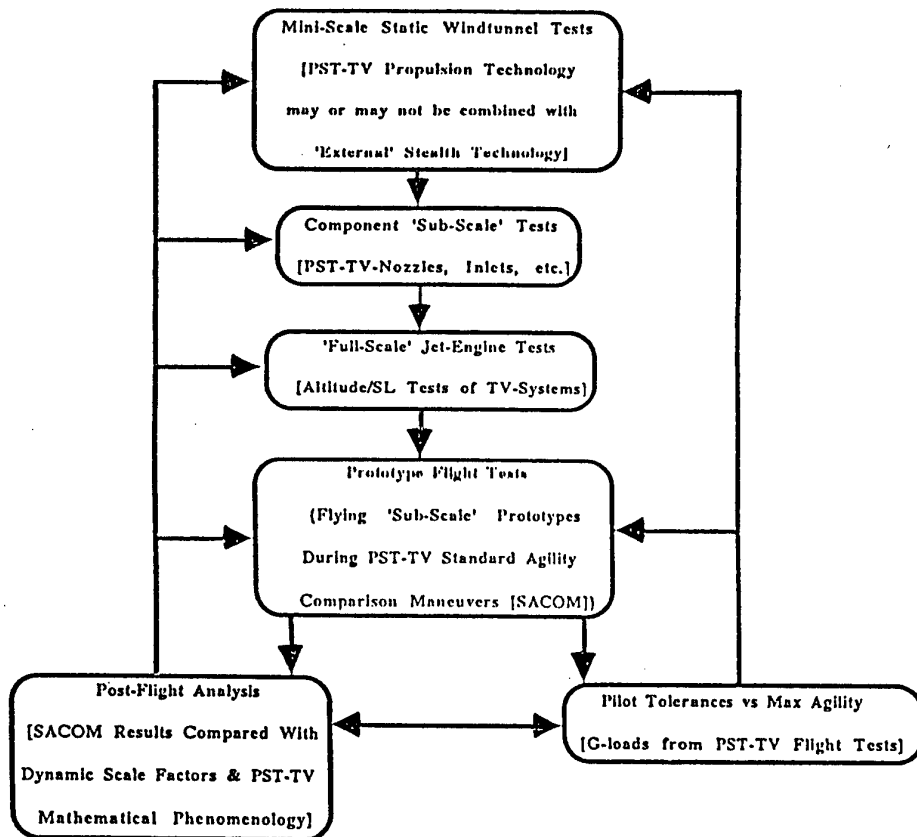
**From B. Engineering: Baruch A.** [Aero Eng. & Computer Eng. A subcontractor for computer simulations]

### **Previous USAF Program Managers**

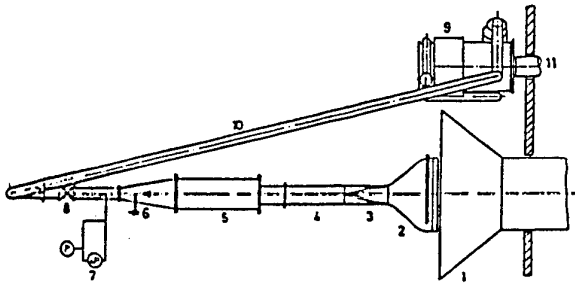
(i) - **D. Bowers**, from the FDD, WPAFB for the USAF/AFOSR/EOARD Grant Number AFOSR 89-0445 from April 1, 1989 to June 30, 1991 "**Vectored F-15**".

(ii) - **Maj. Dr. J. Wigle**, AFOSR-EOARD, UK, for the USAF/AFOSR/EOARD Special Project SPC-91-4003 [EOARD] from Aug. 1 to Sep. 30, 91. "**Vectored F-15**".

(iii) - **Dr. , D. W. Reppreger** from AL/WPAFB and **Col. J. Tedor**, Deputy Director, Human Systems, BAFB for the USAF/AL-WPAFB and Human Systems Division, BAFB, Special Project SPC-91-4003 [via EOARD]. "**Vectored F-15**".

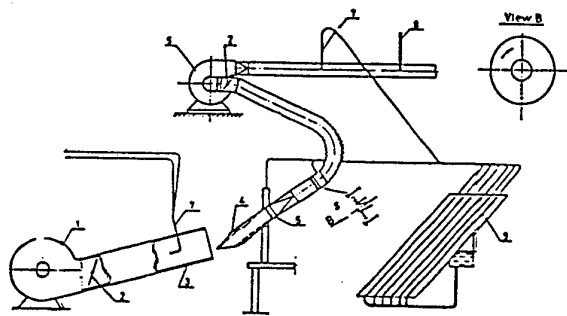


*Fig. 1:* The methodology developed by this laboratory



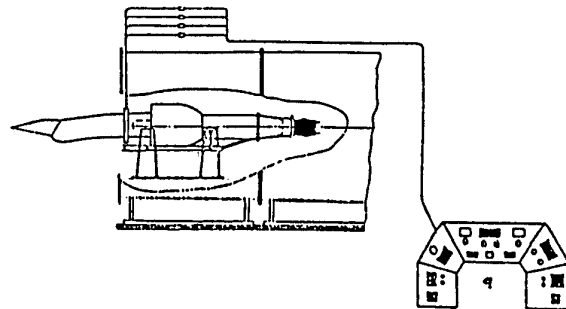
**Fig. 2: Component 'Sub-Scale' System For Testing Vectoring Nozzles**

1-exhaust; 2- TV-nozzle; 3,4 - transition/cooling sections; 4- PST-inlet contains rotatable pressure probes [view B]; 5- T-56 combustor; 6-fuel injector; 7-flow monitoring; 8-flow-control valve; 9-high-pressure gas turbine; 10-connecting pipe; 11-exhaust.



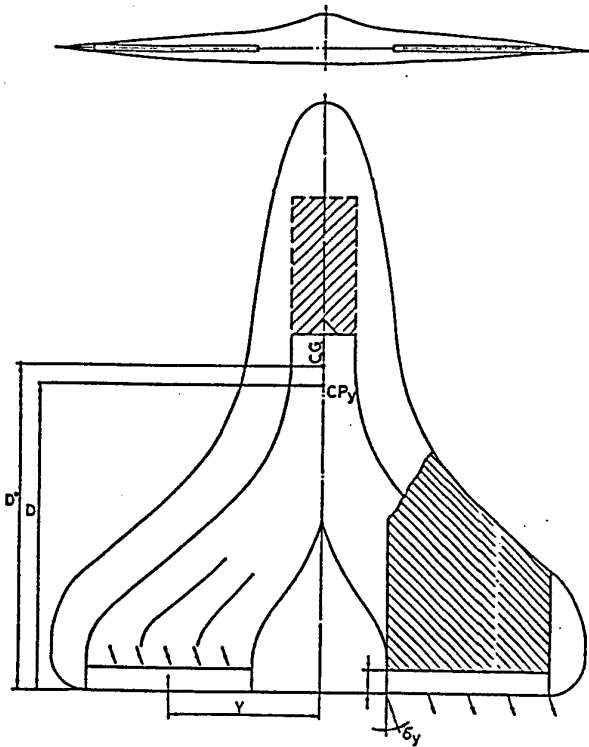
**Fig. 3: Component 'Sub-Scale' System for Testing PST-Inlets**

1-blowing fan; 2- airflow control; 3- duct; 4- PST-inlet with rotatable pressure probes [view B]; 5-AoA control mechanism; 6- suction fan simulates engine suction; 7- uniformities monitors; 8-Air temp.; 9- multiple-tube manometers.



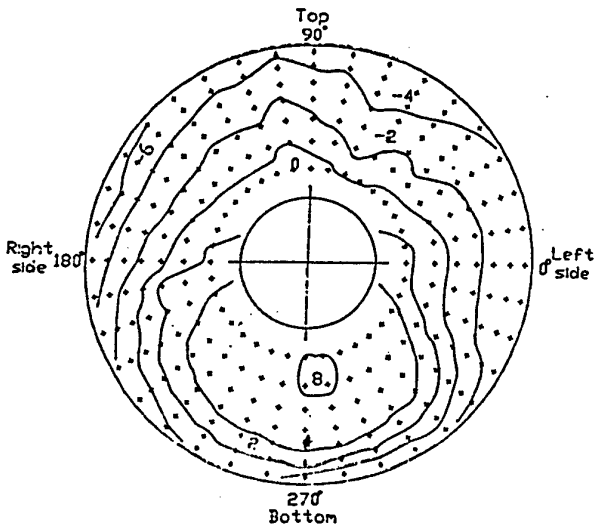
**Fig. 4: The 'full-scale' altitude jet-engine test facility**

1,2,3- engine sectors allow yaw-pitch nozzles for PST-TV F-15, F-16 and F-22 fighter aircraft to operate with vectorable inlets. 4,5,6- evacuation facilities. 7-fuel systems. 8-heat exchanger. 9-control room.

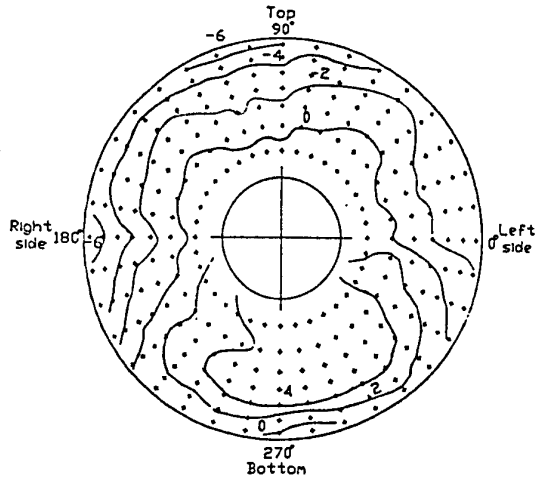


**Fig. 5:** The first family of flying roll-yaw-pitch PST-TV prototypes.

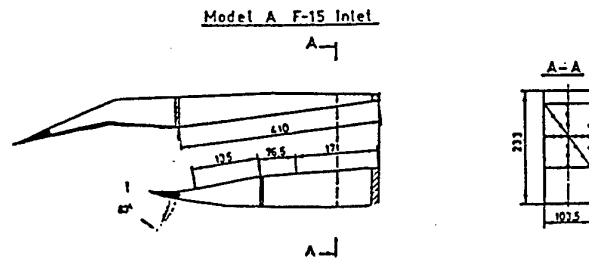
Shaded area represents super-circulation-affected wing section.



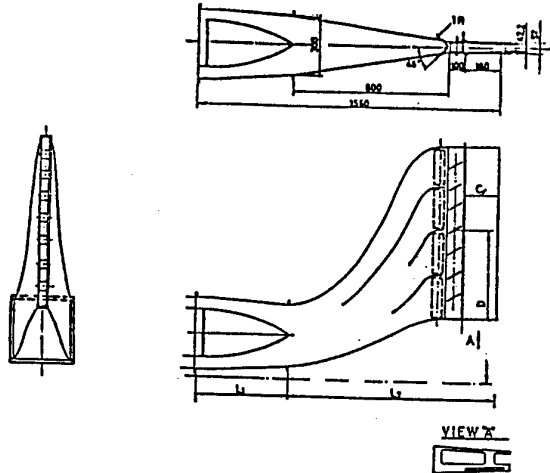
**Fig. 6:** Distortion generated inside inlets equipped with unvectored lips at 75 degrees AoA [1/7-scale, modified F-15 inlet; LDC units;  $M=0.14$ ;  $Re=10^5$ ].



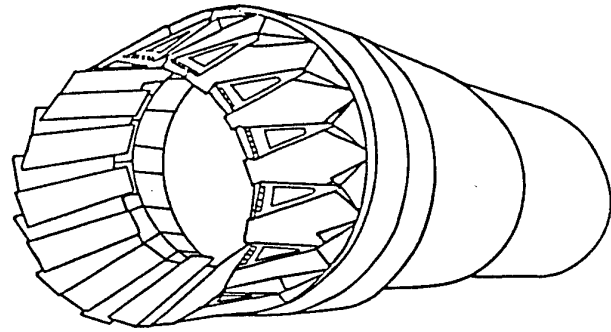
**Fig. 7:** 50% reduction in distortion is demonstrated with inlet-lip rotated towards the incoming airflow [75 deg. AoA, Cf. Fig. 8].



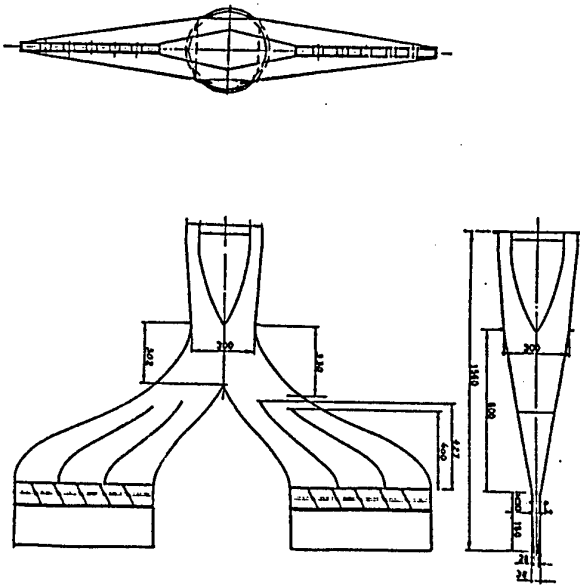
**Fig. 8:** The 'vectorable lip' is rotatable to 83 degrees towards the incoming airflow [cf. Fig. 7].



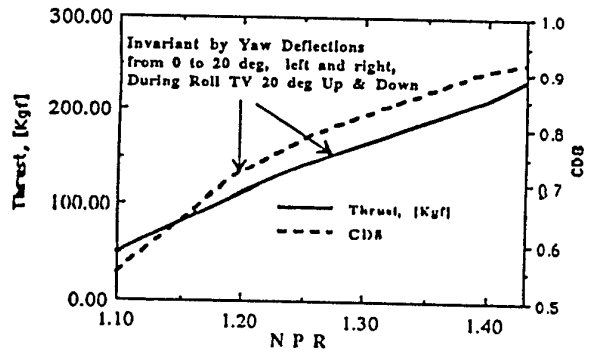
**Fig. 9:** A novel roll-yaw-pitch PST-TV-nozzle. [Aspect Ratio=20; View "A" shows sidewindows for yaw jet deflections and a simple sliding-pin mechanism for pitch TV.]



**Fig. 11:** Axi TV-nozzles are characterized by low flight-control rates.



**Fig. 10:** A novel roll-yaw-pitch PST-TV-nozzle. [Aspect Ratio=40].



**Fig. 12:**  $C_{D/R}$  and thrust reductions during yaw-TV-deflections are minimized with high-aspect-ratio nozzles.

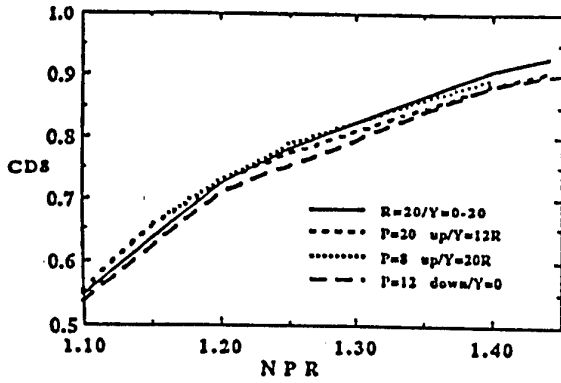


Fig. 13: Reduction in  $C_{D8}$  during TV-deflections in pitch, yaw and roll coordinates.

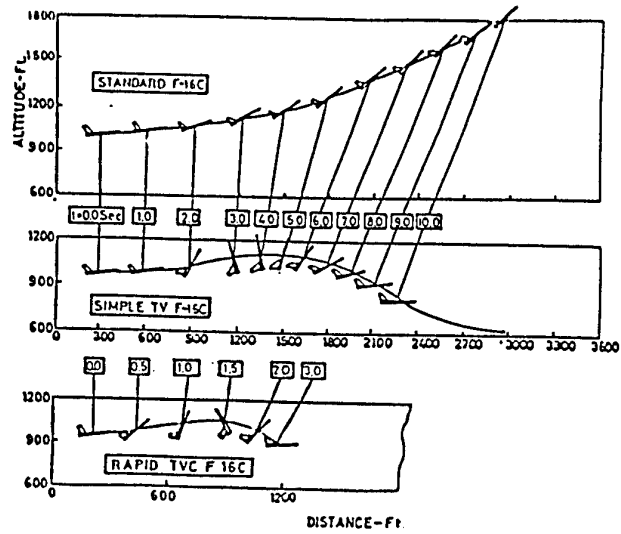


Fig. 15: Rule 1: Maximum jet-vectoring rates should equal conventional deflection rates.

Upper figure: Conventional turning rate at maximum pilot tolerance and restricted maximum AoA.

Lower figure: At low speeds, the faster the maneuver, the safer it becomes for a pilot located near the center of rotation. Mid-figure: Slow PST-TV-induced turning rate is less combat effective.

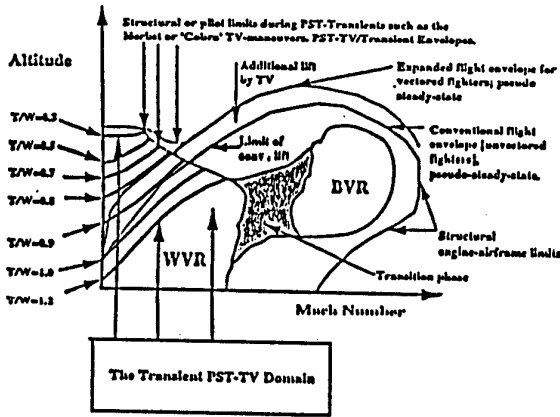


Fig. 14: The domain of PST-TV flight control.

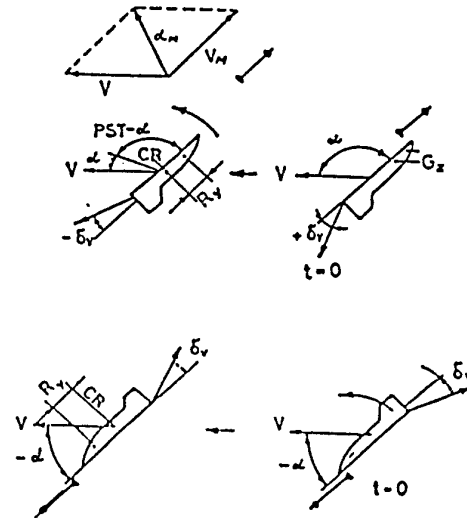


Fig. 16: Rule 2: Maximization of TV-moments and rates at the reversal point of positive and negative 'Cobra' maneuvers. [Note dangerous interactions with high-AoA launched missiles.  $V_M$  = missile's initial velocity vector whose magnitude increases with launch-rail length.]

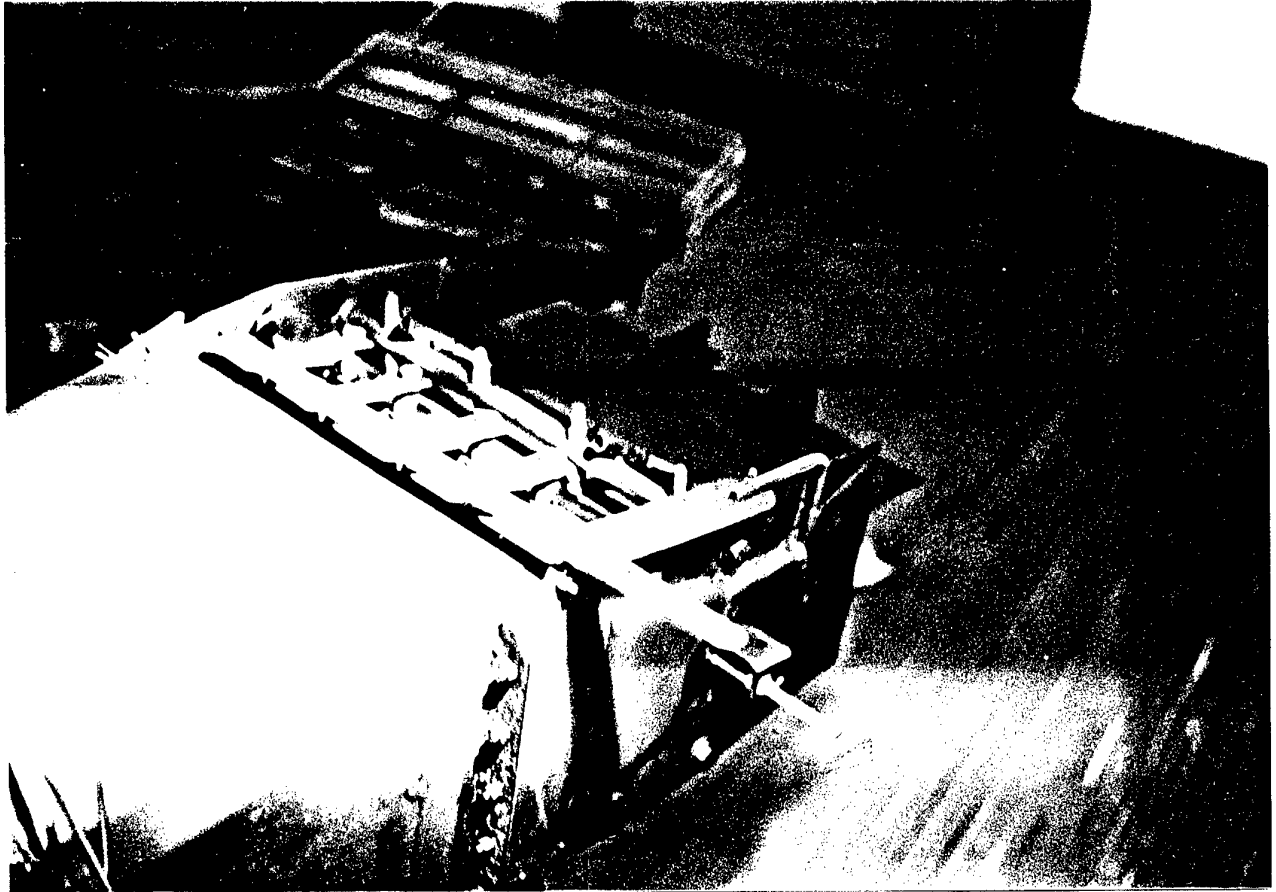


Fig. 17

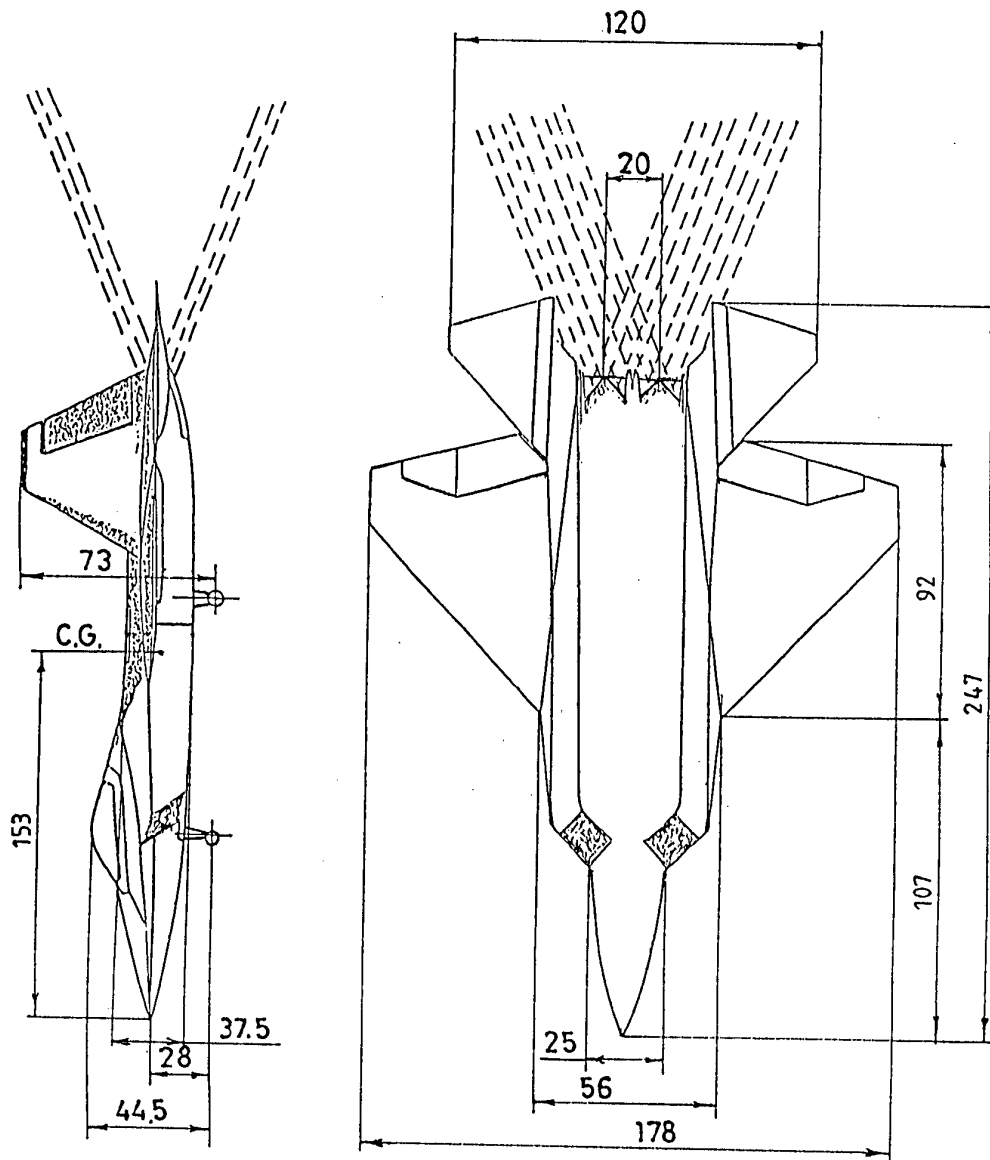


Fig. 18

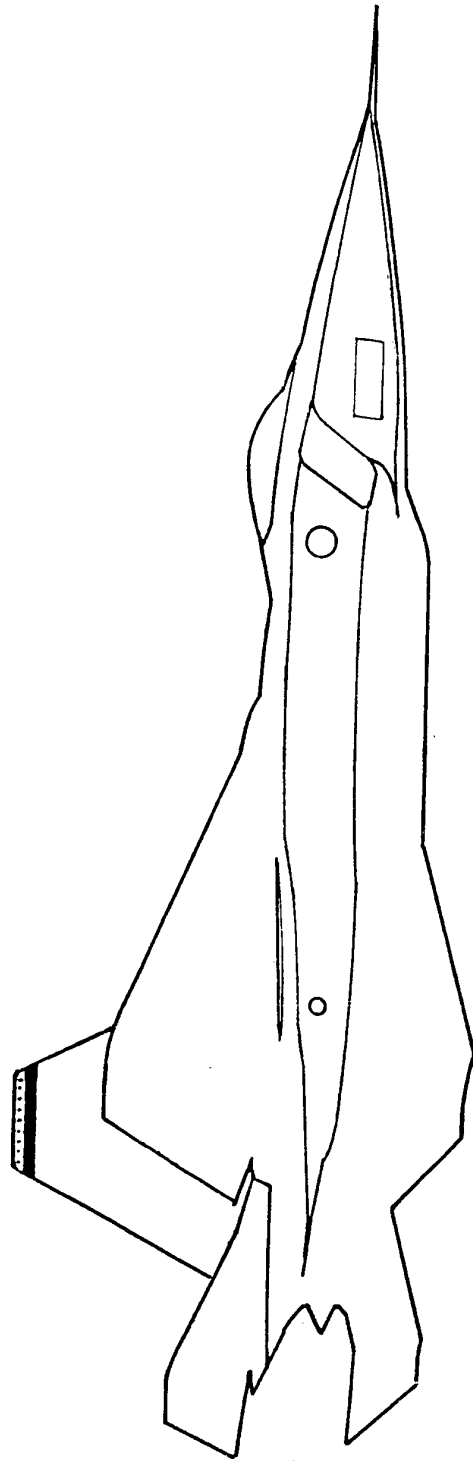


Fig. 19