



**US Army Corps  
of Engineers**  
Waterways Experiment  
Station

# Development and Evaluation of a Prototype Turbidity Sensor for In Situ, Long-Term Measurements

by *Linda S. Lillycrop, Gary L. Howell, Thomas E. White*

19961118 175

RECEIVED  
SEP 20 1996  
CERC  
WATERWAYS EXPERIMENT STATION  
VICKSBURG, MISSISSIPPI

Approved For Public Release; Distribution Is Unlimited

**DTIC QUALITY INSPECTED 1**

Technical Report CERC-96-9  
September 1996

# **Development and Evaluation of a Prototype Turbidity Sensor for In Situ, Long-Term Measurements**

by Linda S. Lillycrop, Gary L. Howell, Thomas E. White

U.S. Army Corps of Engineers  
Waterways Experiment Station  
3909 Halls Ferry Road  
Vicksburg, MS 39180-6199

**Final report**

**Approved for public release; distribution is unlimited**

Prepared for **U.S. Army Corps of Engineers**  
**Washington, DC 20314-1000**



**US Army Corps  
of Engineers**  
Waterways Experiment  
Station

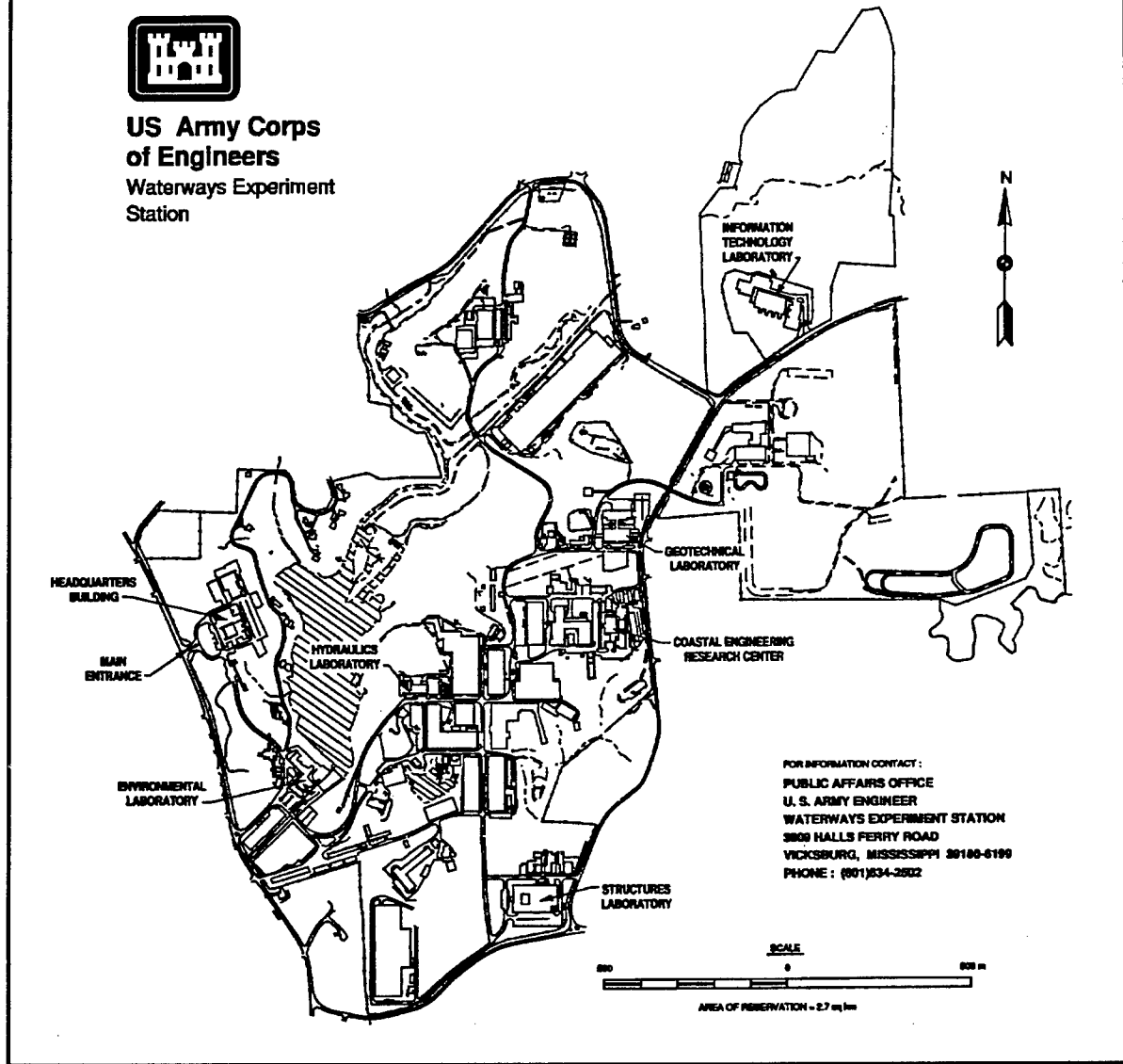

### Waterways Experiment Station Cataloging-in-Publication Data

Lillycrop, Linda S.

Development and evaluation of a prototype turbidity sensor for in situ, long-term measurements / by Linda S. Lillycrop, Gary L. Howell, Thomas E. White ; prepared for U.S. Army Corps of Engineers.

58 p. : ill. ; 28 cm. — (Technical report ; CERC-96-9)

Includes bibliographic references.

1. Turbidity — Measurement. 2. Sedimentation and deposition — Measurement. 3. Sediment transport — Measurement. I. Howell, G. L. (Gary Lanier) II. White, Thomas E. III. United States. Army. Corps of Engineers. IV. U.S. Army Engineer Waterways Experiment Station. V. Coastal Engineering Research Center (U.S. Army Engineer Waterways Experiment Station) VI. Title. VII. Series: Technical report (U.S. Army Engineer Waterways Experiment Station) ; CERC-96-9. TA7 W34 no.CERC-96-9

# Contents

---

Preface .....	vi
1—Introduction .....	1
Background and Need .....	1
Objectives .....	3
2—Turbidity .....	4
Definition .....	4
Types of Turbidity Data .....	6
Turbidity Measurement Technology .....	6
Turbidity Standards and Units .....	8
Turbidity Limits and Background Turbidity Levels .....	10
3—Optical Properties of Light Transmission Through the Ocean .....	15
Light .....	15
Inherent Optical Properties of the Sea .....	16
Transmittance .....	17
Absorption .....	19
Scattering .....	20
Effect of Particle Size and Wavelength .....	20
Effects of Other Variables .....	22
4—Prototype Sensor Conceptual Design .....	24
Prototype Sensor Considerations .....	24
Biological Fouling .....	25
Conceptual Design .....	26
5—Transmissometer Design and Fabrication .....	28
6—Sensor Tests and Results .....	34
Sensor Calibration .....	34
Degradation of the System .....	36
7—Future Work .....	44
8—Summary .....	45

References . . . . .	48
----------------------	----

SF 298

## List of Tables

---

Table 1. Significant Figures for Turbidity Measurement . . . . .	10
Table 2. State Water Quality Turbidity Limits . . . . .	11
Table 3. Manual Turbidity Levels (NTU) During and After Beach Nourishment, Longboat Key, FL . . . . .	12
Table 4. Factors Controlling Absorption and Scattering of Light in Natural Waters . . . . .	17
Table 5. Formazin Solutions for Sensor Calibration . . . . .	35
Table 6. Correlation of Attenuation Coefficient and NTU . . . . .	36
Table 7. Correlation of Attenuation Coefficient and NTU, Light Fouling . . . . .	39
Table 8. Correlation of Attenuation Coefficient and NTU, Moderate Fouling . . . . .	43

## List of Figures

---

Figure 1. Schematic of Jackson Candle Turbidimeter . . . . .	7
Figure 2. Schematic of Beam Transmittance Meter . . . . .	8
Figure 3. Schematic of Nephelometer . . . . .	9
Figure 4. Electromagnetic Spectrum . . . . .	16
Figure 5. Light Transmission Through a Sample Fluid . . . . .	18
Figure 6. Interaction of Light Beam with Particulate Matter . . . . .	19
Figure 7. Scattering by Particles of Varying Size . . . . .	21
Figure 8. Angular Patterns of Scatterance Distribution: (a) Small Particles, (b) Large Particles, and (c) Larger Particles . . . . .	22
Figure 9. Conceptual Design of Turbidity Monitoring System . . . . .	26

Figure 10. Turbidity Monitoring System Mounting Pod . . . . .	27
Figure 11. Schematic of Beam Transmissometer . . . . .	28
Figure 12. Transmissometer: (a) PVC-Pipe Housing, and (b) Schematic of Interior Sensor . . . . .	30
Figure 13. Sampling Cell Configurations: (a) Glass Cylindrical Sampling Cell Positioned Vertically, (b) Glass Cylindrical Sampling Cell Positioned Horizontally, and (c) T-Shaped PVC Pipe Sampling Cell Positioned Horizontally . . . . .	31
Figure 14. Schematic of Transmissometer Circuit . . . . .	32
Figure 15. Beam Intensities ( $V_a$ ) Versus NTU Corresponding to $V_r$ Settings of 0.08, 0.12, 0.15, 0.20, 0.25, 0.30, 0.32, 0.34, and 0.35 Volts . . . . .	37
Figure 16. Attenuation Coefficient ( $c$ ) Versus NTU Corresponding to $V_r$ Settings of 0.08, 0.12, 0.15, 0.20, 0.25, 0.30, 0.32, 0.34, and 0.35 Volts . . . . .	38
Figure 17. Attenuation Coefficient ( $c$ ) (Light Fouling) Versus NTU Corresponding to $V_r$ Settings of 0.08, 0.12, 0.15, 0.20, 0.25, 0.30, 0.32, 0.34, and 0.35 Volts . . . . .	40
Figure 18. Attenuation Coefficient ( $c$ ) (Moderate Fouling) Versus NTU Corresponding to $V_r$ Settings of 0.08, 0.12, 0.15, 0.20, 0.25, 0.30, 0.32, 0.34, and 0.35 Volts . . . . .	41
Figure 19. Comparison of Linear Regression Curves Corresponding to Attenuation Versus NTU in Cases with No Fouling, Light Fouling, and Moderate Fouling . . . . .	42

# Preface

---

This study was performed in accordance with the requirements of the Coastal Engineering Education Program (CEEP), which is part of the Corps of Engineers Long-term Training Program. This one-year program is offered through the U.S. Army Engineer Waterways Experiment Station (WES) Graduate Institute, the WES Coastal Engineering Research Center (CERC), and Texas A&M University (TAMU).

This study was conducted by Ms. Linda S. Lillycrop, Prototype Measurement and Analysis Branch (PMAB), CERC, in partial fulfillment of the requirements for the Master of Engineering degree, Ocean Engineering, from TAMU. Work was performed under the direct supervision of Mr. Gary L. Howell, Engineering Development Division, CERC; Dr. Thomas E. White, Visiting Assistant Professor, TAMU, and PMAB, CERC; Dr. Robert E. Randall, Associate Professor, TAMU; and Dr. Martin C. Miller, Visiting Assistant Professor, TAMU, and Chief, Coastal Oceanography Branch, CERC. General administrative supervision was provided by Dr. James R. Houston, Director, CERC, and Mr. Charles C. Calhoun, Jr., Assistant Director, CERC. The assistance of Messrs. Troy D. Nelson, Ralph E. Ankeny, and Jody P. Landreneau, PMAB, CERC, in fabricating project instrumentation is deeply appreciated.

At the time of preparation of this report, Dr. Robert W. Whalin was WES Director and COL Bruce K. Howard, EN, was WES Commander.

*The contents of this report are not to be used for advertising, publication, or promotional purposes. Citation of trade names does not constitute an official endorsement or approval of the use of such commercial products.*

# 1 Introduction

---

Concern over the environmental effects resulting from the US Army Corps of Engineers (USACE) coastal operations, such as navigation channel dredging and beach nourishment projects, has created the need to accurately measure and predict variations in nearshore environmental conditions. Variations in environmental conditions result from USACE activities as well as seasonal changes and meteorological events. Turbidity has become a focal point of these environmental concerns. Technology is only available for short-term turbidity measurements, which are often collected during USACE coastal operations. These sporadic measurements are of limited value in determining long-term effects and turbidity ranges necessary to evaluate the possible impacts of a coastal project. Our present knowledge is minimal in correlating the changes in turbidity as a function of coastal hydrodynamics. In situ, long-term turbidity measurements encompassing seasonal trends and meteorological events are necessary to quantify temporal variations in turbidity as a function of coastal processes.

## Background and Need

State and Federal regulations require the USACE to mitigate adverse environmental impacts resulting from coastal operations. Specifically, the USACE must 1) apply methods to minimize turbidity levels or prevent them from exceeding regulated levels, such as turbidity curtains in dredging operations, or 2) repair or replace impacted areas, such as wetlands or sea grass beds, if damage occurs. Although the above options are available, difficulty remains in quantifying turbidity levels which result in adverse impacts to the environment. There are little or no data available to determine "natural" turbidity ranges, identify when they are exceeded at a given location, and determine the duration of high turbidity levels when they occur. The problem is compounded during storm conditions when measurement of maximum turbidity levels are difficult and long-duration measurements are inhibited.

Technology for measuring turbidity in the coastal zone is currently available; however, existing sensors are limited to short-term deployment mainly due to biological fouling of instrumentation and/or limited life of system

components such as bulbs, batteries, memory storage, and the overall power consumption of the system. Biological fouling of instrumentation caused by the saltwater environment reduces the ability to extract accurate, repeatable turbidity measurements from a sample, and performance of the system degrades until the system is inoperable. Short-term measurements do not reflect the naturally occurring turbidity variations resulting from meteorological forcing and seasonal trends. Therefore, an evaluation of deviations from naturally occurring turbidity levels due to USACE coastal operations is extremely difficult due to the lack of available long-term data from a variety of project conditions.

Turbidity measurement methodologies are complicated by the different or confused definitions of turbidity used by the various fields of science and engineering. The complexity of the problem is compounded by the environmental protection standards for the assessment of environmental impacts of design, construction, and operation of coastal projects. The present measurement methodologies and existing water quality standards are applicable in the laboratory environment; however, their applicability to the field environment is inappropriate due to the multitude of factors influencing turbidity in natural waters. Although instruments which use various methodologies for turbidity measurement are available, only absorptometers/transmissometers can provide continuous, long-term, in situ measurements while meeting the criteria for survival in the ocean environment. However, absorptometers/transmissometers provide measurements of beam transmittance and do not provide output in Nephelometric Turbidity Units (NTU), the legally acceptable units specified by water quality standards. A universal turbidity measurement standard relative to light attenuation for environmental protection should be developed to relate field measurements of water quality to light-dependent phenomena (McCarthy, Pyle, and Griffin 1974).

Short-term turbidity measurements are currently collected throughout USACE coastal projects in an effort to evaluate impacts the project may have on the environment. Dredging and dredge material disposal from operations can cause a severe problem with respect to excessive turbidity in the surrounding waters. Material is released and carried away from the project site by tides and currents resulting in increased turbidity within a region (Wilber 1983). Turbidity sampling is conducted prior to and during dredging operations to evaluate the level of increased turbidity caused by the dredging operation. Upon completion of dredge disposal operations, turbidity measurements are taken sporadically to evaluate leakage from contained disposal sites. The sporadic, short-term measurements do not provide sufficient information to determine leakage rates and possible environmental impacts.

Another need for measuring long-term turbidity is to support remote sensing technology. The success or failure of projects which involve remote sensing may be dependent on water clarity or its transparency. Water clarity for remote sensing is typically measured using a Secchi disk, an eight to twelve inch in diameter disk segmented in black and white sections. The disk is lowered by an observer on a vessel, and the depth at which the disk disap-

pears is a measure of the water clarity (Williams 1970). In most instances, it is impossible or not economically feasible to make frequent measurements of optical properties at a location (Wilber 1983). Data detailing the impact of seasonal trends and meteorological effects would reduce time and costs to determine if remote sensing capabilities are feasible at a site.

Development of an in situ, long-term turbidity sensor will provide the ability to collect turbidity measurements over durations ranging from one month to one year. Turbidity measurements may be correlated with approved water quality standards to allow evaluation of turbidity levels. For the first time, natural background levels of turbidity resulting from coastal hydrodynamics and seasonal trends can be established from long-term measurements. These background levels will provide data which can be compared with turbidity measurements collected during USACE coastal operations, such as navigation channel dredging and beach nourishment projects, to determine the turbidity changes resulting from the operations.

## **Objectives**

The study objectives are 1) define the measurement of turbidity required to evaluate nearshore environmental effects which result from USACE coastal operations; 2) investigate the present capabilities in turbidity measurement and relate them to the USACE need; 3) develop theoretical principles required for sensor design and fabrication; 4) fabricate a prototype sensor; 5) perform laboratory tests for sensor design optimization; and 6) summarize study results. The result of the study is a calibrated prototype sensor which provides the design for development and long-term operation of a USACE turbidity measuring system.

## 2 Turbidity

---

The evolution of the study of turbidity is described by Berger (1974) stating "one can assume the first turbidity data were taken shortly after the expulsion from Eden. It probably consisted of a grunt from Adam when he discovered something in his water and threw it out. The first quantification of turbidity followed shortly thereafter when Eve found she could satisfy Adam's complaint by serving water from a jar that had been standing for a while and was less 'turbid.' For a long time the study of turbidity did not become any more exact than this."

### Definition

The concept of turbidity is optical; however, the use of the term "turbidity" is ambiguous (Austin et al. 1974). Turbidity, unfortunately, is not as precisely defined as pH, conductivity, temperature, or many other water quality parameters which are more familiar (Koeppen 1974). The physical meaning of turbidity varies with the field of science and engineering of interest (Wilber 1983). Turbidity definitions range from the qualitative such as the cloudiness of the fluid to a quantitative measure which characterizes the degree in which physical parameters affect the appearance of the medium. There is also great diversity and lack of correlation among the instrumental approaches and data applications in the measurement of turbidity (Austin et al. 1974). These varying definitions, measurement methods, and data applications have resulted in confusion in efforts to relate the "turbidity" of one medium to another, or to a standard scale.

As an example, four turbidity studies were conducted by various scientists using different optical measurements for different applications. Each stated they were measuring turbidity, but provided the following definitions of turbidity (Koeppen 1974): 1) the correlation of transmissometer measurements of certain bacterial cultures with the growth curves of the organisms (Institute for Microbiology and Experimental Therapy, Germany), 2) the correlation between transmissometer measurements and the presence of various kinds of plankton (Naval Electronics Laboratory, CA), 3) a nephelometer at a municipal water treatment plant monitoring the iron concentration in a city's water supply (Hach Chemical Company, CO), and 4) Tyndall Effects meter data

correlated to the suspended sediment concentration of river watersheds in Northeastern Vermont (U.S. Department of Agriculture). Other scientists define turbidity as 1) the optical property of a suspension with reference to the extent to which the penetration of light is inhibited by the presence of insoluble material (Rainwater and Thatcher 1960), (2) the reduction of transparency due to the presence of suspended particulate matter (Brown, Skougstad, and Fishman 1970), and (3) an unclear condition or cloudiness of water (Brown and Ritter 1971).

The term "turbidity" has no clear or precise meaning without further explanation as to the medium in which the measurements are made. The above definitions also indicate that turbidity may be defined by the instrument used or by the reason for measuring turbidity. Turbidity in water is caused by suspended matter such as clay, silt, finely divided organic and inorganic compounds, plankton, and other microscopic organisms. Turbidity is an expression of the optical property that causes light to be scattered and/or absorbed rather than transmitted in straight lines through a sample. Excessive turbidity reduces light penetration into the water and, therefore, reduces photosynthesis by phytoplankton organisms, attached algae, and submerged vegetation (FWPCA 1968). The measure of turbidity is often confused as a measure of the concentration of suspended sediment. A correlation of turbidity with weight concentration of suspended matter is difficult because the size, shape, and refractive index of the suspended particulate also affect the light-scattering properties of the suspension (Ridd and Larcombe 1994). Although turbidity is not synonymous with concentration of suspended sediment, the concepts are related in some instances. Turbidity can be used to help define the level of sediment concentration. The ratio of concentration to turbidity is higher when a considerable amount of sand is carried in suspension in comparison to an insignificant amount of sand carried in suspension. Since sand has a smaller surface area per unit weight than silt and clay, a sample containing mostly suspended silt and clay would be more turbid than a sample with equal weight of suspended sand (Ritter and Ott 1974).

Many methods exist for the determination of water contaminants; however, turbidity measurement is significant since it is a simple and undeniable indicator of water quality change. A sudden change in turbidity may indicate an additional source of pollution (biological, organic, or inorganic), or a change in a water treatment test (Hach, Vanous, and Heer 1990). The measurement of turbidity provides information about the esthetics of an estuary, stream, or lake; may pertain to biological conditions, and may be used to delineate water-quality standards for drinking water and water used by industry (Ritter and Ott 1974).

In order to quantify and qualify the turbidity measurement, the relationship between the light absorbing and light scattering properties of a suspension and the physical and chemical properties of the material in suspension must be established (Koeppen 1974). Perhaps Berger (1974) says it best: "Turbidity, whether considered in its myriad of specialized definitions to satisfy exacting

project requirements or in the general terms in which most people consider, it is the effect on light in water of things in the water."

## **Types of Turbidity Data**

Turbidity can be measured both qualitatively and quantitatively. Qualitative data are useful in describing the medium and providing an indication of degree of turbidity such as clear, cloudy, murky, muddy, or thick; however, quantitative data are necessary for communicating information about a medium, comparison of samples, use in calculations, and comparison and evaluation of a medium to environmental standards. Three types of data can be considered turbidity data: descriptive, instrument data, and photographic or remote sensing data (Berger 1974). The simplest and oldest means to evaluate turbidity is through descriptive data; however, the data are a qualitative observation and susceptible to the judgement of the observer. Photographs or remote sensing through satellite imagery or multi-spectral scanners used aboard aircraft provide detailed qualitative records of turbidity over variably sized areas. An evaluation of turbidity levels can be obtained through comparison of repeated observations collected at a site (Wilber 1983). However, quantitative information can not be obtained through photographs alone to ensure compliance with state and federal limits on turbidity levels. Instrument data provides quantitative temporal records of turbidity levels at specific locations. The data can be used in calculations, compared to other records, and related to turbidity standards. These quantitative measurements are used to determine whether the level of turbidity exceeds environmental limitations. A problem with instrument measurements is the inability to collect enough data (Austin 1974). Instrument data may be correlated with photographic data to obtain quantitative temporal and spatial distributions of turbidity levels for evaluation with environmental limits.

Turbidity can be separated into two classes: fresh water and salt water (Koeppen 1974). However, the salts present in sea water have no significant effect on absorption in the visible/photosynthetic light range (Kirk 1994). The two classes are further subdivided into in situ and non-in situ depending on whether the turbidity of the medium is measured in real-time or if samples are collected from the medium and the turbidity of the sample is measured later. Since turbidity characteristics are affected by suspended particulate matter and living organisms, real-time measurement is most accurate and preferred due to errors introduced by settling of suspended particulate matter and loss of perishable living organisms (Koeppen 1974).

## **Turbidity Measurement Technology**

Early attempts to quantify turbidity date to 1900. These attempts were based on the assumption that the principal cause of turbidity in municipal water supplies was the suspended silt in the water. Jackson devised an appa-

ratus, a simple extinction photometer, to indirectly indicate the quantity of silt present in the water. The apparatus, referred to as the Jackson Candle Turbidimeter (Figure 1), consists of a graduated cylinder supported on a stand which positions the cylinder above a candle flame. The medium for which turbidity is to be measured is slowly poured into the graduated cylinder until the image of the candle flame, viewed through the graduated cylinder, diffuses into the glow field. The height or distance of fluid required to diffuse the image is a measure of turbidity. The standard method of determination of turbidity has been based on the Jackson Candle turbidimeter (Austin 1974).

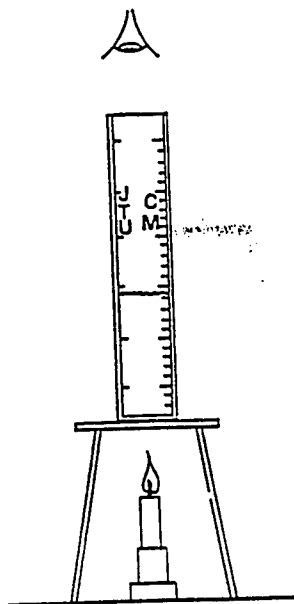

Figure 1. Schematic of Jackson Candle Turbidimeter (from Hetrick (1974))

Modern turbidimeters measure the turbidity of a medium through technology which measures 1) the transmission, or attenuation, of light which passes through a medium, 2) the scatterance of light from a narrow beam passing through a medium, or 3) a combination of transmitted and scattered light as a light beam propagates through a medium. The types of instruments which provide these measurements are beam transmittance meters and nephelometers. The theory of operation of modern turbidity meters is described in detail in Part III.

The beam transmittance meter, Figure 2, is designed to measure the attenuation coefficient,  $c$ . The principle of operation of the meter is to produce a collimated beam of light from a light source. The collimated light beam passes through a sample fluid of fixed path length. A detector, usually a photocell, is located a fixed distance ( $l$ ) from the light source and measures the amount of light which is transmitted through the sample fluid. An aperture positioned in front of the detector limits the angle of light which the detector may receive. Therefore, scattered light is prevented from reaching

the detector. The ratio of the emitted and transmitted light fluxes from the source and detector provide a measure of light transmittance, or attenuation, through the medium. The measure of light transmittance is an indication of turbidity level. A transmission ratio of 1, or 100% transmission, indicates that all the light emitted from the light source is transmitted through the medium, and the medium is therefore turbidity free. A decrease in transmitted light corresponds to an increase in turbidity level (Jerlov 1976).

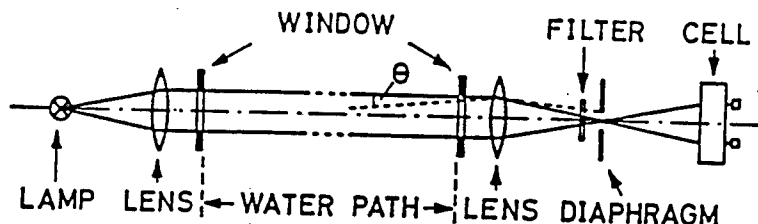

Figure 2. Schematic of Beam Transmittance Meter (from Jerlov (1976))

Nephelometers measure the scattering coefficient,  $b$ , through measurement of the light scattered out of a narrow beam passing through a fluid. The principle of operation is similar to that of a beam transmittance meter, however, the detector is located at an angle to the incident light beam. As shown in Figure 3, nephelometer detectors may be located at angles of 45, 90, and 135 deg to measure forward, 90-deg, and backward scatter, respectively (D&A Instruments 1989). A 90 deg detection angle is considered to be the least sensitive to variations in particle size, therefore, most nephelometers measure 90 deg scatter (Hach, Vanous, and Heer 1990).

Some modern turbidimeters combine the methodologies of transmissometers and nephelometers, and provide a measure of both the transmitted and scattered light. This technique is termed "Ratio" technology. Utilizing ratio techniques improve the linearity of measurements for high range turbidity levels (HF Scientific 1992).

## Turbidity Standards and Units

Documented standards for turbidity are published by The United States Environmental Protection Agency, USEPA, (Methods for Chemical Analysis of Water and Waste, 1971), The Department of Interior's Geological Survey, Office of Water Data Coordination (Recommended Methods for Water-Data Acquisition) and the American Public Health Association, APHA, (13th editions of Standard Methods for the Analysis of Water and Waste Water). All

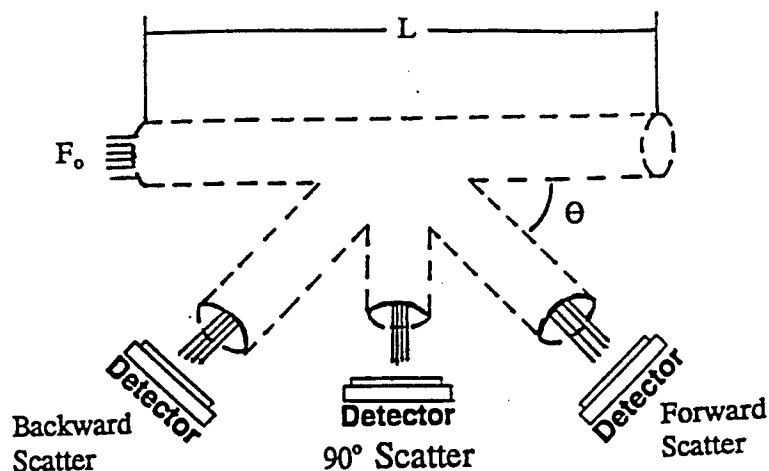

Figure 3. Schematic of nephelometer (after D&A Instruments (1989))

three groups specify nephelometric approaches for turbidity standards (Koeppen 1974). USEPA-approved turbidimeters use the following Nephelometric principles: 1) Tungsten filament lamp operated between 2200 and 2700 degrees K, and 2) Detection of light scattered at 90 deg from the incident beam (HF Scientific 1992).

In 1900, Jackson and Whipple developed a standard suspension of fluid using 1000 parts per million (ppm) of diatomaceous earth in distilled water. A ppm, silica scale for calibrating turbidimeters was developed by diluting the standard suspension to measured concentrations. Jackson then used the known concentrations of ppm suspended silica to calibrate the Jackson Candle Turbidimeter. The height of fluid for various suspended concentrations required to cause the image of the candle flame to be lost in the surrounding glow field due to the suspension corresponding to a measure of turbidity. This provided a relative scale of turbidity measurements in units of Jackson Turbidity Units (JTU's). Reproduction of the Jackson Candle Turbidimeter standards and results were difficult due to variability in naturally occurring concentration and size distributions in diatomaceous earth samples from different sources. In 1926, Kingsbury and Clark developed formazin as a new suspension standard. Formazin is prepared by accurately weighing and dissolving 5 g of hydrazine sulfate ( $N_2H_4 \cdot H_2SO_4$ ) and 50 g of hexamethylenetetramine in one liter of distilled water. The solution develops a white turbidity which can be prepared repeatedly with an accuracy of  $\pm 1\%$ . Formazin is a polymer suspension with particles of uniform size and shape. A stock formazin suspension will be 400 or 4000 Formazin Turbidity Units (FTUs) which can be diluted to any value using turbidity free water. The useful life of a formazin suspension is reduced as dilutions are prepared. Formazin is the approved primary reference standard for turbidity by the USEPA, APHA, and the American Water Works Association. In 1955, the

relationship of ppm silica concentration and turbidity was abandoned, and turbidity was redefined in terms of light scattering due to suspended matter and the adopted measurement unit became "Turbidity Units". When formazin was accepted as the primary reference standard, units of turbidity became FTUs (Hach, Vanous, and Heer 1990).

The Jackson Candle Turbidimeter, however, is cumbersome, dependent on human judgement, and cannot measure turbidity lower than 25 JTU. Additionally, the light source in the Jackson instrument, a candle flame, does not adequately produce light in wavelengths over the entire visible spectrum. Therefore, the instrument is not sensitive to fine particle suspensions. Transmissometers and nephelometers were then developed which use photoelectric detectors to measure absorption and scattering of transmitted light through a fixed volume of sample fluid. Instruments which use nephelometric methodologies, and measure scattered light, are calibrated with formazin but record turbidity in Nephelometric Turbidity Units (NTU) (Hach, Vanous, and Heer 1990).

To distinguish between turbidities derived from visual and nephelometric methods, results from a Jackson Candle Turbidimeter or other visual extinction methods are expressed in JTUs and results from nephelometric methods are expressed in NTUs. The USEPA (1979) states that JTUs, NTUs, and FTUs are all interchangeable units (Hach, Vanous, and Heer 1990). The USEPA recommends that the various ranges of turbidity levels be recorded with the corresponding significant digits as provided in Table 1.

<b>Table 1 Significant Figures for Turbidity Measurement</b>	
<b>NTU</b>	<b>Record to Nearest:</b>
0 - 1	0.05
1 - 10	0.1
10 - 40	1
40 - 100	5
100 - 400	10
400 - 1000	50
> 1000	100

## **Turbidity Limits and Background Turbidity Levels**

Federal Water Quality Standards (FWPCA 1968) recommend general turbidity level limitations as follows:

(1) Turbidity in the receiving waters due to the discharge of wastes should not exceed 50 JTU in warm-water streams or 10 JTU in cold-water systems.

(2) There should be no discharge to warm water lakes that would cause turbidities exceeding 25 JTU. The turbidity of cold-water or oligotrophic lakes should not exceed 10 JTU.

However, state water quality standards for turbidity limits differ from federal standards and vary among the states. Additionally, state documented limits are modified on a project by project basis depending on project circumstances. Information obtained to document state limitations also conflict among sources. For instance, the limiting turbidity level in Florida has been documented as a measurement not exceeding 29 NTU (Hanes 1994) and as a measurement not to exceed 29 NTU above the background turbidity level (personal communication Schmidt 1995). Most states use the NTU unit for turbidity measurement. However, Texas continues to use a measure of g/l sediment concentration to quantify turbidity (personal communication McLellan 1995) and California evaluates turbidity levels on a percentage of exceedence basis (personal communication Risko 1995). The general turbidity limits relative to exceedence units above background levels for various states are provided in Table 2.

<b>State</b>	<b>Level Above Background</b>
Alabama	50 NTU
California	20 %
Florida	29 NTU
Louisiana	50 NTU
Mississippi	50 NTU
Texas	8 g/l
Wisconsin	25 NTU

Some controversy remains in resolving whether these turbidity limits are valid due to the lack of accurate background turbidity levels. Obtaining accurate records of background turbidity levels is difficult since the measurements are usually collected manually and result in sporadic measurement schemes. Recorded background turbidity levels are inconsistent at a site due to the varying weather conditions, wave climate, and the inability to collect repeated measurements at a specified location. For instance, turbidity levels change with the amount of rain fall or wind duration at a site. Increased rain or wind increases turbidity. No established criteria exist such as allowing X amount of days with no rain prior to collection of background turbidity levels. Records of weather, wind, and wave conditions are not obtained which correspond to

background turbidity levels. Therefore, present records of background turbidity levels are not relative to anything. Background turbidity levels are also not collected during storm conditions. Therefore an evaluation of whether turbidity levels during coastal operations exceed natural-storm-condition turbidity levels can not be determined.

Various studies in which turbidity levels were collected prior to and during project implementation are summarized below. These summaries provide an indication of the difficulty in documenting background turbidity levels; however, they do provide an indication of the turbidity ranges at the project sites. The present methods for measuring turbidity for compliance with the current turbidity standards are inconsistent and inappropriate in determining construction impacts to the marine environment. These few examples justify the need for technology to provide long-term, in situ turbidity measurements for the determination of accurate background and project-construction turbidity levels.

A field study was conducted by Hanes to measure natural and man induced fluctuations of suspended sediment and turbidity in connection with beach nourishment on Longboat Key, FL (Hanes 1994). Manual turbidity measurements were obtained at hard bottom and control sites by SCUBA divers. Divers collected water samples near the surface, mid-depth, and near the bottom of the water column. The water samples were then sub-sampled on board the diving vessel, and turbidity measurements were obtained using an HF Scientific Model DRT-15C portable turbidimeter. Table 3 lists the average turbidity readings for the hard bottom and control sites during and after nourishment. Table 3 shows: 1) the mean turbidity at hard-bottom sites was larger than control sites during nourishment, 2) the mean turbidity at hard-bottom sites decreased after nourishment, and 3) turbidity at hard-bottom sites is less than control sites after nourishment.

	Level	Hard Bottom	Control
During Beach Nourishment	surface	4.6	2.9
	mid-depth	5.8	4.0
	bottom	7.5	5.5
After Beach Nourishment	surface	2.8	4.4
	mid-depth	3.2	5.5
	bottom	4.4	9.2

Overall, the average turbidity values are low relative to the 29 NTU standard. However, Hanes states that the values represent discrete readings and this sampling cannot be considered random. The manual turbidity levels were

collected only when weather permitted. During the monitoring period, turbidities did exceed 29 NTU at sporadic locations on three different days. Hanes concludes that the turbidity measurements were probably under-sampled and biased toward low wave conditions.

Turbidity was monitored during a truck-haul beach fill project near the City of Cape Canaveral. Turbidity measurements were obtained through use of an HF Scientific Model DRT-15C portable turbidimeter. Samples were collected twice daily (am and pm) at the surface and mid-depth. The collected samples were immediately analyzed on-site. Background turbidity levels ranged from 3 to 59 NTU, and turbidity levels during project construction ranged from 4.5 to 79 NTU. However, the turbidity levels during project construction only exceeded the 29 NTU exceedence limit above background on one occasion. The background level was 24 NTU, and the construction level was 54 NTU, resulting in 30 NTU above background level (written communication Bodge 1995).

The following observations were made relative to turbidity at the project site. The background turbidity of nearshore water near the City of Cape Canaveral is highly variable and is strongly a function of the wind speed and direction. During the majority of construction, the project was a negligible turbidity source, and its effects were not detectable by visual observation. Exceptions occurred when wind and wave energy were low. Under these conditions, turbidity was induced near high tide when the water level reached the toe of the fill and entrained particles. The particles were not significantly dispersed due to the lack of turbulence and transport. There was a greater variance between background and construction turbidity levels during high tide, and differences between turbidity levels at the surface and mid-depth were negligible (written communication Bodge 1995).

In a beach nourishment project on Fisher Island, FL, typical background turbidity levels ranged from 2 to 20 NTU, and turbidity levels measured throughout nourishment ranged from 6 to 30 NTU. At nearshore disposal operations near Port Canaveral, FL, measured background turbidity levels ranged from 0 to 50 NTU, and during disposal operations turbidity levels ranged from 0 to 65 NTU. These manual measurements were collected sporadically and only when weather permitted (written communication Bodge 1995).

Maintenance dredging of Santa Barbara Harbor has been performed since 1972 to ensure safe navigation in the harbor and navigation channel and to provide beach nourishment to eroded downcurrent beaches. An environmental monitoring program was developed to determine what effect beach disposal of dredged material may have on the success of grunion spawning. The California grunion provide an important sport fishery due to their unique spawning behavior. Turbidity was monitored in a control zone as well as within the harbor and adjacent beaches. Turbidity levels in the dredging and disposal areas ranged from 3.2 to 89.8 NTU during operations and decreased to a range of 1.85 to 29.3 NTU after dredging operations. No direct correlations

were discovered between observations of spawning grunion and any of the chemical and physical factors recorded. The lack of direct correlation between these factors and observations of spawning grunion may be an artifact of insufficient sample size or number of data sets (Buckley and O'Neil 1994).

A hydraulic pipeline dredging operation was recently completed at Ocean-side Harbor, CA. Turbidity monitoring was conducted in the harbor and at the disposal site. Measurements were collected at the two locations both prior to and during the dredging operation. Turbidity levels were collected through Secchi disk measurements. Base line Secchi disk data were collected on one day. Statistical calculations based on Secchi disk depths were used to determine whether the dredging operation should be shut down or modified. The following conclusions were based on the monitoring effort.

The statistical exercise is of very little value other than the fact that it raises questions. Baseline data should be collected every day for a year (365 days) taken at high, low, ebb, and flood tides. These measurements should be correlated with depth and contour lines of the ocean bottom, the material on the bottom, existing structures such as jetties and piers, surf conditions, wind speed and direction, and rainfall intensity and duration levels in the runoff area. On stormy days or days of high surf, many of the measurements would be impossible to obtain due to dangerous conditions. On many of these days the area would attain maximum turbidity through natural conditions (storm, surf, rain, etc.). Turbidity levels above background can not always be measured, and natural turbidity by this standard can be significant (USACE, Los Angeles 1990).

The previously described turbidity monitoring studies were conducted at sites located in California and Florida where turbidity levels are in the 0 to 100 NTU range. The natural waters involved in these studies are relatively clear in comparison to the natural waters of the Gulf Coast states. In Texas, a turbidity monitoring effort was conducted at Laguna Madre (personal communication Hauch 1995). Turbidity measurements obtained at various sites concluded that background turbidity levels ranged from 0 to 600 NTU. In Alabama and Mississippi, some projects never violate a limit because the water is already so turbid (personal communication Rees 1995). Unfortunately, detailed information from studies in the Gulf Coast were not available for this paper.

# 3 Optical Properties of Light Transmission Through the Ocean

---

## Light

Electromagnetic waves are composed of various wavelengths and frequencies which together are termed electromagnetic radiation. In 1862, the British physicist James C. Maxwell determined that the propagation speed of light was the same as that of electromagnetic waves, and therefore, light waves were electromagnetic waves (Eisberg and Lerner 1981). Today, it is known that electromagnetic waves also propagate at wavelengths which differ from those of visible light. These wavelengths extend from  $10^{-15}$  to  $10^7$  m with corresponding frequencies from 25 to  $10^{21}$  Hz. Electromagnetic radiation is grouped into eight categories which characterize various forms of electromagnetic waves. The classification system used to categorize the various wavelengths and frequencies is termed the electromagnetic spectrum. The eight categories corresponding to the various wavelengths and frequencies of the electromagnetic spectrum are provided in Figure 4 (O'Shea 1985).

The visible light spectrum is located near the center of the electromagnetic spectrum and encompasses wavelengths to which the human eye is most sensitive. These wavelengths range from about 400 to 700 nm. In the visible light spectrum, a particular color is associated with the particular wavelength having the most energy concentrated within a relatively narrow band of wavelengths. The colors range from violet (400 nm) to red (700 nm). The color spectrum and the various colors associated with the various wavelengths of visible light are shown in Figure 4 (O'Shea 1985).

Light within the visible spectrum is the concern of this paper; however, it is not vision we are interested in, but the transmittance of light in the visible spectrum through ocean water.

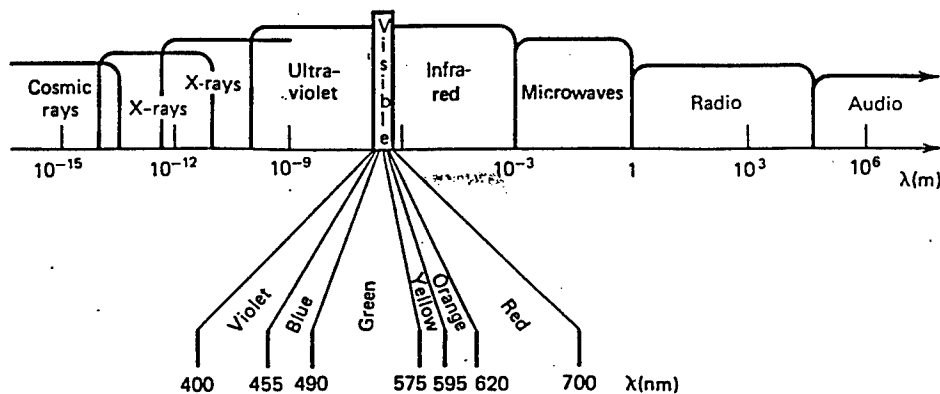

Figure 4. Electromagnetic spectrum (from O'Shea (1985))

## Inherent Optical Properties of the Sea

Optics is the scientific study of light (Eisberg and Lerner 1981). The behavior of light is greatly affected by the medium through which it passes. For instance, visible light behaves differently in water in comparison to air. Furthermore, visible light behaves differently in sea water than in fresh water. This is due to the various dissolved and particulate substances present in sea water (Jerlov 1976).

The propagation of light in the atmosphere and in the sea is dominated by different physical processes occurring in the atmosphere and in the ocean. The atmosphere is primarily a scattering medium whereas absorption and scattering are both significant processes in the ocean. To understand what happens to light as it propagates through the ocean, some measure of the extent to which the water absorbs and scatters light is necessary. The absorption and scattering properties of an aquatic medium for light of a given wavelength are specified in terms of absorption and scattering coefficients. The sum of absorbance and scatterance is referred to as attenuation (Kirk 1994).

Attenuation, absorption, and scattering as well as the properties which cause them are the inherent optical properties of the sea (Gordon, Smith, and Zaneveld 1984). An inherent optical property is one that is independent of the changes to the radiance distribution (Jerlov 1976); in other words, an optical property with magnitudes that are dependent only on the impurities or substances in the aquatic medium and not on changes in the light fields which infiltrate through the medium. These properties have precise mathematical definitions dictating how they should be measured (D&A Instruments 1989).

The physical properties that influence absorption and scattering of light through the ocean are provided with a ranking of significance relative to each other in Table 4. The concentration and size distribution of solids has the most significant effect. The index of refraction indicates the distinction

between organic and inorganic solid materials. The dissolved organic materials or molecules (i.e., tannic and humic acids) absorb transmitted light and result in the brownish color of water. One distinction between light absorption and scattering is that light scattering is not affected by dissolved organic material (Ritter and Ott 1974).

<b>Physical Property of Medium</b>	<b>Absorption</b>	<b>Scattering</b>
Concentration of Solid Materials	10	10
Size Distribution of Solid Materials	10	10
Index of Refraction of Solid Materials	3	3
Shape of Solid Materials	3	3
Color of Solid Materials	1	1
Dissolved Materials	3	0

## Transmittance

As a narrow beam of monochromatic light is transmitted through water, two physical processes occur as the light interacts with the dissolved or suspended particulate matter in the water. These physical processes are termed absorption and scattering. Absorption is the conversion of light to heat or energy with a different wavelength. Scattering is the redirection of light due to refraction, reflection, or diffraction caused by particles or scatterers. Figure 5 depicts the variables which define transmittance of light through a fluid sample. The distance or length in which the transmittance of light through the fluid sample will be measured is termed the pathlength  $l$ . The radiant fluxes,  $F_o$  and  $F_t$ , represent the radiant energy incident upon and transmitted through the sample fluid, respectively. Light transmittance is the ratio of the transmitted radiant flux to the incident radiant flux (Williams 1970). Light transmission is represented by the expression:

$$T = \frac{F_t}{F_o} \quad (1)$$

where  $T$  = total light transmission through the sample fluid.

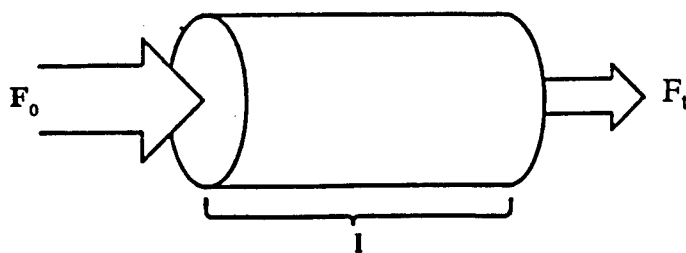

Figure 5. Light transmission through a sample fluid (after Williams (1970))

The process in which light energy is lost during transmittance is termed attenuation. Attenuation is the complement of transmission and is the sum of the measured absorption and scatterance of a narrow beam of light as it propagates through a medium. Attenuation is the only optical property that is inherently easy to measure in natural waters (D&A Instruments 1989). Figure 6 depicts the interaction of light with particulate matter as a narrow light beam propagates through the sample fluid. The expression which characterizes light attenuation is as follows:

$$c = a + b \quad (2)$$

where,  $c$ ,  $a$ , and  $b$  are coefficients of beam attenuation, absorption, and scattering, respectively. The coefficients all have units of  $1/\text{length}$ , and are expressed as  $\text{m}^{-1}$ . Although both processes occur simultaneously, there are instances where one or the other dominates. For example, visible light passing through a fog is attenuated almost entirely by scattering, whereas light passing along the shaft of a coal mine is attenuated primarily by absorption (Kirk 1994).

The fraction of light transmitted through a pathlength,  $l$ , is related to the attenuation,  $c$ , through the expression:

$$T = \frac{F_t}{F_o} = e^{-cl} \quad (3)$$

or

$$T = 100 e^{-cl} \quad (4)$$

where  $T$  in expression (4) provides  $T$  in percent transmissivity. A transmissivity of 100% indicates the medium is transparent with complete light

transmission through the medium and a value of 0% indicates that no light is transmitted through the medium; therefore, the medium is extremely turbid (Williams 1970).

If  $cl = 1.0$ , the light intensity will have decreased by  $1.0/e$  at the time it is measured. Transmission measurements are most accurate in the region where  $c$  is on the order of  $1.0/l$ , since in this region  $cl$  is not too close to zero and the signal is large enough that the intensities to be measured are not too low (Bartz, Zaneveld, and Hasong 1978).

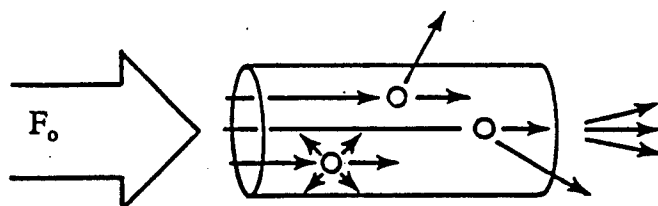

Figure 6. Interaction of light beam with particulate matter (after Williams (1970))

## Absorption

When molecules collide with each other in the liquid or gaseous state, or are in contact with each other in the solid state, there can be a transfer of energy between the molecules and this is accompanied by a transition of energy within the molecules themselves. The energy of the agitated molecules is dissipated in the form of heat or can be re-emitted as light. The energy dissipated as heat is absorbed and lost. The re-emission of energy as light is termed fluorescence. A very small amount of energy is re-emitted as fluorescence and the fluorescence light is usually re-absorbed back into the system. Therefore, the effects of fluorescence are insignificant when measuring the inherent optical properties of attenuation, absorption, and scattering in the sea (Kirk 1994).

In a homogeneous medium, the dominant attenuation mechanism is absorption. When scattering is negligible, the irradiance of a beam of light attenuated from the source through a sample of pathlength  $l$  is expressed as in equation 4 with the scattering effects excluded. There are four components in the aquatic ecosystem which contribute to the absorption of light in natural waters: the water itself, dissolved yellow pigments (by-products of decay of organic matter), the photosynthetic biota (phytoplankton), and dissolved or suspended inorganic particulate matter (Kirk 1994).

## Scattering

Scattering is the other physical process resulting in the diffusion of energy or light as it propagates in the ocean. Scattering is the redirection of light due to the interaction of light with particulate matter in the medium. The scatterance of light is relative to the size, shape, and composition of the particles in the medium, and the wavelength of the incident light. Scattering is the result of three physical phenomena (Williams 1970):

- 1) The scatterer acts as a reflector and energy is reflected from the surface of the individual particles.
- 2) Energy passing through the particle is deviated by refraction, and energy passing close to the particle is deviated by diffraction.
- 3) According to the approach of electromagnetic theory, the particle absorbs the light energy and then reradiates the light energy in all directions without a change in wavelength.

Reflection, refraction, and diffraction describe scattering in cases where the particles are large (particle radius greater than 10 times the wavelength) with respect to the wavelength of light. Large particles are common in the atmosphere (i.e., rain); however, particle sizes in the ocean are rarely larger than a few micrometers. Particulate matter in the ocean usually have radii less than ten times the wavelength of light penetrating the ocean. Therefore, the scattering of light in the ocean is explained through electromagnetic theory which is based on the work of Gustav Mie (1908). Mie developed a theoretical basis for predicting the light scattering behavior of spherical particles of any size. Mie assumed that particles resonated electromagnetically due to impinging energy or light. The particles then reradiate energy or scatter light in a manner based on the relative size of the particles with respect to the wavelength of the incident light (Williams 1970).

## Effect of Particle Size and Wavelength

Figure 7 is a plot of curves showing the variation in scattering for different wavelengths in air. Note the relative scattering curve for Rayleigh scattering. Rayleigh scattering, which is inversely proportional to the fourth power of wavelength, is predominant in the atmosphere. As shown in Figure 7, the amount of scatter does not vary linearly with particle size. For very small particles, there is a large amount of scattering at the shorter wavelengths. Conversely, there is a small amount of scattering at the longer wavelengths. As particle size increases from  $r=0.2$  to  $1.4 \mu\text{m}$ , scattering decreases at the lower wavelengths and increases at the higher wavelengths. Peaks of minimum and maximum scattering occur at the extreme ends of the wavelength scale for particle sizes of approximately  $1.4 \mu\text{m}$ . As particle size increases from  $r=1.4$  to  $r=2.0 \mu\text{m}$ , scattering increases in the shorter wavelengths and

decreases in the longer wavelengths. The scattering trends then reverse as particle size continues to increase from  $r=2.0$  to  $r=2.6 \mu\text{m}$ . Note that scattering is approximately the same at all wavelengths when particle size is approximately  $0.8 \mu\text{m}$  (Williams 1970).

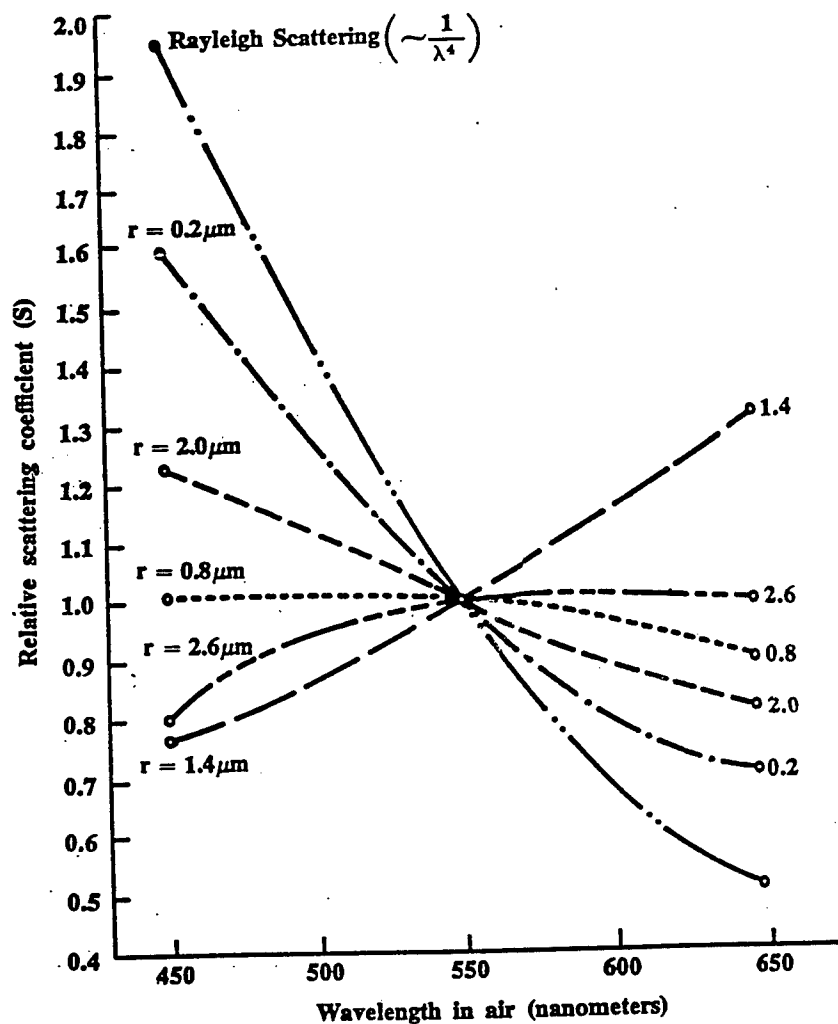

Figure 7. Scattering of particles of varying size (after Williams (1970))

As shown in Figure 6, scattering patterns resulting from the interaction of light with spherical particles is multi-directional. The terms used to describe the directions of scatter are forward scatter (45 deg from light path), 90 deg scatter (perpendicular to light path), and backward scatter (90 to 180 deg to light path). The directional distribution of light scattering is dependent on the ratio of particle size to the wavelength of incident light. Figure 8(a-c) depicts the resulting angular patterns of scattering intensity as the ratio of particle size to wavelength increases (Hach, Vanous, and Heer 1990).

When the particles are much smaller than the wavelength of incident light ( $r/L=1/10$ ), the scattering distribution is symmetrical with approximately equal amounts of light scattering in the forward and backward directions, Figure 8a. As the particle size increases relative to the wavelength ( $r/L=1/4$ ), light scatters from different points of the particle and scattering is increased in the forward direction, Figure 8b. The effect of a particle size larger than the incident wavelength of light is shown in Figure 8c. Scattering increases in all directions with a large concentration of the scatter in the forward direction (Hach, Vanous, and Heer 1990).

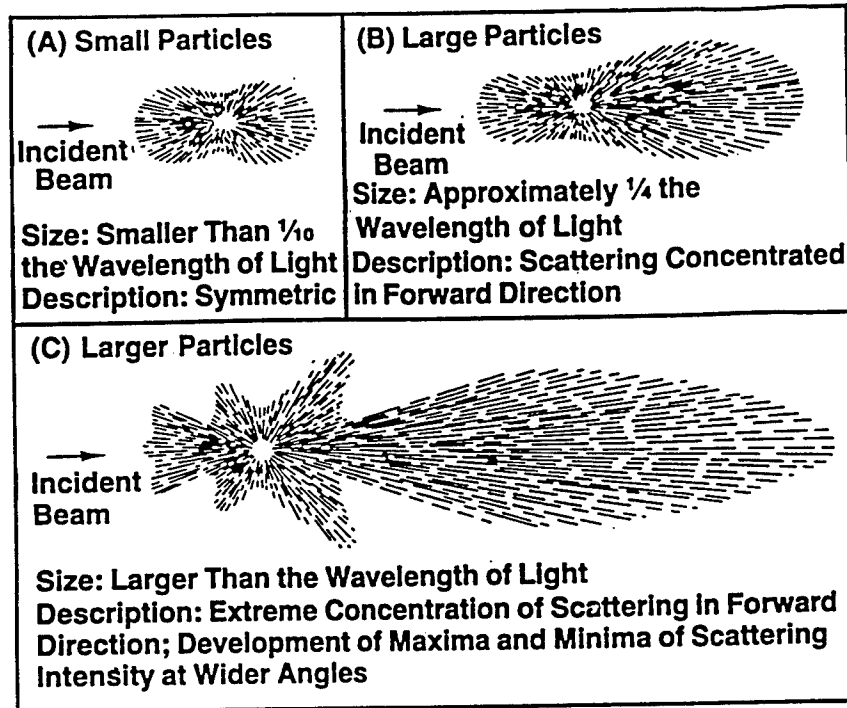

Figure 8. Angular patterns of scatterance distribution (from Hach, Vanous, and Heer (1990))

## Effects of Other Variables

Particle shape and refractive index play secondary roles compared to particle size in light scattering in the ocean (Gordon, Smith, and Zaneveld 1984). The refractive index of a particle is a measure of how the particle redirects light passing through it. In order for scattering to occur, the refractive index of the particle must differ from the refractive index of the medium. As the difference between the refractive indices of suspended particles and medium increases, scattering becomes more intense (Hach, Vanous, and Heer 1990).

Particle shape also affects scatter distribution and intensity. Spherical particles result in a larger forward-to-back scatter ratio than coiled or rod-shaped particles (Hach, Vanous, and Heer 1990). The forward scattering of randomly oriented irregular particles is similar to that of a suspension of spheres having equivalent radius. In the backward scattering region, the influence of shape can be large, therefore, scattering calculations in the backward region by Mie theory is usually not successful (Gordon, Smith, and Zaneveld 1984).

The color of suspended solids and sample fluid are significant in light scattering. A colored substance absorbs light energy in certain bands of the visible spectrum, changing the character of both transmitted light and scattered light and preventing a certain portion of the scattered light from reaching the detection system (Hach, Vanous, and Heer 1990).

Light scattering increases as particle concentration increases. But as scattered light strikes more and more particles, multiple scattering occurs and absorption of light increases. When particulate concentration exceeds a certain point, detectable levels of both scattered and transmitted light drop rapidly, marking the upper limit of measurable turbidity (Hach, Vanous, and Heer 1990).

## 4 Prototype Sensor Conceptual Design

---

The turbidity sensor designed and fabricated through this study is a required component of an overall turbidity monitoring system designed for in situ, long-term measurements. The overall turbidity monitoring system is currently in the conceptual design phase. Design, development, and laboratory calibration of the turbidity sensing device, which is the focus of this study, provides the basis for the design and development of a turbidity sensor and monitoring system for field use. Development of the overall monitoring system will be optimized through laboratory findings. The turbidity sensing device is based on the theoretical principles of an optical beam transmittance meter for sensing the transmission or attenuation of light through a given medium. At first glance, a beam transmittance meter seems a simple sensor to develop. However, for the overall purposes of this study, the ability of the sensor to function and survive in the ocean environment must be taken into consideration. The conceptual design of the prototype monitoring system for field use is presented in this section. The design, development, and laboratory calibration of the transmissometer is presented in Part V.

### Prototype Sensor Considerations

The sensor design must take into consideration both the impact the environment will have on the sensor, and the impact the sensor will have on the environment. Factors inherent to the environment include waterproofing to prevent leakage to system components, resistance to biological fouling and corrosion of components exposed to the environment, pressure differentials, and possible effects of marine life. Factors inherent to the sensor include being non-intrusive or damaging to the environment or marine life. Human factors must also be taken into consideration when designing instrumentation to be unsupervised during deployment in an unrestricted location. Human factors include fishermen, shrimpers, scuba divers, etc., as well as the vessels and equipment used for these operations.

The turbidity monitoring system must also meet the following requirements:

- 1) Collection of continuous, in situ measurements with operational ease under a variety of sea and weather conditions.
- 2) Temperature stability.
- 3) Fixed optical alignment.
- 4) Insensitive to ambient light.
- 5) The parameter measured should be environmentally relevant.
- 6) Ability to measure range of turbidity encountered in potential study areas.
- 7) Detection of fouling or system degradation for valid turbidity measurements.
- 8) Appropriate mounting structure.
- 9) Feasible method for deployment and retrieval.
- 10) Reasonable cost and maintenance requirements.

## Biological Fouling

Marine or biological fouling is the result of settlement and growth of animals and plants (including bacteria) on the surface of and in objects immersed in the sea by man. Adverse effects of biological fouling include reduced efficiency of vessel propulsion and destruction of wharfs and pilings. However, severe problems are encountered relative to navigation buoys, underwater cables, equipment, and oceanographic sensing devices. The tendency for biological organisms to settle is influenced by the surface contour, texture and composition, and color of the substratum, as well as lighting conditions, currents, tides, depth, and other physical parameters (Pequegnat, Gaille, and Pequegnat 1967). Biological fouling of any moored optical instrument can be extremely damaging and is the most prevalent deterrent in obtaining continuous in situ optical turbidity measurements over durations longer than a few days, and the rate of fouling is accelerated in warm shallow water. Biological fouling degrades system optics, mechanics, and may contaminate the sample of medium (Ridd and Larcombe 1994).

Optical instruments are the most susceptible to biological fouling. The measurement area or windows are usually exposed to the ocean on a continual basis. The biological growth on the lenses makes it extremely difficult, if not impossible, to extract a measurement due to the system degradation. Currently, deployed optical instruments must be cleaned on a daily to weekly basis during warm months when biological growth is at a maximum, and only last an approximate one month deployment during the cooler months when biological growth is minimal. A few ways to mitigate biological fouling are to paint the instrument housing and parts with biologically resistant paint, clean instrument components periodically, use biologically inert materials such as PVC, keep mechanical components to a minimum, and keep measurement areas such as the optical lenses from contacting the ocean environment.

## Conceptual Design

A schematic of the prototype turbidity sensor for in situ, long-term deployment is provided in Figure 9. The basic sensor design is to enclose a flow-through sampling cell of fixed volume within a water-tight housing. A transmissometer is used to measure the turbidity of the fluid inside the sampling cell. Prior to deployment, the transmissometer will be calibrated to a reference fluid of known properties. The reference fluid is derived with the primary characteristic that it resist biological fouling. The system will fill the sampling cell with a fixed volume of reference fluid. The transmissivity of the reference fluid is measured. The reference fluid in the sampling cell is then flushed out of the system and replaced with a fixed volume of ambient fluid. The transmissivity of the ambient fluid is then measured. To minimize the opportunity for biological growth, the ambient fluid in the sampling cell is immediately flushed out of the system and replaced with the biologically resistant reference fluid. The transmissivity of the reference fluid within the sampling cell is again measured. The cyclic filling and flushing of the sampling cell, and transmissivity measurement of the fluid within the sampling cell, is repeated at a regular interval to produce, overtime, a long-term measurement of turbidity. The cyclic exchange and transmissivity measurement of the reference fluid provides a continuous system recalibration prior to each transmissivity measurement of the ambient fluid. Any change in transmissivity of the reference fluid will provide data to detect biological fouling of the sampling volume or degradation of the system components based on the original properties of the reference fluid and prior measurements. Accurate turbidity measurements of the ambient fluid can be extracted from the recalibration data (Howell 1993a).

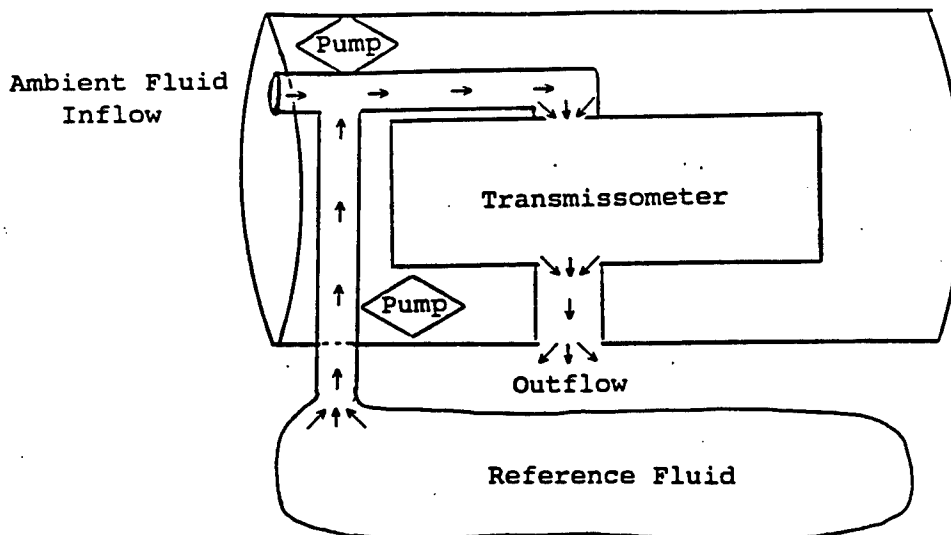

Figure 9. Conceptual design of turbidity monitoring system

The system is deployed with a sufficient volume of reference fluid to allow flushing of the sampling volume based on a specified sampling interval and deployment duration. The reference fluid is contained in a compressible bladder to avoid effects of pressure differentials as the volume of reference fluid decreases. The system is installed in a bottom-mounted pod (Figure 10) designed to protect the instrumentation from fishing trawlers. The outrigger pipes extend into the sediment to hold the system in place. The design of the pod allows other oceanographic instrumentation to be mounted and deployed with the turbidity sensor (Howell 1993b).

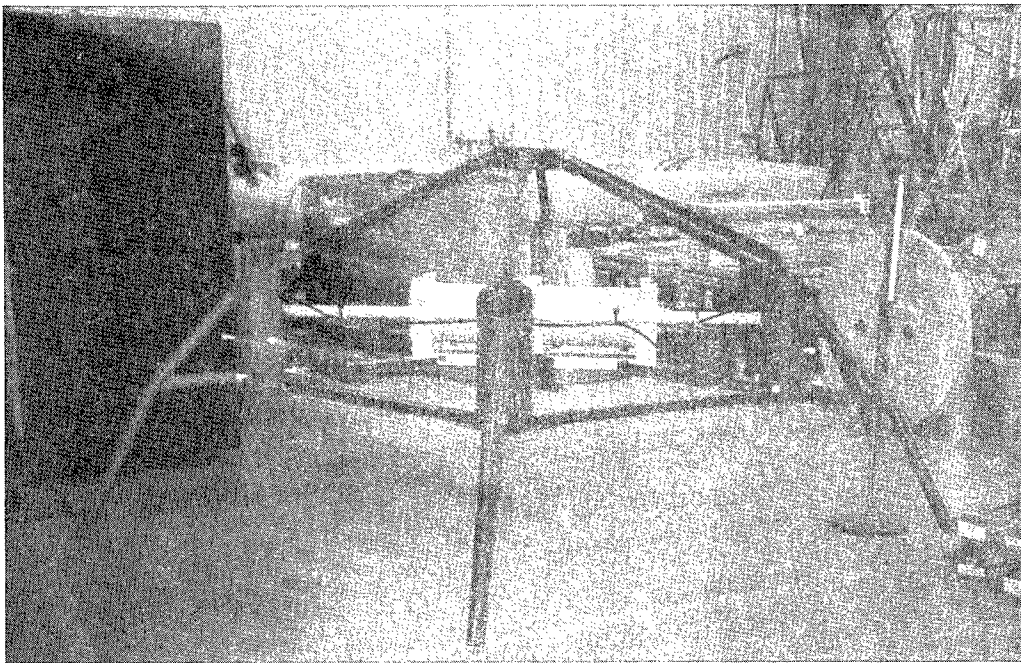

Figure 10. Turbidity monitoring system mounting pod

## 5 Transmissometer Design and Fabrication

---

The approach used in the instrument's design was to take known and proven techniques and develop a reliable instrument for laboratory measurements of light transmission. The basic design of the beam transmissometer is shown schematically in Figure 11. The transmissometer consists of a light source for projecting light, a sampling cell to contain the sample of medium, and a photocell for detecting the intensity of the light transmitted through the sampling cell. The transmissometer uses two lenses to transmit light from the source to the detector. One lens is used to project a collimated beam from the light source through the sampling cell. The second lens is used to focus the light transmitted through the sampling cell to the detector.

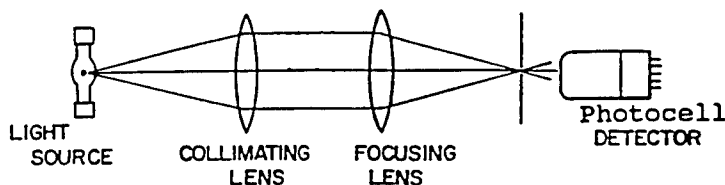

Figure 11. Schematic of beam transmissometer (after Kirk (1994))

The components of the transmissometer were mounted and enclosed in a housing constructed of PVC pipe, Figure 12a. The housing prevents ambient light from entering the optical system. PVC piping was used to simplify the design and minimize costs. Three configurations of the sampling cell, shown in Figure 13a-c, were tested and evaluated. The three configurations were: 1) a glass cylindrical sampling cell positioned vertically, 2) a glass cylindrical sampling cell positioned horizontally, and 3) a T-shaped PVC pipe, which is also the housing, positioning the sampling cell horizontally. Use of the glass sample cell positioned vertically produces stray scattered light as the beam enters and exits the cell due to the curvature of the glass. This stray light reaches the detector resulting in erroneous measurements. Positioning the sample cell horizontally reduces the stray light introduced to the system by providing flat entrance and exit windows for the beam. This configuration

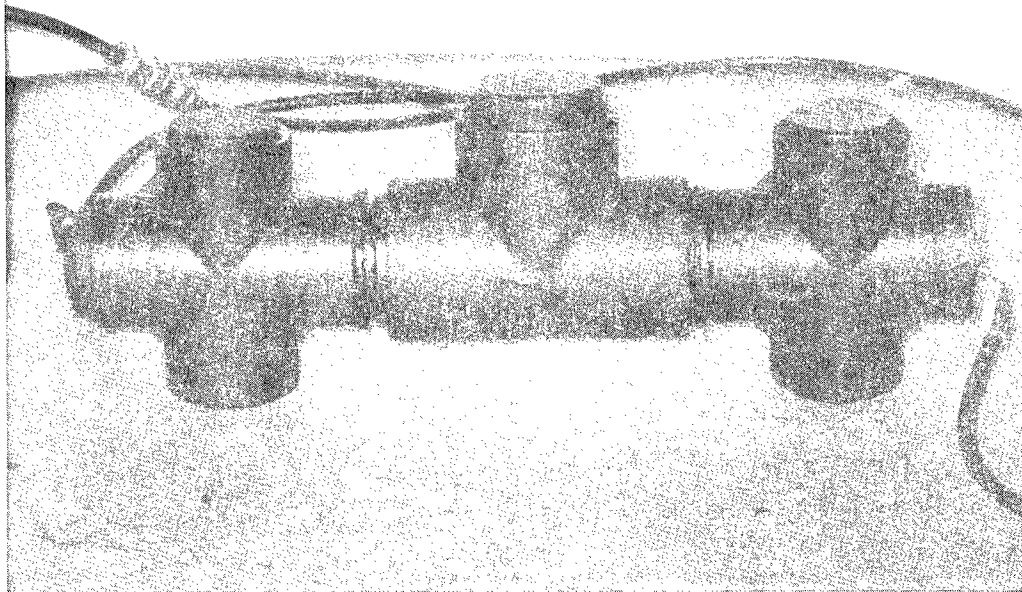

Figure 12a. Transmissometer PVC-pipe housing

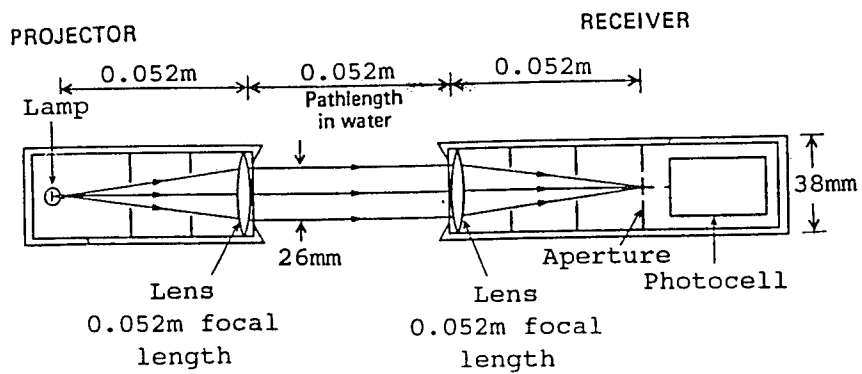

Figure 12b. Schematic of interior sensor

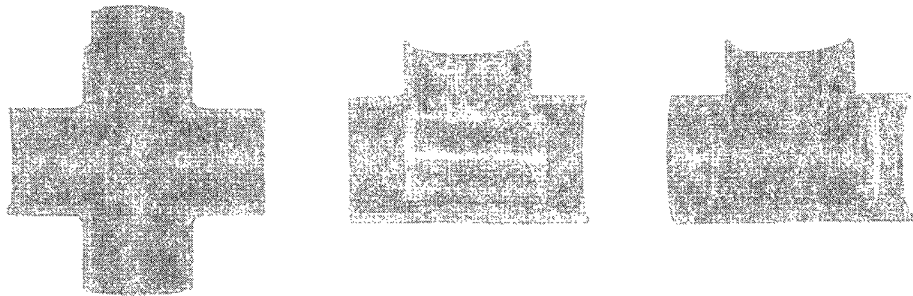

Figure 13. Sampling cell configurations: (a) glass cylindrical sampling cell positioned vertically, (b) glass cylindrical sampling cell positioned horizontally, and (c) T-shaped PVC pipe sampling cell positioned horizontally

medium decreases, therefore decreasing the intensity detected by the photocell. The intensity of the beam must increase until enough light is transmitted to the photocell to return  $V_r$  and  $V_p$  to equilibrium. Operating in this mode attempts to decrease the non-linearity of the photocell and is an effort to reduce power consumption of the system. Energy is conserved by supplying the bulb only with the voltage necessary to maintain a constant intensity across the photocell rather than supplying a constant voltage to maintain a constant beam intensity and vary the photocell response. The circuit was designed to allow adjustment of the system input intensity,  $V_r$ . The adjustment of  $V_r$  varies the sensitivity of the circuit for different ranges of turbidity. The response of the sensor to the adjustment of  $V_r$  is presented in Section VI. The sensor will be deployed with  $V_r$  set to the appropriate range corresponding to the expected turbidity of the medium. The optimal response of the sensor to  $V_r$  sensitivity is to have one setting for all turbidity ranges.

The intensity of the bulb,  $V_a$ , is related to the attenuation,  $c$ , of the medium through equation (3) which is repeated here:

where  $T$  = light transmission

$$T = \frac{F_t}{F_o} = e^{-cl} \quad (5)$$

$F_t$  = transmitted light flux through the sampling medium  
 $F_o$  = incident light flux produced by the light source  
 $l$  = beam transmittance pathlength

and

$$\frac{F_t}{F_o} = \frac{V_r}{V_a} \quad (6)$$

therefore

$$c = \frac{-\ln\left(\frac{V_r}{V_a}\right)}{l} \quad (7)$$

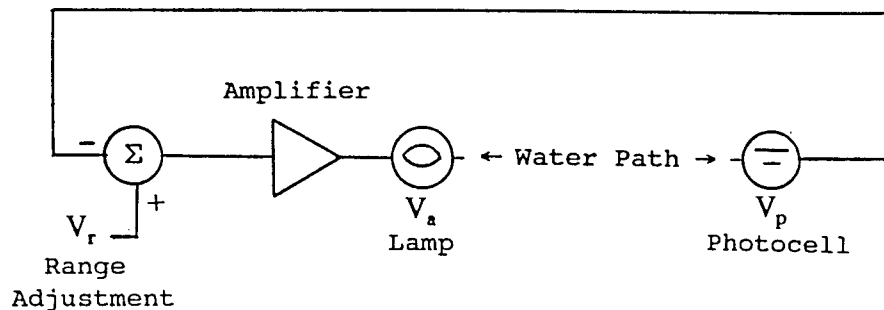

Figure 14. Schematic of transmissometer circuit

To properly measure attenuation,  $c$ , it is necessary to determine how much light remains after the light has traversed through the sample volume. This is the residual light that has been neither absorbed nor scattered by the medium. If true measurement of attenuation is to be determined, the photocell must only receive light that has not deviated from the original path of travel. It is difficult, if not impossible, to eliminate all forward scattered light from reaching the photocell in a practical field instrument of this nature. All beam transmittance systems accept some forward scattered light depending on the acceptance angle or field of view of the detector (Petzold and Austin 1968). The sensor developed in this study is based on the assumption that any light which re-emerges from the system is considered transmitted. Therefore, the mea-

sured attenuation may include some scatterance as well as light which is neither absorbed nor scattered through the medium. The important consideration in this assumption is that the measurement accuracy corresponds with the potential uses of the sensor and data.

## 6 Sensor Tests and Results

---

### Sensor Calibration

Beam attenuation measurements were collected using formazin solutions prepared according to procedures outlined in Standard Methods (1971) and verified using an HF Scientific DRT-100B Research Turbidimeter. To calibrate the sensor to the full range of possible turbidity levels which may be encountered in USACE projects, formazin solutions prepared ranged from 0.02 to 900 NTU. A total of 21 NTU solutions were prepared. Table 5 lists the NTU levels of the prepared formazin solutions and the increment,  $\Delta$ , in which the NTU solutions increased. The HF Scientific DRT-100B Research Turbidimeter is designed with an adjustment that must be set to the appropriate turbidity range corresponding to the expected turbidity range of the sample. The ranges of adjustment are 0 to 10 NTU, 10 to 100 NTU, and 100 to 1000 NTU. The transmissometer was designed with a similar adjustment to determine the ranges of  $V_r$ , the intensity input to the circuit, which provide the required sensitivity to extract attenuation variations in the turbidity ranges from 0 to 1000 NTU. Therefore, the response of the transmissometer to the 21 formazin solutions ranging from 0.02 to 900 NTU as well as sensitivity ranges of the sensor from  $V_r = 0.08$  to 0.35 were tested and evaluated. By accurately determining the correlations of transmissometer attenuation with turbidimeter readings of NTU, the attenuation of other samples may be determined in NTUs based on the correlations.

A reference fluid was also evaluated in the laboratory tests. The ideal reference fluid to be used in the system would be resistant to all biological growth. The tested reference fluid which meets this criteria was simple bleach. Five solutions of bleach diluted with 0.02 NTU water were evaluated. The dilutions of bleach to water were: 100%, 75%, 50%, 25%, and 10%. The NTU of the solutions were measured using the turbidimeter. All solutions had an NTU value of 0.08. The solution of 25% bleach was tested with the formazin solutions. The 25% solution was chosen since it was a low concentration of bleach but was considered significant for resisting biofouling.

The procedure used to calibrate the transmissometer is as follows. The turbidimeter was calibrated using 0.02, 8, and 800 NTU standards prior to the

collection of measurements. To verify the NTU of the solution to be measured

Table 5 Formazin Solutions for Sensor Calibration	
Range (NTU)	Increment $\Delta$ (NTU)
0.02	-
10 - 20	5
30 - 60	10
80 - 100	20
150 - 500	50
600 - 900	100

in the transmissometer, 30 ml of the desired NTU formazin solution were placed in the turbidimeter sampling cell and inserted in the turbidimeter. The NTU reading of the sample was recorded. In cases where the NTU reading deviated from the desired NTU value, the concentration of the original solution was adjusted and re-measured until the desired NTU was obtained. The NTU solution was then poured into the 65 ml transmissometer sampling cell. The intensity of the beam,  $V_a$ , was recorded as  $V_r$  was adjusted to 0.08, 0.12, 0.15, 0.20, 0.25, 0.30, 0.32, 0.34, and 0.35 volts. Both sampling cells were thoroughly rinsed of the formazin solutions in preparation for the next set of measurements. The procedure was repeated for the remaining formazin solutions as well as the bleach solution. Nine pairs of ( $V_a, V_r$ ) measurements were recorded for each solution ranging from 0.02 to 900 NTU.

Figure 15 is a plot of the measured beam intensities,  $V_a$ , corresponding to the formazin solutions. The abscissa represents NTU and the ordinate represents the corresponding  $V_a$  value. Each set of connected points, distinguished by a symbol, represent the response of the transmissometer to a specific  $V_r$ , ranging from 0.08 to 0.35 volts. The plot shows that the transmissometer was saturated at the  $V_r=0.35$  volts setting and there was no response at the low setting of  $V_r=0.08$  volts. The plot also shows that the transmissometer became saturated at various points depending on the combination of  $V_r$  and NTU values.

The attenuation coefficients corresponding to each pair of ( $V_a, V_r$ ) readings,  $V_r$  ranging from 0.12 to 0.34 volts, were calculated using equation (7). The results are plotted in Figure 16. The abscissa represents NTU and the ordinate represents the corresponding attenuation coefficients. The dashed lines represent the results of linear regression calculations conducted for each set of data corresponding to the  $V_r$  settings. The results of the linear regression are

provided in Table 6. Depending on the range and  $V_r$  selected for system operation, the corresponding linear relationship in Table 6 can be used to extract the NTU relative to the calculated beam attenuation coefficient. The plotted results show that  $V_r$  settings of 0.30 to 0.32 volts should be used for turbidity ranges between 1 to 100 NTU, 0.20 to 0.25 volts for ranges between 100 to 600 NTU, and 0.15 volts for turbidity ranging from 500 to 900 NTU.

The linear relation between attenuation coefficient and NTU is expressed as:

$$NTU = mc + b \quad (8)$$

where  $m$  = slope of line  
 $b$  = intercept

$V_r$ Input Intensity	$n$ Number of Observations	$\sigma$ Standard Deviation	$m$ Slope of Regression	$b$ Intercept	$r$ Correlation Coefficient	$r^2$
.12	23	23.309	66.348	-241.094	0.99665	0.99332
.15	23	33.628	41.290	-128.241	0.99302	0.98609
.20	21	16.779	29.921	-102.546	0.99716	0.99433
.25	17	5.556	21.965	-129.147	0.99916	0.99832
.30	13	6.525	18.001	-196.656	0.99470	0.98944
.32	11	4.652	13.352	-179.379	0.99095	0.98198
.34	5	4.210	15.377	-265.656	0.91248	0.83280

## Degradation of the System

The turbidity monitoring system is designed to resist biological fouling and eliminate the impacts resulting from fouling. However, fouling due to the ocean environment cannot be eliminated. Therefore, the impacts of system fouling must be evaluated. Tests were conducted to determine if fouling could be detected, what the impacts of fouling are, and if an accurate measurement could be extracted from the data collected. The transmissometer was artificially fouled by coating the lenses with petroleum jelly. This was an effort to simulate biological growth on the lenses. It also served to evaluate condensation on the lenses. The measurement procedure previously outlined was con-

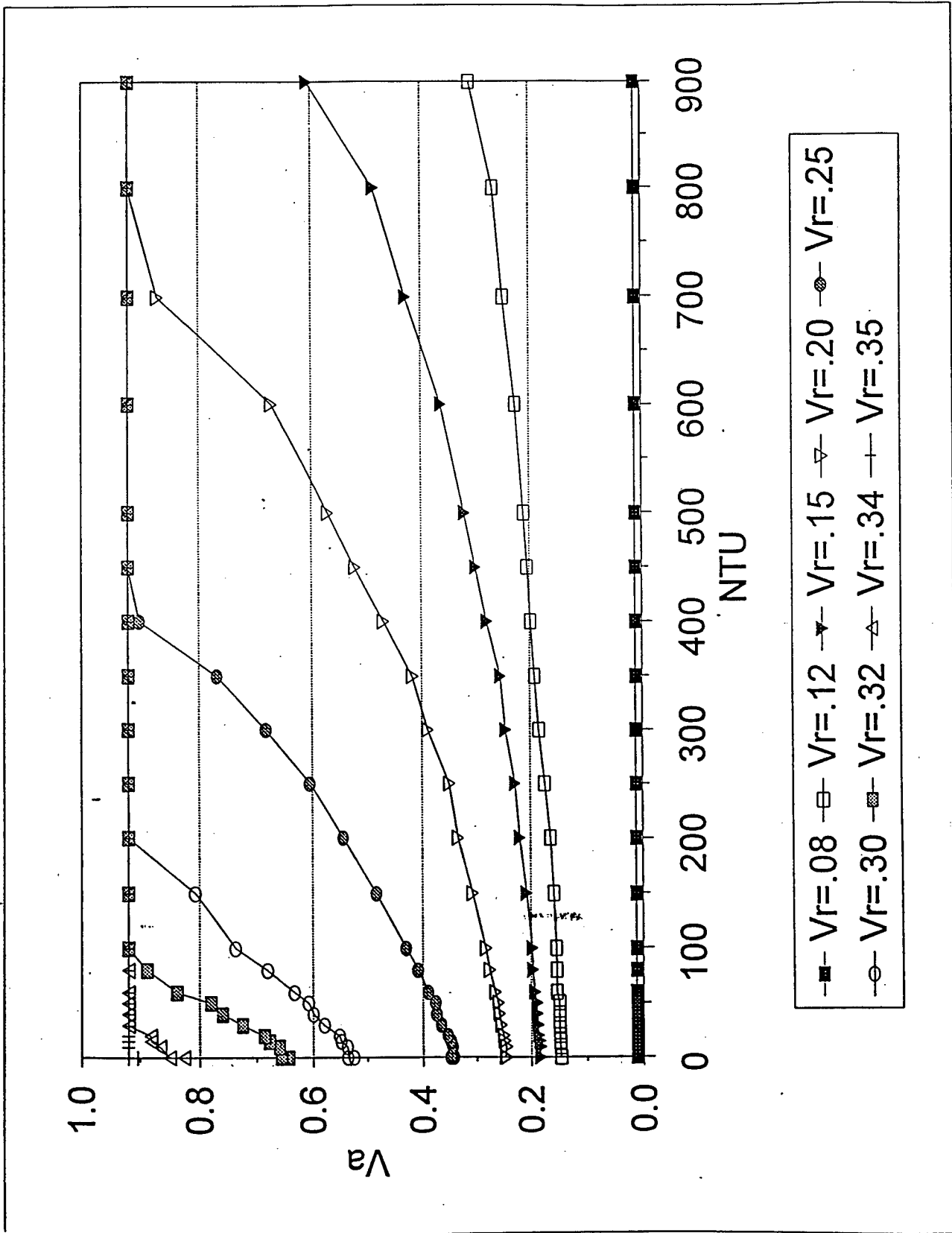

Figure 15. Beam intensities ( $V_a$ ) versus NTU corresponding to  $V_r$  settings of 0.08, 0.12, 0.15, 0.20, 0.25, 0.30, 0.32, 0.34, and 0.35 volts

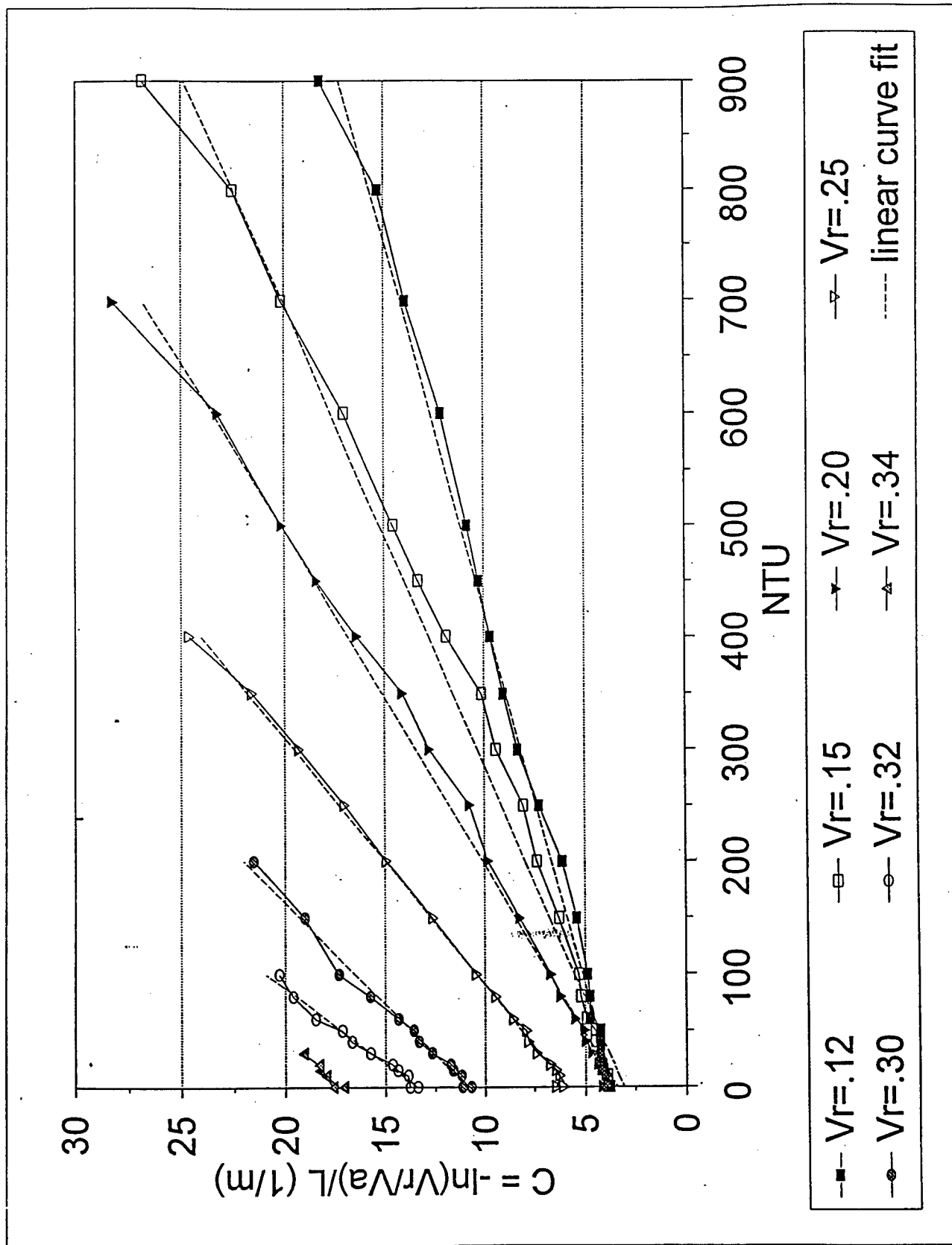

Figure 16. Attenuation coefficient (c) versus NTU corresponding to  $V_r$  settings of 0.08, 0.12, 0.15, 0.20, 0.25, 0.30, 0.32, 0.34, and 0.35 volts

ducted to measure the response of the sensor to fouling. This set of tests is referred to as "light fouling". A second degree of fouling was simulated by simply smearing an additional layer of petroleum jelly on the lenses and repeating the test procedures. These set of tests are referred to as "moderate fouling". A linear regression of attenuation and NTU for the fouling results was calculated. Plots of the sensor response to fouling and the linear relationships are provided in Figures 17 and 18. A tabular listing of the linear regression analysis are provided in Tables 7 and 8. Figure 19 is a comparison of linear regression curves prior to fouling and with the two degrees of fouling (light fouling and moderate fouling) for  $V_r$  settings of 0.15, 0.25, 0.30 volts. These settings of  $V_r$  were selected to show the impact of fouling in the three turbidity ranges. The results from some  $V_r$  settings are not shown in an effort to legibly show the results.

Figure 19 shows that in the low  $V_r$  range ( $V_r=0.15$  volts) the sensor is sensitive to fouling at turbidity ranging from 0 to about 300 NTU. However, in the high turbidity range, 300 to 900 NTU, the impact of fouling is not significant or not detected. The curves corresponding to a  $V_r$  value of 0.25 and 0.30 volts used for turbidity ranges from 100 to 400 NTU and 0 to 100 NTU, respectively, show that the slope of the relationship remains nearly intact, and the impact of fouling merely increases the offset of the relationship. Therefore, the test results show that fouling introduced to the system can be detected, and the attenuation coefficient, or turbidity of the medium, can accurately be extracted from the data.

$V_r$ Input Intensity	n Number of Observations	$\sigma$ Standard Deviation	m Slope of Regression	b Intercept	r Correlation Coefficient	$r^2$
.12	23	27.875	68.550	-253.573	0.99519	0.99040
.15	23	33.116	41.807	-142.376	0.99324	0.98652
.20	21	19.064	30.897	-125.128	0.99634	0.99270
.25	17	4.175	22.737	-156.587	0.99952	0.99905
.30	13	2.488	15.561	-186.202	0.99865	0.99730
.32	11	2.580	11.654	-172.192	0.99368	0.98739
.34	5	3.288	18.053	-333.275	0.91433	0.83600

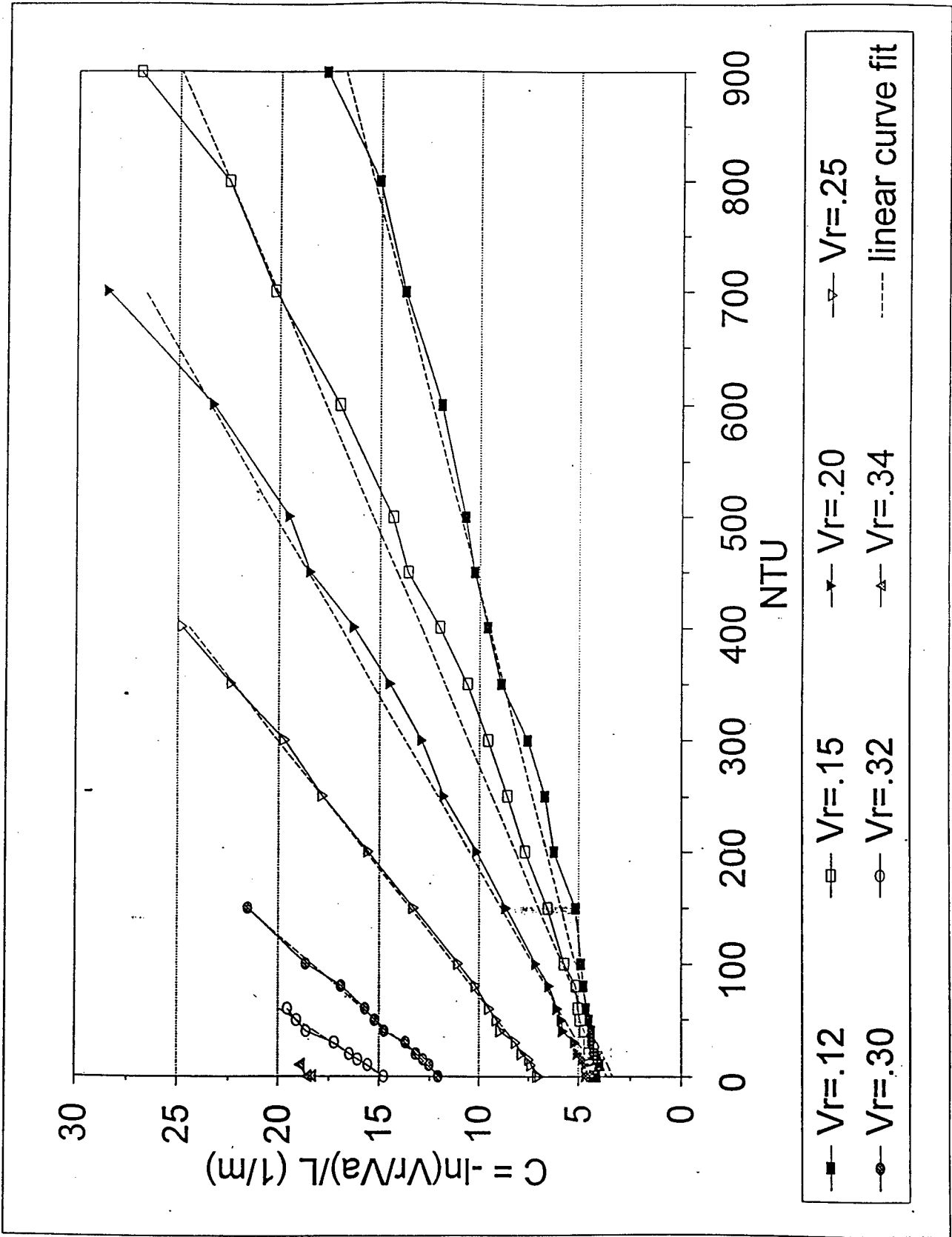

Figure 17. Attenuation coefficient (c) (light fouling) versus NTU corresponding to  $V_r$  settings of 0.08, 0.12, 0.15, 0.20, 0.25, 0.30, 0.32, 0.34, and 0.35 volts

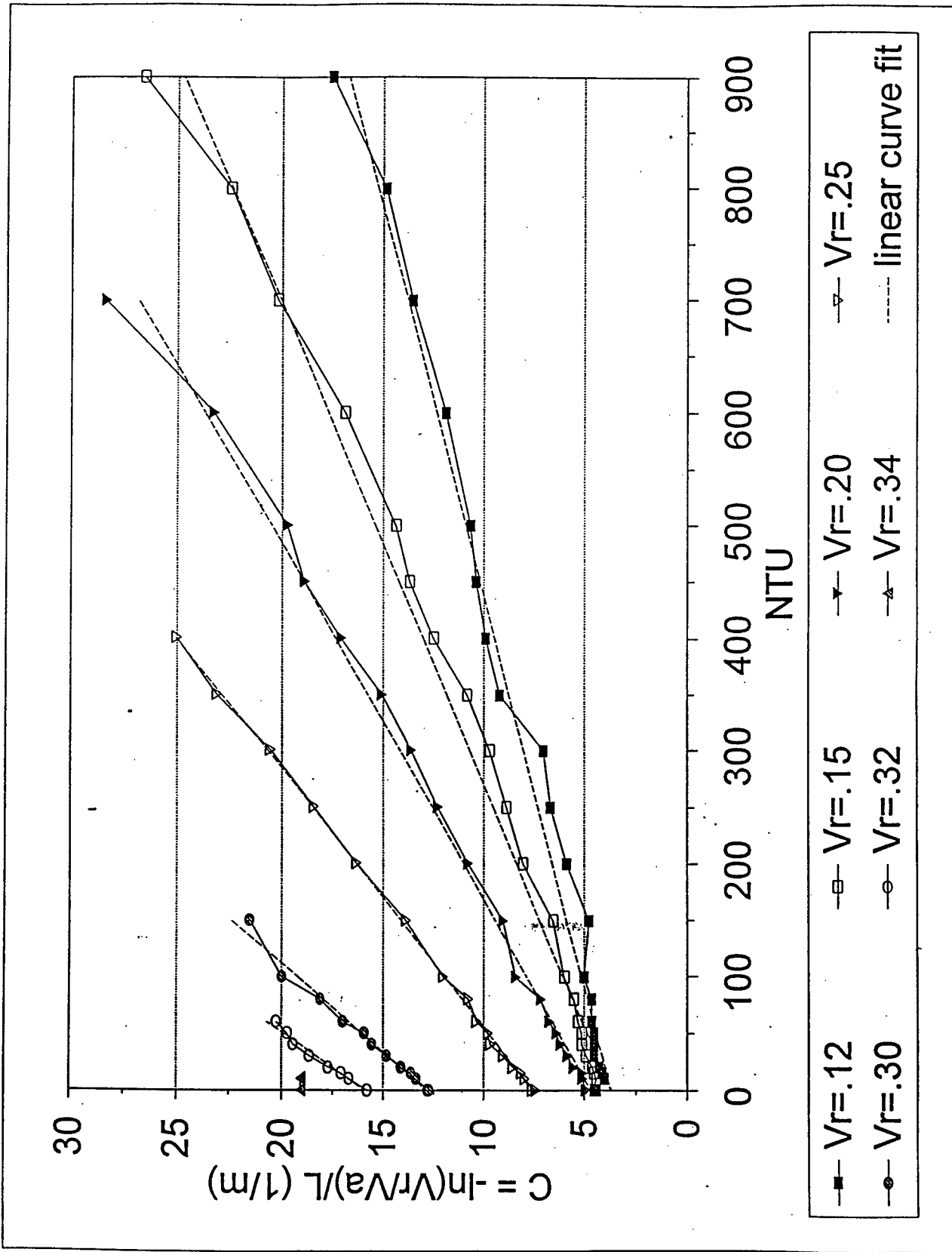

Figure 18. Attenuation coefficient (c) (moderate fouling) versus NTU corresponding to  $V_r$  settings of 0.08, 0.12, 0.15, 0.20, 0.25, 0.30, 0.32, 0.34, and 0.35 volts

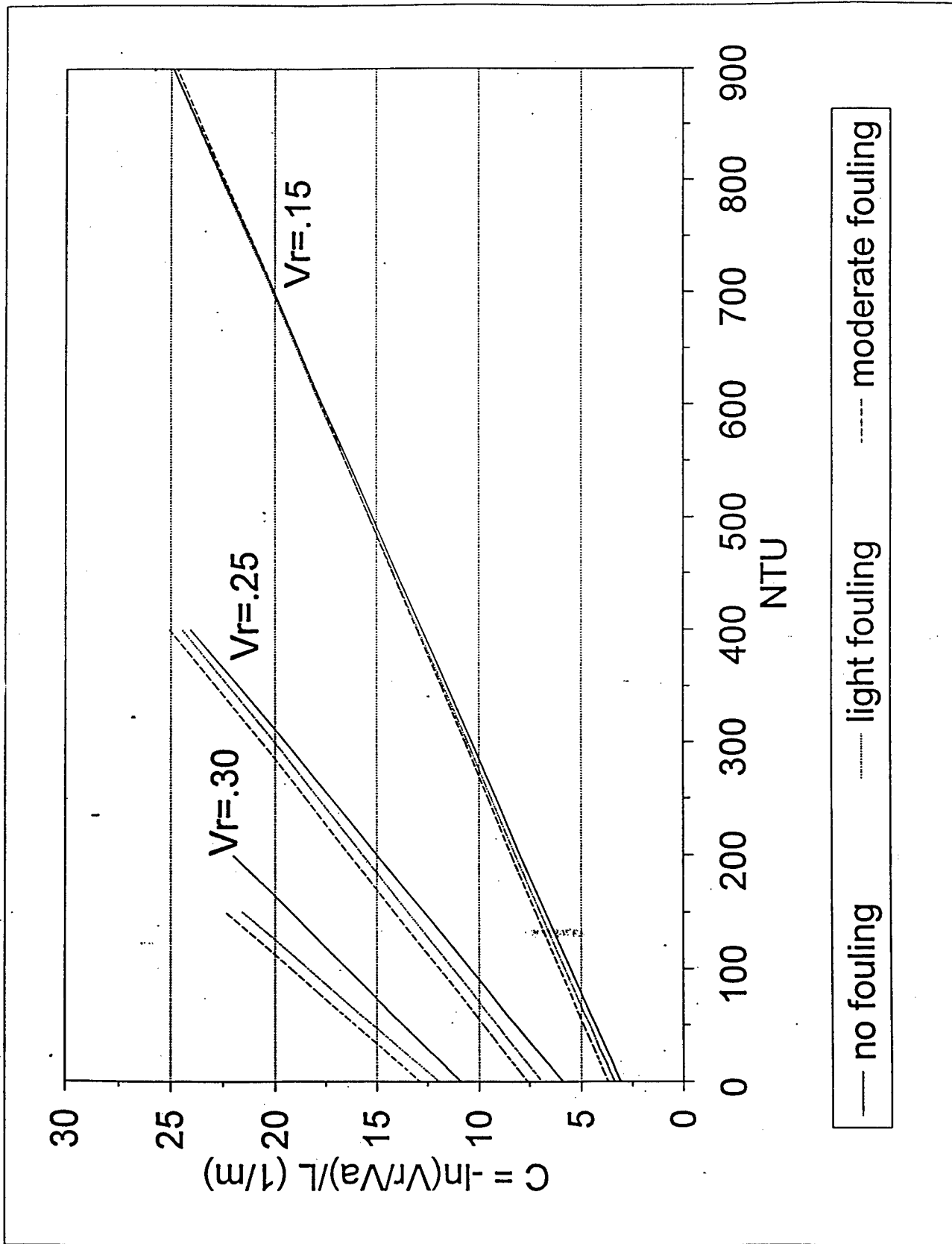

Figure 19. Comparison of linear regression curves corresponding to attenuation versus NTU in cases with no fouling, light fouling, and moderate fouling

**Table 8**  
**Correlation of Attenuation Coefficient and NTU (Moderate Fouling)**

$V_r$ Input Intensity	n Number of Observations	$\sigma$ Standard Deviation	m Slope of Regression	b Intercept	r Correlation Coefficient	$r^2$
.12	23	37.916	69.393	-257.744	0.99111	0.9823
.15	23	31.363	42.856	-159.339	0.99394	0.9879
.20	21	15.994	31.590	-148.124	0.99740	0.9948
.25	17	4.023	22.875	-173.600	0.99956	0.9991
.30	12	6.297	15.724	-202.402	0.99116	0.9824
.32	9	3.504	12.454	-198.189	0.98830	0.9767
.34	3	0.035	474.476	-9052.962	1.00000	1.0000

## 7 Future Work

---

The overall turbidity monitoring system will continue to be developed. The results of this study will be used to modify the system design, specifically the transmissometer. The next phase in development is to design and construct a sampling volume with the capability to flush the reference and ambient fluids through the system. The sensor test will be repeated to monitor any impacts of flushing the media through the system. A water tight housing for the system will then be designed, fabricated, and tested in the laboratory. Once the laboratory turbidity monitoring system has met the requirements, a field system will be developed based on the design of the laboratory system. The end result will be a field turbidity monitoring system capable of collecting long-term, in situ turbidity measurements over the range of turbidities encountered on USACE projects. The system will provide measurements which correlate to the legally acceptable units specified by water quality standards.

## 8 Summary

---

Turbidity is an optical property; however, the definition of turbidity is ambiguous due to the various fields of science and engineering investigating turbidity. Scientists define turbidity according to the causes and effects of turbidity relative to their specific interests. There are several methodologies and types of instrumentation for measuring turbidity, which add to the confusion of defining turbidity. For the purposes of this study, turbidity is the effect on light transmission through a medium due to the dissolved or suspended particulate matter in the medium. Excessive turbidity reduces light penetration resulting in reduced photosynthesis and adverse impacts to aquatic life. A measure of the turbidity of a medium indicates such information as the esthetics of a water body, biological conditions, and pollution.

Light attenuation is an inherent optical property of the ocean, therefore, it is dependent on particulate matter and dissolved materials in the medium. Attenuation, which is the sum of absorption and scattering, is the diffusion process which affects the transmittance of light. As the turbidity of the medium increases, the absorption and scattering of light due to particulate matter in the medium also increases. Light transmission is the complement of attenuation. An increase in attenuation corresponds to a decrease in transmission.

Available data collected from turbidity monitoring efforts on various projects concludes that background turbidity levels and levels measured during project construction may vary from 0 to 100 NTU in regions considered relatively clear, such as Florida and California. In regions where waters are silty or brown, such as the coastlines along the Gulf of Mexico, background turbidity levels reach and may exceed 600 NTU.

Present capabilities to monitor turbidity include sampling water clarity through collection of Secchi disk depths, manually sampling the medium and measuring turbidity with a portable turbidimeter, or measuring beam attenuation through use of a transmissometer. Turbidity measurements collected through these sampling methods are sporadic and inconsistent. They do not provide background or project turbidity levels relevant to wind, wave, weather, and seasonal conditions which greatly influence turbidity. Also, these measurements are not representative of extreme turbidity levels since data collection is inhibited during inclement weather conditions.

Quantifying naturally occurring background turbidity levels and turbidity levels which occur throughout coastal operations is difficult due to present measurement methods which limit deployment of instrumentation from a few days to a maximum one-month period. Present measurement methodologies are limited to short-term deployment due to biological fouling of instrumentation and/or limited life of system components. The quantification of turbidity is further complicated by the various methods of measurement and the environmental protection standards for assessing environmental impacts resulting from coastal operations. Present measurement methodologies and water quality standards are applicable in the laboratory environment; however, they are inappropriate for the field environment due to the multitude of factors influencing turbidity in natural waters. In-situ, long-term turbidity measurements are necessary to provide data to determine natural turbidity levels resulting from coastal hydrodynamics, seasonal trends, and meteorological effects. Deviations from naturally occurring turbidity levels due to USACE coastal operations can then be determined from accurate background levels.

The conceptual design of a turbidity monitoring system with the capability to provide in-situ long-term measurements was presented. In-situ, long-term measurements are necessary to quantify temporal variations in turbidity as a function of coastal processes. The turbidity monitoring system may be deployed with other oceanographic instrumentation to simultaneously measure wave conditions, water levels, water temperature, sediment concentration, and additional environmental sensing devices. The turbidity sensing device, a transmissometer, was designed, fabricated, and calibrated to provide turbidity levels, in measurements of beam transmittance, which can be correlated to the legally acceptable units specified by water quality standards.

Laboratory experiments, using formazin solutions, show that the transmissometer can be used to measure turbidity levels ranging from 1 to 900 NTU. The transmissometer provides measurements of beam attenuation. The measurements of beam attenuation were correlated to NTU values by obtaining NTU measurements of the sample using an HF Scientific DRT-100B Research Turbidimeter. The transmissometer was designed with a means to adjust the sensitivity of the instrument. Results of the laboratory experiments show that adjusting the transmissometer sensitivity relative to the expected range of turbidity will increase the accuracy of the measurement.

Experiments were performed to determine if fouling of the transmissometer lenses could be detected and if accurate measurements could be extracted from the fouled system. Fouling was simulated by applying petroleum jelly to the lenses. The data show that this type of system fouling could be detected, and an accurate turbidity measurement could be extracted from the data. Further laboratory testing is necessary to fully evaluate the impacts of various types of fouling to the transmissometer measurements. Testing should include evaluation of impacts due to degradation of system components.

Further investigations are recommended to optimize the transmissometer design and functionality. Recommended modifications to the instrument that may improve accuracy include decreasing the beam width and increasing the pathlength of the beam. Tests should also be conducted to determine the accuracy of measurement repeatability. Testing of the instrument response to natural waters should also be conducted to develop an optimal instrument design.

## References

---

- Austin, R. 1974. "Instrumentation Used in Turbidity Measurement," Proceedings of the National Oceanographic Instrumentation Center Turbidity Workshop, May 1974, Washington, D.C., pp.45-73.
- Austin, R., Llewellyn, J.A., Van Haagan, R., Shannon, J., and Pijanowski, B. 1974. Proceedings of the National Oceanographic Instrumentation Center Turbidity Workshop, May 1974, Washington, D.C., pp.1-8.
- Bartz, R., Zaneveld R.J., and Pak, H. 1978. "A Transmissometer for Profiling and Moored Observations in Water," *Proceedings of SPIE - The International Society for Optical Engineering, Ocean Optics V*, Bellingham, WA, Vol. 160, pp.102-108.
- Berger, J. 1974. "Oceanographic Applications of Turbidity," Proceedings of the National Oceanographic Instrumentation Center Turbidity Workshop, May 1974, Washington, D.C., pp.39-43.
- Bodge, K.R 1995. Olsen Associates, Inc. 4438 Herschel Street, Jacksonville, FL, 32210.
- Booth, R.L. 1974. "Intercomparison of the Jackson Candle Turbidity Measurement and Several Instrumental Techniques," Proceedings of the National Oceanographic Instrumentation Center Turbidity Workshop, May 1974, Washington, D.C., pp.101-105.
- Brown, E., Skougstad, M.W., and Fishman, M.J 1970. "Methods for Collection and Analysis of Water Samples for Dissolved Minerals and Gases: U.S. Geological Survey Techniques Water-Resources Inv.," Book 5, Chapter A1.
- Brown, W.M. III, and Ritter, J.R. 1971. "Sediment Transport and Turbidity in the Eel River Basin, CA," U.S. Geological Survey Water-Supply Paper 1986.
- Buckley, L., and O'Neil, T. 1994. "Final Report - 1994 Grunion Monitoring Project at Santa Barbara Harbor, Santa Barbara, California," U.S. Army Corps of Engineers, Los Angeles, CA, Contract #DACW-09-94-M-0328.

D&A Instruments 1989. "Optical Methods for Measuring Turbidity and Suspended Particles in Water," Technote (3/89).

Eisberg, R.M. and Lerner, L.S. 1981. *Physics: Foundations and Applications*, McGraw-Hill Inc., New York, NY.

FWPCA (Federal Water Pollution Control administration) 1968. "Water Quality Criteria," US Government Printing Office, Washington, D.C., 234pp.

Gordon, H.R., Smith, R.C., and Zaneveld, J.R. 1984. "Introduction to Ocean Optics," *Proceedings of SPIE - The International Society for Optical Engineering, Ocean Optics VII*, Vol. 489, 25-28 June 1984, Monterey, CA.

Hach, C.C. 1992. "Turbidity Standards," Technical Information Series - Booklet No. 12, Hach Company, Loveland, CO, 9pp.

Hach, C.C., Vanous, R.D., and Heer, J.H. 1990. "Understanding Turbidity Measurement," Technical Information Series - Booklet No. 11, Hach Company, Loveland, CO, 11pp.

Hanes, D.M. 1994. "Turbidity and Suspended Sediment Associated With Beach Nourishment Dredging," *Proceedings, 1994 Coastal Engineering Conference*, American Society of Civil Engineers, Chapter 217, pp.3016-3029.

Hauch, R. 1995. US Army Engineer District, Galveston, Jadwin Bldg., PO Box 1229, 200 Fort Point Rd., Galveston, TX, 77553-1229.

Hetrick D. 1974. "A Return to Accurate Turbidity Measurement," *Proceedings of the National Oceanographic Instrumentation Center Turbidity Workshop*, May 1974, Washington, D.C., pp.185-208.

HF Scientific, Inc. 1992. *Water Testing Catalog Bulletin No. WTC/92/US*.

Howell, G.L. 1993a. *Disclosure of Invention*.

Howell, G.L. 1993b. "Design of an In-Situ Directional Wave Gage for One Year Deployments," *Proceedings, Waves '93 Conference*. American Society of Civil Engineers, New Orleans, LA.

Jerlov, N.G. 1976. *Marine Optics*, Elsevier/North-Holland, Inc., New York, NY.

Kirk, J.T. 1994. *Light and Photosynthesis in Aquatic Ecosystems*, Cambridge University Press, New York, NY.

Koeppen, J. 1974. "Turbidity Measurements - An Overview," *Proceedings of the National Oceanographic Instrumentation Center Turbidity Workshop*, May 1974, Washington, D.C., pp.11-15.

Larcombe, P. and Ridd, P.V. 1994. "Dry Season Hydrodynamics and Sediment Transport in a Mangrove Creek," American Geophysical Union.

McCarthy, J.C., Pyle, T.E., and Griffin, G.M. 1974. "Light Transmissivity, Suspended Sediments and the Legal Definition of Turbidity," Estuarine and Coastal Marine Science (1974) Vol 2, pp. 291-299.

McLellan, N. 1995. US Army Engineer District, Galveston, Jadwin Bldg., PO Box 1229, 200 Fort Point Rd., Galveston, TX, 77553-1229.

Mie, G. 1908. Beitrage zur optik truber medien, speziell kolloidalen metall losungen. Ann. Physik.

O'Shea, D.C. 1985. *Elements of Modern Optical Design*, John Wiley & Sons, Inc., New York, NY.

Pequegant, W.E., Gaille, R.S., and Pequegant, L.H. 1967. "Biofouling Studies Off Panama City, Florida II. The Two-Mile Offshore Station," Texas A&M Research Foundation, A&M Project 286-6, Reference 67-18T.

Petzold, T.J. 1972. "Volume Scattering Functions for Selected Ocean Waters," University of California, San Diego, Scripps Institution of Oceanography Visibility Laboratory, SIO Reference 72-28.

Petzold, T.J., and Austin, R.W. 1968. "An Underwater Transmissometer for Ocean Survey Work," University of California, San Diego, Scripps Institution of Oceanography Visibility Laboratory, SIO Reference 68-9.

Rainwater, F.H., and Thatcher, L.L. 1960. "Methods for Collection and Analysis of Water Samples," U.S. Geological Survey Water-Supply Paper 1454.

Rees, S. 1995. US Army Engineer District, Mobile, 109 St. Joseph St., PO Box 2288, Mobile, AL, 36638-0001.

Ridd, P. and Larcombe, P. 1994. "Biofouling Control for Optical Backscatter Suspended Sediment Sensors," Marine Geology Vol. 116, pp.255-258.

Risko, A.J. 1995. US Army Engineer District, Los Angeles, 300 North Los Angeles St., PO Box 2711, Los Angeles, CA, 90053-2325.

Ritter, J.R., and Ott, A.N. 1974. "Measurement of Turbidity by the Geological Survey," Proceedings of the National Oceanographic Instrumentation Center Turbidity Workshop, May 1974, Washington, D.C., pp.23-29.

Schmidt, D. 1994. US Army Engineer District, Jacksonville, 400 West Bay St., PO Box 4970, Jacksonville, FL, 32232-0019.

Standard Methods for the Analysis of Water and Waste Water 1971. American Public Health Association, New York, 13<sup>th</sup> Edition, Chapter 100, pp.349-356.

U. S. Environmental Protection Agency 1979. "Manual for Methods for Chemical Analysis of Water and Wastes: Turbidity, Method 180.1 (Nephelometric) STORET No. 00076," Office of Technology Transfer, Washington, D. C.

USACE Los Angeles District 1990. "Dredging Related Turbidity Monitoring Report Oceanside Harbor, San Diego County, California," August 1990.

Wilber, C.G. 1983. *Turbidity and the Aquatic Environment: An Environmental Factor in Fresh and Oceanic Waters*, Thomas Books, Springfield, IL.

Williams, J. 1970. *Optical Properties of the Sea*, United States Naval Institute Series in Oceanography, United States Naval Institute, Annapolis, MD.

Zaneveld, R.J., Spinrad, R.W., and Bartz, R. 1980. "Optical Properties of Turbidity Standards," Proceedings of SPIE - The International Society for Optical Engineering, Ocean Optics VI, Vol. 208. 159-168.

# REPORT DOCUMENTATION PAGE

*Form Approved*  
OMB No. 0704-0188

Public reporting burden for this collection of information is estimated to average 1 hour per response, including the time for reviewing instructions, searching existing data sources, gathering and maintaining the data needed, and completing and reviewing the collection of information. Send comments regarding this burden estimate or any other aspect of this collection of information, including suggestions for reducing this burden, to Washington Headquarters Services, Directorate for Information Operations and Reports, 1215 Jefferson Davis Highway, Suite 1204, Arlington, VA 22202-4302, and to the Office of Management and Budget, Paperwork Reduction Project (0704-0188), Washington, DC 20503.

<b>1. AGENCY USE ONLY (Leave blank)</b>	<b>2. REPORT DATE</b> September 1996	<b>3. REPORT TYPE AND DATES COVERED</b> Final report	
<b>4. TITLE AND SUBTITLE</b> Development and Evaluation of a Prototype Turbidity Sensor for In Situ, Long-Term Measurements		<b>5. FUNDING NUMBERS</b>	
<b>6. AUTHOR(S)</b> Linda S. Lillycrop, Gary L. Howell, Thomas E. White		<b>8. PERFORMING ORGANIZATION REPORT NUMBER</b> Technical Report CERC-96-9	
<b>7. PERFORMING ORGANIZATION NAME(S) AND ADDRESS(ES)</b> U.S. Army Engineer Waterways Experiment Station 3909 Halls Ferry Road, Vicksburg, MS 39180-6199		<b>10. SPONSORING/MONITORING AGENCY REPORT NUMBER</b>	
<b>9. SPONSORING/MONITORING AGENCY NAME(S) AND ADDRESS(ES)</b> U. S. Army Corps of Engineers Washington, DC 20314-1000		<b>11. SUPPLEMENTARY NOTES</b> Available from National Technical Information Service, 5285 Port Royal Road, Springfield, VA 22161.	
<b>12a. DISTRIBUTION/AVAILABILITY STATEMENT</b> Approved for public release; distribution is unlimited.		<b>12b. DISTRIBUTION CODE</b>	
<b>13. ABSTRACT (Maximum 200 words)</b> <p>State and federal regulations require the U.S. Army Corps of Engineers (USACE) to mitigate adverse environmental impacts resulting from increased turbidity levels which occur during coastal operations. Quantifying turbidity levels prior to, during, and after coastal operations is difficult due to existing turbidity measurement technology and water quality standards. Existing methods for turbidity measurement are limited to short-term deployment, which does not include the impacts of seasonal variations, meteorological effects, and storm conditions.</p> <p>A turbidity monitoring system for collecting long-term in situ measurements is currently in the conceptual design phase. A transmissometer, which is the sensing device for turbidity measurement, fabricated, and tested, and is the focus of this report. The design of the transmissometer considers the requirements for successful long-term in situ deployments. The laboratory calibrated prototype sensor provides the basis for the design and development of a long-term operation USACE turbidity monitoring system. The design of the prototype transmissometer and the laboratory tests, calibration, and results are presented.</p>			
<b>14. SUBJECT TERMS</b> Environmental impacts Light absorption Light scattering		Nephelometer Prototype data Transmissometer	Turbidity
		<b>15. NUMBER OF PAGES</b> 58	<b>16. PRICE CODE</b>
<b>17. SECURITY CLASSIFICATION OF REPORT</b> UNCLASSIFIED	<b>18. SECURITY CLASSIFICATION OF THIS PAGE</b> UNCLASSIFIED	<b>19. SECURITY CLASSIFICATION OF ABSTRACT</b>	<b>20. LIMITATION OF ABSTRACT</b>