

CONTRACT SPC-92-4003

Characterization of the lithium/PAN-based polymer electrolytes interface

Final Report (January 1st-December 31st 1992)

DISTRIBUTION STATEMENT B
Approved for public release
Distribution Unlimited

Bruno Scrosati
Dipartimento di Chimica, University of Rome 'La Sapienza'
00185 Rome, Italy

DTIC QUALITY INSPECTED 2

19961113 153

DISCLAIMER NOTICE



THIS DOCUMENT IS BEST QUALITY AVAILABLE. THE COPY FURNISHED TO DTIC CONTAINED A SIGNIFICANT NUMBER OF PAGES WHICH DO NOT REPRODUCE LEGIBLY.

REPORT DOCUMENTATION PAGE

Form Approved OMB No. 0704-0188

Public reporting burden for this collection of information is estimated to average 1 hour per response, including the time for reviewing instructions, searching existing data sources, gathering and maintaining the data needed, and completing and reviewing the collection of information. Send comments regarding this burden estimate or any other aspect of this collection of information, including suggestions for reducing this burden to Washington Headquarters Services, Directorate for Information Operations and Reports, 1215 Jefferson Davis Highway, Suite 1204, Arlington, VA 22202-4302, and to the Office of Management and Budget, Paperwork Reduction Project (0704-0188), Washington, DC 20503.

1. AGENCY USE ONLY (Leave blank)		2. REPORT DATE 31 December 1992	3. REPORT TYPE AND DATES COVERED Final Report, 1 Jan - 31 Dec 1992	
4. TITLE AND SUBTITLE Characterization of the Lithium/PAN-based Polymer Electrolytes Interface			5. FUNDING NUMBERS F6170892W0139	
6. AUTHOR(S) Bruno Scrosati				
7. PERFORMING ORGANIZATION NAME(S) AND ADDRESS(ES) Universita di Roma La Sapienza Dipartimento di Chimica Piazza A. Moro 5 00185 Rome, Italy			8. PERFORMING ORGANIZATION REPORT NUMBER SPC-92-4003	
9. SPONSORING/MONITORING AGENCY NAME(S) AND ADDRESS(ES) EOARD PSC 802 BOX 14 FPO 09499-0200			10. SPONSORING/MONITORING AGENCY REPORT NUMBER SPC-92-4003	
11. SUPPLEMENTARY NOTES				
12a. DISTRIBUTION/AVAILABILITY STATEMENT Unlimited			12b. DISTRIBUTION CODE	
13. ABSTRACT (Maximum 200 words) Polymers having transport almost exclusively of the ionic type, often named "polymer electrolytes" or, in a broader way, "polymer ionics," have attracted large scientific and technological interest. Research on this new class of electroactive polymers has been very active and substantial progress has been achieved in recent years. Of particular interest are the new generation polymer electrolytes formed by the immobilization into a polymer matrix of common solutions of lithium salts in liquid, organic solvents. These new class of "gel" electrolytes offer very high ambient and subambient conductivities and in this project we have carried out a preliminary investigation of the electrochemical properties of a typical example, namely of the membrane electrolyte obtained by gelification into a polyacrylonite (PAN) matrix of solutions of lithium salts (e.g., LiClO ₄) in aprotic solvents (e.g., an ethylene carbonate-propylene carbonate mixture). The choice was motivated by the fact that membranes of this type appears to be closest to reach a practical exploitation.				
14. SUBJECT TERMS			15. NUMBER OF PAGES 20	
			16. PRICE CODE	
17. SECURITY CLASSIFICATION OF REPORT UNCLASSIFIED	18. SECURITY CLASSIFICATION OF THIS PAGE UNCLASSIFIED	19. SECURITY CLASSIFICATION OF ABSTRACT UNCLASSIFIED	20. LIMITATION OF ABSTRACT UL	

Characterization of the lithium/PAN-based polymer electrolytes interface

ABSTRACT

Polymers having transport almost exclusively of the ionic type, often named "polymer electrolytes" or, in a broader way, "polymer ionics", have attracted large scientific and technological interest. Research on this new class of electroactive polymers has been very active and substantial progress has been achieved in recent years. Of particular interest are the new generation polymer electrolytes formed by the immobilization into a polymer matrix of common solutions of lithium salts in liquid, organic solvents. These new class of 'gel' electrolytes offer very high ambient and subambient conductivities and in this Project we have carried out a preliminary investigation of the electrochemical properties of a typical example, namely of the membrane electrolyte obtained by gelification into a polyacrylonitrile (PAN) matrix of solutions of lithium salts (e.g., LiClO_4) in aprotic solvents (e.g., an ethylene carbonate-propylene carbonate mixture). The choice was motivated by the fact that membranes of this type appears to be closest to reach a practical exploitation.

INTRODUCTION

Polymers having transport almost exclusively of the ionic type, often named "polymer electrolytes" or, in a broader way, "polymer ionics", have attracted large scientific and technological interest. Research on this new class of electroactive polymers has been very active and substantial progress has been achieved in recent years.

In the most classical definition, polymer electrolytes may be described as polar macromolecular solids in which a wide range of salts may be dissolved (1). These materials can be easily fabricated into flexible, thin films with large surface area where the ions are free to move and can conduct the electricity as in conventional liquid electrolytes. The practical relevance of this property was

rapidly recognized and in a few years the field expanded tremendously with the involvement of a constantly increasing number of academic and industrial laboratories. Following this diversified research activity, the mechanism of ionic transport has been established (1) and this has led to the development of new host polymers of various types (2), containing new salts (3) and having advanced polymer architectures. These achievements have enabled room temperature conductivity to be raised by several orders of magnitude (4).

Indeed, the characterization of thin film, polymer membranes which can act both as electrode separator and as a medium for ionic transport, has opened the challenging possibility of fabrication of new electrochemical devices with revolutionary designs. Particularly relevant in this respect is the development of rechargeable, thin-film lithium batteries designed for the replacement of conventional systems, such as lead-acid or nickel-zinc, for important applications in the electric vehicle and in the consumer electronics area. However, lithium polymer batteries can be considered effective alternatives to more conventional power sources only if they are capable of comparable diversification, especially in terms of operation temperature. This explains the large effort devoted in the latest years for the development of electrolytic membranes having high conductivity at ambient and subambient temperature.

From the initial, *first generation* electrolytes based on the 'simple' combination of high molecular weight polymer hosts (e.g. poly(ethylene oxide), PEO) and lithium salts (e.g. LiX) having conductivity of 10^{-4} S cm $^{-1}$ at 100 °C (5), the development in the area has first resulted in the production of *second generation* electrolytes-based on the combination of modified, comb-shaped PEO structures (e.g. short ethylene oxide side chains attached to supporting inactive backbone chains) with lithium salts- having conductivity of the order of 10^{-5} - 10^{-5} S cm $^{-1}$ at room temperature (6) and, more recently, of *third generation* electrolytes formed by the addition of plasticizers and cross-linking agents to 'common' PEO-LiX complexes, as well as by trapping in a gel matrix liquid solutions of lithium salts, both systems having conductivity as high as 10^{-3} S cm $^{-1}$ at ambient and subambient temperatures (4).

These third generation electrolytes appear of particular interest since they offer a conductivity comparable to that of the liquid solutions commonly used for the fabrication of commercial lithium batteries. Although relevant attention has been devoted to the area of the so called 'gel electrolytes', a systematic electrochemical characterization of this type of ionic polymers is still lacking. It has therefore appeared of importance to attempt to fill this gap by investigating the bulk and interfacial properties of these new class of materials. In this report, we describe results obtained within a Research Project focused on the system formed by gelling a solution of lithium salts in aprotic solvents (e.g., LiClO $_4$ in a ethylene carbonate-propylene carbonate mixture) into a polyacrylonitrile (PAN) matrix. The choice has been motivated by the fact that electrolytic membranes of this type, which were originally described by Abraham and co-workers (4, 7-9) appears to be the closest for practical exploitation.

EXPERIMENTAL

The composition of the electrolytic membrane was that originally suggested by Abraham and Alamgir (7), namely the following (in mole ratio): polyacrylonitrile (PAN): 21; lithium perchlorate (LiClO_4): 8 ethylene carbonate (EC):38; and propylene carbonate (PC):33.

The purification of the chemical products is an important step to assure the reliability of the final material and thus the consistency of its characterization tests. With this in mind, we have further purified the commercial PAN (Aldrich, reagent grade) by drying it under vacuum at 80 °C. Care was taken in maintaining the annealing temperature below 100 °C in order to avoid PAN decomposition. Propylene carbonate (Fluka reagent grade) was purified by distillation under reduced pressure. Solid reagent grade ethylene carbonate (Fluka reagent grade) was mixed in the desired proportion with propylene carbonate and the resulting EC-PC liquid mixture was dried by storing it over molecular sieves. LiClO_4 (a Fluka extra product) was used as received.

Particular attention was devoted to the preparation of the final electrolytic membrane. In fact, it was readily found out that the proper preparation method involves some crucial steps and that successful results could be obtained only if these steps are approached and performed with great accuracy. The most critical of these steps is the achievement of the complete reciprocal dissolution of the electrolyte components to obtain a clear liquid phase. To fulfill this condition, it is necessary to first dissolve the LiClO_4 salt in the EC-PC solvent mixture, to heat the resulting solution to 100 °C and then gradually and slowly add powdered PAN, keeping the solution under continuous stirring.

One has to point out that the achievement of a totally clear liquid phase, which is an essential condition to assure the homogeneity of the final electrolytic membrane, was obtained only when PAN was added in the form of a fine grain size powder. We have fulfilled this requirement by fracturing the purified PAN commercial product. Another important factor in this delicate preparation method is the value of the dissolution temperature which, to prevent PAN decomposition, should never exceed 100 °C.

To obtain the desired type of membrane and to control their final thickness, the vial containing the mixture was placed in a preheated silicon bath at 100 °C until a clear viscous gel formed. Films were formed by slowly casting the hot gel between two glass plates, with spacers to control the thickness. When all these conditions were fulfilled, solid membranes, which generally had a translucent, elastomeric appearance, were obtained. Figure 1 shows the appearance of a typical example of these membranes.

The bulk properties of the gel electrolyte membranes were evaluated by measuring the ionic conductivity. Of particular interest in this project was the clarification of the properties of the lithium electrode/ gel electrolyte interface. This was performed by cyclic voltammetry and impedance analysis.

The conductivity measurements were performed by running impedance spectroscopy on cells formed by comprising the electrolyte samples between two plane, metallographic-grade polished, parallel stainless steel (SS) electrodes. Assuming an ionic transport mainly due to Li^+ ions, the stainless steel electrodes

have an ionically 'blocking' nature, so that the resistance of the cells may be obtained on the basis of the standard impedance procedure, namely by the intercept on the real axis of $-jZ'' - Z'$ plots. These plots were obtained with a Solartron 1255 frequency response analyzer (frequency range 10^{-2} - 10^5 Hz) coupled with a Solartron 1286 electrochemical interface, all the instrumentation being controlled by an IBM-70 PC.

To obtain consistent conductivity data from the resistance measurements, it is essential to have a precise value of the cell constant, namely the value of the electrode surface and of their reciprocal distance. This has been obtained by equipping the cell with anular spacers, having fixed diameter and thickness, into which the electrolyte samples could be accomodated. Figure 2 shows a schematic diagram of the conductivity cell. The spacers are absolutely necessary to assure reliable results since the PAN-based gel electrolyte are soft and thus they could otherwise be squeezed differently according to different applied pressure or temperature.

However, even using our controlled-geometry cell, the conductivity data may still be affected by a certain error, since there is always the possibility that a small part of the sample overflows between spacers and electrodes, thus making uncertain the value of the distance between the electrodes. We estimate that this error should not exceed 10% of the reported conductivity data.

The kinetics of the lithium deposition-stripping process from cells using the selected gel electrolyte, were investigated by cyclic voltametry. The tests were run using a PAR potentiostat Mod. 273 and stored and recorded using a M270 software.

The characteristics of the lithium electrode / gel membrane eletrolyte interface were investigated by monitoring the evolution of the a.c. impedance responses of symmetrical cells of Li/polymeric membrane /Li type, stored at room temperature under open circuit conditions for several days. Occasionally, current pulses, ranging from $25 \mu\text{Acm}^{-2}$ to 1.4mAcm^{-2} , were passed through the cell with the aim of detecting disruption of the passivating layers. The cell, having a geometry similar that used for the conductivity studies, had two plane, metallographic-grade polished, parallel stainless steel current collectors, which were kept under constant mechanical pressure by using calibrated spring-loaded terminals. For this investigation lithium metal (Foote Mineral Co. pure compound) was used. In order to obtain electrodes with a "clean" surface, i.e. with a surface as free as possible from native films, lithium was scraped to metallic luster in an argon-filled dry box. The impedance parameters were obtained with the same instrumentation used for the conductivity measurements. The assemblage of the cells and all their tests were carried out in an argon-filled dry box (less than 10 p.p.m. moisture content).

RESULTS AND DISCUSSION

1. Conductivity and electrochemical stability.

The first concern of this Project was to confirm that the selected 38%EC/33%PC/21%PAN/8% LiClO₄ membrane, that we can simply indicate as LiClO₄-PC/EC-PAN, is indeed a highly conducting electrolyte. Therefore, particular care was devoted to the measurement of the specific resistivity, obtained by analyzing the 'JZ'-Z' impedance plots of 'blocking' cells of the SS/ LiClO₄-PC/EC-PAN / SS type (SS=stainless steel). Figure 3 illustrates a typical example of these plots. As is well established (10), the bulk resistance of the electrolyte may be evaluated by the intercept with the real Z axis. The correct value of the intercept may be obtained by treating the experimental data with suitable fitting programs. We have used the NLLSQ program written by Boukamp (11).

With these considerations in mind, we have proceeded to the measurement of the conductivity of the LiClO₄-PC/EC-PAN electrolyte over a temperature range of practical interest, namely between -20°C and 50°C. Figure 4 shows the resulting Arrhenius plot: the white-dot line refers to the first heating scan, while the black-dot lines refer to the following cooling and heating scans. The reproducibility between the data subsequent to the first scan indicated that the cell had reached the steady conditions and thus the reliability of the conductivity curve. These curves show that the LiClO₄-PC/EC-PAN system is indeed a highly conductive electrolyte, thus confirming the data reported in the literature (4,7).

However, the high conductivity is maintained only when the electrolyte is kept in a tightly closed environment. This is shown by Figure 5 which compares the changes in resistance of the electrolyte when measured in a sealed cell and when measured in a cell maintained open in the dry box. One can clearly see that in the former case the resistance remains constant over a period of 20 days, while in the latter case it constantly increases. We have attributed this instability to the fact that under open conditions there is a progressive evaporation of the liquid (mostly PC) solvents, thus increasing the viscosity of the electrolyte with a consequent decay in the ionic mobility. This effect, which, to our knowledge, is here reported for the first time, is crucial in determining the effective conditions of operation of this new polymer electrolyte.

Another crucial parameter in this respect is the electrochemical stability of the LiClO₄-PC/EC-PAN electrolyte. We have determined this parameter by running a sweep voltammetry of a SS electrode and measuring the current evolution. The results, illustrated in Figure 6, show that the electrolyte has a large window, exceeding 4.5 V vs. Li. This wide electrochemical stability is a favourable characteristic since it allows the use of high voltage electrode couples, such as the Li-LiMO₂ (M=Co, Ni,...) ones.

2. Lithium deposition-stripping process.

The kinetics of the lithium deposition-stripping process:



on a stainless steel substrate from LiClO_4 -PC/EC-PAN electrolyte cells, was investigated by cyclic voltammetry. Figure 7 illustrates a typical result related to the initial cycles: one can clearly see that the cathodic scan develops with a single deposition peak which is reflected in the anodic scan by a single stripping peak. The peak definition is good and the peak area are comparable. All these evidences suggest that process [1] is reversible and characterized by fast kinetics.

However, the results of Figure 7 refer to a freshly made cell and thus, they are representative of the initial behavior of the lithium electrode. To investigate the properties of this electrode on a prolonged time scale we have monitored the related voltammetry curves over a repeating number of cycles. Figure 8 shows the response of the 1st, 12th, 22th, and 62th cycles of the Li deposition-stripping process on a SS substrate from a cell aged for one day. Some new effects are evident: i) the original single anodic stripping peak tends to split in two peaks; ii) the reversibility of the process (as expressed by the definition and the separation of the peaks) tends to deteriorate upon cycling. The latter effect is indicative of a progressive deterioration of the interface, possibly due to passivation phenomena (see next session).. The former effect is unclear: in fact, it is difficult to explain a two peaks-trend for the stripping process, unless assuming a formation of an intermetallic compound between the deposited lithium and the substrate.

3. Stability of the Li/ LiClO_4 -PC/EC-PAN electrolyte interface.

High conductivity, controlled chemical stability, and a wide electrochemical window, although appreciable properties, are not sufficient to make an electrolyte successful in practical terms. The compatibility with the electrode materials is also an essential parameter to guarantee acceptable performance in devices (such as batteries) especially in terms of cyclability and reliability. The stability of the Li / LiClO_4 -PC/EC-PAN electrolyte has been evaluated by impedance analysis. Figure 9 illustrates the impedance responses of a Li/ LiClO_4 -PC/EC-PAN electrolyte /Li cell at progressive times of storage under open circuit conditions. The result clearly reveals a progressive expansion of the middle frequency semicircle. This expansion is quite likely associated to a continuous growth of a resistive layer on the Li electrode surface. This in turn indicates that the lithium electrode is readily passivated when in contact with the LiClO_4 -PC/EC-PAN electrolyte. On the other hand this behavior, which has also been observed in other laboratories (9), is not surprising since some of the electrolyte components (i.e. EC and PC) are well known lithium corrosive agents. As discussed above, these components spontaneously evaporate from the bulk of the gel electrolyte.

Therefore, it is reasonable to suppose that the solvents, and PC in particularly, continuously reach the interfaces inducing the observed passivation effects.

With the aim of further clarifying the lithium passivation mechanism, we have attempted to determine the impedance parameters which are relevant for the interpretation of the interfacial phenomena. This operation requires the identification of a suitable equivalent circuit which could represent the electrical analogue of the Li/ LiClO₄-PC/EC-PAN electrolyte interface. We selected the circuit shown in Figure 10, where the most relevant constituent is the series of the two RC parallel networks. The network 4-5 describes the charge transfer kinetics while the network 5-6 accounts for the mass-transport kinetics. The electrical parameters related to the lithium passivation film are element 3 (film resistance) and element 2 (film capacitance).

The selected equivalent circuit was used to fit the experimental data and thus to obtain the impedance parameters relevant for the interface under study. Figure 11 illustrates the time evolution of the film resistance and of the charge transfer resistance obtained by the fitting procedure. It is clearly seen that both parameters steadily increase with time, thus confirming that the passivation of the lithium electrode is a continuous process in the LiClO₄-PC/EC-PAN electrolyte. The passivation induces the growth of a resistive layer which blocks the electrochemical process at the interface and, consequently, the charge transfer resistance increases. These results suggest that the very appealing high conductivity of the LiClO₄-PC/EC-PAN electrolyte may be somewhat contrasted by the reactivity towards the lithium electrode. This poses some major questions as to the effective applicability of this electrolyte.

CONCLUSIONS

The results obtained in this project suggest that the LiClO₄-PC/EC-PAN gel is a highly conductive polymer electrolyte of potential application for the realization of versatile electrochemical devices (e.g., lithium batteries, electrochromic devices, sensors). However, the applicability of this electrolyte is still affected by the poor compatibility with the lithium electrode. Results obtained in the course of this Project and also in other laboratories, clearly show that the lithium metal electrode readily passivates when placed in contact with the LiClO₄-PC/EC-PAN electrolyte.

Further work is recommended for an understanding of the impact that this new class of polymer electrolytes may have on future electrochemical technology. Possible lines of research are:

- 1) Further investigation of the lithium passivation phenomena in the LiClO₄-PC/EC-PAN and similar gel electrolytes with the goal of determining the most suitable actions for controlling their nature and extent.
- 2) Investigation of the cyclability of 'complete' lithium cells (e.g., Li/LiMO₂ cells, where M=Co, Ni, ...) with the aim of determining the 'effective' role of the passivation phenomena during repeated charge-discharge processes.

3) Fabrication and test of 'lithium-free' battery configurations (e.g., Li_xC_6 /gel electrolyte/ LiMO_2 rocking chair cells) where passivation is overcome by avoiding lithium plating. Due to their wide stability window, the PAN- based electrolytes appear particularly suitable for this type of cells.

4) Development and characterization of gel electrolytes based on other polymers (e.g. in alternative to PAN) or of other lithium salts (e.g. in alternative to LiClO_4) or on other solvents (e.g., in alternative to EC and PC), with the aim of identifying systems with improved stability towards lithium.

REFERENCES.

1. "Polymer Electrolyte Review 1", J.R.MacCallum & C.A.Vincent Eds., Elsevier Applied Science, London, 1987 ..
2. F.M.Gray, "Solid Polymer Electrolytes", VCH Pu. , Cambridge, UK, 1991
3. G.C. Farrington and R.Linford , ' Poly(ethylene oxide) Electrolytes Containing Divant Cations, in "Polymer Electrolyte Review 2", J.R.MacCallum & C.A.Vincent Eds., Elsevier Applied Science, London, 1989.
4. K.M. Abraham, ".Polymers for Development of highly-conducting Electrolytes" in 'Applications of Electroactive Polymers', B.Scrosati Ed., Chapman & Hall, London, 1993.
5. M.Armand, *Advanced Mat.*, 2 (1990) 278.
6. M.Andrei, L.Marchese, A.Roggero, S.Passerini and B.Scrosati , 'Second International Symposium on Polymer Electrolytes', B.Scrosati Ed., Elsevier Applied Science, London, 1990, pag 107.
7. K.M.Abraham and M.J.Alamgir, *J.Electrochem. Soc.*, 136 (1990) 1657.
8. K.M.Abraham, M.J. Alamgir, G.S.Jones and L.Wu, *Electrochem.Society Fall Meeting*, Phoenix, AZ, Oct. 13-17, 1991, abstr. 691
9. K.M.Abraham and M.Alamgir "*Ambient Temperature Rechargeable Polymer Electrolyte Batteries*" IMLB-6, Munster, Germany, May 10-15, 1992.
10. J. Ross Macdonald, "Impedance Spectroscopy", J. Wiley & Sons, New York, 1987.
11. B.A.Boukamp, *Solid State Ionics*, 20 (1986) 31.

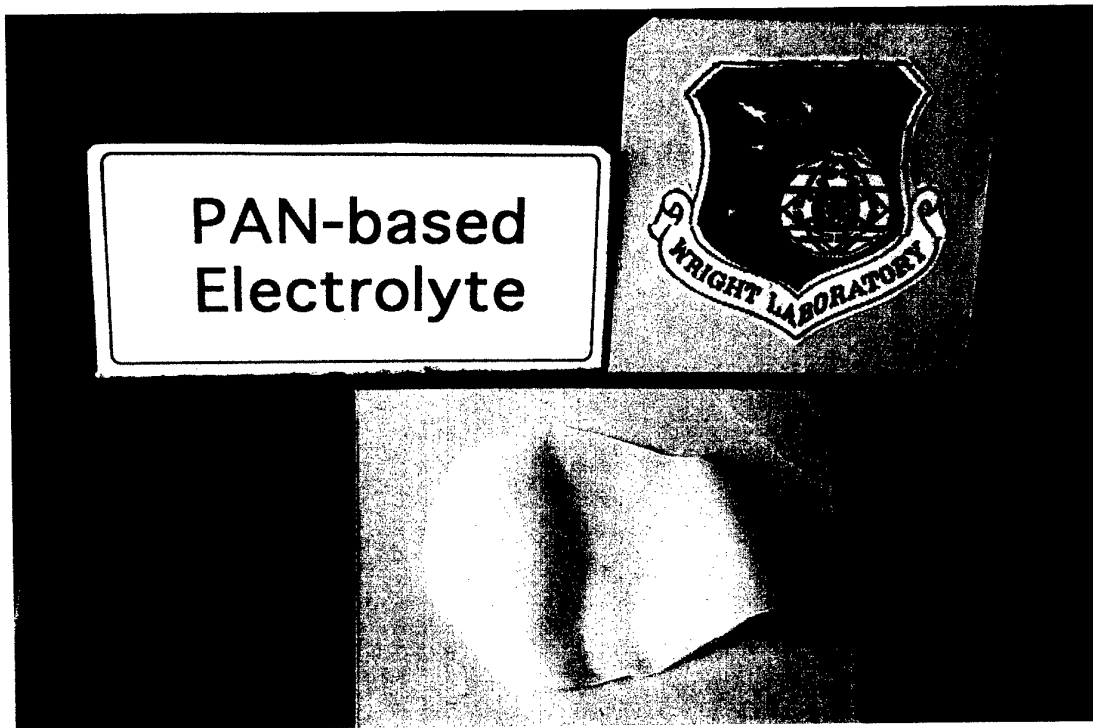

FIGURE 1- Photograph of a typical $\text{LiClO}_4\text{-PC/EC-PAN}$ electrolyte membrane.

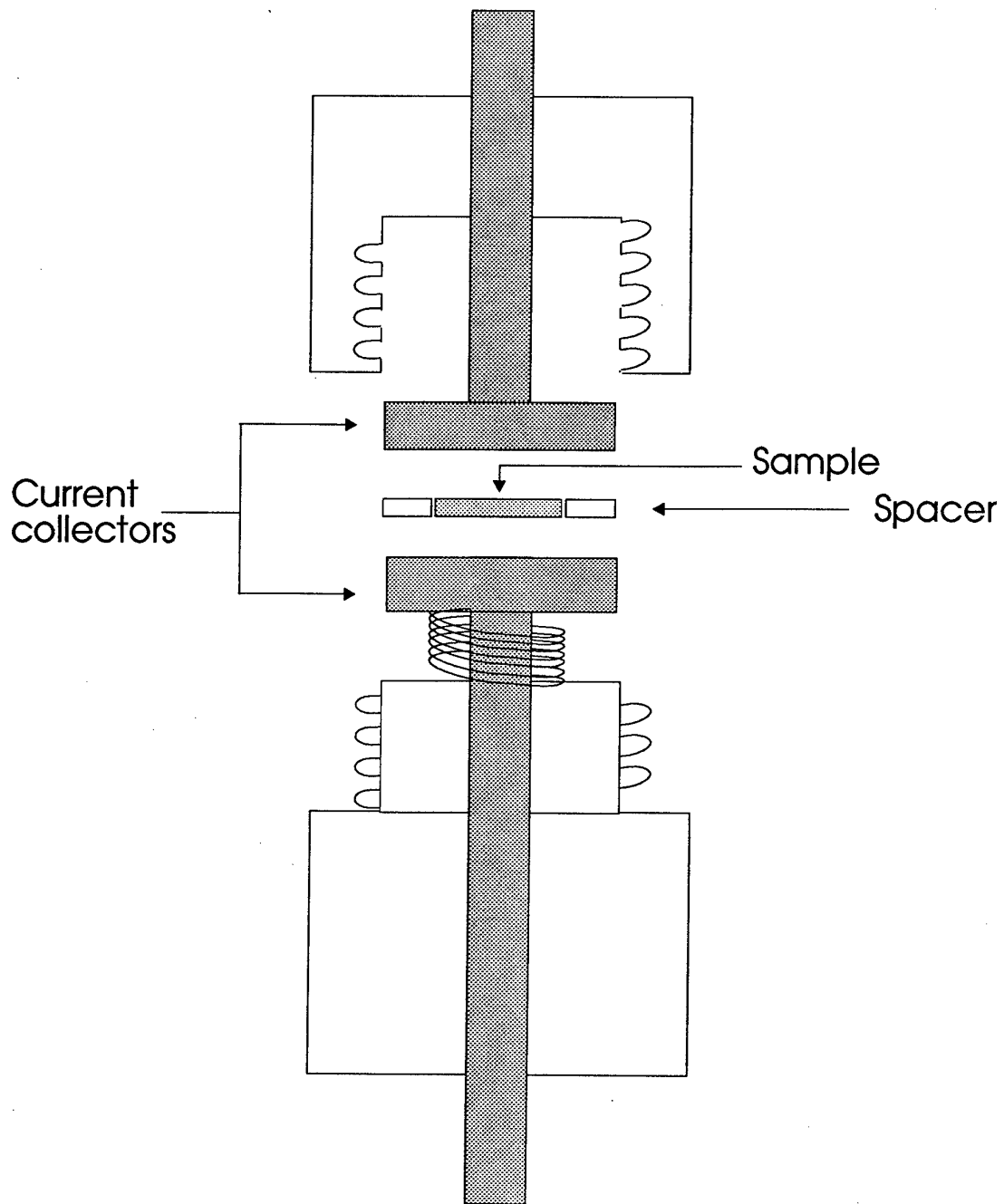

FIGURE 2- Schematic diagram of the conductivity cell.

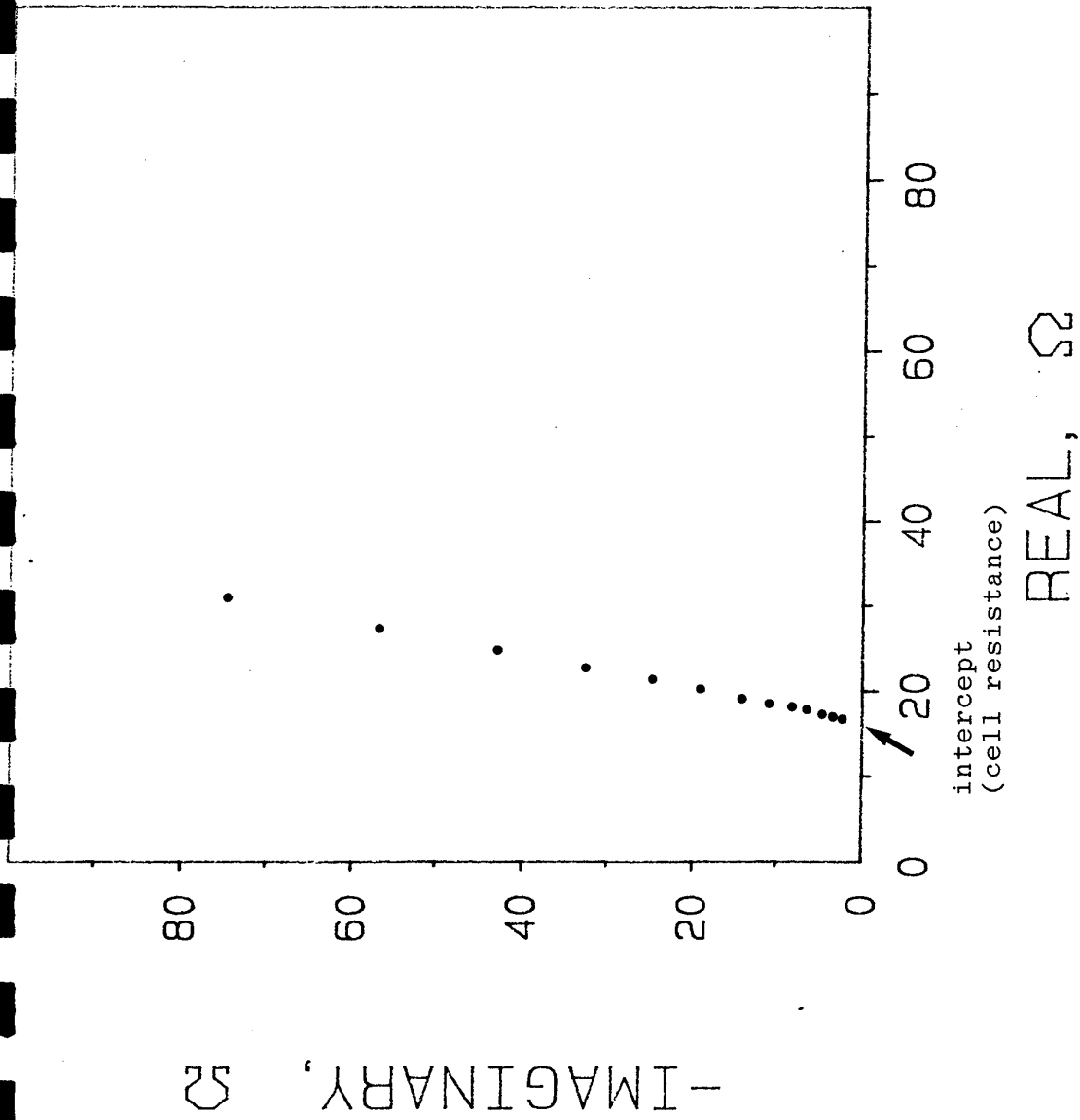

FIGURE 3- Typical impedance plot of a SS/ LiClO₄-PC/EC-PAN /SS cell. Temperature: 49.1 °C. Frequency range: 1Hz-50 kHz. The intercept of the capacitive spike with the real axis 'Z' gives the value of the electrolyte resistance. The correct value is obtained by fitting the data with a suitable program.

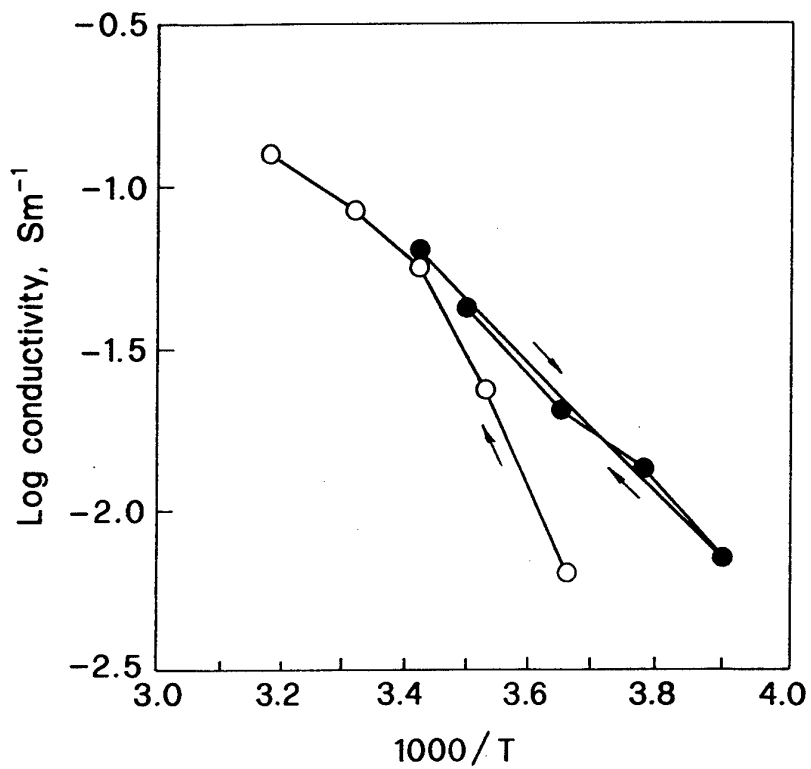

FIGURE 4-Arrhenius plot of the conductivity of the LiClO₄-PC/EC-PAN electrolyte. --O-- : first heating scan; --●--: first cooling and second heating scans.

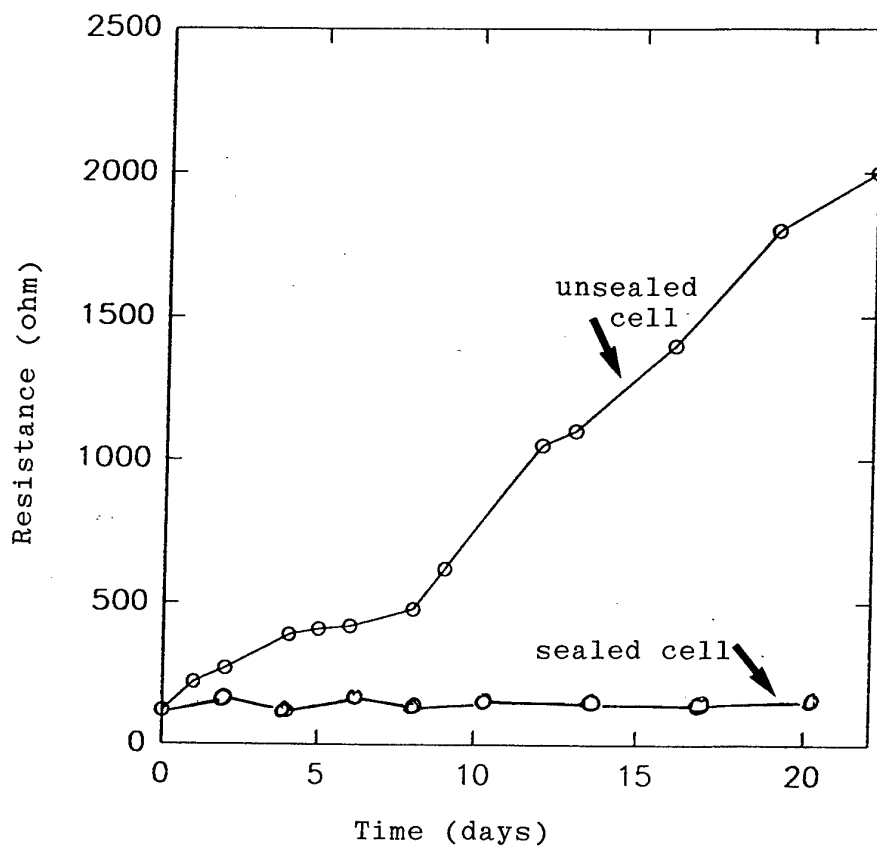

FIGURE 5- Time evolution at room temperature of the resistance of a LiClO_4 -PC/EC-PAN electrolyte measured in sealed and unsealed cells. The measurements were performed using impedance spectroscopy. In both cells, two plane, metallographic-grade polished stainless steel electrodes were used.

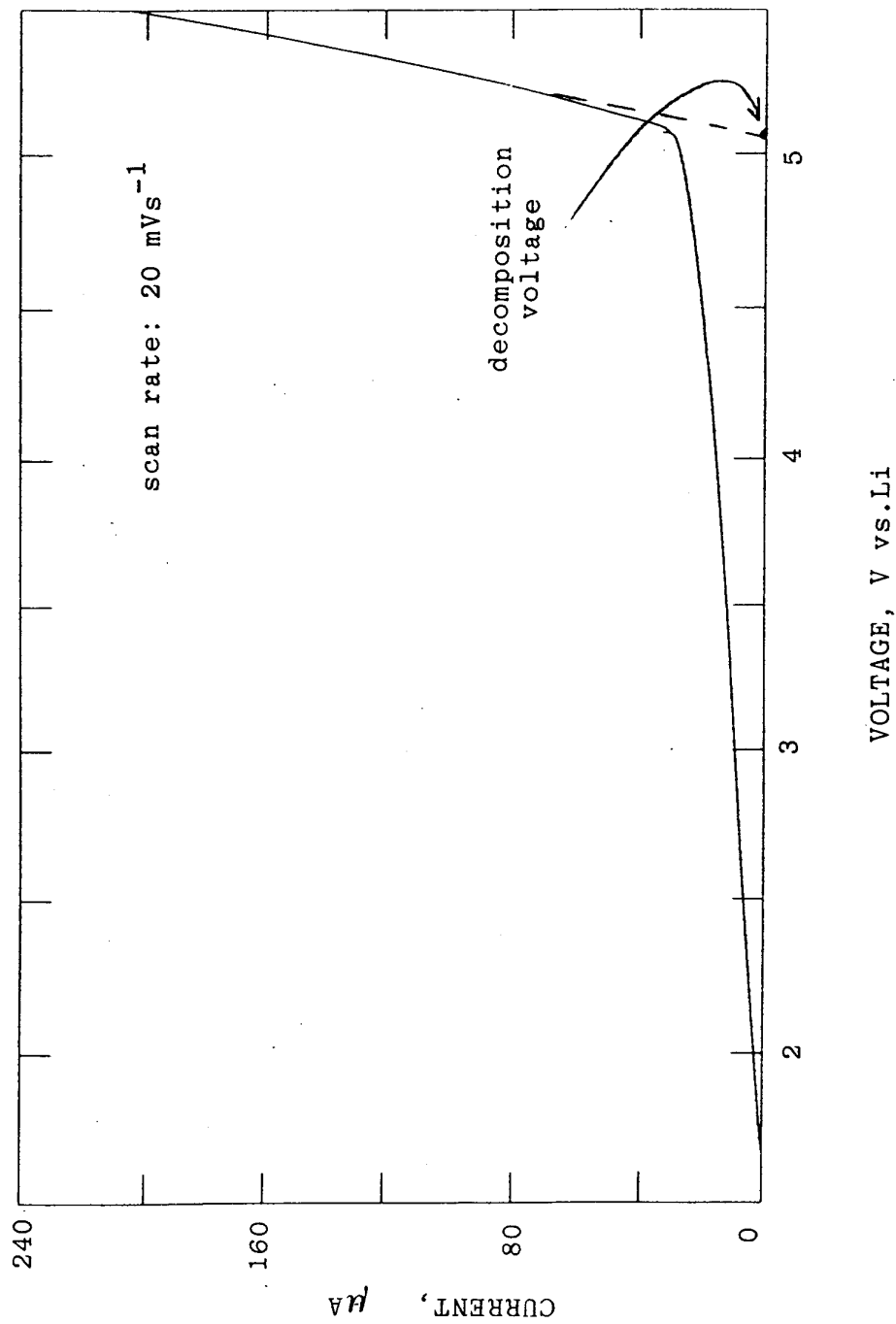

FIGURE 6. Sweep voltammery of a SS electrode in a $\text{LiClO}_4\text{-PC/EC-PAN}$ electrolyte. Room temperature. Lithium reference. 20 mV s^{-1} scan rate. The current flows determine the stability window of the electrolyte, which is comprised between 0 V (lithium deposition) and 4.5V (electrolyte oxidation).

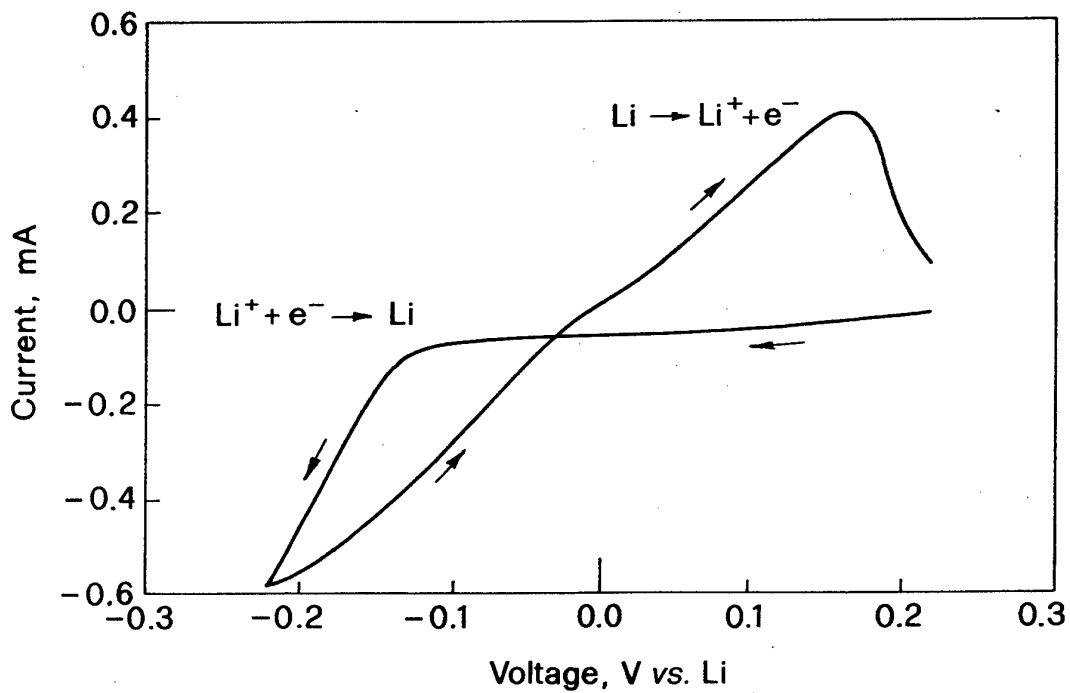

FIGURE 7- Cyclic voltammety of the lithium plating and stripping process from the $\text{LiClO}_4\text{-PC/EC-PAN}$ electrolyte on a SS substrate. Room temperature. Lithium reference. 10 mV s^{-1} scan rate.

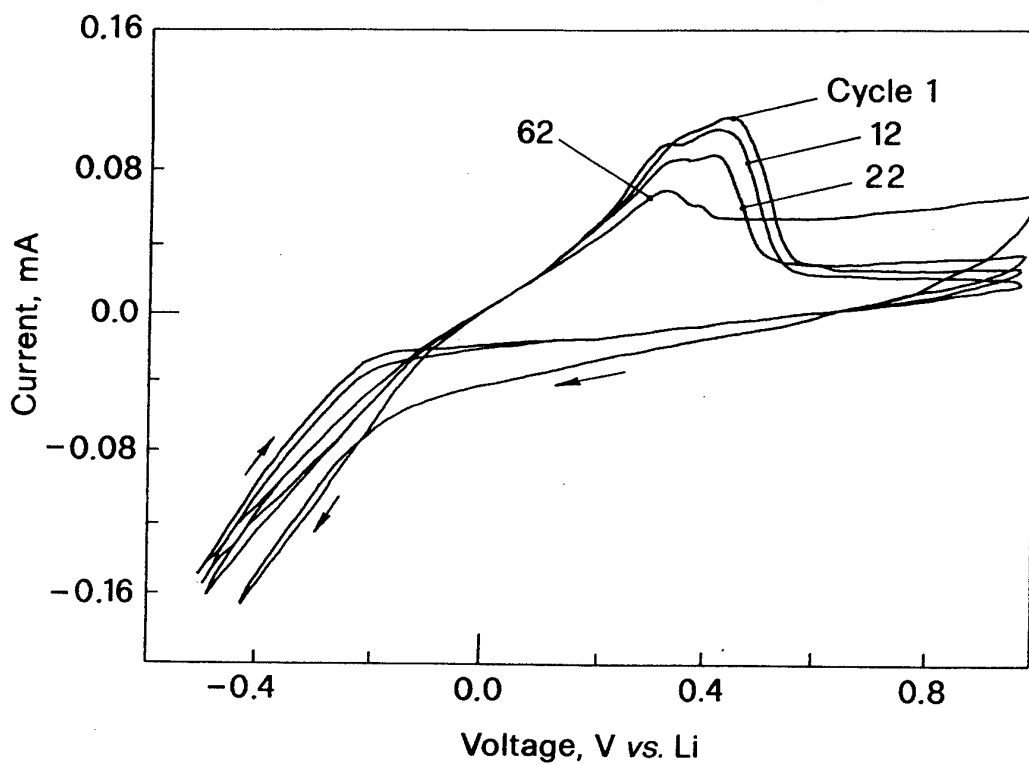

FIGURE 8- Voltammetric response of the 1st, 12th, 22th, and 62th cycles of the Li deposition-stripping process on a SS substrate from a $\text{LiClO}_4\text{-PC/EC-PAN}$ electrolyte cell aged for one day. Room temperature. Lithium reference. 50 mVs^{-1} scan rate

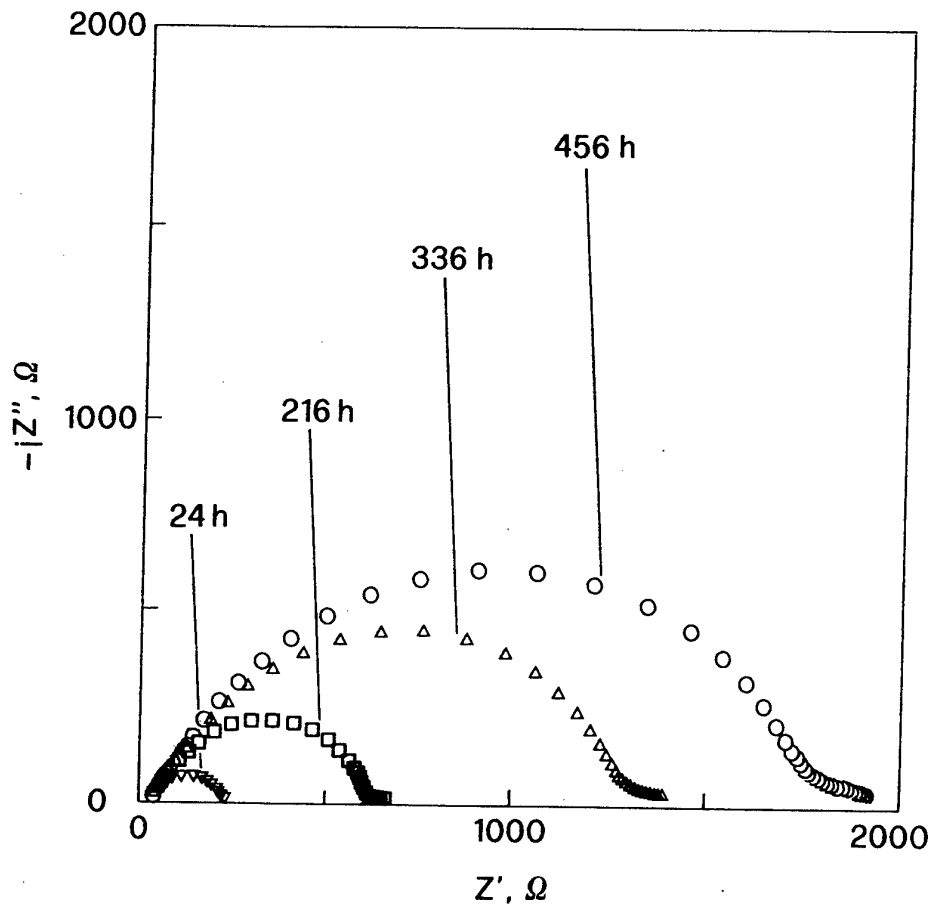
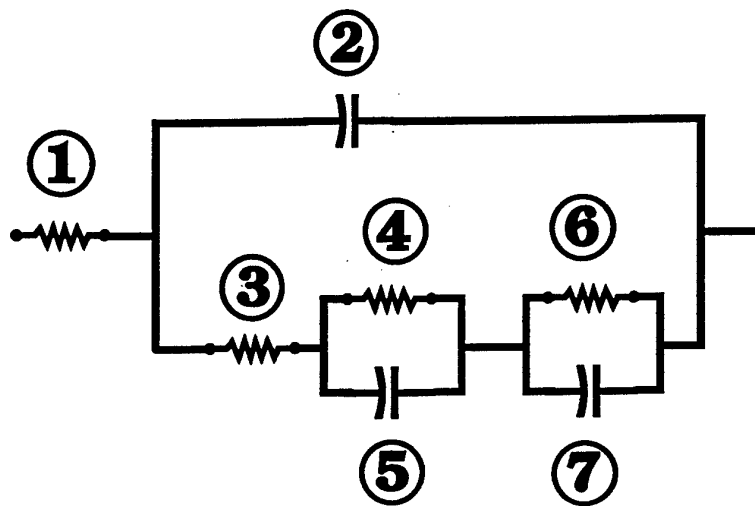

FIGURE 9- Time evolution of the impedance response of a Li/PAN-PC-EC-LiClO₄ /Li cell stored at room temperature under open circuit conditions.



- | | |
|------------|----------------------|
| ① R . bulk | ④ R. charge transfer |
| ② Q. film | ⑤ Q. charge transfer |
| ③ R. film | ⑥ R. diffusion |
| | ⑦ Q. diffusion |

FIGURE 10 - Equivalent circuit representing the lithium/Li/PAN-PC-EC-LiClO₄ electrolyte interface.

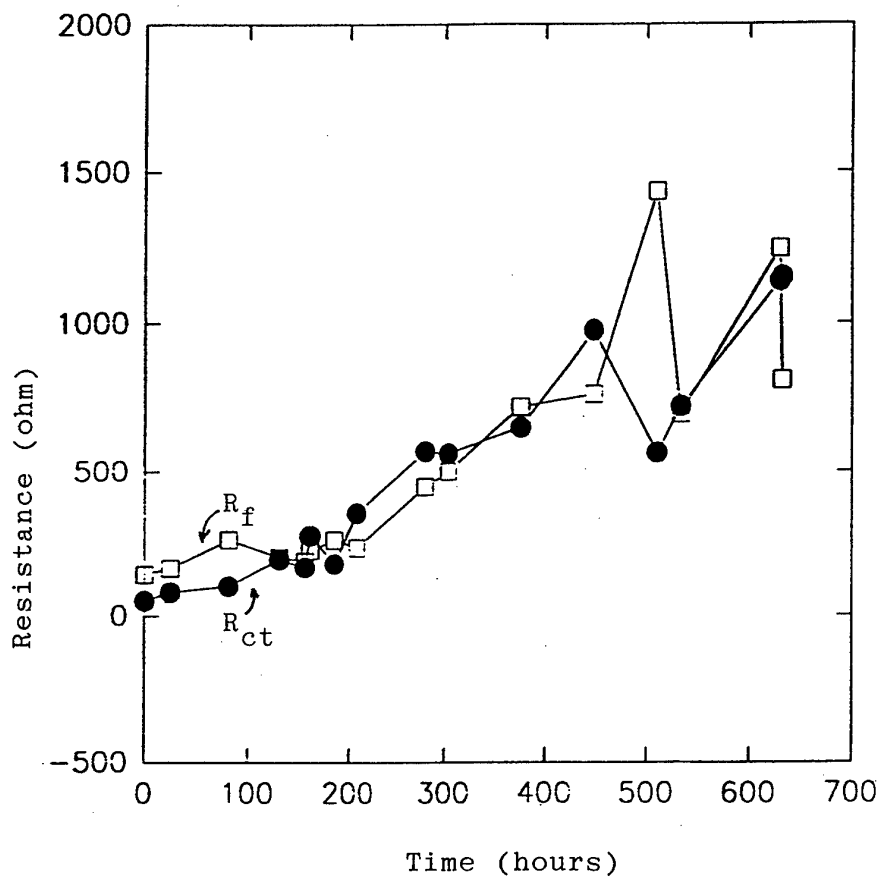

FIGURE 11- Time evolution of the resistance of the passivation film and of the charge transfer resistance of a $\text{Li/LiClO}_4\text{-PC/EC-PAN/Li}$ cell stored at room temperature under open circuit conditions.