

AD _____

CONTRACT NUMBER DAMD17-94-C-4154

TITLE: WRAIR GOCO Blood Research Detachment's Red Blood Cell Storage Laboratory

PRINCIPAL INVESTIGATOR: Lloyd E. Lippert, Ph.D.

CONTRACTING ORGANIZATION: Bionetics Corporation
Hampton, Virginia 23669

REPORT DATE: October 1996

TYPE OF REPORT: Annual

19961202 084

PREPARED FOR: Commander
U.S. Army Medical Research and Materiel Command
Fort Detrick, Frederick, Maryland 21702-5012

DISTRIBUTION STATEMENT: Approved for public release;
distribution unlimited

The views, opinions and/or findings contained in this report are those of the author(s) and should not be construed as an official Department of the Army position, policy or decision unless so designated by other documentation.

DTIC QUALITY INSPECTED 4

REPORT DOCUMENTATION PAGE

Form Approved
OMB No. 0704-0188

Public reporting burden for this collection of information is estimated to average 1 hour per response, including the time for reviewing instructions, searching existing data sources, gathering and maintaining the data needed, and completing and reviewing the collection of information. Send comments regarding this burden estimate or any other aspect of this collection of information, including suggestions for reducing this burden, to Washington Headquarters Services, Directorate for Information Operations and Reports, 1215 Jefferson Davis Highway, Suite 1204, Arlington, VA 22202-4302, and to the Office of Management and Budget, Paperwork Reduction Project (0704-0188), Washington, DC 20503.

1. AGENCY USE ONLY (Leave blank)		2. REPORT DATE October 1996	3. REPORT TYPE AND DATES COVERED Annual (21 Sep 95 - 20 Sep 96)	
4. TITLE AND SUBTITLE WRAIR GOCO Blood Research Detachment's Red Blood Cell Storage Laboratory			5. FUNDING NUMBERS DAMD17-94-C-4154	
6. AUTHOR(S) Lloyd E. Lippert, Ph.D.				
7. PERFORMING ORGANIZATION NAME(S) AND ADDRESS(ES) Bionetics Corporation Hampton, Virginia 23669			8. PERFORMING ORGANIZATION REPORT NUMBER	
9. SPONSORING/MONITORING AGENCY NAME(S) AND ADDRESS(ES) Commander U.S. Army Medical Research and Materiel Command Fort Detrick, Frederick, MD 21702-5012			10. SPONSORING/MONITORING AGENCY REPORT NUMBER	
11. SUPPLEMENTARY NOTES				
12a. DISTRIBUTION / AVAILABILITY STATEMENT Approved for public release; distribution unlimited			12b. DISTRIBUTION CODE	
13. ABSTRACT (Maximum 200) A research laboratory to support red blood cell preservation research was staffed and maintained at the Blood Research Detachment, 1413 Research Boulevard, Rockville, MD 20850. Two clinical trials evaluating candidate red cell preservation systems for eight week red cell storage were initiated. The data collection was completed on the first study; the second is ongoing. A facility to manufacture acellular hemoglobin solutions and a quality control laboratory to support the in-process and product release testing requirements of the production facility were staffed and maintained until 20 September. Six additional hemoglobin production process improvement were instituted which, when combined with previous fiscal year process improvements, increased the purity by 30%, increased yield by 25% and reduced production time. Prior to the production facility closure, 106.04 l of hemoglobin solution containing 11.32 kg hemoglobin was manufactured which met or exceeded contract specifications, two specialty hemoglobin products were produced, liposome encapsulated hemoglobin was prepared, and facility was prepared for indefinite shut-down. The Blood Research Detachment's mission was supported.				
14. SUBJECT TERMS Blood substitutes, acellular hemoglobin solution, Diasprin crosslinked hemoglobin, red blood cell preservation			15. NUMBER OF PAGES 71	
			16. PRICE CODE	
17. SECURITY CLASSIFICATION OF REPORT Unclassified	18. SECURITY CLASSIFICATION OF THIS PAGE Unclassified	19. SECURITY CLASSIFICATION OF ABSTRACT Unclassified	20. LIMITATION OF ABSTRACT Unlimited	

FOREWORD

Opinions, interpretations, conclusions and recommendations are those of the author and are not necessarily endorsed by the U.S. Army.

 Where copyrighted material is quoted, permission has been obtained to use such material.

 Where material from documents designated for limited distribution is quoted, permission has been obtained to use the material.

 Citations of commercial organizations and trade names in this report do not constitute an official Department of Army endorsement or approval of the products or services of these organizations.

 In conducting research using animals, the investigator(s) adhered to the "Guide for the Care and Use of Laboratory Animals," prepared by the Committee on Care and use of Laboratory Animals of the Institute of Laboratory Resources, National Research Council (NIH Publication No. 86-23, Revised 1985).

 For the protection of human subjects, the investigator(s) adhered to policies of applicable Federal Law 45 CFR 46.

 In conducting research utilizing recombinant DNA technology, the investigator(s) adhered to current guidelines promulgated by the National Institutes of Health.

 In the conduct of research utilizing recombinant DNA, the investigator(s) adhered to the NIH Guidelines for Research Involving Recombinant DNA Molecules.

 In the conduct of research involving hazardous organisms, the investigator(s) adhered to the CDC-NIH Guide for Biosafety in Microbiological and Biomedical Laboratories.

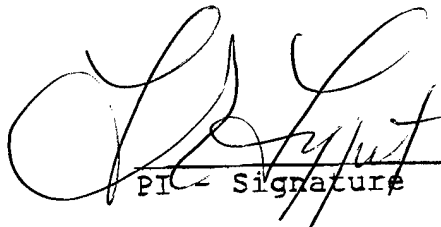
PI Signature

Date

Table of Contents

Front Cover	1
Report Documentation Page (SF 298)	2
Foreword	3
Table of Contents	4
Introduction	5
Methods	7
Results	10
Discussion	17
Conclusion	18
References	19
Appendices	
1. Standard Operating Procedures (Table of Contents)	22
2. Hemoglobin Production Facility - Hemoglobin Production	27
3. Certificate of Analysis - Lot # 951114-00-X	28
4. Certificate of Analysis - Lot # 960123-00-X	29
5. Certificate of Analysis - Lot # 960416-00-X	30
6. Certificate of Analysis - Lot # 960507-00-X	31
7. Certificate of Analysis - Lot # 960709-00-X	32
8. Hemoglobin Inventory (16 September 1996)	33
9. Blood Source Report	34
10. Certificate of Analysis - Lot # 960829-00-C	35
11. Certificate of Analysis - Lot # 960903-00-L	36
12. Manuscript: "An Improved Process for the Production of Sterile Modified Hemoglobin Solutions"	37
13. Stability Study Data 25°C	68
14. Stability Study Data 4°C	69
15. Stability Study Data -80°C	70
16. List of Personnel	71

ANNUAL REPORT: DAMD94-C-4154

INTRODUCTION

Nature of the Problem:

Because combat is synonymous with bloodshed and blood replacement saves lives, the US Army Medical Research and Material Command maintains facilities and programs to develop improved blood products and blood substitutes.

The Background of the Previous Work:

General: The US Army has, for decades, conducted research in red blood cell preservation and the production of acellular hemoglobin solutions for use in combat casualty care. From 1974 through 1992, that research took place at the Letterman Army Institute of Research (LAIR) located at the Presidio. The LAIR facility was closed as the result of Base Realignment and Closure actions and the Blood Research Detachment was relocated to leased laboratory space at 1413 Research Blvd., Rockville, Maryland. On 19 September 1994 The Bionetics Corporation (TBC) was awarded a contract to operate and maintain equipment and provide technical support to the Blood Research Detachment. For the purposes of this report, contract activities will be divided into 3 categories. The first was a Hemoglobin Production Facility (HPF) which consists largely of installed, custom made equipment, most of which was located in a class 10,000 clean room. TBC assembled a team of 4 full-time and 1 part time employees to operate and maintain all equipment associated with those activities. From April into September 1996, the HPF contract staff was supplemented by one part-time active duty technician. Integral to the operation of the HPF was an analytical chemistry laboratory which provides the quality control and characterization testing of the hemoglobin solutions. This

activity will be referred to as Quality Control (QC) within this report and was supported by 1 full-time and 1 part time employee. The third category of activity supported was blood cell preservation research. This activity was encompassed within the Blood Storage Laboratory (BSL), and a fully equipped red cell research laboratory staffed by 3 full-time employees. The Blood Banking Specialist member of this team is also the Project Manager. The entire contract effort was supported by a part-time secretary.

In February 1996, the US Navy assumed funding and programmatic guidance for the HPF only. Navy funding continued until the completion of the contract base period, 20 September 1996, at which time activities related to the HPF and associated QC functions were terminated and the facility closed. Red cell preservation research continued uninterrupted with US Army funding into the first contract option.

HPF: The production of acellular hemoglobin solutions, for which the HPF was designed, is based on biochemical modification of stroma-free hemoglobin as described in the literature.^{1,2,3 and 4} The modified hemoglobin, or the unmodified intermediate, is purified and suspended in a crystalloid solution, dispensed into plastic bags and frozen at -80°C. Alternatively, the hemoglobin solution can be encapsulated in liposomes^{5,6}, thereby more closely mimicking the red blood cell and the physiological state.

BSL: The maximum shelf life of red blood cells stored at refrigerator temperatures using the currently Food and Drug Administration (FDA) licensed anticoagulant, preservative solutions is 42 days after collection. Work by Merriman *et. al.*^{7,8} and Greenwalt, Dumaswala and colleagues^{9,10} indicates potential for extended storage. It is estimated that 1 million units of blood expire per year in the United States and one-third of what is expired and discarded would be used if expiration were extended to 8 weeks¹¹. Extended shelf-life of liquid stored blood would have significant utility to the Armed Services Blood Program as it supports the Department of Defense blood transfusion requirements world-wide.

The Purpose of the Present Work:

HPF: The purpose of the present work is to produce 150 liters per year of a highly purified, well characterized acellular hemoglobin solutions. The material, in turn, is used by the government to support further research to define the mechanisms of toxicity of blood substitutes and complete evaluation for potential Phase I and Phase II clinical trials and eventual commercial development. Second, the Navy's hemoglobin liposome encapsulation process, described above, was duplicated in preparation for scaling to manufacturing in larger quantities. A third purpose is to further refine and optimize the existing hemoglobin production process to understand industrial issues.

QC: The Quality Control laboratory supports the in-process and product release testing needs of the HPF.

BSL: The Blood Storage Laboratory evaluates the effectiveness of novel candidate red blood cell anticoagulant preservative solutions and liquid storage strategies and their potential for further development in conjunction with the physicians and basic scientists in the BRD, WRAIR.

METHODS

HPF: The overall method was to continually evaluate current operations and apply the combined team experience and training to bringing operations into close or full compliance with current Good Manufacturing Practices (cGMP)¹² and identify opportunities for process improvement. Compliance with cGMP's is necessary for Phase I & II developmental therapeutic drugs and devices and is the basis for providing assurance that the system will consistently produce a hemoglobin product meeting the determined specifications and quality desired.

Activities focused on five areas: documentation, equipment repair and maintenance, process improvement, the production of new products and preparation for HPF shut-down.

Documentation: In accordance with cGMP's, the system for tracking, documenting and reviewing all protocols and processes, hereafter referred to as Standard Operating Procedures (SOP's), established in the initial contract period was expanded and refined.

Equipment Repair and Maintenance: The preventive maintenance program of all critical and high value equipment, established during the first contract year, was refined and expanded.

Process Improvement/Optimization: Additional opportunities for process improvement and optimization were identified by comparing the existing manufacturing process to procedures and techniques commonly used by industry. All procedures from cleaning the surfaces and equipment to filling the final container were examined. Six significant process changes were incorporated during this period, three of which incorporated the use of compressed air in place of pumping to move material at three distinct stages in the manufacturing process. Details of the process changes are included in the Results section.

QC: In the Quality Control/Analytical Chemistry Laboratory, assays were modified to fit the needs of the HPF and to conform with GMP's and industry standards of practice¹³ and to adapt to the requirements of the new products being produced, principally the liposome encapsulated hemoglobin (LEH). Modified methods were tested and documented as Standard Operating Procedures. In addition, all assays performed by a reference laboratory were reviewed for possible in-house testing.

The QC laboratory initiated a two-faceted stability study of the cross-linked hemoglobin produced by our facility. The methemoglobin, pH, p50, free iron, endotoxin and percent cross-linking as determined by HPLC were monitored over time on samples stored at room temperature, refrigerator temperature and freezer temperature. The first facet of the study

examined hemoglobin that had been manufactured earlier; the second facet examined freshly prepared cross-linked hemoglobin.

HPF/QC Laboratory Shutdown: In preparation for termination of the HPF portion of the contract, a set of activities related to preparing the HPF for indefinite shutdown was initiated. Discussions were initiated with the COR as soon as it was apparent the HPF operation was not being funded. The COR, along with members of the Hemoglobin Production Committee, guided the process. The shutdown actions focused on consolidation and organization of records, inventory of accountable equipment, partial disassembly of the cross-flow filtration apparatus, installation of a refrigeration monitoring, alarm system, completing SOP documentation, and deactivating the specialized utility systems supporting the HPF.

BSL: The laboratory utilizes an array of pertinent *in vitro* and *in vivo* tests. The *in vitro* assays developed were those classically used in the evaluation of the red cell storage lesion. The laboratory is also capable of performing *in vivo* red cell survival studies. The measure of efficacy specified by the FDA is the 24 hour survival of stored red blood cells. This is measured by recovering ⁵¹Cr labeled stored red blood cells from a circulatory volume precisely determined using ^{99m}Tc labeled, fresh red blood cells. The mean survival of the stored cells must be at least 75% and the hemolysis less than 1.0 % in order to be acceptable for licensure by the Food and Drug Administration (FDA).

Two protocols were initiated during this reporting period; both protocols under terms of a cooperative research and development agreement (CRDA) with the MEDSEP Division of the PALL Filter Corporation. Protocol #572 evaluated an experimental system incorporating a new formulation of chemicals already approved by the FDA for blood storage, AS 24, and integral white blood cell removal filter. The major differences of AS 24 compared to already licensed solution is the presence of 13.0 mM mannitol, elimination of chloride and reduction of tonicity. The white cell removal filter is incorporated to reduce cytokine mediated red blood cell injury¹⁴. The FDA approved AS 3 solution, unfiltered, was the control.

Protocol #591 evaluates a second experimental system which also incorporated a white cell removal filter with the AS 3 solution. In addition the system was reconfigured by relocating the white cell filter for filtration of the whole blood rather than filtration of the packed red blood cells, as was the case in the system used in protocol #572 system. The protocol also evaluates the effect of mixing during the storage period. Unfiltered AS 3 collected cells are also the control for protocol #591. Test units were stored for 8 weeks; control units for 6 weeks.

A separate study to evaluate the effect of short-term (one day) storage of packed red blood cells at room temperature, 25°C, was also initiated. Eight sets of three CPDA-1 units of identical blood group were pooled, mixed and split into three equal aliquots. One aliquot, the control, was stored continuously at 2-6°C for six weeks. The second aliquot, test unit 1, was stored at 2-6°C except for a 24 hour period during the day 7 of storage when it was placed in a 25°C incubator. The third aliquot, test unit 2, was treated the same as test unit 1 except the room temperature exposure occurred at day 21 of storage.

In addition, the BSL also initiated a study to monitor red blood cell deformability and membrane fluidity by ektacytometry. Ektacytometry measures the resistance to a controlled shear force.

RESULTS

General and Administrative: A copy of the Table of Contents for the SOP's which have been written thus far for all contract operations is attached as Appendix 1. Ninety-one SOP's are completed; an additional 22 are in some intermediate stage of preparation. Forty-six SOP's relate to BSL activities and six to general and administrative matters; the remaining 39 relate to HPF operation.

HPF: A total of 106.42 liters of hemoglobin solution containing 11.32 kg hemoglobin was produced which met or exceeded the specifications. Appendix 2 is an account of all hemoglobin manufactured at the WRAIR facility under contract DAMD94-C-4154. The five

lots of cross-linked hemoglobin were all tested for 12 analytes. A summary of results for each analysis is as follows:

SUMMARY OF FINAL PRODUCT TESTING - FISCAL YEAR 1996

<u>Assay</u>	<u>Units</u>	<u>Cross Linked Hb</u>
Total Hemoglobin	g/dl	7.76 - 23.7
Met Hemoglobin	%	2.78 - 5.08
P ₅₀	Torr	25.8 - 31.75
FPLC	%	> 95%
HPLC	%	> 95%
pH	NA	7.05 - 7.45
Osmolarity	mOsm	281 - 295
Free Iron	mol Fe/mol Heme	4.45 - 35.65
Phospholipid	µg/ml	0.03 - 12.8
LAL	Eu/ml	0.125 - 0.5
Sterility	Pass/Fail	PASS
Pyrogen	Pass/Fail	PASS

Abbreviations:

FPLC = fast protein liquid chromatography

HPLC = high performance liquid chromatography

LAL = *limulus* ameocyte lysate

Eu = Endotoxin Units

The Certificates of Analysis for each lot of material produced under contract, data summarized above, are included in this report at Appendices 3 through 7. A copy of the most current inventory has been attached as Appendix 8; this inventory also includes materials other than those produced under contract and also separately identifies hemoglobin manufactured since

10 February 1996 when the Navy began funding the HPF. During the course of the 1996 contract year, 1251 units of expired packed red blood cells were received for the preparation of hemoglobin; 401 units were used to manufacture hemoglobin solution and the remainder were used elsewhere in the Blood Research Detachment or discarded. A copy of the Blood Source Report for both contract years is attached as Appendix 9. In addition to producing cross-linked hemoglobin, two additional products, cyanmethemoglobin and liposome encapsulated hemoglobin (LEH) were manufactured. Certificates of analysis for those products are at Appendices 10 and 11.

A number of process changes have been incorporated into the HPF which have resulted in both time and cost savings from that initially transferred from the LAIR facility. These process improvements have been documented in a manuscript, Appendix 12, jointly authored by contract and government personnel and submitted in September 1996 to the peer-reviewed journal *Biologicals*. A summary of the results is as follows. 1) Purity, as reflected in the fractional yield of the desired $\alpha\alpha\text{Hb}$ product, increased from 60% to 90+% of total hemoglobin recovered and uncross-linked hemoglobin is virtually eliminated. 2) Impurities such as pyrogen, methemoglobin, phospholipid, and free iron were reduced. 3) The net yield of $\alpha\alpha\text{Hb}$ was increased from 33% to 58% of the starting Hb content. 4) Production time, the use of overtime, the consumption of expensive reagents and filters, and losses because of contamination have been reduced. As a result, cost per gram of $\alpha\alpha\text{Hb}$ has decreased by 60%.

A number of process enhancements have been instituted since the previous annual report; these changes are outlined in table format below. Moving material with compressed air at various stages of manufacture rather than by mechanical pumping, increased yield by recovering more of the void volumes in tubing and filters and improved quality by reducing the mechanical shear stress inherent to peristaltic pumping.

**HEMOGLOBIN PRODUCTION PROCESS CHANGES WHICH INCREASED
EFFICIENCY AND OPTIMIZED THE PROCEDURE**

Area of Process Change	Process Change	Overall Change
RBC Pooling	Pool 80 units per lot → Pool to a weight of 20 +/- 1.0 kg	Control and consistency in the beginning step of the process.
RBC Pool Transfer	Peristaltic pump used for transfer → Compressed air used for transfer	Shear stress reduction on material.
Cross Flow Processing Equipment	Removed 0.1 μ hollow fiber filters and eliminated the use of T-13 from the processing	Overall time savings of 4 hours. Water and time savings on cleaning on day two of production. Increase of yield. Cost savings.
Post Cross Linking and Heat Treatment Steps Filtration	Used 1 x 70 μ and 4 x 3 μ filters → Now use 3 x 70 μ and 2 x 3 μ filters	2 hours time savings. 25% cost savings.
Post 70 μ and 3 μ Filtration	Transferred material into a mobile tank containing buffer then transferred through an oxygenator and onto the cross-flow using a peristaltic pump → Transfer material directly through the oxygenator by regulating the flow rates with compressed air	Shear stress reduction on material. Cost savings. Time savings of 2 hours.
Terminal Filtration from T-12	Use of peristaltic pump → Use of compressed air	Shear stress reduction on material.

All attempts to produce hemoglobin A₀ were, disappointingly, unsuccessful. Nearly all of the difficulties encountered were related to preparation of a carboxymethyl (CM) cellulose chromatography column. Resolution of the difficulties was complicated by a manufacturer's defect in the material provided. Each time the column was poured, it compressed excessively and restricted flow rates to unacceptable levels. On other attempts, we were unable to adequately sterilize the column. During the process encountering and resolving each of the difficulties, we learned a great deal about how to prepare the CM cellulose by removing the finer material before pouring the column and selection of agents to sterilize the poured column. In the end, there simply was not enough time to complete a production run.

QC: As a result of reevaluating all assays performed by reference laboratories, the USP specified testing¹³ for purified water used in the HPF and the final product free iron testing were shifted from a reference laboratory to on-site analysis. These changes improved turn-around-time- (TAT), personnel utilization with either a cost savings or no increase in cost. Water testing TAT decreased from approximately five days to two or less; free iron testing TAT decreased from three to five weeks to two or less.

The assumption of LEH production also required modification of the hemoglobin and methemoglobin assays. Eventually an extraction with a combination of solvents was determined which released the hemoglobin for analysis with Drabkin's reagent¹⁵. The conversion for a LAL gel clot to a chromogenic assay was in process at the time of contract termination.

The hemoglobin stability study on a freshly prepared lot of hemoglobin, lot 960123-00-X, was completed through six months. The termination of the contract prevented examination further testing. Results from testing at 25°C, 4°C and -80°C are contained in Appendices 13, 14 and 15 respectively. As expected, the hemoglobin solution showed no significant changes at 6 months if stored at -80°C, but deteriorated at warmer temperatures. Methemoglobin formation, release of

free iron and a left shifted p50 was most dramatic at room temperature, 25°C. Other parameters were unaffected.

HPF/QC Laboratory Shutdown: The third set of activities was focused on preparing the HPF for indefinite shutdown. Discussions were initiated with the COR as soon as it was apparent the HPF operation was not being funded. The COR, along with members of the Hemoglobin Production Committee, guided the process. The following actions were taken.

- ▶ All manufacturing and quality control records, including those from LAIR, were consolidated and organized. This will facilitate retrieval of data on material either in storage or for material which is in the hands of investigators. The existence of complete and well organized records is especially critical in the event it is necessary to identify an affected lot because of an HIV look back.
- ▶ On 17 September, all accountable equipment was inventoried and results of the inventory given to the COR.
- ▶ The cross-flow filtration apparatus was partially disassembled. The reasons for disassembling were to completely drain any liquid from the system which could be a site for bacterial or fungal growth, and to open seals which would fuse over time making disassembly and reassembly problematic. Photographs were taken prior to disassembly and the loose parts were labeled and placed in the walk-in refrigerator.
- ▶ All keys were assembled, labeled, and placed in a key box which was given to the COR.
- ▶ All chemicals were removed from the plant and relocated to the chemical storage room.
- ▶ A monitoring system was purchased to notify the government staff of any refrigeration failure in any of the six freezers containing hemoglobin inventory.
- ▶ All draft SOP's for the HPF and QC laboratory were either finalized or retyped and consolidated with the file copies of all the completed SOP's. These SOP's will be a valuable resource for any staff which attempts to restart the HPF.
- ▶ The high volume water purification apparatus was drained and resin beds, provided by the vendor who maintained the unit, were removed. The reason for draining the system was to

remove any stagnant water which would be a place for potential contamination. Once contaminated, restarting the unit would become a much more difficult task.

- ▶ The chiller, steam generator, air compressor and air drying unit were shut down according to manufacturers' directions.
- ▶ The clean room micro-filtration system received a preventive maintenance check by the firm which had been providing maintenance and certification during the past two years.

BSL: Preliminary results for the studies either completed this year or still in progress at the conclusion of the FY are as follows:

Protocol # 572: Eleven volunteers completed the study. Double-labeled 24 hour post-transfusion survival for the filtered AS 24 test units averaged 64% with a range of 52-83 %. AS 3 control unit 24 hour post-transfusion survival averaged 77.2% and ranged from 70- 95% among the 11 reinfusions evaluated. Mean hemolysis for the test units was 0.312% (0.158-0.680%) and 0.493% (0.171-1.062%) for the controls.

Protocol # 591: Thirteen volunteers completed the first phase of the study which evaluated unmixed storage. Double-labeled 24 hour post-transfusion survival for the filtered AS 3 test units stored for eight weeks averaged 76.6% with a range of 60-75 %. AS 3 control unit 24 hour post-transfusion survival averaged 77.2% and ranged from 69-84% after six weeks of storage. Mean hemolysis for the test units was 0.207% (0.082-0.399%) and 0.493% (0.23-1.795%) for the controls.

Short-term room temperature storage protocol: Control units has higher ATP and glucose levels, less hemolysis and equivalent red cell morphology scores than test units. Warmed units (test units) had adequate ATP and glucose, equivalent hemolysis and better morphology scores at day 28 than control units at day 35. Red cell morphology scores improved dramatically immediately after warming of test units at day 21, but dropped sharply in the post warming period.

Ekatcytometry: Insufficient data has been collected.

DISCUSSION

HPF: The HPF was fully operational with a trained and experienced staff until 20 September 1996, the day funding for HPF activity was terminated. The hemoglobin solution produced met or exceeded specifications for quality and purity. The cumulative volume of hemoglobin produced is skewed by the deliberate production of a highly concentrated lot, #960709. The concentration was increased to enhance the amount of hemoglobin protein incorporated during liposome encapsulation. The hemoglobin concentration of this lot, 23.7 gm/dl, was nearly 2.5 times the usual concentration of 8 to 10 gm/dl and was achieved without significant degradation in quality.

The versatility, adaptability and capability of the staff, facility and process were dramatically demonstrated in the production of the new products, LEH and cyanmethemoglobin. There is no reason to believe the difficulties encountered in producing hemoglobin A₀ would not also have been overcome with a reasonable amount of time.

Processes improvements instituted, both in the first and second years of operation, significantly improved quality and yield of the final product and reduced labor required to produce a lot of hemoglobin solution when compared with operations when the HPF was at LAIR.

QC: The Quality Control laboratory continued to support the evolving needs of the HPF for support of in-process operation of the HPF and final product characterization. Methods were developed and/or adapted to testing new products, most notably the LEH. The effectiveness and efficiency of the operation was improved by the shifting of some assays from testing at a reference laboratory to on-site testing.

The hemoglobin produced by the HPF appears to be unaffected by -80°C storage for 6 months and probably longer. However, oxidation, as monitored by methemoglobin formation exceeds 10% within 2 weeks at room temperature and within 2 months when stored at 4°C. This confirms earlier published research which examined different formulations of biochemically modified and A₀ hemoglobin¹⁶.

BSL: The two candidate red cell collection and storage systems evaluated to date do not appear to provide the minimum 75% 24-hour post-transfusion survival required by the FDA licensure. Hemolysis is well within the maximal allowed.

The red cell warming study yielded an intriguing finding of dramatically improved morphological scores immediately after warming late in the storage period. Whether this observation represents an improvement in red cell viability mediated by rejuvenation of membrane metabolic processes or merely a testing artifact will require further investigation. The equivalent results of warmed units at day 28 when compared to control units at day 35 confirms unpublished results using CPD collected red cells¹⁷ which suggested a day at room temperature accelerated the storage lesion by a week, i.e., if the red cells are stored at room temperature for a day, the useful shelf-life of the unit is reduced one week.

Taken together, the ambiguity of the results for the two red cell survival studies and the warming study indicate a need to explore more basic questions related to red cell senescence and the lesion of refrigerated storage.

CONCLUSION:

The contract staff has supported the BRD by operating and maintaining the HPF and producing well characterized, high quality hemoglobin solutions in quantities which met the contract requirements. Staff were fully trained and the necessary quality control and documentation systems were in place to support both existing and new requirements. Substantial additional progress was made toward process improvement and cGMP compliance. The BSL staff has likewise established the required assays and procedures to support blood preservation research. Staff are trained and systems are in place which supported specific red cell survival protocols. The BRD mission has been supported.

REFERENCES

1. Chapman KW, Snell SM, Jesse RG, Morano JK, Everse J, and Winslow RM. Pilot Scale Production of Pyrogen-Free Human Hemoglobin for Research, *Biomat., Art. Cells & Immob. Biotech.* 1992; 20(2-4):415-421.
2. Nelson D, et.al. Preparation and Characterization of Diaspirin Cross-Linked Hemoglobin Solutions for Preclinical Studies, *Biomat., Art. Cells & Immob. Biotech.* 1992; 20(2-4):423-427.
3. Winslow RM and Chapman KW. Pilot-Scale Preparation of Hemoglobin Solutions, *Methods in Enzymology.* 1994; 231:3-16.
4. Farmer M, Ebeling A, Marshall T, Hauck W, Sun CS, White E, Long Z. Validation of Virus Inactivation by Heat Treatment in the Manufacture of Diaspirin Cross linked Hemoglobin, *Biomat., Art. Cells & Immob. Biotech.* 1992; 20(2-4):429-433.
5. Cliff RO, Ligler F, Goins B, Hoffmann PM, Speilberg H, Rudolph AS. Liposome Encapsulated Hemoglobin: Long-Term Storage Stability and In Vivo Characterization, *Biomat., Art. Cells & Immob. Biotech.* 1992; 20(2-4):619-626.
6. Rudolph AS.) Encapsulation of Hemoglobin in Liposomes, *Blood Substitutes: Physiological Basis of Efficacy*, 1995; 7:90-104.
7. Merryman HT, Hornblower M, Syring RL. Prolonged Storage of Red Cells at 4°C. *Transfusion.* 1986; 26:500-505.
8. Merryman HT, Hornblower M, Syring RL, Mesbah-Karimi N. Extending the Storage of Red Cells at 4°C. *Transfusion Science.* 1994; 15:105-115.

9. Greenwalt TJ, McGuinness CG, Dumaswala UJ, Carter HW. Studies in Red Blood Cell Preservation 3. A Phosphate-Ammonium-Adenine Additive Solution. *Vox Sanguinis*. 1990; 58:94-99.

10. Dumaswala UJ, Oreskovic RT, Petrosky TL, Greenwalt TJ. Studies in Red Cell Preservation 5. Determining the Limiting Concentrations of NH_4Cl and Na_2PO_4 Needed to Maintain Red Blood Cell ATP During Storage. *Vox Sanguinis*. 1992; 62:136-140.

11. Surgeoner D, Klein H, Institute of Medicine Conference on Blood Safety and Availability, 9 June 1995, Washington, DC.

12. Code of Federal Regulations, Office of the Federal Register National Archives and Record Administration, 21CFR pt.210, 211, 600, and 312.160(subpart G).

13. The United States Pharmacopeia, (1994) USP 23(NF18), Rand McNally, Taunton,MA. <1035> pp.1847-1848, <1041> pp.1849, <1077> pp.1907-1917, <1206> pp.1963-1975, and <1211> pp.1976-1981

14. Matthes G. Metabolic Findings Resulting from In-line Filtration of Red Blood Cells. *Transfusion Today*. 1994; 21:8-10.

15. International Committee for Standardization in Hematology: Recommendation for Reference Method for Hemoglobinometry in Human Blood. (ICSH Standard EP6/2:1977) and Specifications

for International Hemoglobin Cyanide Reference Standard Preparation (ICSH Standard EP 6/3:1977). J. Clin. Path. 1978; 31:139.

16. Moore GL, Zegna A, Ledford ME, Huling JP, Fishman RM. Evaluation of Methemoglobin Formation During the Storage of Various Hemoglobin Solutions, *Artif. Organs*, 1992; 16:5, 513-8.

17. Moore GL. Unpublished, 1995.

THE BIONETICS CORPORATION
STANDARD OPERATING PROCEDURE
TABLE OF CONTENTS

DEPARTMENT
100 - QUALITY ASSURANCE, DOCUMENTATION
GENERAL POLICIES

SOP NUMBER	PROCEDURE TITLE	DATE ISSUED REVISION DATE
B411-101	Preparation of Standard Operating Procedure for Bionetics Contract 411	* 08/22/95R
B411-102	Purchasing and Invoicing Procedures	* 07/12/95
B411-103	Documentation Policies for Bionetics Contract 411	* 07/21/95
B411-104	Identification System for Standard Operating Procedures	* 07/31/95
B411-105	Procedure for Handling In-Process Samples and Results	12/01/95
B411-106	cGMP and Safety Training Program for Bionetics Contract B411 Personnel	12/01/95
B411-107	Deviation Reporting for Contract C411	03/04/96
B411-108	Nonconforming Material	DRAFT
B411-109	Blood Storage Laboratory & Donor Room Training Policy	10/01/96

200 - ASSAYS
SOP NUMBER **PROCEDURE TITLE**

SOP NUMBER	PROCEDURE TITLE	DATE ISSUED REVISION DATE
B411-201	Quality Control Assay Reporting	

DEPARTMENT
200 - ASSAYS Continued

SOP NUMBER	PROCEDURE TITLE	DATE ISSUED REVISION DATE
B411-202	Endotoxin Test Via Limulus Amoebocyte Lysate Assay	03/04/96
B411-203	Osmolality Determination using AI Digimatic	*09/29/95
B411-204	Determination of p50 using Hemox Analyzer	05/23/96
B411-205	CANCELED	
B411-206	Determination of Phospholipids in Hb Solution	
B411-207	Determination of Methemoglobin in Hb Solutions	01/04/96
B411-208	Deproteinization Procedure for Making Protein-Free Extracts	08/02/96R
B411-209	Determination of 2,3 Diphosphoglyceric Acid in Protein-Free Extracts of Red Blood Cells	12/01/95
B411-210	Determination of Adenosine 5' Triphosphate in Blood using Diff. Spectrophotometry	04/22/96
B411-211	Determination of Lactate (L Lactic Acid) in Protein Free extracts of Red Blood Cells	04/22/96
B411-212	Determination of Human Erythrocyte Morphology Index	09/26/96R
B411-213	ABO/RH Typing of Donors, Tube Technique	07/18/96R

THE BIONETICS CORPORATION
STANDARD OPERATING PROCEDURE
TABLE OF CONTENTS Continued

<u>DEPARTMENT</u> 200 - ASSAYS Continued		<u>DEPARTMENT</u> 200 - ASSAYS Continued			
SOP NUMBER	PROCEDURE TITLE	DATE ISSUED REVISION DATE	SOP NUMBER	PROCEDURE TITLE	DATE ISSUED REVISION DATE
B411-214	Manual Red Blood Cell Osmotic Fragility Determination	10/06/95	B411-226	HPLC Analysis of Cross-Linked Hb	
B411-215	Manual Leukocyte Count Using the Nageotte Counting Chamber	07/18/96R	B411-227	Biological Indicator Incubation	01/04/96
B411-216	Micro-Mematocrit Determination	07/18/96R	B411-228	Residual Phosphate Assay	01/19/96
B411-217	Sickle Cell Testing of Research Donors	07/18/96R	B411-229	Conductivity Determination	
B411-218	Plasma/Supernatant Hemoglobin- Micro Drabkins Method	01/17/96	B411-230	Raw Materials testing of Chemicals used in the Hb Production Facility	05/20/96
B411-219	Serum hCG(Pregnancy) Testing of Protocol Participants with Clearview HCG Duo Testing Kit	09/27/96R	B411-231	Determination of Glucose Using the Roche COBAS Fara	01/17/96
B411-220	Total Hemoglobin Concentration Determination	12/06/95	B411-232	Determination of Electrolytes Using the Roche COBAS Fara	01/17/96
B411-221	Microbiological Evaluation for Hemoglobin Product	12/01/95	B411-233	Quantitation of Free Iorn in Hb Solutions	07/02/96
B411-222	Environmental Monitoring During Aseptic Processes	01/19/96	B411-234	Propidium Iodide Staining for Quantification of Low Numbers of White Cells Concentration Method	05/01/96
B411-223	Personnel Monitoring During Aseptic Processes	01/19/96	B411-235	Particle Counting Using the Climet CI-1000 Particle Analyzer	DRAFT 08/26/96
B411-224	Reverse Phase High Performance Liquid Chromatography of Hb Solutions	01/04/96	B411-236	Determination of Lactate using the Roche Cobas Fara	07/05/96
B411-225	USP Water Testing for the Continental Purified Water System	01/04/96	B411-237	Sterility Check of Stored Blood	07/03/96

THE BIONETICS CORPORATION
STANDARD OPERATING PROCEDURE
TABLE OF CONTENTS Continued

DEPARTMENT 300 - EQUIPMENT		DEPARTMENT 300 - EQUIPMENT Continued	
SOP NUMBER	PROCEDURE TITLE	SOP NUMBER	PROCEDURE TITLE
DATE ISSUED REVISION DATE	DATE ISSUED REVISION DATE	DATE ISSUED REVISION DATE	DATE ISSUED REVISION DATE
B411-301	Refrigerator/ Freezer Temperature Monitoring	B411-314	Use of Damon Clinical Centrifuge
B411-302	Solution 2000 Water System	B411-315	Use and Maintenance of the Fisher YSI Conducting
B411-303	pH Determination Using The Beckman 70 Meter	B411-316	Use of the Beckman DU-62 Spectrophotometer
B411-304	Solution 2000 Water System Sanitization	B411-317	Calibration of Instrumentation in Analytical Chemistry Laboratory
B411-305	Maintenance of the Baker System 9000	B411-318	Operation and Maintenance of Manual Micropipetters
B411-306	Maintenance of the Roche COBAS Fara w/ ISE Moduleq	B411-320	Proper Use and Maintenance of the Baker Biological Safety Cabinet
B411-307	Operation of the Baker System 9000	B411-321	pH Determination Using the Sentron Model 1001 pH System
B411-308	Operation of the COBAS Fara II with ISE Module	B411-322	Use and Maintenance of Perkin Elmer λ 4 Aspectsphotometer
B411-309	Maintenance of the Corning 855	B411-323	Operation and Maintenance of the Yamato Mechanical Convention Oven
B411-310	Operation of the Corning 855	B411-324	pH Determination Using the ATO Orion Model 420A pH Meter
B411-311	Use of the LKB-WALLACE CimiGamma Counter	B411-325	Operation and Maintenance of the Cole Parmer Thermocouple Thermometer
B411-312	Maintenance of Advanced Instrument Diatmatic Osmometer Model 3D II	B411-326	Proper Use and Maintenance of the Biological Safety Cabinets for Blood Storage Laboratory
B411-313	Use of the Capintec CRC - 50 Dose Calibrator		

THE BIONETICS CORPORATION
STANDARD OPERATING PROCEDURE
TABLE OF CONTENTS Continued

DEPARTMENT
400- MANUFACTURING/FILLING-H P F

DEPARTMENT
400 - MANUFACTURE/FILLING -H P F Continued

SOP NUMBER	PROCEDURE TITLE	DATE ISSUED REVISION DATE	SOP NUMBER	PROCEDURE TITLE	DATE ISSUED REVISION DATE
B411-401	Inventory/Distribution /Packing /Shipping of Hemoglobin	* 05/05/95	B411-415	Preparation of the Lysis Buffer	05/03/96
B411-402MR	Hemoglobin Fill Master Record	DRAFT 08/13/96	B411-416	Preparation of the Final Buffer	DRAFT 08/13/96
B411-403	Cleaning & Sanitization Buffer Tanks and Mixing Tank	* 09/20/95	B411-417	Gowning Procedure for the HPF	DRAFT 08/13/96
B411-404MR	Stroma Free Hemoglobin Master Record	DRAFT 08/23/96	B411-418	Preparation of Tubing and Fittings used in the Hemoglobin Manufacturing Processes	DRAFT 09/06/96
B411-405MR	Master Record Bioreactor	DRAFT 08/23/96	B411-419	Hemoglobin Sampling Procedures in the HPF	DRAFT 08/13/96
B411-406MR	Master Record Reoxygenation	DRAFT 08/05/96	B411-420	Cleaning & Assembly of the Filter Housing	DRAFT 08/13/96
B411-407	Steam Sterilization of Buffer Tanks	* 09/29/95	B411-421	Assembly and Installation of Satorious and Pall Minifilters	DRAFT 08/13/96
B411-408	Assignment of Lot Numbers for the Hemoglobin Production Facility	* 07/07/95			
B411-409	Sanitization of the Walls in the HPF	12/14/95	500 - DONOR	PROCEDURE TITLE	DATE ISSUED REVISION DATE
B411-410	Sanitization of Exterior Surfaces in the HPF	12/14/95	B411-501	Preparation of Packed Red Blood Cells	02/28/95
B411-411	Sanitization of the Floors in the HPF	01/19/96	B411-502	Preparation of Leukodepleted Packed Red Blood Cells	05/03/96R
B411-412	Cleaning of Floors in the HPF	01/19/96	B411-503	Record of Donor Participation in Blood Storage Research	03/08/95R
B411-413	Reverse Osmosis Purified Water Sampling	01/19/96			
B411-414	Preparation of the Wash and Diafiltration Buffers	04/01/96R			

THE BIONETICS CORPORATION
STANDARD OPERATING PROCEDURE
TABLE OF CONTENTS Continued

<u>DEPARTMENT</u> 500 - DONOR Continued		<u>DEPARTMENT</u> 600- RAW MATERIAL SPECIFICATIONS Continued	
SOP NUMBER	PROCEDURE TITLE	DATE ISSUED REVISION DATE	SOP NUMBER PROCEDURE TITLE DATE ISSUED REVISION DATE
B411-504	Autologous Blood Donation Process for <i>in vivo</i> Research	03/08/95R	B411-606 Specifications for Buffers Used in the Hemoglobin Production Facility 01/03/96
B411-505	Recruitment of Research Donors	09/26/96R	B411-607 Receipt and Distribution of Inventory Used in the HPF DRAFT 08/06/96
B411-506	Payment of Blood Donor		B411-608 HPF Supply and Vendor List DRAFT 08/06/96
B411-507	Action Plan for Medical Complications in Research Volunteers	09/22/95R	
B411-508	Donor Phlebotomy		
<u>600- RAW MATERIAL SPECIFICATIONS</u>		<u>700- RADIOSAFETY</u>	
SOP NUMBER	PROCEDURE TITLE	DATE ISSUED REVISION DATE	SOP NUMBER PROCEDURE TITLE DATE ISSUED REVISION DATE
B411-601	Receipt of Red Blood Cell Units for the Manufacturing of Hemoglobin	05/20/96R	B411-704 Purchase and Receipt of Radioactive Material 01/17/96R
B411-602	Red Blood Cell Specifications	04/03/96R	B411-705 Safe Use and Monitoring of Radioactive Material * 06/02/95
B411-603	Destruction of Red Blood Cell Units	02/07/96R	B411-706 Spills of Radioactive Material *08/21/95R
B411-604	Final Release of Hemoglobin Products	12/01/95	B411-707 Radioactive Waste Disposal * 06/02/95
B411-605	Raw Material Specification-Approved Disinfectants for Use in the HPF	12/01/95	B411-708 Storage of Radioactive Material * 06/02/95
			B411-709 Training for Users of Radioactive Material * 06/02/95
			800 - VALIDATION
			900 -
			2SOP. TBL [Administrative Disk]
			Revision Date 10/18/96

**HEMOGLOBIN PRODUCTION FACILITY
HEMOGLOBIN PRODUCTION
FISCAL YEAR 1996**

Lot #	Final Concentration (gm/dl)	Yield (kg)	Total Hemoglobin (gm)
951114	9.21	15.44	1422
960123	7.85	30.22	2372
960416	9.57	23.2	2220
960507	11.14	29.1	3242
960709	23.7	8.1	2068
Totals		106.04	11320

CERTIFICATE OF ANALYSIS
FINAL CONTAINER
CROSS LINKED HEMOGLOBINLOT #: 951114-00-X

<u>ASSAY</u>	<u>RESULT</u>
Total Hemoglobin	9.21 g/dl
Met Hemoglobin	4.00 %
P ₅₀	25.8 Torr
FPLC	>95%
HPLC	>95 %
pH	7.24
Osmolarity	287 mOsm
Free Iron	35.65 µg/ml
Phospholipids	12.8 µg/ml
LAL	0.25 EU/ml
Sterility	PASS
Pyrogen	PASS

Project Manager: *J. E. Hyatt Ph.D. SDB(ASCP)*Date: 5 February 1996

CERTIFICATE OF ANALYSIS
FINAL CONTAINER
CROSS LINKED HEMOGLOBIN

LOT #: 960123-00-X

<u>ASSAY</u>	<u>RESULT</u>
Total Hemoglobin	7.85 g/dl
Met Hemoglobin	3.53 %
P ₅₀	26.0 Torr
FPLC	>95 %
HPLC	>95 %
pH	7.21
Osmolarity	288 mOsm
Free Iron	4.45 µg/ml
Phospholipids	1.25 µg/ml
LAL	0.25 EU/ml
Sterility	PASS
Pyrogen	PASS

Project Manager:

Date:

[Handwritten Signature]
SB3 (ASCP)

5 June 1996

CERTIFICATE OF ANALYSIS
FINAL CONTAINER
CROSS LINKED HEMOGLOBINLOT #: 960416-00-X

<u>ASSAY</u>	<u>RESULT</u>
Total Hemoglobin	7.76 g/dl
Met Hemoglobin	3.80 %
P ₅₀	31.75 Torr
FPLC	>95 %
HPLC	>95 %
pH	7.05
Osmolarity	281 mOsm
Free Iron	4.71 µg/ml
Phospholipids	0.3 µg/ml
LAL	0.125 EU/ml
Sterility	PASS
Pyrogen	PASS

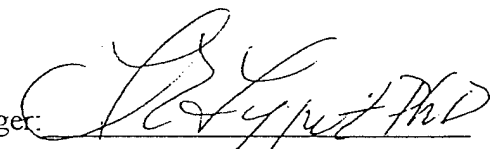
Project Manager: Date: 6 June 1996

CERTIFICATE OF ANALYSIS
FINAL CONTAINER
CROSS LINKED HEMOGLOBIN

LOT #: 960507-00-X

<u>ASSAY</u>	<u>RESULT</u>
Total Hemoglobin	7.86 g/dl
Met Hemoglobin	2.78 %
P ₅₀	29.5 Torr
FPLC	>95 %
HPLC	>95 %
pH	7.45
Osmolarity	282 mOsm
Free Iron	5.78 µg/ml
Phospholipids	0.9 µg/ml
LAL	0.5 EU/ml
Sterility	PASS
Pyrogen	PASS

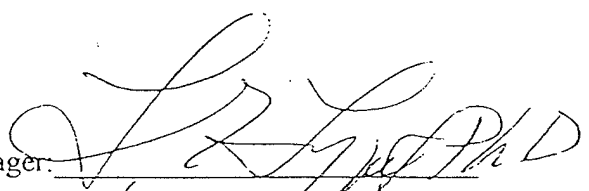
Project Manager: 

Date: 30 July 1996

CERTIFICATE OF ANALYSIS
FINAL CONTAINER
CROSS LINKED HEMOGLOBIN

LOT #: 960709-01-X

<u>ASSAY</u>	<u>RESULT</u>				
Total Hemoglobin	23.70 g/dl				
Met Hemoglobin	5.08 %				
P ₅₀	29.5 Torr				
FPLC	>95 %				
HPLC	>95 %				
pH	7.31				
Osmolarity	297 mOsm				
Free Iron	14.92 µg/ml				
Phospholipids	0.54 µg/ml				
LAL	0.25 EU/ml				
Sterility	PASS				
Pyrogen	PASS				
Particles (Informational Purposes Only)	<table> <tbody> <tr> <td>≥10µm particles</td> <td>91 particles/ml</td> </tr> <tr> <td>≥25µm particles</td> <td>3 particles/ml</td> </tr> </tbody> </table>	≥10µm particles	91 particles/ml	≥25µm particles	3 particles/ml
≥10µm particles	91 particles/ml				
≥25µm particles	3 particles/ml				

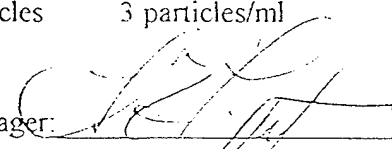
Project Manager: 

Date: 15 August 1996

HEMOGLOBIN INVENTORY

TYPE	LOT #	VOLUME (liters)	FORMULATION
Ao			
Hemosol	US94HP01	5.65	HemAzero
Stroma Free			
→	950111-00-S	9.12	Phosphate
→ NRL	950808-00-S	9.53	Saline
Cross Linked			
	92134	300 ml (1 x 300ml)	Phosphate
	92141	2.5	CnMet
→	950207-00-X	9.0	RA
→	950314-00-X	10.5	RA
→	950404-00-X	6.12	RA
→	951114-00-X	14.3	RA
→	960123-00-X	26.21	RA
→ ✓	960416-00-X	21.334	RA
→ ✓	960507-00-X	27.65	RA
→ ✓	960829-00-C	3.98	CnMet

→ Inventory manufactured under contract DAMD17-94-C-4154.

✓ Inventory manufactured under Navy MRDC.

16 September 96

BLOOD SOURCE REPORT

PERIOD: SOURCE	FISCAL YEAR 1995					FISCAL YEAR 1996				
	QTR 1	QTR 2	QTR 3	QTR 4	CUM	QTR 1	QTR 2	QTR 3	QTR 4	CUM
WRAMC	62	54	46	46	162			103		103
FAMC	91	151	161	161	403	72	112			184
MAMC	22	19	18	18	59	30	65		17	82
CAMP MEMORIAL / KNOX	60		48	48	108					0
BLOOD BANK CENTER / HOOD	30				30		101	86	35	222
NOBLE ACH	21	78	17	17	116	13	12			25
ASWBPL / MCQUIRE	130	61	18	15	224					0
NATIONAL NAVAL MEDICAL CENTER		113	37	62	212	27	448	78	52	605
PORTSMOUTH NAVAL MED CEN				10						0
WILFORD HALL AIR FORCE MED CEN				11						0
NIH CLINICAL CENTER				31						0
TOTAL	190	400	357	419	1366	142	738	267	104	1251

7 OCT 96 / LEL
BLDSOURC.XLS/S1

**CERTIFICATE OF ANALYSIS
FINAL CONTAINER
CYANMET HEMOGLOBIN**

LOT #: 960829-00-C

<u>ASSAY</u>	<u>RESULT</u>
Total Hemoglobin	9.24 g/dl
Met Hemoglobin	2.08 %
CyanMet Hemoglobin	97.8 %
Free Iron	1.1 µg/ml
Osmolality	67 mOsm
LAL	<0.06 Eu/ml
Sterility	Not Done

**CERTIFICATE OF ANALYSIS
FINAL CONTAINER
LIPOSOME ENCAPSULATED HEMOGLOBIN**

LOT #: 960903-00-L

<u>ASSAY</u>	<u>RESULT</u>
Total Hemoglobin	9.66g/dl
Met Hemoglobin	32.98 %
Hematocrit	14.75 %
p50	29.75 Torr
Phospholipid	2.49 mg/ml
Sterility	Not Done

An Improved Process for the Production of Sterile Modified Hemoglobin Solutions

Frank A. Highsmith,¹ Christine M. Driscoll,¹ Brian C. Chung,¹ Mark D. Chavez,² Victor W. Macdonald,² James M. Manning,³ Lloyd E. Lippert,¹ Robert L. Berger,² John R. Hess^{*2}

¹The Bionetics Corporation, Rockville, MD, ²The Blood Research Detachment of the Walter Reed Army Institute of Research, Washington, DC, and ³The Rockefeller University, New York, NY.

The opinions expressed herein are the private views of the authors, and are not to be construed as official or as reflecting the views of the U.S. Department of the Army or of the U.S. Department of Defense.

*To whom correspondence should be addressed: Col. John R. Hess, M.D., Walter Reed Army Institute of Research, Blood Research Detachment, Washington DC 20307-5100.

Abstract

The process for manufacturing bulk quantities of sterile solutions of human hemoglobin (Hb) cross-linked between the alpha chains ($\alpha\alpha$ Hb) with bis-(3,5-dibromosalicyl) fumarate (DBBF) was modified to: 1) improve product purity 2) increase product yield 3) eliminate non-U.S.P. materials 4) reduce reagent costs and 5) reduce production time. These process modifications were the results of increased scientific understanding of the Hb cross-linking chemistry and were in the form of engineering and procedure controls that reflect current good manufacturing practices (cGMP). Purity, as reflected in the fractional yield of the desired $\alpha\alpha$ Hb product, has increased from 60% to 90+% of total Hb, and uncross-linked Hb was virtually eliminated. Impurities such as pyrogens, methemoglobin, phospholipid, and free iron were reduced. The net yield of $\alpha\alpha$ Hb was increased from 33% to 58% of starting Hb content. Production time, the use of overtime, the consumption of expensive reagents and filters, and losses because of contamination have all been reduced. As a result, cost per gram of $\alpha\alpha$ Hb produced has decreased 60%. With this improved process, efficient production of very pure $\alpha\alpha$ Hb is possible.

Key words: blood substitutes, blood products, bis(3,5-dibromosalicyl)fumarate, cross-linked hemoglobin, protein purification, good manufacturing practice

I. Introduction

The U.S. Army produces kilogram quantities of modified hemoglobin from outdated human red blood cells to support research in the development of red blood cell substitutes. The Army seeks a blood substitute to serve as a universal oxygen-carrying resuscitation fluid on the battlefield. Hemoglobin, with its high oxygen carrying capacity, moderate colloid osmotic activity, and low antigenicity, is the most likely candidate blood substitute material.¹ Volumes greater than 100 liters per year of sterile 10 g/dl hemoglobin solutions are required to support this ongoing research and development process. The total volume is large because the safety and efficacy testing of resuscitation fluids require the infusion of substantial volumes of the material. Further, the manufacture of a major derivative product, a liposome encapsulated hemoglobin, is only 15% efficient and requires large volumes of starting material.² Additional volumes of the hemoglobin are used for research into several types of brain injury and for basic studies of hemoglobin function and modification.^{3,4}

The Army's original hemoglobin production facility was built at the Letterman Army Institute of Research (LAIR) on the Presidio of San Francisco in 1990. Descriptions of the original process and product have been published.⁵ In 1993, with the closure of the Letterman Institute, the facility was moved to the Walter Reed Army Institute of Research (WRAIR) and reestablished. The facility was rebuilt by a civilian engineering firm, brought to operation by Army personnel, and then turned over to an industrial operating company for continued operation and maintenance.

To understand the rationale for the process of hemoglobin recovery, modification, and purification, a brief discussion of the biochemistry and physiology of hemoglobin is necessary.

Hemoglobin is the primary oxygen carrier in all higher animals. Normally, it is present in red blood cells, which provide the environment necessary for its proper function and protect the hemoglobin from degradation. Hemoglobin is a classic allosteric protein in that a ligand or effector molecule binding at one site on the hemoglobin can change the binding of ligands at other sites.⁶ When the hemoglobin molecule binds oxygen, it changes conformation. Low affinity deoxyhemoglobin, with four potential oxygen binding sites, turns into higher affinity partially liganded oxyhemoglobin. In this way, oxygen affinity increases with each subsequent oxygen molecule bound, an effect called cooperativity. This cooperativity is delicately balanced to allow blood to saturate with oxygen in the lung and yet unload the oxygen as oxygen partial pressures decline in the tissues. Cooperativity is usually visualized as the sigmoid curve that relates oxygen partial pressure to the fractional saturation of hemoglobin. It is often expressed as a logarithmic function of the slope of the curve (the Hill number) at the point where the hemoglobin is 50% saturated (the P_{50}).⁷

In the red blood cell, hemoglobin oxygen affinity is regulated by H^+ , CO_2 , Cl^- , and 2,3-diphosphoglycerate (2,3-DPG). 2,3-DPG is the most important of these effectors in normal cells, stabilizing the deoxy- form and reducing the oxygen affinity. When hemoglobin is removed from red blood cells, most of the 2,3-DPG and CO_2 disperse. Without these effectors, the oxygen affinity rises as seen in the decrease in the P_{50} from 27 Torr to 10 Torr. Cooling further reduces the affinity of hemoglobin stripped of effectors from a P_{50} of 10 Torr at $37^\circ C$ to 4 Torr at $5^\circ C$.⁸ The unloading of oxygen then becomes difficult because of the small partial pressure gradient available to drive it away.

Structurally, native hemoglobin is a tetramer composed of two alpha globin and two beta

globin chains ($\alpha\alpha\beta\beta$). Each individual globin protein chain is folded to surround an iron-containing heme group where oxygen is bound and released. The folding of the monomers and their assembly into a tetramer are all controlled by noncovalent interactions. These interactions are weakest between the like globin chains, so hemoglobin tetramer is in rapid equilibrium with the low concentrations of heterodimer $[\alpha\alpha\beta\beta \rightleftharpoons 2(\alpha\beta)]^{9,10}$ (Figure 1a). Within the red blood cell, heterodimers are retained and rapidly reassociate back to tetramer. Outside the red blood cell, the free heterodimer is not desirable because it is filtered and accumulated by the kidney causing renal damage. Even the unmodified tetramer is also not desirable in the circulation because it dissociates into heterodimers and because unmodified tetramer binds oxygen more avidly and less cooperatively than normal blood.

In manufacturing a hemoglobin-based blood substitute, the problems of tetramer-dimer equilibrium and high oxygen affinity are addressed by modifying the hemoglobin tetramer. The hemoglobin modification used in this process, cross-linking the α -globin chains from one α -lysine-99 to the other with fumarate,¹¹ prevents the formation of the dimer and subsequent renal damage (Figure 1b). In addition, cross-linking between the α -lysine-99s makes the binding and release of oxygen by the cross-linked tetramer ($\alpha\alpha\text{Hb}$) much like that of normal blood.

Another concern of manufacturing is maintaining the integrity of the product. Despite the relative stability of hemoglobin, heat, shear, and oxidative stress can all damage the molecule. Oxidation of Fe^{2+} hemoglobin to Fe^{3+} methemoglobin is the usual first step in the degradation of oxygenated solutions at room or body temperatures. Inside the red blood cell hemoglobin oxidation is quickly reversed by the methemoglobin reductase enzyme system. Outside the red blood cell the conversion to methemoglobin proceeds unchecked. The molecule can further

degrade with the loss of heme and iron and the unraveling of the protein to form linear strands that aggregate and precipitate. The hemoglobin breakdown products, heme and iron, can potentiate oxygen free radical reactions and lead to further protein damage.¹²

With the structural and functional characteristics of hemoglobin in mind, the facility and procedures developed at LAIR were modified to increase the yield and purity of the product and the efficiency and reproducibility of the process. This paper describes the new production process, the improvements in the quality of the product, and reviews the critical changes. This information is presented as a model for the large scale production of modified hemoglobin.

II. The New Modified Hemoglobin Production Process

1. Process Overview

The production of a 20 L sterile batch of $\alpha\alpha$ Hb solution requires 30 working hours over a five day period. All processes are conducted at 5°C unless otherwise specified. On the first day, 80 units of outdated human red blood cells (RBCs) are pooled into a sterile vessel. On the second day, the RBCs are washed by cross-flow filtration with an isotonic saline solution and lysed with a hypotonic phosphate solution. The resulting hemolysate solution, which starts with 97.5% of its protein content as hemoglobin, is purified by filtration through 0.1 μ m and 500 kD filters, eliminating the stromal material. Hemoglobin is then concentrated with a 5 kD filter, removing low molecular weight impurities with the permeate. Sodium tripolyphosphate (STP) is added to the hemoglobin to increase the buffering capacity of the solution and to block competing cross-linking sites at the β -lysine-82s and β -NH₂ in the $\beta_1\beta_2$ cleft (Figures 1c and 1d). The solution is then transferred to a bioreactor. On the third day, the stroma-free hemoglobin

solution in the STP "blocking" buffer is warmed to 25°C, the solution is deoxygenated, and the hemoglobin is cross-linked with bis(3,5-dibromosalicyl) fumarate (DBBF). The cross-linked hemoglobin solution is then heat treated at 76°C and pH 6.9 for 90 minutes to selectively denature unmodified hemoglobin and inactivate harmful viruses. On the fourth day, the contents of the bioreactor, including about 750 grams of denatured protein, are filtered, oxygenated, refiltered through the 0.1 µm and 500 kD filters, and formulated in the final physiologic buffer by cross-flow diafiltration using the 5 kD filter. On the morning of the fifth day, the resulting solution is sterile packaged and frozen at -80°C. More than 70 standard operating procedures (SOPs) support facility operations by detailing facility cleaning, buffer preparation, in-process analysis, and other quality control procedures.

2. First Day Procedures

On the first day of the production process (Figure 2), 80 units of outdated human red blood cells, not more than 63 days from the date of donation, are pooled. Pooling is accomplished by transfer from the original bags into a 30 L sterile tank T0 (Alloy Products Corp., Waukesha, WI) via clinical blood administration sets with 170-260 µm nylon aggregate filters (IC8087, Baxter Healthcare Corp., IV Division, Deerfield, IL). Experience has shown that clinically incompatible blood types can be mixed and stored overnight at 5°C without lysis.

3. Second Day Procedures

On the second day (Figure 2), 20 L of 0.9% w/v sodium chloride (isotonic saline) is added to the 100 L tank T1 (DCI Inc., St. Cloud, MN) to prime the 0.45 µm filter bank A (CFP4-E-55 SMO, A/G Technology Corp., Needham, MA). The priming volume is circulated by pump P1 (Model 60, Waukesha Fluid Handling, Waukesha, WI) in the closed circuit consisting of

valve V1, 0.45 μm filter bank A, valve V2 and tank T1. The pooled cells (~20 L) are then added to the 20 L priming volume in T1. The cells are washed with isotonic saline, and the plasma proteins are removed with the permeate of filter bank A. A constant volume of 40 L is maintained with the addition of isotonic saline into T1. Washing of the red blood cells is complete when no albumin is spectrophotometrically detected at a wavelength of 280 nm in the permeate of filter bank A. 200 L of isotonic saline is sufficient to accomplish the RBC washing.

Washed cells are then lysed by adding hypotonic 10 mM phosphate buffer at pH 7.60 (lysis buffer) through valve V3 into tank T1 while maintaining the constant 40 L volume. Valves V1 and V2 are then switched to bypass filter bank A, and the lysed cells are pumped with pump P1 through valve V1, the 0.1 μm filter bank B (CFP-1-E-55SMO, A/G Technology Corp., Needham, MA), valve V2, and back into tank T1. The hemoglobin contained in the permeate from filter B flows into the 100 L tank T2 (DCI Inc., St. Cloud, MN) while the retentate containing the RBC membranes flows back to tank T1. Lysing continues until ≤ 0.5 g/dl hemoglobin is detected¹³ in tank T1. Upon completion of lysing, valve V3 is switched and lysis buffer is added directly to tank T2 to sustain a minimum circulation volume. Purification of the hemoglobin continues by circulation through pump P2 (Model 30, Waukesha Fluid Handling, Waukesha, WI) through the 500 kD filter bank C (UFP-500-E-55SMO, A/G Technology Corp., Needham, MA) and back into tank T2. The hemoglobin contained in the permeate from filter bank C flows into the 40 L tank T3 (DCI Inc., St. Cloud, MN) and the retentate containing high molecular weight (>500 kD) impurities returns to tank T2. Further purification and concentration occur by pumping the solution in tank T3 with pump P3 (Model 60, Waukesha Fluid Handling, Waukesha, WI) through the 5 kD filter bank D (UFP-5-E-55SMO, A/G

Technology Corp., Needham, MA) and back into tank T3. Molecules <5 kD (salts, buffers, water, etc.) are discarded in the permeate of filter bank D and the hemoglobin is retained in tank T3.

The solution is concentrated to 10 g/dl of hemoglobin and weighed in T3. A solution of 20 mM STP at pH 6.50 is added to the hemoglobin in tank T3 in sufficient volume to produce an 8:1 molar ratio of STP to hemoglobin. The resulting solution is pumped with pump P4 through a 1.5 μ m prefilter PF1 (ZCPP1-1.5C, Domnick Hunter, Inc., Charlotte, NC) and 0.2 μ m bacterial filter BF1 (ZCMA1-020C-P, Domnick Hunter, Inc., Charlotte, NC) into weighing tank T4 (Alloy Products Corp., Waukesha, WI). Finally, the solution is weighed, transferred to the bioreactor, cooled to 5°C, and stirred at 200 rpm overnight.

4. Third Day Procedures

Day three of the production process (Figure 3) begins by warming the hemoglobin solution in the bioreactor BR (LSL Biolafitte, France) to 25°C to facilitate rapid deoxygenation.⁸ The headspace of BR is purged with nitrogen and the solution is deoxygenated by pumping it with pump P4 (701S, Watson-Marlow, Concord, MA) through two membrane oxygenators MO1 & MO2 (Univox, Baxter Healthcare Corp., Bentley Division, Irvine, CA) connected in series and back into the BR. Nitrogen gas flows countercurrent to the hemoglobin through MO1 and MO2 (gas to solute flow rate of 1:1) at 7 liters per minute. Oxygen removal is monitored spectrophotometrically (Model 8452A, Hewlett Packard, Palo Alto, CA) at 758 nm by means of the optical flow cell FC (Custom Sensors & Technology, St. Louis, MO). When the spectrophotometer indicates that >95% of the oxygen bound to the hemoglobin has been removed, deoxygenation is discontinued. The hemoglobin solution is then heated to 37°C. The

cross-linking reagent, DBBF, is added to the hemoglobin in 1.9:1 molar ratio as a slurry of the dry powder in 2 liters of pyrogen free water. The cross-linking reaction is allowed to proceed for three hours. Immediately following cross-linking, the pH is adjusted to 6.90 with 5N NaOH and the solution is warmed to 76°C to inactivate viruses and selectively denature unmodified hemoglobin. After 90 minutes, the solution is cooled to 5°C and stored overnight under nitrogen.

5. Fourth Day Procedures

On the fourth day (Figure 4), the contents of the bioreactor, including at least half a kilogram of suspended denatured hemoglobin and precipitated hemoglobin sludge, are filtered through a 70 µm prefilter PF2 (RM3F700H21, Pall Corp., East Hills, NY), a 10 to 3 µm depth filter DF (5580502W3, Sartorius Corp., Bohemia, NY), and collected in transfer tank T5 (Alloy Products Corp., Waukesha, WI). Hemoglobin from the holdup volumes of the filters is recovered by rinsing with 60 L of isotonic saline. The hemoglobin solution is reoxygenated by pumping countercurrent to oxygen flow through membrane oxygenator MO3 (Univox, Baxter Healthcare Corp., Bentley Division, Irvine, CA) and into tank T1. Purification is accomplished by repeating the cross-flow filtration from day two in the cascading pumped loops formed by tank T1 and filter bank B, tank T2 and filter bank C, and tank T3 and filter bank D. Twenty liters of pyrogen free water is added to each of tanks T1 & T2 at the end of their respective portions of the filtration to maximize hemoglobin recovery from the holdup volume. Phosphate and other low molecular weight solutes are removed in the permeate of filter bank D with 200 L of isotonic saline added to tank T3. Final formulation is accomplished by concentrating the solution over filter bank D to 10 g/dl followed by cross-flow diafiltration with 140 L of Ringers' acetate. The

permeate from filter bank D of both buffers is discarded. The cross linked hemoglobin is then pumped with pump P4 through a 1.5 μm prefilter PF3 (ZCPP1-1.5C, Domnick Hunter, Inc., Charlotte, NC), a 0.2 μm bacterial filter BF2 (ZCMA1-020C-P, Domnick Hunter, Inc., Charlotte, NC), and collected into a storage vessel where it is stored overnight at 5°C.

6. Fifth Day Procedures

On the fifth day the hemoglobin is packaged. The storage vessel is brought from the refrigerator to a biological safety cabinet and connected to a sterile bag filling system composed of tubing and bags, a variable-flow peristaltic pump, a digital scale, hemostats, bag seals, and crimpers. The $\alpha\alpha\text{Hb}$ is pumped into sterile, nonpyrogenic biological storage bags (RCM-93A-4-MLL, Stericon Inc., Broadview, IL) in 100 ml and 250 ml quantities, sealed, and labeled. The $\alpha\alpha\text{Hb}$ bags are placed in bubble-wrap envelopes, boxed, and frozen at -80°C.

7. Quality Control and Management

A Hemoglobin Production Committee, the authors, directed the changes in the production process and agreed to use current good manufacturing practice (cGMP) as their goal. More than seventy standard operating procedures (SOPs) were written including eight defining requirements for and the handling of source blood and other raw materials, 19 describing equipment operation and maintenance, 14 detailing production procedures, seven describing cleaning procedures, eight specifying documentation and product inventory management, and 21 detailing quality control laboratory procedures. Process control analytical chemistry and final analysis for batch release were done in a dedicated laboratory. Oxygen equilibrium curves, anion exchange chromatography, and rabbit pyrogen testing were performed in separate laboratories.

III. Results

The new process for producing modified hemoglobin yields four kinds of benefits. First, the total yields of modified hemoglobin produced in each production run has increased. Second, the specificity of the process to produce the desired product, human hemoglobin cross-linked correctly but not otherwise modified, has increased. Third, contaminants are reduced. Fourth, the cost of the process in regards to the value of materials added and the labor required has decreased.

Figure 5 shows the mass of hemoglobin at several points in the modified hemoglobin production process as performed at the Letterman Army Institute of Research (LAIR) in 1991-1992 and at the Walter Reed Army Institute of Research (WRAIR) in 1996. Yield as a fraction of the initial mass of hemoglobin has increased from 33 to 58%.

Figures 6a and 6b are anion-exchange fast performance liquid chromatograms of hemoglobin produced before and after the process changes. The dominant peak eluting at four minutes is the desired product, human hemoglobin cross-linked with fumarate between the α -lysine-99s but not otherwise modified. In figure 6a, the peak eluting at three minutes is uncross-linked hemoglobin. The peaks to the right of the dominant peak in both figures are hemoglobin cross-linked between the α -lysine-99s and further modified product with additional fumarate residues at the β chain terminal amino group (β -NH₂), β -lysine-82, or cross-linking β -NH₂ and β -lysine-82 in the same β -chain. As can be seen, uncross-linked hemoglobin has been essentially eliminated and the proportion of the desired product has been increased from 50 to 90+%.

Contamination of human derived hemoglobin solutions can arise from the source blood, from materials purposely added in the hemoglobin purification and modification process, from

microbiologic growth, from materials leached from the walls of production vessels, and from the breakdown products of hemoglobin itself. Table 1 shows, that in comparing the old and new processes, the concentrations of organic phosphate from red blood cell membrane phospholipids, free iron from hemoglobin breakdown and tank walls, bacterial endotoxin and other pyrogens, and methemoglobin are all either lower or remain acceptably low.

The cost of the process has also been reduced. Table 1 shows the savings in the use of pyrogen free water. The elimination of HEPES buffer from the cross-linking step saves \$3,000 in each production run. Implementation of engineering changes to allow fully in-place cleaning and sterilization of filters also saves about \$3,000 per run. Reduced and restructured process time has eliminated the requirement for production crew overtime, which saves an additional several thousand dollars in each production run. The improvement in run yield and reduced loss of production runs because of pyrogens results in a 125% increase in useful product per run. This yield increase and the reduced costs mean that the cost per useful gram of modified hemoglobin produced was reduced by more than 60%.

IV. Discussion

The goals of improving the modified hemoglobin production process were to increase purity and yield of the product and the efficiency and reproducibility of the process. These goals were translated into specific objectives that included 1) reducing endotoxin and pyrogen contamination, 2) eliminating non-U.S.P. materials, 3) reducing methemoglobin formation, 4) reducing the amount of uncross-linked hemoglobin formed, 5) reducing the formation of $\alpha\alpha$ -cross-linked hemoglobin that was then further modified, 6) minimizing the in process

denaturation of hemoglobin, 7) recovering hemoglobin previously lost in holdup volumes, 8) speeding red blood cell pooling and washing, 9) speeding deoxygenation and oxygenation, 10) reducing the use of expensive ingredients, 11) reducing overall production time, and 12) elimination of routine requirements for overtime. Because of the potentially conflicting nature of the objectives, and perhaps even the goals, an organization for the management of process improvement was established and a commitment to current good manufacturing procedures was made.

Review of records from production runs at Letterman in 1991 and 1992 led to the recognition that 37% of runs were lost because of contamination by pyrogens, and the most significant physical loss of the product was in the holdup volumes of tanks and tubing. Engineering solutions to these problems included the application of full sterilize-in-place capability for the cross-flow filtration system and alterations in filtration and holdup volumes. Laboratory quality control assured reproducible equipment sterility and no increase in hemoglobin denaturation with reduced fluid volumes.

Other product purity issues were addressed in the alteration of the red blood cell washing process, attention to factors reducing methemoglobin formation, elimination of HEPES buffer in the cross-linking process, and better handling of the cross-linking reagent. The changes reflect scientific, engineering, quality management, and economic decisions and are discussed separately below.

Outdated units of RBCs are now pooled into a sterile holding tank on the first day. The separation of the pooling step allows the production of stroma-free hemoglobin to take place within a single 8-hour work shift on the second day. Pooling clinically incompatible red blood

cells does not lead to agglutination or lysis or to increased concentrations of red blood cell phospholipids in the final product. Opening the RBC storage bags a day earlier caused no detectable increase in bacterial or endotoxin contamination.

To avoid methemoglobin formation, the hemoglobin modification process takes advantage of the thermodynamic stability afforded by low temperature, pH control, and deoxygenation. Engineering changes now keep the process at 5°C except for deoxygenation, cross-linking, and heat treatment. Low pH is avoided and the heat denaturation process is carried out at pH 6.9. Deoxygenation is critical for two reasons. First, it forces the hemoglobin to be in the proper configuration for cross linking between the α -lysine-99s¹⁴ and second, it prevents oxidation during the high temperature denaturation of impurities at the end of cross-linking.¹⁵ The speed of deoxygenation and reoxygenation are important because the methemoglobin produced is enhanced when hemoglobin is in the partially oxygenated state.¹⁶ Faster conversion from oxyhemoglobin to deoxyhemoglobin and back reduces the presence of unstable partially oxygenated hemoglobin. A single pass through one gas exchange membrane, a clinical membrane oxygenator with nitrogen as the gas medium, fails in removing all of the oxygen from the solution. Continual cycling through the gas exchange membrane is required for complete deoxygenation. The time required for oxygen removal has been reduced from 3 to 1.5 hr with two membrane oxygenators in series. For reoxygenation, a single pass through one gas exchange membrane with oxygen as the gas medium results in complete oxygenation, eliminating the requirement for dilution into 400 liters of oxygenated buffer. Along with the new deoxygenation and oxygenation procedures, success in gently handling the molecule has resulted in only 2-3% methemoglobin in the final product.

In published descriptions of the cross-linking of hemoglobin with DBBF, HEPES buffer was used for both its buffering capability and as a solvation medium for DBBF. However, HEPES is not a U.S.P. listed product, and its presence raises questions about its toxicity. Hemoglobin itself as well as the STP "blocking" agent are adequate buffers at the pH used (7.0) and the solvation of DBBF in HEPES prior to exposure to a hemoglobin solution is not required for the cross linking reaction.¹⁴ Therefore, HEPES buffer has been removed from the manufacturing process.

The chemical purity of the $\alpha\alpha$ -cross-linked hemoglobin product, uncontaminated by uncross-linked hemoglobin or by further modified cross-linked hemoglobin, is related to the ability to deliver the intact cross-linking agent in the correct stoichiometry under the correct conditions. To understand the optimization of the cross-linking of hemoglobin, a description of the reaction of DBBF with hemoglobin is necessary.

The intramolecular cross-linking of hemoglobin is accomplished by a nucleophilic displacement reaction involving the cross-linker, DBBF, and the side-chain of lysine. DBBF is a diester with very efficient leaving groups in the dibromo-aspirins. The side-chain amine group of lysine with its lone pair of electrons attacks one of the carbonyl groups of fumarate. The dibromo-aspirin leaves, and an amide bond is formed with the fumarate. The same nucleophilic displacement reaction occurs at the opposite end of the DBBF, yielding a final product of intramolecularly cross-linked hemoglobin.

Several factors contribute to the specificity of the cross linking between DBBF and deoxyhemoglobin. Solution conditions, protein conformation, allosteric effectors, and alternate site blockers all help to increase the yield of the cross-linking reaction.¹⁴ In addition, specific

interactions between DBBF analogues and hemoglobin have been observed with x-ray crystallography that position the DBBF optimally for cross linking at the α -lysine-99 site.¹⁷

Of the 44 lysines in hemoglobin that potentially react with DBBF, only a few are active. In analyzing the final product, only α -lysine-99, β -NH₂ and β -lysine-82 react substantially with DBBF¹⁸. The major reason for this specificity is probably the high value of the pKa of the lysine side-chain amine. With a pKa of 10.8 in aqueous solution, free lysine is highly protonated under neutral conditions. Since the reaction conditions are maintained at pH 6.9, lysines exposed to the aqueous medium are largely protonated. With a proton associated with the lone pair of electrons, lysine cannot attack the fumarate carbonyl groups of DBBF. Thus, lysines that are on the periphery of the hemoglobin molecule are unreactive toward the DBBF. Lysines buried inside the hemoglobin are simply inaccessible to the DBBF. Only α -lysine-99, β -NH₂ and β -lysine-82, all in the central cavity of hemoglobin, are accessible. The increased hydrophobic environment of the cavity favors the neutral form of lysine and effectively lowers the pKa of these lysines. With the proton now removed, these lysines can effectively react with the DBBF. The use of a β cleft blocker (STP) effectively blocks the β -NH₂ and the β -lysine-82 sites. Acidic conditions (pH <7), though potentially causing increased oxidation, must be used in order for the STP to bind efficiently within the beta cleft.

As mentioned previously, chloride and CO₂ act as allosteric effectors of hemoglobin. The chloride interaction involves several binding sites that include α -lysine-99. This reaction elevates the population of protonated lysines, rendering the amino acid inactive for the cross linking reaction. Therefore, chloride is removed from the reaction mixture.

The cross-linking reaction between α -lysine-99s only occurs with hemoglobin that is not

carrying oxygen. If oxygen is present, the hemoglobin changes conformation to its higher affinity form. In this form, the α -lysine-99s are no longer available and a different reaction occurs cross-linking the β -chains between the β -lysine-82s. This creates a modified hemoglobin that gives up oxygen less readily.¹⁹ Because of this competing reaction, the desired reaction is performed with the solution fully deoxygenated and with a blocking compound occupying the alternative cross-linking site in the space between the β -chains.

Finally, the cross-linking agent, DBBF, is unstable in water. It is susceptible to hydrolysis that can be catalyzed both by acidic or basic conditions. Since DBBF has two reactive sites, hydrolysis at one reactive site of the DBBF renders it incapable of intramolecular cross linking. However, the second unhydrolyzed reactive site of DBBF is still capable of reacting with lysine sites on the hemoglobin. Prevention of DBBF hydrolysis becomes a high priority to ensure intramolecular cross-linking and deter reactions with partially hydrolyzed DBBF. As conjugate bases and acids hydrolyze DBBF, DBBF is rapidly added to deionized pyrogen free water, and the slurry is then immediately transferred to the bioreactor to minimize hydrolysis of the cross linking reagent. Deoxygenation of the slurry is not performed because the oxygen dissolved in the pyrogen free water of the slurry, about 9 ml, would only oxygenate 0.2% of the hemoglobin and thus does not affect the process yield. In fact, the small amount of oxygen present may account for the substantial decrease in the unmodified product. Unmodified hemoglobin has a higher affinity for oxygen than $\alpha\alpha$ -cross-linked product and is more likely to bind oxygen. Oxygenated hemoglobin denatures more rapidly than deoxygenated hemoglobin.^{15,20} Therefore, the small amounts of oxygen may enhance the denaturation of undesired material. The homogeneity of the cross-linked product can be ascertained with anion

exchange FPLC (see figures 6a & 6b). By preserving the integrity of the DBBF, synthesis of pure $\alpha\alpha$ Hb as measured by FPLC has increased from 50 to 90+% with a significant increase in overall product yield.

Better understanding of the cross-linking reaction chemistry and the implementation of current good manufacturing techniques have allowed substantial increases in the purity and yield of the modified hemoglobin product. The high specificity of this reaction and the potential for further refinement was not realized until the process changes were undertaken. Making very precise chemical modifications of a globular protein is possible.

This increased understanding and control of the reaction chemistry and the production process has led to savings of time and money. Saving time feeds back into product quality by reducing the exposure of hemoglobin to denaturing environments. Saving money occurs through reduced raw material, process, and labor costs and a reduced potential for mishaps. Freed resources can be used in other parts of the development program.

This report documents the recent progress of work originally begun by Winslow and Chapman⁵ to produce a model modified hemoglobin solution of high purity to advance the development of oxygen-carrying resuscitation fluids. It shows that cGMP production of biological material can be carried out effectively and efficiently in the public sector. It shows the potential for very specific and high yield chemical modification of hemoglobin.

References

1. Winslow RM. Hemoglobin-based Red Cell Substitutes. John Hopkins University Press, Baltimore, MD, 1992.
2. Rudolph AS. Encapsulation of Hemoglobin in Liposomes. In: Blood Substitutes: Physiological Basis of Efficacy, Birkhäuser Boston, Ann Arbor, MI, 1995.
3. Regan RF, Panter SS. Neurotoxicity of hemoglobin in cortical cell culture. *Neurosci Lett* 1993 Apr 30;153(2):219-22.
4. Manning LR, Jenkins WT, Hess JR, Vandegriff K, Winslow RM, Manning JM. Subunit Dissociations in Natural and Recombinant Hemoglobins. *Protein Sci* 1996;5:775-781.
5. Winslow RM, Chapman KW. Pilot-Scale Preparation of Hemoglobin Solutions. In: *Methods in Enzymology Vol. 231, Hemoglobins Part B: Biochemical and Analytical Methods*, Academic Press, San Diego, CA, Everse J., Vandegriff KD, Winslow RM, eds. 1994:3-16.
6. Dickerson RE, Geis I. Hemoglobin: Structure, Function, Evolution, and Pathology. The Benjamin/Cummings Publishing Company, Inc., Menlo Park, CA, 1983.
7. Hill AV. The possible effects of the aggregation of the molecules of hemoglobin on its oxygen dissociation curve. *J Physiol Lond* 1910; 40:4-7.
8. Imai K. Allosteric effects in hemoglobin. Cambridge University Press, New York, 1982.
9. Nagel RL, Gibson QH. The Binding of Hemoglobin to Haptoglobin and its relation to Subunit Dissociation of Hemoglobin. *J Biol Chem* 1971; 246(1):69-73.
10. Ip SHC, Johnson ML, Ackers GL. Kinetics of Deoxyhemoglobin Subunit Dissociation Determined by Haptoglobin Binding: Estimation of the Equilibrium Constant from Forward and Reverse Rates. *Biochemistry* 1976; 15(3):654-660.

11. Walder, RY, Andracki ME, Walder JA. Preparation of Intramolecularly Cross-Linked Hemoglobins. In: Methods in Enzymology Vol. 231, Hemoglobins Part B: Biochemical and Analytical Methods, Academic Press, San Diego, CA, Everse J., Vandegriff KD, Winslow RM, eds. 1994:274-280.
12. Faassen AE, Sundby SR, Panter SS, Condie RM, Hedlund BE. Hemoglobin: A Lifesaver and an Oxidant. How to Tip the Balance. Biomat, Art Cells, Art Org 1988;16(1-3):93-104.
13. International Committee for Standardization in Haematology. Recommendations for reference method for haemoglobinometry in human blood (ICSH Standard EP 6/2: 1977) and specifications for international haemoglobin cyanide reference preparation (ICSH Standard EP 6/3: 1977). J Clin Pathol 1978; 31:139-143.
14. Chatterjee R., Welty EV, Walder RY, Pruitt SL, Rogers PH, Arnone A, Walder JA. Isolation and Characterization of a New Hemoglobin Derivative Cross-linked between the α Chains (Lysine 99 α_1 -> Lysine 99 α_2). J Biol Chem 1986; 261:9929-9937.
15. Estep TW, Bechtel MK, Miller TJ, Bagdasarran A. Virus Inactivation in Hemoglobin Solutions by Heat. Biomat, Art Cells, Art Org 1988;16(1-3):129-134.
16. Abugo OO, Rifkind JM. Oxidation of hemoglobin and the enhancement produced by nitroblue. J Biol Chem 1994 Oct 7;269(40):24845-53.
17. Perutz MF, Fermi G, Abraham DJ, Poyart C, Bursaux E. Hemoglobin as a Receptor of Drugs and Peptides: X-ray Studies of the Stereochemistry of Binding. J Amer Chem Soc 1986, 108:1064-1078.
18. Jones RT. Structural Characterization of Modified Hemoglobins. In: Methods in Enzymology Vol. 231, Hemoglobins Part B: Biochemical and Analytical Methods, Academic Press, San

Diego, CA, Everse J., Vandegriff KD, Winslow RM, eds. 1994:322-343.

19. Walder JA, Walder RY, Arnone A. Development of Antisickling Compounds that Chemically Modify Hemoglobin S Specifically within the 2,3-Diphosphoglycerate Binding Site. *J Mol Biol* 1980; 141:195-216.

20. Olsen KW. Thermal Denaturation Procedures for Hemoglobin. In: *Methods in Enzymology* Vol. 231, Hemoglobins Part B: Biochemical and Analytical Methods, Academic Press, San Diego, CA, Everse J., Vandegriff KD, Winslow RM, eds. 1994:514-524.

Table Caption:

Table 1 - Comparative analytical results obtained for hemoglobin productions runs acquired at Letterman Army Institute of Research (old process) and at Walter Reed Army Institute of Research (new process). Data for old process is taken from either reference (5) or is the average value from at least three productions runs. Data for the new process is the average of four production runs.

Figure Captions:

Figure 1 - Schematic of Hemoglobin and its modification. a) Hemoglobin is a tetrameric globular protein composed of two alpha (α) and two beta (β) chains. The chains are not covalently held together. At high concentrations, the tetramer dominates while at low concentrations the heterodimer is favored. b) There are two sites where the compound bis(3,5-dibromosalicyl) fumarate (DBBF) can covalently cross-link (shown as ■), β -lysine-82 to β -lysine-82 and α -lysine-99 to α -lysine-99. Deoxygenated hemoglobin favors cross linking between the two α -lysine-99s. In addition, the β -lysine-82 sites can be blocked with sodium tripolyphosphate (STP), optimizing the desired product $\alpha\alpha$ -cross-linked hemoglobin. c) Oxygenated hemoglobin will primarily cross link between the two β -lysine-82s, forming $\beta\beta$ -cross-linked hemoglobin. d) Extra DBBF can react with other lysine sites such as a univalent linkage to the β chain terminal amino group (β -NH₂).

Figure 2 - Process and Flow Diagrams for Days 1 & 2. Red blood cells are pooled, washed, and lysed. Cell fragments are removed by stepwise filtration, generating stroma-free hemoglobin solution.

Figure 3 - Process and Flow Diagrams for Day 3 - Stroma-free hemoglobin is cross-linked with DBBF, yielding $\alpha\alpha\text{Hb}$. Heat treatment accomplishes both pasteurization and purification of the cross-linked product.

Figure 4 - Process and Flow Diagrams for Day 4 - $\alpha\alpha\text{Hb}$ is filtered stepwise through the cross flow filtration system, removing particulate matter and producing the final $\alpha\alpha\text{Hb}$ product.

Figure 5 - Hemoglobin Production Yields - Overall product yield has increased from 33% to 58%. Total hemoglobin amounts are measured after RBC pooling on day two at T0 (Figure 2), on day two at T4 (Figure 2) for stroma-free hemoglobin, on day four at T1 (Figure 4) after crosslinking and heat treatment, and on day five at final filling and storage.

Figure 6 - FPLC data on lot #950207 (prior to changes) and lot #960416. Analysis was carried out on a Pharmacia FPLC system using a mono Q HR 5/5 column at a flow rate of 1.0 ml/min. The absorbance of the eluent was measured at 405 nm with the Pharmacia on-line mercury lamp detection system with a 5 mm optical flow cell. The system was equilibrated with buffer A consisting of 20 mM Tris acetate at pH 8.3. The sample was loaded in a 100 μl volume and eluted with a gradient of 0-20% buffer B (20mM Tris acetate, 1.0 M NaCl) over 20 minutes (or 1%/min). The major fraction, $\alpha\alpha\text{Hb}$, elutes at 4 minutes.

Table 1 - Comparison of Batches of Cross-Linked Hemoglobin Solution

Parameter (Units)	Old Process ⁵	New Process
Hemoglobin (g/dl)	9.8	9.95
Methemoglobin (%)	7.5	3.20
Total Yield (%)	33	58
pH	7.56	7.39
Sterility	Pass	Pass
Rabbit Pyrogen Test (% pass)	62.5	100
Total Phosphate ($\mu\text{g/ml}$)	<1	0.75
Free Iron ($\mu\text{g/ml}$)	4.2	4.57
Pyrogen free water used (L)	1897	1197
Total labor (hrs)	180	132

FIGURE 1

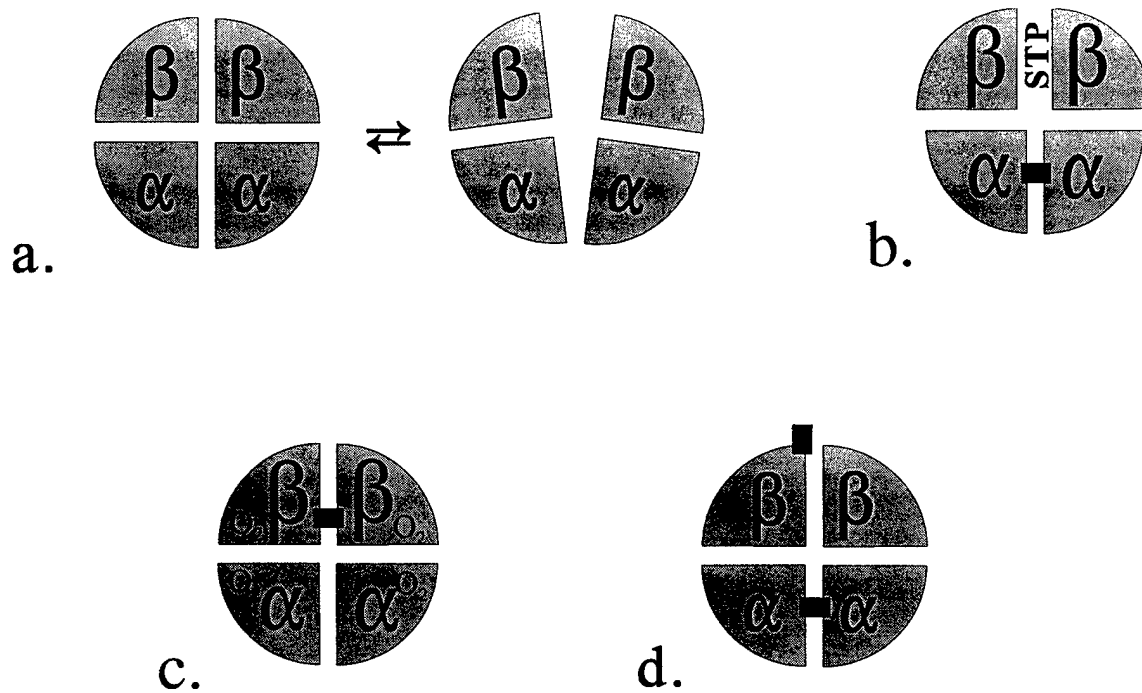

FIGURE 2

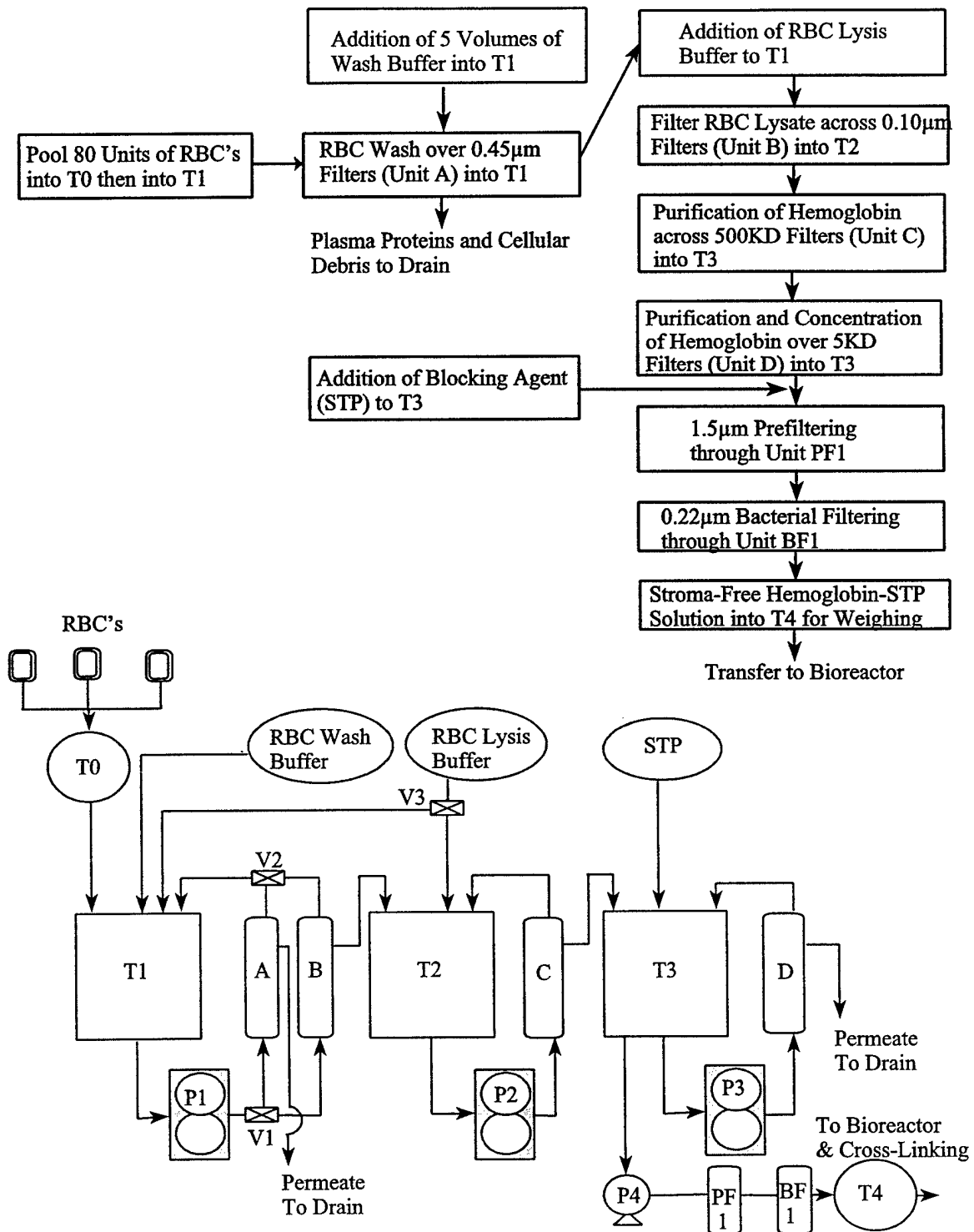

FIGURE 3

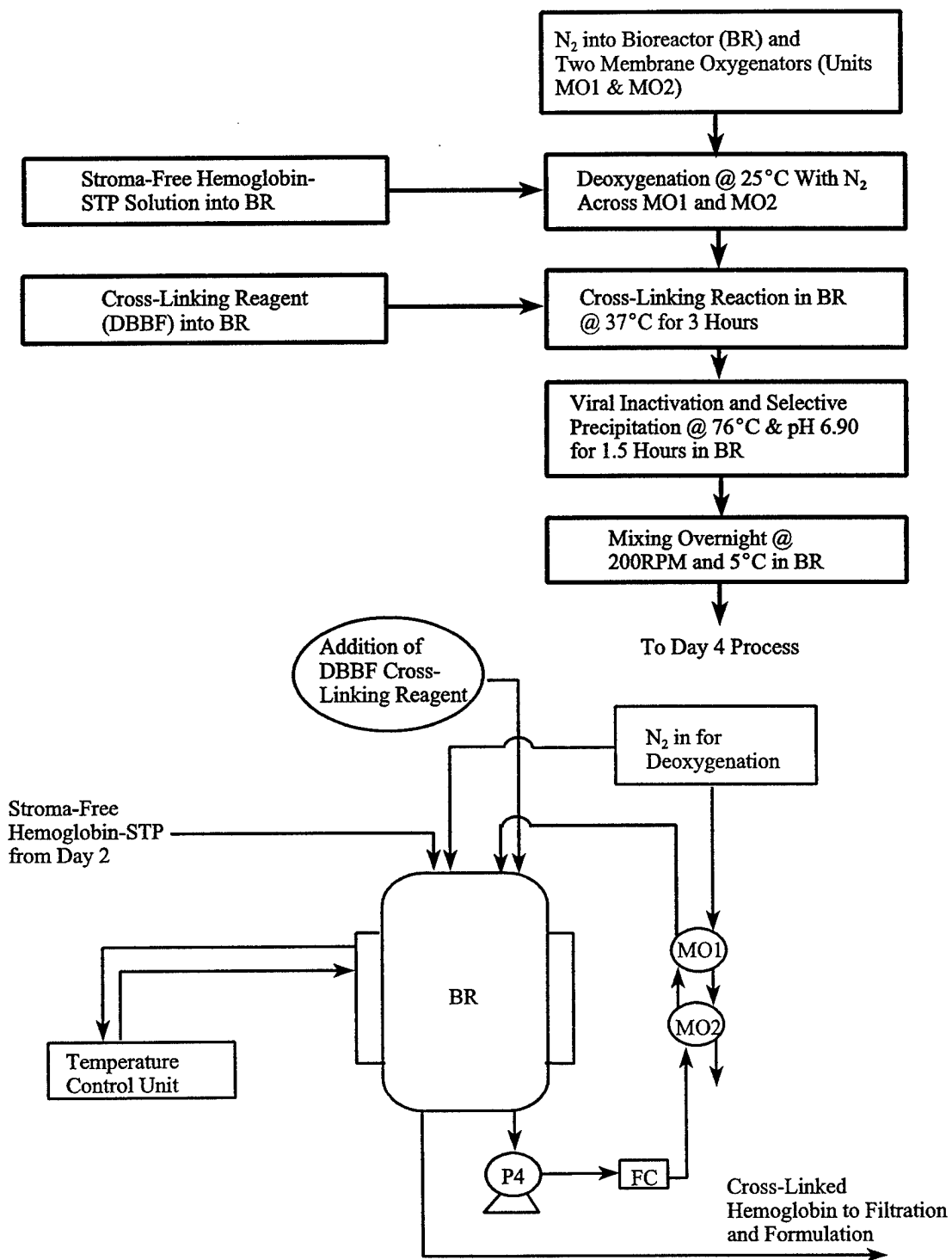

FIGURE 4

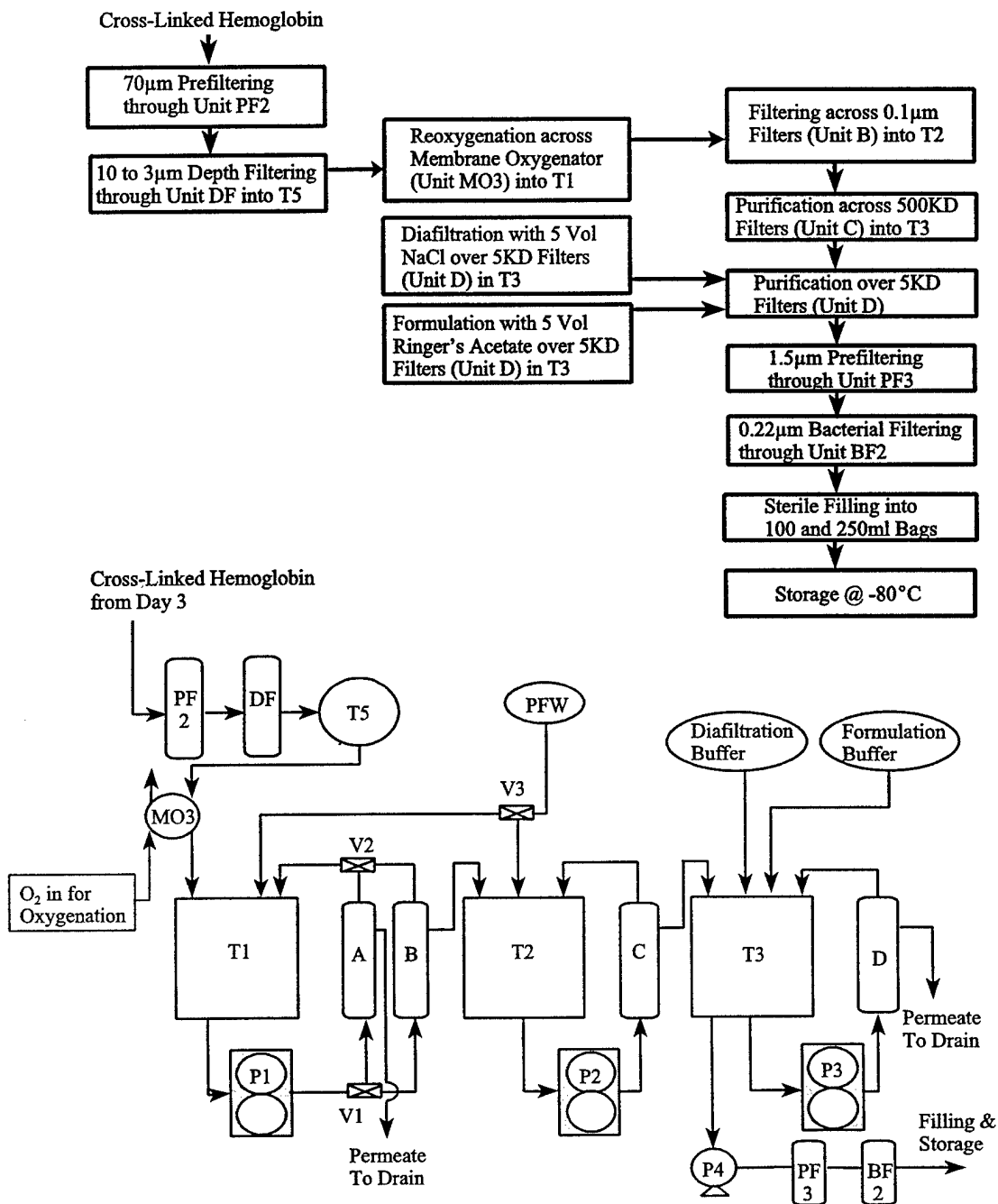

FIGURE 5

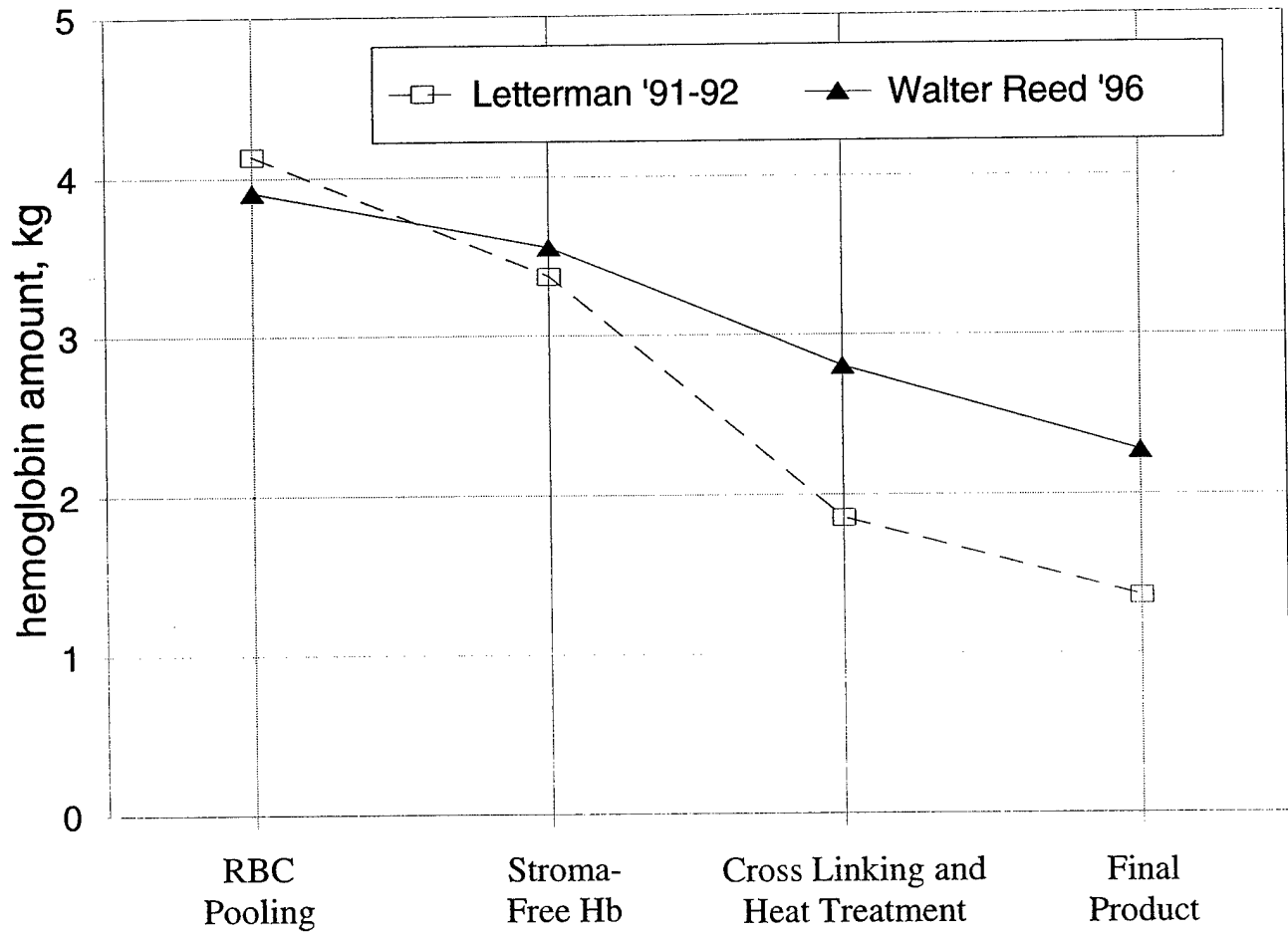
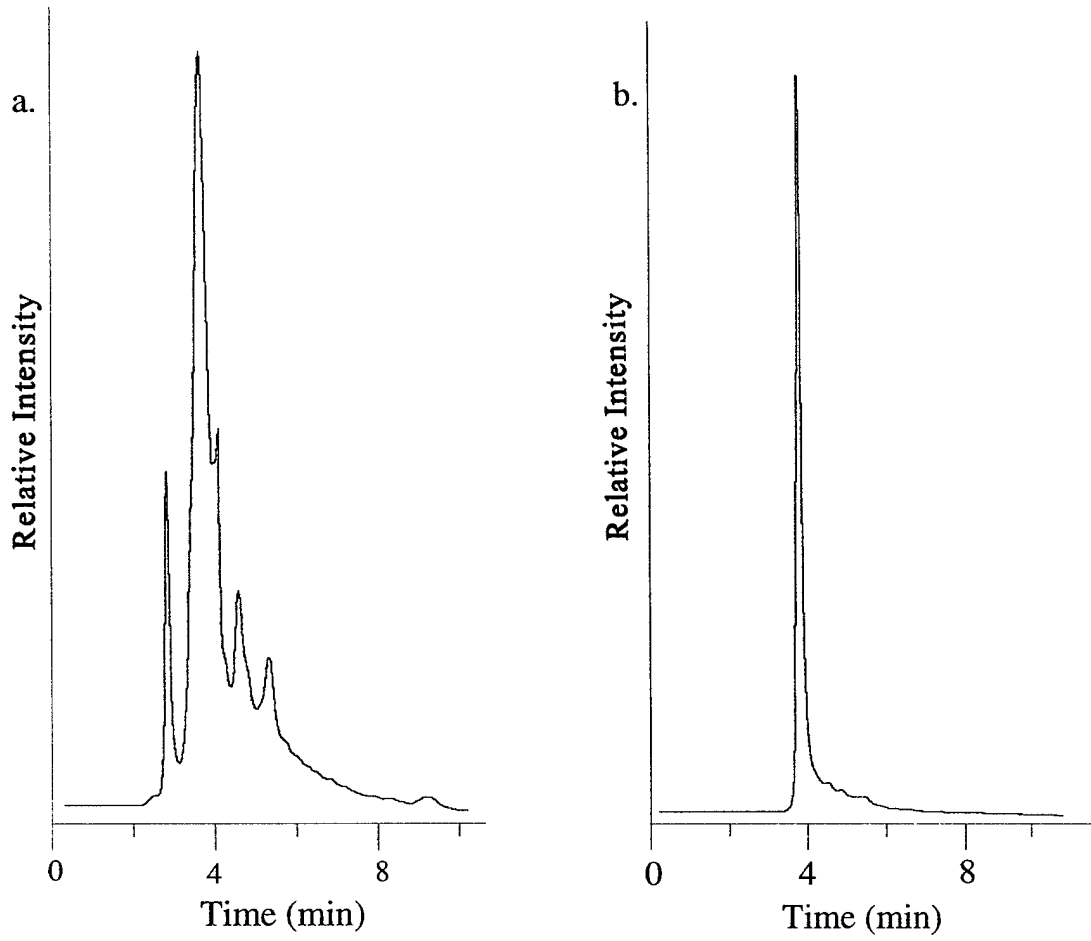

FIGURE 6



STABILITY STUDY DATA

Lot Number: 960123-00-X

Temperature: 25°C

Assay/ Date	0 Time	2 week	4 week	2 months	4 months	6 months	9 months	1 year	15 months	18 months	21 months
Hb (g/dl)	7.96	8.14	8.13								
MethHb (%)	3.53	68.4	87.25								
p50 (Torr)	26.0	14.5	10.9								
pH	7.21	7.47	7.42								
HPLC (%)	>95	>95	>95								
Free Iron (µg/ml)	4.45	7.54	10.19								
LAL (EU/ml)	0.25	0.25	0.25								

Testing after 4 weeks has ceased. All materials have been destroyed.

February 22, 1996

STABILITY STUDY DATA

Lot Number: 960123-00-X

Temperature: 4°C

Assay/ Date	0 Time	2 week	4 week	2 months	4 months	6 months	9 months	1 year	15 months	18 months	21 months
Hb (g/dl)	7.96	8.10	7.80	8.14	8.26						
MethHb (%)	3.53	5.23	6.90	11.49	23.03						
p50 (Torr)	26.0	28.3	27.5	31.25	19.25						
pH	7.21	7.29	7.22	7.28	7.21						
HPLC (%)	>95	>95	>95	>95	>95						
Free Iron (µg/ml)	4.45	4.10	6.96	6.76	6.70						
LAL (EU/ml)	0.25	0.50	0.50	0.25	0.25						

Testing after 4 months has ceased. All materials have been destroyed.

June 4, 1996

STABILITY STUDY DATA

Lot Number: 960123-00-X

Temperature: -80°C

Assay / Date	0 Time	2 week	4 week	2 months	4 months	6 months	9 months	1 year	15 months	18 months	21 months
Hb (g/dl)	7.96	8.30	8.15	7.99	7.89	8.14					
MetHb (%)	3.53	3.20	3.71	3.59	3.91	4.24					
p50 (Torr)	26.0	28.9	29.4	32.8	26.4	24.9					
pH	7.21	7.28	7.23	7.26	7.17	7.20					
HPLC (%)	>95	>95	>95	>95	>95	>95					
Free Iron (µg/ml)	4.45	3.54	5.02	7.43	5.41	5.08					
LAL (Eu/ml)	0.25	0.50	0.50	0.25	0.25	0.50					

List of Personnel

The following personnel received pay from the negotiated effort during part or all of the report period:

Project Manager: Lloyd E. Lippert

Secretary: Kristin Lamberger

Research Technologist: Claudia Derse-Anthony and Michael Mechling

Production Team Chief: Christine Driscoll

Process Development Engineer II: Frank Highsmith and Thomas Forgacs

Process Development Engineer I: Brain Chung and Christopher Catino

Sterile Process Operator: Sami Cardak

Sterile Process Assistant: Katherine Franklin

Analytical Laboratory Technician: Christy Sasiela

Analytical Laboratory Assistant: Theresa Beyerle