

**O
T
S
D**

AR-009-753
DSTO-RR-0089

Neural Networks for
Automatic Recognition of
Military Deployment Templates

Richard Price and Katrina Kerry

APPROVED FOR PUBLIC RELEASE

© Commonwealth of Australia

DTIC QUALITY INSPECTED 4

DEPARTMENT OF DEFENCE
DEFENCE SCIENCE AND TECHNOLOGY ORGANISATION

THE UNITED STATES NATIONAL
TECHNICAL INFORMATION SERVICE
IS AUTHORISED TO
REPRODUCE AND SELL THIS REPORT

Neural Networks for Automatic Recognition of Military Deployment Templates

Richard Price and Katrina Kerry

Information Technology Division
Electronics and Surveillance Research Laboratory

DSTO-RR-0089

ABSTRACT

A key function in tactical intelligence, is the ability to recognise patterns of behaviour in opposing force activities. Deployment templates are patterns that define the spatial layout opposing force units are known to employ, when carrying out a range of different operations. The early detection of these patterns, provide key indicators to intelligence analysts, for predicting future opposing force activities. In this paper, we investigate the use of neural networks to automatically detect deployment templates, when given full or partial opposing unit positional information.

The spatial template recognition problem is a subset of many spatial pattern recognition problems found throughout defence, and the demonstrated success of this approach, could have important military implications beyond this particular application.

APPROVED FOR PUBLIC RELEASE

DEPARTMENT OF DEFENCE

DEFENCE SCIENCE AND TECHNOLOGY ORGANISATION

19961217 072

Published by

*DSTO Electronics and Surveillance Research Laboratory
PO 1500
Salisbury. South Australia, Australia 5108*

*Telephone: (08) 259 5555
Fax: (08) 259 6567*

*© Commonwealth of Australia 1996
AR-009-783
August 1996*

APPROVED FOR PUBLIC RELEASE

Neural Networks for Automatic Recognition of Military Deployment Templates

EXECUTIVE SUMMARY

A key function in tactical intelligence, is the ability to recognise patterns of behaviour in opposing force activities. Deployment templates are patterns that define the spatial layout opposing force units are known to employ, when carrying out a range of different operations. The early detection of these patterns, provide key indicators to intelligence analysts, for predicting future opposing force activities. In this paper, we investigate the use of neural networks to automatically detect deployment templates, when given full or partial opposing unit positional information. When applying pattern recognition techniques to this problem a range of potential problems need to be considered. The sightings on the ground may well differ from the template positions due to terrain, many opposing force unit positions will not be known, causing the patterns to be incomplete, and the template may be rotated at any angle. We show that a neural network approach can handle all of these problems and recommend the approach for further investigation. The spatial template recognition problem is a subset of many spatial pattern recognition problems found throughout defence, and the demonstrated success of this approach, could have important military implications beyond this particular application.

Authors

Richard Price

Information Technology Division

Dr Richard Price is the task manager of a project researching advanced techniques to support land based tactical intelligence processing. His research interests include neural networks, genetic algorithms, numerical optimisation and pattern recognition.

Katrina Kerry

Information Technology Division

Katrina Kerry is an Honours student studying Mathematics and Computer Science at the University of Adelaide. Her current interests are in software engineering tools and environments, software verification and artificial intelligence. This work was conducted whilst being employed as a vacation student at DSTO.

Contents

1. The Problem and its Defence Significance	1
2. The Approach.....	1
3. Neural Network Topology and Training	3
4. Doctrinal and Situational Deployment Templates - The Perturbation Problem	4
5. The Missing Data Problem.....	6
6. The Rotation Problem	8
7. The Permutation Problem.....	10
8. False Alarms.....	11
9. Scanning The Battlefield.....	12
10. Results For Examples Containing Combinations of Perturbation, Missing Data and Rotated Templates.....	12
11. Conclusions	14
References	15
Appendix A.....	17

1. The Problem and it's Defence Significance

Military spatial deployment templates are used by intelligence analysts as decision support aids to ascertain an opposing force's aims and intentions. In the tactical land based scenario, superior army units will tend to deploy their subordinate units on the ground, according to patterns that are designed to be appropriate for the particular operation being carried out.

Trained intelligence analysts are skilled at scanning a battlefield containing known opposing force positions, and detecting which pattern is being deployed. Once a template has been recognised, this information is used as an indicator by the analyst, as to the future possible opposing force movements.

In warfare, deception is a vital part of a commander's strategy, and care must be taken by the analyst not to read too much in to one indicator in isolation, however the detection of spatial templates is an important aspect of the intelligence function.

Although spatial templates have been used in traditional approaches to intelligence for many years, they also form a major part of a relatively new approach to the intelligence problem called Intelligence Preparation of the Battlefield (IPB). IPB was originally developed by the US Army and has subsequently been adopted by many armies throughout the world. In this paper we shall report on work carried out to automatically identify spatial deployment templates from an electronic map, using neural network technology.

2. The Approach

A spatial template will exist for a particular superior unit carrying out a particular operation. The spatial template depicts how the superior unit is likely to deploy its subordinate units for a standard operation [2]. Typically, for each superior unit there will be a range of templates for between five and ten different standard operations. For security reasons, we are unable to report on actual deployment templates for real forces. Therefore, a range of five fictitious templates were created for reporting purposes, based on a fictitious template for an army brigade, carrying out the operation of defending ground.

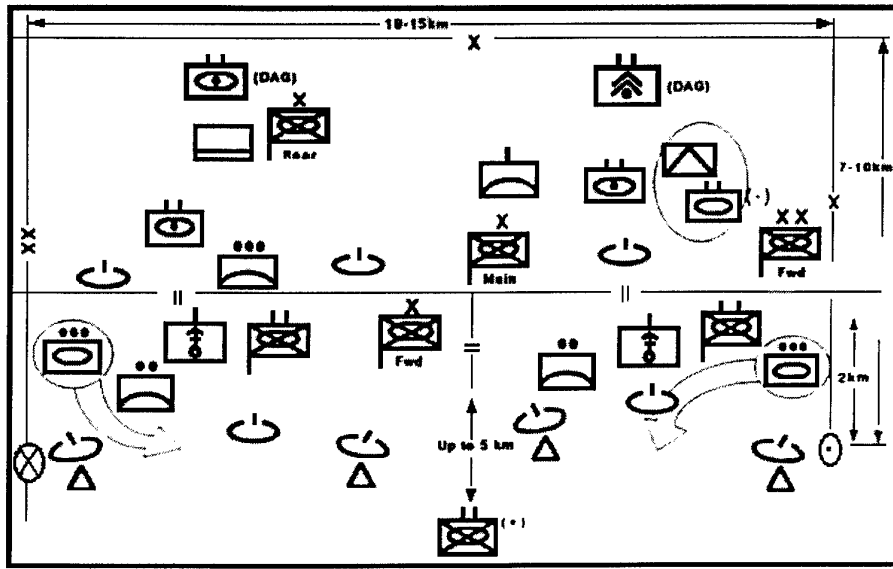

Figure 1. An Example of a Fictitious Deployment Template for a Brigade Defending Ground.

One might ask why are armies so predictable in the way they deploy? The reasons for this arise out of the logistics involved in deploying several hundreds, and may be thousands of soldiers. In order to carry out precise manoeuvres in the field, each subordinate unit needs to know how it is expected to deploy. In peace time each unit will be trained to deploy in doctrinal form. Therefore, when deployed in combat, it is likely to carry out its business in the way it has been trained, rather than in an unfamiliar manner.

Furthermore, particular operations require lateral support between subordinate units within the template, and therefore these units must be deployed close to each other. Opposing forces may well employ a deception plan, in an attempt to distract attention from their main activity. A unit may well deploy in a pattern indicating a particular intention, but actually carry out a different operation. However if intelligence staff can use technology to help detect strengths of match, it may well help to detect real from deceptive deployment patterns.

To be able to enter a spatial deployment template into a neural network, an encoding convention needs to be established. The adopted convention encoded each unit as a triplet. The first two elements of the triplet were the X,Y offset from the centroid of the template, and the third element was a number denoting the type of unit. In the brigade example shown in fig. 1, there are 22 units in the template, however only 14 distinct types of units belonging to the brigade (where the type of unit is denoted by a unique map symbol). Therefore the third element of the triplet was a number ranging between 1 and 14. It should be noted that each template for a brigade will consist of the same 22 subordinate units, however they will be arranged differently according to the specific requirements of the operation. The neural network therefore had 66 input nodes and 5 output nodes. The encoding for the output nodes required a 1 in the first node and a 0 in the other four output nodes, if template number one was the desired output. If the

second template was the desired output, the desired output string would be 0 1 0 0 0, and so on. An important point to consider is the ordering of the triplets within the input string. The adopted convention was that units of type 1 were first in the input string. Any template will generally have more than one unit of a particular type, however it is uncommon for there to be more than three units of any one type, belonging to a superior unit. Since the same template could be represented with the units of the same type, in any order, in the input string, the testing set must contain all combinations of the possible orderings, for replicated unit types. This point will be addressed further in a later section.

3. Neural Network Topology and Training

The neural network package used for this work was the Neurogenetic Optimiser from BioComp Systems Inc. This package uses genetic algorithms to help select optimal neural network topologies. Each neural network attribute (e.g paradigm, number of hidden layers and nodes, learning rate, transfer function etc.) are encoded into a binary string, which is optimised using a genetic algorithm, minimising an objective function of best fit, against the training and test data. This allows the system to generate many neural networks during training, and only proceed with the best networks that demonstrate good generalisation properties against the test and training data.

Using genetic algorithms to define the neural network topology, recognises that training a neural network is a two phase optimisation process. The first optimisation process, is the minimising of the least squares error function over all the output nodes and training sets. The second optimisation process, is the minimisation of the goodness of fit error objective function, overall possible neural networks, against the training and test data.

The traditional approaches for training neural networks, automate the first optimisation problem using first order methods such as steepest descent, although better results are now being reported, using more sophisticated optimisation algorithms such as conjugate gradients ref[5]. However trial and error is the most common approach adopted to solve the second optimisation problem, which has turned training robust neural networks into more of a black art, than an exact science.

Using genetic algorithms to solve the second optimisation problem, reduces the black art component in training, improves the generalisation properties of the neural networks, and importantly, cuts down the development time to produce robust solutions. The reduction in development time, and hence development costs, is caused by replacing the human time and effort in training, monitoring and testing individual networks, with computer processing time. Since the computer is automatically generating many networks, and only proceeding to mutate with those that possess the desired generalisation properties, it is following the same general process usually adopted by the human, but in an automated and more scientifically rigorous fashion.

When testing a neural network's performance, a definition for a classification had to be defined. A classification was defined to exist, when the largest valued output node was greater than 0.5, and the difference between the largest valued output node and the next largest, was greater than 0.2. If this state did not exist, the network was defined to be offering no classification. This rule was created in a heuristic fashion, and can only be applied to problems such as classification, where all the output nodes have desired values of zero, apart from the output node defining the classification, whose desired value should be unity.

4. Doctrinal and Situational Deployment Templates - The Perturbation Problem

The spatial templates referred to so far, are more correctly termed doctrinal spatial templates since they are the theoretical templates for that particular opposing force. However physical constraints may well cause a subordinate unit to perturb a template, when deployed in the field. For example, mountainous terrain or marshy ground are unsuitable for deployment, and will be avoided. The units will most likely deploy close to the doctrinal position, but not strictly in accordance with it. Current research is also addressing the automatic detection of these situations, by looking at terrain data, and suggesting the most likely positions for deployment.

When an opposing force unit is deployed in the field, the perturbed template taking into account the current physical constraints, is known as the situational template. The adopted approach was to train a neural network for a particular superior unit, on the full range of possible doctrinal templates for that unit, where each template corresponds to an operation it may be asked to carry out, and test that network on examples which have been perturbed by fixed amounts. The perturbed templates are therefore representing the situational templates, the network would be expected to classify, when used in anger. Since neural networks have proved successful for many noisy pattern classification applications, it was viewed as a suitable approach for this problem.

A sensitivity analysis was performed to ascertain how successful a fully trained network was, at classifying perturbed examples of each doctrinal template. The perturbations were performed over two dimensions. An incremental percentage of the 22 units were perturbed by incremental amounts of $\pm \delta$, where δ was arbitrarily fixed at 500 metres. The results presented in Fig. 2 (over page) show the average percentage classification across all five templates, when all templates were perturbed by multiples of $\pm \delta$.

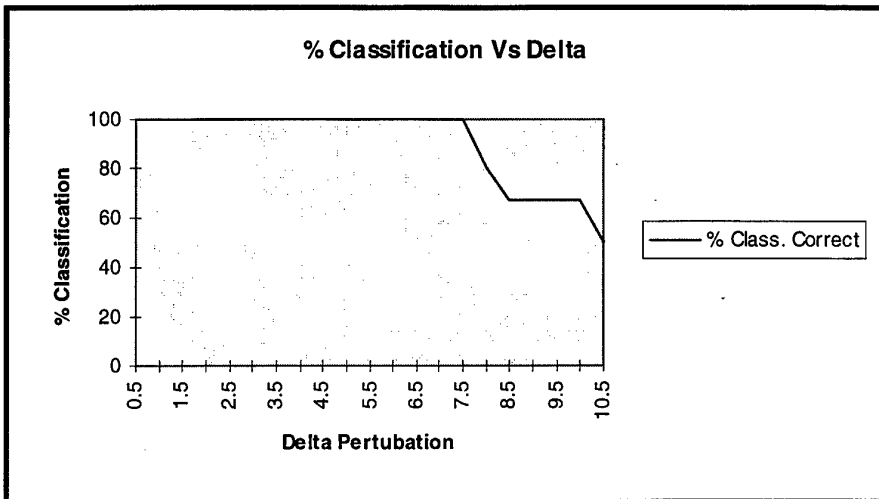

Figure 2. A Graph Showing Average Percentage Classification Against Perturbations of Delta.

The results in Fig. 2 show that the trained neural network demonstrated a robustness when attempting to classify perturbed templates. The graph shows that 100% classification was still achieved, when the average absolute displacement over all the units in all the templates was $\leq 7.5 \cdot \delta$ or 3.75 km. However performance degrades to 50% very quickly beyond this point. It should be noted that when viewing Fig.2 that out of the 105 example templates presented to the neural network, it offered a classification for 91 of them of which 85 were correct, giving an overall classification rating of 93%. From Fig 1. it can be seen that 3.75 km is about a quarter of the width of the overall template, and therefore is an acceptable distance for classification not to occur.

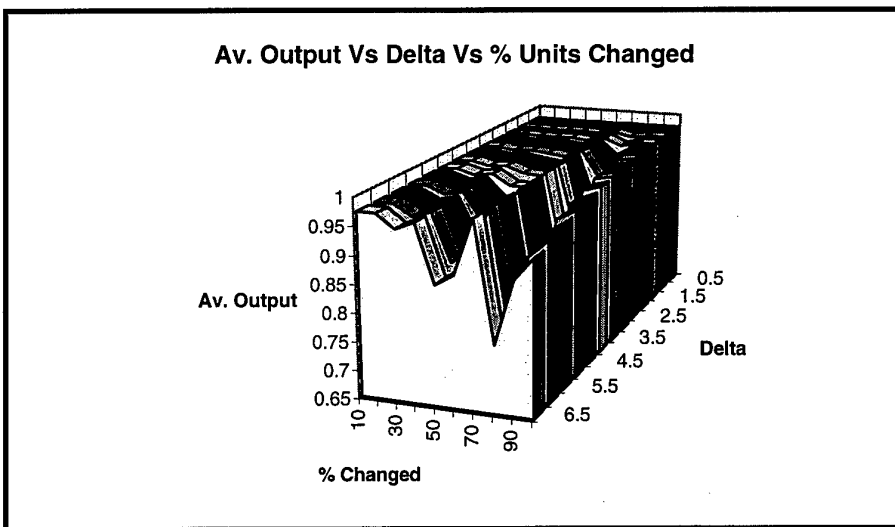

Figure 3. A 3-D Graph to Show Average Desired Output Against Perturbations of Delta Against Percentage of Units Changed.

In Fig.3 average output is the average value overall input patterns for the non-zero node, that determines the classification for that pattern. Therefore the desired values for all the patterns in Fig3. are unity. The major valley in the graph, illustrates the expected degradation from unity, of the average output value, as delta and the percentage of units changed is increased. However the average of the output values is still around 0.85-0.9 after 50% of the units have been perturbed by $6 \cdot \delta$ or 3 km. However, in an attempt to explain why the graph reverts back up to an average output value above 0.9, when the percentage of units changed goes from 80% to 90%, further tests were carried out using a different seed for the random number generator, which determines which units are changed.

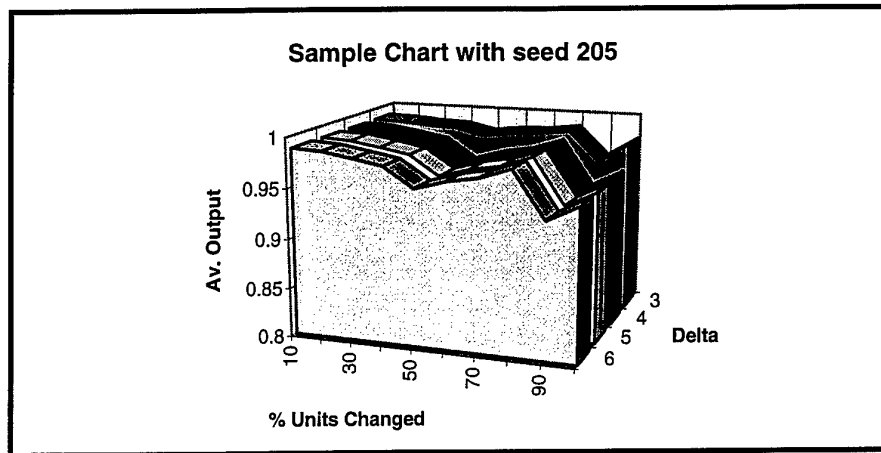

Figure 4. A 3-D Graph to Show Average Desired Output Against Perturbations of Delta Against Percentage of Units Changed Using A Different Seed.

The graph in Fig. 4 shows that the templates generated by using 205 (which itself randomly chosen) as opposed to 1 for the seed in the random number generator, were more easily classified by the neural network since the average output value remained above 0.9 even when the perturbations were of size up to $6 \cdot \delta$. This demonstrates that even though the neural network demonstrated very robust classification properties when classifying perturbed templates, performance on a few templates was slightly degraded due to the particular choice of units being perturbed. This would explain the cause of the valley in Fig. 3, when the percentage of units changed went from 80 to 90% and the classification performance unexpectedly improved.

5. The Missing Data Problem

If an analyst had to wait for all the units in a spatial template to be reported and identified, then it would probably be too late to react to the threat posed by the deployed opposing force. The key to using spatial deployment templates is being able to identify the deployment pattern in a timely fashion, leaving maximum time available to disrupt and counter the opposing forces intentions. It is therefore likely, that in the field, to be of any value to an intelligence analyst, the pattern will

have to be recognised with only partial information about the subordinate units that comprise the full template. Neural networks were chosen for this problem over other pattern recognition techniques or rule based approaches such as [1], due to their known robustness when handling sparse and incomplete datasets.

A sensitivity analysis was performed to ascertain what percentage of units can be omitted from the doctrinal template, and still achieve satisfactory classification properties from a trained neural network. The omitted units were chosen at random using a random number generator.

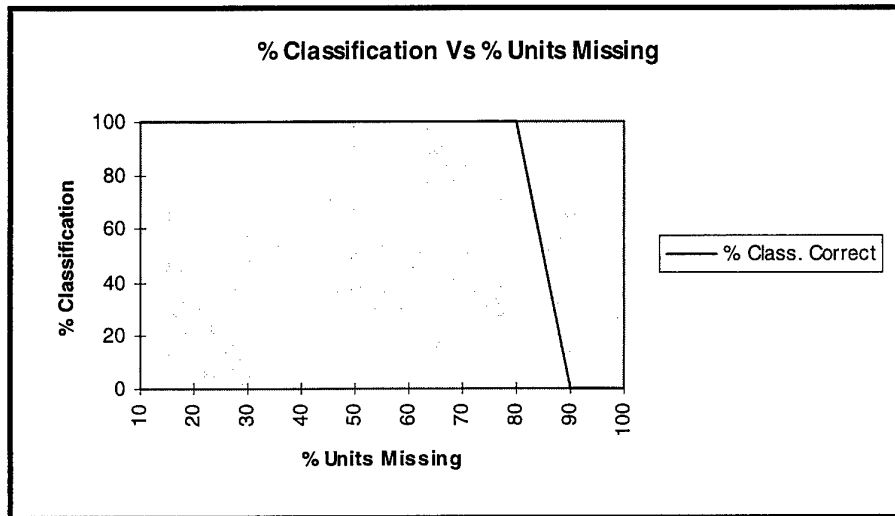

Figure 5. A Graph To Show Percentage Classification Against Percentage Units Missing.

The graph in Fig.5 shows that 100% classification was obtained overall the templates, when up to 80% of the units in each template were omitted. This implies that out of the 22 units in the full template, a deployment pattern can be expected to be correctly classified 100% of the time, when only four of the units are shown to the neural network. It should be noted that out of the 225 example templates presented to the neural network it gave 149 classifications, of which all 149 were correct, giving an overall classification rating of 100%. The policy adopted when plotting the classification graphs throughout this paper, defined percentage classification as the percentage of over all examples presented to the neural network that were classified correctly and not the percentage of correct classifications out of the total number of patterns for which the network offered a classification. Whilst this is probably an overly pessimistic view on classification, it does give a measure on the value of the tool. When deciding on a classification rule to be adopted, the rule has to satisfy an acceptable trade off between the frequency of alerts the system will give to the intelligence analyst, and the typical expected accuracy of each alert. For this particular military intelligence application, it is better to alert more frequently with 80% accuracy than infrequently at 100%. By the time the computer has made a classification, the human analyst would have probably already detected the pattern, or the opposing force may have already carried out the activity that is attempting to be anticipated, rendering little value to the computer's situation assessment.

The results in Fig 5. demonstrate that for this problem, neural networks possess a high degree of robustness, when subjected to incomplete information, which is a common problem when handling intelligence data.

It was suspected that the omission of certain units over other units, may prove significant, for ease of classification by the neural network. To test this suspicion, the units in template no.4 were randomly omitted, over a range of randomisation attempts.

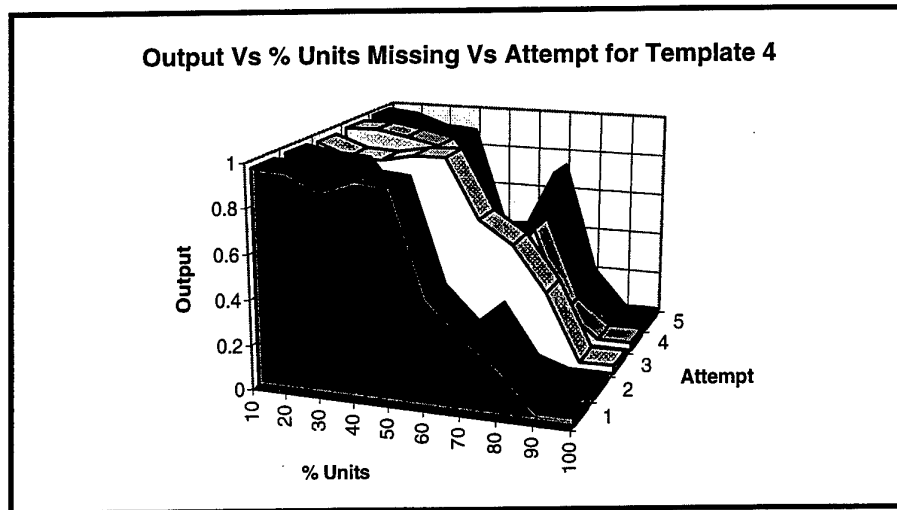

Figure 6. A 3-D Graph Showing the Output Value Against Percentage of Missing Units Against Different Randomisation Attempts For Template No. 4.

Fig. 6 shows similar output value profiles over the range of all five randomisation attempts. All randomisation attempts gave output values above 0.8, for cases where up to 50% of the units were omitted. It can therefore be inferred for the five templates used in this experiment, that the ability of the neural network to classify a template, when individual units are omitted, was not affected by the choice of the individual omitted units.

6. The Rotation Problem

When a spatial template is depicted in doctrinal form (see Fig. 1), for convention, it is always assumed that the unit is deployed in a northerly vertical direction. However in practice, it may well be rotated at any angle, according to the direction of the operation being carried out. This poses a difficult problem for any pattern recognition system, since the tool is expected to be capable of scanning the battlefield, and automatically detecting a deployment template, depicted at any angle offset from the vertical. A simplistic and inefficient approach would be to train the neural network on vertically oriented doctrinal templates. For testing purposes, every combination of subordinate units would then need to be pre-processed into a vertical depiction of the same pattern, before presenting them to the network for classification.

However testing showed that neural networks trained on vertical templates, had a surprising capability to still recognise patterns significantly offset from the vertical. Experiments were carried out by taking a neural network trained on vertical templates, and testing it on versions of the templates rotated in increments of ± 5 degrees. The results presented in Fig. 7 show that as expected, the performance steadily degrades the further the template is rotated from the vertical. However correct classification was still achieved to around ± 60 degrees, before it became unreliable.

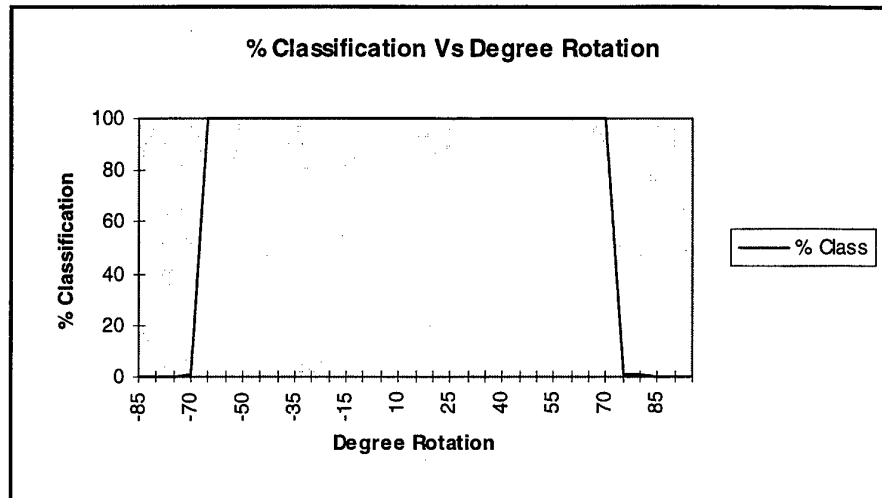

Figure 7. A Graph Showing Percentage Classification Against Angle of Rotation.

The results shown in Fig. 7 demonstrate that neural networks display a surprising degree of robustness, when classifying test patterns that have been significantly rotated, from the patterns that were learnt from the training set. This important property overcame the problem of having to pre-process all templates into a vertical representation before testing. It should be noted that out of the 165 example templates presented to the neural network it gave 130 classifications, of which 125 were correct, giving an overall classification rating of 96%.

Given these results, it was decided to train a neural network with examples of each of the five templates spanning 360 degrees in increments of 30 degrees. Fig. 6 indicates that classification is very reliable beyond 30 degrees, and this may seem a conservative figure, however scope for the missing data and perturbation problems had to be given. If a higher figure than 30 degrees had been chosen, there could have been a penalty to pay when attempting to classify perturbed versions of rotated templates with missing data. To test the network, a validation set was created with the templates rotated in increments of 15 degrees, since this should cause half of the examples to be the most difficult to classify, as every other one will be the maximum distance from a training example. However of course, the other half will be training examples and should always be classified correctly. The graph in Fig.8 shows the percentage classification versus angles of rotation from 0-360 degrees in increments of 15 degrees.

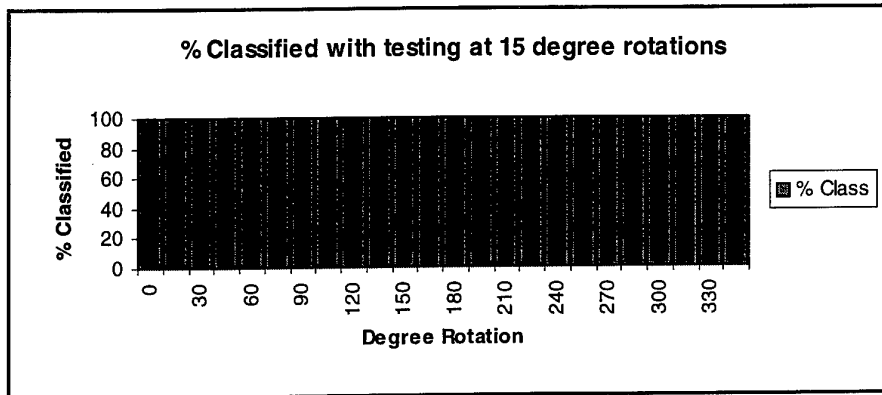

Figure 8. A Graph To Show Percentage Classification Against Angle of Rotation From 0-360 Degrees.

The results shown in Fig. 8 illustrate that training a neural network with each template rotated in increments of 30 degrees, allows combinations of units to be presented to the network regardless of orientation, and be classified 100 % correctly. When considering Fig. 8 it should be pointed out, that there were 120 validation patterns (24 rotations * 5 templates) and the neural net offered a classification 116 times with all 116 being correct, and hence there were only 4 cases for which the network offered no classification (i.e the largest output value was not greater than 0.5 and the difference between the highest and the next highest output node was not less than 0.2) .

7. The Permutation Problem

When using this approach in the field, the question arises about how to handle cases where there are more than one example of a unit in a template, and which sighting goes in which position in the input pattern. The problem would arise if we know a template expects three units of a particular unit type and we have observed one unit of this type in the field. We can not be sure which of the three has been observed, and hence which position in the input string should be filled. One option is to train the network with all the possible permutations of the orderings, however this greatly increased the size of the training set and also gave rise to convergence problems when training the neural networks. However it was realised that given the proven robustness when handling missing units and perturbed templates, it may be possible to overcome the problem when testing with trained networks rather to train networks to overcome the problem. The proposed approach was therefore to test each possible permutation of the observed units and attempt to classify each permutation. The particular permutation with the largest output value is the one the user should believe to be correct.

To test the approach a particular occurrence was chosen, where for each template the three tank battalions were presented to the trained neural network in

all six possible permutations. The graph in Fig. 9 shows the percentage classification over each of the six permutations on each of the five templates.

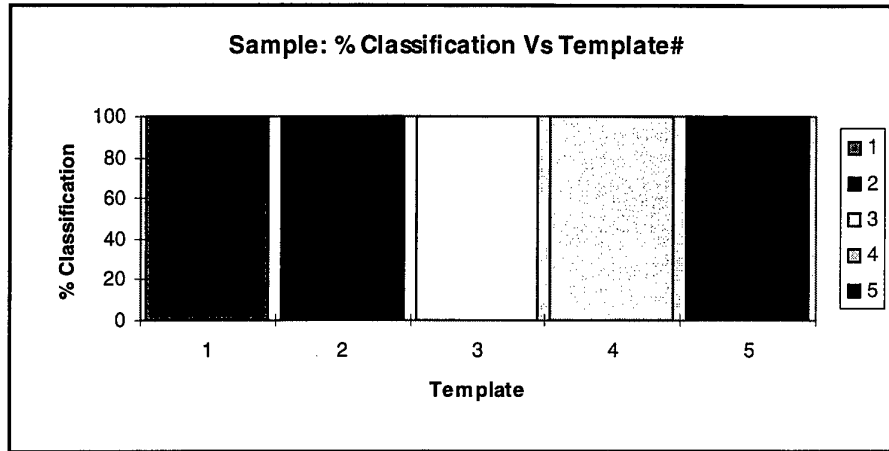

Figure 9. A Graph To Show Percentage Classification Against Permutations.

Since each permutation was classified correctly for each template, it has been shown that this approach solves the ordering problem when dealing with multiple occurrences of units. This result is consistent with the results for missing and perturbed data, and that even with incorrect permutations in the pattern, there is still enough spatial information over the rest of the pattern, for correct classifications to occur.

8. False Alarms

A system may well classify patterns that are present in the data, but if it was to alert the user when there was no pattern present giving rise to a high false alarm rate, it would make the system unreliable from the user's point of view. In order to test the neural network's false alarm rate a test set of 30 totally random patterns was created. The average output value for these patterns was 0.17. However it did offer classifications for 10 of the patterns. Further investigation was carried out to establish how close the random patterns were to any of the templates, therefore establishing whether the network was correct to offer a classification. A measure of match was created in order to compare the random templates against each of the five deployment templates. For each deployment template the sum of the euclidean distances overall units was calculated, for each unit in the random template, from the unit in the deployment template. Therefore, the measure of likeness between two patterns was defined as :

$$M = \sum \text{Sqrt} [(X_i - X_r)^2 + (Y_i - Y_r)^2]$$

where X_i, Y_i are the coordinates of the template units, X_r, Y_r are the coordinates of the random pattern units, the limits of the summation are from 1 to n where n is the number of units in the template.

The 10 patterns that were classified by the network all had high values of M. Although interestingly, other patterns with similar values of M failed to be classified.

9. Scanning The Battlefield

After a number of opposing force units have been sighted on the battlefield, combinations of units will need to be presented to the neural network, to investigate whether the groupings can be classified as a potential deployment template. An exhaustive but inefficient way of doing this would be to split the battlefield up into rectangles equivalent to the size of a template, and test each one against the neural network. However this would be an inefficient approach that would need to be repeated every time a new unit sighting is reported. A more efficient way to perform the task, is to scan the unit database looking for groupings of three or more units within an area the size of a typical template, and then enter that grouping into the neural network. A natural extension to this work is to implement a suitable scanning strategy, which will be reported separately.

10. Results For Examples Containing Combinations of Perturbation, Missing Data and Rotated Templates

Given the successful results reported above on each of the perturbation, missing data and rotation problems, the next step was to test a trained neural network on test data which consisted of combinations of these problems. A network was trained on a training set which included examples of each template rotated in 30 degree increments, to allow the network to recognise any template at any orientation. A validation set was created to test combinations of the three problems, i.e. templates rotated over a range of angles, with a range of units missing and a range of units perturbed. This scenario is what is most likely to occur in the field, and to be of practical benefit to an intelligence officer, the tool must be capable of handling these situations.

The validation dataset was created by randomly selecting a subset of the complete dataset described above, consisting of values of rotation in increments of 45 degrees and randomly omitting units in increments of 20% and then randomly perturbing the remaining units by increments of delta. Increments of 45 degree rotation were chosen, since this should produce templates most difficult to classify, when the network has been trained on examples rotated by 30 degrees. The results presented, are for 43 randomly chosen samples of a particular percentage of missing data, a particular percentage of units perturbed by a certain amount, also rotated by a certain amount. The actual values in each of the 43 randomly chosen samples are given in Appendix 1. For each of the 43 random samples a test set of 75 patterns was generated. This was because for each of the five templates, there are 15 possible permutations of multiple units.

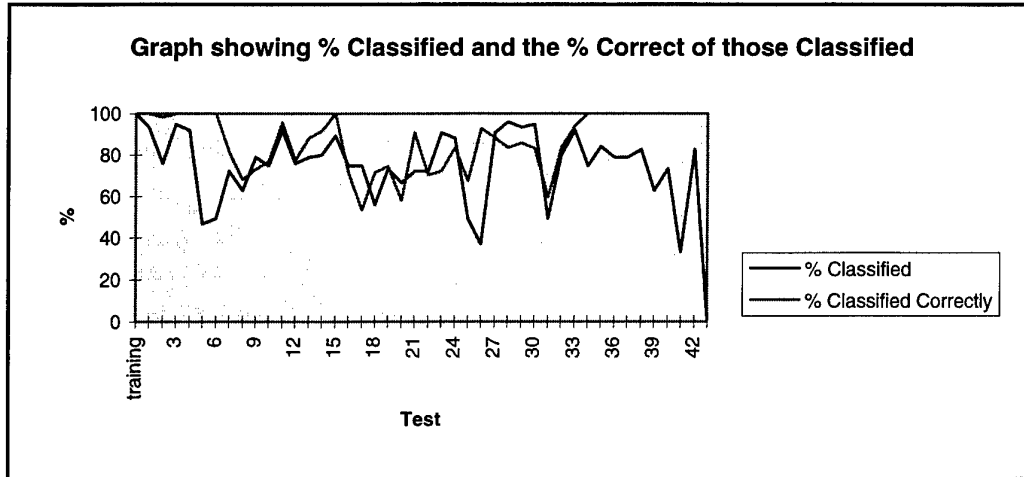

Figure 10. A Graph To Show Percentage Classification for Each of the Samples.

The lowest percentage classified correctly were for cases 17, 20 and 31, although the minimum in all three cases was still above 50%. In these cases the tests all had 40% missing units, 40%+ of their units perturbed, and large deltas. In cases 17 and 31, the decrease in the percentage classified correctly appears to be due mainly to values of delta.

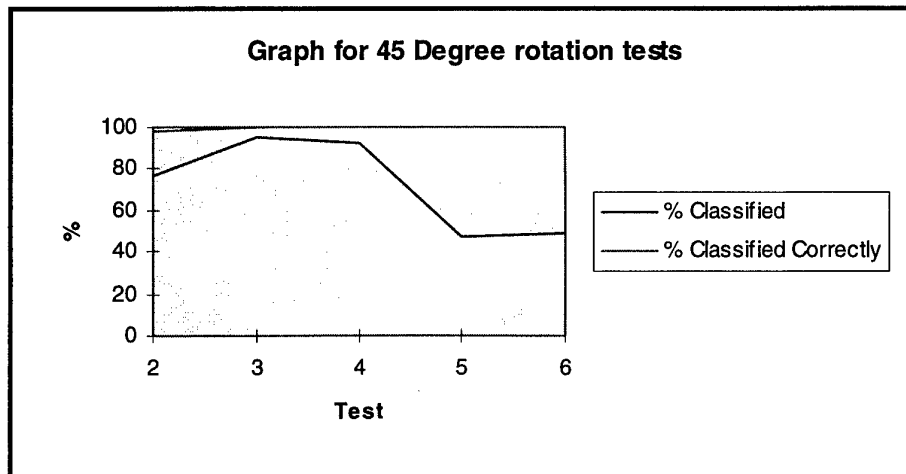

Figure 11. A Graph To Show Percentage Classification For Samples Where Rotation is 45 Degrees.

In Fig.11 there is an observed degradation in the number of classifications offered by the network when the percentage missing is 60 i.e cases 5 and 6, although the percentage classified correctly remains close to 100%.

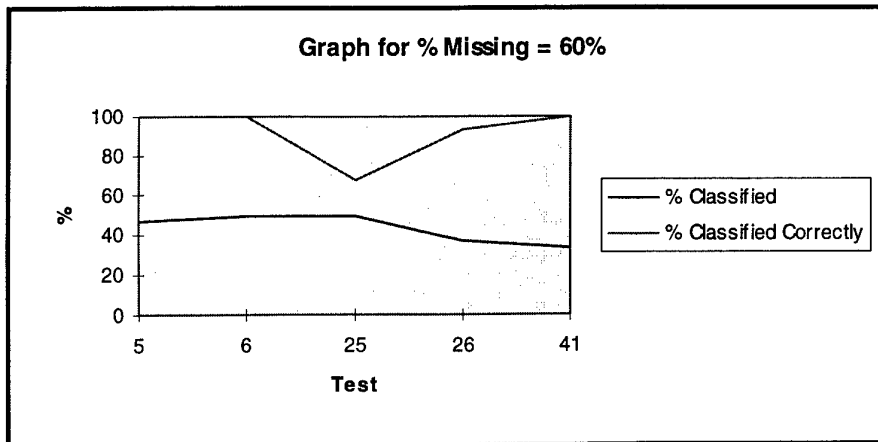

Figure 12. A Graph To Show Percentage Classification For Samples Where Percentage Missing is 60 Degrees.

Fig 12. shows all results for those tests where the percentage missing was 60%. All tests showed worse than average results for percentage classified (i.e only offering classifications for around 50% of all patterns), however as in Fig.11, for those patterns for which classifications were offered, good percentage classification results were produced. Figs 11 and 12 indicate that out of the possible causes for a degrading in performance when all factors are combined, as expected missing units causes the most effect.

The results for combinations of missing data, perturbed data, rotated templates and permutations shown in Figs.10,11 and 12 demonstrate that neural networks are very effective at detecting deployment templates, and even though there is a general degradation in the number of classifications offered by the network when the tool alerts the intelligence analyst, the above results indicate it should prove to be a highly reliable indicator of opposing force intentions .

11. Conclusions

The detection of military deployment templates is an important component of a tactical intelligence analyst's duties. The early detection of a known pattern, could be the difference between victory and defeat, and any computer tool that could accurately detect these patterns would be of great tactical value. In this paper we have reported on the application of neural networks to recognise a range of fictitious but realistic templates. A range of problems such as perturbation, missing data, rotation and permutation have been identified as problems that any proposed tool must be capable of handling. The trained neural network was tested against each problem in turn, to investigate the network's classification performance. The results quoted indicate that this problem is handled well by a neural network approach, and further work is being carried out to explore it's validity in

realistic battlefield scenarios. The spatial template recognition problem is a subset of many spatial pattern recognition problems found throughout defence, and the demonstrated success of this approach, could have important military implications beyond this particular application.

References

1. Mikulin L, Elsaesser D. , "Analysis Tools For Emitter Fix Clustering and Doctrinal Template Matching", Defence Research Establishment Ottawa, Canada, Technical Note 94-11, 1994.
2. Price R, Calder C. , "The Expectation Model and Template Matching For Intelligence Processing", Information Technology Division report, ITD-92-22 ,DSTO, Australia, November 1992.
3. Badiru A., "Expert Systems Applications in Engineering and Manufacturing", Prentice-Hall, 1992.
4. Judd S., " Neural Network Design and the Complexity of Learning", MIT Press, Cambridge MA, 1990.
5. Moller M., "A Scaled Conjugate Gradient Algorithm for Fast Supervised Learning", Computer Science Departmental Report, University of Aarhus, Denmark, 1990.

Appendix A

The test sets used for testing combinations of rotation, perturbation and missing data .

Test	Random	Delta	% Moved	% Missing
1	15 deg	3	40	20
2	45 deg	7	40	20
3	45 deg	3	40	20
4	45 deg	4	20	20
5	45 deg	4	20	60
6	45 deg	1	20	60
7	75 deg	2	20	20
8	90 deg	4	60	20
9	90 deg	4	20	20
10	90 deg	2	60	20
11	105 deg	1	80	20
12	135 deg	3	20	40
13	165 deg	5	80	20
14	165 deg	5	40	20
15	165 deg	2	80	20
16	165 deg	3	40	40
17	180 deg	5	40	40
18	180 deg	3	20	20
19	180 deg	1	40	20
20	195 deg	3	60	40
21	195 deg	3	60	20
22	195 deg	5	20	20
23	195 deg	3	40	20
24	225 deg	5	20	20
25	225 deg	5	20	60
26	255 deg	5	20	60
27	255 deg	5	20	20
28	255 deg	2	40	20
29	255 deg	3	20	20
30	255 deg	3	40	20
31	270 deg	5	40	40
32	270 deg	5	40	20
33	285 deg	2	80	20
34	315 deg	4	40	40
35	315 deg	4	40	20
36	315 deg	2	40	40
37	345 deg	6	20	40
38	345 deg	6	20	20
39	345 deg	2	20	40
40	345 deg	4	20	40
41	345 deg	4	20	60
42	345 deg	4	20	20
43	345 deg	4	20	80

Neural Networks for Automatic Recognition of Military Deployment Templates

Richard Price & Katrina Kerry

(DSTO-RR-0089)

DISTRIBUTION LIST

	Number of Copies
DEFENCE ORGANISATION	
Task sponsor:	
SO1 Intelligence Development, DMI, LHQ	1
S&T Program	
Chief Defence Scientist)	
FAS Science Policy)	1 shared copy
AS Science Industry External Relations)	
AS Science Corporate Management)	
Counsellor, Defence Science, London	Doc Control sheet
Counsellor, Defence Science, Washington	1
Senior Defence Scientific Adviser)	1 shared copy
Scientific Adviser - Policy and Command)	
Assistant Secretary Scientific and Technical Analysis	1
Navy Scientific Adviser	3 copies of Doc Control sheet and 1 distribution list
Scientific Adviser - Army	Doc Control sheet and 1 distribution list
Air Force Scientific Adviser	1
Director Trials	1
Director, Aeronautical & Maritime Research Laboratory	1
Electronics and Surveillance Research Laboratory	
Director Electronics and Surveillance Research Laboratory	1
Chief Information Technology Division	1
Research Leader Command & Control and Intelligence Systems	1
Research Leader Military Computing Systems	1
Research Leader Command, Control and Communications	1
Executive Officer, Information Technology Division	Doc Control sheet
Head, Information Architectures Group	1
Head, C3I Systems Engineering Group	Doc Control sheet
Head, Information Warfare Studies Group	Doc Control sheet
Head, Software Engineering Group	Doc Control sheet
Head, Trusted Computer Systems Group	Doc Control sheet
Head, Advanced Computer Capabilities Group	Doc Control sheet
Head, Systems Simulation and Assessment Group	Doc Control sheet
Head, Intelligence Systems Group	Doc Control sheet
Head Command Support Systems Group	1
Head, C3I Operational Analysis Group	Doc Control sheet
Head, Human Systems Integration Group	Doc Control sheet

Head, Information Management and Fusion Group	1
Richard Price (Author)	1
Katrina Kerry (Author)	1
Publications and Publicity Officer, ITD	1
DSTO Library	
Library Fishermens Bend	1
Library Maribyrnong	1
Library DSTOS	2
Library, MOD, Pyrmont	Doc Control sheet
Forces Executive	
Director General Force Development (Joint),	1
Director General Force Development (Sea),	1
Director General Force Development (Land),	1
Director General Force Development (Air),	1
Director Operational Information Systems	1
DD-EW	1
Army	
ABCA Office, G-1-34, Russell Offices, Canberra	4
Project Director, AUSTACSS	1
CO RISTA Regiment	1
RPLO ICSS - AUSTACSS User Facility	1
Air Force	
CO Electronic Warfare SQN	1
S&I Program	
Defence Intelligence Organisation	1
Library, Defence Signals Directorate	Doc Control sheet
Acquisition and Logistics Program	
Director General, Information Management	1
Project Director, ADFDIS	1
Project Director, JP2030	1
B&M Program (libraries)	
OIC TRS, Defence Central Library	1
Officer in Charge, Document Exchange Centre (DEC),	1
US Defence Technical Information Center,	2
UK Defence Research Information Centre,	2
Canada Defence Scientific Information Service,	1
NZ Defence Information Centre,	1
National Library of Australia,	1
Universities and Colleges	
Australian Defence Force Academy	1
Library	1
Head of Aerospace and Mechanical Engineering	1
Senior Librarian, Hargrave Library, Monash University	1
Librarian, Flinders University	1

Other Organisations

NASA (Canberra)	1
AGPS	1
State Library of South Australia	1
Parliamentary Library, South Australia	1

OUTSIDE AUSTRALIA**Abstracting and Information Organisations**

INSPEC: Acquisitions Section Institution of Electrical Engineers	1
Library, Chemical Abstracts Reference Service	1
Engineering Societies Library, US	1
American Society for Metals	1
Documents Librarian, The Center for Research Libraries, US	1

Information Exchange Agreement Partners

Acquisitions Unit, Science Reference and Information Service, UK	1
Library - Exchange Desk, National Institute of Standards and Technology, US	1

SPARES 10

Total number of copies: 77

DEFENCE SCIENCE AND TECHNOLOGY ORGANISATION DOCUMENT CONTROL DATA				1. PRIVACY MARKING/CAVEAT (OF DOCUMENT) N/A	
2. TITLE Neural Networks for Automatic Recognition of Military Deployment Templates			3. SECURITY CLASSIFICATION (FOR UNCLASSIFIED REPORTS THAT ARE LIMITED RELEASE USE (L) NEXT TO DOCUMENT CLASSIFICATION) Document (U) Title (U) Abstract (U)		
4. AUTHOR(S) Richard Price and Katrina Kerry			5. CORPORATE AUTHOR Electronics and Surveillance Research Laboratory PO Box 1500 Salisbury SA 5108		
6a. DSTO NUMBER DSTO-RR-0089		6b. AR NUMBER AR-009-783		6c. TYPE OF REPORT Research Report	7. DOCUMENT DATE August 1996
8. FILE NUMBER N9505/10/110	9. TASK NUMBER ADL 93/134	10. TASK SPONSOR DGFD(L)	11. NO. OF PAGES 28		12. NO. OF REFERENCES 5
13. DOWNGRADING/DELIMITING INSTRUCTIONS N/A			14. RELEASE AUTHORITY Chief, Information Technology Division		
15. SECONDARY RELEASE STATEMENT OF THIS DOCUMENT Public Release OVERSEAS ENQUIRIES OUTSIDE STATED LIMITATIONS SHOULD BE REFERRED THROUGH DOCUMENT EXCHANGE CENTRE, DIS NETWORK OFFICE, DEPT OF DEFENCE, CAMPBELL PARK OFFICES, CANBERRA ACT 2600					
16. DELIBERATE ANNOUNCEMENT No limitation					
17. CASUAL ANNOUNCEMENT Yes					
18. DEFTEST DESCRIPTORS Neural networks Tactical intelligence Military deployment Pattern recognition Spatial data					
19. ABSTRACT A key function in tactical intelligence, is the ability to recognise patterns of behaviour in opposing force activities. Deployment templates are patterns that define the spatial layout opposing force units are known to employ, when carrying out a range of different operations. The early detection of these patterns, provide key indicators to intelligence analysts, for predicting future opposing force activities. In this paper, we investigate the use of neural networks to automatically detect deployment templates, when given full or partial opposing unit positional information. The spatial template recognition problem is a subset of many spatial pattern recognition problems found throughout defence, and the demonstrated success of this approach, could have important military implications beyond this particular application.					