

SEP 30 1960

RESULTS OF 1959 NUCLEAR POWER PLANT CONTAINMENT TESTS

by Alf Kolflat
Sargent & Lundy



DISTRIBUTION STATEMENT A

Approved for public release
Distribution Unlimited

927675

PREPRINT
PAPER NO. 10

NUCLEAR ENGINEERING
& SCIENCE CONFERENCE

April 4-7, 1960, New York Coliseum
New York, New York

Publication rights are reserved by the
Nuclear Congress. Opinions expressed
are not necessarily those of Engineers
Joint Council, or any of the participating
Societies.

N-87675

LIBRARY COPY

MAY 16 1960

~~██████████~~ NASA

DTIC QUALITY INSURANCE

published by
ENGINEERS JOINT COUNCIL
29 West 39th Street
New York 18, New York

19961217 127

06

X

RESULTS OF 1959
NUCLEAR POWER PLANT CONTAINMENT TESTS

By

Alf Kolflrat
Sargent & Lundy

Introduction

The nuclear power plants which are being designed to operate on the pressurized or boiling water cycle all use some type of containment shell. This containment is designed to prevent escape of fission products which would be released by an accidental rupture of the reactor vessel or other pressurized equipment. Such a break in the pressure system would result in release of steam and boiling water, possibly carrying with it fission products.

The containment shells surrounding the reactors have been designed so that all of the boiling water could flash into lower pressure steam without exceeding the pressure for which the containment shell is designed.

The main purpose of the tests which will be described in this paper is to demonstrate that the size of containment shells can be very materially reduced.

Some tests with a small containment tank were conducted in 1956 and 1957. The results were reported at the American Power Conference in Chicago in March 1957 and are printed in their proceedings. As an illustration of these early tests, a total quantity of 266 lbs. of boiling water at 1000 psig was suddenly released in the test tank. The resultant theoretically calculated pressure was 50 psig. With bare steel walls, the actual pressure in the tank was 24 psig and with concrete covered walls 38 psig. However, when cold water was arranged in the proper location in the tank, no pressure rise was observed.

These tests convinced us that there was a possibility of drastic reduction in size of containment shells and corresponding reduction in cost.

Many different arrangements were considered for continuation of the tests, but the cost and difficulty in finding a good location and more pressing work delayed the new test program. In the fall of 1958, we obtained permission to conduct further tests at the Hennepin Power Plant of Illinois Power Company. The plant construction going on there greatly facilitated the erection of the test equipment.

I. Description Of Test Apparatus And Instrumentation

The test equipment consisted basically of a vertical containment shell, 14 feet in diameter and 32 feet high, designed for a pressure of 100 psig. This shell was installed underground approximately 1200 feet away from the power plant for safety reasons. A drum, 42 inches in diameter and 23 feet long, designed for a pressure of 700 psig, was placed inside the containment shell. This drum had a number of 12 inch openings along its vertical side as well as one at the bottom. The test procedure was to fill the drum with varying amounts of water which was heated to a boiling pressure of approximately 600 psig by steam from the power plant. The 12 inch openings on the drum were closed by blind flanges, except for one opening in each test which was covered by an explosion diaphragm designed so that it would break at approximately 600 psig. In order to control the time when the break occurred, a steam operated triggering device was installed to puncture the diaphragm and thus initiate its breakage. Instrumentation representing 14 different readings of pressures, temperatures, etc., both for the containment shell and the drum was installed in an adjoining instrument house. Due to the rapidity of the action, the instrument panel was photographed with a movie camera so that approximately 16 readings per second

were obtained. In addition to the standard type gauges, a Brush two pen recorder was used to record pressure changes within one-hundredth of a second in the drum and in the top of the containment vessel. The standard instruments used showed good agreement with the high speed instrument. The following readings were taken:

1. Pressure in vapor space of drum. (Standard and Brush Instruments)
2. Pressure in water space of drum.
3. Pressure at top of containment vessel. (Standard and Brush Instruments)
4. Pressure at bottom of containment vessel.
5. Temperature of water in drum.
6. Temperature at top of containment vessel.
7. Temperature at the bottom of containment vessel.
8. Water level in the drum.

In addition, steam and water flow meters as well as gauges for steam and water supply, etc., were also used.

The accompanying photographs and Figure 1 illustrate the test arrangement. Figure 1 shows a cross section of the containment shell and the steam pressure drum which simulates the reactor. When side outlet openings were used for tests, they were connected to a 90° elbow facing down toward the cold water located in the bottom of the containment shell. This elbow is shown at the top side outlet opening in Figure 1. Figure 2 shows the details of the explosion diaphragm arrangement without the triggering device.

Before the tests were conducted, calculations were made of the expected pressure which would result in the containment vessel upon the release of varying amounts of boiling water from the drum, assuming no cooling. Figure 3 is a plot of

these calculations and shows that the release of 8000 lbs. of boiling water--the maximum capacity of the drum--would give an expected pressure of 153 psig.

Figure 4 shows the relationship between boiling water and cold water at 70° in order to obtain a mixture of 200°F and 250°F. With a discharge of 8000 lbs. of boiling water, 18,500 lbs. of 70°F water would be required in order to obtain a mixture temperature of 200°F without other cooling. Based on these estimates, it was assumed that approximately 17,000 lbs. of cold water would be adequate for the maximum discharge of 8000 lbs. of boiling water.

When the tests were planned, provisions were made for installing a number of water trays at different levels in the containment tank. These trays were hinged in such a manner that they were expected to tip due to the build-up of pressure which was expected in the bottom of the containment shell. Tests indicated, however, that the water did not spill out of these trays as expected and very little cooling effect was obtained since the surface was insufficient to effect noticeable cooling.

II. Test Procedure

The first test was made with 3000 lbs. of boiling water and 7000 lbs. of cold water and by puncturing the diaphragm covering the bottom outlet. The distance between the diaphragm and the cold water level was 1-1/2 feet. The theoretically expected containment pressure without cold water was 74 psig, while the actual obtained pressure was in the order of 4 psig. It should be mentioned that the scale of the pressure reading instruments is such that it is difficult to ascertain the exact pressure within a limit of 2 to 3 psig. Even though no substantial containment pressure was obtained during this test, inspection indicated that there had been a severe turbulence in the bottom of the tank as grating and

certain piping had been torn loose and had to be fixed. The complete discharge occurred in 2-1/2 seconds. Figure 5 is a graph showing the results of the first test.

The next test was conducted with 8000 lbs. of boiling water and 17,000 lbs. of cold water. Figure 6 shows the results of this test. The actual maximum containment pressure was 5 psig while without cold water the theoretically calculated pressure is 153 psig. The discharge of 8000 lbs. of boiling water took 5-1/2 seconds.

Test No. 3 was conducted without any material quantity of water in the bottom of the containment shell, but 10,500 lbs. of water distributed in a number of trays. In this test, the pressure rose to 77 psig, as compared to a theoretically expected pressure of 110 psig. A small quantity of cold water was in the bottom of the containment vessel during this test, but the cold water in the trays did not contribute to the pressure reduction as none of the trays tipped and spilled water as expected.

Test No. 4 was conducted with 8000 lbs. of boiling water, but with reduced amount of cold water, i. e. 10,000 lbs., in the bottom of the containment vessel. This gave a maximum pressure of 44 psi showing an increase of 39 psi, compared to Test No. 2 which had 17,000 lbs. of cold water.

During Tests Nos. 5 and 6, there was some steam leakage and complete breakage of the diaphragm did not occur so that these tests rendered no significant data.

In order to obtain a picture as to what would happen in case steam was ejected instead of water, Test No. 7 was run with the explosion diaphragm placed on a 90° elbow connected to the top side outlet. Due to the uncertainty as to the results

of the mixing action with steam, only 6400 lbs. of boiling water was placed in the drum. This assured that the drum water level was below the nozzle opening. There would therefore be no discharge of water except as entrained with the steam. 17,000 lbs. of cold water was placed in the bottom of the vessel. In this case, a maximum pressure of 44 psig occurred in the containment vessel as compared to the 125 psig theoretical pressure without cooling. This test demonstrated that, in spite of the distance of approximately 22 feet from the discharge elbow to the water level, a radical pressure reduction took place and a good part of the high pressure steam was condensed without creating a high pressure rise. Wide containment pressure pulsations, however, did take place during this test.

Test No. 8, conducted with 6000 lbs. of boiling water in the drum, also represents ejection of steam only as the drum water level was below the discharge elbow connection. During this and the next test, the elbow was connected to the middle side outlet opening, resulting in a distance of approximately 17 feet between the diaphragm and the cold water level. Test No. 8 also showed pressure pulsation in the containment vessel but to a lesser degree than in Test No. 7. Unfortunately, leakage in trigger steam line increased the containment pressure to 20 psig and resulted in a corresponding temperature rise before the diaphragm broke so that the maximum pressure was higher than would have been otherwise obtained.

Test No. 9 was conducted with a higher water level in the drum so that the original outflow consisted of boiling water before the level decreased sufficiently to emit steam. The reduction in pulsation, as well as pressure rise, was noticeable.

Figure 7 illustrates the effectiveness of the pressure reduction in relation to the distance between the ejection opening and the absorbing cold water level. It must be emphasized that for the upper openings, the reduction in pressure increase is not entirely a function of the distance to the cold water, but is also influenced by

the fact that steam is ejected instead of water. Steam will apparently expand into the surrounding space somewhat faster than pressurized water. This curve is not an exact representation due to the limited number of observations but shows clearly the general effect.

Test No. 10 was conducted with 8000 lbs. of boiling water and 17,000 lbs. of cold water with the explosion diaphragm in the lower side opening. The results of this test were not significant because of a 3 second delay between the puncture of the diaphragm and its final rupture.

In order to obtain a calibration of what would happen without cold water in the containment vessel, Test No. 11 was run with a boiling water quantity of 4800 lbs. which theoretically should give a containment pressure of 107 psi. This represented the maximum quantity which seemed permissible without exceeding the containment design pressure. During this test, the pressure in the containment vessel rose to 93 psig. The difference between this and the theoretically expected pressure rise is due to the cooling effect of the walls of the containment vessel, etc. The results of this test are shown in Figure 8.

In all of these tests, the discharge time was longer and the velocity of the discharged water and steam was less than expected even though, in most cases, the diaphragm broke so completely that there was no restriction to the flow. It was therefore decided to try to break two diaphragms at the same time in order to obtain a faster outflow. Three such tests, Nos. 12, 13 and 14, were run without success as only one of the diaphragms broke in spite of the fact that both triggering devices punctured the diaphragms. Apparently the immediate drum pressure drop which occurred when one diaphragm broke was sufficient to prevent the other diaphragm from breaking even though it was punctured. During these tests, the diaphragms were placed on the bottom outlet opening and on the bottom side outlet opening

with the elbow directed down. It may be of interest to note that in all three of these tests the side outlet diaphragm broke but not the one at the bottom.

Finally, in the fourth such test, Test No. 15, using somewhat weaker diaphragms, we were successful in completely breaking the two diaphragms simultaneously. In this test 15,500 lbs. of cold water was kept in the bottom of the containment vessel. Much to our surprise the discharge time for 8000 lbs. of boiling water was not reduced from that obtained in Test No. 2 with one diaphragm, but the pressure in the drum dropped much faster, which will be illustrated later. All of these tests, when the boiling water was discharged from the bottom opening of the drum, showed conclusively that no appreciable pressure rise occurred if boiling water was ejected from the drum into cold water.

III. Discharge Time

One of the experiences gained during these tests was that the quantity of water discharged per second through a 12 inch opening was considerably less than expected. The drop in drum pressure after the break was recorded both on a Brush recorder and on ordinary gauges which gave a good agreement. The water level indicator showing the outflow of the water checked fairly well with the pressure reduction. Figure 9 shows the pressure drop in the drum in relation to time after breakage. It will be noted that on Test No. 7, where steam was ejected, that there were rapid pulsations as the drum pressure dropped suddenly from 500 psig to 320 psig within a fraction of a second, but then the pressure rose rapidly to about 440 psig and gradually fell off. This figure also demonstrates the rapid pressure drop which occurs in the drum in Test No. 15, when two diaphragms were broken, as compared to the Test No. 2 where only one diaphragm was broken even though the boiling water quantity in the drum was the same. Table I summarizes the test results shown on this curve.

IV. Containment Pressure Conditions

The main purpose of these tests was to determine an efficient way of reducing containment vessel pressure and also to determine the difference between steam and water ejection. Figure 10 shows the pressure rise which occurred in the containment vessel in the first 15 seconds after breakage. Tests Nos. 1, 2 and 15 show a very small pressure rise as the cold water absorbed all the heat. The pressure curves for these three tests represent the pressure in the top of the containment vessel, while no pressure rise was noticeable on the gauge at the bottom.

Test No. 3 which had little effective cooling except from the shell surface and Test No. 4 which had insufficient cold water show higher containment pressure rise. There was an appreciable difference in pressure readings at the bottom and top of the containment vessel for these tests. We are not able to find an explanation for this difference in pressure reading as there was no restriction in the containment vessel which would explain this difference and, at the beginning and end of each test, the two locations showed the same pressure. During Test No. 3, leakage occurred which explains why the pressure rose before the diaphragm broke and this heated the air in the containment vessel and resulted in a higher final pressure than would have been obtained otherwise. All of the tests shown in Figure 10 deal with water ejection from the bottom opening and it will be seen that there is hardly any pulsation in the containment pressure, except for Test No. 11, in which case there was no cooling water in the containment shell. This illustrates that even a boiling water ejection will result in pressure pulsation if there is no cold water present.

An illustration of containment pressure with ejection of steam or steam-water mixture is shown in Figure 11. Test No. 7 represents steam ejection from the

top side outlet and it shows violent pressure fluctuations. Test No. 8, where drum water level was also below the outlet so that steam was ejected, showed much more pulsation and, in this case, the temperature and pressure in the containment vessel had been increased considerably before breakage due to leakage of some of the steam pipes. Test No. 9, which represents ejection from the middle side opening where water was discharged first and later some steam, indicated very little pressure fluctuation. Finally, Test No. 10 showed that there is no pulsation and good pressure reduction with water ejection from the bottom side outlet with a distance of approximately 6 feet between outlet opening and cold water level. Table II shows the maximum pressure reached inside the containment vessel during the various tests.

V. Test with Water Jacket

The tests which have thus far been described showed that if proper mixing of the escaping hot water or steam with the cold water was obtained, appreciable reduction would occur in the expected containment pressure, and these tests concluded the first part of the test program.

In an endeavor to find a simple, universal, solution to the mixing problem, a special test arrangement was prepared. The pressure drum was cut in three parts. The cylindrical mid-section with the side outlet nozzles was removed and replaced with a thin wall cylindrical section made of 3/8 inch plate, approximately 16 feet long, so that the overall length of the new drum assembly was again 23 feet. The top and bottom were the original heavy section parts. In the 3/8 inch plate section, a 10 foot longitudinal, half round groove 1/8 inch deep was machined so that the plate thickness in the bottom of the groove was only 1/4 inch. Plate samples were tested for tensile strength and it was determined that the grooved plate should rip when the internal pressure was 650 to 700 psig. Outside

of this new pressure drum was placed a water jacket with an inside diameter 4 inches bigger than the outside of the drum, thus providing an annular space of 2 inches between the 3/8 inch thick pressure vessel and the inner part of the water jacket. This inner part of the water jacket was made of thin steel plate 1/32 inch thick. The outer cylindrical part of the water jacket had a diameter of 7 feet and was made of 1/8 inch plate, so that there was approximately a 3-1/2 foot space between the outer water jacket and the containment vessel wall. The jacket contained approximately 25,000 lbs. of cold water, which had a temperature of 80°F at the test moment. Figure 12 shows the test arrangement. Detail B shows connection between the thin and heavy section, and Detail C shows the shape of the groove.

The test plan was to gradually increase the boiling water pressure in the tank to approximately 550 psig and then suddenly increase the pressure by admitting high pressure steam into the top of the drum above the water level and thus quickly increase the drum pressure till the drum failed completely, expecting that the cold water in the jacket would reduce the pressure in the containment shell. The pressure drum was slowly brought up to a pressure of 550 psig and after all readings had been checked, the steam valve was opened. This required approximately eight seconds and within an additional seven seconds the pressure in the drum had increased to 670 psig at which time the drum failed completely. When the pressure drum broke, a violent water surge hit the side of the containment vessel and broke the containment vessel plate halfway down in the ground. The subsequent ripping or tearing action tore the containment vessel completely in two and raised the top part slowly out of the ground. Analyses are being made of the shell material to try to determine the character of the break.

The pressure recording instruments were functioning for a period of one and one-half seconds after the break of the high pressure drum and at this time, the steam line that was attached to the moving, displaced shell part upset the instrument house and stopped all recording. Figure 13 shows an enlarged picture of the Brush pressure recorder tape for this period. It is apparent from this tape, as well as from other pressure instruments, that the containment vessel pressure did not exceed 30 psig. This indicates that the breakage of the containment shell was due to water impact rather than pressure in the shell.

An analysis of the pressure recording indicates that the shell pressure rose to approximately 30 psig in a period of one to two tenths of a second, dropped and then in a period of one half second surged back to about 20 psig and stayed at that level for another half second after which all recording stopped. The negative pressure recording following the first pressure surge is due to instrument swing and does not represent actual pressure conditions.

The Brush pressure reading for the drum dropped from 650 psig to zero in three tenths of a second and then showed a great negative instrument swing and then surged up to 760 psig, even though other readings showed a low pressure in the containment at that time. The only explanation we can give to this upsurge and continuation of the pressure recording for the drum is that the instrument pipe which was water filled was pinched off by bending and that this pinching created a permanent water pressure inside the pipe. The reading had no connection with the drum pressure prevailing in the drum as the drum was destroyed at this time.

Even though the results of this test were very discouraging insofar as the integrity of the containment vessel was concerned, it again demonstrated that cold water in the containment would greatly reduce the pressure, even when action is as close to instantaneous as in this case.

The test equipment was damaged to such an extent that it was not practical to contemplate a future test.

VI. Acknowledgements

The following companies donated material and services to make these tests possible:

Black, Sivalls and Bryson, Inc.
Commonwealth Edison Company
Cunningham Brothers, Inc.
Henry Pratt Company
Illinois Power Company
Midwest Piping Company, Inc.
Republic Flow Meters Company
Sargent & Lundy
Sprinkmann Sons Corporation

TABLE I
DISCHARGE TIME FOR WATER OR STEAM
FROM PRESSURE DRUM THROUGH 12 INCH OPENING

Initial Drum Pressure for All Tests 580-600 Psig
Except Test No. 7 - 500 Psig

Test No.	Boiling Water in Drum Lbs.	Time for Complete Discharge from Drum Sec.	Time for 50% Press. Reduction in Drum Sec.	Time for 75% Press. Reduction in Drum Sec.	Average Flow Through 12 Inch Opening Lbs/Sec.	Location of Outlet	
1	3,000	2.5	1.5	1.7	1,200	bottom	
2	8,000	5.5	4.0	4.7	1,450	bottom	
3	5,000	4.5	2.7	3.2	1,100	bottom	
4	8,000	6.1	4.8	5.7	1,300	bottom	
11	4,800	3.8	2.5	3.0	1,260	bottom	
15	8,000	6.2	4.0	5.6	1,290	bottom and bottom side	
10	8,000	Approx. 10.0	6.0	8.2	800*	bottom side elbow	3 sec. lag between puncture and break of diaphragm
8	6,000	8.0	4.0	5.5	750*	middle side elbow	
9	7,500	9.0	5.0	6.5	830*	middle side elbow	
7	6,400	9.0	4.5	5.8	710*	top side elbow	

*Based on all boiling water originally in drum divided by discharge period even though actual flow is restricted to steam formed.

TABLE II
 MAXIMUM PRESSURE IN CONTAINMENT VESSEL
 FOR DIFFERENT TESTS

Test No.	Boiling Water in Drum Lbs.	Cold Water in Bottom of Containment Lbs.	Location of Diaphragm	Maximum Pressure in Shell Psig	Theoretical Pressure in Shell Psig	
1	3,000	7,000	bottom	4	74	
2	8,000	17,000	bottom	6	153	
15	8,000	15,500	bottom and bottom side	5	153	
3	5,000	0*	bottom	77	110	
11	4,800	0	bottom	93	107	Pulsation when no water in containment
4	8,000	10,000**	bottom	44	153	
7	6,400	17,000	top side	44	125	Pulsation due to steam discharge
8	6,000	17,000	middle side	38	126	Higher containment pressure due to pipe leakage before test
9	7,500	25,000	middle side	19	147	Pulsation reduced some water discharge
10	8,000	17,000	bottom side	12	153	No pulsation

FIGURE 10

FIGURE 11

*Some cold water in trays above diaphragm but this water resulted in no appreciable pressure reduction. Also leakage in steam pipe caused pressure rise before breaking of diaphragm.

**Insufficient cooling water, compare with Tests Nos. 2 and 15.

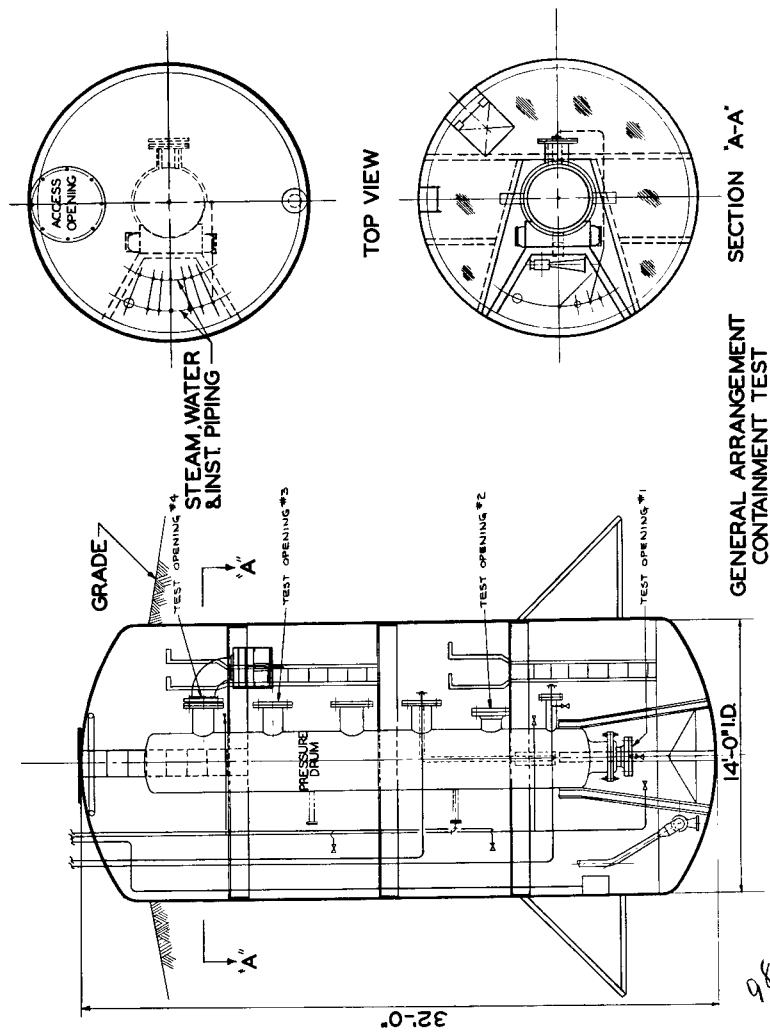

98.

FIGURE NO. 1 - Results of 1959 Nuclear Power Plant Containment Tests

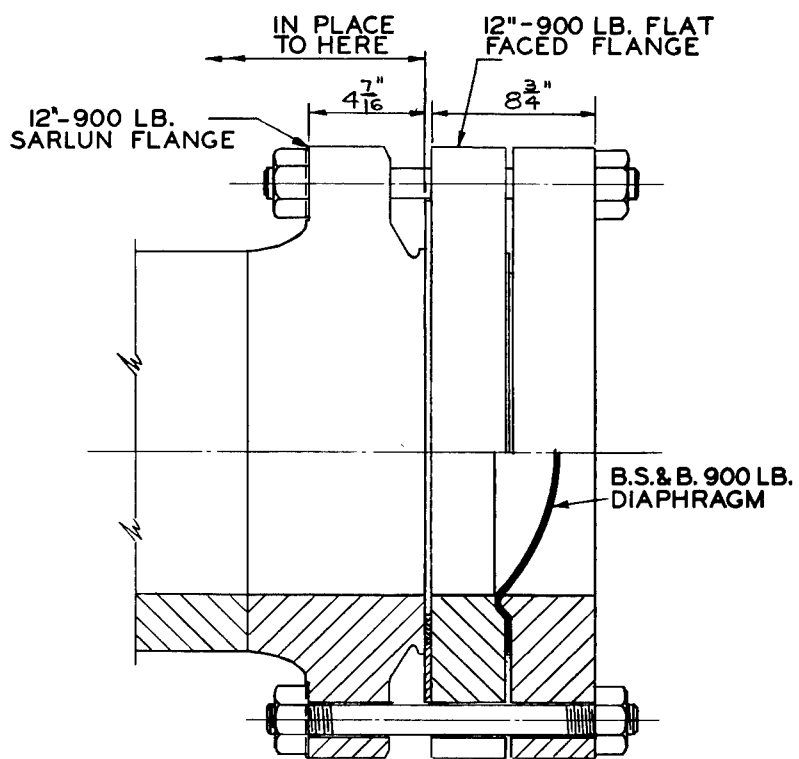

DIAPHRAGM ASSEMBLY

FIGURE NO. 2

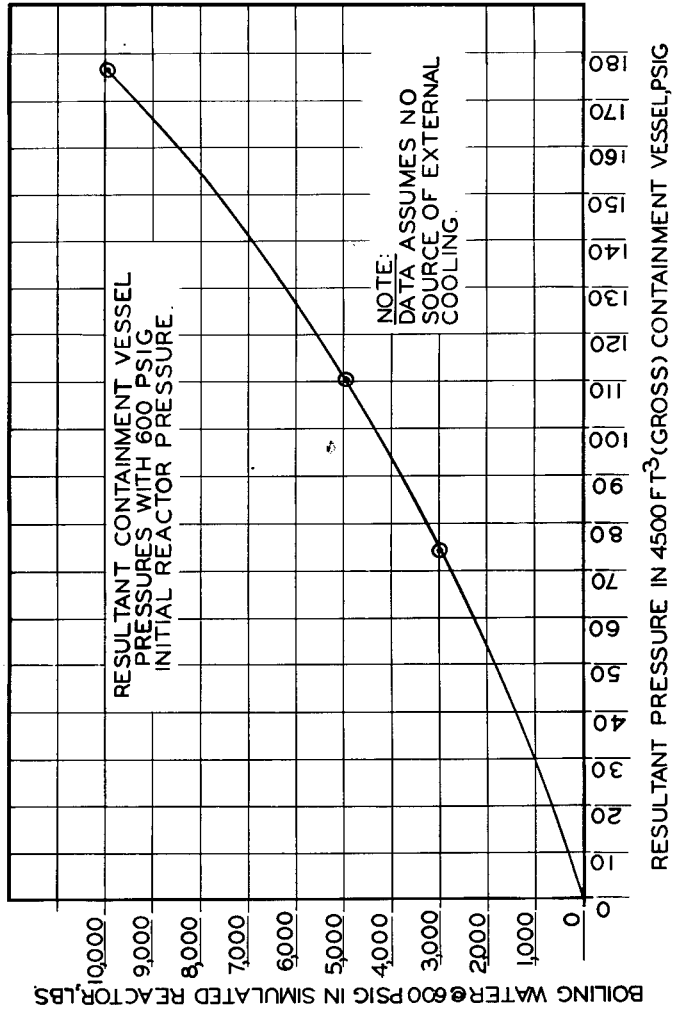
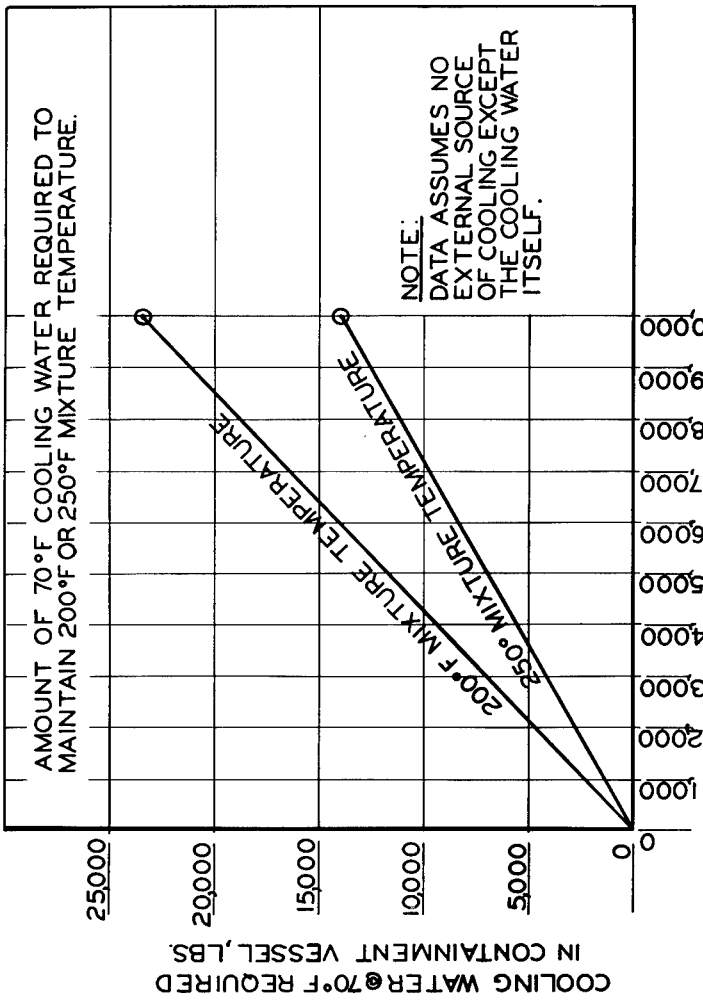
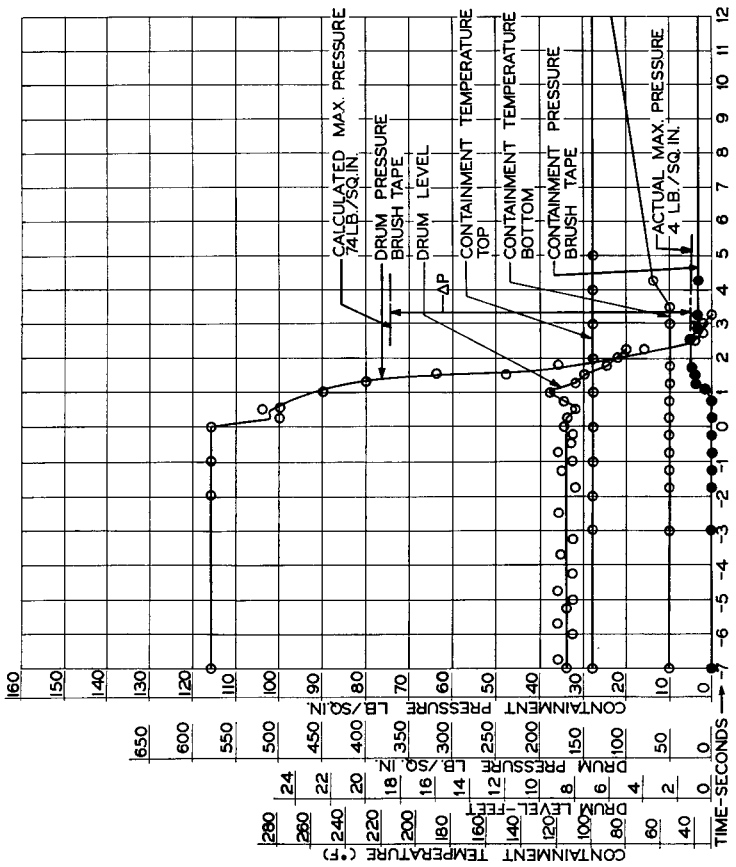

FIGURE NO. 3



BOILING WATER @ 600 PSIG IN SIMULATED REACTOR, LBS

FIGURE NO. 4



3000 LB BOILING WATER
 7000 LB COLD WATER IN CONTAINMENT VESSEL BOTTOM
 TEST NO.1 JUNE 19, 1959

FIGURE NO. 5

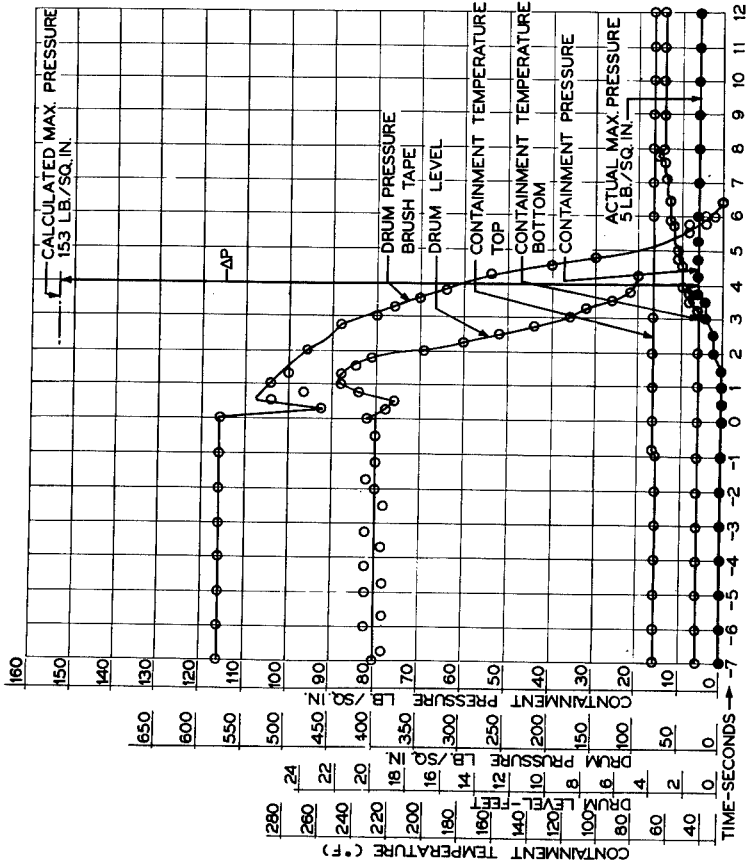

8000 LB. BOILING WATER
 17000 LB. COLD WATER IN CONTAINMENT VESSEL BOTTOM

TEST NO 2 JUNE 19, 1959

FIGURE NO. 6

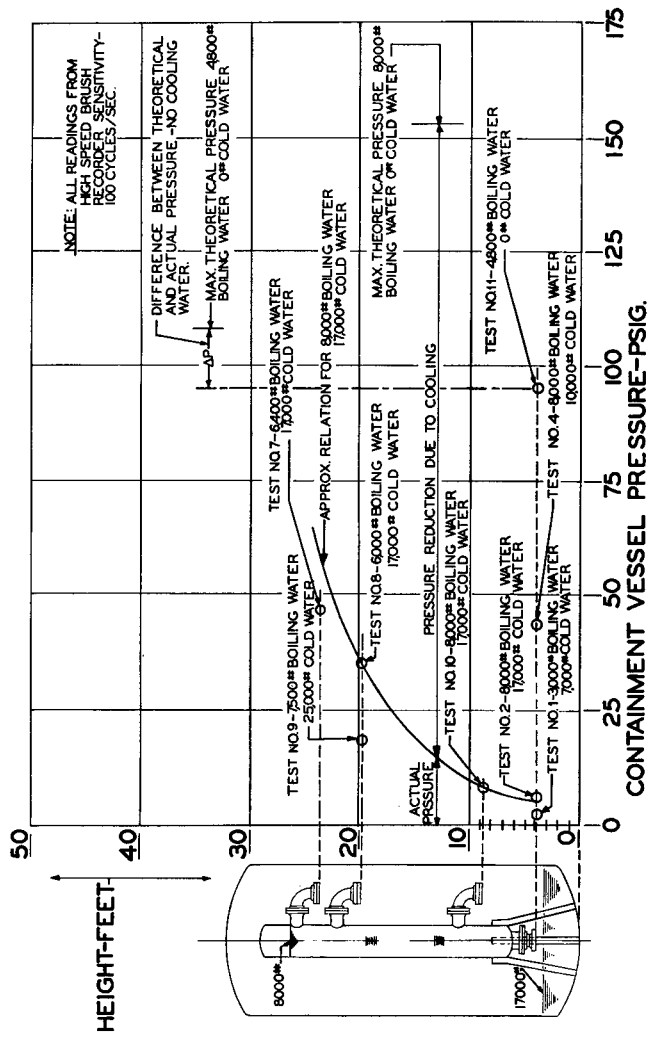

CONTAINMENT VESSEL PRESSURE VS. HEIGHT

FIGURE NO. 7

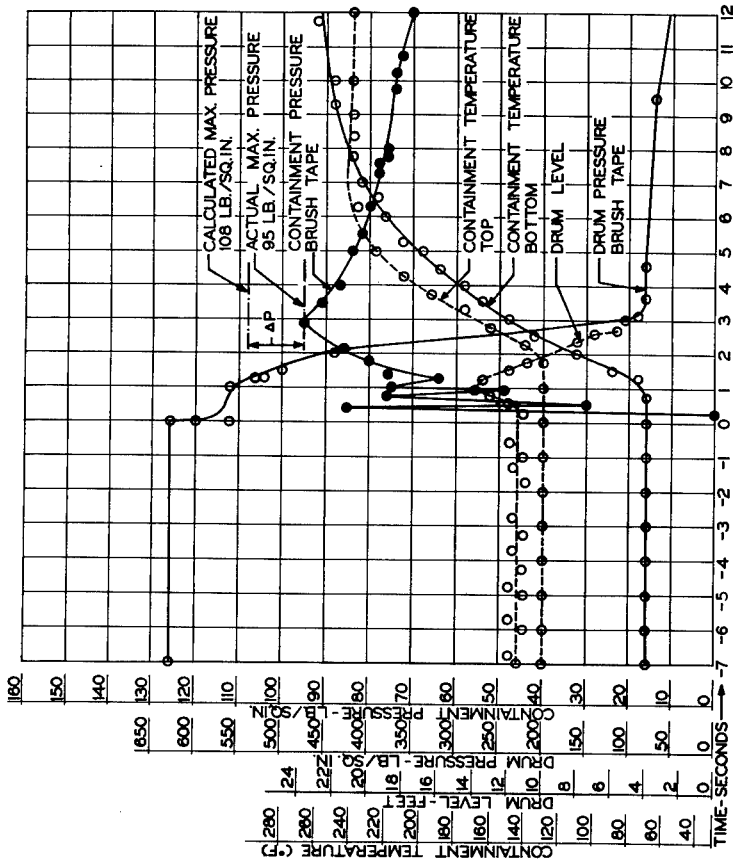

4800 LB BOILING WATER VESSEL
 NO COLD WATER IN CONTAINMENT VESSEL
 TEST NO 11 AUGUST 13, 1959
 FIGURE NO. 6

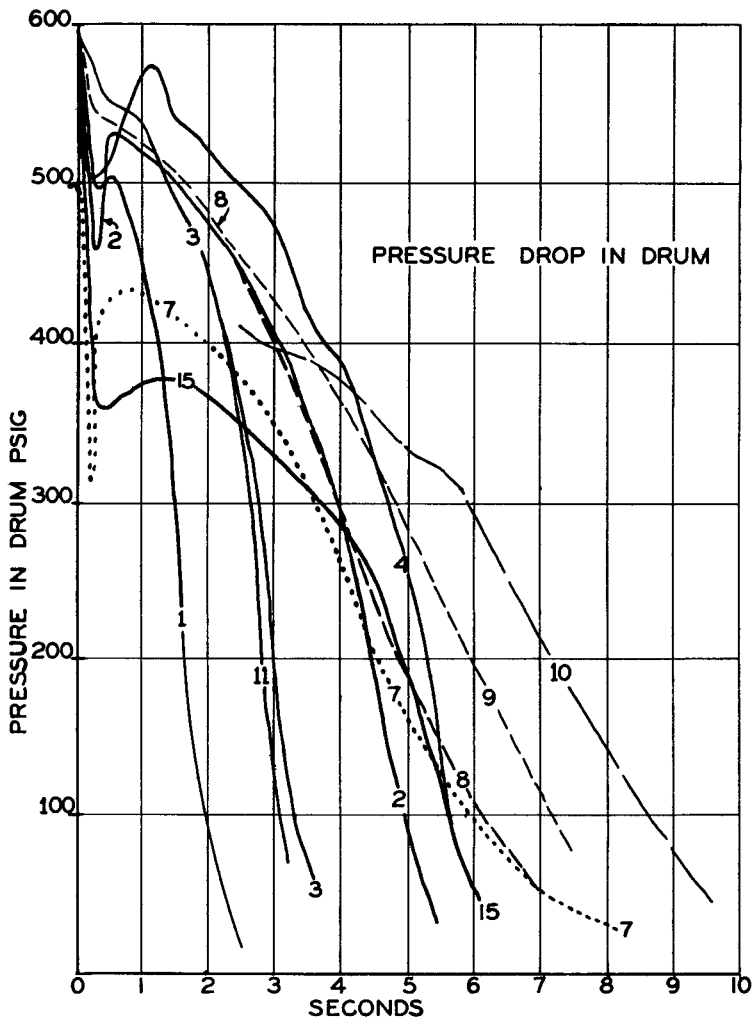

FIGURE NO. 9

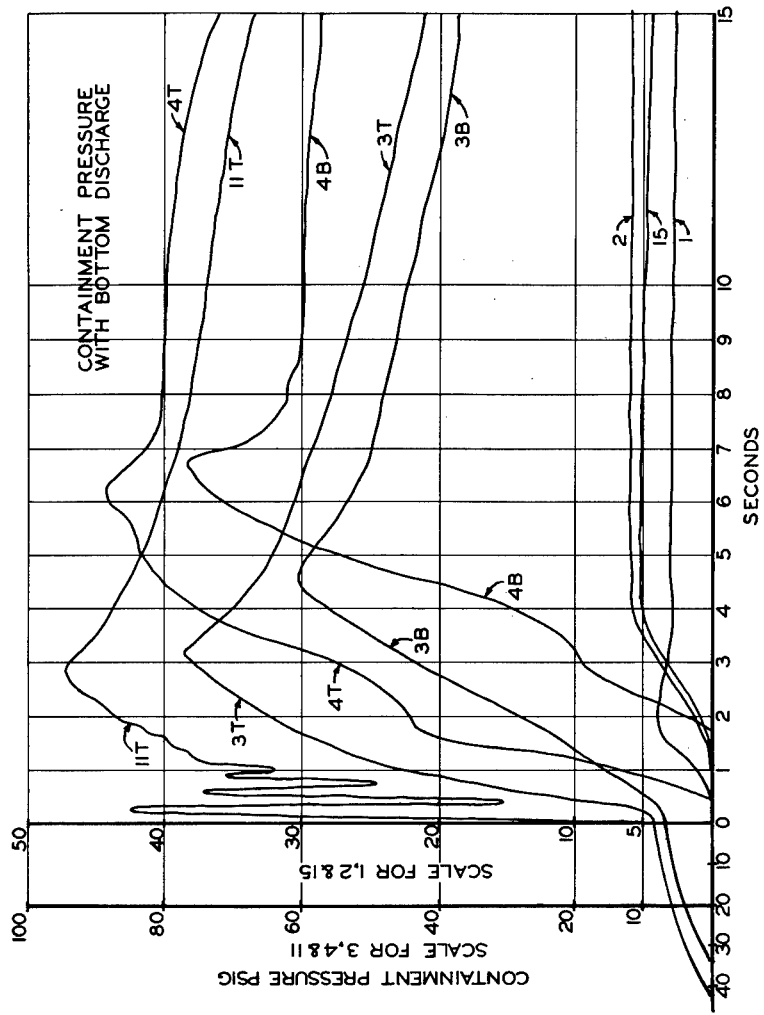

FIGURE NO. 10

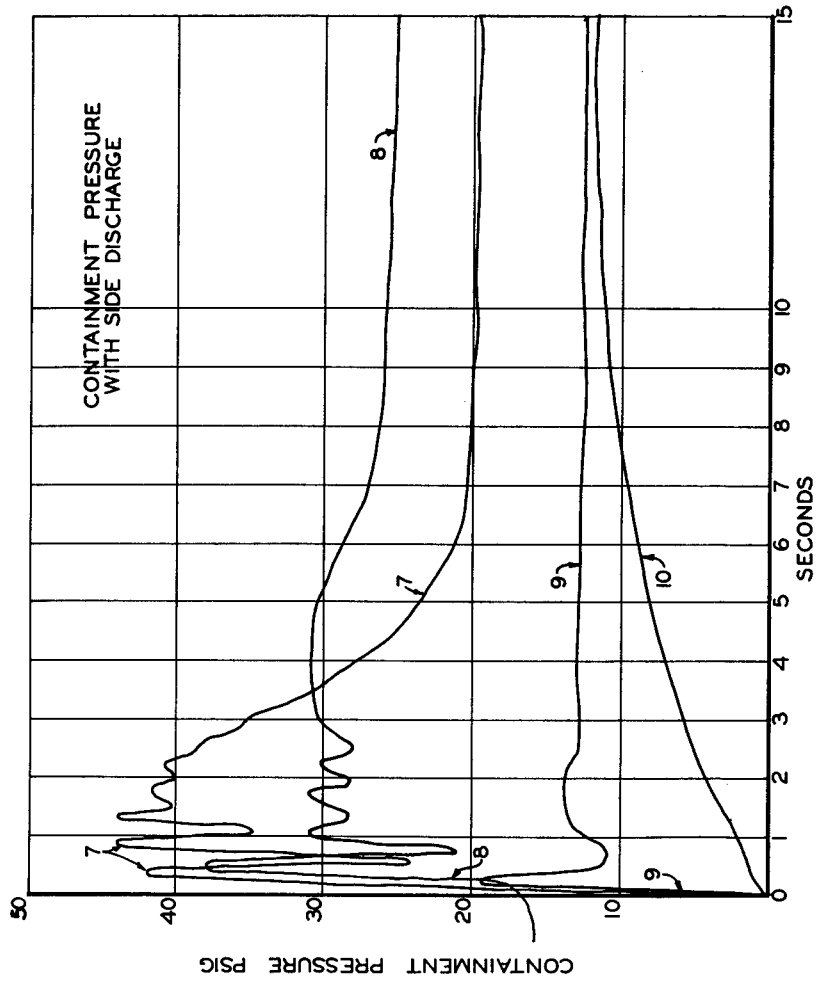
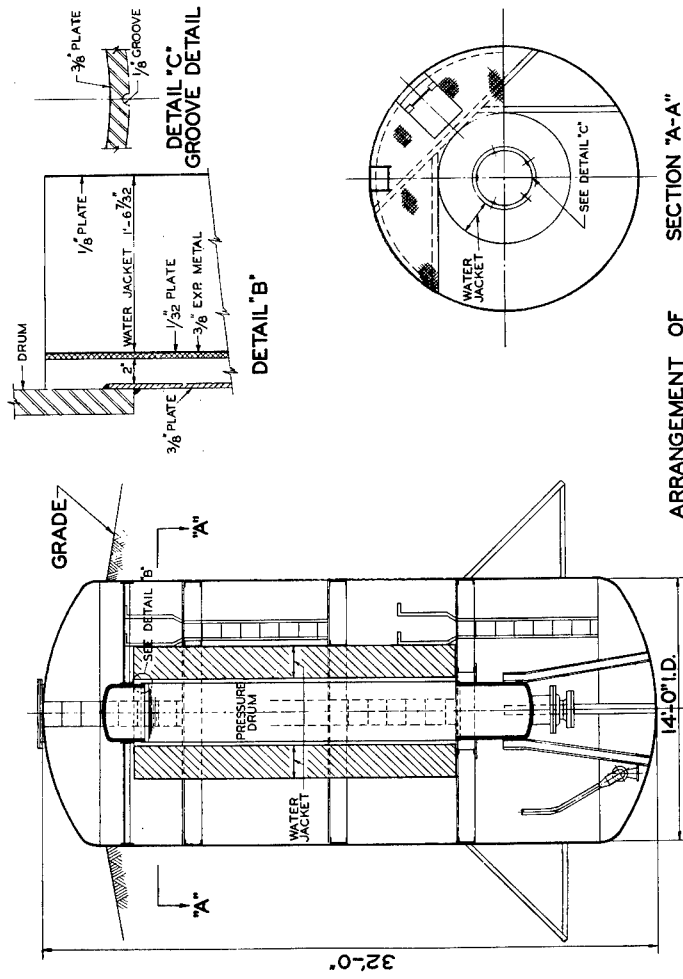

FIGURE NO. 11



ARRANGEMENT OF SECTION "A-A"

FINAL TEST

FIGURE NO. 12

BRUSH RECORDER TAPE

DRUM PRESSURE

CONTAINMENT PRESS.

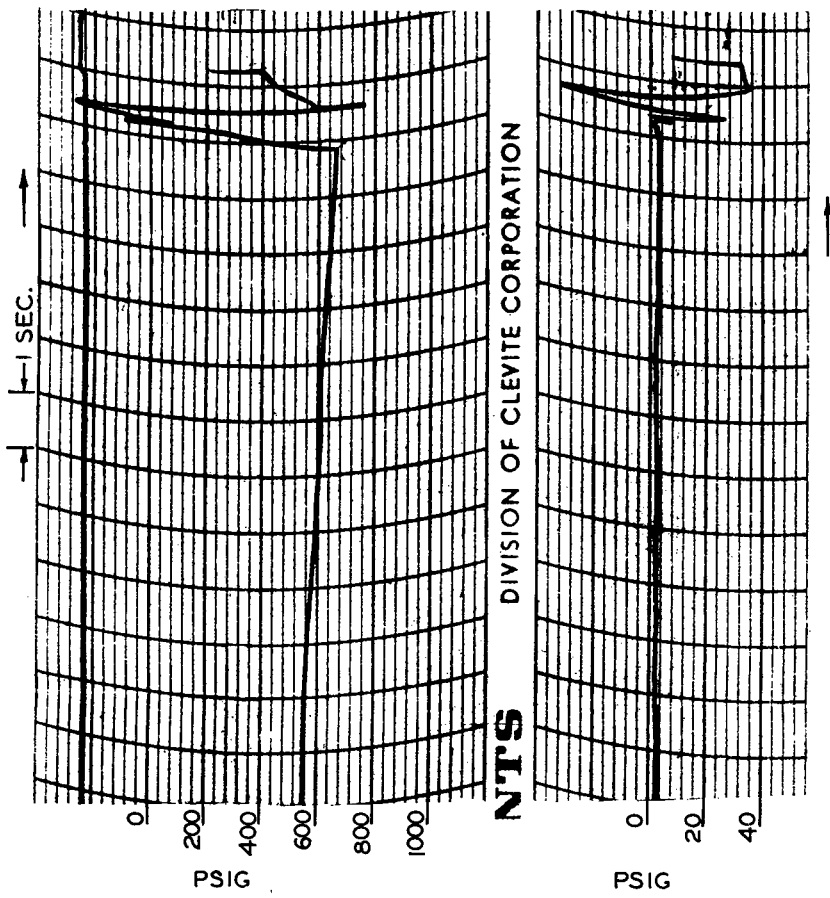
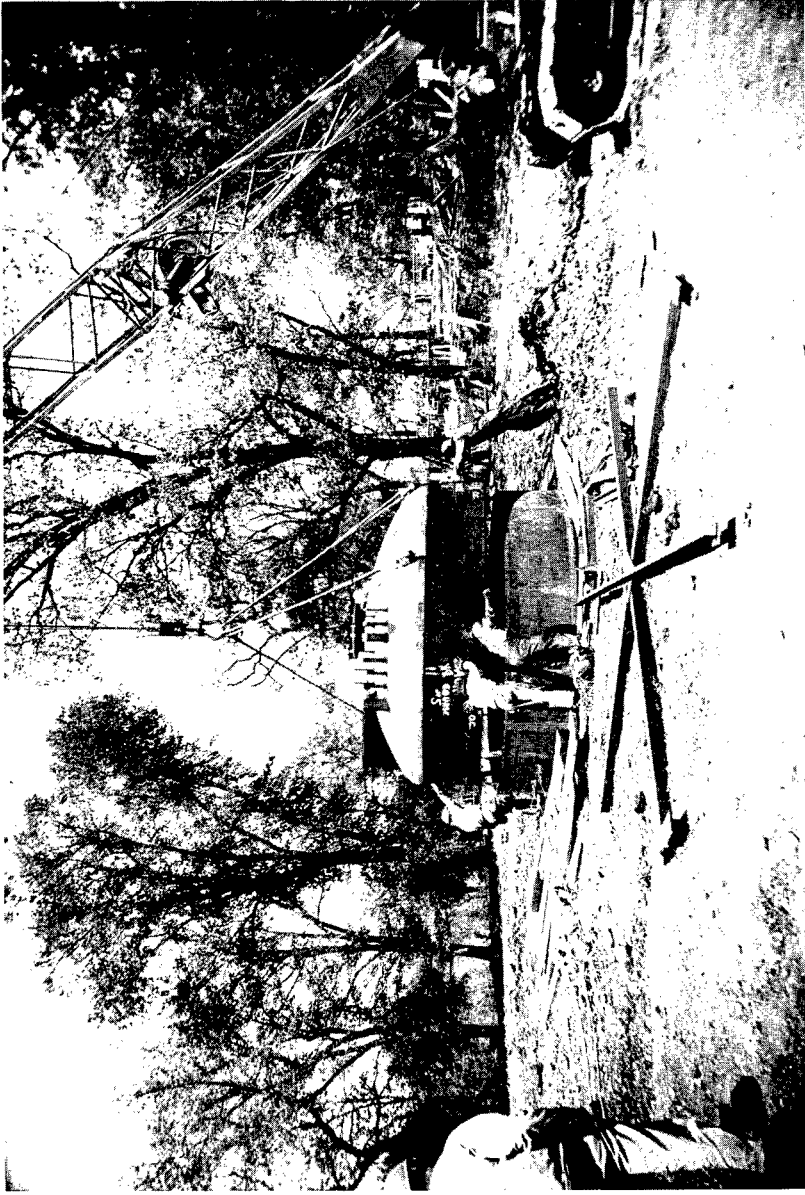
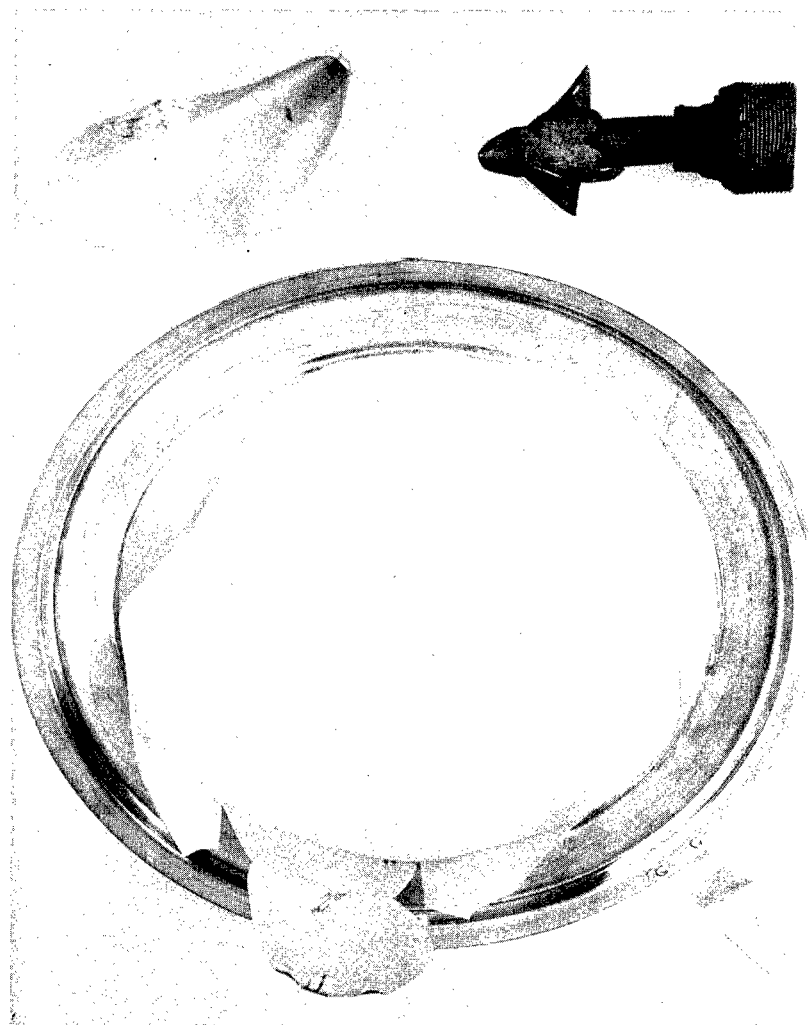

FIGURE NO. 13



PICTURE NO. 1



PICTURE NO. 2

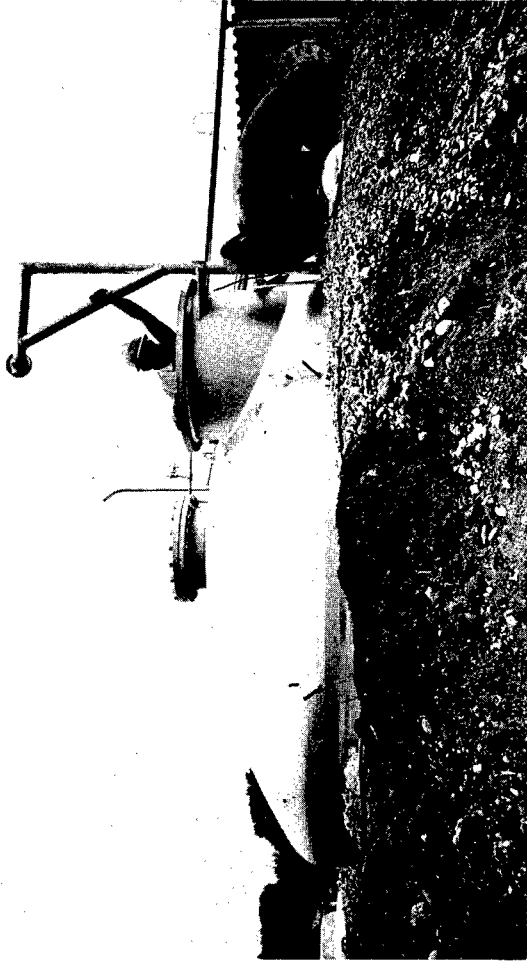

PICTURE NO. 3

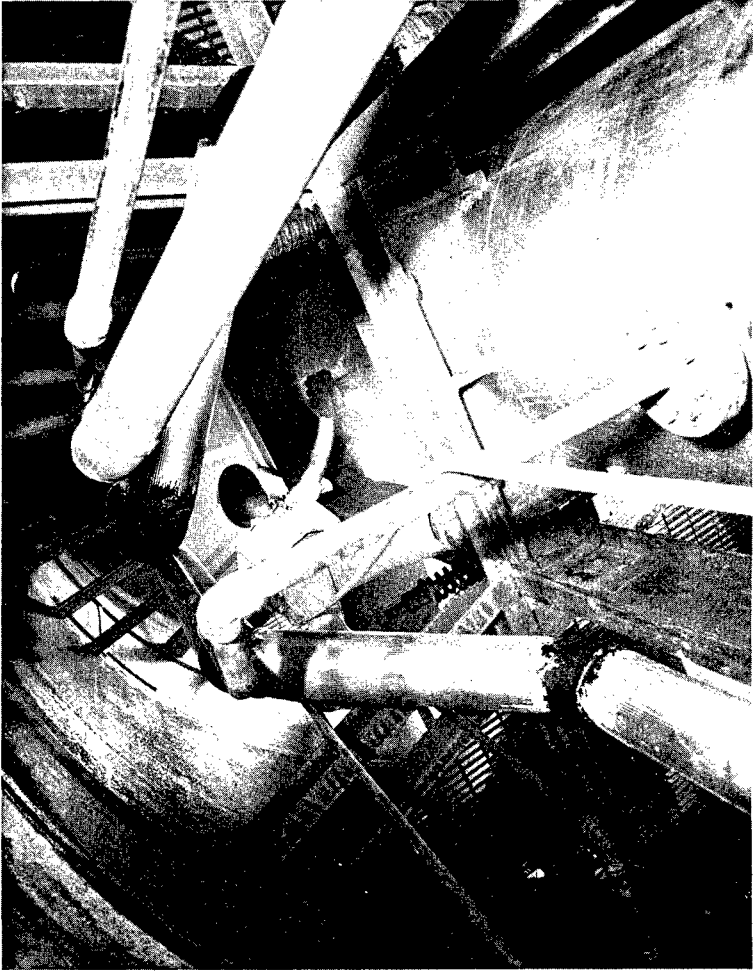

PICTURE NO. 4

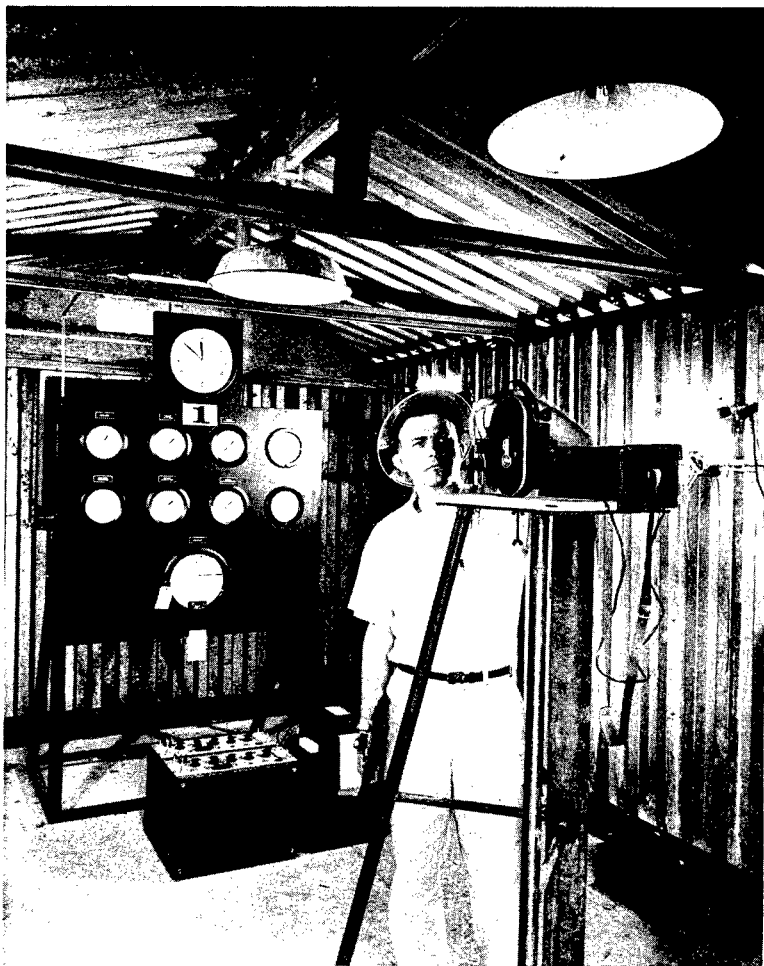

PICTURE NO. 5