

FINAL REPORT
JANUARY 1996

REPORT NO. 96-02

PA116 CONTAINERS ON A
HARDWOOD PALLET WITH
METAL ADAPTER
FIRST ARTICLE TESTING (FAT)

19961223 051

DECS QUALITY CONTROL

Prepared for:
U.S. Army Armament Research, Development
and Engineering Center
ATTN: AMSTA-AR-ESK
Rock Island, IL 61299-7300

Distribution Unlimited

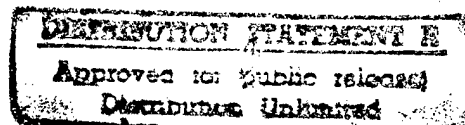

VALIDATION ENGINEERING DIVISION
SAVANNA, ILLINOIS 61074-9639

AVAILABILITY NOTICE

A copy of this report will be furnished each attendee on automatic distribution. Additional copies or authority for reprinting may be obtained by written request from Director, U.S. Army Defense Ammunition Center and School, ATTN: SIOAC-DEV, Savanna, IL 61074-9639.

DISTRIBUTION INSTRUCTIONS

Destroy this report when no longer needed. Do not return.

Citation of trade names in this report does not constitute an official endorsement.

The information contained herein will not be used for advertising purposes.

UNCLASSIFIED

SECURITY CLASSIFICATION OF THIS PAGE

REPORT DOCUMENTATION PAGE				Form Approved OMB No. 0704-0188	
1a. REPORT SECURITY CLASSIFICATION UNCLASSIFIED		1b. RESTRICTIVE MARKINGS			
2a. SECURITY CLASSIFICATION AUTHORITY		3. DISTRIBUTION / AVAILABILITY OF REPORT UNLIMITED			
2b. DECLASSIFICATION / DOWNGRADING SCHEDULE					
4. PERFORMING ORGANIZATION REPORT NUMBER(S) 96-02		5. MONITORING ORGANIZATION REPORT NUMBER(S)			
6a. NAME OF PERFORMING ORGANIZATION U.S. Army Defense Ammunition Center and School		6b. OFFICE SYMBOL (if applicable) SIOAC-DEV	7a. NAME OF MONITORING ORGANIZATION		
6c. ADDRESS (City, State, and ZIP Code) ATTN: SIOAC-DEV Savanna, IL 61074-9639		7b. ADDRESS (City, State, and ZIP Code)			
8a. NAME OF FUNDING / SPONSORING ORGANIZATION U.S. Army Armament Research, Development and Engineering Center		8b. OFFICE SYMBOL (if applicable) AMSTA-AR-ESK	9. PROCUREMENT INSTRUMENT IDENTIFICATION NUMBER		
8c. ADDRESS (City, State, and ZIP Code) ATTN: AMSTA-AR-ESK Rock Island, IL 61299-7300		10. SOURCE OF FUNDING NUMBERS			
		PROGRAM ELEMENT NO.	PROJECT NO.	TASK NO.	WORK UNIT ACCESSION NO.
11. TITLE (Include Security Classification) PA116 Containers on a Hardwood Pallet with Metal Adapter First Article Testing (FAT)					
12. PERSONAL AUTHOR(S) Bradley J. Haas					
13a. TYPE OF REPORT Final		13b. TIME COVERED FROM _____ TO _____		14. DATE OF REPORT (Year, Month, Day) 1996 January	15. PAGE COUNT
16. SUPPLEMENTARY NOTATION					
17. COSATI CODES			18. SUBJECT TERMS (Continue on reverse if necessary and identify by block number)		
FIELD	GROUP	SUB-GROUP			
19. ABSTRACT (Continue on reverse if necessary and identify by block number) The U.S. Army Defense Ammunition Center and School (USADACS), Validation Engineering Division (SIOAC-DEV), was tasked by the U.S. Army Armament Research, Development and Engineering Center (ARDEC) to conduct First Article Testing (FAT) on a metal top adapter for the PA116 container produced by Conco, Inc., Louisville, KY. First article testing consists of MIL-STD-1660, Design Criteria for Ammunition Unit Loads, testing being performed on a palletized unit load of PA116 containers on a hardwood pallet. This report contains test results of PA116 containers on a hardwood pallet with metal top adapter meeting MIL-STD-1660 requirements.					
20. DISTRIBUTION / AVAILABILITY OF ABSTRACT <input checked="" type="checkbox"/> UNCLASSIFIED/UNLIMITEDSAME AS RPT.DTIC USERS <input type="checkbox"/>			21. ABSTRACT SECURITY CLASSIFICATION UNCLASSIFIED		
22a. NAME OF RESPONSIBLE INDIVIDUAL JEROME H. KROHN		22b. TELEPHONE (Include Area Code) 815-273-8929		22c. OFFICE SYMBOL SIOAC-DEV	

U.S. ARMY DEFENSE AMMUNITION CENTER AND SCHOOL
VALIDATION ENGINEERING DIVISION
SAVANNA, IL 61074-9639

REPORT NO. 96-02

PA116 CONTAINERS ON A HARDWOOD PALLET WITH METAL ADAPTER
FIRST ARTICLE TESTING (FAT)

TABLE OF CONTENTS

PART	PAGE NO.
1. INTRODUCTION	1-1
A. BACKGROUND	1-1
B. AUTHORITY	1-1
C. OBJECTIVE	1-1
D. CONCLUSION	1-1
2. ATTENDEES	2-1
3. TEST PROCEDURES	3-1
4. TEST EQUIPMENT	4-1
5. TEST RESULTS	5-1
6. PHOTOGRAPH	6-1
7. DRAWING	7-1

PART 1

INTRODUCTION

A. BACKGROUND. The U.S. Army Defense Ammunition Center and School (USADACS), Validation Engineering Division (SIOAC-DEV), was tasked by the U.S. Army Armament Research, Development and Engineering Center (ARDEC) to conduct MIL-STD-1660 tests on a palletized unit load consisting of PA116 containers on a hardwood pallet with a metal top adapter produced by Conco, Inc., Louisville, KY.

B. AUTHORITY. This test was conducted IAW mission responsibilities delegated by the U.S. Army Armament, Munitions and Chemical Command (AMCCOM), Rock Island, IL.

C. OBJECTIVE. The objective of this test is to ascertain that the palletized unit load consisting of PA116 containers on a hardwood pallet with a metal top adapter is not damaged during transportation.

D. CONCLUSION. The palletized unit load completed testing with no damage to the PA116 containers or the top adapter. Only minor movement of the containers occurred. The palletized unit load passed MIL-STD-1660, Design Criteria for Ammunition Unit Loads, requirements.

PART 2

18 JANUARY 1996

ATTENDEES

Bradley J. Haas
Mechanical Engineer
DSN 585-8336
815-273-8336

Director
U.S. Army Defense Ammunition Center
and School
ATTN: SIOAC-DEV
Savanna, IL 61074-9639

Jerome H. Krohn
Supervisory General Engineer
DSN: 585-8908
815-273-8908

Director
U.S. Army Defense Ammunition Center
and School
ATTN: SIOAC-DEV
Savanna, IL 61074-9639

Sandra M. Schultz
Industrial Engineer
DSN 585-8086
815-273-8086

Director
U.S. Army Defense Ammunition Center
and School
ATTN: SIOAC-DES
Savanna, IL 61074-9639

Thomas J. Michels
Supervisory General Engineer
DSN: 585-8080
815-273-8080

Director
U.S. Army Defense Ammunition Center
and School
ATTN: SIOAC-DES
Savanna, IL 61074-9639

John M. Sprague
Industrial Engineer
DSN 585-8088
815-273-8088

Director
U.S. Army Defense Ammunition Center
and School
ATTN: SIOAC-DES
Savanna, IL 61074-9639

Mark Rehmstedt
DSN 793-8206
309-782-8206

Commander
U.S. Army Armament Research, Development
and Engineering Center
ATTN: AMSTA-AR-ESK
Rock Island, IL 61299-7300

Robert J. Sobiech
502-962-2132

Conco, Inc.
P.O. Box 19076
4000 Oaklawn Drive
Louisville, KY 40219-0076

Tom Wolf
502-962-2137

Conco, Inc.
P.O. Box 19076
4000 Oaklawn Drive
Louisville, KY 40219-0076

Steven F. Diehl
813-578-8128

Olin Ordnance
10101 9th Street North
St. Petersburg, FL 33716

Roy Buckrup

Commander
U.S. Army Industrial Operations Command
ATTN: AMSIO-IOE-P
Rock Island, IL 61299-6000

PART 3

TEST PROCEDURES

The test procedures outlined in this section were extracted from MIL-STD-1660, Design Criteria for Ammunition Unit Loads, 8 April 1977. This standard identifies nine steps that a unitized load must undergo if it is to be considered acceptable. The five tests that were conducted on the test pallets are summarized below.

A. STACKING TESTS. The unit load was loaded to simulate a stack of identical unit loads stacked 16 feet high, for a period of one hour. This stacking load was simulated by subjecting the unit load to a compression weight equal to an equivalent 16-foot stacking height. The compression load was calculated in the following manner. The unit load weight was divided by the unit load height in inches and multiplied by 192. The resulting number was the equivalent compressive force of a 16-foot-high load.

B. REPETITIVE SHOCK TEST. The repetitive shock test was conducted IAW Method 5019, Federal Standard 101. The test procedure is as follows: The test specimen was placed on, but not fastened to, the platform. With the specimen in one position, the platform was vibrated at 1/2-inch amplitude (1-inch double amplitude) starting at a frequency of approximately 3 cycles per second. The frequency was steadily increased until the package left the platform. The resonant frequency was achieved when a 1/16-inch-thick feeler gage momentarily slid freely between every point on the specimen in contact with the platform at some instance during the cycle or a platform acceleration achieved 1 ± 0.1 Gs. Midway into the testing period, the specimen was rotated 90 degrees and the test continued for the duration. Unless failure occurred, the total time of vibration was two hours if the specimen was tested in one position and three hours for more than one position.

C. EDGEWISE ROTATIONAL DROP TEST. This test was conducted using the procedures of Method 5008, Federal Standard 101. The procedure for the edgewise rotational drop test is as follows: The specimen was placed on its skids with one end of the pallet supported on a beam 4-1/2 inches high. The height of the beam was increased if necessary to ensure that there was no support for the skids between the ends of the pallet when dropping took place, but was not high enough to cause the pallet to slide on the supports when the dropped end was raised for the drops. The unsupported end of the pallet was then raised and allowed to fall freely to the concrete, pavement, or similar underlying surface from a prescribed height. Unless otherwise specified, the height of drop for level A protection conforms to the following tabulation:

GROSS WEIGHT (WITHIN RANGE LIMITS) (Pounds)	ANY EDGE, HEIGHT OR WIDTH (WITHIN RANGE LIMITS) (Inches)	HEIGHT OF DROPS ON EDGES	
		Level A (Inches)	Level B (Inches)
150 - 250	60 - 66	36	27
250 - 400	66 - 72	32	24
400 - 600	72 - 80	28	21
600 - 1000	80 - 95	24	18
1000 - 1500	95 - 114	20	16
1500 - 2000	114 - 144	17	14
2000 - 3000	Above 145 - No limit	15	12
Above - 3000		12	9

D. INCLINE-IMPACT TEST. This test was conducted by using the procedure of Method 5023, Incline-Impact Test of Federal Standard 101. The procedure for the

incline-impact test is as follows: The specimen was placed on the carriage with the surface or edge which is to be impacted projecting at least 2 inches beyond the front end of the carriage. The carriage was brought to a predetermined position on the incline and released. If it is desired to concentrate the impact on any particular position on the container, a 4- by 4-inch timber was attached to the bumper in the desired position before the test. No part of the timber was struck by the carriage. The position of the container on the carriage and the sequence in which surfaces and edges are subjected to impacts was at the option of the testing activity and depends upon the objective of the tests. This test is to determine satisfactory requirements for a container or pack, and, unless otherwise specified, the specimen was subjected to one impact on each surface that has each dimension less than 9.5 feet. Unless otherwise specified, the velocity at time of impact was 7 feet per second.

5. SLING COMPATIBILITY TEST. Unit loads utilizing special design of non-standard pallets were lifted, swung, lowered and otherwise handled as necessary, using slings of the types normally used for handling the unit loads under consideration. Slings were easily attached and removed. Danger of slippage or disengagement when the load is suspended is cause for rejection of the unit load.

PART 4

TEST EQUIPMENT

A. PA116 Containers on Wooden Pallet with Metal Top Adapter (Test Sample No. 1).

- | | |
|--------------------|---------------|
| 1. Drawing Number: | 19-48-4079/7B |
| 2. Width: | 40 inches |
| 3. Length: | 44-1/2 inches |
| 4. Height: | 52-5/8 inches |
| 5. Weight Loaded: | 2,580 pounds |

B. PA116 Containers on Wooden Pallet with Metal Top Adapter (Test Sample No. 2).

- | | |
|--------------------|---------------|
| 1. Drawing Number: | 19-48-4079/7B |
| 2. Width: | 40 inches |
| 3. Length: | 44-1/2 inches |
| 4. Height: | 52-5/8 inches |
| 5. Weight Loaded: | 2,610 pounds |

C. Compression Tester.

- | | |
|-----------------------|----------------------|
| 1. Manufacturer: | Ormond Manufacturing |
| 2. Platform: | 60- by 60-inches |
| 3. Compression Limit: | 50,000 pounds |
| 4. Tension Limit: | 50,000 pounds |

D. Transportation Simulator.

- | | |
|------------------|--------------------|
| 1. Manufacturer: | Gaynes Laboratory |
| 2. Capacity: | 6,000 pound pallet |
| 3. Displacement: | 1/2 inch amplitude |
| 4. Speed: | 50 to 400 rpm |
| 5. Platform: | 5- by 8-foot |

E. Inclined Plane.

- | | |
|------------------|--------------------|
| 1. Manufacturer: | Conbur Incline |
| 2. Type: | Impact Tester |
| 3. Grade: | 10 percent incline |
| 4. Length: | 12 foot |

PART 5

TEST RESULTS

TEST OBSERVATIONS. While banding each sample, the pallets became warped. This caused the majority of the weight to be supported by the center skid. Also, one wing of the pallet of test sample no. 1 was broken prior to testing.

TEST SAMPLE NO. 1:

A. STACKING TEST. The test sample was initially loaded to 9,000-pounds compression. The compression was released after one hour. No damage was noted during this test.

B. REPETITIVE SHOCK TEST. The duration of the test was 90 minutes for each orientation of the pallet. The transportation simulator was operated at 144 rpm while the pallet was oriented in the longitudinal direction. For the lateral orientation, the transportation simulator was operated at 90 rpm. The warped shape of the pallet caused the pallet to rock in addition to leaving the surface. During the lateral vibration, one of the buffer boards raised from the pallet slightly. No damage occurred to the pallet, load, or the top adapter.

C. EDGEWISE ROTATIONAL DROP TEST. Each side of the pallet was placed on a beam displacing it 4-1/2-inches above the floor. The opposite end of the pallet was raised to a height of 24 inches, then dropped. A height of 22 inches was employed instead of the specified 24 inches in the lateral direction due to the dimensions of the pallet. After the first drop, one of the corner containers in the top row had become unnested. The second drop put the container back into the nested position. After the completion of all four drops, a 1/4-inch gap existed between the outside container of the top row and the side of the top adapter.

D. INCLINE-IMPACT TEST. The inclined plane was set to allow the pallet to travel 8 feet prior to impacting a stationary wall. The pallet was rotated clockwise after each impact, until all four sides had been tested. The containers remained in a nested position with no damage noted.

E. SLING COMPATIBILITY TEST. The unitized load was lifted by the top adapter using the following: 4 slings, 3 slings, 2 slings diagonal from each other, 2 slings on the same side, 2 slings on the same end, and 1 sling. During the lifts, the top adapter appeared to deform. Upon release of force, the top adapter returned to its original shape. While lowering the pallet after a lift, one wing of the pallet broke off.

F. END OF TEST INSPECTION. No further damage occurred to the components of the palletized unit load.

TEST SAMPLE NO. 2:

A. STACKING TEST. The test sample was initially loaded to 9,000-pounds compression. The compression was released after one hour. No damage was noted during this test.

B. REPETITIVE SHOCK TEST. The duration of the test was 90 minutes for each orientation of the pallet. The transportation simulator was operated at 140 rpm while the pallet was oriented in the longitudinal direction. For the lateral orientation, the transportation simulator was operated at 90 rpm. The warped shape of the pallet caused the pallet to rock in addition to leaving the surface. No damage occurred to the pallet, load, or the top adapter.

C. EDGEWISE ROTATIONAL DROP TEST. Each side of the pallet was placed on a beam displacing it 4-1/2-inches above the floor. The opposite end of the pallet was raised to a height of 24 inches, then dropped. A height of 22 inches was employed instead of the specified 24 inches in the lateral direction due to the dimensions of the pallet. After the first drop, a space

existed between the top adapter and the top of the containers in the center columns where the pallet curved down. The fourth drop caused one of the corner containers in the top row to become unnested.

D. INCLINE-IMPACT TEST. The inclined plane was set to allow the pallet to travel 8 feet prior to impacting a stationary wall. The pallet was rotated clockwise after each impact, until all four sides had been tested. Impact no. 1 produced an additional 2 containers in the top row to become unnested. Impact no. 2 produced no damage. The third impact placed one of the unnested containers back into a nested position. The fourth impact placed both the remaining unnested containers back into the nested position.

E. SLING COMPATIBILITY TEST. The palletized unit load was lifted by the top adapter using the following: 4 slings, 3 slings, 2 slings diagonal from each other, 2 slings on the same side, 2 slings on the same end, and 1 sling. During the lifts, the top adapter appeared to deform. Upon the release of force, the adapter returned to its original shape.

F. END OF TEST INSPECTION. No further damage occurred to the components of the palletized unit load.

PART 6

PHOTOGRAPH

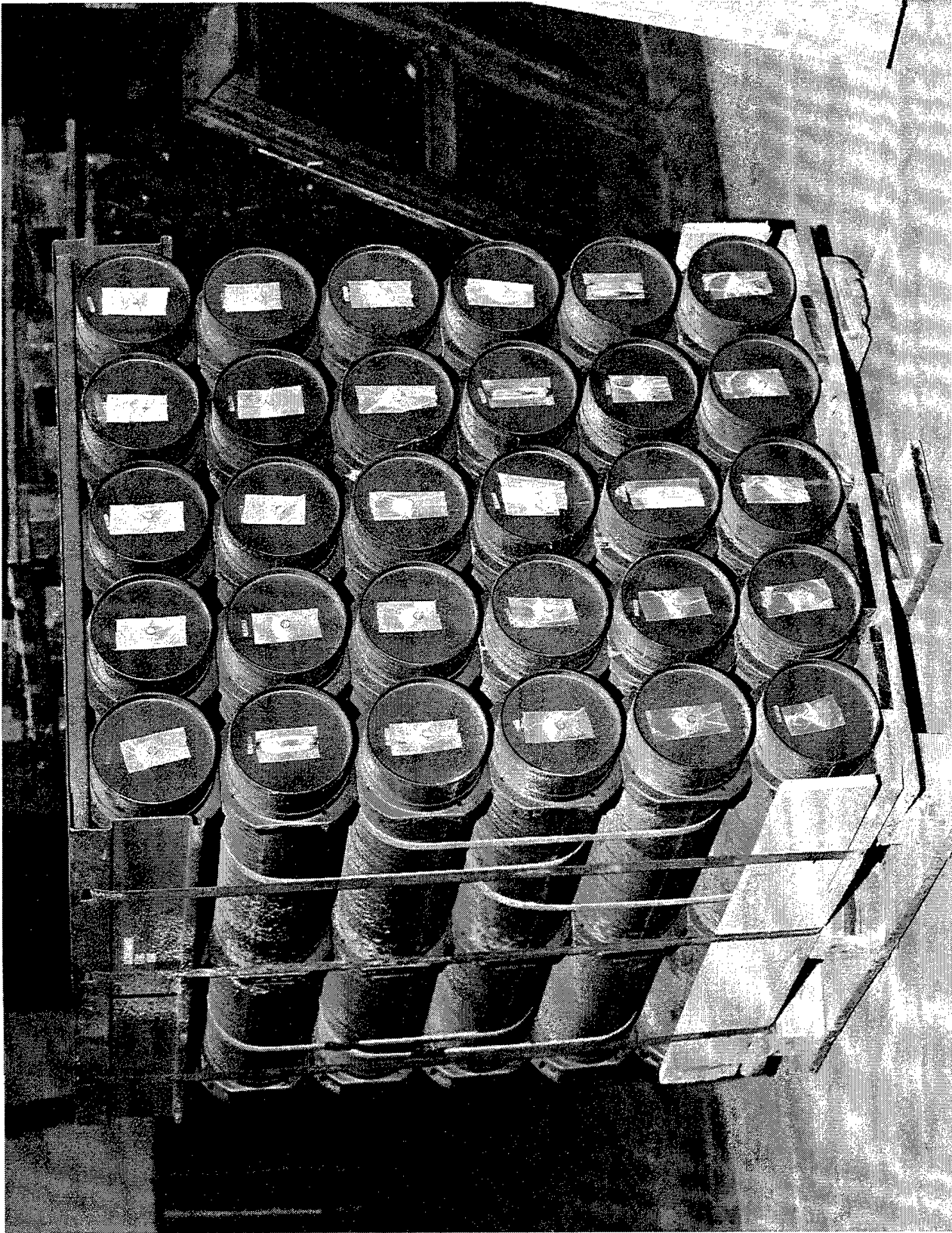

U.S. ARMY DEFENSE AMMUNITION CENTER AND SCHOOL -
SAVANNA, IL

AO317-SCN96-81-1519. This photo shows the configuration of the test load. Note the broken wing on the skid.

PART 7

DRAWING

APPENDIX 7B

UNITIZATION PROCEDURES FOR COMPLETE ROUNDS PACKED IN CYLINDRICAL METAL CONTAINERS ON 4-WAY ENTRY PALLETS *

PA116 SERIES CONTAINER

INDEX

<u>ITEM</u>	<u>PAGE(S)</u>
PALLET UNIT DATA - - - - -	2
GENERAL NOTES - - - - -	3
UNIT DETAIL - - - - -	4
DUNNAGE DETAILS - - - - -	5
FILLERS AND INSTALLATION PROCEDURES FOR OMITTED CONTAINERS- - - - -	6,7
BLANK PAGE - - - - -	8

NOTICE: THIS APPENDIX CANNOT STAND ALONE BUT MUST BE USED IN CONJUNCTION WITH THE BASIC UNITIZATION PROCEDURES DRAWING 19-48-4079-20PM1002.

* SEE GENERAL NOTE "L" ON PAGE 3.

DISTRIBUTION STATEMENT A.

APPROVED FOR PUBLIC RELEASE;
DISTRIBUTION IS UNLIMITED.

DO NOT SCALE

U.S. ARMY MATERIEL COMMAND DRAWING				
APPROVED, U.S. ARMY ARMAMENT, MUNITIONS AND CHEMICAL COMMAND AMSTA-ARA-ESK AMSMC-TMJ	DRAFTSMAN		INGEBORG DEPPE	
	ENGINEER		SANDRA M. SCHULTZ	
	SUPPLY ENGINEERING DIVISION	TRANSPORTATION ENGINEERING DIVISION	VALIDATION ENGINEERING DIVISION	
APPROVED BY ORDER OF COMMANDING GENERAL, U.S. ARMY MATERIEL COMMAND	LOGISTICS ENGINEERING OFFICE			
NOVEMBER 1987				
U.S. ARMY DEFENSE AMMUNITION CENTER AND SCHOOL	CLASS	DIVISION	DRAWING	FILE
REVISION NO. 3 NOVEMBER 1994	19	48	4079/ 7B	20PM 1002
SEE THE REVISION LISTING ON PAGE 2				

PALLET UNIT DATA				
ITEMS INCLUDED		HAZARD CLASS AND DIVISION		APPROX WEIGHT LBS
NSN	DODIC	OD CLASS	COMP GROUP	
1315				
01-250-8636	C784	(08)1.2	C	2,412
01-369-6612	C784	(08)1.2	C	2,412
01-242-4796	C785	(08)1.2	C	2,082
01-288-5545	C785	(08)1.2	C	2,082

- HAZARD CLASSIFICATION DATA CONTAINED IN THE ABOVE CHART IS FOR GUIDANCE AND INFORMATIONAL PURPOSES ONLY. VERIFICATION OF THE SPECIFIED DATA SHOULD BE MADE BY CONSULTING THE MOST RECENT JOINT HAZARD CLASSIFICATION SYSTEM LISTING OR OTHER APPROVED LISTING(S).

REVISIONS

REVISION NO. 1, DATED MARCH 1989,
CONSISTS OF:

1. CHANGING THE OD CLASSES IN THE "PALLET UNIT DATA" CHART.
2. ADDING GENERAL NOTE "N".
3. ADDING ITEM BY NATIONAL STOCK NUMBER TO "PALLET UNIT DATA" CHART.

REVISION NO. 2, DATED MAY 1994,
CONSISTS OF:

1. CHANGING DRAWING IN ACCORDANCE WITH ECP M3K3014.

REVISION NO. 3, DATED NOVEMBER 1994,
CONSISTS OF:

1. CHANGING DRAWING IN ACCORDANCE WITH ECP M4T3006 AND ECP M3T4321.

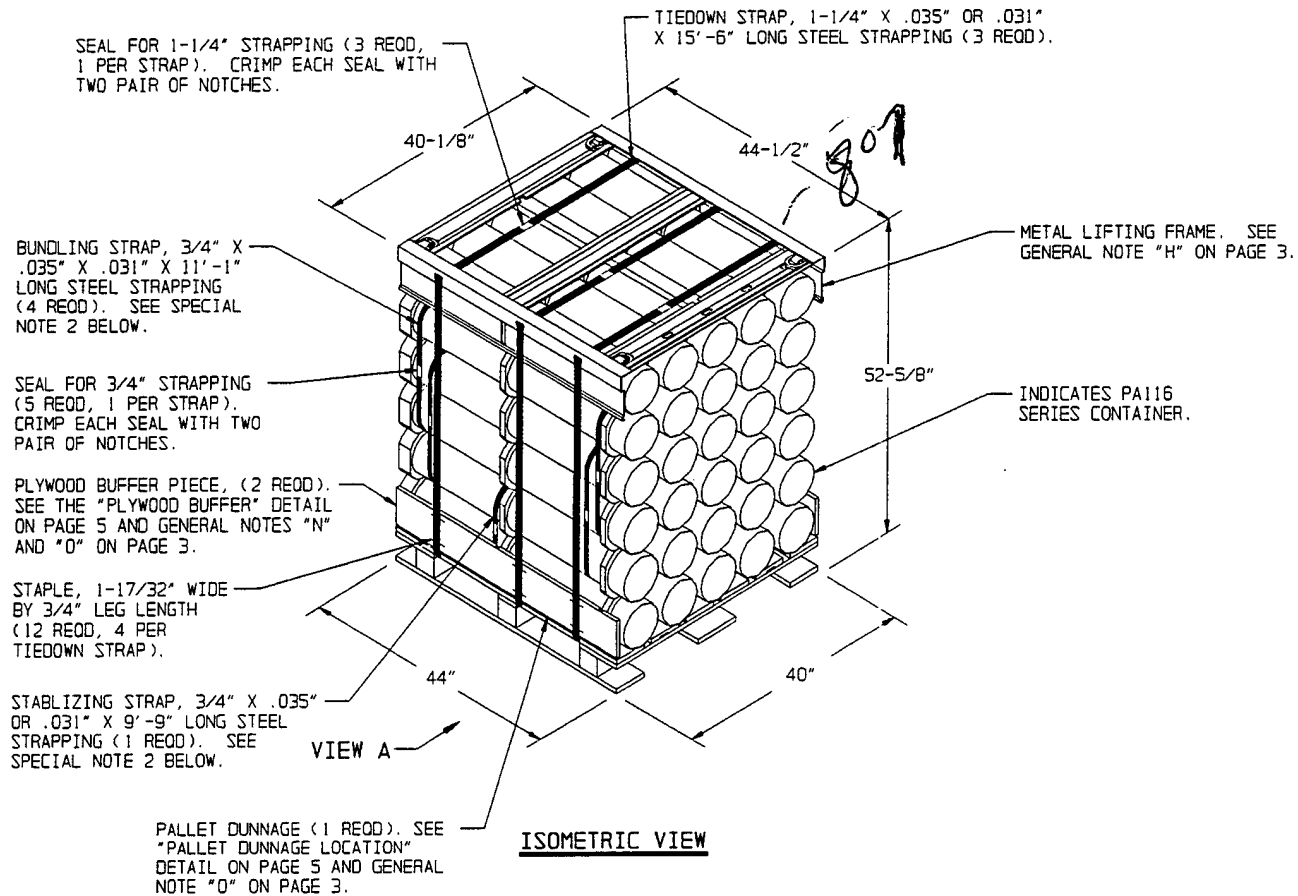

SPECIAL NOTES:

1. ALTHOUGH THE CONTAINERS DEPICTED IN THE UNIT LOAD ABOVE ARE CONSTRUCTED WITH INTERLOCKING DEVICES, THE INTERLOCKS WILL NOT FUNCTION PROPERLY UNLESS THE CONTAINERS ARE POSITIONED SO THAT THE "PINS" OF THE INTERLOCKS ARE IN AN UPRIGHT ORIENTATION. THIS ORIENTATION WILL PRECLUDE INTERFERENCE OF THE "PINS" AND THE PLYWOOD PALLET DUNNAGE AND WILL AID IN THE PREVENTION OF CONTAINER MOVEMENT, BOTH Laterally AND LONGITUDINALLY, DURING SHIPMENT OF THE UNIT LOAD.
2. BUNDLING STRAPS AND STABILIZING STRAP MUST BE TENSIONED AND SEALED PRIOR TO THE APPLICATION OF THE TIEDOWN STRAPS. ALL STRAPS MUST BE INSTALLED AS CLOSE AS POSSIBLE TO THE CONTAINER RINGS. **CAUTION:** STRAPS MUST NOT BE ALLOWED TO OVERLAP.

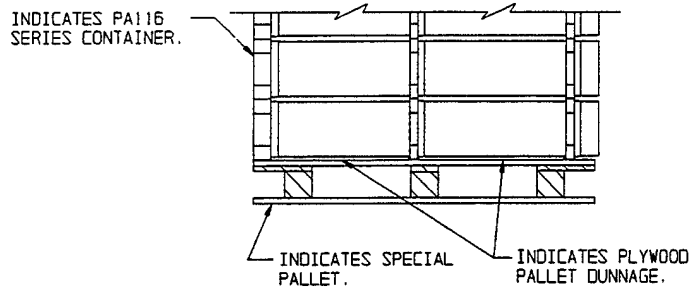

PARTIAL VIEW A
(PLYWOOD BUFFER HAS BEEN OMITTED FOR CLARITY).

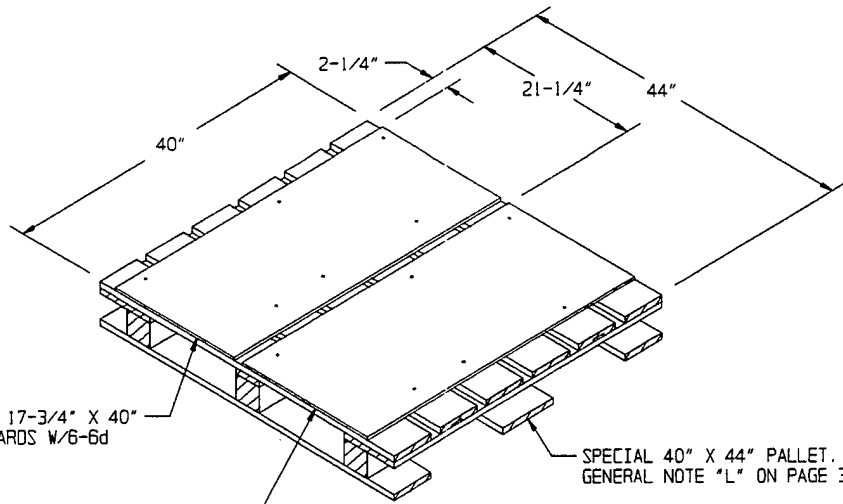

DECK DUNNAGE PLYWOOD, 3/8" X 17-3/4" X 40"
(1 REOD). NAIL THRU DECK BOARDS W/6-6d
NAILS AND CLINCH.

DECK DUNNAGE PLYWOOD, 3/8" X 18-3/4" X 40"
(1 REOD). NAIL THRU DECK BOARDS W/6-6d
NAILS AND CLINCH.

SPECIAL 40" X 44" PALLET. SEE
GENERAL NOTE "L" ON PAGE 3.

PALLET DUNNAGE LOCATION
SEE GENERAL NOTE "O" ON PAGE 3.

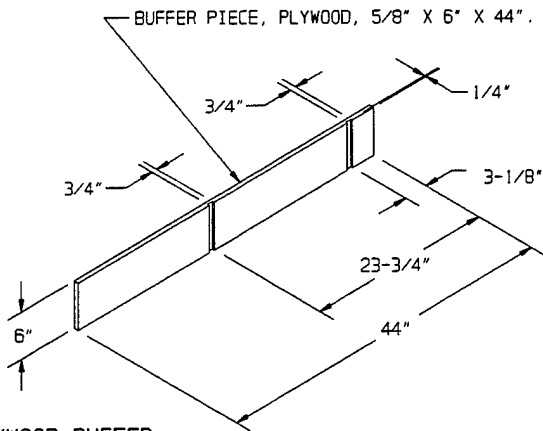

PLYWOOD BUFFER

SEE GENERAL NOTES "N" AND "O" ON PAGE 3.

BILL OF MATERIAL		
NAILS	NO. REOD	POUNDS
6d (2")	12	0.07
SPECIAL PALLET, 40" X 44"	1 REOD	77 LBS
STEEL STRAPPING, 3/4"	54.08' REOD	3.86 LBS
STEEL STRAPPING, 1-1/4"	46.50' REOD	6.64 LBS
SEAL FOR 3/4" STRAPPING	5 REOD	NIL
SEAL FOR 1-1/4" STRAPPING	3 REOD	NIL
PLYWOOD, 3/8"	10.14 SQ FT REOD	10.46 LBS
PLYWOOD, 5/8"	3.67 SQ FT REOD	6.30 LBS
STAPLES FOR 1-1/4" STRAPPING	12 REOD	NIL
METAL LIFTING FRAME	1 REOD	57 LBS

UNIT DATA

WEIGHT

CUBE	54.2 CUBIC FEET (APPROX)
CONTAINER, PA116 SERIES	30 EA AT 75 LBS - 2,250 LBS (APPROX)
DUNNAGE	85 LBS
PALLET	77 LBS
TOTAL WEIGHT	2,412 LBS (APPROX)

SPECIAL NOTES:

1. WHEN FIVE CONTAINERS ARE TO BE OMITTED FROM A PALLET UNIT. A COMPLETE LAYER OF CONTAINERS ARE TO BE OMITTED. WHEN FOUR CONTAINERS ARE TO BE OMITTED FROM A PALLET UNIT, A COMBINATION OF FILLER ASSEMBLIES DEPICTED ON PAGE 7 MUST BE USED. WHEN THREE OR LESS CONTAINERS ARE TO BE OMITTED FROM A PALLET UNIT, A COMBINATION OR ONE OF THE FILLER ASSEMBLIES DEPICTED ON PAGE 7 MAY BE USED. ALL FILLER ASSEMBLIES MUST BE INSTALLED IN THE MIDDLE OF THE LAYER OR LAYERS OF A PALLET UNIT.
2. WHEN A "FILLER A" ASSEMBLY IS USED IN COMBINATION WITH A "FILLER B" OR "FILLER C" ASSEMBLY THE "FILLER A" ASSEMBLY MUST BE POSITIONED IN THE SECOND LAYER OF CONTAINERS FROM THE TOP OF THE PALLET UNIT AND MUST HAVE ITS OVERALL HEIGHT REDUCED FROM 7-1/4" TO 7" AND ALSO 2" X 6" MATERIAL WILL BE SUBSTITUTED FOR THE 2" X 8" RIPPED TO 5-3/4" PIECES USED.
3. WHEN TWO "FILLER A" ASSEMBLIES ARE USED IN PLACE OF TWO OMITTED CONTAINERS, THE FILLER ASSEMBLIES WILL BE SEPARATED BY AT LEAST ONE CONTAINER TO INSURE PROPER FILLER ASSEMBLY RETENTION AND TO PRECLUDE ASSEMBLY INTERFERENCES.

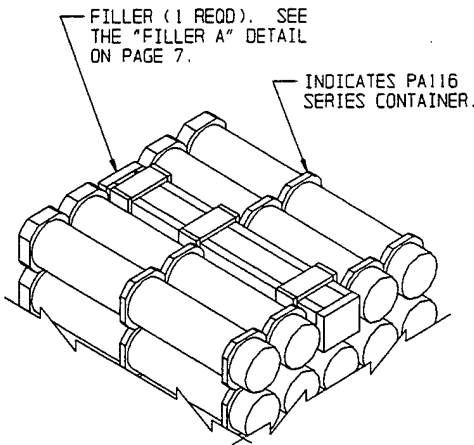

DETAIL A

THIS DETAIL DEPICTS PROCEDURES TO BE USED WHEN A STANDARD PALLET UNIT MINUS ONE CONTAINER IS TO BE UNITIZED. THE FILLER ASSEMBLY DEPICTED MUST BE INSTALLED IN THE MIDDLE OF THE TOP LAYER OF THE PALLET UNIT.

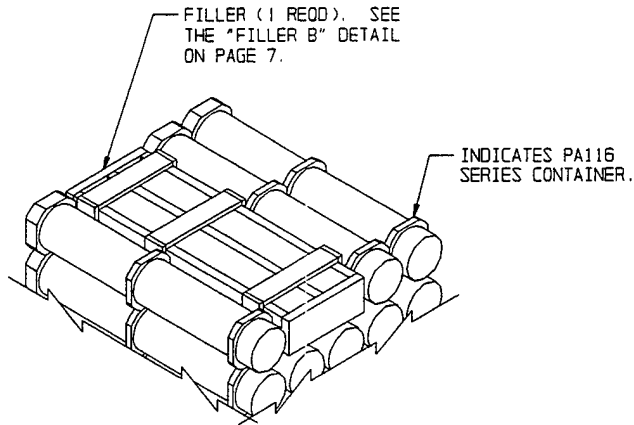

DETAIL B

THIS DETAIL DEPICTS PROCEDURES TO BE USED WHEN A STANDARD PALLET UNIT MINUS TWO CONTAINERS IS TO BE UNITIZED. THE FILLER ASSEMBLY DEPICTED MUST BE INSTALLED IN THE MIDDLE OF THE TOP LAYER OF THE PALLET UNIT.

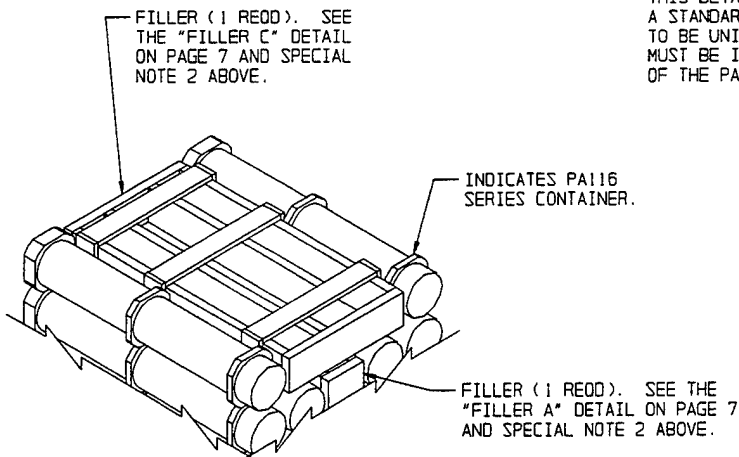

DETAIL C

THIS DETAIL DEPICTS PROCEDURES TO BE USED WHEN A STANDARD PALLET UNIT MINUS FOUR CONTAINERS IS TO BE UNITIZED. THE FILLER ASSEMBLIES DEPICTED MUST BE INSTALLED IN THE MIDDLE OF THE TOP LAYERS OF THE PALLET UNIT.

END BEARING PIECE, 2" X 8" (RIPPED TO 5-3/4") X 7 (2 REOD). NAIL TO THE TIE PIECES W/3-10d NAILS AT EACH JOINT.

FILL PIECE, 1" X 4" X 7-1/4" (6 REOD). NAIL TO THE TIE PIECE W/2-6d NAILS AND TO THE STRUTS W/2-6d NAILS AT EACH JOINT.

BELL END OF FILLER ASSEMBLY.

TIE PIECE, 2" X 8" (RIPPED TO 5-3/4") X 41-1/2" (2 REOD).

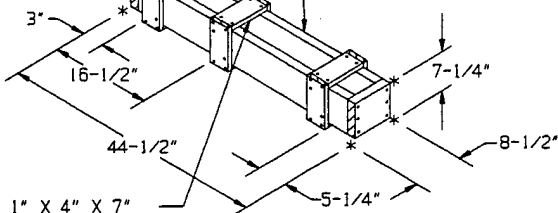

STRUT, 1" X 4" X 7" (6 REOD). NAIL TO THE TIE PIECES W/2-6d NAILS AT EACH JOINT.

FILLER A

THIS FILLER IS TO BE USED WHEN ONE CONTAINER IS TO BE OMITTED FROM A PALLET UNIT, OR IN COMBINATION WITH OTHER FILLER ASSEMBLIES.

END BEARING PIECE, 2" X 8" (RIPPED TO 5-3/4") X 14-7/8" (2 REOD). NAIL TO THE TIE PIECES W/3-10d NAILS AT EACH JOINT.

FILL PIECE, 1" X 4" X 7-1/4" (6 REOD). NAIL TO THE TIE PIECE W/2-6d NAILS AND TO THE STRUTS W/2-6d NAILS AT EACH JOINT.

TIE PIECE, 2" X 8" (RIPPED TO 5-3/4") X 41-1/2" (3 REOD).

BELL END OF FILLER ASSEMBLY.

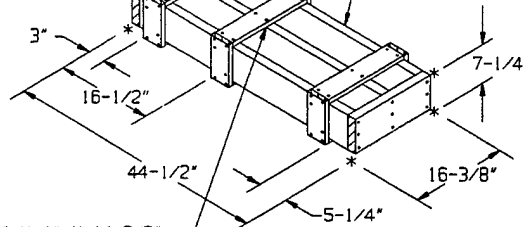

STRUT, 1" X 4" X 14-7/8" (6 REOD). NAIL TO THE TIE PIECES W/2-6d NAILS AT EACH JOINT.

FILLER B

THIS FILLER IS TO BE USED WHEN TWO CONTAINERS ARE TO BE OMITTED FROM A PALLET UNIT, OR IN COMBINATION WITH OTHER FILLER ASSEMBLIES.

END BEARING PIECE, 2" X 8" (RIPPED TO 5-3/4") X 22-5/8" (2 REOD). NAIL TO THE TIE PIECES W/3-10d NAILS AT EACH JOINT.

FILL PIECE, 1" X 4" X 7-1/4" (6 REOD). NAIL TO THE TIE PIECE W/2-6d NAILS AND TO THE STRUTS W/2-6d NAILS AT EACH JOINT.

BELL END OF FILLER ASSEMBLY.

TIE PIECE, 2" X 8" (RIPPED TO 5-3/4") X 41-1/2" (4 REOD).

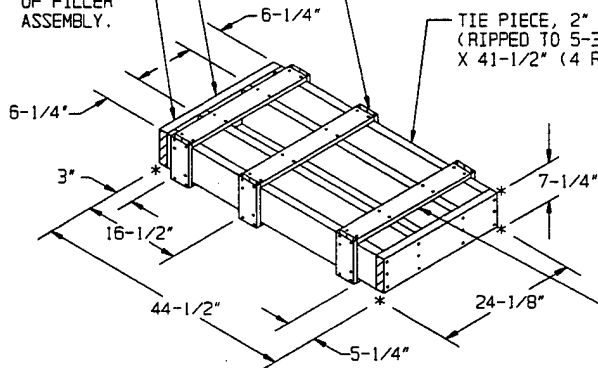

STRUT, 1" X 4" X 22-5/8" (6 REOD). NAIL TO THE TIE PIECES W/2-6d NAILS AT EACH JOINT.

FILLER C

THIS FILLER IS TO BE USED WHEN THREE CONTAINERS ARE TO BE OMITTED FROM A PALLET UNIT, OR IN COMBINATION WITH OTHER FILLER ASSEMBLIES.

