

AECD - 2691

UNITED STATES ATOMIC ENERGY COMMISSION

CALIBRATION OF PHILIPS ION GAUGE

by

J. R. Tolmie

University of California
Radiation Laboratory

NAVY RESEARCH SECTION
SCIENCE DIVISION
REFERENCE DEPARTMENT
LIBRARY OF CONGRESS

20 FEB 1950

Date of Manuscript: March 25, 1944
Date Declassified: August 25, 1949

Issuance of this document does not constitute authority for declassification of classified copies of the same or similar content and title and by the same author.

FILE COPY
NAVY RESEARCH SECTION
SCIENCE DIVISION
LIBRARY OF CONGRESS
TO BE RETURNED

DISTRIBUTION STATEMENT II
Approved for public release
Distribution Unlimited

Technical Information Division, ORE, Oak Ridge, Tennessee
AEC, Oak Ridge, Tenn., 2-8-50--850-A9326

Printed in U.S.A.
~~PRICE 10 CENTS~~

19961226 164

21-15222

CALIBRATION OF PHILIPS ION GAUGE

By J. R. Tolmie

Previously issued Vac. Special Reports No. 18 and 19, dealing with the Philips-type ion gauges, do not contain calibration curves of the gauges now in actual use, for no particular unit had been agreed upon as a standard at that time. This report accompanies a set of calibration curves of the standard gauge.

The calibration data shown on the accompanying charts were obtained by employing an experimental layout as indicated in schematic drawing No. X-1147. Both of the Philips ion gauges were of the conventional type. (See accompanying photographs.) These gauges are comprised of a 1-in. diameter ring type of anode, which is located coplanar with and midway between 2 2-1/2 in. square copper cathodes, which are separated by an interval of 1/2 in. The D. P. I. triode type of ionization gauge, which was employed during the tests, was in turn very carefully calibrated against a number of D. P. I. and Western Electric Company ionization gauges.

In the pressure range of 0.2×10^{-4} to 5×10^{-4} mm Hg, the glow discharge current of the Philips gauge is a substantially linear function of the pressure. Above this range, namely, in the region of 5×10^{-4} to 20×10^{-4} , an appreciable curvature becomes manifest. This curvature is not enough to be serious where only moderate accuracy is desired. These relations are shown on the following charts.

Chart No.	Effective pressure range, $\times 10^{-4}$ mm Hg
X-1148	0.2 — 1.0
X-1149	1.0 — 5.0
X-1150	0 — 20

Good correlation was obtained with the data, which were taken on successive days of the test. This is an indication of the stability of the gauge.

Charts No. X-1151 and X-1152 give a comparison between two ordinary shop models of Philips ion gauges. Taken one against the other these gauges show an excellent linear response. This linearity is also constant with time, as is indicated by the distribution of the observed data taken on successive days. Subsequent inspection showed that the anode ring in gauge No. 2 departed appreciably from its normal central position.

Charts No. X-1153 and X-1154, showing the volt-ampere and ampere-oersted characteristics of the Philips gauge, are submitted merely as supplementary information. Over the ranges shown the volt-ampere characteristics are linear and are reproducible from one gauge to another. The principal significance of the ampere-oersted characteristics lies in the fact that they appear to be substantially flat in the field region within which it is desired to operate the gauge.

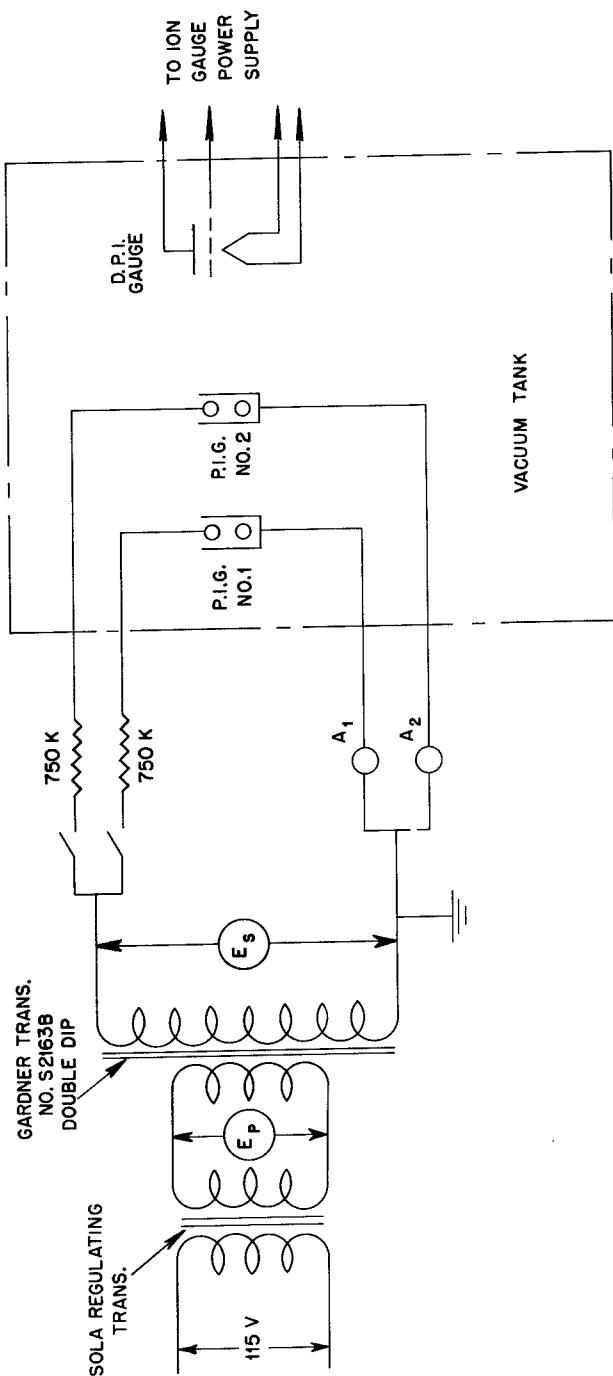

Schematic Diagram No. X-1147 — Philips ion gauge calibration layout.

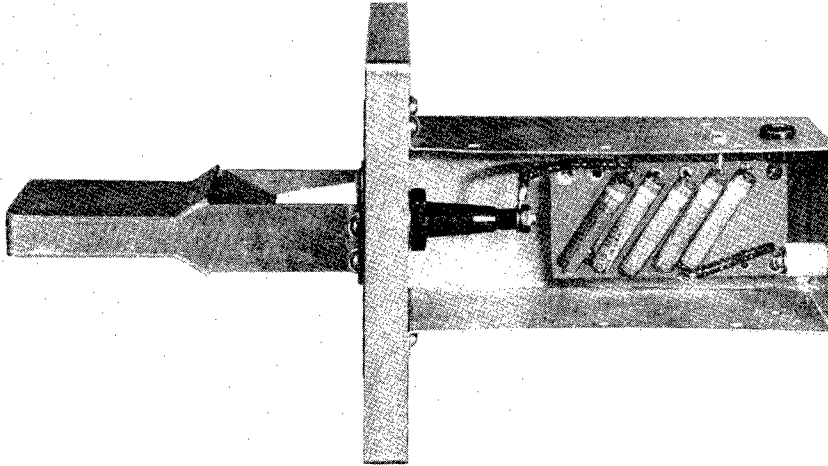

Spec. 259--A standard Philips ion gauge mounted on a small E window plate. Notice the isolantite sleeve protecting the B. G. mica spark plug. The cover for the ballast resistor box is not shown in this picture.

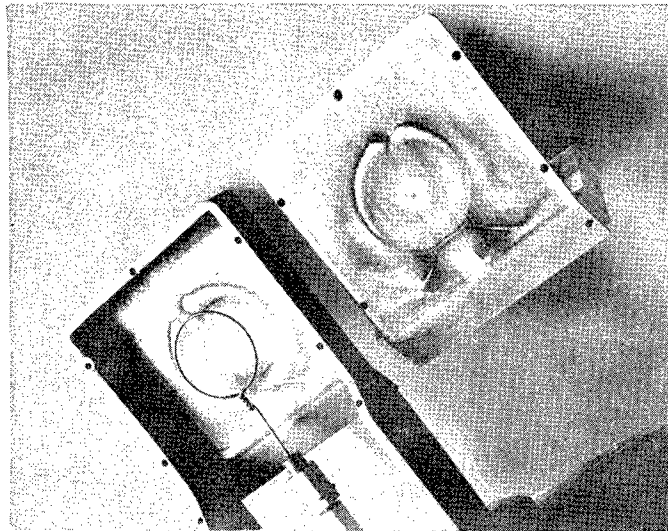

Spec. 261--A view of the gauge with one of the copper cathode plates removed. The markings on the copper surfaces are caused by the discharge.

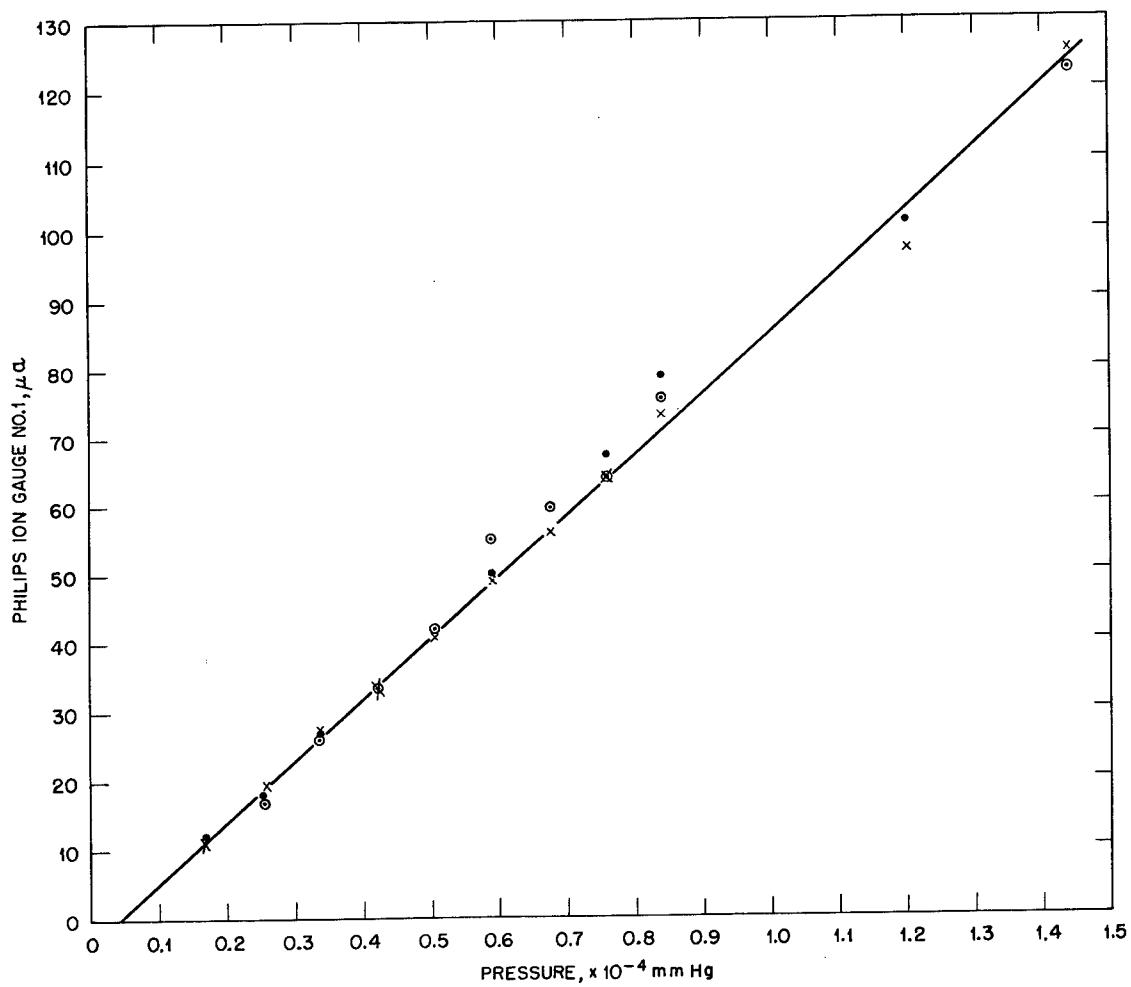

Chart No. X-1148--Philips ion gauge characteristic, range 1. Secondary E \approx 2050 v. Primary E=115 v. H=3350 oersteds. Data taken: ⊗⊗⊗⊗, 3-17-44; xxxx, 3-18-44;, 3-21-44.

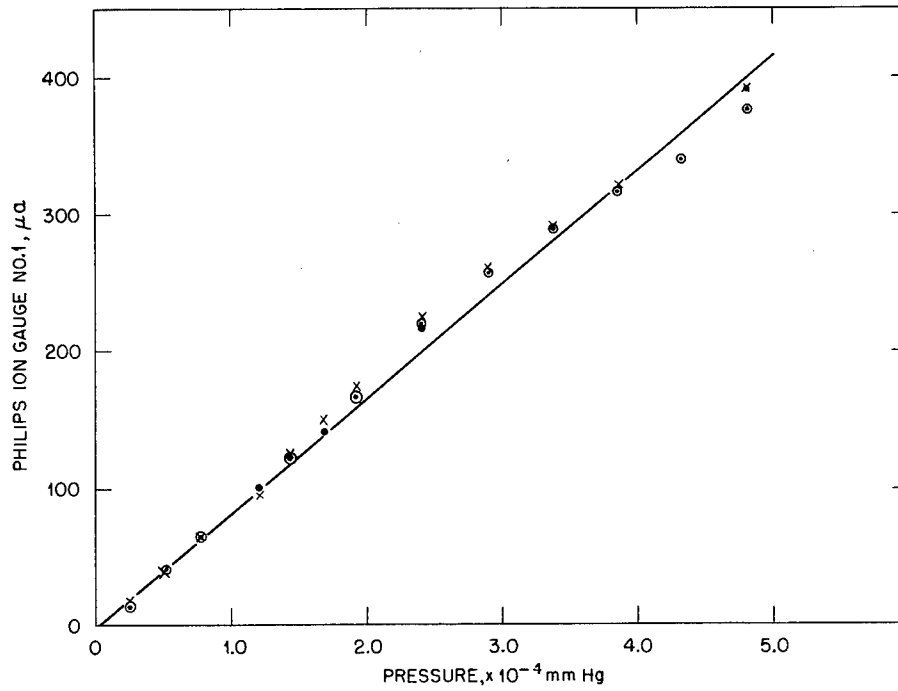

Chart No. X-1149--Philips ion gauge characteristic, range 2. Secondary E ≈ 2050 v. Primary E=115 v. H=3350 oersteds. Data taken: ○○○○, 3-17-44; xxxx, 3-18-44;, 3-21-44.

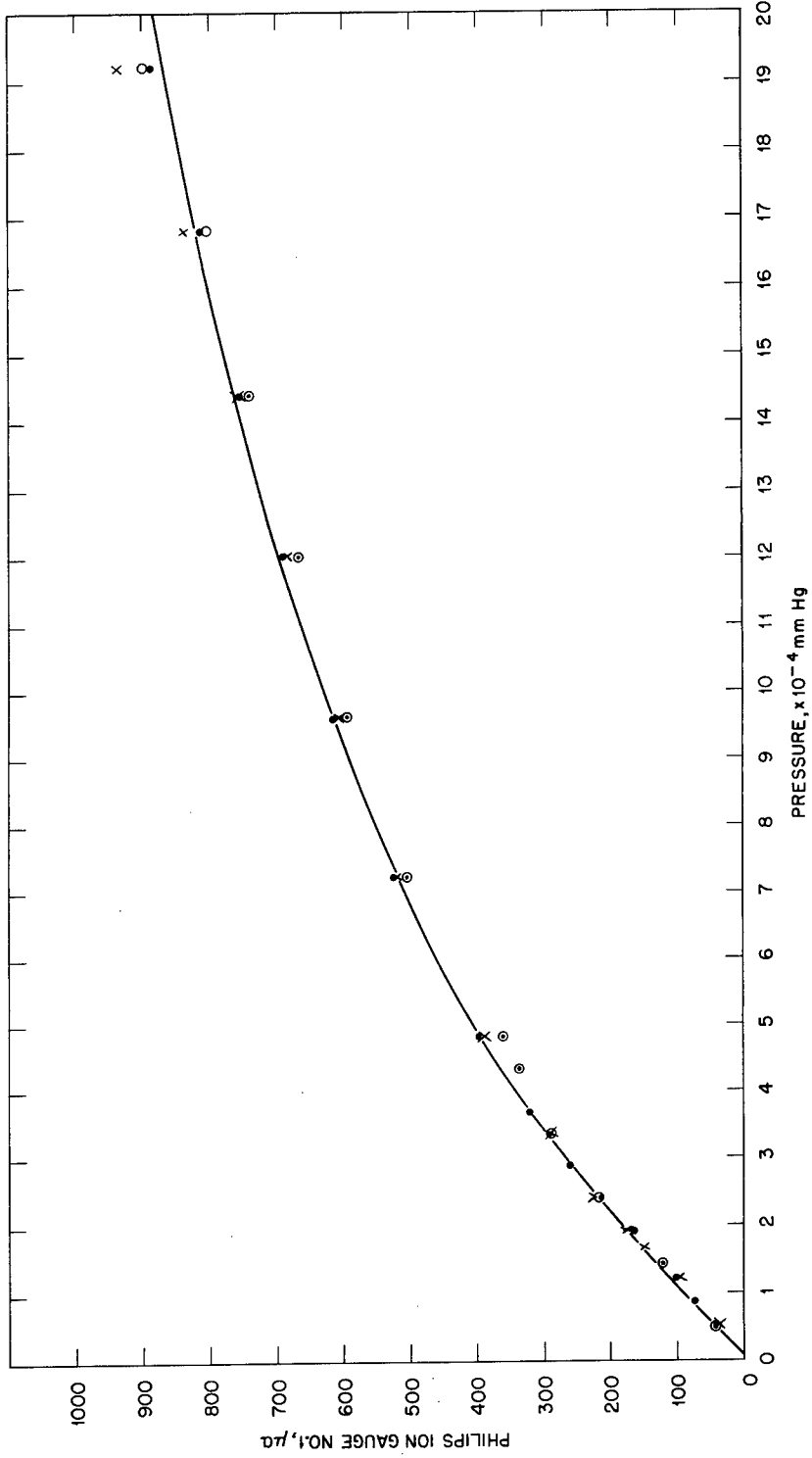

Chart No. X-1150--Philips ion gauge characteristic, range 3. Secondary E \approx 2050 v. Primary E=115 v. H=3350 oersteds. Data taken: $\odot\odot\odot\odot$, 3-17-44; $\times\times\times$, 3-18-44; \dots , 3-21-44.

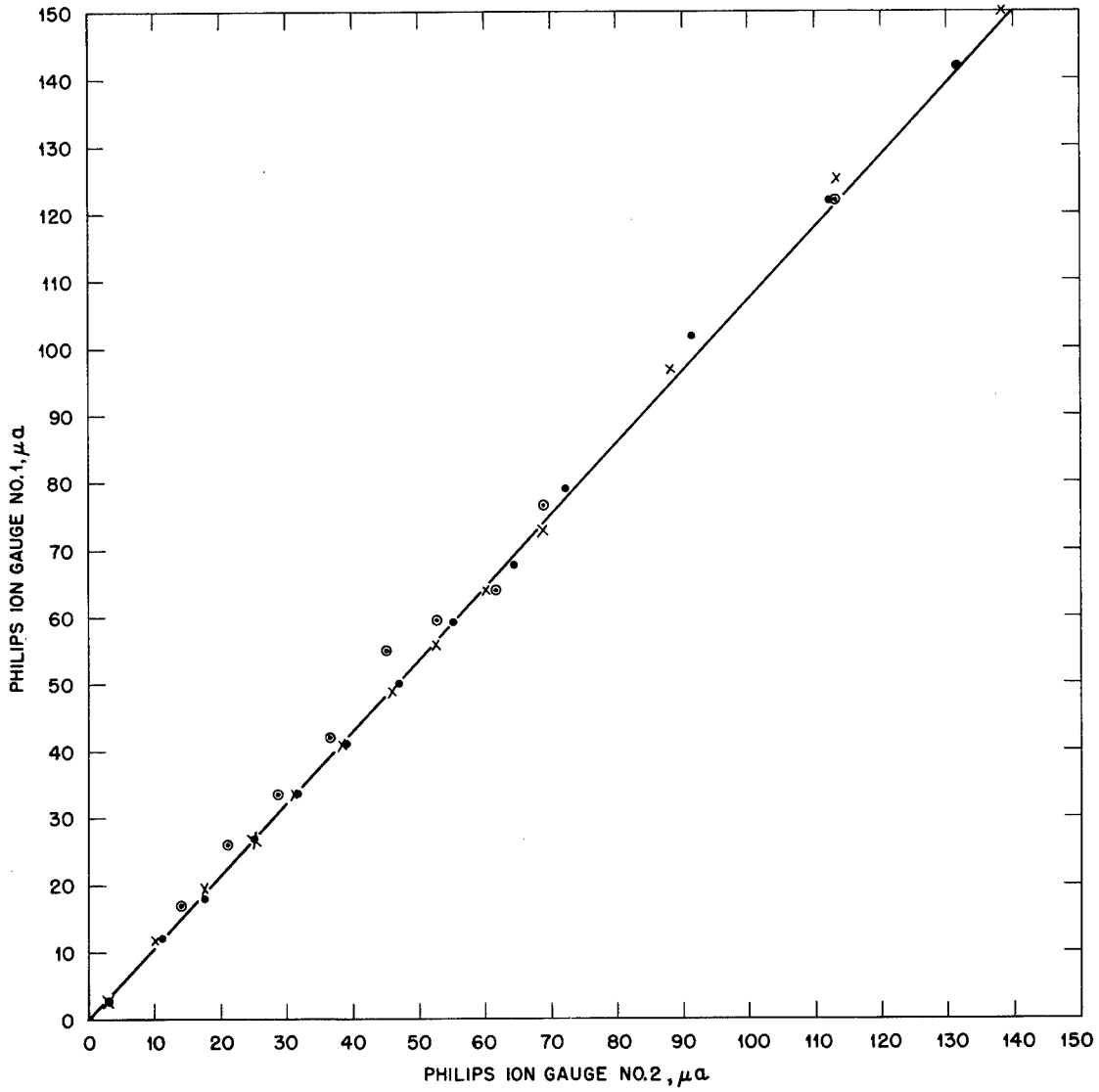

Chart No. X-1151--Comparison of Philips ion gauges, low range. Secondary $E \approx 2050$ v. Primary $E=115$ v. $H=3350$ oersteds. Data taken: ○○○○, 3-17-44; xxxx, 3-18-44;, 3-21-44.

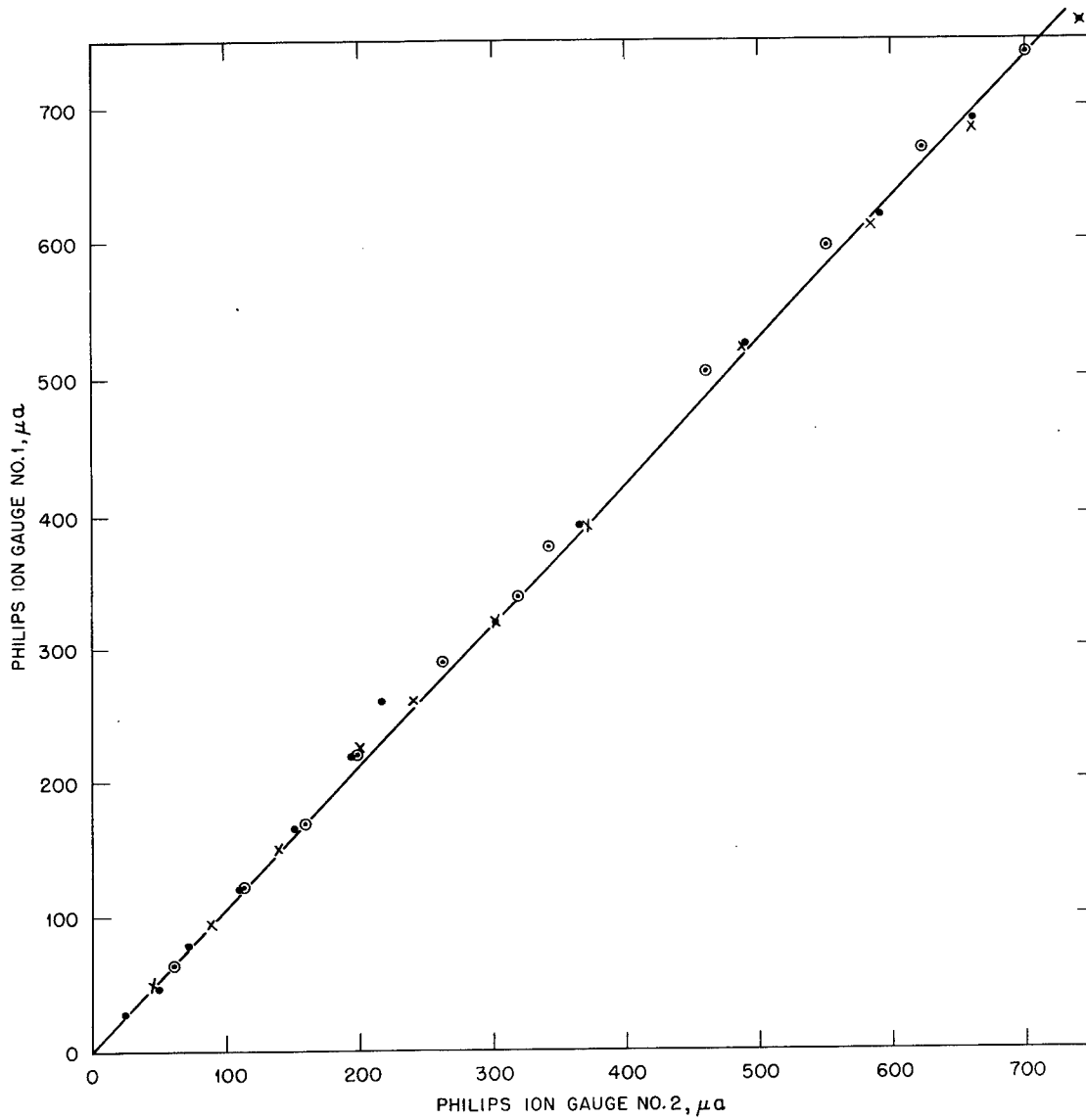

Chart No. X-1152--Comparison of Philips ion gauges, high range. Secondary E \approx 2050 v. Primary E=115 v. H=3350 oersteds. Data taken: $\circ\circ\circ\circ$, 3-17-44; $\times\times\times\times$, 3-18-44; \dots , 3-21-44.

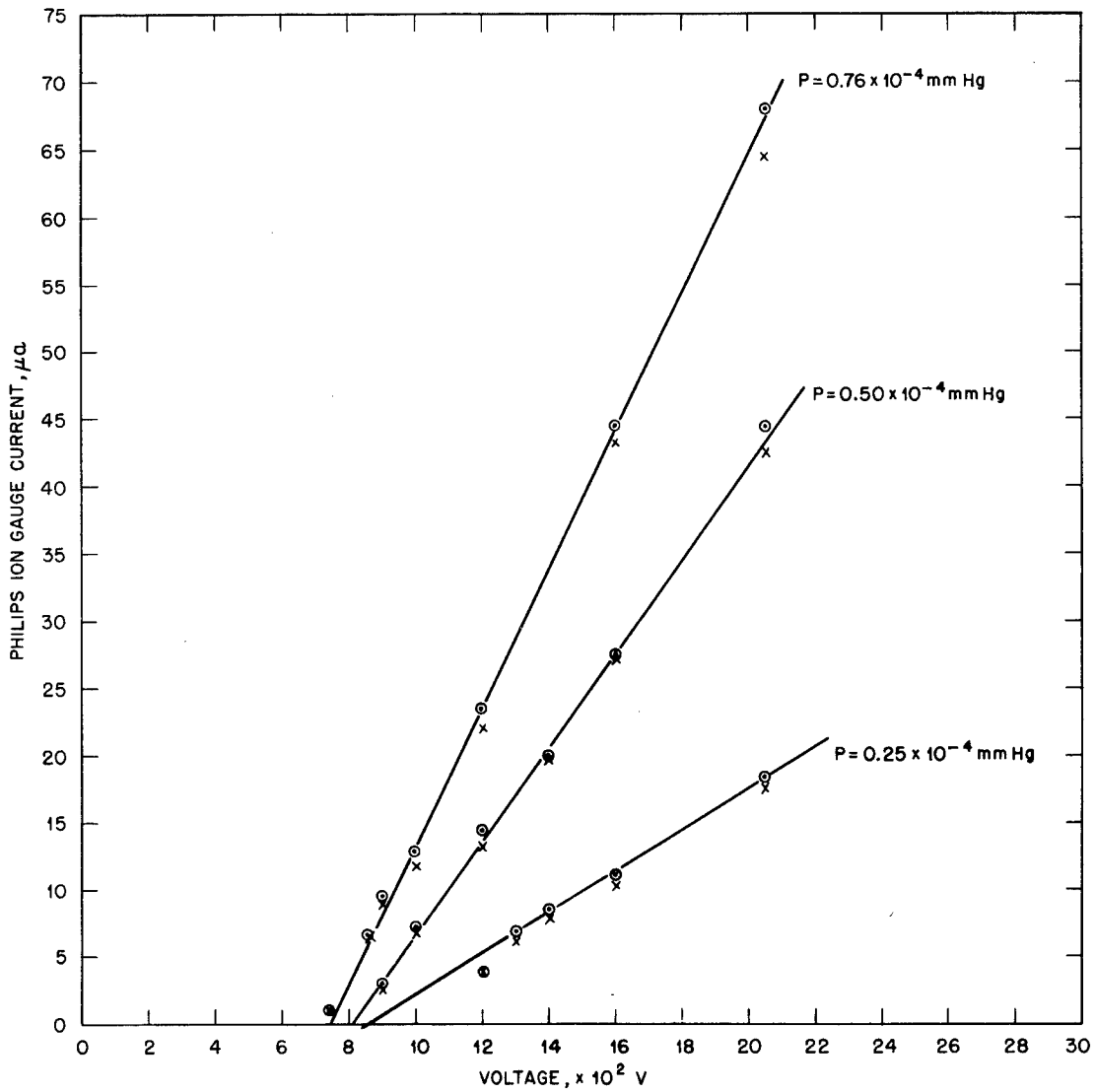

Chart No. X-1153--Philips ion gauge volt-ampere characteristic. H=3350 oersteds. $\circ\circ\circ\circ$, gauge No. 1. $\times\times\times\times$, gauge No. 2.

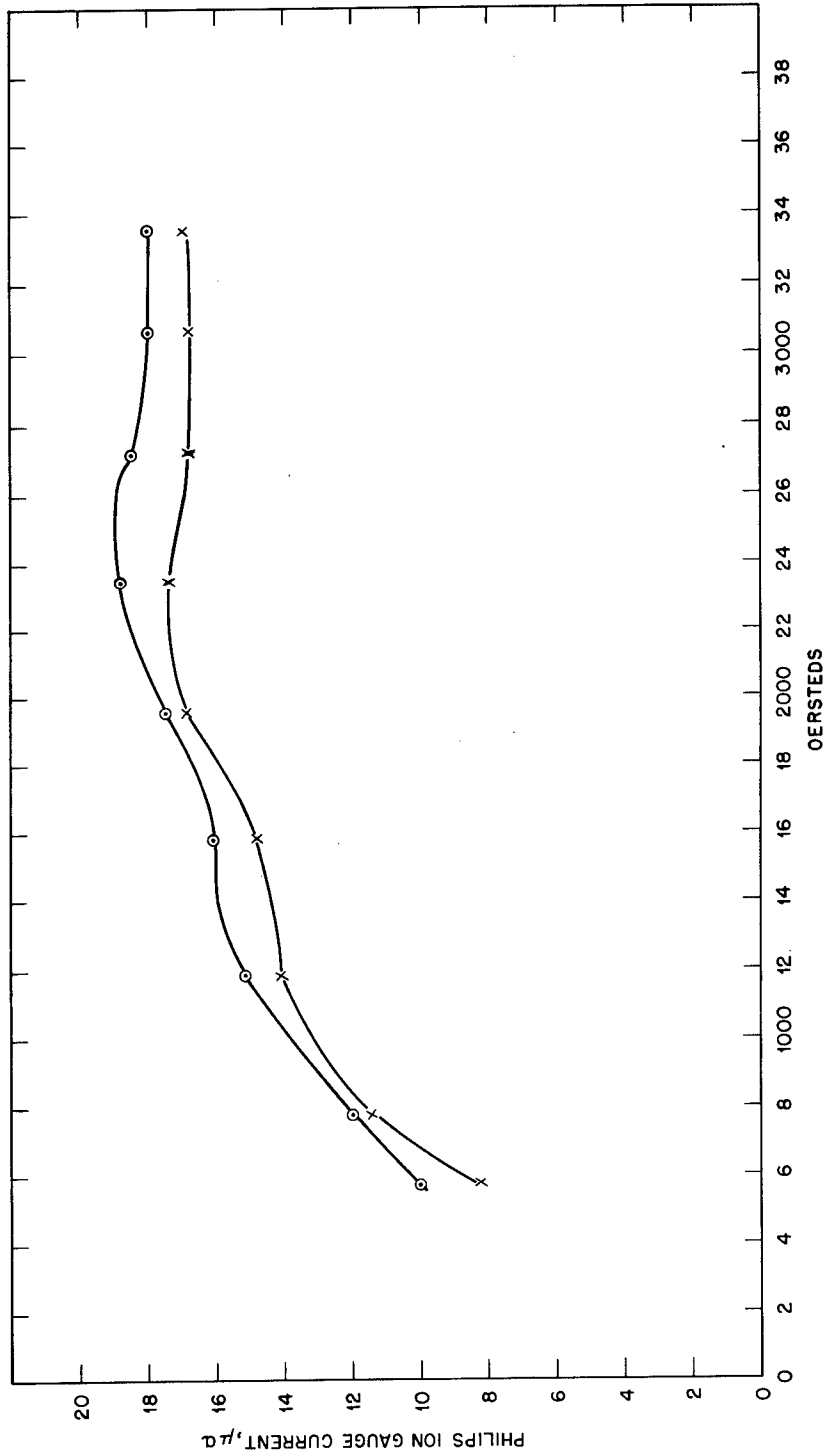

Chart No. X-1154--Philips ion gauge ampere-oersted characteristic. Secondary E \approx 2050 v.
Primary E=115 v. P=0.25 x 10⁻⁴ mm Hg. \circ \circ \circ \circ \circ , gauge No. 1. xxx, gauge No. 2.