



NRL/MR/6180--96-7902

Evaluation of Damage Control Tactics and Equipment - Phase I, Baseline Tests

S.A. HILL AND J.L. SCHEFFY

Hughes Associates, Inc.
Baltimore, MD

C. CAMPBELL AND R. BREUX

George G. Sharp, Inc.
Alexandria, VA

CDR. H. KUZMA

Naval Sea Systems Command
Arlington, VA

F.W. WILLIAMS

Navy Technology for Safety and Survivability
Chemistry Division

DTIC QUALITY INSPECTED 2

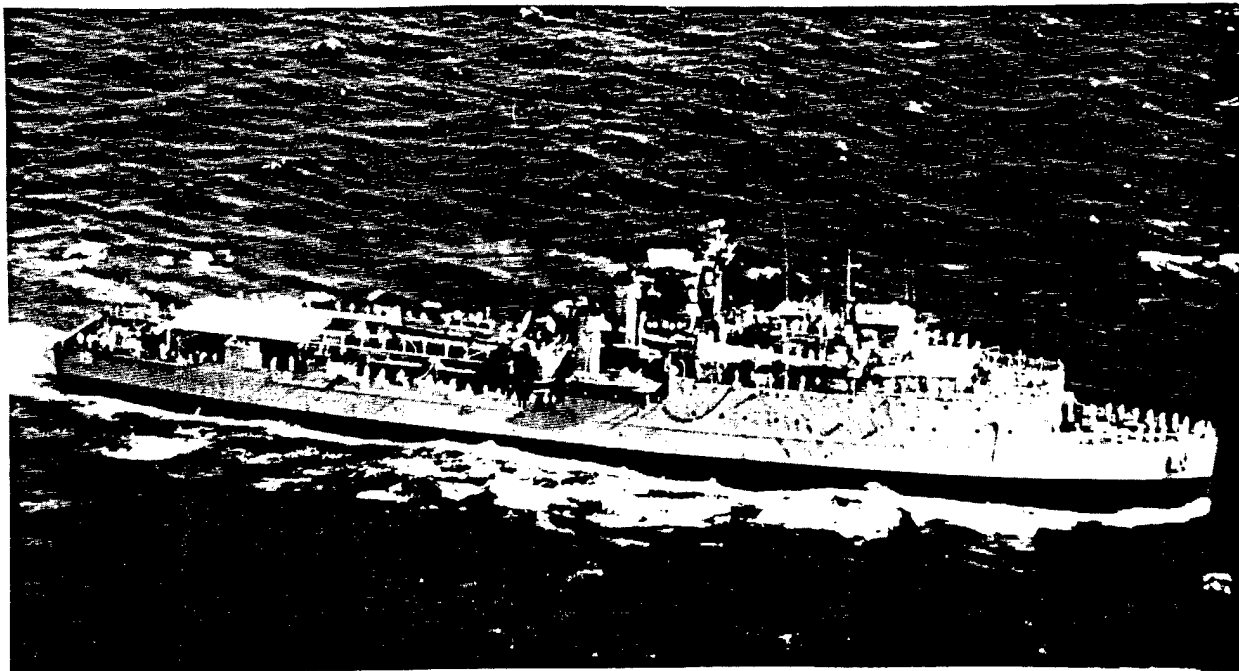

December 30, 1996

Approved for public release; distribution unlimited.

19970103 081

REPORT DOCUMENTATION PAGE

Form Approved
OMB No. 0704-0188

Public reporting burden for this collection of information is estimated to average 1 hour per response, including the time for reviewing instructions, searching existing data sources, gathering and maintaining the data needed, and completing and reviewing the collection of information. Send comments regarding this burden estimate or any other aspect of this collection of information, including suggestions for reducing this burden, to Washington Headquarters Services, Directorate for Information Operations and Reports, 1215 Jefferson Davis Highway, Suite 1204, Arlington, VA 22202-4302, and to the Office of Management and Budget, Paperwork Reduction Project (0704-0188), Washington, DC 20503.

1. AGENCY USE ONLY (<i>Leave Blank</i>)	2. REPORT DATE December 30, 1996	3. REPORT TYPE AND DATES COVERED Phase I — Test Series FY 1995	
4. TITLE AND SUBTITLE Evaluation of Damage Control Tactics and Equipment—Phase I, Baseline Tests		5. FUNDING NUMBERS	
6. AUTHOR(S) F.W. Williams, CDR H. Kuzma,* C. Campbell,** R. Breaux,** S.A. Hill,*** and J.L. Scheffey		8. PERFORMING ORGANIZATION REPORT NUMBER NRL/MR/6180--96-7902	
7. PERFORMING ORGANIZATION NAME(S) AND ADDRESS(ES) Naval Research Laboratory Washington, DC 20375-5320		10. SPONSORING/MONITORING AGENCY REPORT NUMBER	
9. SPONSORING/MONITORING AGENCY NAME(S) AND ADDRESS(ES) Chief of Naval Operations, N86D Washington, DC 20350		11. SUPPLEMENTARY NOTES *Naval Sea Systems Command, Arlington VA **George G. Sharp, Inc., Alexandria VA ***Hughes Associates, Inc., Baltimore MD	
12a. DISTRIBUTION/AVAILABILITY STATEMENT Approved for public release; distribution unlimited.		12b. DISTRIBUTION CODE	
13. ABSTRACT (<i>Maximum 200 words</i>) Surface Ship Survivability, NWP 62-1 Series, and the Naval Ship Technical Manual (NSTM) Chapter 079 Volume 2 are silent on tactics and procedures for attacking a combination flooding/fire incident. Repair and recovery from flooding incidents are often considered in isolation from a fire incident in fleet training tactics and doctrine. Yet, flooding may occur simultaneously with a fire incident. The emergency repair procedures/equipment evaluated in these tests included pipe patching, shoring, dewatering, and hull repair. All of the equipment used in these tests is currently available in the Damage Control Repair Station. With respect to pipe patching, the Jubilee patch was effective on pressurized systems whereas the banding kit proved to be ineffective on all of the pressurized systems. There appears to be little difference in the time to construct an I-shore, whether it is made of wood only or a combination of metal and wood. However, there is a substantial difference, nearly a factor of two, in the amount of time required to construct an all wood K-shore compared to the time to construct a wood and metal K-shore. Although the rigging time for the various pieces of dewatering equipment are similar, there are substantial differences in the total time required to begin dewatering and the dewatering rate. With respect to hull repair, the bucket patch was substantially easier and quicker to install than the plugs and wedges. The bucket patch was much more effective.			
14. SUBJECT TERMS ex-USS SHADWELL Shoring Damage control		Flooding Pipe-patching Dewatering	15. NUMBER OF PAGES 63
17. SECURITY CLASSIFICATION OF REPORT UNCLASSIFIED		18. SECURITY CLASSIFICATION OF THIS PAGE UNCLASSIFIED	16. PRICE CODE
19. SECURITY CLASSIFICATION OF ABSTRACT UNCLASSIFIED		20. LIMITATION OF ABSTRACT UL	

CONTENTS

	Page
1.0 INTRODUCTION	1
2.0 OBJECTIVE	1
3.0 DAMAGE CONTROL EQUIPMENT ALLOWANCES	2
3.1 Shoring	2
3.2 Pipe Patching	2
3.3 Dewatering	2
3.4 Hull Repair	2
4.0 TEST SETUP	2
4.1 Test Compartments	2
4.1.1 Fan Room	2
4.1.2 Upper Wet Compartment	6
4.1.3 Lower Wet Compartment	6
4.2 Damage	6
4.2.1 Pipe Damage	6
4.2.2 Shoring Damage	7
4.2.3 Dewatering	7
4.2.4 Hull Repair	7
5.0 INSTRUMENTATION	7
5.1 Temperature	7
5.2 Flow Rate	8
5.3 Pressure	8
5.4 Water Level	8
5.5 Observers	8
6.0 EXPERIMENTAL DESIGN AND TEST PROCEDURE	8
6.1 Test Matrix	8
6.2 Pipe Patching Procedures	9
6.2.1 Jubilee Patch Repair Procedures	9
6.2.2 Banding Kit with Chain Wrench Repair Procedure	9
6.3 Shoring Procedures	9
6.3.1 Wooden I-shore	12
6.3.2 Wood/Metal Combination I-shore	12
6.3.3 Wooden K-shore	12
6.3.4 Wood/Metal Combination K-shore	12
6.4 Dewatering Procedures	16
6.4.1 P-250/P-100 with Foot Valve Dewatering Procedures	16
6.4.2 P-250/P-100 with 38.1 mm (1.5 in.) Eductor Dewatering Procedures	16
6.4.3 Electrical Submersible Dewatering Procedures	16

CONTENTS (Continued)

	Page
6.5 Hull Repair Procedures	16
6.5.1 Bucket/Box Patch Repair Procedures	16
6.5.2 Plugs and Wedges Repair Procedures	20
7.0 RESULTS AND DISCUSSION	20
7.1 Pipe Patching	22
7.2 Shoring	24
7.3 Dewatering	26
7.4 Hull Repair	28
7.5 Analysis	28
8.0 CONCLUSIONS	28
9.0 RECOMMENDATIONS	30
10.0 ACKNOWLEDGMENT	30
11.0 REFERENCES	31
Appendix A - Instrumentation Drawings	A-1
Appendix B - Instrumentation Listing	B-1
Appendix C - Original Test Schedule	C-1
Appendix D - Actual Test Schedule	D-1

FIGURES

	Page
Figure 1. Fan room layout	3
Figure 2. Upper wet compartment layout	4
Figure 3. Lower wet compartment layout	5
Figure 4. Jubilee pipe patch	10
Figure 5. Banding kit with chain wrench pipe patch	11
Figure 6. I-type shoring	13
Figure 7. Wooden K-type shoring	14
Figure 8. Wood/metal combination K-shore	15
Figure 9. P250/P100 pump configurations for suction lifts under 6.1 m (20 ft)	17
Figure 10. Electrical submersible pump configuration	18
Figure 11. Box patch hull repair	19
Figure 12. Plugs and wedges hull repair	21

TABLES

	Page
Table 1. Summary of Effectiveness Criteria	20
Table 2. Summary of Pipe Patching Tests	23
Table 3. Summary of Shoring Tests	25
Table 4. Summary of Dewatering Tests	27
Table 5. Summary of Hull Repair Tests	29

Evaluation of Damage Control Tactics and Equipment - Phase I, Baseline Tests

1.0 INTRODUCTION

Research and development to address damage control tactics, techniques, and procedures were initiated by the Naval Sea Systems Command (NAVSEA) and the Naval Research Laboratory (NRL). This research was aimed at improving the following areas: integrated damage control tactics and techniques, equipment, and secondary damage modeling.

Surface Ship Survivability, NWP 62-1 Series [1], and the Naval Ship Technical Manual (NSTM) Chapter 079 Volume 2 [2] are silent on tactics and procedures for attacking a combination flooding/fire incident. Repair and recovery from flooding incidents are often considered in isolation from a fire incident in fleet training tactics and doctrine. Yet, flooding may occur simultaneously with a fire incident, e.g., due to collision, grounding, or detonation of a weapon. The damage control tests will ultimately provide an opportunity to integrate a simultaneous flooding and fire casualty.

The test series discussed in this report is the first of two test series intended to provide baseline data from which new tactics and equipment can be compared. The repair activities evaluated in these tests included pipe patching, shoring, dewatering, and hull repair. All of the equipment used in these tests is currently available in the Damage Control Repair Station.

The port wing wall of the ex-USS SHADWELL, NRL's full-scale fire research platform [3], was used for this test series. The port wing wall has been modified to simulate a single flooded compartment. In the FY 96 test series, a second flooded compartment will be added to evaluate progressive flooding threats. These modifications are discussed in [4].

2.0 OBJECTIVE

The primary objective of the FY 95 testing is to develop the data necessary in quantifying individual functional damage control tactics and techniques, including equipment setup times, in uncontrolled flooding scenarios. These data can then be used to analyze repair party manning issues and damage control tactics and procedures. New personnel protective equipment can also be evaluated.

In the initial test series, shoring, dewatering, pipe patching, and hull repair techniques were evaluated. The shoring tests examined the use of wood and wood/metal combinations in constructing I and K shores. The dewatering tests included three pumps: (1) P-100, (2) P-250, and (3) electrical submersible. The pipe patching tests evaluated the repair of pressurized lines using the pipe wrench with the banding kit and the Jubilee patch. Tests were conducted using a variety of pipe sizes and pipe ruptures. The hull repair tests focused on the use of the bucket patch and the plugs and wedges approach to repairing explosion and implosion ruptures.

Concurrent with the testing, the test platform was prepared for advanced damage control concepts and for the introduction of integrated damage control tests. It is anticipated that the Integrated Casualty Response and Recovery (ICR²) program will validate these concepts.

3.0 DAMAGE CONTROL EQUIPMENT ALLOWANCES

3.1 Shoring

The shoring equipment used was typical of the equipment available in a shipboard repair station. Two types of shores were evaluated: (1) all wood and (2) wood and steel. The steel shoring was used in conjunction with wood shoring to demonstrate the ease of erecting and time needed to position the combination shore.

3.2 Pipe Patching

Pipe patching equipment used in this test series included onboard allowances as well as the chain wrench. The chain wrench, currently available to submarine damage control teams, is being included in the Damage Control Allowance for surface ships this year.

3.3 Dewatering

Five different dewatering equipment configurations were evaluated during this test series, including (1) P-100 with an 38 mm (1.5 in.) eductor, (2) P-100 with a foot valve, (3) P-250 with 64 mm (2.5 in.) eductor, (4) P-250 with a foot valve, and (5) electric submersible pump. Each of the P-100 and P-250 pump configurations included a strainer.

3.4 Hull Repair

Hull repairs were accomplished using equipment currently available in the repair locker. However, only the bucket patch and wood plugging kits were utilized. Future test series will evaluate the plate repair and the use of shoring in conjunction with a patch to stop flooding.

4.0 TEST SETUP

4.1 Test Compartments

The port wing wall of the ex-USS SHADWELL was used for the Damage Control testing. The areas between FR 88 and 95 of the first, second, and third decks were the primary test areas. These areas are referred to as the Fan Room, Upper Wet Compartment, and Lower Wet Compartment, respectively. The layouts for these compartments are shown in Figures 1, 2 and 3. The Figures contained in Appendix A show the instrumentation layout and damage locations for each of the compartments.

4.1.1 Fan Room

The Fan Room, shown in Figure 1, provided access to the Upper Wet Compartment via a watertight hatch (WTH 1-89-2). Each of the repair parties entered the Upper Wet Compartment through this hatch. The dewatering teams also used a scuttle (QAS 1-93-2), located inboard of the Fan Room at weather, to lower their equipment into the Upper Wet Compartment. In all cases, with the exception of the shoring team, the repair teams were staged immediately aft of the Fan Room prior to test initiation.

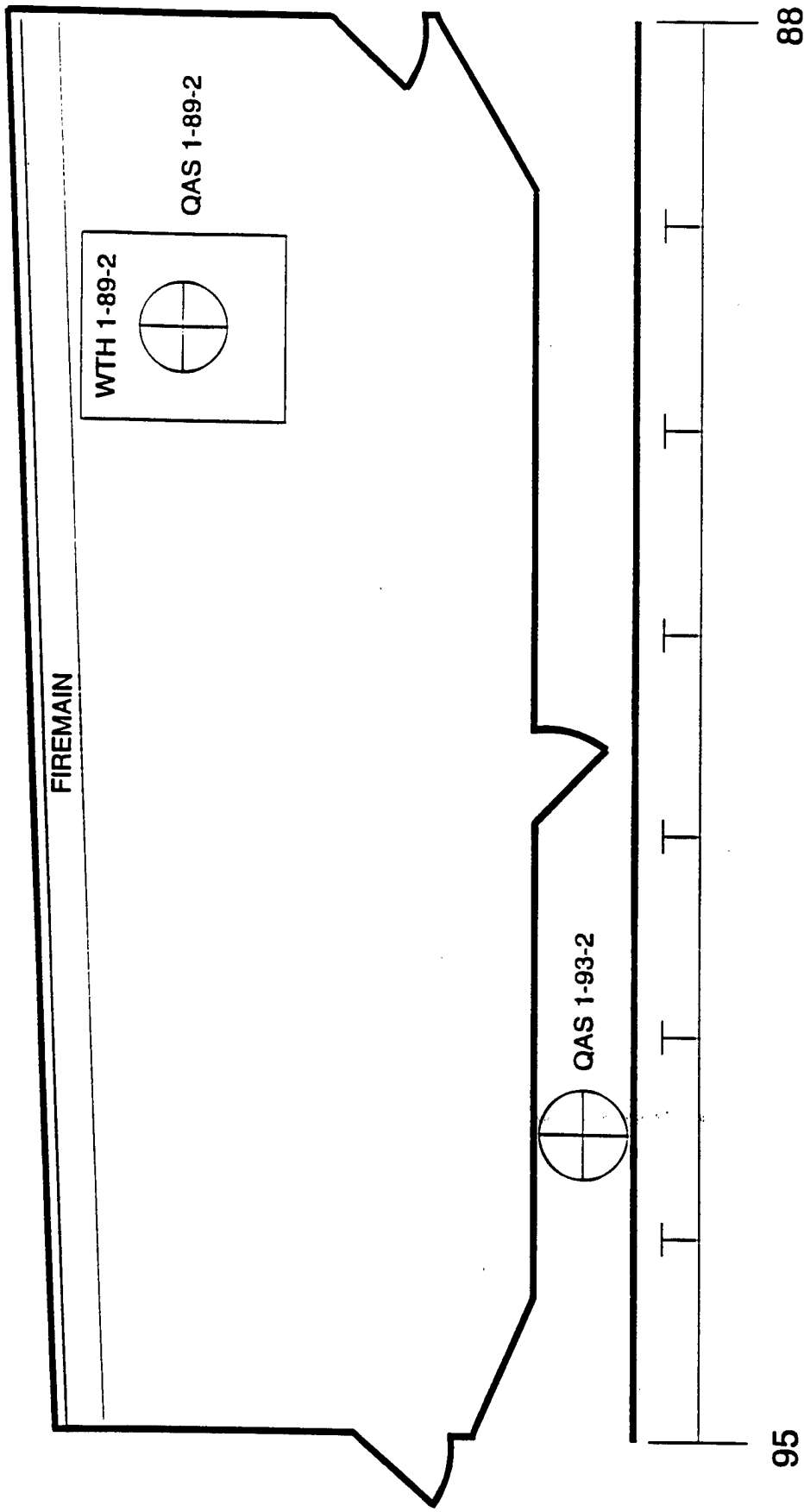

1ST PLATFORM	REV: 7/6/95
FILE: SUB1-95	DATE: 4/19/94

Fig. 1 – Fan room layout

FM RISER
2-88-4

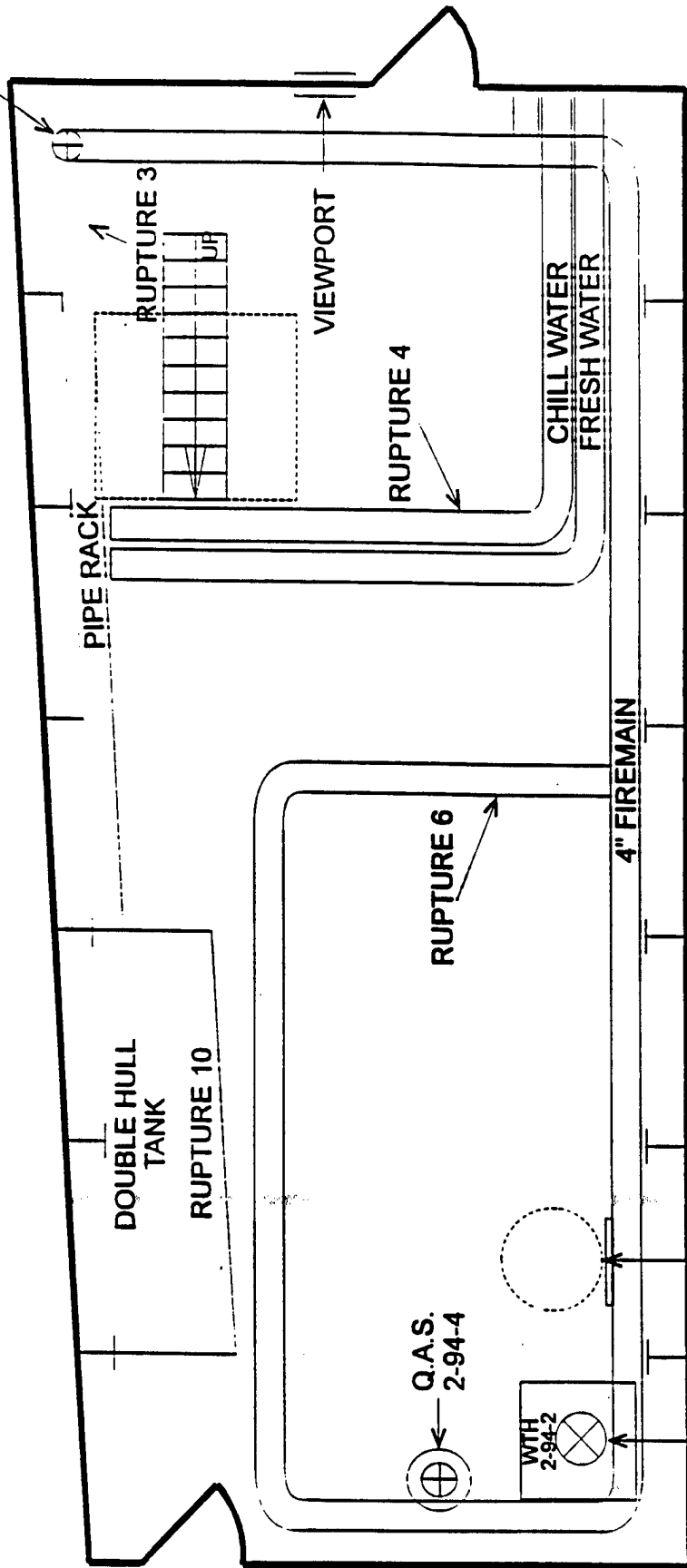

88

2ND PLATFORM	REV: 7/6/95
FILE: SUB2-95	DATE: 4/19/94

Q.A.S.
1-93-2

Q.A.S.
2-94-2

95

Fig. 2 - Upper wet compartment layout

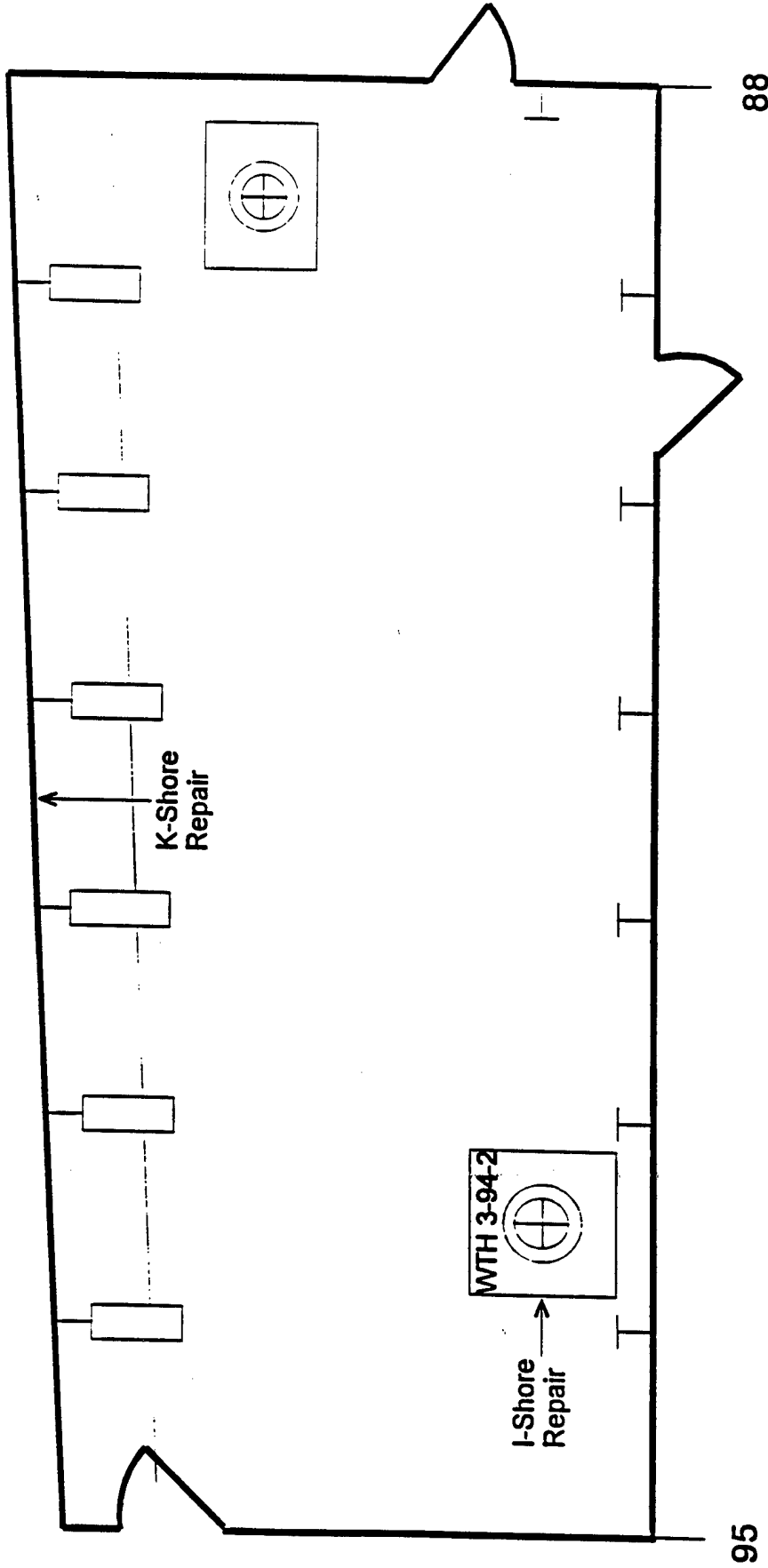

3RD PLATFORM	REV: 7/5/95
FILE: SUB3-95	DATE: 4/19/94

Fig. 3 - Lower wet compartment layout

4.1.2 Upper Wet Compartment

The Upper Wet Compartment, shown in Figure 2, contained three separate water lines: firemain, chill water, and fresh water. The fresh water line, which consisted of copper/nickel (90/10) pipe with an outside diameter of 60.3 mm (2.4 in.) and a wall thickness of 2.1 mm (0.08 in.), was not used during this test series. The chill water line consisted of copper/nickel (90/10) pipe with an outside diameter of 60.3 mm (2.4 in.) and a wall thickness of 2.1 mm (0.08 in.). This line entered the compartment along the inboard bulkhead at FR 88 and ran aft to FR 90. At FR 90, the chill water line turned and ran to the outboard bulkhead, where the line terminated. The chill water line was supplied by a single pump, a 1325 Lpm (350 gpm) portable electric pump, connected to the chill water line at 2-88-2. A pressure reducing valve maintained a static pressure of 3.8 bar (55 psi) in the chill water line.

The firemain consisted of a loop between FR 91 and FR 95. A line branched off of this loop on the inboard side of the compartment at FR 91. This branch line extended to FR 88, where it turned and extended to the outboard bulkhead. All of the pipe was copper-nickel (90/10) with an outside diameter of 88.9 mm (3.5 in.) and a wall thickness of 2.4 mm (0.095 in.).

The firemain was supplied by three pumps. The first pump, a 1325 Lpm (350 gpm) portable electric pump, was connected into the ship's firemain on the starboard wing wall. This pump was intended to boost the pressure and flow provided by the installed 1325 Lpm (350 gpm) pump. The third pump, a 1325 Lpm (350 gpm), gas-powered Godiva pump, supplied the firemain via the connection at 2-88-2. This pump was used as a secondary water source, in case one of the other two pumps failed. These pumps maintained a static pressure of approximately 7.6 bar (110 psi).

4.1.3 Lower Wet Compartment

The Lower Wet Compartment, shown in Figure 3, was used only for the shoring tests during this test series. In future test series, this compartment will be used in cascading flooding scenarios.

4.2 **Damage**

As discussed previously, all of the pipe and hull damages for this test series were contained in the Upper Wet Compartment. All of the shoring tests were conducted in the Lower Wet Compartment.

4.2.1 Pipe Damage

A total of four separate pipe ruptures, shown in Figure 2, were used during this test series. All of the ruptures were on pressurized systems. A pressurized system or non-isolated system is a system where the flow of water to the rupture cannot be secured. An isolated system is a system where the flow of water to the rupture can be secured by closing control valves. Three of the ruptures were in the firemain and the fourth was in the chill water line. The chill water rupture (Rupture 4) was a split seam rupture, measuring 152 mm x 13 mm (6 in. x 0.5 in.), located at 2-90-2. A pressure reducing valve maintained a static pressure of 3.8 bar (55 psi) in the chill water line. This rupture flowed approximately 49 Lpm (13 gpm) and had a nominal residual pressure of zero.

Two of the three firemain ruptures were located in a pipe mockup (Rupture 3). The pipe mockup was located between FR 88 and FR 89 along the outboard bulkhead. The static pressure in the firemain was approximately 7.6 bar (110 psi). The first pipe mockup rupture (Rupture 3, 3.5 in.) simulated compound damage with jagged edges. This rupture measured 44.4 mm (1.75 in.) by 38.1 mm (1.5 in.). This rupture flowed approximately 568 Lpm (150 gpm) and had a residual pressure of 1.4 bar (20 psi).

The second pipe mockup rupture (Rupture 3, 2.4 in.) simulated a split seam. This rupture measured 69.8 mm (2.75 in.) by 6.3 mm (0.25 in.) and flowed approximately 568 Lpm (150 gpm) at a residual pressure of 1.4 bar (20 psi). The third firemain rupture (Rupture 6) was located at 2-91-2 in the firemain loop. This rupture measured 101.6 mm (4.0 in.) by 38.1 mm (1.5 in.) and simulated simple compound damage with jagged edges. With a residual pressure of 1.7 bar (25 psi) this rupture flowed 590 Lpm (156 gpm).

4.2.2 Shoring Damage

The shoring team was responsible for performing two types of shores. The first shore was an I-shore on WTH 3-94-2. This hatch provided access between the Lower Wet Compartment and the Bilge. The second shore was a K-shore supporting the outboard bulkhead at 3-92-2.

4.2.3 Dewatering

All of the dewatering tests used the same damage scenario. The Upper Wet Compartment was filled with water to an initial depth of approximately 610 mm (24 in.). The dewatering tests were continued for a minimum of 20 minutes (dewatering time) to obtain a steady dewatering rate.

4.2.4 Hull Repair

Two types of hull ruptures were used during this test series. Both of the hull ruptures, shown in Figure A-7 as Rupture 10, were supplied by water contained in the double hull (storage) and pilot house tanks. The hull ruptures were supplied directly by the double hull tank. Water contained in the pilot house, located above the storage tank, supplied the storage tank with additional water. The first rupture was intended to simulate an explosion rupture. This rupture consisted of a single circular hole with a diameter of approximately 178 mm (7 in.). Initially, the rupture flowed 11239 Lpm (2969 gpm) and 5190 Lpm (1371 gpm) after three minutes of unobstructed flow (i.e. no repair in progress). After 4 minutes of unobstructed flow the water in the tank was at equilibrium with the water in the Upper Wet Compartment. The second rupture simulated an implosion rupture. This rupture consisted of a single circular hole with a diameter of approximately 100 mm (4 in.). Initially, the rupture flowed 4876 Lpm (1288 gpm) and 4281 Lpm (1131 gpm) after six minutes of unobstructed flow (i.e. no repair in progress).

5.0 INSTRUMENTATION

The test area was instrumented to provide pressure, flow rate, liquid level, and temperature measurements. The instrumentation is shown in the Figures contained in Appendix A. In addition, a complete description of all of the instrumentation, including video and audio, is provided in the channel listing contained in Appendix B.

5.1 Temperature

Temperature was measured with two thermocouple strings. The first thermocouple string, located at 2-94-2, consisted of seven type-K, inconel-sheathed thermocouples. The thermocouples were positioned at 0.3, 0.6, 0.9, 1.2, 1.5, 1.8, and 2.1 m (1.0, 2.0, 2.9, 3.9, 4.9, 5.8, and 6.8 ft) above the deck. The second thermocouple string was located at 3-93-0 and consisted of five type-K, inconel-sheathed thermocouples. These thermocouples were positioned at 0.5, 1.0, 1.5, 2.0, and 2.5 m (1.6, 3.2, 4.9, 6.5, 8.1 ft) above the deck. These provide ambient air temperature measurements and the capability to measure water temperature in the future cold water tests.

5.2 Flow Rate

Flow rate was measured to determine the effectiveness of the pipe repair activities. The firemain flow rate was measured using a Controlotron ultrasonic flowmeter. This flowmeter was located on the firemain at 1-79-4 and provided the flow rate for all of the firemain pipe rupture tests. The chill water flow rate was measured using a turbine flowmeter with a range of 0 to 852 Lpm (0 to 225 gpm). The turbine flowmeter was located at 2-88-2 on the chill water line.

5.3 Pressure

Pressure measurements were made to determine the effectiveness of the pipe repair activities. The firemain pressure was measured at three locations. The firemain pressure measurements at 1-79-2 along the port wing wall and at 1-75-1 along the starboard wing wall were made using Setra Model 207 pressure transducers with a range of 0 to 34.5 bar (0 to 500 psi). The firemain pressure was also measured at 2-88-4. This measurement was made using a Setra Model 207 pressure transducer with a range of 0 to 17.2 bar (0 to 250 psi). The chill water pressure was also measured at 2-88-2 with a Setra Model 207 pressure transducer with a range of 0 to 17.2 bar (0 to 250 psi).

The firemain and chill water pressures were also measured with fiberoptic pressure sensors. Both of these measurements were made at 2-88-2 and were recorded by the Damage Control Flooding Sensor Computer, operated by NSWC Annapolis, which will be the subject of a future report.

5.4 Water Level

Water level measurements were made using fiberoptic pressure sensors. These measurements were recorded by the Damage Control Flooding Sensor Computer, operated by NSWC Annapolis. The water levels in the pilot house, storage tank, upper wet space, and lower wet space were all recorded.

5.5 Observers

Each repair team was paired with an on-scene observer. The on-scene observer recorded the actual repair time as well as qualitative data. The observers made determinations of the effectiveness of the repair activity. This effectiveness was based on the effect of the repair on the damage, the repair technique as well as the time to complete the repair activity. The on-scene observers commented on equipment and items used and not used in each of the repair kits. They also made observations related to manpower requirements.

6.0 EXPERIMENTAL DESIGN AND TEST PROCEDURE

6.1 Test Matrix

The test matrix (Appendix C) was developed by Desmatics, Inc. to allow a reliable statistical analysis of the test data. The statistical test design was used to determine the effects of each test variable on the effectiveness of the repair and the effects of improved performance as a function of test repetition (i.e. "learning curve effects"). The matrix was designed to eliminate fatigue as a factor by providing adequate rest time for each of the repair teams between tests. Due to on-site considerations, the actual test schedule (Appendix D) deviated slightly from the proposed schedule. The only significant deviation in the test schedule was the switching of Day 2 tests with the Day 1 tests. Tests were combined to maximize the use of

the test period. It is important to note that the activities of one test did not interfere with those of another and, therefore, did not have any effects on the statistical analysis.

The tests were conducted May 18-24, 1995 aboard the ex-USS SHADWELL. Pipe patching and dewatering tests were conducted on each of the six test days. Shoring tests were performed the first three test days (May 18-20) and the hull repair tests were performed on the last three test days (May 22-24). Each of the repair teams consisted of crewmembers from the USS ENTERPRISE.

6.2 Pipe Patching Procedures

Pipe ruptures and damage in various water systems were repaired using either Jubilee patches or Banding kits with a chain wrench. All of the pipe repairs were performed in the Upper Wet Compartment (2-89-2-L). The Jubilee patches and Banding kits were used on the firemain and chill water systems.

6.2.1 Jubilee Patch Repair Procedures

The Jubilee patch, shown in Figure 4, consists of a gasket material and a light, flexible cylinder split on one side. The split incorporates flanges and bolt holes, which allow the cylinder to be closed. To effect the patch, the gasket material was wrapped around the pipe rupture. The cylinder was then placed around the gasket material with the bolt holes approximately 180 degrees from the rupture. With the patch in place, bolts were inserted through the flanges and tightened until the leak was stopped or significantly reduced.

6.2.2 Banding Kit with Chain Wrench Repair Procedure

The Banding kits, shown in Figure 5, consist of a gasket material, screen wire, pre-fabricated metal plates (strongbacks) for various sized pipes, a chain wrench, metal bands, and a banding tool. To effect this repair, the hole was covered with the gasket material, then the screen mesh, followed by the strongback. The chain wrench was then clamped in the center of the patch to hold it in place while the banding tool was used to secure bands on each end. Once the ends were banded, the chain wrench was removed and the patch was banded in the center. Additional bands were used to reduce the flow of water.

6.3 Shoring Procedures

Both "I" and "K" shoring procedures were employed using both wooden shoring alone and a combination of wood and metal shoring. All of the shoring tests were conducted in the Lower Wet Compartment (3-89-2-Q). The "I" shores were used to secure a warped deck hatch (WTH 3-94-2). The K-shores were used to strengthen and support a weakened structural bulkhead (outboard bulkhead at 3-92-2).

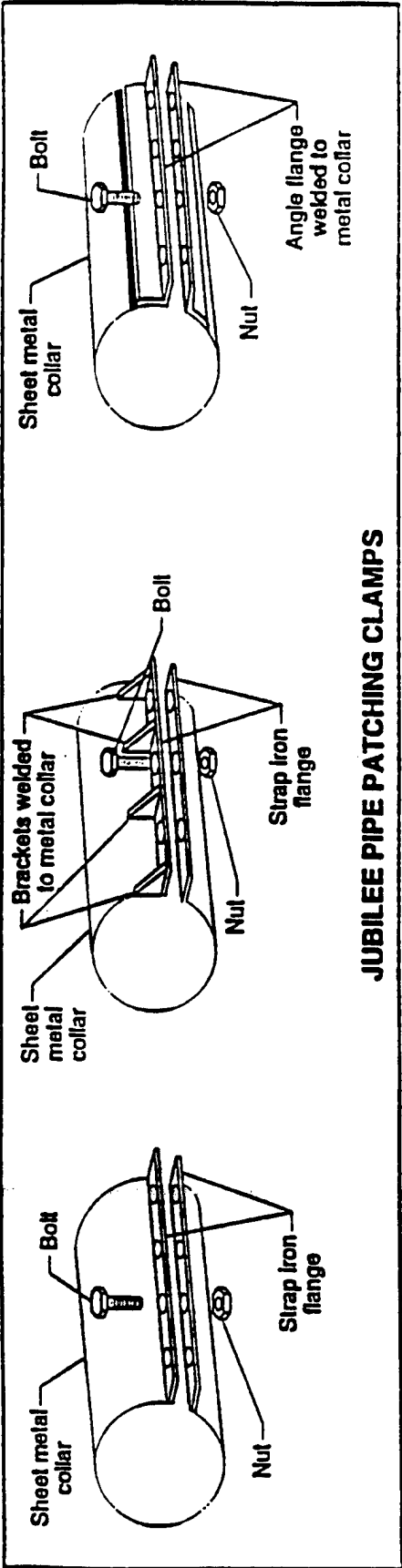

JUBILEE PIPE PATCHING CLAMPS

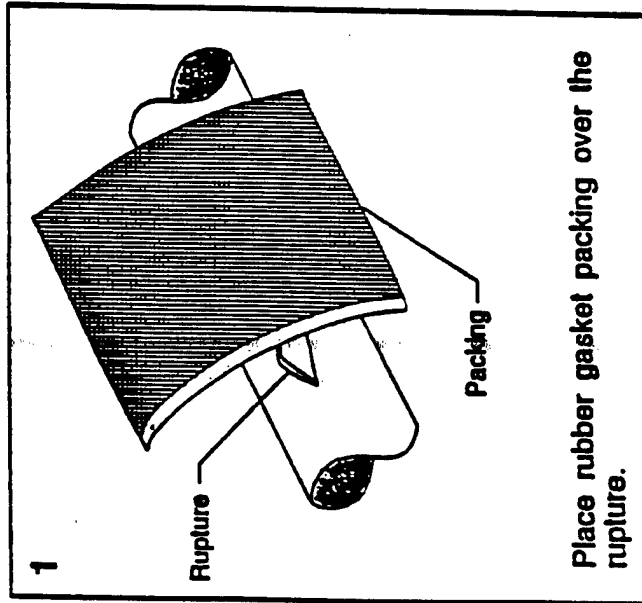

Place rubber gasket packing over the rupture.

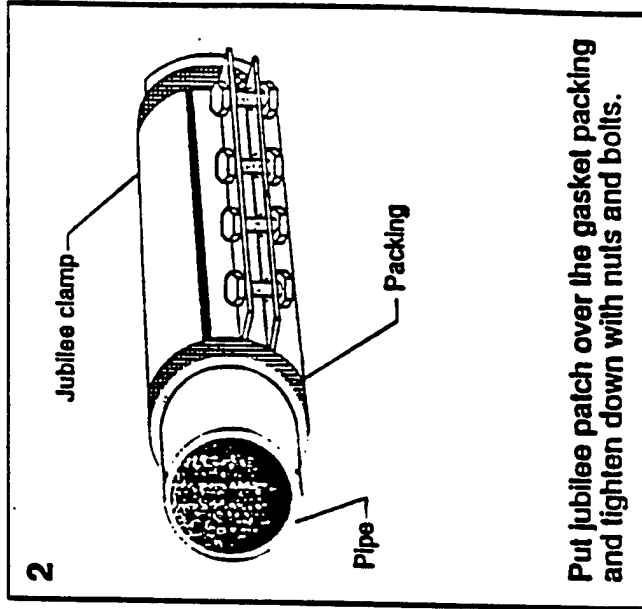

Put Jubilee patch over the gasket packing and tighten down with nuts and bolts.

Fig. 4 -- Jubilee pipe patch

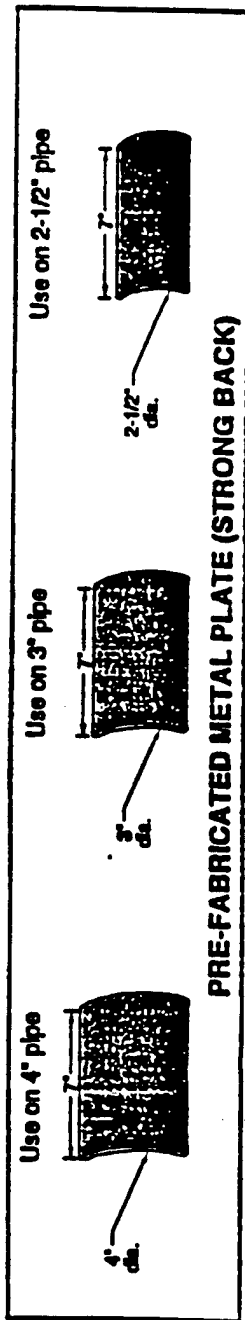

PRE-FABRICATED METAL PLATE (STRONG BACK)

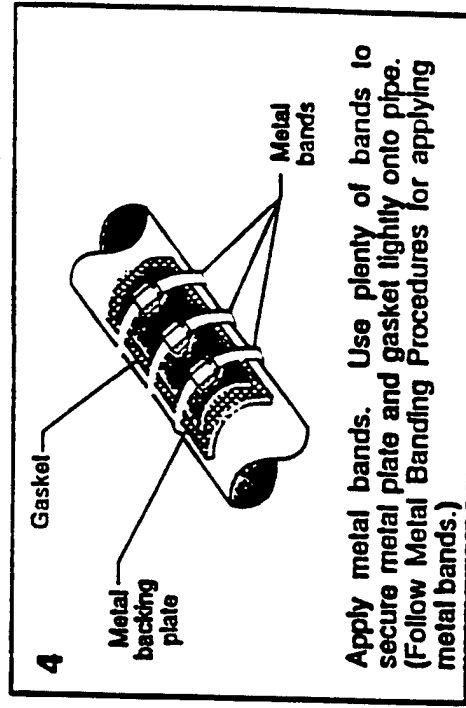
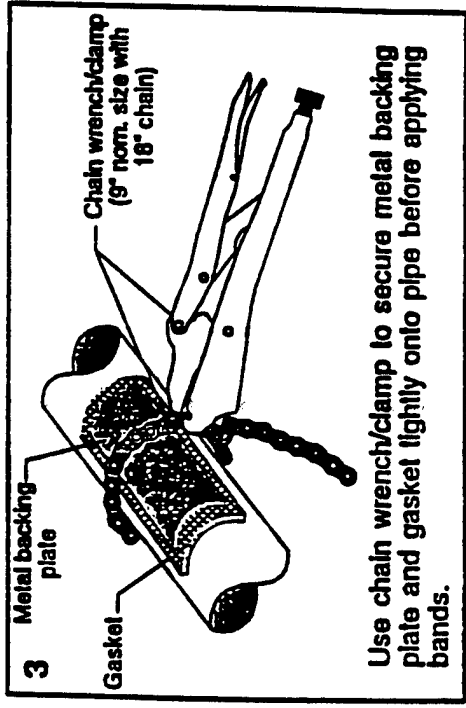
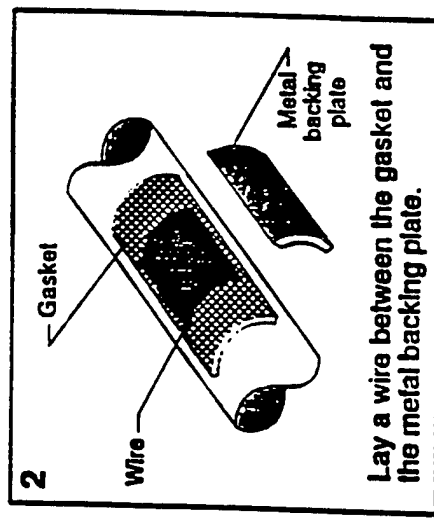
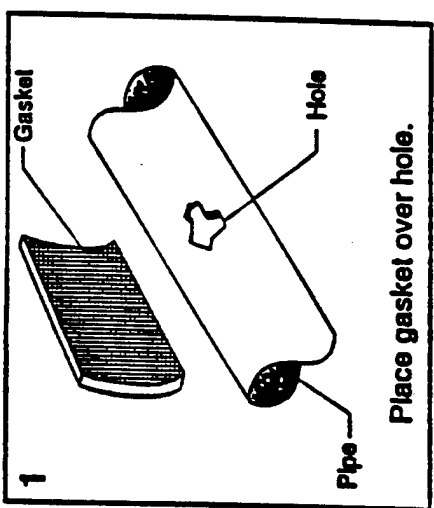

Fig. 5 -- Banding kit with chain wrench pipe patch

6.3.1 Wooden I-shore

The all wood I-shore is shown in Figure 6. A piece of wooden shoring was cut to length (hatch cover to overhead) with a dimensional allowance for placing a doubler plate against the overhead, a doubler plate covering the hatch, and two wedges inserted between the vertical shoring and the hatch doubler plate. The purpose of the doubler plates is to disperse the pressure over a greater area for additional strength. With the upright shoring and upper and lower doubler plates in place, the two wedges were driven under the shoring until the pressure exerted by the shore was deemed adequate to hold the hatch cover in place.

6.3.2 Wood/Metal Combination I-shore

The wood/metal combination I-shore, also shown in Figure 6, is similar to the wooden I-shore except that the vertical shore is replaced with a piece of telescoping steel. The steel shore is equipped with preset spring loaded stops and a screw jack for manual adjustment. This shore was constructed by first setting the upper and lower doubler plates in place. After the doubler plates were positioned, the metal shore was telescoped to the furthest spring loaded stop. The manual screw jack was then adjusted to hold the doubler plates in position, while maintaining the desired pressure on the hatch cover.

6.3.3 Wooden K-shore

The wooden K-shore, shown in Figure 7, was used to strengthen and support a weakened bulkhead. The first step in constructing this shore was to establish the upper and lower anchor points for the arms of the K-shoring. The lower anchor point for the shore foot was provided by a horizontal support (wood shoring) cut to extend to the closest intact structural member. The upper anchor point was provided by an existing transverse stiffener. The upper and lower legs were then cut to length, with allowance for the thickness of the strongback placed against the weakened bulkhead. The ends of the upper and lower legs were cut to obtuse angular points of approximately 90 degrees, such that the load bearing surfaces were parallel to the adjacent bearing surfaces of the deck, stiffeners, strongback, and shores. The entire K-shore was then tightened up using wedges as necessary between the shore legs and the strongback, the deck, and the overhead. Where required, lag bolts were used to fasten the wooden members in place.

6.3.4 Wood/Metal Combination K-shore

The wood/metal combination K-shore is shown in Figure 8. The anchor points for the upper and lower legs were established by cutting a piece of wooden shoring and then positioning it vertically with wedges. The lower horizontal support was placed on the deck between the vertical shore and the closest structural member, then tightened in place with wedges. The upper horizontal support was positioned between the vertical shore and the closest structural member, approximately 0.5 m (1.5 ft) from the overhead, then tightened in place with wedges. Two strongbacks were then positioned adjacent to each other and flush against the weakened bulkhead at the approximate midpoint between the deck and the overhead. Two telescoping metal shores were then positioned, with one between the lower end of the vertical wooden shore and the strongback and the other between the upper end of the vertical wooden shore and the strongback. After telescoping the shores, the self-aligning ends were lag bolted in place and then the shores were tightened with the adjustable screw jacks.

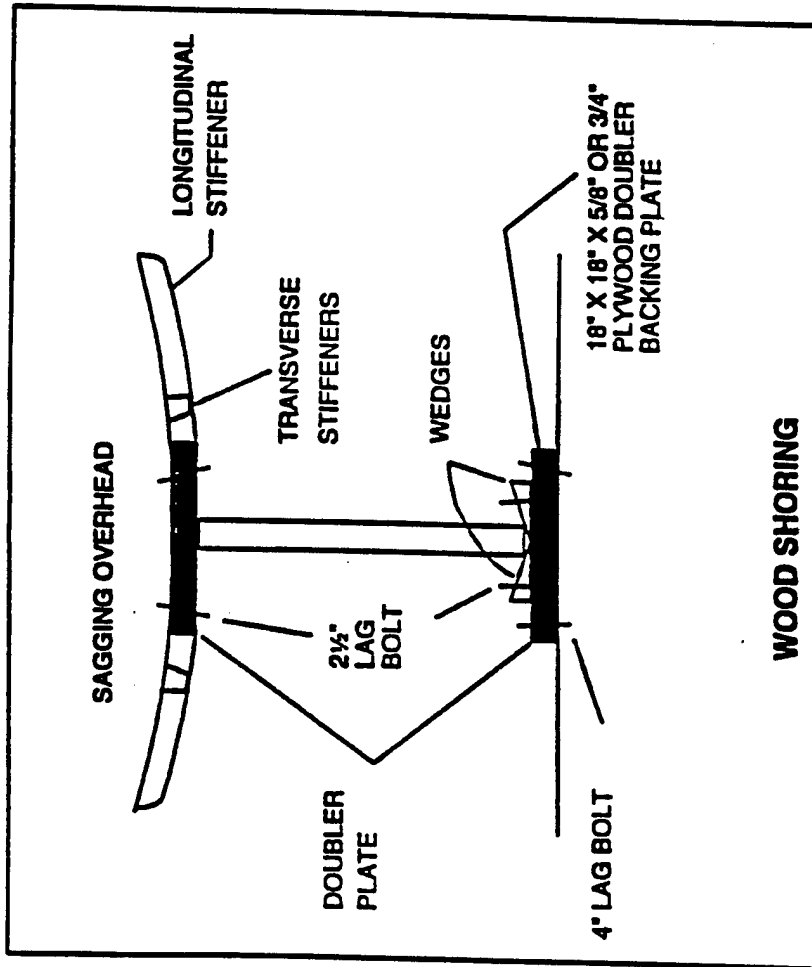
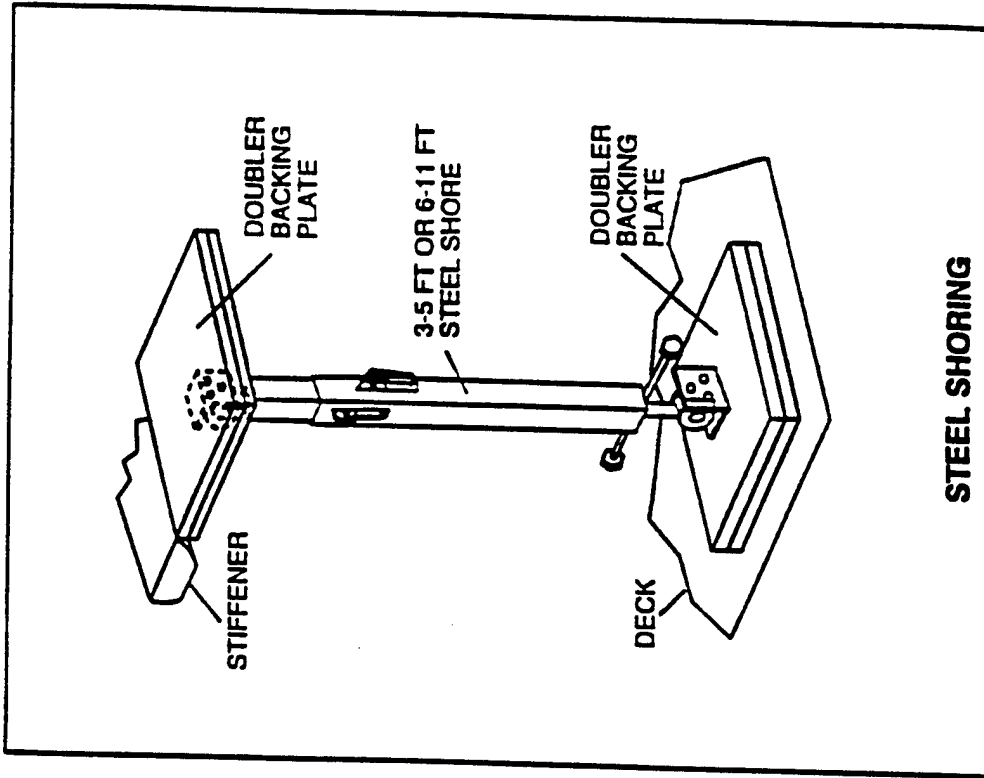

Fig. 6 - I-type shoring

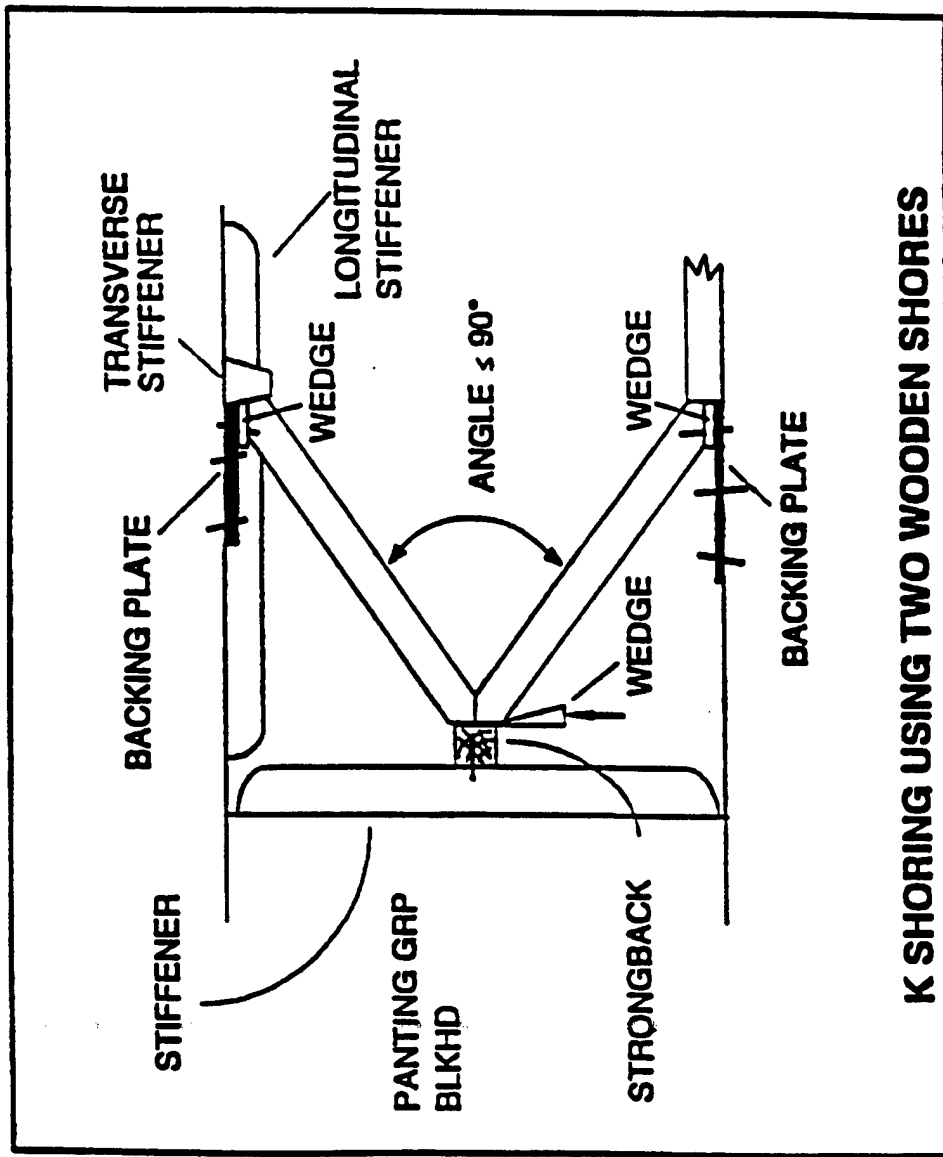

Fig. 7 – Wooden K-type shoring

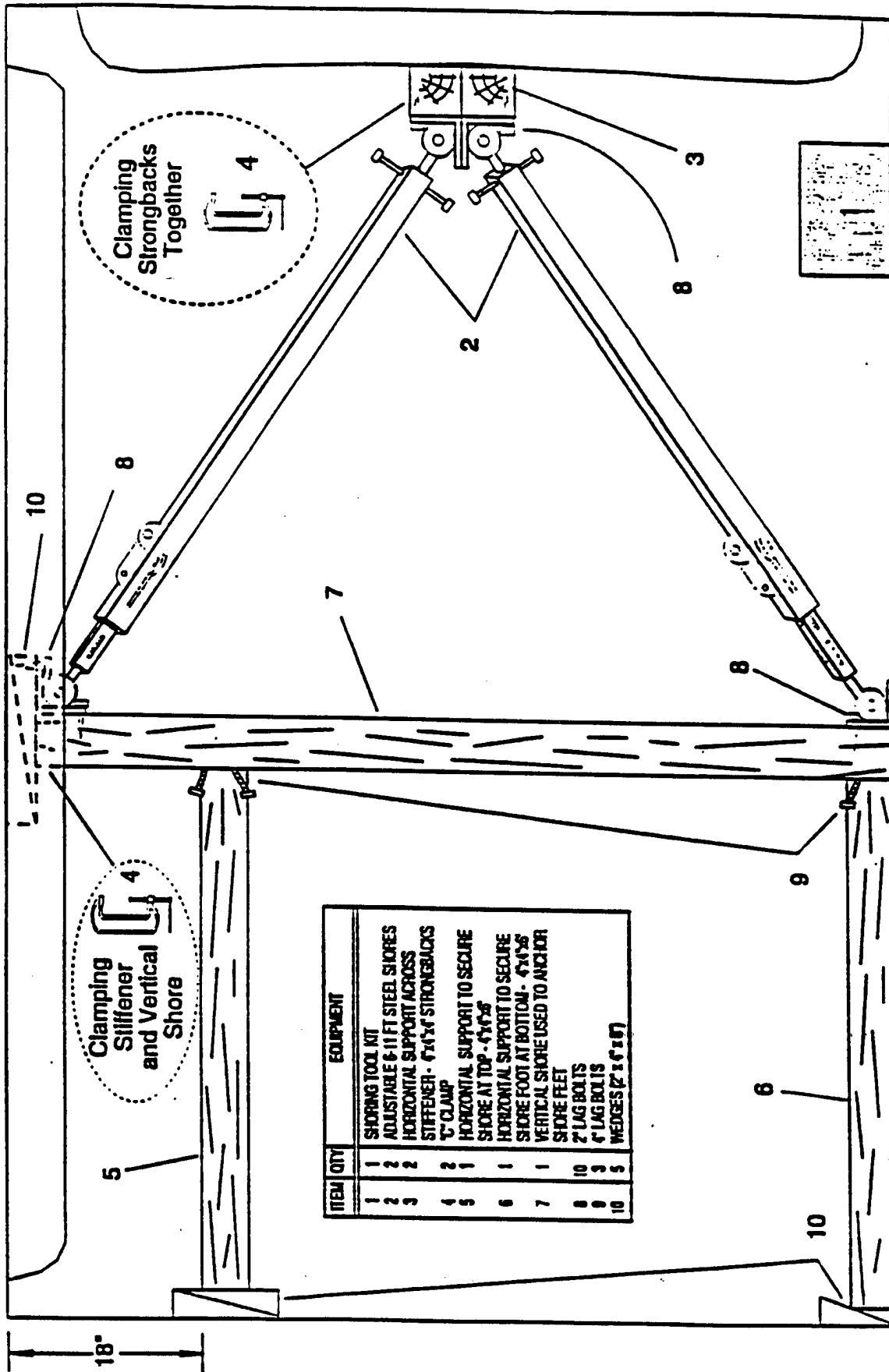

Fig. 8 - Wood/metal combination K-shore

6.4 Dewatering Procedures

The dewatering tests were performed using the P-250, the P-100, and the electrical submersible pumps. Dewatering of the Upper Wet Compartment, was performed from the port wing wall on the main deck. A scuttle (QAS 1-93-2), located inboard of the Fan Room, provided access to the Upper Wet Compartment. The respective procedures for dewatering using the foot valves and the eductors are essentially the same whether coupled to the P-250 or the P-100.

6.4.1 P-250/P-100 with Foot Valve Dewatering Procedures

When personnel dewatered with the suction hose and foot valve, the P-250/P-100 pump and hoses were positioned on the weather deck. The suction hose and foot valve were lowered through a scuttle (QAS 1-93-2) to the flooded compartment. This resulted in a lift of approximately 3.0 m (10 ft). The pump was rigged as shown in Figure 9. After the suction hose was primed on the P-250, the pump was started. To conserve water, the pumped water was discharged to designated ballast tanks instead of overboard.

6.4.2 P-250/P-100 with 38.1 mm (1.5 in.) Eductor Dewatering Procedures

When personnel dewatered with the 38.1 mm (1.5 in.) eductor, the pump was connected to the foot valve as described in section 6.4.1, however, the pump discharge was connected via a fire hose to the eductor. A discharge hose was connected to the eductor and lowered into the compartment with the foot valve. The suction hose was primed prior to starting the pump and the pumped water was discharged into a ballast tank. This configuration is shown in Figure 9.

6.4.3 Electrical Submersible Dewatering Procedures

Prior to each dewatering test involving the electrical submersible pump, the pump was checked for ground faults by an electrician. The pump was equipped with a 63.5 mm (2.5 in.) discharge hose and then lowered into the compartment through a scuttle (QAS 1-93-2). After directing the discharge hose to a designated ballast tank, the pump was connected to a 440 VAC power source and energized. The pump configuration for the electrical submersible pump is shown in Figure 10.

6.5 Hull Repair Procedures

All of the hull repair tests were performed in the Upper Wet Compartment using the double hull tank. The hull damages included holes resulting from implosions and explosions. Temporary repairs were effected with the Bucket/Box patches using J and T bolts and with a combination of wooden wedges and plugs.

6.5.1 Bucket/Box Patch Repair Procedures

The hull damages were patched using either the box or the bucket patches. The procedures for each of these repairs were similar. Both the bucket and the box had predrilled holes in them. Depending on the nature of the hull rupture, either "J" bolts or "T" bolts were inserted through the holes in bucket/box with the "J" or "T" outside of the concave side of the patch. The bolts were secured with nuts and washers on the convex side. Gasket material available from the repair locker was positioned between the bucket/box and the hull. The bolts were positioned such that the "J" or "T" was over the solid plating. The patches were then drawn tight to the hull/gasket with the nuts on the inner end until the leakage was stopped or minimized. The bucket/box patch is shown in Figure 11.

ITEM	QTY	EQUIPMENT
1	1	2-1/2" x 50' FIREHOSE
2	2	1-1/2" x 50' FIREHOSE
3	1	TRIGATE, 2-1/2" INLET x (1) 2-1/2" & (2) 1-1/2" OUTLETS
4	1	2-1/2" x 2-1/2" JUMPER DISCHARGE HOSE
5	1	P250 MOD 2 PUMP W/ JPS FUEL TANK
6	1	2-1/2" EDUCTOR, PERI-JET W/ 2" x 50' HANDLING LINE
7	1	ADAPTER- 3" FEMALE TO 4" MALE FITTING
8	Note 1	3" x 10' HARD RUBBER SUCTION HOSE

Note 1: Three or more lengths of suction hose required for lifts over 20'

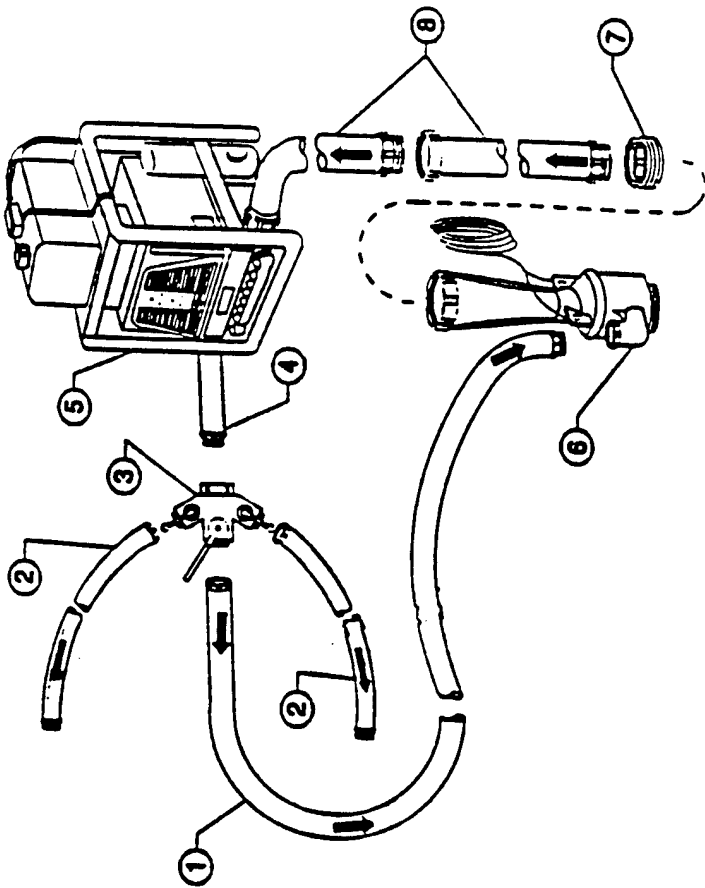

Dewatering with Combination of Eductor and P250 Pump

OR

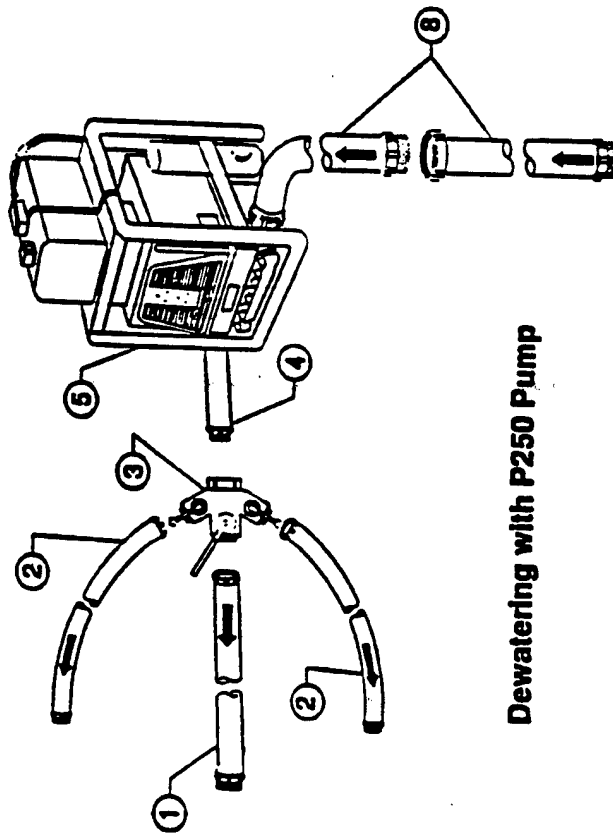

Dewatering with P250 Pump

Fig. 9 - P250/P100 pump configurations for suction lifts under 6.1 m (20 ft)

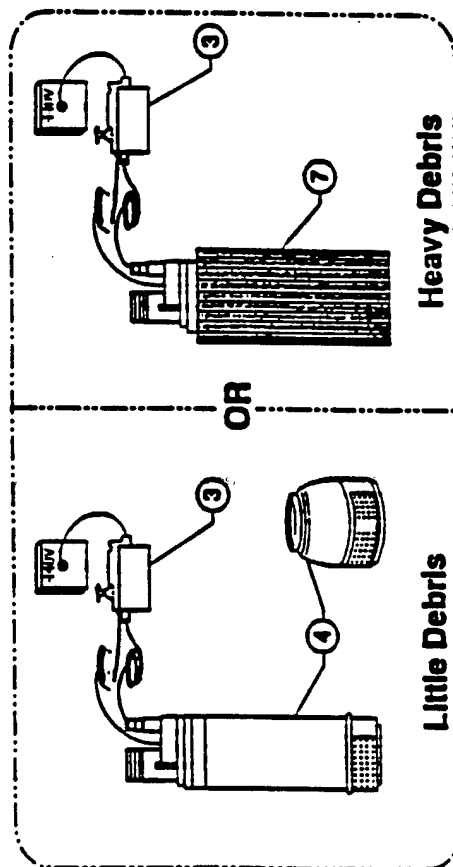
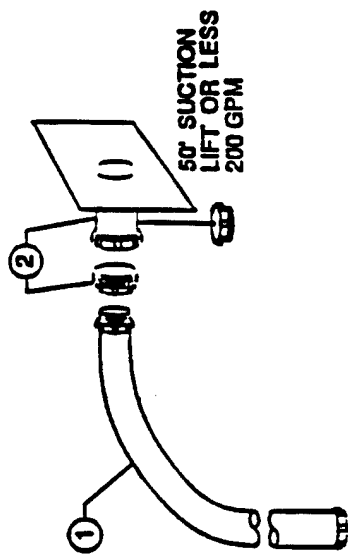
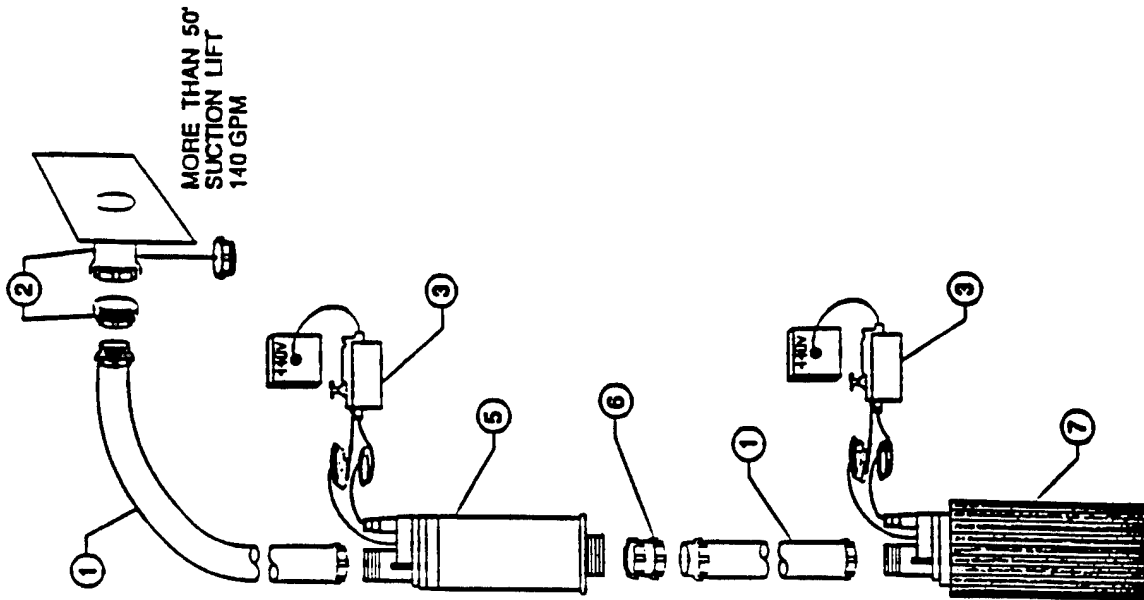

ITEM	QTY	EQUIPMENT
1	1(2)	3-1/2" FRESH
2	1	4" OVERFLOW DISCHARGE CONNECTION W/ INSTALLED ADAPTER - 4" MALE TO 2-1/2" FEMALE FITTING AND CAP (REMOVE CAP ONLY)
3	1(2)	CONTROL BOX FOR SUB PUMP PLUGGED INTO 440V OUTLET
4	1	ELECTRIC SUB PUMP W/ 2-1/2" FOOT VALVE AND STRAINER
5	1	ELECTRIC SUB PUMP
6	1	ADAPTER - 2-1/2" DOUBLE FEMALE FITTING
7	1	ELECTRIC SUB PUMP ENCASED IN STAR STRAINER

Fig. 10 - Electrical submersible pump configuration

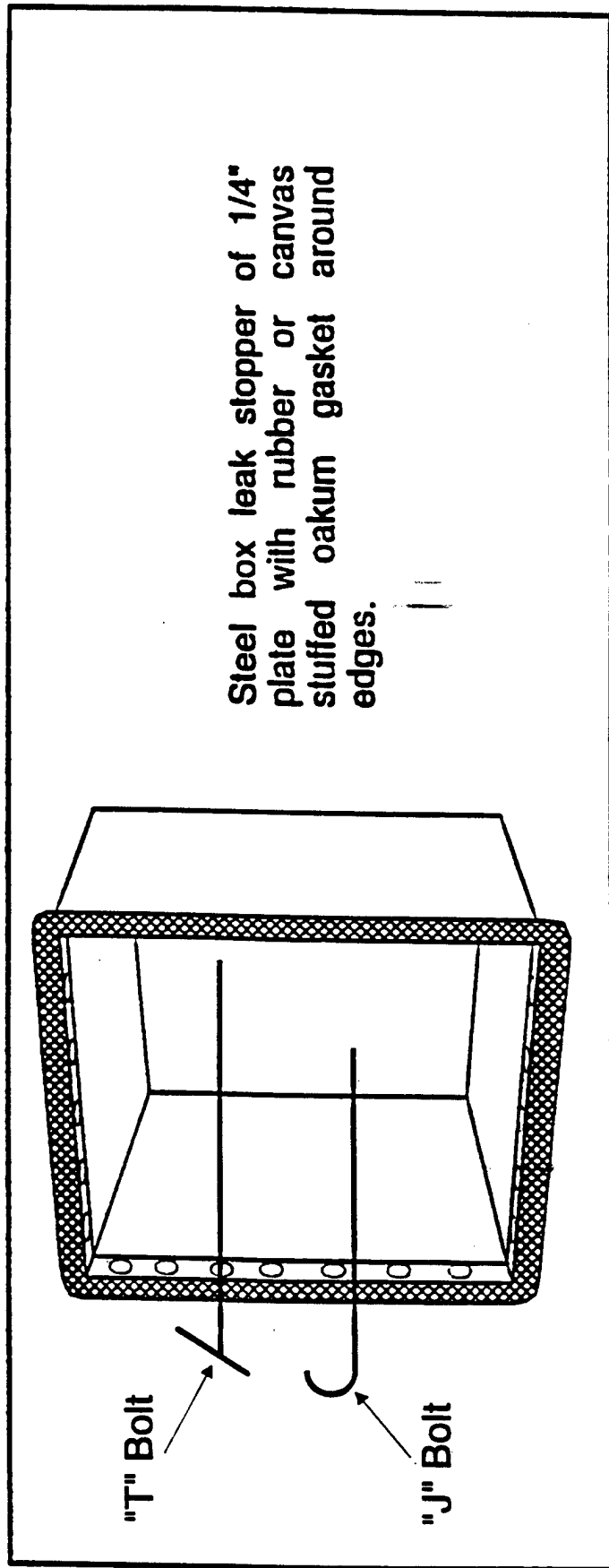

Fig. 11 -- Box patch hull repair

6.5.2 Plugs and Wedges Repair Procedures

The hull damages were repaired using plugs and wedges and a gasket material. The largest plug or wedge which could be wedged in the hole was inserted first. This was followed with progressively smaller plugs and wedges, wrapped with a sealant material such as gaskets, canvas, and oakum, being inserted into the remaining parts of the hole until the leakage was minimized or stopped. This repair is shown in Figure 12.

7.0 RESULTS AND DISCUSSION

The results of these tests focused primarily on the effectiveness of the repair activity and the time to complete the repair. The time to complete the repair was recorded by both the on-scene observers and the control room. The effectiveness of the repair was determined by the on-scene observers and analysis of the data. The on-scene observers made their judgements based on a set of effectiveness criteria. They determined if the repair was effectively completed in accordance with Naval Ship Technical Manual (NSTM) Chapter 079 Volume 2 [2]. This determination resulted in either an effective, marginal, or ineffective rating from the on-scene observers. Data analysis was required for the pipe patching tests to determine if the repair satisfied the quantitative criteria (i.e. flow reduction). The effectiveness criteria for each repair activity are shown in Table 1. The overall effectiveness is a combination of the qualitative effectiveness, determined by the on-scene observer, and the quantitative effectiveness. If either of these was marginal or ineffective then the overall effectiveness was judged to be marginal or ineffective.

Table 1. Summary of Effectiveness Criteria

Repair	Effectiveness Criteria
Pipe patch - Jubilee patch	time to complete repair < 45 minutes
	90-95% reduction in flow
Pipe patch - banding kit	time to complete repair < 45 minutes
	90-95% reduction in flow
Shoring	time to complete repair < 45 minutes
	structurally sound shore
Dewatering	time to rig dewatering equipment
	time to sustain dewatering (time of water discharge through hose minus the rig time)
	dewatering rate
Hull patch	time to complete repair < 45 minutes
	reduction in flow rate such that it is less than the assumed dewatering rate of 455 Lpm (250 gpm)

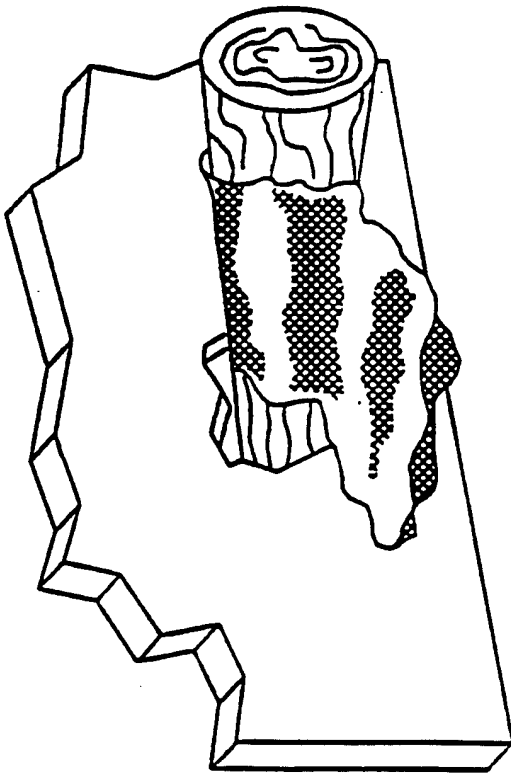

Stop jagged leaks using combinations of conical/square ended plugs and wedges.

OR

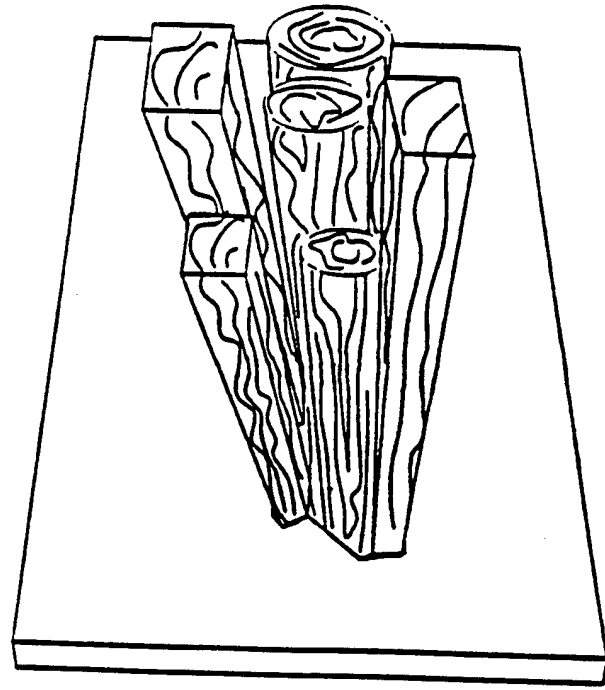

Stop jagged leaks by inserting plug wrapped with cloth.

Fig. 12 – Plugs and wedges hull repair

A statistical analysis has been performed by Desmatics, Inc. [5]. The results of that analysis will be formally presented in a separate report. However, preliminary results from that analysis have been included in this discussion.

7.1 Pipe Patching

A total of 27 pipe patching tests were conducted on a pressurized (non-isolated) line. In other words, water was continuously being supplied to the rupture during the test. Both the pipe rupture and pipe patching material were varied. There were four different pipe ruptures and two different pipe patching materials, resulting in eight different scenarios. The pipe ruptures included (1) Rupture 6, 3.5 in. firemain, (2) Rupture 3, 3.5 in. firemain, (3) Rupture 3, 2.4 in. firemain, and (4) Rupture 4, 2.4 in. chill water. The pipe patching materials included the Jubilee patch and the pipe wrench used in conjunction with the banding kit.

Each test scenario was repeated three times, resulting in 24 tests. Due to the large number of tests required and the time required to rest the repair teams, two repair teams were needed. For consistency, all of the tests for a particular scenario were performed by the same team, either B1 or B2.

Table 2 summarizes the data for each pipe patching test. Included in this Table are the following: (1) test number, (2) test scenario, (3) repair team number, (4) static pressure in the water line, (5) flow rate through the water line, (6) residual pressure in the water line when the leak was initiated (measured at 2-88-2), (7) residual water pressure at the completion of the test, (8) flow rate at the completion of the test; (9) overall effectiveness as determined by the team observer, and (10) the time to complete the repair activity. The on-scene observers determined the ability of the team to properly effect the repair. An analysis of the flow rate data was conducted to determine if the flow reduction criteria contained in Table 1 were satisfied.

The Jubilee patch was significantly more effective than the banding kit in each of the scenarios tested with the exception of Rupture 4, 2 in. Chill Water. In each of the firemain scenarios the Jubilee patch was effectively installed in less than nine minutes, reducing the flow rate to zero in all but one test (5-06). The pipe wrench with banding kit took more than 25 minutes to install and was ineffective each time. For the Chill Water scenario, the pipe wrench with banding kit was more effective than the Jubilee patch, but required greater than 25 minutes to install and in one case almost 44 minutes. In each of the Chill Water tests the Jubilee patch was ineffective. The cause of the reduction in the performance of the Jubilee patch is not obvious, but it is believed that the length of the rupture (152 mm (6.0 in)) and the resulting difficulty in centering the patch exactly across the hole may have been the cause. More tests, using a smaller rupture, will need to be performed to determine if this was the case.

Although they are not shown in all of the scenarios, learning effects may be evident in some cases. In tests involving Jubilee patches evidence of learning effects can be seen. For example, the repair times for the Rupture 6, 3.5 in. firemain scenario decreased from 6:24 to 5:48 between the first (Test 3-03) and second (Test 5-06) tests for that scenario and from 5:48 to 3:29 between the second (test 5-06) and third (Test 2-02-2) tests. Learning effects can also be seen in the Rupture 3, 2 in. firemain scenario. For this scenario, the repair times were 2:21, 2:00, and 1:49 for the first (Test 3-06), second (Test 1-06-2), and third (Test 5-03) tests, respectively.

Table 2. Summary of Pipe Patching Tests

Test	Damage/Repair Equipment	Team	Static Pressure (bar (psii))	Flow (Lpm (gpm))	Residual Pressure (bar (psii))	Residual Pressure at Test Completion (bar (psii))	Flow at Test Completion (Lpm (gpm))	Total Flow (L (gal))	Overall Effectiveness of Repair	Repair Time (min:sec)
1-08	Rupture 6, 3-in. firemain / pipe wrench with banding kit	B2	7.5 (109)	644 (170)	1.4 (20)	3.6 (53)	458 (121)	15051 (3976)	ineffective	30:00
4-04			7.5 (109)	644 (170)	1.5 (22)	4.1 (60)	386 (102)	16005 (4228)	ineffective	30:16
6-04			7.4 (108)	636 (168)	1.4 (20)	5.5 (80)	288 (76)	12795 (3380)	ineffective	30:25
3-03	Rupture 6, 3-in. firemain / Jubilee patch	B1	7.6 (111)	606 (160)	1.4 (20)	7.6 (111)	0 (0)	3036 (802)	effective	6:24
5-06			7.6 (111)	662 (175)	1.4 (20)	7.6 (111)	38 (10)	2165 (572)	effective	5:48
2-02-2	Rupture 3, 3.5 in. firemain / pipe wrench with banding kit	B1	7.6 (110)	587 (155)	1.7 (25)	7.4 (108)	0 (0)	7711 (448)	effective	3:29
1-01			7.6 (110)	598 (158)	1.4 (20)	4.5 (66)	348 (92)	13972 (3691)	ineffective	26:00
3-08			7.7 (112)	590 (156)	1.6 (23)	6.8 (98)	163 (43)	13150 (3474)	ineffective	30:39
6-02			7.7 (112)	587 (155)	1.6 (24)	6.6 (96)	163 (43)	9286 (2453)	ineffective	31:07
3-01	Rupture 3, 3.5 in. firemain / Jubilee patch	B2	7.7 (112)	598 (158)	1.0 (15)	7.6 (110)	0 (0)	3089 (816)	effective	6:48
2-04-2			7.7 (112)	583 (154)	1.7 (25)	7.0 (102)	0 (0)	3229 (853)	effective	7:28
6-07			7.7 (112)	590 (156)	1.6 (24)	7.6 (111)	0 (0)	3047 (805)	effective	8:23
2-07-2	Rupture 4, 2-in. chill water / pipe wrench with banding kit	B2	3.8 (55)	49 (13)	0 (0)	1.8 (26)	38 (10)	1109 (293)	ineffective	27:50
4-02			3.8 (55)	49 (13)	0 (0)	3.6 (52)	0 (0)	1030 (272)	effective	43:39
5-08			3.8 (55)	38 (10)	0 (0)	3.5 (51)	0 (0)	450 (119)	effective	25:31
4-09	Rupture 4, 2-in. chill water / Jubilee patch	B1	3.8 (55)	49 (13)	0 (0)	3.2 (46)	15 (4)	466 (123)	ineffective	12:44
5-01			3.4 (50)	38 (10)	0 (0)	3.4 (50)	8 (2)	223 (59)	ineffective	7:09
2-09			3.8 (55)	49 (13)	0 (0)	3.4 (50)	26 (7)	1064 (281)	ineffective	22:57
1-03	Rupture 3, 2.4 in. firemain / pipe wrench with banding kit	B1	7.5 (109)	587 (155)	1.0 (15)	7.3 (106)	98 (26)	7166 (1893)	ineffective	29:00
4-07			7.9 (115)	568 (150)	1.4 (20)	4.1 (59)	348 (92)	12473 (3295)	ineffective	31:00
6-09			7.9 (115)	473 (125)	1.0 (15)	6.5 (94)	110 (29)	7650 (2021)	ineffective	26:35
3-06	Rupture 3, 2.4 in. firemain / Jubilee patch	B2	7.8 (113)	568 (150)	1.7 (25)	5.0 (72)	0 (0)	738 (195)	effective	2:21
1-06-2			7.6 (111)	590 (156)	1.7 (25)	4.1 (59)	0 (0)	568 (150)	effective	2:00
5-03			7.8 (113)	594 (157)	2.1 (30)	5.3 (77)	0 (0)	416 (110)	effective	1:49

Based on the results of these tests, it is obvious that the banding kit is not effective on pressurized systems. However, the effectiveness of the banding kit may be increased with the use of banding clips which permit double raps of banding material. The flexible sheet metal strongbacks were preferred over the carbon steel and PVC strongbacks.

The preliminary results of the statistical analysis conducted by Desmatics, Inc. indicate that the following have statistically significant differences: 1) Firemain pipes require less time to repair than the Chill Water pipes; 2) The use of Jubilee patches results in shorter repair times than the banding kits; and 3) For the Firemain ruptures, use of the Jubilee patch results in greater flow rate reductions than the banding kits. The analysis also indicates that there are no significant differences in the flow rate reductions between the two repair methods for the Chill Water ruptures.

The on-scene observers made several observations during the course of these tests. First, with respect to manning, a two person pipe patching team appears to be adequate for each of these scenarios. Second, the gloves with adhesive were determined to be a good addition to the pipe patching kit, especially when handling the banding equipment and materials. Third, due to the ineffectiveness of the banding kit on pressurized systems, dividing the pipe patching kit into two separate kits, Jubilee and banding kits, may be beneficial. Separating the two kits would allow the initial repair team to respond much quicker with the Jubilee kit for incidents involving pressurized systems which cannot be isolated. Fourth, the addition of a deep socket ratchet would decrease the amount of time required to install the Jubilee patch.

7.2 Shoring

A total of 12 shoring tests were conducted during this test series. These tests involved two different types of shores (I and K) constructed with two types of materials (wood only and metal and wood), resulting in four different scenarios. Each scenario was repeated three times. All 12 of the shoring tests were performed by the same team (Team C).

A summary of the results of the shoring tests is contained in Table 3. This table contains the test number, the test scenario (type of shore and repair equipment), the overall effectiveness, and the repair time. For the shoring tests the overall effectiveness was a qualitative assessment made by the on-scene observer, based on the time to complete the repair and the structural integrity of the shore.

In each of the shoring scenarios, the first test for that scenario took considerably longer than the other two tests. For example, for an all wood I-shore, the repair team completed the shore in 12:55 in the first test (Test 2-08) and 3:11 in the second test (Test 1-02). The wood/metal combination K-shore had the smallest time reduction between the first and second tests. The first test (Test 2-03) required 17:00 and the second test (Test 1-09) required 12:28. The reduction in repair time is most likely the result of the experience gained from the first test of each scenario. This was confirmed in the statistical analysis.

There was a negligible time difference in the times to construct the two types of I-shores. This is due to the simplicity of the shore and the fact that the metal replaces a piece of wood which is easily measured. There was a significant time difference in the times to construct the two types of K-shores. The wood K-shore took more than twice as long to construct than the metal and wood shore. This is due to the fact that the piece of wood replaced by the metal shore is difficult to measure. The measurement difficulties are a result of the slope in the bulkhead, which made measuring the run difficult. These findings are supported by the preliminary results of the statistical analysis.

Table 3. Summary of Shoring Tests

Test	Scenario/Equipment	Team	Overall Effectiveness	Repair Time (min:sec)
2-08	I shore on WTH 3-94-2 / wood only	C	effective	12:55
1-02			marginal	3:11
3-04			effective	4:10
2-10	I shore on WTH 3-94-2 / metal and wood	C	effective	10:26
1-04			effective	2:48
3-02			effective	4:12
2-05	K shore outboard bulkhead at FR 92 / wood only	C	effective	42:32
1-07			marginal	33:31
3-09			effective	27:37
2-03	K shore outboard bulkhead at FR 92 / metal and wood	C	effective	17:00
1-09			effective	12:28
3-07			effective	12:23

The observer made two notable observations. First, a three person shoring team appears to be adequate. Additional team members would be required if a second shore were required to be installed in another location, due to the fact that one team member must maintain a watch on the shore. Second, the addition of a 25-ft retractable tape measure could make measuring a one person operation, as opposed to the two people required to use the 100-ft tape currently used.

7.3 Dewatering

A total of 16 dewatering tests were performed. All of these tests were performed by the same repair team (Team A). Five different pump configurations were used during these tests, including (1) P-100 with an 3.8 cm (1.5 in.) eductor with strainer, (2) P-100 with a foot valve and strainer, (3) P-250 with a 6.4 cm (2.5 in.) eductor, (4) P-250 with a foot valve and strainer, and (5) electrical submersible pump.

Three tests were conducted for each scenario, with two exceptions. Four tests were performed for the P-100 with the 3.8 cm (1.5 in.) eductor with strainer and two tests were performed for the P-100 with the foot valve and strainer.

A summary of the dewatering test results is included in Table 4. This table includes (1) the test number, (2) the dewatering equipment used, (3) the repair team identification, (4) the initial water depth in the upper wet compartment, (5) the calculated dewatering rate, (6) the overall effectiveness, as determined by the on-scene observer, (7) the time required to rig pump, and (8) the time to sustain dewatering. The time to sustain dewatering is the time required to get the pump running and actively dewatering. The dewatering rate was calculated using the change in the water level with respect to time and the net floor area of the compartment. Included in Table 4 are tests 3-10 and 3-10-2. The use of an improperly sized gasket in the hard rubber suction hose produced an air leak which prevented the repair team from sustaining dewatering. Due to the type of malfunction, this test was repeated (Test 3-10-2). Test 3-10 is included in the Table to call attention to the equipment failure.

The rig times for each of the dewatering equipment configurations were approximately the same, however there are significant differences in the total time to sustain dewatering. The statistical analysis showed that the electrical submersible pump requires the least amount of time and the two P-250 configurations requires the most time. The P-100 configurations fall between the electrical submersible and the P-250. The dewatering rates follow the same trend as the dewatering times with the electrical submersible having the lowest dewatering rate, the P-250 having the highest, and the P-100 in between.

Although there are no significant differences in the rig times for any of the pump configurations, there were learning effects. For each scenario tested the rig time of the second test for a given scenario was significantly lower than the rig time for the first test. For example, for the P-250 with a 64 mm (2.5 in.) eductor the rig time was reduced from 2:00 to 1:33 between the first (Test 2-01) and second (Test 3-10-2) tests. In two cases the rig times were also decreased from the second to the third tests. For the P-250 with a foot valve and strainer the rig times were 2:30, 1:19, and 1:00 for the first (Test 1-10), second (Test 4-06), and third (Test 5-10) tests, respectively. For this scenario there was also a significant reduction in the amount of time to sustain dewatering. The additional time required to sustain dewatering decreased from the 4:00 required in the first test (Test 1-10) to 3:41 in the second test (Test 4-06) and 2:46 in the third test (Test 5-10). For the electrical submersible pump the rig times were 1:30, 1:09, and 0:46 for the first (Test 2-06), second (Test 3-05), and third (Test 6-01) tests, respectively. According to the on-scene observer, a four person dewatering team provides adequate manning.

Table 4. Summary of Dewatering Tests

Test	Dewatering Equipment	Team	Initial Water Depth (mm (in.))	Dewatering Rate (Lpm (gpm))	Overall Effectiveness	Rig Time (min:sec)	Time to Sustain Dewatering (min:sec) ¹
2-11	P-100 w/ 3.8 cm (1.5 in.) eductor w/ strainer	A	760 (30)	682 (150)	effective	2:00	1:00
4-01			610 (24)	796 (175)	effective	1:02	1:06
4-11			760 (30)	796 (175)	effective	2:00	0:42
5-05			640 (25)	796 (175)	effective	1:20	0:41
1-05	P-100 w/ foot valve and strainer	A	660 (26)	1023 (225)	effective	1:30	0:30
6-06			560 (22)	1023 (225)	effective	1:03	0:34
2-01	P-250 w/ 6.4 cm (2.5-in.) eductor	A	not available	not available	effective	2:00	1:00
3-10			560 (22)	see note 2	ineffective ²	1:50	see note 2
3-10-2			560 (22)	1591 (350)	effective	1:33	1:12
6-11			660 (26)	1955 (430)	effective	1:36	2:13
1-10	P-250 w/ foot valve and strainer	A	560 (22)	1591 (350)	effective	2:30	4:00
4-06			580 (23)	1591 (350)	effective	1:19	3:41
5-10			740 (29)	1591 (350)	effective	1:00	2:46
2-06	Electrical submersible pump	A	790 (31)	568 (125)	effective	1:30	0:00
3-05			580 (23)	568 (125)	effective	1:09	0:00
6-01			610 (24)	455 (100)	effective	0:46	0:00

Note: ¹ The time to sustain dewatering is in addition to the time to rig dewatering equipment.

² Due to an improperly sized gasket in the suction hose effective dewatering was not possible.

7.4 Hull Repair

A total of 12 hull repair tests were performed, involving two different hull ruptures and two hull patches. Both an explosion rupture and an implosion rupture were evaluated with the bucket patch and plugs and wedges repair. The resulting four scenarios were each tested three times. All of the hull repairs were performed by the same repair team (Team C).

Table 5 contains a summary of the hull repair tests. This Table includes the general test information as well as the water level in the double hull tank at the initiation of the repair and at the end of the test, the overall effectiveness, and the repair time. The water level at repair initiation is the water level in the double hull tank at the time when either the first plug was successfully installed or the bolt was successfully placed in the hole. This is intended to provide an indication of the maximum allowable head pressure to initiate hull repair activities. It is important to note that the double hull tank supplying the simulated hull ruptures was not being continuously supplied, and, as a result, the head pressure decreased with time. In three tests (4-03, 4-05, and 4-10) the water level at repair initiation was less than the water level at test completion. This was a result of the water from the Pilot House tank being dumped into the double hull tank.

The bucket patch was installed more effectively and quickly than the plugs and wedges. The bucket patch required approximately 5 minutes to install compared to approximately 10:00 for the plugs and wedges repair. This is supported by the results of the statistical analysis. It is not possible to determine a maximum depth at which repairs can successfully begin based on the data collected during these tests. Further testing, specifically designed to analyze the maximum water depth, needs to be conducted to determine this height. The on-scene observer recommended that the handle for the bucket patch be perpendicular to the rod as opposed to being at some other angle. Having the handle perpendicular to the rod should provide the best results. The statistical analysis found that there were no learning effects evident in the hull repair tests.

7.5 Analysis

A statistical analysis of the data collected during this test series is being conducted separately. The preliminary results of that analysis generally support the findings discussed in this report. The second test series completed in July 1995 provided additional flooding control data for analysis. The data collected in the July test series will be discussed in a separate report. Preliminary analysis of the data collected during the May 1995 test series has been completed and the following observations can be made.

8.0 CONCLUSIONS

With respect to pipe patching, the Jubilee patch was effective on pressurized systems whereas the banding kit proved to be ineffective on all of the pressurized systems.

There appears to be little difference in the time to construct an I-shore, whether it is made of wood only or a combination of metal and wood. However, there is a substantial difference, nearly two times, in the amount of time required to construct an all wood K-shore compared to the time to construct a wood and metal K-shore. This is believed to be the result of the piece of wood that is being replaced by the metal shore. That particular piece of wood was difficult to measure due to the sloped portion of the bulkhead.

Table 5. Summary of Hull Repair Tests

Test	Scenario/Equipment	Team	Water Level in double hull tank at repair initiation (m(ft)) ¹	Water Level in double hull tank at test completion (m(ft)) ²	Overall Effectiveness	Repair Time (min:sec)
4-03	Explosion rupture / bucket patch	C	1.1 (3.7)	1.4 (4.7) ²	effective	5:20
5-04			1.4 (4.7)	1.0 (3.2)	effective	5:20
6-10			2.5 (8.3)	0.7 (2.4)	ineffective	6:55
4-05	Explosion rupture / plugs and wedges	C	1.7 (5.5)	2.0 (6.7) ²	marginal	10:40
5-09			2.3 (7.5)	1.9 (6.3)	marginal	10:44
6-03			1.7 (5.7)	0.8 (2.6)	effective	6:55
4-10	Implosion rupture / bucket patch	C	1.9 (6.1)	2.0 (6.8) ²	effective	5:17
5-02			1.7 (5.7)	1.5 (5.1)	effective	5:31
6-08			2.5 (8.3)	1.5 (4.9)	effective	4:46
4-08	Implosion rupture / plugs and wedges	C	2.5 (8.2)	1.3 (4.2)	marginal	9:20
5-07			2.5 (8.2)	1.6 (5.4)	marginal	13:27
6-05			2.5 (8.3)	1.6 (5.3)	effective	6:56

Note: ¹

² This is the water level in the double hull tank at the time either the first plug or the bolt is successfully put in place.

The higher water level at test completion is a result of additional water from the pilot house tank being dumped into the double hull tank.

Although the rigging time for the various pieces of dewatering equipment are similar, there are substantial differences in the total time required to begin dewatering and the dewatering rate. As a result, the more effective dewatering configuration may be one with a longer rigging time, depending on the flooding rate of the compartment.

With respect to hull repair, the bucket patch was substantially easier and quicker to install than the plugs and wedges. The bucket patch was much more effective. These scenarios should be investigated more thoroughly using constant head pressures, instead of a steadily decreasing head pressure.

Other conclusions relative to manning and training issues can also be made based on the data collected during this test series. Based on the observations of the on-scene observers, the current manning requirements appear to be adequate. However, a problem may exist if the shoring team is required to install a second shore in another location because one team member must maintain a watch on the first shore and will be unable to assist the repair team. Learning effects were present in the shoring and dewatering tests. This indicates that training emphasizing shoring and dewatering would be more effective than training emphasizing hull repair and pipe patching. This does not mean that pipe patching and hull repair training should be ignored, rather that training in these areas does not necessarily result in reduced repair times.

9.0 RECOMMENDATIONS

Based on the results and conclusions of this test series, the following recommendations are made: 1) A more thorough evaluation of hull repairs needs to be conducted. During the May 1995 test series, the water level was not maintained in the double hull tank which supplied the hull ruptures. Any further hull repair evaluations should emphasize maintaining constant and/or increasing head pressures to evaluate more realistic scenarios. 2) Training should emphasize areas where learning effects are determined to exist (i.e. shoring and dewatering). 3) A 25 ft retractable tape should be included in the shoring kit, along with the 100 ft steel tape. 4) The use of metal shoring materials should be recommended for K-shores involving odd compartment configurations. 5) Differences in the rig and dewatering times and dewatering rates of the available dewatering equipment should be emphasized to aid in equipment selection.

The repair of isolated (non-pressurized) pipe systems and the use of shoring in conjunction with hull repairs will be presented in the report for the July 1995 test series.

10.0 ACKNOWLEDGMENT

NRL is especially grateful to crew members of the USS ENTERPRISE (CVN65) for their enthusiastic participation. The individuals who participated were LCDR David J. Zilber, LT Charles G. Simpson, CW02 Harold H. Harrell, HTC Brian K. Fry, DC2 Sherwood Massenburg, DC2 Calvin Nance, DC3 John T. Bryant, DC3 Joshua S. Briseno, DC3 John D. Yates, II, HT3 Robert J. Kennedy and HTFN Earl R. Frantz.

11.0 REFERENCES

1. "Surface Ship Survivability", NWP 62-1 (Rev. D), Department of the Navy, Washington, D.C., January 1993.
2. "Practical Damage Control," Naval Ships' Technical Manual, Chapter 079, Volume 2, Naval Sea Systems Command, December 15, 1979.
3. Carhart, H.W., Toomey, T.A., and Williams, F.W., "The Ex-SHADWELL Full Scale Fire Research and Test Ship," NRL Memorandum Report 6074, Naval Research Laboratory, Washington, D.C., October 6, 1987, re-issued September 1992.
4. Naval Sea Systems Command, "Full Scale Damage Control Engineering Evaluations FY 95 Test Plan," NAVSEA 9555 03G1/76, April 28, 1995.
5. Smith, D. E., "Statistical Analysis of the Results of the Initial Damage Control Experiments on the ex-USS SHADWELL," Desmatics Technical Report No. 159-1, July, 1995.

Appendix A
Instrumentation Drawings

INSTRUMENT KEY

(A)	AUDIO
(P)	PRESSURE
(V)	VIDEO CAMERA
(S)	DOOR MICROSWITCH
(T)	THERMOCOUPLE TREE
(U)	ULTRASONIC FLOW METER
(F)	TURBINE FLOW METER

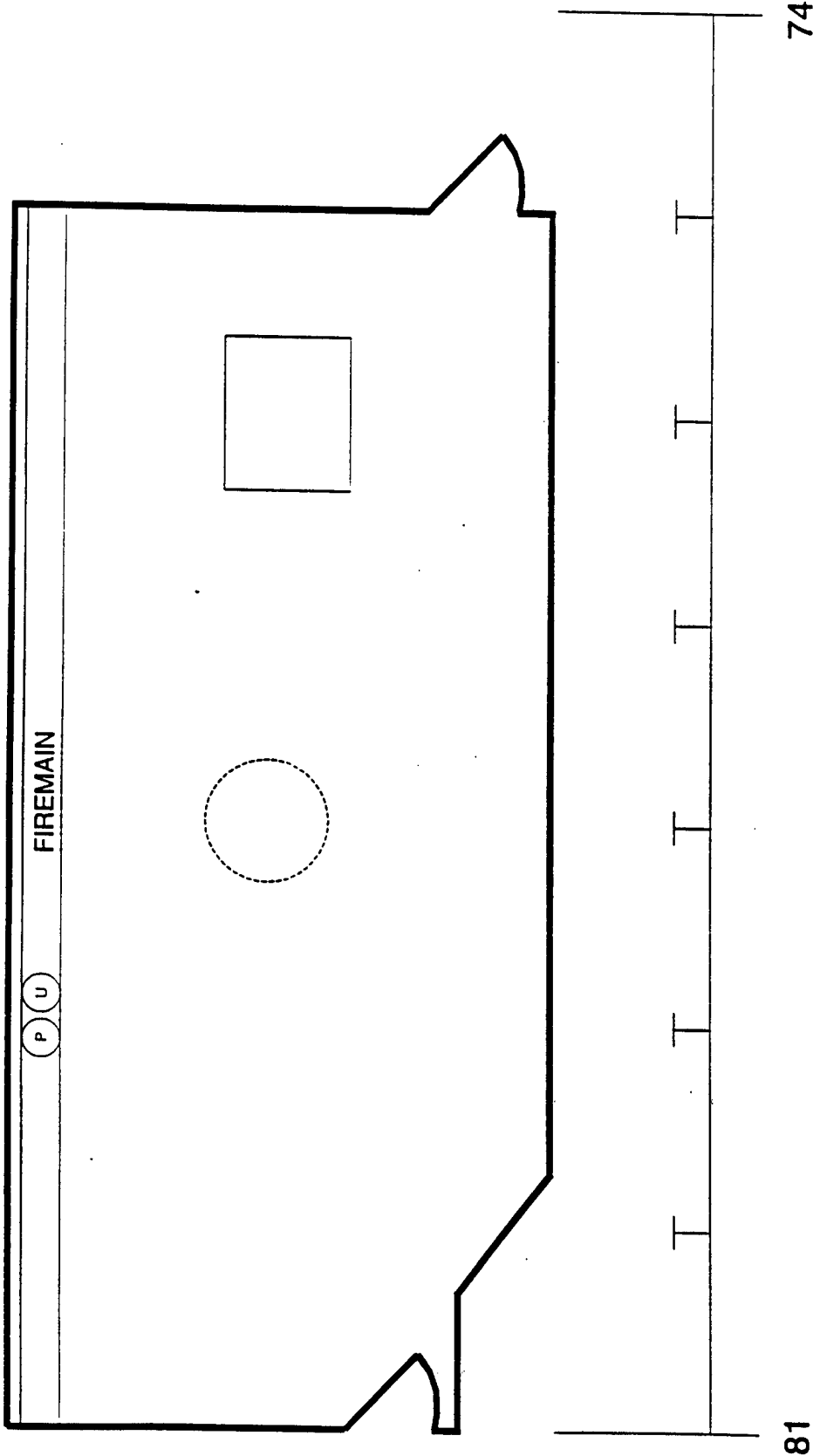

1ST PLATFORM	REV: 7/5/95
FILE: SUB1-81N	DATE: 4/19/94

Fig. A1 – Combat systems instrumentation layout

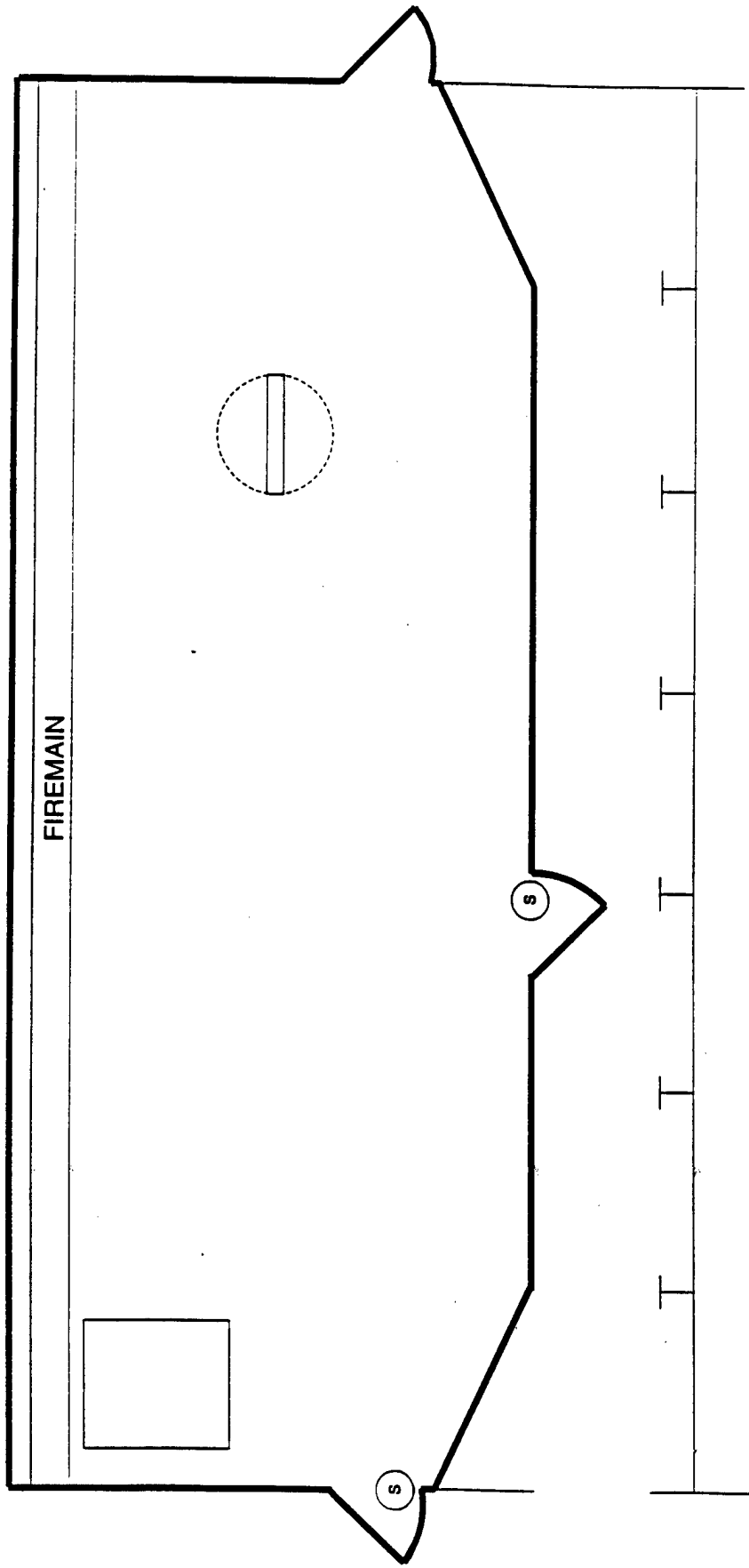

81

1ST PLATFORM	REV: 7/5/95
FILE: SUB1-88N	DATE: 11/29/94

88

Fig. A2 – Control room instrumentation layout

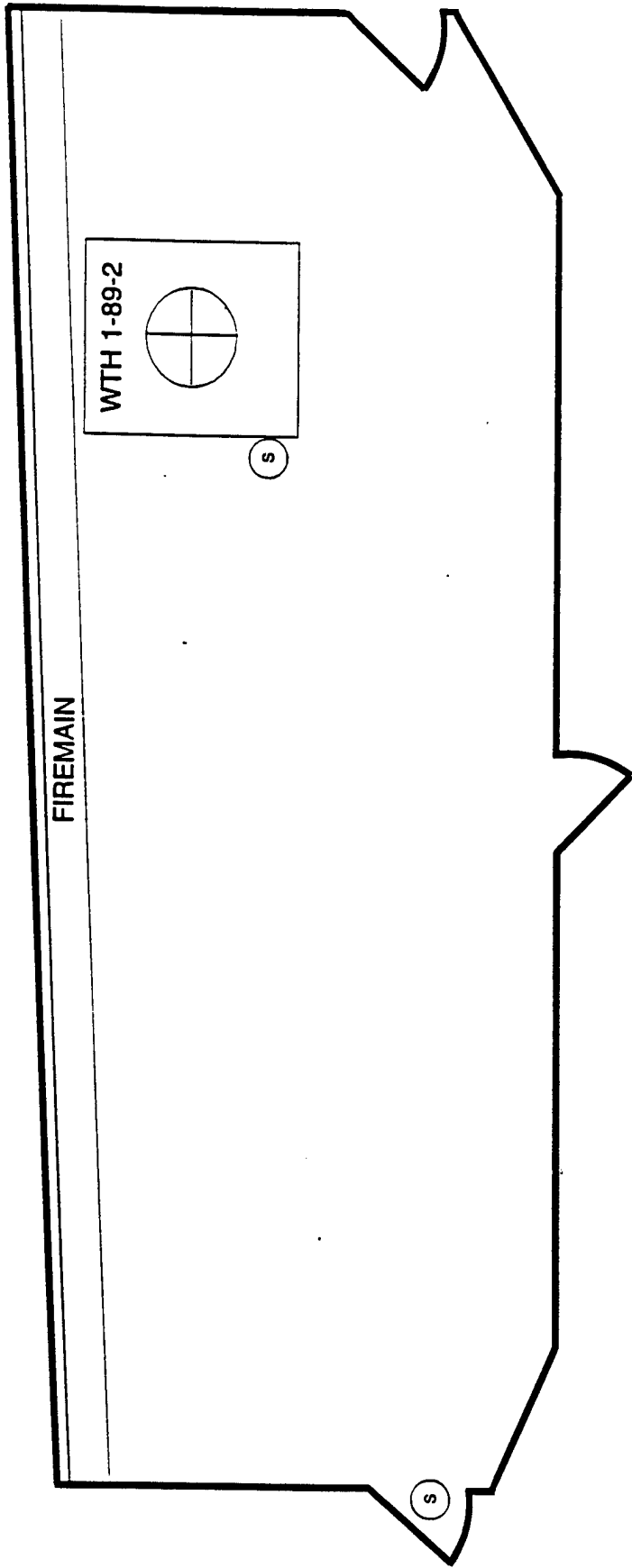

88

1ST PLATFORM	REV: 7/5/95
FILE: SUB1-95	DATE: 4/19/94

95

Fig. A3 – Fan room instrumentation layout

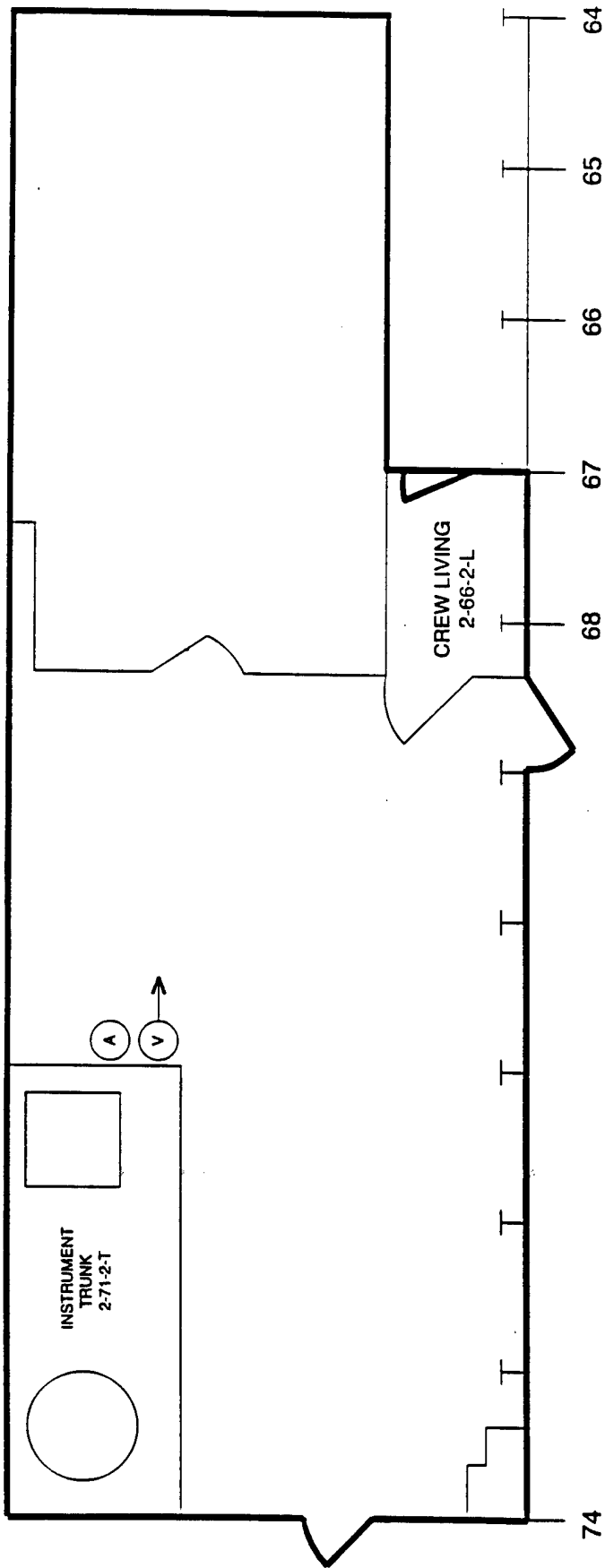

2ND PLATFORM	REV: 7/5/95
FILE: SUB2-74	DATE: 4/19/94

Fig. A4 – CPO living quarters instrumentation layout

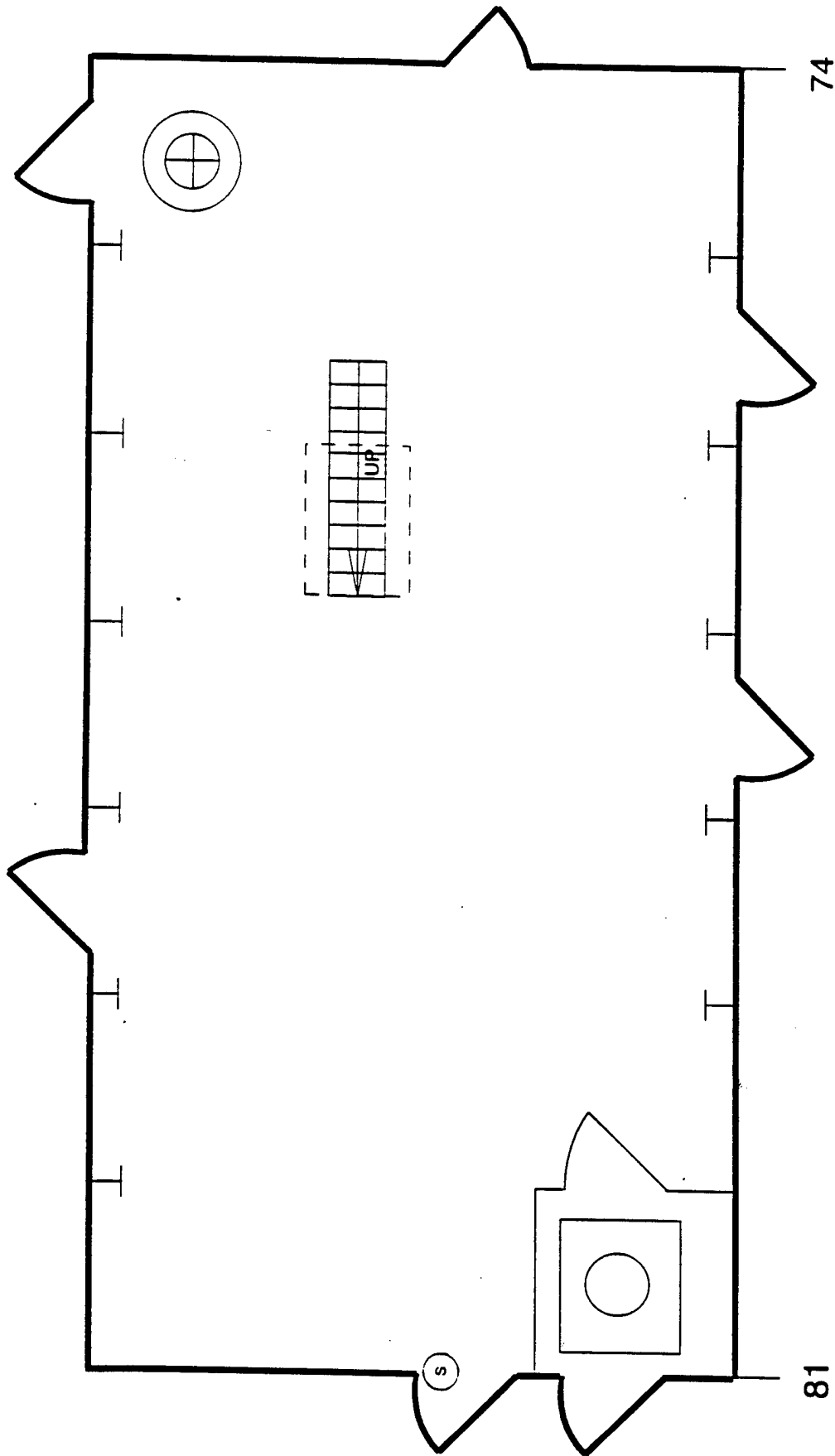

2ND PLATFORM	REV: 7/5/95
FILE: SUB2-81	DATE: 4/19/94

Fig. A5 – Crew living instrumentation layout

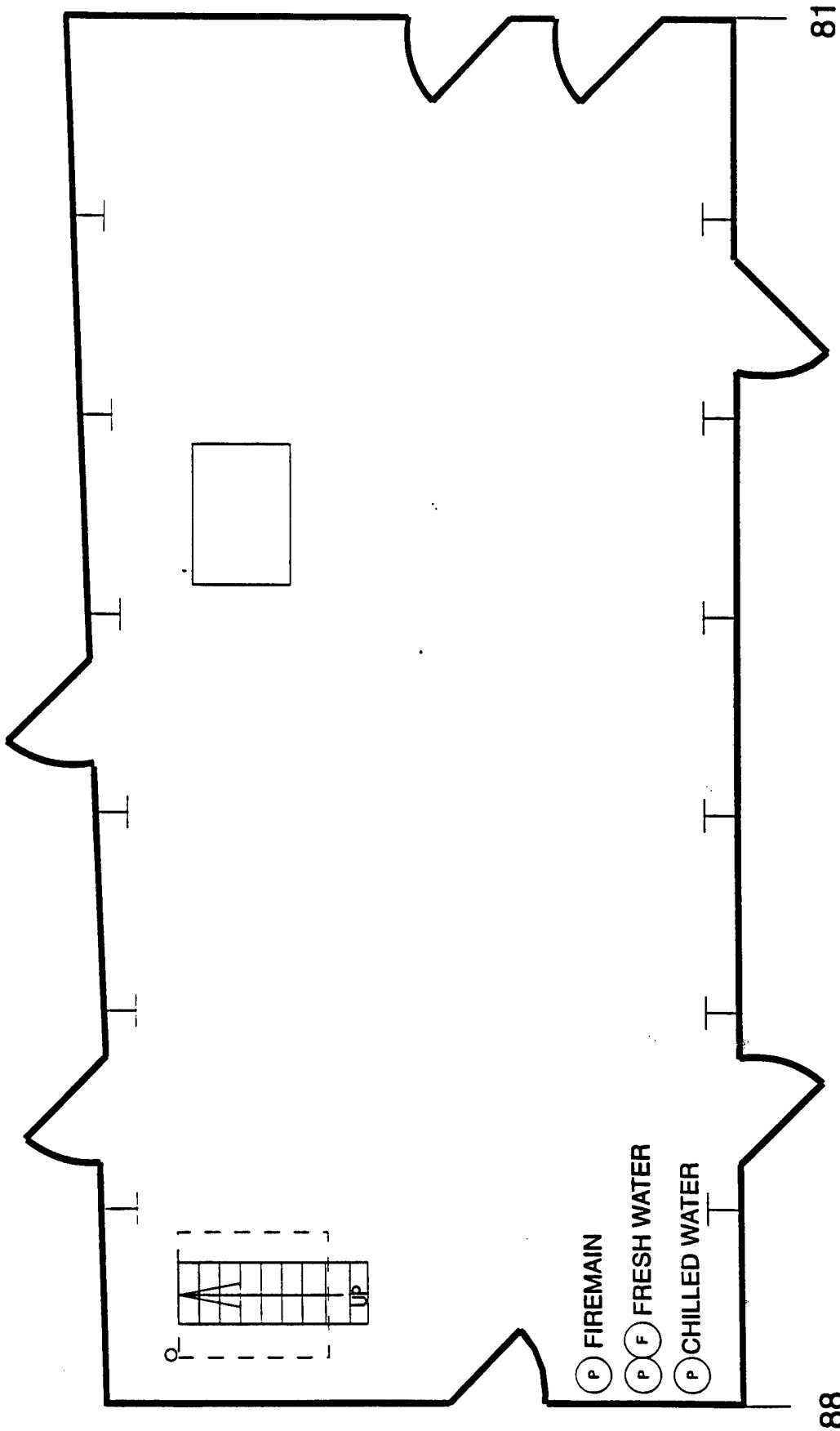

2ND PLATFORM	REV: 7/5/95
FILE: SUB2-88	DATE: 4/19/94

Fig. A6 – Wardroom instrumentation layout

FM RISER
2-88-4

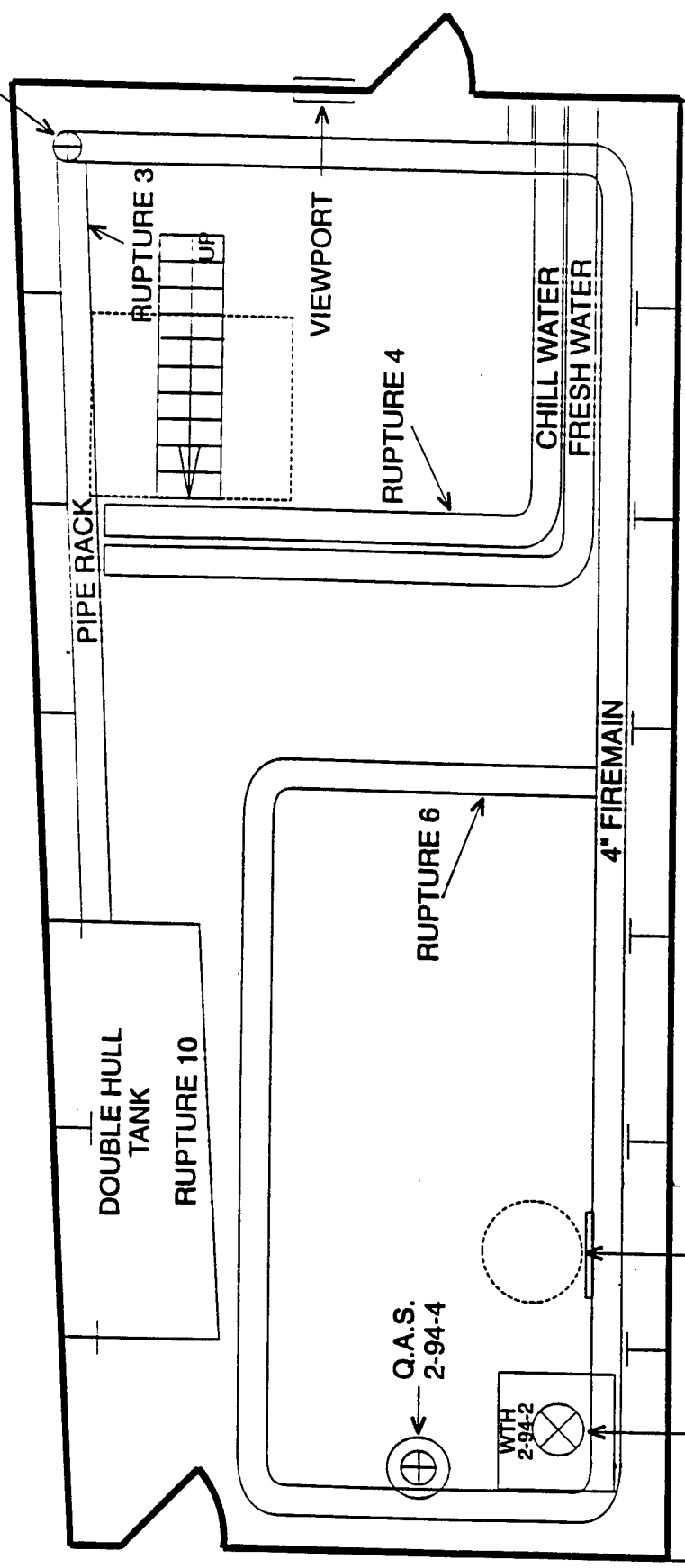

88

2ND PLATFORM	REV: 7/6/95
FILE: SUB2-95	DATE: 4/19/94

Q.A.S.
1-93-2

Q.A.S.
2-94-2

95

Fig. A7 - Upper wet compartment instrumentation layout

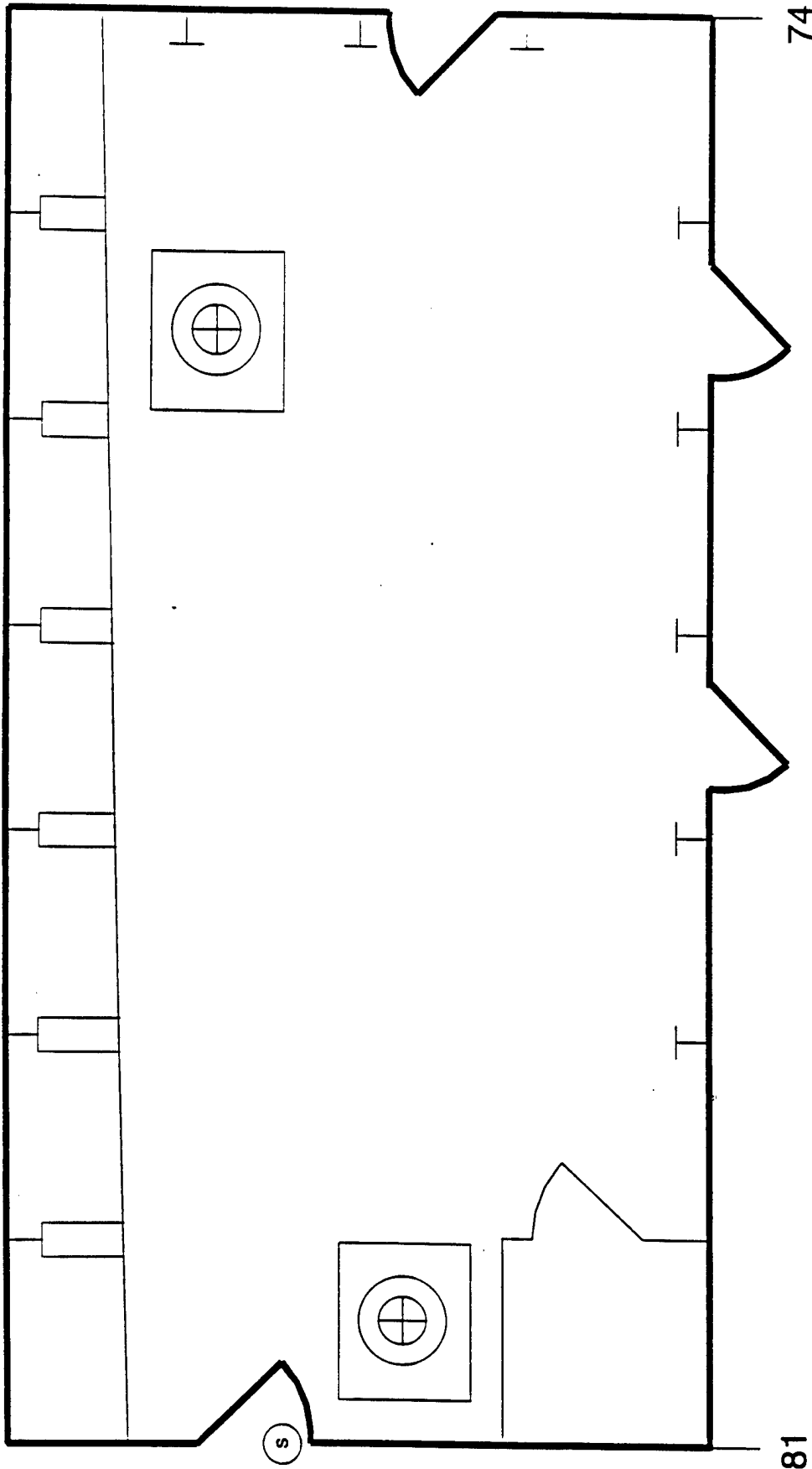

3RD PLATFORM	REV: 7/5/95
FILE: SUB3-81	DATE: 4/19/94

Fig. A8 – Torpedo room instrumentation layout

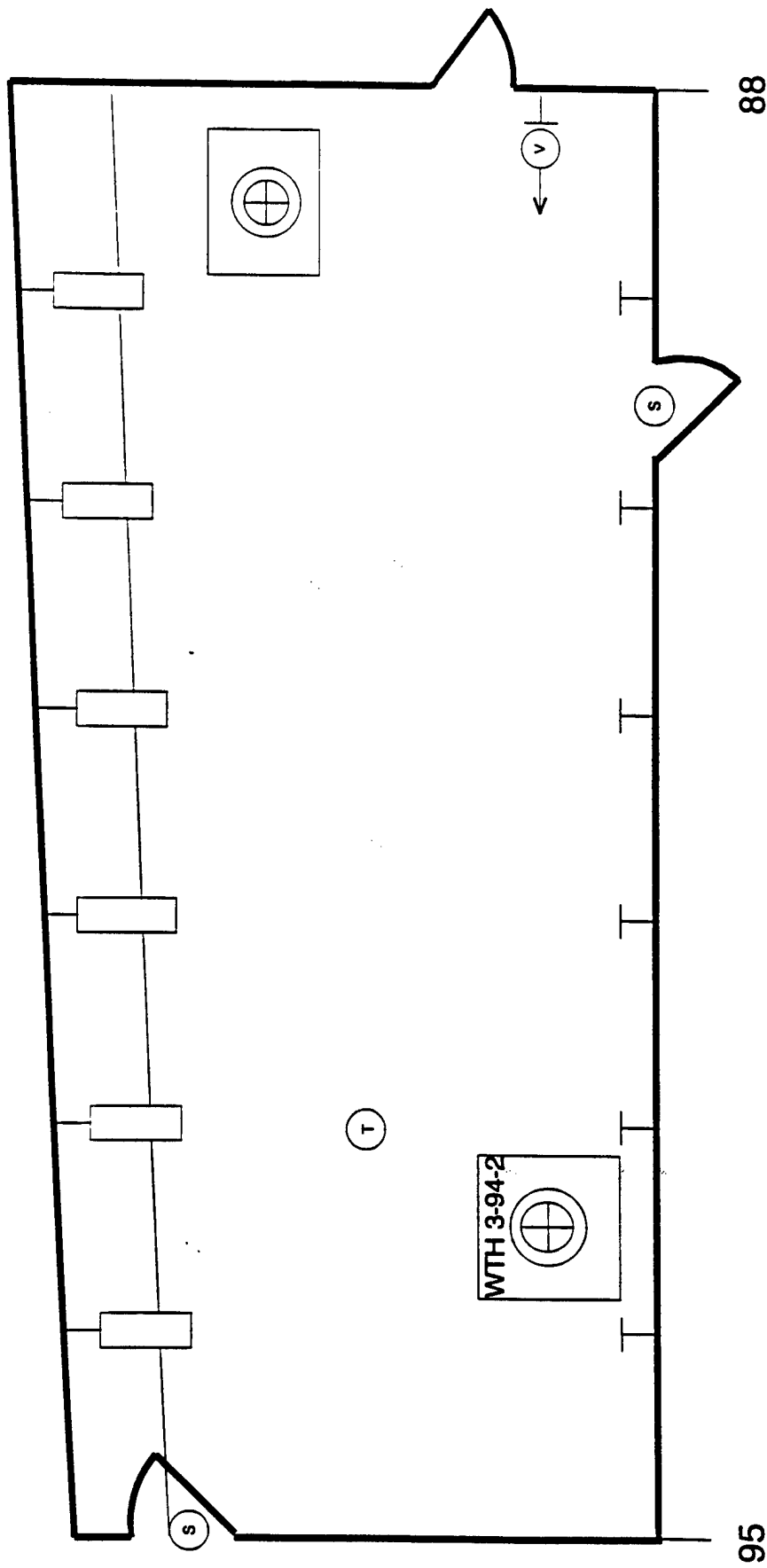

3RD PLATFORM	REV: 7/5/95
FILE: SUB3-95	DATE: 4/19/94

Fig. A9 -- Lower wet compartment instrumentation layout

Appendix B
Instrumentation Listing

INSTRUMENTATION LISTING - Damage Control Testing

[Note: For coordinate system (x/y/z), measurements are from: aft bulkhead/starboard bulkhead/deck level, within each space (exempt Bridge Access Trunk and Bilge level spaces). "+" is forward, port, up. All dimensions are in meters.]

Item No.	Instrument Description	Output Range	Location		REMARKS
			(x/y/z)	Frame No.	
CONTROL ROOM (1-81-2)					
1	Microswitch	0-1	QAWTD 1-85-2		Attach to WTD frame such that; open = 0, closed = 1
2	Microswitch	0-1	QAWTD 1-88-2		Attach to WTD frame such that; open = 0, closed = 1
FAN ROOM (1-88-2)					
3	Microswitch	0-1	QAWTH 1-89-2		Attach to WTH frame such that; open = 0, closed = 1
4	Microswitch	0-1	QAWTD 1-95-2		Attach to WTD frame such that; open = 0, closed = 1
PASSAGEWAY (2-68-2)					
5	Video (camera)	N/A	2.5/0.0/2.0	2-77-1	Mount high on inboard bulkhead, looking aft at Repair 4 doorway.
6	Audio (microphone)	N/A	5.0/2.5/2.5	2-70-0	Mount in overhead such that it does not interfere with personnel movement.
CREW LIVING (2-74-2)					
7	Microswitch	0-1	QAWTD 2-81-4		Attach to WTD frame such that; open = 0, closed = 1
UPPER "WET" COMPARTMENT (2-88-2)					
8	Video (camera)	N/A	8.5/1.0/2.0	2-88-1	Mount high on forward bulkhead, toward inboard side, looking at aft-centerline. Camera must be enclosed/protected from water spray.
9	Flow Meter	0-15 l/s (0-238 gpm)	8.6/1.0/2.0	"	Actually mounted <u>OUTSIDE</u> compartment on chill water supply piping. Turbine flow meter.
10	Pressure	0-1500 kPa (0-218 psi)	8.6/1.0/2.2	"	Actually mounted <u>OUTSIDE</u> compartment in chill water supply piping.

INSTRUMENTATION LISTING - Damage Control Testing

[Note: For coordinate system (x/y/z), measurements are from: aft bulkhead/starboard bulkhead/deck level, within each space (exempt Bridge Access Trunk and Bilge level spaces). " + " is forward, port, up. All dimensions are in meters.]

Item No.	Instrument Description	Output Range	Location		REMARKS
			(x/y/z)	Frame No.	
11	Flow Meter	0-15 l/s (0-238 gpm)	8.6/1.0/2.0	"	Actually mounted <u>OUTSIDE</u> compartment on firemain supply piping. Ultrasonic meter will be "strapped" to pipe.
12	Pressure	0-1500 kPa (0-218 psi)	8.6/1.0/2.2	"	Actually mounted <u>OUTSIDE</u> compartment in firemain supply piping.
13	Video (camera - Wide Angle Lens req'd)	N/A	5.0/0.0/2.0	2-91-1	Mount high on inboard bulkhead, looking across compartment in the "aft" direction. Camera must be enclosed/protected from water spray.
14	Thermocouple	0-100°C	0.1/3.3/2.1	2-95-2	Use <u>EXISTING</u> T/C string.
15	"	"	0.1/3.3/1.8	"	"
16	"	"	0.1/3.3/1.5	"	"
17	"	"	0.1/3.3/1.2	"	"
18	"	"	0.1/3.3/0.9	"	"
19	"	"	0.1/3.3/0.6	"	"
20	"	"	0.1/3.3/0.3	"	"
21	Audio (microphone)	N/A	1.0/1.5/2.5	2-94-0	Mount in overhead such that it does not interfere with personnel movement. Must be protected from water spray.
22	Video (camera - Wide Angle Lens req'd)	N/A	0.0/0.1/2.0	2-94-2	Mount high at the junction (corner) of the inboard and aft bulkheads, looking (forward) toward the center of the compartment. Camer must be enclosed/protected from water spray.

INSTRUMENTATION LISTING - Damage Control Testing

[Note: For coordinate system (x/y/z), measurements are from: aft bulkhead/starboard bulkhead/deck level, within each space (exempt Bridge Access Trunk and Bilge level spaces). "+" is forward, port, up. All dimensions are in meters.]

Item No.	Instrument Description	Output Range	Location		REMARKS
			(x/y/z)	Frame No.	
DC SHOP (2-95-4)					
23	Video (camera)	N/A	0.0/1.5/2.0	2-99-0	Mount high on aft bulkhead, near centerline. Looking forward at QAWTD 2-95-2.
24	Audio (microphone)	N/A	2.5/1.5/2.5	2-97-0	Mount in overhead such that it does not interfere with personnel movement.
TORPEDO ROOM (3-74-2)					
25	Microswitch	0-1	QAWTD 3-81-2		Attach to WTD frame such that; open = 0, closed = 1
LOWER "WET" COMPARTMENT (3-88-2)					
26	Video (camera - Wide Angle Lens req'd)	N/A	8.5/1.0/2.0	3-88-1	Mount high on forward bulkhead, near centerline, looking aft along centerline of compartment. Camera must be enclosed/protected from water spray.
27	Thermocouple	0-100°C	0.3/0.2/2.1	3-94-1	Aft T/C string.
28	"	"	0.3/0.2/1.8	"	"
29	"	"	0.3/0.2/1.5	"	"
30	"	"	0.3/0.2/1.2	"	"
31	"	"	0.3/0.2/0.9	"	"
32	"	"	0.3/0.2/0.6	"	"
33	"	"	0.3/0.2/0.3	"	"
34	Microswitch	0-1	QAWTD 3-89-2		Attach to WTD frame such that; open = 0, closed = 1

INSTRUMENTATION LISTING - Damage Control Testing

[Note: For coordinate system (x/y/z), measurements are from: aft bulkhead/starboard bulkhead/deck level, within each space (exempt Bridge Access Trunk and Bilge level spaces). "+" is forward, port, up. All dimensions are in meters.]

Item No.	Instrument Description	Output Range	Location		REMARKS
			(x/y/z)	Frame No.	
35	Microswitch	0-1	QAWTD 3-95-2		Attach to WTD frame such that; open = 0, closed = 1
STERN GATE MACHINERY ROOM (3-100-2)					
36	Microswitch	0-1	QAWTD 3-101-2		Attach to WTD frame such that; open = 0, closed = 1
PORT WING WALL - WEATHER DECK					
37	Flow Meter	0-15 l/s (0-238 gpm)	N/A	1-80-2	Install ("strap") Ultrasonic meter to firemain supply pipe, at main deck level. Piping located inside "combat systems" (sub) space.
38	Pressure	0-1500 kPa (0-218 psi)	"	"	Install in firemain supply piping at main deck level. Locate adjacent to item #38.
39	Video (camera)	N/A	N/A	1-58-2	Install such that forward access to "combat systems" (sub) space (QAWTD 1-75-2) is in view. Camera must be installed such that it does not interfere with normal personnel "traffic". Camera must be enclosed/protected from weather (or temporary/daily mount).
40	"	"	"	1-110-2	Install such the aft access to "fan room" (sub) (QAWTD 1-95-2) is in view. Camera must be installed such that it does not interfere with normal personnel "traffic". Camera must be enclosed/protected from weather (or temporary/daily mount).
STARBOARD WING WALL - WEATHER DECK					
41	Flow Meter	0-15 l/s (0-238 gpm)	N/A	1-80-1	Install ("strap") Ultrasonic meter to firemain supply pipe, at main deck level.
42	Pressure	0-1500 kPa (0-218 psi)	"	"	Install in firemain supply piping at main deck level. Locate adjacent to item #41.

INSTRUMENTATION LISTING - Damage Control Testing

[Note: For coordinate system (x/y/z), measurements are from: aft bulkhead/starboard bulkhead/deck level, within each space (exempt Bridge Access Trunk and Bilge level spaces). "+" is forward, port, up. All dimensions are in meters.]

Item No.	Instrument Description	Output Range	Location		REMARKS
			(x/y/z)	Frame No.	
43	Video (camera)	N/A	N/A	1-58-1	Install on inboard side of wing wall, looking aft and down into well deck area, focused in the vicinity of the access to the lower wet compartment (QAWTD 3-89-1). Camera must be enclosed/protected from weather (or temporary/daily mount).
44	Video (camera - Wide Angle Lens req'd)	"	"	1-101-1	Install on inboard side of wing wall, looking slightly aft and down into well deck, foicused in the vicinity of the "double hull" mock-up. Camera must be enclosed/protected from weather (or temporary/daily mount).
45	Video (camera)	"	"	Mast	Install on mast, looking aft into well deck area.

Appendix C
Original Test Schedule

May 18 (Day one)

- 1-01 Location 2-88-2-L (Rupture 3, 4" Firemain) pipe wrench with banding kit
- 1-02 Location 3-88-2-L I shore (wood) on WTH 3-94-2
- 1-03 Location 2-88-2-L (Rupture 3, 2" Firemain) pipe wrench with banding kit
- 1-04 Location 3-88-2-L I shore (metal and wood) on WTH 3-94-2
- 1-05 Location 1-88-2-Q (Fan Room) P-100 with foot valve/strainer
- 1-06 Location 2-88-2-L (Rupture 3, 2" Firemain) Jubilee patch
- 1-07 Location 3-88-2-L K shore (wood) on outboard bulkhead at frame 92
- 1-08 Location 2-88-2-L (Rupture 6, 3" Firemain) pipe wrench with banding kit
- 1-09 Location 3-88-2-L K shore (metal and wood) on outboard bulkhead at frame 92
- 1-10 Location 1-88-2-Q (Fan Room) P-250 pump with foot valve/strainer

May 19 (Day two).

- 2-01 Location 1-88-2-Q (Fan Room) P-250 with 2-1/2 in. eductor
- 2-02 Location 2-88-2-Q (Rupture 6, 3" Firemain) Jubilee patch
- 2-03 Location 3-88-2-L K shore (metal and wood) on outboard bulkhead at frame 92
- 2-04 Location 2-88-2-Q (Rupture 3, 4" Firemain) Jubilee patch
- 2-05 Location 3-88-2-L K shore (wood) on outboard bulkhead at frame 92
- 2-06 Location 1-88-2-Q (Fan Room) electrical submersible pump
- 2-07 Location 2-88-2-Q (Rupture 4, 2" Chill Water) pipe wrench with banding kit
- 2-08 Location 3-88-2-L I shore (wood) on WTH 3-94-2
- 2-09 Location 2-88-2-Q (Rupture 4, 2" Chill Water) pipe wrench with banding kit
- 2-10 Location 3-88-2-L I shore (metal and wood) on WTH 3-94-2
- 2-11 Location 1-88-2-Q (Fan Room) P-100 with 1-1/2 in. eductor

May 20 (Day three)

- 3-01 Location 2-88-2-Q (Rupture 3, 4" Firemain) Jubilee patch
- 3-02 Location 3-88-2-L I shore (metal and wood) on WTH 3-94-2
- 3-03 Location 2-88-2-Q (Rupture 3, 4" Firemain) Jubilee patch
- 3-04 Location 3-88-2-L I shore (wood) on WTH 3-94-2
- 3-05 Location 1-88-2-Q (Fan Room) electrical submersible pump
- 3-06 Location 2-88-2-Q (Rupture 3, 2" Firemain) Jubilee patch
- 3-07 Location 3-88-2-L K shore (metal and wood) on outboard bulkhead at frame 92
- 3-08 Location 2-88-2-Q (Rupture 3, 4" Firemain) pipe wrench with banding kit
- 3-09 Location 3-88-2-L K shore (wood) on outboard bulkhead at frame 92
- 3-10 Location 1-88-2-Q (Fan Room) P-250 with 2-1/2 in. eductor

May 22 (Day four)

- 4-01 Location 1-88-2-Q (Fan Room) P-100 with 1-1/2 in. eductor
- 4-02 Location 2-88-2-Q (Rupture 4, 2" Chill Water) pipe wrench with banding kit
- 4-03 Location 2-88-2-L Hull repair explosion rupture (Rupture 10) bucket patch
- 4-04 Location 2-88-2-Q (Rupture 6, 3" Firemain) pipe wrench with banding kit
- 4-05 Location 2-88-2-L Hull repair explosion rupture (Rupture 10) plugs and wedges
- 4-06 Location 1-88-2-Q (Fan Room) P-250 with foot valve/strainer
- 4-07 Location 2-88-2-Q (Rupture 3, 2" Firemain) pipe wrench with banding kit
- 4-08 Location 2-88-2-L Hull repair implosion rupture (Rupture 10) plugs and wedges
- 4-09 Location 2-88-2-Q (Rupture 4, 2" Chill Water) Jubilee patch
- 4-10 Location 2-88-2-L Hull repair implosion rupture (Rupture 10) bucket patch
- 4-11 Location 1-88-2-Q (Fan Room) P-100 with 1-1/2 in. eductor

May 23 (Day five)

- 5-01 Location 2-88-2-Q (Rupture 4, 2" Chill Water) Jubilee patch
- 5-02 Location 2-88-2-L Hull repair implosion rupture (Rupture 10) bucket patch
- 5-03 Location 2-88-2-Q (Rupture 3, 2" Firemain) Jubilee patch
- 5-04 Location 2-88-2-L Hull repair explosion rupture (Rupture 10) bucket patch
- 5-05 Location 1-88-2-Q (Fan Room) P-100 with 1-1/2 in. eductor
- 5-06 Location 2-88-2-Q (Rupture 6, 3" Firemain) Jubilee patch
- 5-07 Location 2-88-2-L Hull repair implosion rupture (Rupture 10) plugs and wedges
- 5-08 Location 2-88-2-Q (Rupture 4, 2" Chill Water) pipe wrench with banding kit
- 5-09 Location 2-88-2-L Hull repair explosion rupture (Rupture 10) plugs and wedges
- 5-10 Location 1-88-2-Q (Fan Room) P-250 with foot valve/strainer

May 24 (Day six)

- 6-01 Location 1-88-2-Q (Fan Room) electrical submersible pump
- 6-02 Location 2-88-2-Q (Rupture 3, 2" Firemain) pipe wrench with banding kit
- 6-03 Location 2-88-2-L Hull repair explosion rupture (Rupture 10) plugs and wedges
- 6-04 Location 2-88-2-Q (Rupture 6, 3" Firemain) pipe wrench with banding kit
- 6-05 Location 2-88-2-L Hull repair implosion rupture (Rupture 10) plugs and wedges
- 6-06 Location 1-88-2-Q (Fan Room) P-250 with foot valve/strainer
- 6-07 Location 2-88-2-Q (Rupture 3, 4" Firemain) Jubilee patch
- 6-08 Location 2-88-2-L Hull repair implosion rupture (Rupture 10) bucket patch
- 6-09 Location 2-88-2-Q (Rupture 3, 2" Firemain) pipe wrench with banding kit
- 6-10 Location 2-88-2-L Hull repair explosion rupture (Rupture 10) bucket patch
- 6-11 Location 1-88-2-Q (Fan Room) P-250 with 2-1/2 in. eductor

Appendix D
Actual Test Schedule

May 18 (Day one)

- 2-07 Location 2-88-2-Q (Rupture 4, 2" Chill Water) pipe wrench with banding kit
- 2-08 Location 3-88-2-L I shore (wood) on WTH 3-94-2
- 2-11 Location 1-88-2-Q (Fan Room) P-100 with 1-1/2 in. eductor
- 2-10 Location 3-88-2-L I shore (metal and wood) on WTH 3-94-2
- 2-01 Location 1-88-2-Q (Fan Room) P-250 with 2-1/2 in. eductor
- 2-02 Location 2-88-2-Q (Rupture 6, 3" Firemain) Jubilee patch
- 2-03 Location 3-88-2-L K shore (metal and wood) on outboard bulkhead at frame 92
- 2-04 Location 2-88-2-Q (Rupture 3, 4" Firemain) Jubilee patch
- 2-05 Location 3-88-2-L K shore (wood) on outboard bulkhead at frame 92
- 2-06 Location 1-88-2-Q (Fan Room) electrical submersible pump

May 19 (Day two)

- 2-09 Location 2-88-2-Q (Rupture 4, 2" Chill Water) pipe wrench with banding kit
- 1-02 Location 3-88-2-L I shore (wood) on WTH 3-94-2
- 1-06 Location 2-88-2-L (Rupture 3, 2" Firemain) Jubilee patch
- 1-04 Location 3-88-2-L I shore (metal and wood) on WTH 3-94-2
- 1-05 Location 1-88-2-Q (Fan Room) P-100 with foot valve/strainer
- 1-01 Location 2-88-2-L (Rupture 3, 4" Firemain) pipe wrench with banding kit
- 1-07 Location 3-88-2-L K shore (wood) on outboard bulkhead at frame 92
- 1-08 Location 2-88-2-L (Rupture 6, 3" Firemain) pipe wrench with banding kit
- 1-09 Location 3-88-2-L K shore (metal and wood) on outboard bulkhead at frame 92
- 1-03 Location 2-88-2-L (Rupture 3, 2" Firemain) pipe wrench with banding kit
- 1-10 Location 1-88-2-Q (Fan Room) P-250 pump with foot valve/strainer

May 20 (Day three)

- 3-01 Location 2-88-2-Q (Rupture 3, 4" Firemain) Jubilee patch
- 3-02 Location 3-88-2-L I shore (metal and wood) on WTH 3-94-2
- 3-03 Location 2-88-2-Q (Rupture 3, 4" Firemain) Jubilee patch
- 3-04 Location 3-88-2-L I shore (wood) on WTH 3-94-2
- 3-05 Location 1-88-2-Q (Fan Room) electrical submersible pump
- 3-06 Location 2-88-2-Q (Rupture 3, 2" Firemain) Jubilee patch
- 3-07 Location 3-88-2-L K shore (metal and wood) on outboard bulkhead at frame 92
- 3-08 Location 2-88-2-Q (Rupture 3, 4" Firemain) pipe wrench with banding kit
- 3-09 Location 3-88-2-L K shore (wood) on outboard bulkhead at frame 92
- 2-07-2 Location 2-88-2-Q (Rupture 4, 2" Chill Water) pipe wrench with banding kit
- 3-10 Location 1-88-2-Q (Fan Room) P-250 with 2-1/2 in. eductor

May 22 (Day four)

- 1-06-2 Location 2-88-2-L (Rupture 3, 2" Firemain) Jubilee patch
- 4-03 Location 2-88-2-L Hull repair explosion rupture (Rupture 10) bucket patch
- 3-10-2 Location 1-88-2-Q (Fan Room) P-250 with 2-1/2 in. eductor
- 4-02 Location 2-88-2-Q (Rupture 4, 2" Chill Water) pipe wrench with banding kit
- 4-05 Location 2-88-2-L Hull repair explosion rupture (Rupture 10) plugs and wedges
- 4-01 Location 1-88-2-Q (Fan Room) P-100 with 1-1/2 in. eductor
- 4-04 Location 2-88-2-Q (Rupture 6, 3" Firemain) pipe wrench with banding kit
- 4-07 Location 2-88-2-Q (Rupture 3, 2" Firemain) pipe wrench with banding kit
- 4-08 Location 2-88-2-L Hull repair implosion rupture (Rupture 10) plugs and wedges
- 4-06 Location 1-88-2-Q (Fan Room) P-250 with foot valve/strainer
- 4-09 Location 2-88-2-Q (Rupture 4, 2" Chill Water) Jubilee patch
- 4-10 Location 2-88-2-L Hull repair implosion rupture (Rupture 10) bucket patch
- 4-11 Location 1-88-2-Q (Fan Room) P-100 with 1-1/2 in. eductor

May 23 (Day five)

- 4-02-2 Location 2-88-2-Q (Rupture 4, 2" Chill Water) pipe wrench with banding kit
- 5-01 Location 2-88-2-Q (Rupture 4, 2" Chill Water) Jubilee patch
- 5-02 Location 2-88-2-L Hull repair implosion rupture (Rupture 10) bucket patch
- 5-05 Location 1-88-2-Q (Fan Room) P-100 with 1-1/2 in. eductor
- 5-03 Location 2-88-2-Q (Rupture 3, 2" Firemain) Jubilee patch
- 5-04 Location 2-88-2-L Hull repair explosion rupture (Rupture 10) bucket patch
- 5-06 Location 2-88-2-Q (Rupture 6, 3" Firemain) Jubilee patch
- 5-07 Location 2-88-2-L Hull repair implosion rupture (Rupture 10) plugs and wedges
- 5-08 Location 2-88-2-Q (Rupture 4, 2" Chill Water) pipe wrench with banding kit
- 5-09 Location 2-88-2-L Hull repair explosion rupture (Rupture 10) plugs and wedges
- 5-10 Location 1-88-2-Q (Fan Room) P-250 with foot valve/strainer

May 24 (Day six)

- 6-02 Location 2-88-2-Q (Rupture 3, 2" Firemain) pipe wrench with banding kit
- 6-03 Location 2-88-2-L Hull repair explosion rupture (Rupture 10) plugs and wedges
- 6-01 Location 1-88-2-Q (Fan Room) electrical submersible pump
- 6-04 Location 2-88-2-Q (Rupture 6, 3" Firemain) pipe wrench with banding kit
- 6-05 Location 2-88-2-L Hull repair implosion rupture (Rupture 10) plugs and wedges
- 6-06 Location 1-88-2-Q (Fan Room) P-250 with foot valve/strainer
- 6-07 Location 2-88-2-Q (Rupture 3, 4" Firemain) Jubilee patch
- 6-08 Location 2-88-2-L Hull repair implosion rupture (Rupture 10) bucket patch
- 6-09 Location 2-88-2-Q (Rupture 3, 2" Firemain) pipe wrench with banding kit
- 6-10 Location 2-88-2-L Hull repair explosion rupture (Rupture 10) bucket patch
- 6-11 Location 1-88-2-Q (Fan Room) P-250 with 2-1/2 in. eductor
- 2-04-2 Location 2-88-2-Q (Rupture 3, 4" Firemain) Jubilee patch
- 2-02-2 Location 2-88-2-Q (Rupture 6, 3" Firemain) Jubilee patch