

VOLUME 76

SEPARATE No. 27

PROCEEDINGS

AMERICAN SOCIETY
OF
CIVIL ENGINEERS

AUGUST, 1950

NAVY RESEARCH SECTION
SCIENCE DIVISION
REFERENCE DEPARTMENT
LIBRARY OF CONGRESS



4
APR 27 1951

Brown
Division
60
1950

U2790

PLASTICITY OF METALS—MATHEMATI-
CAL THEORY AND STRUCTURAL
APPLICATIONS

By D. C. Drucker, Assoc. M. ASCE

19961230 102

D710 QUALITY INSPECTED

STRUCTURAL DIVISION

Headquarters of the Society
33 W. 39th St.
New York 18, N.Y.

PRICE \$0.50 PER COPY

APPROVED FOR PUBLICATION
BY THE BOARD OF DIRECTORS
OF THE AMERICAN SOCIETY OF CIVIL ENGINEERS

*The Society is not responsible for any statement made or opinion expressed
in its publications*

Published at Prince and Lemon Streets, Lancaster, Pa., by the American Society of
Civil Engineers. Editorial and General Offices at 33 West Thirty-ninth Street,
New York 18, N. Y. Reprints from this publication may be made on
condition that the full title of paper, name of author, page
reference, and date of publication by the Society are given.

*Copyright 1950 by the AMERICAN SOCIETY OF CIVIL ENGINEERS
Printed in the United States of America*

AMERICAN SOCIETY OF CIVIL ENGINEERS

Founded November 5, 1852

PAPERS

PLASTICITY OF METALS—MATHEMATICAL
THEORY AND STRUCTURAL
APPLICATIONS

BY D. C. DRUCKER,¹ ASSOC. M. ASCE

SYNOPSIS

A brief analysis is given of the philosophy and practice of engineering design. The importance of plasticity in most elastic design is emphasized and the use of elementary plastic analysis is illustrated. Applications to beam and truss frameworks (limit design and "shakedown") and structural stability are discussed. The great difference between plasticity and nonlinear elasticity is shown by simple examples. A short description is given of the development of mathematical theories of plasticity and the experimental results on which they are based. The necessity for additional correlated experimental and analytical investigation is made apparent and the author's opinion of the initial direction this work should take is stated.

With the exception of the section which demonstrates that some members may unload when all loads applied to a structure increase in ratio, the paper presents a specialized survey and interpretation of existing information only.

ELASTIC DESIGN AND PLASTICITY

The usual civil engineering design apparently assumes completely elastic behavior. Working stresses are well below the elastic limit; internal stresses and accompanying deformations are computed from formulas such as

$$\sigma = \frac{M c}{I} \dots \dots \dots (1a)$$

and

$$\Delta = \frac{P L}{A E} \dots \dots \dots (1b)$$

—which are based on Hooke's law.

NOTE.—Written comments are invited for publication; the last discussion should be submitted by February 1, 1951.

¹Associate Prof., Eng., Brown Univ., Providence, R. I.

Elastic behavior seems to be postulated for main members and also for the welded or riveted connections that join them. Actually, however, as is well known, the usual specifications are based on the explicit or implicit requirement of high ductility. For example, the assumption of uniform distribution of load among rivets in a tension group is obviously in error in the elastic range where the end rivets take far more stress than their share. Stress concentrations produced by abrupt changes in section as from flange to web (shear) or by cover plates, rivet holes, cutouts of various kinds, welded connections for fixed-end beams, stiffeners, or bearing plates—in fact, just about all the real details of the distribution of stress—are ignored. Ductility or plastic deformation has the effect of smoothing out all these irregularities for static loading so that they can safely be forgotten. However, this elimination of the high spots does not happen until appreciable plastic deformation takes place; marked stress concentrations are usually present at working loads. Mechanical engineers especially have been forced to allow for them in design where there is danger of fatigue failure.

In some cases, plastic action is used directly to produce desired stresses or to keep stresses within the elastic range. Boiler tubes are expanded plastically by interior rolls to produce positive pressure between them and the plates through which they pass; cold rolled metal is used instead of hot rolled metal; shot peening is employed to induce residual surface compression and thus to reduce the danger of fatigue; and springs are pre-set.

Thus, closer examination shows that there is often little validity in the concept of purely elastic design. Plasticity is almost always important. This statement does not mean that elasticity is useless except where fatigue is important. On the contrary, practically all experience on actual structures and experimental data on structures, models, and components have been correlated with nominal (or elastic) stress calculations. Specifications are based on this accumulation of knowledge so that conventional designs for conventional structures must of necessity prove to be satisfactory.

For this very reason, if designs must be pushed to the limit to save material, or if the structure contains novel features, the usual specification may not provide an adequate guide. The resulting factor of safety may be excessive or too small. An experienced and extremely capable engineer may be able to extrapolate his knowledge correctly, but it is clear that a more formal and precise approach is desirable. The first question to be decided is what the structure is to be designed against; certainly not against elastic breakdown at any point, for the result would be a very uneconomical design which would not make proper use of the known value of ductility. Clearly there should be an adequate factor of safety against complete failure; but of much more importance when structural steel or aluminum is used is the factor of safety against the excessive deformation which generally occurs long before failure, sometimes of course in the elastic range as in ceiling beams. A simple tension member will certainly deform unduly in most applications when its yield strength is exceeded, but a beam or shaft usually does not deform too much when the extreme fiber yields. Similarly, the yielding of one member of a statically indeterminate truss or of one cross section of a statically indeterminate beam does not necessarily cause excessive deflection of the structure.

SIMPLE PLASTIC DESIGN

A number of interesting and technically important conclusions can be drawn from the consideration of a material termed ideally plastic, one which does not work harden but which yields and continues to flow under constant stress. Structural steel seems to be in this category at the beginning of the plastic range, but this phenomenon is illusory. Initial yielding is inhomogeneous; no part of the material has a strain given by a point in the practically flat part, C, of the stress-strain diagram (Fig. 1). Such a point denotes only the effect of averaging over the gage length some material which is elastic (point A) and some material which has slipped appreciably (point B). However, regardless of the physical validity of such a theory of ideal plasticity for a particular metal, it is simple and often indicates the answer for work-hardening metals.

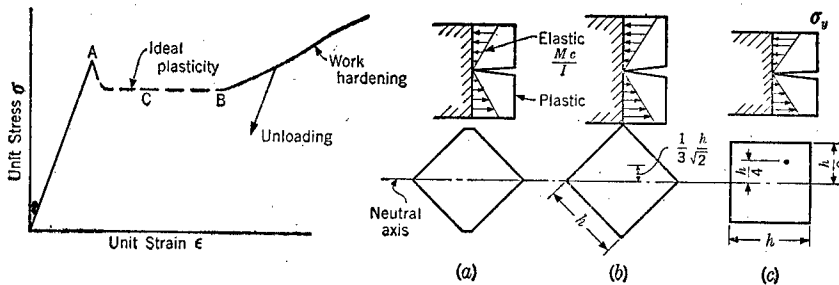

FIG. 1.—STRESS-STRAIN DIAGRAM FOR STRUCTURAL STEEL

FIG. 2.—COMPARISON OF ELASTIC AND PLASTIC PROPERTIES

Elastic: (a) Better Than (b); for Given Moment, Maximum Stress for (b) Is $\sqrt{2}$ Times That for (c). Ideally Plastic: (b) Better Than (a); Moment Capacity of (c) Only 6% More Than (b)

Some differences between elastic and plastic design show up strongly in the pure bending of a beam of square cross section and of a beam of modified square cross section (Fig. 2). The maximum stress, σ , produced by a pure moment M in an elastic beam is $M c/I$ in which c is the distance from the neutral axis to the extreme fiber and I is the moment of inertia about the neutral axis. The triangular tip of Fig. 2(b) contributes more to c than to I so that, for a given moment, the maximum stress in section (b) is higher than that in section (a). A much greater difference is found between sections (b) and (c) because I is the same for both but the values of c are in the ratio $\sqrt{2}$ to 1. In the (ideal) plastic range the maximum resisting moment for symmetric sections is twice the product of the yield stress, σ_y , the area between the neutral axis and one extreme fiber, and the distance of the centroid of the area from the neutral axis. The ratio for Fig. 2(b) to Fig. 2(c) is just the ratio of the centroidal distances or $3\sqrt{2}/4 = 1.06$ —a much smaller difference than in the elastic case. Now section (b) appears preferable to section (a).

LIMIT DESIGN

The advantage of considering the plastic region lies in the economy of design that becomes possible. It has long been advocated for both simple

cases and for statically indeterminate structures by J. A. Van den Broek, M. ASCE, under the designation, limit design.² Coupled with the assumption of ideal plasticity, the design is not only more efficient but the procedure is considerably simplified. The fixed-end beam under uniform load, Fig. 3(a), is a good example. Successive moment diagrams are shown for increasing values of load. In the elastic range and for an I-beam, almost until the end moments reach their limiting value M_L , the points of inflection remain the same and the end moment is numerically twice the center moment. Further increase in load after M_L is reached cannot increase the end moments because of the assumption of ideal plasticity. The center moment continues to rise until it too reaches M_L if the beam is of constant cross section. No additional load can then be supported. There is obviously no need to follow the process to calculate W_{max} . The diagram showing three plastic hinges, points at which $M = M_L$ or $-M_L$, enables direct computation.

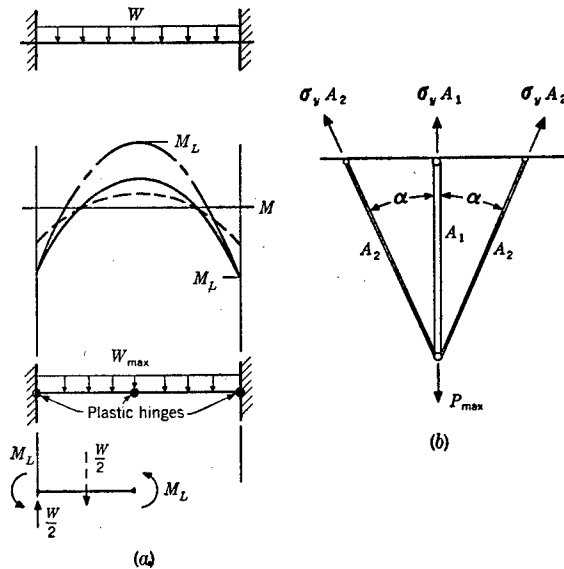

FIG. 3.—LIMIT DESIGN—IDEAL PLASTICITY ASSUMED

Similarly, in the case of the three tension bars, Fig. 3(b), there is no need to solve the statically indeterminate problem. The limit load is directly

$$P_{max} = \sigma_y A_1 + 2 \sigma_y A_2 \cos \alpha \dots \dots \dots (2)$$

in which σ_y is the flow stress. In the first case (and usually in the second), the limit load will be considerably larger than the load that causes plastic deformation to start.

As must be expected, the reduction of complicated problems to static determinacy involves a sacrifice. The deformation of the structure does not

² "Theory of Limit Design," by J. A. Van den Broek, John Wiley & Sons, Inc., New York, N. Y., 1948.

have to be considered explicitly. Conversely, the deformation is not calculated and there is always the most vital question of whether or not it is excessive and therefore the unsettled doubt exists as to the validity and the applicability of the assumption of ideal plasticity.

Alexander Hrennikoff, Assoc. M. ASCE, and others^{3,4} have studied this question by taking the actual stress-strain curve into account. Once this is done, and the details of plastic action are examined more closely, other serious limitations appear. No mention has been made of the shear in the plastic beam of Fig. 3(a). Neglecting it would not be serious if the beam were rectangular in cross section because of its necessarily small magnitude. On the contrary, in I-beams, or more especially plate girders, the web is designed for shear. It is relatively thin, and the shear stress value may be high, so high that plastic deformation will begin at the web-flange junction rather than at the extreme fiber (see Fig. 4).

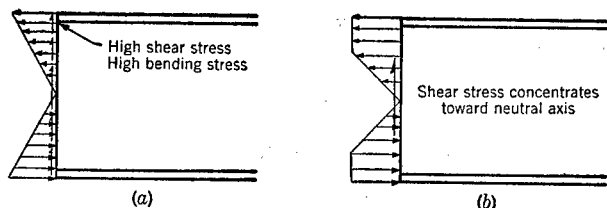

FIG. 4.—BENDING AND SHEAR

Furthermore, as plastic flow continues, the shear stress at the neutral axis increases and may well cause complete yielding of the section before the conventional limit load is reached. The answers to the foregoing questions require a much more complete theory of plasticity. In the subsequent discussion, it will be seen that, at present, the answers to many fundamental problems are still not known.

Most of these same unanswered queries do not apply to statically indeterminate trusses or to pin-connected frameworks. Each member is subjected to simple tension or compression and ideal plasticity is probably a good enough assumption. A limit design for a given loading would be a satisfactory answer. The straightforward approach is to apply the loading slowly as given, determine which member yields first, increase the loading, and find the next member to yield, continuing the process until enough members have yielded to cause failure. This process may well be tedious as it involves at least one, and possibly many, solutions of statically indeterminate elastic problems. A short cut should be found. In some cases it will be apparent which bars will yield to cause failure and the laborious calculations can be replaced by a simple statics computation. In many cases, however, there will be a few reasonable alternatives and some set procedure is required for deciding which of the statics computations is correct. H. J. Greenberg has proved the statement of S. M.

³ "Theory of Inelastic Bending with Reference to Limit Design," by Alexander Hrennikoff, *Transactions, ASCE*, Vol. 113, 1948, pp. 213-247.

⁴ "Ueber das Verhalten statisch unbestimmter Konstruktionen aus Stahl nach Ueberschreitung der Elastizitätsgrenze," by W. Prager, *Bauingenieur*, Vol. 14, 1933, pp. 65-67.

Feinberg⁵ that any body (and therefore a structure in particular) will support the maximum load that it possibly can. Failure will not occur if any stable system of forces exists in the bars that will satisfy the equations of equilibrium. This is an extension of the dictum by N. C. Kist.⁶

William Prager and P. S. Symonds, at Brown University in Providence, R. I., have re-examined the basic principles that must apply to structures. In addition to limit design they explored the interesting problem of "shakedown," which arises when a structure such as a railway bridge is subjected to loads that change in magnitude between fixed limits. Each panel point load is assumed to vary independently of all other loads in any manner between a low value and a high value any number of times. The problem is whether or not, if plastic deformation does occur at some loading, eventually the structure will adjust itself and never again yield anywhere in tension or compression.

Again, all the answers to this very practical problem are not yet known but an interesting and useful geometrical method is being applied.⁷ It may be illustrated by reference to the simple indeterminate structure of Fig. 3(b). Assume that the load P alters in magnitude, and possibly changes in sign, in any manner between $+P_{max}$ (tension) and P_{min} (compression). Calling

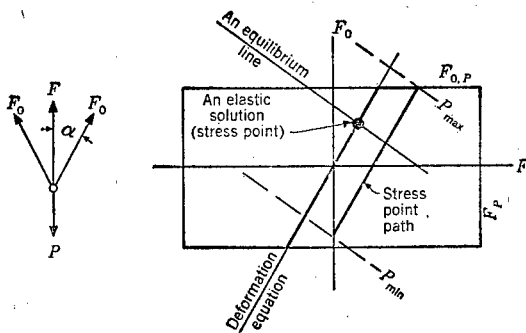

FIG. 5.—SHAKEDOWN

the force in the central bar F and the force in each of the outer bars F_o , Fig. 5, the equation of equilibrium is

$$P = F + 2 F_o \cos \alpha \dots \dots \dots (3)$$

In the elastic range, the second equation is determined by the deformation of the structure as

$$\frac{F L}{A E} = \frac{F_o L_o}{A_o E_o \cos \alpha} \dots \dots \dots (4a)$$

or

$$F_o = \left(\frac{A_o E_o L}{A E L_o \cos \alpha} \right) F \dots \dots \dots (4b)$$

A coordinate system with axes F and F_o shows the behavior of the structure. The deformation equation plots as a straight line through the origin, with slope

⁵ "The Principle of Limiting Stress," by S. M. Feinberg, *Prikladnaya Matematika i Mekhanika*, Vol. 12, 1948, p. 63-68.
⁶ "Theory of Limit Design," by J. A. Van den Broek, John Wiley & Sons, Inc., New York, N. Y., 1948, p. 39.
⁷ "Problem Types in the Theory of Perfectly Plastic Materials," by W. Prager, *Journal of the Aeronautical Sciences*, Vol. 15, 1948, pp. 337-341.

$\frac{A_o E_o L}{A E L_o} \cos \alpha$. The equation of equilibrium for a given value of P plots as a straight line with a negative slope $\frac{1}{2 \cos \alpha}$. The stress point or intersection of the two lines gives the solution F, F_o . As the tensile force P increases in magnitude, the equilibrium line does not change in slope but simply moves parallel to itself, and the stress point moves straight out. This peaceful state of affairs is rudely interrupted by the onset of plastic action: F cannot exceed F_P and F_o cannot exceed $F_{o,P}$ on the assumption of ideal plasticity. These limits plus those for compression form a yield rectangle and the stress point cannot go outside it. As the load increases, the stress point moves out along the deformation line, hits the yield line, and moves along it. Unloading, or reducing the load, brings the stress point back along a line parallel to the original deformation line. Whether or not the system will "shake down" is clear from the picture. It will shake down for values of P_{max} and P_{min} as shown; it would not for the values $P_{min} = -P_{max}$.

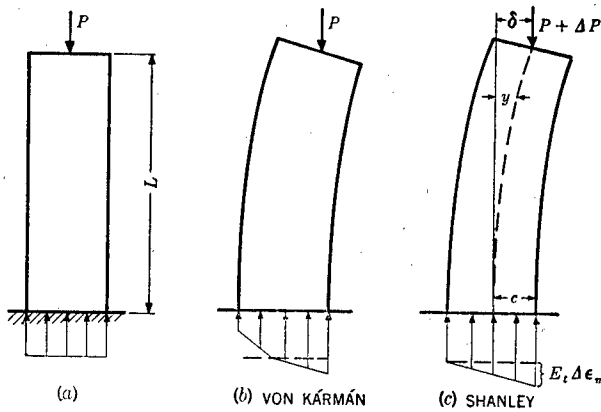

FIG. 6.—COLUMN INSTABILITY (PLASTIC)

In actual practice the structure will have several bars each with its own value of force F_n and the coordinates chosen are modified; $\frac{F_n}{\sqrt{2 A_n E/L_n}}$ would be used instead of F_n . The advantage is that the deformation line and the equilibrium line become perpendicular to each other in the elastic range. The distance from the origin to the stress point, $\frac{F_1^2}{2 A_1 E/L_1} + \frac{F_2^2}{2 A_2 E/L_2} + \dots$, is the elastic strain energy that must be a minimum for a given set of loads.

The same method may be used for the analysis of rigid frames and continuous beams on the limit design type of assumption.

STRUCTURAL STABILITY

For many years it was felt that the problem of stability of columns in the plastic work-hardening range was clearly understood in principle despite the

fact that predicted loads were often appreciably higher than those found experimentally. The method of analysis used was the same as that for elastic columns. In the latter case, the critical load is the load at which the equilibrium is neutral. Within the limitations of ordinary beam theory, at this load, no force is required to displace the column from its straight configuration; and, if displaced, the column will remain in the displaced position. The same procedure applied to the work-hardening range leads to formulas in which a reduced modulus occurs, a combination of elastic and plastic moduli.

As F. R. Shanley⁸ demonstrated in 1947, this method of attack does not take into account all possibilities, and so ignores the actual one. Consider a column of length L fixed at the bottom, free at the top (half of a hinged-end column) loaded centrally by a force P (see Fig. 6(a)). Instead of asking the question—"What happens if the top of the column is displaced at a given value of P (Fig. 6(b))?"—it is necessary to follow the loading process and to consider the possibility of deflection occurring as the load is increased (Fig. 6(c)). In the latter case there need not be unloading of any point in the column, and equilibrium may be maintained in the displaced position without a horizontal force applied to the column. The necessary conditions for such an occurrence for a small increment in load ΔP are that

$$\Delta P = 0.5 E_t \Delta \epsilon_m A \dots \dots \dots (5)$$

in which E_t is the plastic (tangent) modulus and $\Delta \epsilon_m$ is the maximum increment in strain. The column is here assumed symmetric in cross section. Moment equilibrium must also be satisfied so that

$$P \delta = \frac{0.5 E_t \Delta \epsilon_m I}{c} \dots \dots \dots (6a)$$

in which δ is the lateral deformation of the top of the member. In terms of the radius of curvature ρ ,

$$P \delta = \frac{E_t I}{\rho_{\max}} \dots \dots \dots (6b)$$

A similar equation must be satisfied at each cross section:

$$P (\delta - y) = \frac{E_t I}{\rho} \dots \dots \dots (7)$$

Eq. 7 is the same as the equation for elastic stability except that the tangent modulus appears instead of the elastic modulus. Therefore, when

$$P = \frac{\pi^2 E_t I}{4 L^2} \dots \dots \dots (8)$$

deflection can occur without application of horizontal forces providing P is increased by ΔP or more. However, if the load ΔP is added and the column is prevented from bending, $P + \Delta P$ does not make the column unstable. Horizontal motion without horizontal force requires still another increment in

⁸ "Inelastic Column Theory," by F. R. Shanley, *Journal of the Aeronautical Sciences*, Vol. 14, 1947, pp. 261-268.

load. This type of effect is instability only in the sense that two equilibrium positions are possible. Both are stable; positive work must be done to displace the column from either position. In practice, however, a column will not be found perfectly straight at loads greater than those given by substitution of the tangent modulus in the elastic buckling formulas. Nevertheless, large deflection (apparent buckling) may not occur until the load is appreciably above this initial value; but it will occur below the von Kármán value. Mr. Shanley's concept reopens the entire field of plastic buckling; all previous solutions must be re-examined. Many basic principles are still to be established.

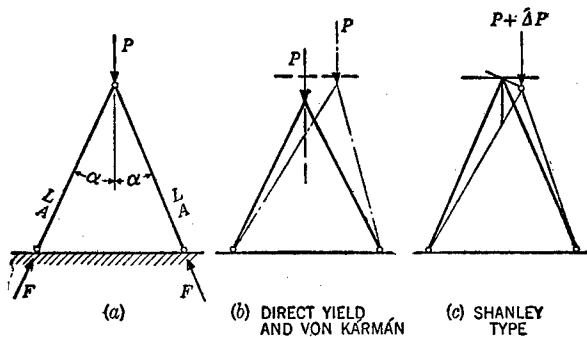

FIG. 7.—STRUCTURAL INSTABILITY (PLASTIC)

Another simple application to frameworks (Fig. 7) shows the differences between the old and new viewpoints. As the load P is increased, the bars become plastic but they work harden and will continue to carry additional load without failing. Failure may occur in several ways. The ultimate load is determined by the angle α and the shape of the stress-strain curve. When side motion of the apex is prevented, the system will collapse vertically at a load:

$$P = \frac{2 E_t A \cos^3 \alpha}{\sin^2 \alpha} \dots \dots \dots (9a)$$

No additional force is required to produce downward motion of the point of application at P . However, if

$$P = \frac{2 E_t A \sin^2 \alpha}{\cos \alpha} \dots \dots \dots (9b)$$

which has a much smaller value if α is less than 45° , no external horizontal force is needed to cause horizontal displacement of the apex (Shanley effect). However, an increment in P will be required as in the case of the column. This increment is not unique, it has its least value for the case in which one bar takes on no additional load but does not unload (Fig. 7(c)). To obtain the equivalent of a von Kármán instability load (Fig. 7(b)), it is necessary to write the condition that P remains constant as lateral motion takes place without horizontal force. One bar will be found to unload and the value of P required is larger than that when P is permitted to increase. Another possible

mode of failure—the Shanley type of buckling of the bars themselves—should also be considered.

MATHEMATICAL THEORIES OF PLASTICITY

The mathematical work required becomes more elaborate in the more complicated problems and is really formidable for general cases. It would be convenient to ignore them and avoid trouble. Unfortunately, determination of when deflections or stresses are excessive almost invariably involves plastic behavior. Beams or girders often fail by local web or over-all plastic buckling; and, as indicated in Fig. 4, the state of stress is not simple. At present, tests are relied on to supply the answers and no result can be as satisfactory as a careful test on the same structure or part. Tests are difficult, expensive, and time consuming, however. Extrapolation of results without an adequate theory is often misleading and tests covering all important cases are a physical impossibility.

Therefore, the next best procedure should be adopted: Develop as simple a theory as possible which will be adequate for the problems on hand. Its adequacy can be assured only by frequent experimental checks. It is by no means obvious which factors should be included and which omitted, and the final answer is still to be obtained. For example, time effects are customarily assumed to be ignored in structural and machine applications; but, when concrete is involved and the time is long, this assumption would not be reasonable.

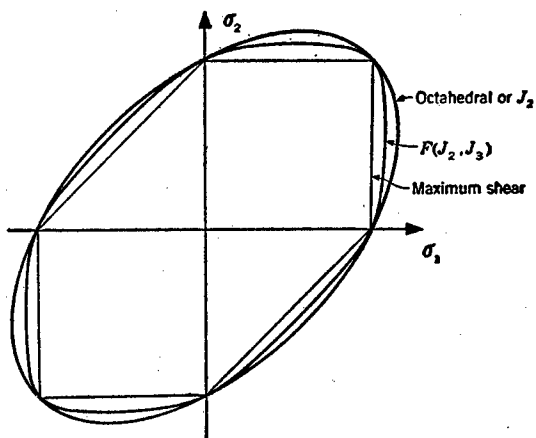

FIG. 8.—SEVERAL YIELD CRITERIA

that the point representing it moves outside. Fig. 8 shows a few simple criteria of yield or loading for two-dimensional stress, the octahedral shearing stress, the maximum shearing stress, and the more general function of shearing stress $f(J_2, J_3)$ (J_2 and J_3 being the second and third invariants of the stress devia-

Neglecting the time factor, it follows that at each stage in the plastic deformation some function of stress governs the continuing of the plastic action. In geometric language, yield or loading surfaces exist in stress space.^{9,10} At any stage in the plastic deformation, if the point representing the state of stress moves inside the surface, elastic action only occurs. For a material that has been work hardened, if plastic action is to result, the stress must change so

⁹ "Recent Developments in the Mathematical Theory of Plasticity," by William Prager, *Journal of Applied Physics*, March, 1949, pp. 235-241.

¹⁰ "The Significance of the Criterion for Additional Plastic Deformation of Metals," by D. C. Drucker, *Journal of Colloid Science* (rheology issue), Vol. 4, 1949, pp. 299-311.

tion¹¹ and J_2 being proportional to the square of the octahedral shearing stress). The yield surface, of course, is a yield curve in two dimensions. When there is no work hardening (ideal plasticity), if the stress point reaches the yield curve, flow occurs without limit for homogeneous states of stress. In work-hardened material, the stress point does move outside and the yield or the loading surface moves with it. A common but oversimple assumption is that the same variables still control. A larger value of the loading function is now required to continue plastic deformation—for example, a greater octahedral shearing stress equal to the largest one previously applied.

The concept of a loading function or of the variables that control plastic deformation is one facet of a mathematical theory of plasticity. Another is the actual form of the stress-strain relation. The simplest idea, and the one which has been used most extensively, is that stress and strain are uniquely related as long as loading continues (deformation theory). The stress-strain relation is then identical with the one for nonlinear elasticity except that on unloading a linear elastic recovery is assumed. One example of such equations for work-hardening material has the following typical expression for loading:

$$\epsilon_z = \frac{1}{C(\tau_o)} [\sigma_z - \nu'(\sigma_y + \sigma_x)] \dots \dots \dots (10)$$

in which $C(\tau_o)$ is a plastic modulus, a function of the octahedral shearing stress τ_o , and ν' denotes a plastic Poisson's ratio, often taken as 0.5. For unloading,

$$\Delta\epsilon_z = \frac{1}{E} [\Delta\sigma_z - \nu(\Delta\sigma_y + \Delta\sigma_x)] \dots \dots \dots (11)$$

in which ν is the elastic Poisson ratio and the symbols Δ indicate changes in stress, σ , and in strain, ϵ .

The solution of general problems by this most elementary deformation theory is very difficult and discourages attempts to improve theory. It is, therefore, a most unpleasant fact that any deformation theory generally has validity only in the rare and special case in which all stresses remain fixed in direction and merely increase in ratio. This particular case is precisely the one most commonly used in obtaining test data. A thin-walled tube is loaded by a combination of direct pull, internal pressure, and, sometimes, torsion—increased in ratio. Therefore, some confusion has developed and some improper applications of the deformation theory have been made. The inconsistency lies in the incompatibility of a quasi nonlinear elasticity and a yield or a loading function when all paths of loading are considered.

An incremental theory is required instead. There cannot be a unique relation between stress and strain and only one relation for the increment in strain in terms of the existing state and history and the changes in stress. The simplest example of this type of theory has as a typical expression—

$$d\epsilon_z = \frac{1}{E} [d\sigma_z - \nu(d\sigma_y + d\sigma_x)] + \frac{1}{C_1(\tau_o)} [\sigma_z - 0.5(\sigma_y + \sigma_x)] d\tau_o \dots (12)$$

¹¹ "Strain Hardening Under Combined Stresses," by W. Prager, *Journal of Applied Physics*, Vol. 16, 1945, pp. 837-840.

—the sum of an elastic and plastic strain increment. Consistency with an octahedral stress loading surface is assured because, if the octahedral shearing stress does not change, $d\tau_o = 0$, the increment in strain is purely elastic. Actually much more elaborate expressions are required to fit just a few of the observed important facts: The Bauschinger and allied effects and the Mohr circle comparison^{11,12} introduced by W. Lode. In tensor notation, using the summation convention, the most general form of incremental theory is

$$d\epsilon_{ij} = d\epsilon_{ij,e} + G \frac{\partial f}{\partial \sigma_{ij}} \frac{\partial f}{\partial \sigma_{kl}} d\sigma_{kl} \dots \dots \dots (13)$$

in which f (the loading function) and G are functions of stress, strain, and the history of stress and strain and $d\epsilon_{ij,e}$ is the increment in the elastic or recoverable strain.^{9,10} The loading function determines the incremental stress-strain law.

THE PATH OF LOADING

Another reason for the breakdown of the deformation type of theory, and the philosophy behind it, is illustrated simply by the familiar three-wire problem of elementary strength of materials (Fig. 9). This example shows the danger of wishful thinking. The deformation type of theory is applicable when the stress at each point increases in ratio; and, therefore, the hope was expressed that, if all loads applied to a body increase in ratio, the stresses will do likewise.¹³ The three-wire problem proves this hope to be vain. Many other simple counterexamples can be found. Not only do the stresses not necessarily go up in ratio but unloading may (and will) often take place locally.

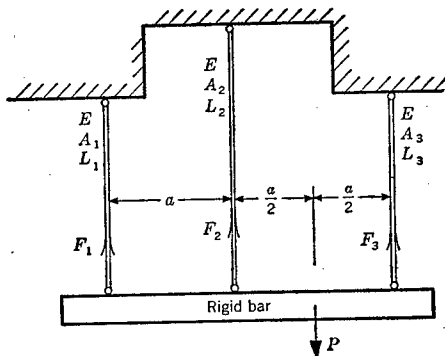

FIG. 9.—LOADING MAY PRODUCE LOCAL UNLOADING

It seems preferable to describe the solution in words first: In the elastic range, the load P applied to the rigid bar of Fig. 9 is divided by the three wires in accordance with their stiffness (spring constant) and the conditions of equilibrium. Assume the center wire to be strong but very flexible; imagine it temporarily, for this step only, as a rubber band. The outer two wires will both be stressed in tension. Despite the smaller load carried by the one on the left, this wire may yield first because its area is smaller.

As the load P increases further, the force in the center and right-hand wires will increase; and, if the areas are in proper ratio, the right-hand wire will yield next. On continued loading, the central wire, which is elastic, will act as a pivot, the rigid bar will rotate clockwise, and the left-hand wire will unload.

¹² "The Relation of Experiments to Mathematical Theories of Plasticity," by D. C. Drucker, *Journal of Applied Mechanics*, Vol. 16, 1949, pp. 349-357.

¹³ "The Theory of Elastic-Plastic Deformation and Its Applications," by A. A. Ilyushin, *Izvestia, Akademi Nauk U.S.S.R., Otdelenie Tekhnicheskikh Nauk*, 1948, pp. 769-788.

The preceding description applies equally well to ideal plasticity or to the usual work-hardening stress-strain curves. Depending on geometry, and the type of these curves, the system will perform various tricks. For example, if the wires are really work-hardening bars capable of taking compression, the left-hand one may be made to yield in tension, unload, load in compression, yield, and unload again as the load P increases steadily.

The mathematical proof of unloading produced by loading merely requires writing the equations of equilibrium and of deformation. The geometric representation appears as Fig. 10. At all times, for equilibrium,

$$F_1 + F_2 + F_3 = P \dots\dots\dots (14a)$$

and

$$3 F_1 + F_2 - F_3 = 0 \dots\dots\dots (14b)$$

In the elastic range,

$$\frac{F_1 L_1}{A_1 E} + \frac{F_3 L_3}{A_3 E} = 2 \frac{F_2 L_2}{A_2 E} \dots\dots\dots (15)$$

so that

$$F_1 = \frac{P \left(\frac{2 L_2}{A_2 E} - \frac{L_3}{A_3 E} \right)}{2 \left(\frac{L_1}{A_1 E} + \frac{4 L_2}{A_2 E} + \frac{L_3}{A_3 E} \right)} \dots\dots\dots (16)$$

will be tensile if $\frac{2 L_2}{A_2 E} > \frac{L_3}{A_3 E}$. For sufficiently small values of A_1 , F_1/A_1 will exceed the yield stress σ_y first (point A, Fig. 10); and, with the assumption of ideal plasticity, $F_1 = \sigma_y A_1$ then replaces the elastic deformation condition. As P increases, F_2 and F_3 increase equally and A_3 may be chosen to make bar 3 yield next point B (Fig. 10). At this stage, two bars have yielded but collapse does not occur because both have yielded in tension and the central bar is still elastic. The third equation is now $F_3 = \sigma_y A_3$ and direct calculation shows that F_1 must decrease as P increases further from point B to point C (Fig. 10).

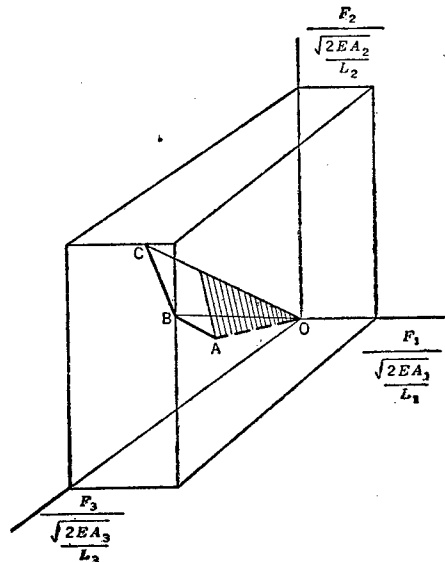

FIG. 10.—GEOMETRIC REPRESENTATION FOR THE THREE-WIRE PROBLEM

If a reasonable extension of the Saint Venant principle in plasticity is accepted (an unreasonable one being easy to make), the case of bending plus tension, of which the three-wire problem is really a particular case, exhibits this same phenomenon. The case of torsion shows that the stress pattern alters considerably from the elastic to the plastic state as loading proceeds, although unloading does not occur.

The combination of the probable change in the pattern of stress and the possibility of unloading occurring locally makes it imperative that the history of loading be followed in detail in calculating the final state of stress and strain in a body that has been deformed plastically. Because of mathematical complexity, few problems have been solved completely; but work is in progress in many countries. Probably the most complicated problem solved so far is that of an infinite plate with a circular hole subject to unequal biaxial tension at infinity in such ratio that the entire boundary of the hole is plastic. The solution gives the stresses everywhere, and also the boundary of the plastic region under the assumptions of plane strain and ideal plasticity.¹⁴

CONCLUSION

If practical answers are to be found to many engineering problems of importance and the factor of safety is to be put on a firm calculable basis, a large number of complicated plasticity problems will have to be solved. The great expenditure of effort that will be required makes it desirable to use as simple a theory of plasticity as is permissible for each problem. Much more experimental information is necessary than exists at present. Work has already been started and should continue on an expanded scale along the fruitful path of investigating tubes under internal pressure, tension, and torsion where the ratios are purposely varied during the test to check particular questions. Strong efforts should be made to determine by experimental methods, in several fundamental cases, the importance of the Bauschinger and allied effects, time effects, and the deviation from similarity of the Mohr circles for stress and strain. Little should be taken for granted and all reasonable sounding but unproved statements should be viewed with skepticism. Opinions on what is important and what is not, such as those presented in this paper, may be useful guides but may also be misleading.

ACKNOWLEDGMENT

Acknowledgment is gratefully made to the Office of Naval Research and the Bureau of Ships, United States Department of the Navy, joint sponsors of research in this field at Brown University under contract N7onr-358.

¹⁴ "Plane Elastic-Plastic Problem, Plastic Regions Around Circular Holes in Plates and Beams," by L. A. Galin, *Prikladnaya Matematika i Mekhanika*, Vol. 10, 1946, pp. 365-386.