

41717

MDDC - 454
LADC - 272

01717

U-1717

UNITED STATES ATOMIC ENERGY COMMISSION

ALPHA COUNTERS as USED in RADIOASSAY of PLUTONIUM

by

S. R. Chadwick

Los Alamos Scientific Laboratory

CLASSIFICATION STATEMENT A
Approved for public release
Distribution Unlimited

LIBRARY OF CONGRESS
SCIENCE & TECHNOLOGY PROJECT
TECHNICAL INFORMATION SECTION

12

DEC 7 1948

Date Declassified: November 26, 1946

19961230 128

The issuance of this document does not constitute authority for declassification of classified copies of the same or similar content and title and by the same author.

FILE COPY
Science and Technology Project
Library of Congress
UNCLASSIFIED

Copy #12

Technical Information Division, Oak Ridge Operations
AEC, Oak Ridge, Tenn., 11-15-48--850-12993

Printed in U.S.A.
PRICE 15 CENTS

DTIC QUALITY INSPECTED 4

DISCLAIMER NOTICE

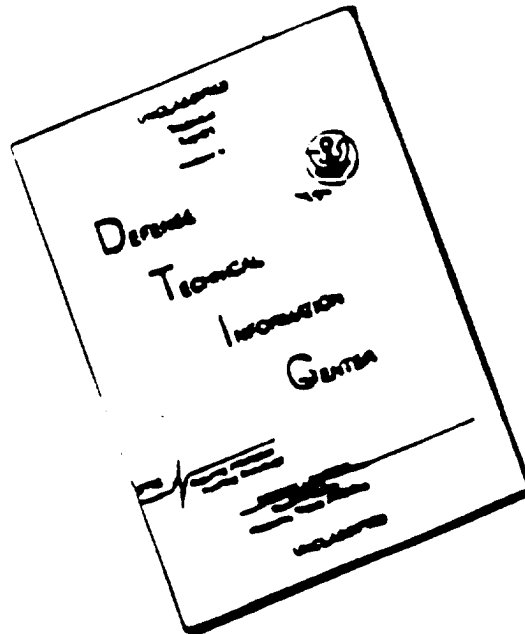

THIS DOCUMENT IS BEST
QUALITY AVAILABLE. THE COPY
FURNISHED TO DTIC CONTAINED
A SIGNIFICANT NUMBER OF
PAGES WHICH DO NOT
REPRODUCE LEGIBLY.

TABLE OF CONTENTS

	Page
1. The Air Counter.....	1
a. Operation of Circuit.....	1
b. The Plateau.....	8
c. Standard Deviation.....	9
d. Coincidence.....	9
e. De-multiplier.....	10
f. Maintenance.....	10
2. The Nitrogen Counter.....	12
a. Operation of Circuit.....	12
b. Maintenance.....	14
c. Operation of Counter.....	14

ABSTRACT

A description of the amplifiers, scalars, and power supplies used with the air and nitrogen chambers is given. Circuit diagrams and shop drawings of the chambers are included in the appendix.

ALPHA COUNTERS AS USED IN RADIOASSAY OF PLUTONIUM

By S. R. Chadwick

I. Principles and Maintenance of the Alpha Counter with Air Ionization Chamber, as manufactured by the Cyclotron Specialties Co., and designated Type B

a. Operation of Circuit:

This alpha counter is of the type known as a parallel-plate counter, with an air ionization chamber. A general outline of operation follows:-

The counter itself comprises three units: (1) the ionization chamber and pre-amplifier, (2) the linear amplifier, and (3) the scaler and power supply unit; this latter unit is composed of a high-voltage power supply, a low-voltage power supply, a scaling circuit, and a thyratron circuit to actuate the mechanical register. An oscilloscope is included in each installation solely for monitoring purposes.

The ionization chamber and pre-amplifier unit are mounted in a wooden box and packed carefully in several thicknesses of felt; the whole assembly is then shock-mounted by suspending it from four bolts which are mounted in sponge rubber, and anchored to a solid surface which must be as free from vibration as possible. The ionization chamber and pre-amplifier case is constructed of brass as shown in the attached drawings. As is apparent from these drawings, the ionization chamber is cylindrical in shape, and is so designed that a cap, on which is mounted a pedestal, is removable from the lower portion of the chamber. That part of the chamber to which this cap locks is insulated from the remainder of the chamber by a polystyrene or lucite ring insulator. Recessed into the opposite end of the chamber is a circular plate, the collection plate, which is well insulated from all other parts of the chamber; the design of the chamber is such that this collection plate is co-axial with, and parallel to, the pedestal when the chamber is closed and ready for use. The distance between the pedestal and collection plate should be approximately one centimeter.

In operation, the sample to be counted is placed on the pedestal and the cap is locked into place in the chamber. A strong electrostatic field then exists between the pedestal and the collection plate; this field is established by connecting the lower portion of the ionization chamber to the high-voltage power supply in the scaler unit of the counter, and the normal operating voltage at this point is 1500 volts positive; this voltage is monitored by a meter installed on the front panel of the scaler unit. As an alpha particle is emitted from the sample in the chamber, it causes ionization of the air along the path which it travels. The positive ions formed are attracted to the collection plate, which is at ground potential, and a positive pulse is formed on the collection plate. Because of the chamber design, which is fixed by the necessity of an undistorted electrostatic field, alpha particles emitted can travel varying distances before striking some portion of the chamber; therefore, the extent of ionization, and, hence, the amplitude of the pulse formed, by each alpha particle is variable within limits. The pulses formed on the collection plate are transmitted to the grid of the pre-amplifier tube to start the process of amplification which is necessary to bring these very weak pulses up to a useful level.

The tube used for pre-amplification is an RCA type 38, and the associated circuit is a simple resistance-coupled amplifier circuit. The screen supply for this stage must be well filtered, and a large by-pass condenser must be used at the screen itself; the source of screen potential is a twenty-two-and-one-half-volt battery, and the voltage at the tube should be eight to ten volts. The plate supply for this tube is a forty-five-volt battery, and the normal operating voltage at the plate of the tube should be approximately fifteen volts. The filament of this tube must be heated by a six-volt battery source, and the cathode is operated at ground potential. This stage is very critical as to the particular tube used, and usually several tubes must be tried before a satisfactory one is obtained; the common fault will be a tendency toward excessive microphonic qualities inherent in the tube. A three-or four-hundred-hour period of aging at subnormal filament voltage of the tube to be used will improve its performance after installation. In operation, filament voltage on this tube will have to be kept very close to the specified value or this stage will become very microphonic.

The output of the pre-amplifier stage is fed to the linear amplifier for further amplification. The linear amplifier is a three-stage resistance-coupled amplifier, using type 6J7 tubes in the first two stages, and a type 6SJ7 in the final stage. The grid circuit of the first stage comprises the shortest time constant of the amplifier (a .0005-mfd coupling condenser, and a 250-thousand-ohm grid resistor) for the purpose of peaking the output pulses of the preamplifier prior to further amplification. The tube used in this first stage must be selected to avoid microphonics. The filament of this tube is operated from a six-volt DC source; the plate and screen from the low-voltage power supply in the scaler unit of the counter.

The output of the first stage is resistance-coupled to a dual gain control network in the grid circuit of the second stage. This gain control network is used in determining the plateau of the counter; this operation will be described in detail later in this report. The second stage is conventional with one exception: the grid is biased to a potential of approximately minus 10 volts by means of a cathode resistor. This bias is made necessary by the fact that the input pulse to the second stage has a positive value, the sequence being positive pulse to the grid of the pre-amplifier, negative pulse input to the first stage of the linear amplifier, positive pulse to the second stage, and a negative pulse input to the final stage. Thus, the first and last stages of the linear amplifier are operated without grid bias, and the second stage is operated with a rather high negative bias.

The output of the second stage is resistance-coupled to the final stage which is conventional in every respect. A feature of the amplifier which is slightly unusual is the necessarily large capacities of all by-pass condensers. This is imperative as the plate and screen supplies of all stages must be well filtered to avoid picking up transients in the amplifier.

The output of the linear amplifier is monitored by an oscilloscope, and is fed through the "count" switch to an input trigger circuit in the scaler unit.¹⁾ This circuit utilizes a type 6SJ7, and a type 6B8 tube, and is an unbalanced variation of a multi-vibrator circuit. The 1) The count switch is so connected that in the "off" position the output of the amplifier is grounded; in the "on" position the output is fed to the grid of the 6SJ7 in the trigger or discriminator circuit.

purpose of this trigger circuit is to furnish a sharp pulse, of constant amplitude, to the first scaling pair, regardless of the characteristics of the pulse by which the circuit is activated. Normally, the 6SJ7 is in a nonconducting state, the 6B8 is conducting, and the grid of the 6SJ7 is biased to a potential of minus 45 volts. As a positive pulse brings the grid of the 6SJ7 up to a conducting level, the plate voltage at the 6SJ7 falls from approximately 375 to 140 volts; this raises the grid bias on the 6B8 from minus 10 to minus 60 volts, and causes this tube to become nonconducting. When the 6B8 becomes nonconducting, its rise in plate voltage causes the suppressor grid bias on the 6SJ7 to fall from minus 60 to 0 volts. Because of this change in suppressor grid bias, the trigger circuit cannot return to its stable state until the input pulse has decayed to a considerably lower value than that which was originally required to unbalance the circuit; thus, when the circuit is tripped by a pulse of a given peak potential, the voltage at the plate of the 6B8 remains constant until the input pulse has decayed sufficiently to allow the circuit to return to its stable state, an almost instantaneous reaction. The pulse then formed at the plate of the 6B8 closely approximates a square wave, and this pulse is applied to the diode plates of the 6B8. Since this pulse has a positive value in respect to the cathode of the 6B8, rectification of this pulse takes place, and a sharp negative pulse is developed across the diode load resistor. This negative pulse is fed to the first scaling pair of the scaling circuit.

Each of the three scaling pairs in the scaling circuit comprises two type-6C5 tubes, and the purpose of each scaling pair, in conjunction with an inverter stage, is to pass only one pulse for each two pulses received. The scaling pair is an adaptation of a multi-vibrator circuit which has two stable positions; that is, it is stable with either of the two tubes in a conducting state. The plate of each scaling tube is coupled back to the grid of its opposing tube through a 400K-ohm resistor. The grid of each tube is returned to ground through a 100K-ohm resistor in series with a source of negative potential of a value of 70 volts. The cathode of each tube is essentially at ground potential. If the grid-to-cathode potential of either tube at any time be now considered, it is seen to be the resultant of two voltages of opposite polarity. One of these voltages is the drop across the 100K-ohm grid resistor due to the current flow caused by the positive voltage at the plate of the opposing tube, since this voltage is always of a greater positive value than the negative potential of 70 volts which opposes current flow. This voltage, thus, will always be of a polarity which would tend to keep the grid positive in respect to ground, and its value will be one fifth of the net difference between the voltage at the plate of the opposing tube, and 70 volts. The second voltage is, of course, the 70-volt negative source, and its polarity is such as to tend to keep the grid negative in respect to ground.

In either stable state of the circuit, one tube is conducting, and the other nonconducting. The voltage at the plate of the nonconducting tube is the full value of the source, or approximately 400 volts. The grid potential, in respect to ground, of the conducting tube is, therefore, the difference between one fifth of 400 minus 70, and 70 volts, or minus 4 volts; this value, of course, tends to keep the tube conducting.

The voltage at the plate of the conducting tube is of a positive value of only 100 volts, however, because of the drop across the plate load resistor. The grid potential, in

respect to ground, of the nonconducting tube is, therefore, the difference between one fifth of 100 minus 70, and 70 volts, or approximately minus 63 volts; this keeps the tube nonconducting.

When a negative pulse is applied to the grids of both scaling tubes simultaneously, the nonconducting tube is not affected, since its grid is merely carried to a more negative potential than the value which is already maintaining the tube in a nonconducting state. The negative pulse upon striking the grid of the conducting tube, however, carries the grid of this tube to a value beyond cutoff, and causes the tube to become nonconducting; as this tube becomes nonconducting, its plate voltage rises, and causes the grid-to-cathode potential of the originally nonconducting tube to fall from cutoff value to within conducting range of the tube. Thus, the originally nonconducting tube becomes conducting, and its drop in plate voltage causes a corresponding increase in negative bias on the tube which was originally conducting, thus retaining it in the nonconducting state induced when the negative pulse was first applied to its grid.

If the action of the scaling pair now be considered as it is actuated by a series of negative pulses, it is apparent that on the first pulse received, one tube will change from a nonconducting to a conducting state, and at the same time, the opposing tube will change from the conducting to a nonconducting state; on receipt of the second pulse, this action will be reversed, and on receipt of the third pulse, the action will again be the same as that induced when the first pulse was applied to the scaling pair. Thus, at the plate of either tube, starting with the tube in a conducting state, the voltage will rise sharply upon receipt of the first pulse, and will remain at that level until the second pulse is applied, at which time it will fall sharply; this sequence results in the formation of a rectangular wave at the plate of either tube; two successive negative pulses are, of course, required to form one full rectangular wave at either plate.

The plate load resistor of only one scaling tube is tapped; this point is returned to ground through a series RC circuit, and a negative voltage source of a value of 40 volts. As the scaling tube passes from a conducting to a nonconducting state, the voltage applied to the condenser of the RC circuit rises sharply; current then flows through the resistor of the RC circuit to charge the condenser to the new level, and a positive pulse, superimposed on a reference level of minus 40 volts, is developed across the resistor. As the scaling tube's plate voltage falls, a negative pulse, superimposed on the reference level of minus 40 volts, is developed across the resistor. The characteristics of the pulses formed are determined by the time constant of the RC circuit, and since this time constant is quite short, the pulses formed are sharp. The pulses developed across the resistor of the RC circuit are applied to the grid of the inverter stage. The inverter stage utilizes a type-6C5 tube, and, since this tube is biased to a value of minus 40 volts, the inverter stage is actuated only by the positive pulses applied to the grid of the tube; the output of this tube is, of course, a negative pulse.

To summarize the overall effect of the scaling pair and the associated inverter stage; two successive negative pulses applied to the grids of the scaling pair result in a rectangular wave at the plate of each scaling tube, one rectangular wave is transformed

into one negative, and one positive pulse; the inverter stage is actuated only by the positive pulse, and a negative pulse is formed at the plate of the inverter tube; thus, two successive negative pulses, when applied to the scaling pair, result in an output of one negative pulse from the inverter stage.

The output of the first inverter stage is applied to the second scaling pair and its associated inverter stage; these are identical to the first set. The output of the second inverter stage is fed to a third scaling pair; its operation is the same as that of the first two scaling pairs, but its output is utilized in a slightly different manner since it is the final scaling pair.

As the overall scaling circuit is composed of three scaling pairs, and each pair divides the number of pulses it receives by a factor of two, it is apparent that only one pulse will be transmitted from the third scaling pair for every eight pulses which are applied to the scaling circuit. To take account of any fraction of eight pulses applied during a given length of time, an interpolation circuit is included in the scaling circuit. The cathode of only one of the tubes in each scaling pair is grounded directly; in the first and second scaling pairs, it is the cathode of the tube whose output is not utilized; in the third pair, it is the cathode of the tube whose output is utilized. The cathodes of the other tubes of each pair are each returned to the center tap of a potentiometer. Each potentiometer is so connected as to comprise a shunt for the "Interpolate" meter; this is a 0-to-50 milliamperere meter which is calibrated to read evenly a scale of one-to-eight; it is mounted on the front panel. The negative side of the interpolate meter is grounded through a switch which is mounted on the front panel and is labeled "Reset"; this is a single-pole, single-throw toggle switch, and is so connected that in its "on" position, the ground circuit for the interpolate meter is opened, and in the "off" position the ground circuit is closed. In operation, of course, a portion of the cathode current of each of the three scaling tubes which are connected into the interpolation circuit must pass through the interpolate meter. The potentiometers are so adjusted that enough cathode current of the first scaling pair tube flows through the meter to cause it to read to the "one" mark; sufficient cathode current of the second scaling pair tube to cause the meter to read to the "two" mark; and enough cathode current of the third scaling pair tube to cause the meter to read to the "four" mark.

Overall operation of the scaling circuit is as follows; before any pulses are applied to the scaling circuit, the circuit must be cleared by bringing the "reset" switch to its "on" position, and back to its "off" position. This momentarily opens the cathode circuits of the three scaling tubes involved in interpolation, and brings these tubes to a nonconducting state; the interpolate meter now, of course, will read zero. If pulses are now applied to the trigger or discriminator circuit by throwing the "count" switch to its "on" position, and thence to be first scaling pair, the first pulse will change the interpolation tube of the first scaling pair from a nonconducting to a conducting state; the interpolate meter will now read "one". The second pulse changes the interpolation tube from conducting to nonconducting, and since it is the output of this tube which drives the second scaling pair, the interpolation tube of the second scaling pair is now changed from nonconducting to conducting, and the interpolate meter reads "two". The third pulse changes the interpolation tube of the first pair back to a conducting state; this does not energize the second scaling pair, but the interpolate meter

now reads the sum of the currents of the interpolation tubes in both the first and second scaling pairs; thus, the meter reads to the "three" mark. The fourth pulse again changes the interpolation tube in first scaling pair from a conducting to a nonconducting state; this causes the interpolation tube in the second pair to change from a conducting to a nonconducting state; and, since the interpolation tube of the second scaling pair drives the third scaling pair, the interpolation tube of the third scaling pair is now changed from a nonconducting to a conducting state, and the interpolate meter reads "four". The fifth pulse applied to the circuit again causes the interpolation tube of the first scaling pair to become conducting, and the interpolate meter to read "five"; the sixth pulse changes the interpolation tube of the first pair to nonconducting, and, thus, the interpolation tube of the second pair to conducting, and the interpolate meter reads "six". The seventh pulse causes the interpolation tube of the first pair to become conducting once more, and the meter to read "seven". It is apparent that at this point the interpolation tube of each scaling pair is conducting current; therefore, on receipt of the eighth pulse, the interpolation tube of the first pair is changed to a nonconducting state. This changes the interpolation tube of the second pair to a nonconducting state, and this in turn changes the interpolation tube of the third pair to a nonconducting state; the circuit is now returned to its original condition in which all three interpolation tubes are in a nonconducting state.

As previously specified, it is not the output of the interpolation tube in the third scaling pair which is utilized, but that of the opposing tube; the reason for this is apparent when it is considered that the output of the final scaling pair, after passing through an inverter stage, is used to drive a thyatron. The thyatron is biased negatively to a value of approximately 100 volts, and, thus, a positive pulse is required to fire it. To obtain a positive pulse at the grid of the thyatron, a negative pulse must be applied to the grid of the inverter tube; to obtain a negative pulse at the grid of the inverter tube, the pulse must be that formed when a scaling tube passes from a nonconducting state to a conducting state. Since the interpolate tube of the third scaling pair changes from a conducting to a nonconducting state upon receipt of the eighth pulse by the scaling circuit, it is the output of the opposite tube of this pair which must be utilized; this tube's action is, of course, the reverse of that of the interpolate tube upon receipt of the eighth pulse by the scaling circuit.

The output of the thyatron is used to actuate a mechanical register which is connected into its plate circuit by means of a receptacle set in the front panel, and designated "register".

In the scaler unit, there are two low voltage power supplies; one is a positive supply which furnishes approximately 370 to 400 volts DC for the plate and screen supplies of the scaling circuit and linear amplifier; the other is a negative power supply and furnishes the bias voltages for the scaling and thyatron circuits. Both power supplies are conventional, and are critical only in respect to the ripple content of the output voltage.

The high-voltage power supply contained in the scaler unit furnishes the collection voltage to the ionization chamber. This is a regulated power supply designed to furnish a maximum of 2500 volts positive at very low current drain. A variac on the front panel controls the value of AC voltage applied to the high-voltage transformer of this supply; the variac

control is designated "stabilize". The high-voltage winding of this power transformer should have a much higher voltage rating than that necessary to furnish the required output DC voltage in order to insure that no leakage will occur within the transformer under normal operating conditions. As will be noted, all components of the power supply are rated to withstand much more than operating voltage for the same reason -- to prevent leakage at any point within the circuit; this is a very important point to consider throughout the entire power supply circuit, as a major proportion of interference picked up by the preamplifier stage is a direct result of leakage within the power supply. The rectifier tube of the power supply is a type 2X2/879; the filter comprises a .05.3000-volt paper condenser, and a Thordarson type T-17C40 television choke. The choke is placed in the low-voltage side of the circuit, and has a very high inductance rating, but will handle only small amounts of current (maximum current rating three milliamperes). Across the power supply, on the output side of the filter, are two parallel resistive branches, which, in conjunction with a tube type 47, form the regulating portion of the high-voltage circuit. The voltage drop across a portion of one of the resistive branches is used to ignite a neon lamp, and a portion of the stabilized voltage across this neon lamp is used to maintain the grid of the 47 at a positive potential in respect to the most negative point of the high-voltage circuit; this voltage on the grid of the 47 is adjustable by means of a potentiometer which is set into the chassis of the counter. The second resistive branch is composed of a 50K-ohm wire-wound rheostat, a 50K-ohm fixed resistor, and four other resistors which total 1.7 megohms; the drop across the rheostat is used to maintain the cathode of the 47 at a given positive potential in respect to the most negative point of the high-voltage circuit; the drop across the fixed 50K-ohm resistor furnishes screen voltage for the 47; and the remaining 1.7 megohms resistance serves to complete the circuit across the high-voltage supply. The control knob for the 50K-ohm rheostat is mounted on the front panel of the counter, and is designated "voltage". The plate load of the 47 is composed of the kilovolt meter (mounted on the front panel) and resistance totaling 2.5 megohms, and in parallel with these is a .5-mfd 3000-volt oil-filled condenser for filtering purposes. When properly adjusted the circuit's regulating ability depends upon a constant current flow being maintained through the regulating tube, regardless of fluctuations in the voltage supply. Since the cathode is free to change voltage in accordance with changes in output voltage of the rectifier, while the grid is maintained at a stable potential, it is apparent that with an increase in voltage across the circuit the grid voltage in respect to the cathode becomes more negative and tends to prevent an increase in current flow through the tube, while with a decrease in voltage across the circuit the tube will act to prevent a decrease in current flow. The output voltage of the high-voltage circuit is taken off across the load resistor of the regulating tube; however, the low-potential end of this load resistor is not grounded directly; instead it is returned to the center tap of a potentiometer which is shunted across a VR-150 tube. This tube is supplied from the low-voltage, negative, power supply. The purpose of this circuit arrangement is to provide a means by which the high-voltage output may be lowered by any amount up to 150 volts without disturbing the regulation of the circuit. The control for the potentiometer which governs the amount by which the high voltage may be lowered is mounted on the front panel and is marked "subtract". However, this feature is incorporated only for use when the scaler is fed from the output of a Geiger tube and in this application need not be considered.

The procedure for setting the circuit for proper regulation is as follows: the

potentiometer which regulates the grid voltage on the 47 should be set approximately at its mid position, the "voltage" control to its extreme clockwise position, and the "stabilize" control to the point necessary to give operating output voltage as read by the panel meter. The "test" switch is then thrown to its "on" position; this inserts a 50-ohm resistor into the feeder line to the primary of the high-voltage transformer, and, thus, drops the output voltage of the circuit. The "stabilize" control is now turned clockwise to bring the output voltage back up to the point at which it is desired to operate; if, when the "test" switch is returned to its "off" position, the output voltage rises, the "voltage" control is rotated counter-clockwise to decrease it to the desired level. This procedure is repeated until the point is reached at which the output voltage does not change when the "test" switch is changed to either its "on" or "off" positions. If this point is not reached within the range of the "voltage" control, the grid voltage on the 47 will have to be raised slightly, and the adjustment procedure followed at this new level.

b. The Plateau

As mentioned previously, the pulses formed in the ionization chamber, as alpha particles are emitted from the sample to be counted, vary considerably in amplitude. Also, a certain amount of extraneous interference is picked up by the pre-amplifier; part of this interference is straight pickup, and some is due to amplification of tube disturbances within the pre-amplifier tube. However, it is apparent that the output of the amplifier must be set in some manner so that all the pulses formed will be of sufficient amplitude to trip the discriminator of the scaler unit, while the background disturbances are not amplified sufficiently to trip the discriminator. This is accomplished by means of the gain controls on the Linear Amplifier. The "coarse" gain control regulates the gain of the amplifier in steps; the "fine" gain control acts as a vernier control for each step. To determine the gain control setting at which the amplifier should operate, a standard sample is placed in the counter, and the gain controls set at a point at which the standard counts considerably lower than its rated value. Counts are then made approximately 20 points apart on the fine control, until a point is reached at which the standard counts its normal value; at this point several counts should be taken to determine definitely that all pulses are being recorded, beyond this point three or four more counts at higher gain settings should be made. The standard sample is then removed, the gain controls set at the point at which the standard first counted to rated value, and the counts per minute recorded with no sample in the chamber; this value should be quite low - in any event, less than five counts per minute. From this point, the gain is advanced at the same rate as previously, and the counts per minute, or "background", recorded at each setting. When the background becomes greater than five counts per minute, it is apparent that the point has been reached at which the external disturbances normally picked up by the amplifier are being recorded; operation above this point is, of course, impossible. Thus, the lowest, and the highest gain settings at which the amplifier can be operated have been determined, and the gain is set for permanent operation halfway between these points. The distance between the highest and lowest possible operation points should approach three full steps of the "coarse" gain control for satisfactory operation.

c. Standard Deviation:

The error placed on counting data was the standard deviation, obtained by taking the square root of the total counts recorded and dividing by the time interval. This gave a number corresponding to the counting error in counts per minute. The physical significance of this error is that there is a two-to-one chance that the true counting rate is within the limits of error set by the standard deviation. The error contributed by the background was usually ignored because it was so small.

d. Coincidence:

As the emission of alpha particles from the sample to be counted is a random occurrence, it happens that two particles, at times, are emitted so closely together that the amplifier cannot distinguish between them, and the two particles will then be counted only as one. The number of times that this will happen during any given interval is a function of the number of particles emitted during this interval. For accurate counting this phenomena must be taken into account, and, therefore, for each chamber there is a chart on which the number of counts to be added to the recorded count is plotted versus the number of counts per minute of the sample counted. This curve takes roughly the shape of an exponential curve, and the counter is not used for samples which will cause a coincidence correction greater than five per cent. The coincidence curve for any chamber is determined experimentally in the following manner; - a standard sample of a low value (approximately 400 c/m) is counted for the period necessary to obtain a standard deviation in the region of .2 per cent; a second standard sample of approximately the same value is counted in the same manner; the two samples are then counted together, and the difference between the combined count and the sum of the two separate counts represents the coincidence correction at this point. Since deviation must be taken into account, the difference between the two counts is subject to some deviation, however. Thus, if for example, one sample be counted to a deviation of .2% separately, and the second sample to .2% separately, the total deviation for the sum of the two is the square root of the sum of the squares of the two deviations; the total deviation to which the coincidence correction is subject, is then the square root of the sum of the squares of the deviations of the counts of the two samples counted separately and the deviation of the count obtained when the two samples are counted in combination.

After this point has been determined two samples, which count approximately 800 c/m each, are counted separately, and in combination, in the same manner to determine the coincidence at the next point which is about 1600 c/m. The only change in procedure is that the coincidence correction as determined at 800 c/m must be added to the separate counts to obtain the true count of each sample. Various other points on the curve may now be determined in the same manner by various combinations of the standards already calibrated, and by combinations of other higher count standards which can be calibrated in the manner already described.

When minor circuit changes must be made for maintenance purposes, it is usually sufficient to check the coincidence curve at a few points by merely counting standards which

are already carefully calibrated.

e. De-multiplier

For counting samples which are too high for the normal range of the counter, the chamber may be fitted with a de-multiplier cap. With this type of cap the sample is completely enclosed except for a small orifice centered just below the collection plate. Thus, only a portion of the alpha particles emitted by the sample pass through into the ionization chamber and are counted. The proportion of particles counted may be determined by experiment; this factor is determined by the ratio of the area of the orifice to the area of the top plate of the cap.

f. Maintenance:

A large proportion of the trouble encountered in operation of these counters is due to interference which may be picked up at any point in the pre-amplifier or amplifier, although, in general, the final stage of the amplifier is not very susceptible to pickup as the signal at this point is of sufficient amplitude as to be little affected by minor disturbances. When interference is encountered, the first test that should be made is to compare the background of the counter with the collection voltage supply both on and off, as leakage or sparking at any point within the collection voltage circuit is a common cause of interference. If the interference is traced to the collection voltage supply, it should not be assumed that the defect will be obvious, as a much less serious defect than that which will cause a visible or audible spark will cause sufficient interference to render the counter unusable. A resistance test of circuit components is of limited value; in general, if the resistance across the component, or from the high side of the component to ground, measures at least 100 megohms, the part can be assumed to be fit for use. A point that should be checked carefully is the ionization chamber itself, as a small hair or piece of lint caught on the pedestal will provide a path across the chamber for a high-voltage discharge. The filter condenser across the chamber itself is a frequent cause of interference, as is the filter condenser across the output of the power supply. In some cases the only positive method for determining the exact cause of the interference is a systematic replacement of parts.

If the source of interference is found not to be the collection voltage supply, the voltage supplies for all amplifier tube elements should be checked carefully with a sensitive oscilloscope; probably the most common fault encountered in this event will be the discovery of transients on the 6-volt DC filament supply. The filament of the 38 used for pre-amplification is particularly susceptible to this trouble. Faulty electrolytic by-pass condensers on the screen and plate supplies will often be found to be the cause, also.

A second cause of high background is, of course, contamination of the chamber. If any active material becomes lodged within the chamber, the particles emitted from it will cause counts. Usually particles of active material may be removed by carefully cleaning the chamber with tissue moistened with hexane or carbon tetrachloride; if this treatment does not suffice it will be necessary to remove a few thousandths of an inch of all exposed surfaces with garnet cloth.

Occasionally 60-cycle AC pickup will appear in the output of the amplifier; this is again usually traceable to the collection voltage supply, and will be found to be the result of excessive current drain on the power supply. When the current drawn through the filter choke becomes appreciable, saturation of the choke seems to take place and the filtering action becomes impaired. The second major cause of 60-cycle pickup is the existence of more than one ground connection between the counter itself and the pre-amplifier; it is advisable to ground all cable shields at the counter end only to avoid this trouble.

There is a strong tendency for the counter to develop excessive microphonic qualities. The major causes are: an amplifier tube becoming microphonic, the pedestal in the chamber becoming loose, the sample plate failing to contact the pedestal solidly so that it is subject to vibrations, the pedestal being so adjusted as to be too close to the collection plate, and a drop in the filament, or plate and screen supply, voltage sources.

Failure of the scaling circuit is a recurrent fault. Completely erratic scaling with no pattern will indicate a faulty filter condenser, usually in the positive low-voltage power supply, but it may be in the negative low-voltage power supply. If it is found that this is not the cause, the rectifier tube in the positive low-voltage power supply should be checked for poor emission. If a single scaling pair becomes faulty, the scaling circuit will follow a faulty scaling pattern: for example, it may register correctly up to a given level and fail to follow through its regular pattern after that point, returning to zero each time. The faulty scaling pair is easily determined by observing the action of the scaling circuit as it is energized by the output from a low count standard, - one in the region of 50 to 100 c/m. Both tubes of the scaling pair should then be checked for poor emission, and for balanced emission. If the tubes check favorably, the scaling pair will have to be rebalanced by changing the value of one plate-to-grid coupling resistor; the best check for balance is, of course, to compare the grid voltages of the tubes in both conducting and nonconducting states; these voltages should be approximately the same for proper operation.

II. The Nitrogen Counter

a. Operation of Circuit:

The nitrogen counter comprises three units: the ionization chamber and amplifier, the scaler, and the dual power supply. Much of the data previously outlined in regard to the air chamber apply equally to this type counter; specifically, the data as regards plateau, standard deviation, coincidence correction and method of determining coincidence, apply exactly.

The chamber itself is a parallel-plate chamber, but is filled with nitrogen gas rather than with air because N_2 does not combine with free electrons as O_2 does. The collection plate is at a positive potential in respect to the sample holder in this chamber, and thus, instead of positive ions being collected to form a pulse, electrons are collected as each alpha particle is emitted. Because of the much smaller mass of the electrons as compared with ions, the time interval required for all the electrons to be attracted to the collection plate is much shorter than the collection time in the air chamber, and consequently the pulses formed are a great deal sharper than in the air chamber. Since the collection time of the nitrogen chamber is so much shorter than that of the air chamber, it is apparent that the relative time interval between pulses is much greater in the nitrogen chamber, and, thus, it is possible to count samples of a much higher activity than can be counted with an air chamber. The range for which the nitrogen counter is used is from four thousand to two hundred thousand counts per minute.

The amplifier used with the nitrogen chamber is an eight-stage resistance-coupled high-frequency amplifier. A type 6AK5 is used in the first stage; however, the tube used for this stage must be carefully selected, as only a small percentage of these tubes have a sufficiently low noise level to be satisfactory. Following the 6AK5 stages, are four stages which utilize type-6AC7 tubes; the screen grid voltage on these four stages is raised successively, so that the gain of each stage increases. To increase the overall stability of the amplifier, negative feedback is introduced into the first and third 6AC7 stages, and into the sixth stage, which utilizes a type-6AG7 tube. The amount of feedback which may be introduced into the third 6AC7 stage can be regulated by means of a step switch which is mounted on the front panel of the amplifier, and the overall gain of the amplifier may be regulated by this switch. The seventh stage of the amplifier uses a type-6K6 tube, and the final stage is a cathode follower to prevent any loading of the amplifier by the scaler unit; this final stage uses a type-6V6 tube. The load resistor of the cathode follower stage is a potentiometer, and the output of the amplifier is taken off the center tap of this potentiometer; thus, a second gain control, which is used for fine adjustment, is achieved. Plate and screen voltage for the entire amplifier is furnished by the external power supply; the filaments of all tubes in the amplifier are supplied from an external 6-volt DC source. In general, the principal requirements of the amplifier are great stability, high-frequency response, and very low background noise level, especially in the first three stages.

The discriminator circuit of the scaler unit is quite similar to that of the air chamber; however, two 6AC7 tubes are used for conversion of the input pulse to a rectan-

gular wave, and, to convert this wave to a pulse, and to invert the pulse to drive the first scaling pair, a short-time-constant RC grid circuit feeding a type-6SN7 tube is used. The grid bias on the input 6AC7 of the discriminator pair, is regulated by a potentiometer adjustment; this, of course, is to regulate the trip level of the circuit. It is convenient to locate the control for this potentiometer on the front panel of the scaler; the gain of the amplifier can then be set so that the discriminator will be tripped at approximately one-third full setting of its adjustment; the plateau of the counter can then be run by changing the trip level of the discriminator rather than the gain of the amplifier. By this means it is possible to achieve greater stability of operation since the amplifier is always operated at constant gain setting.

The scaling pairs of this counter are of a plug-in type, and consist of one type-6H6 tube and one type-6SN7. These scaling pairs differ from those of the air counter chiefly in the method of coupling; in the nitrogen counter scaling pairs, the coupling is accomplished by means of the double diode, type-6H6 tube. In this scaling circuit there is no inverter stage between scaling pairs; each scaling pair drives the succeeding pair directly. The cathodes of each 6H6 are tied together, and connected directly to a point on the load resistor of one triode section of the 6SN7 in the preceding scaling pair; each scaling pair is tripped only when this preceding triode section passes from a nonconducting to a conducting state. In considering a single pair, which has been cleared, that is, one that is in a state such that it must be tripped twice in order to trigger its succeeding pair once, it is seen that the driving triode section is in a conducting state while the other triode section is in a nonconducting state. As that plate of the 6H6 which is connected to the plate of the nonconducting triode is at the same potential as its cathode, no current will flow through this diode section; the other plate of the 6H6, since it is connected to the plate of the conducting triode section, is at a negative potential in respect to its cathode. If the cathode potential of the 6H6 now drops, as the preceding driving triode passes from a nonconducting to a conducting state, current will flow in that diode section the plate of which is connected to the plate of the nonconducting triode, and pulse will be developed across the diode load resistor, which is also the load resistor for the interpolate triode section. As the voltage at the plate of the interpolate triode drops, the grid voltage of the driving triode section falls because of the plate-to-grid coupling, and this triode becomes nonconducting; as the driving triode becomes nonconducting, the grid voltage of the interpolate triode rises and causes this triode section to become conducting; the voltage drop across the load resistor of the triode which has now passed to a conducting state ignites a neon lamp which is used as an interpolation indicator. When the cathode potential of the 6H6 rises again as the triode which is driving the pair under consideration returns to a nonconducting state, a positive pulse is applied to the grid of the triode which is already in a conducting state; this, of course, does not affect the scaling pair. When the driving triode again becomes conducting, the effect on the scaling pair is to return it to its original state in the same fashion as just outlined, and as this change is made, the next succeeding scaling pair is, of course, tripped once.

The scaling circuit contains eight scaling pairs; the factor of the total scaling circuit is, therefore, 256; however, a switch is provided on the front panel of the scaler by means of which the last two scaling pairs may be cut out of the circuit, and a scale of 32 used. The final scaling pair drives a type-6V6 tube which is used to actuate a mechanical

register.

The power supply of the counter contains a low-voltage power supply, which furnishes an operating value of 300 volts at approximately 110 milliamperes, and the collection voltage supply which is operated at minus 1200 volts. The low-voltage power supply is regulated by means of four type-6V6 tubes used as passing tubes, and a type 6SL7 as a double voltage amplifier. One triode section of the 6SL7 is controlled by variations in input voltage to the passing tubes, and the other section by variations in output voltage; the drop across the common load resistor of the two triode sections controls the grid bias on the passing tubes. The collection voltage supply is exactly the same as that in the air counter except, of course, that it is inverted to give a negative output.

b. Maintenance:

The most commonly encountered fault will be failure of the scaling pairs; if these scaling pairs become only slightly unbalanced, they will frequently develop a reaction time which is too slow to handle the number of pulses which must be counted; the result of this flaw will be that the counter will count either high or low by a moderately constant percentage. This trouble will, of course, most often be encountered in the first three scaling pairs. Another cause of erratic counting frequently encountered is contamination of the nitrogen gas used in the chamber; a very high degree of purity is demanded of this gas for satisfactory operation. Instability of the amplifier resulting in a shifting plateau is often encountered; this will often be found to be the result of changing tube characteristics, but may also result from variations in voltage output of the power supply. The feed-through insulator which carries the high voltage lead into the ionization chamber is a frequent source of trouble; this insulator is subject to extremes of temperature, and under these conditions must yet withstand high voltages, and moderate pressures.

c. Operation of Counter:

After all power is turned on in the counter, it should be allowed to warm up for at least twenty minutes so that the entire unit will have an opportunity to reach stability. The sample is then placed in the chamber, and the pressure plate affixed; the chamber should then be evacuated and the nuts on the pressure plate tightened with a vacuum in the chamber; nitrogen gas is then fed into the chamber, - usual operating pressure being approximately three pounds; the chamber is then again evacuated and refilled to remove the last vestiges of air; the counter is then ready for operation.

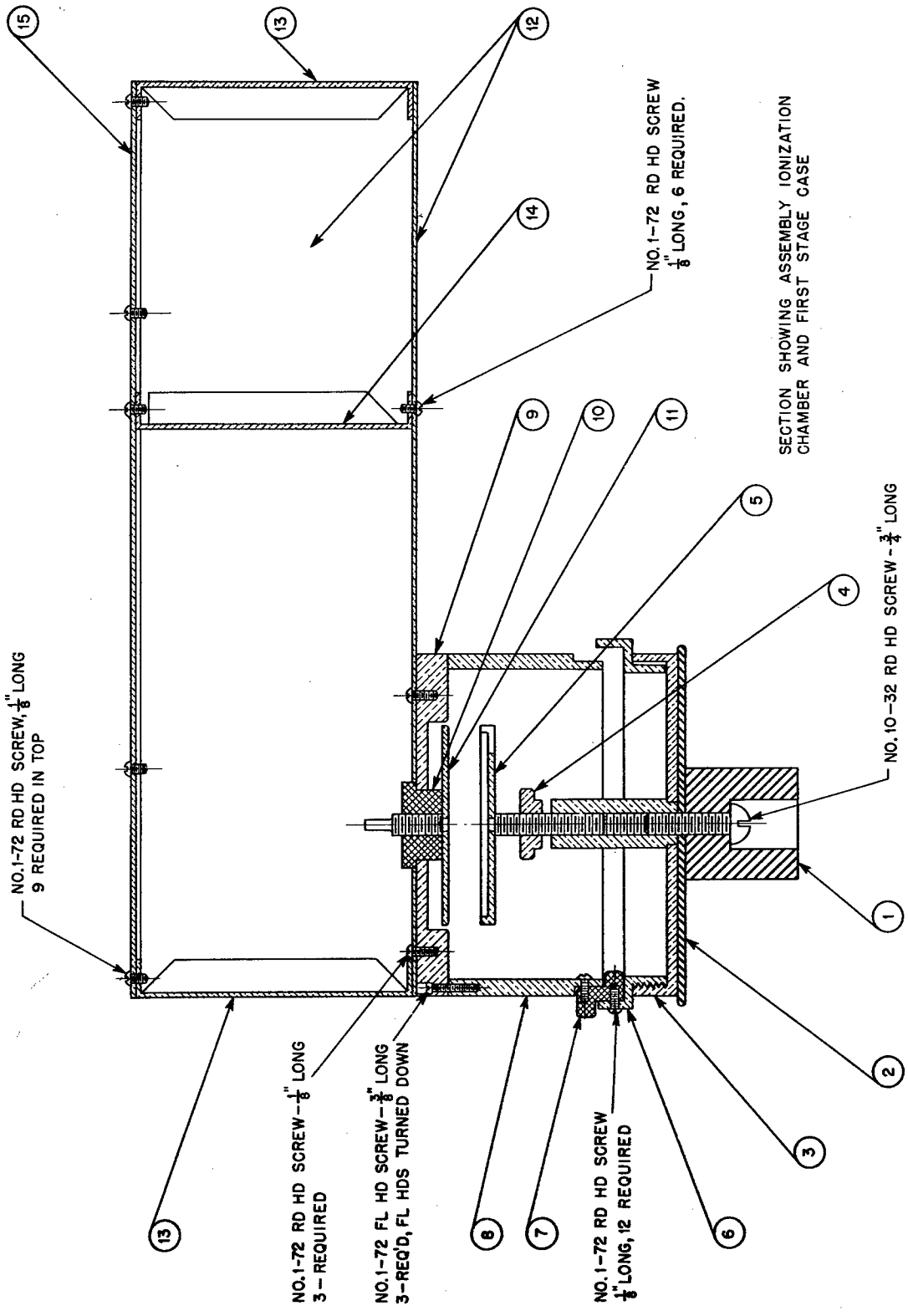

Figure 2. Air counter chamber assembly.

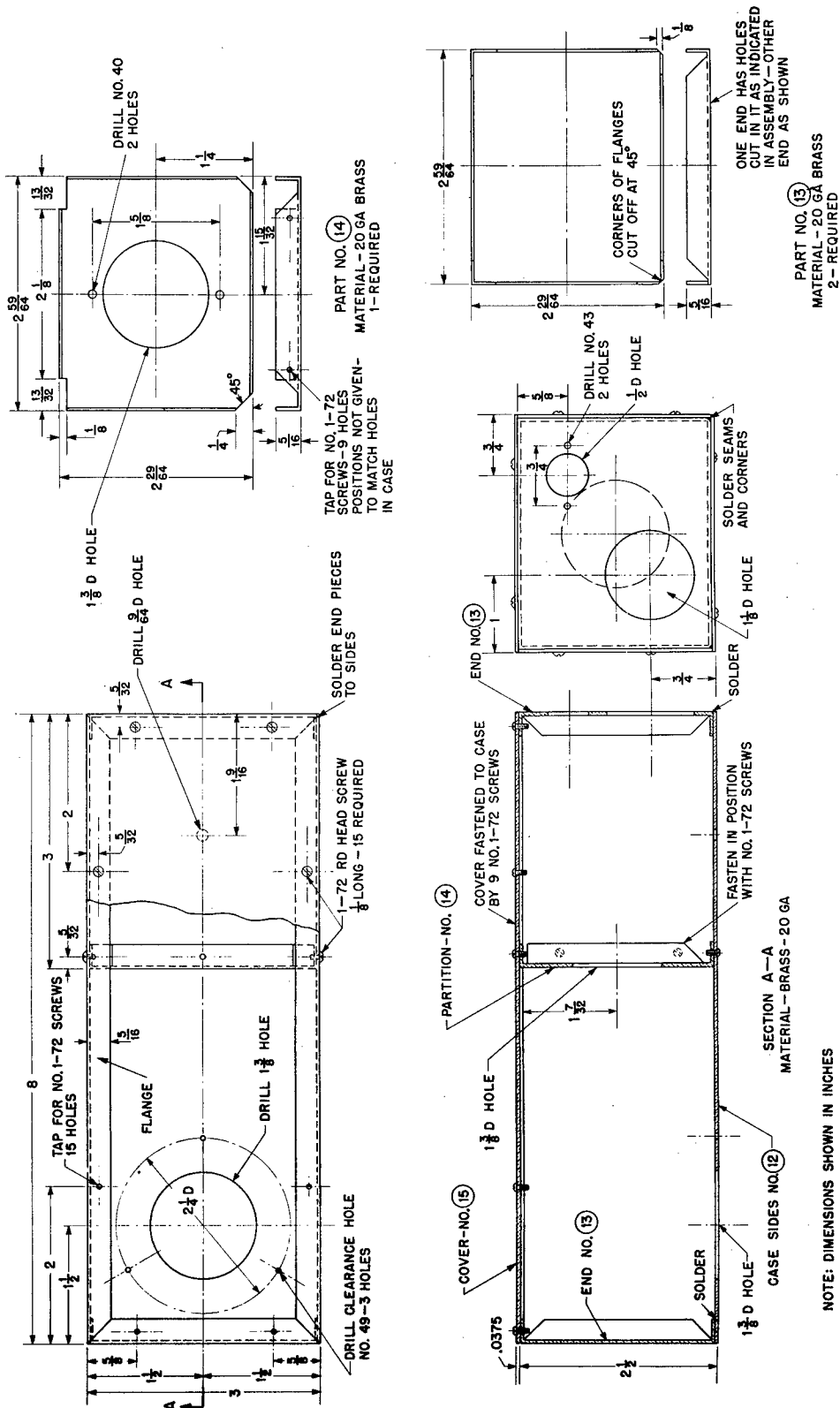

Figure 3. Air counter case assembly and detail.

NOTE: DIMENSIONS SHOWN IN INCHES

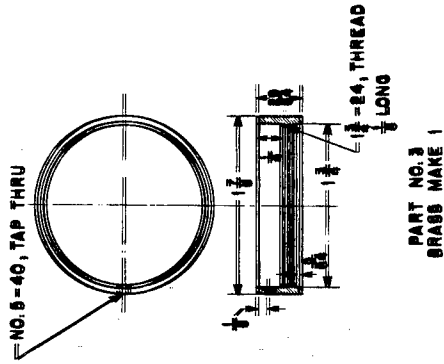
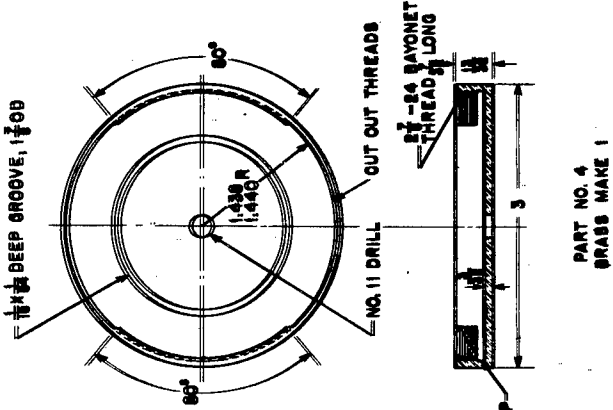
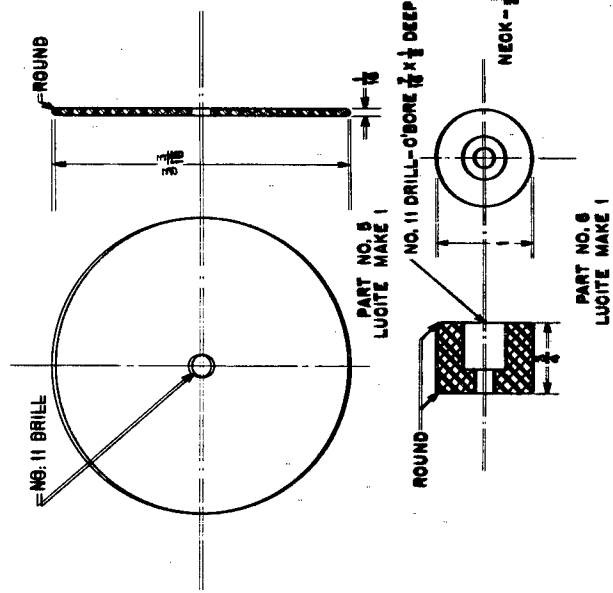
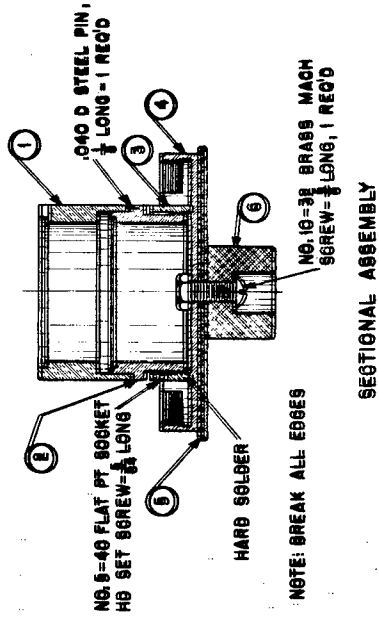
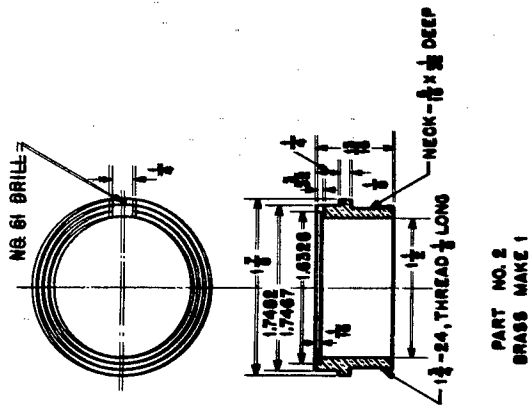
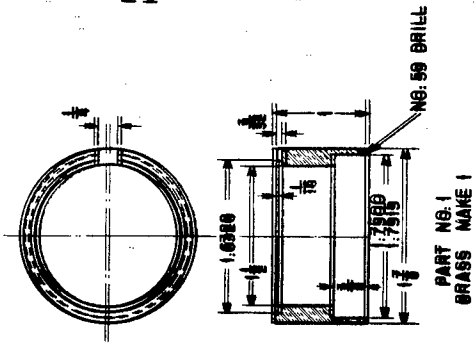

Figure 5. Air de-multiplier cap.

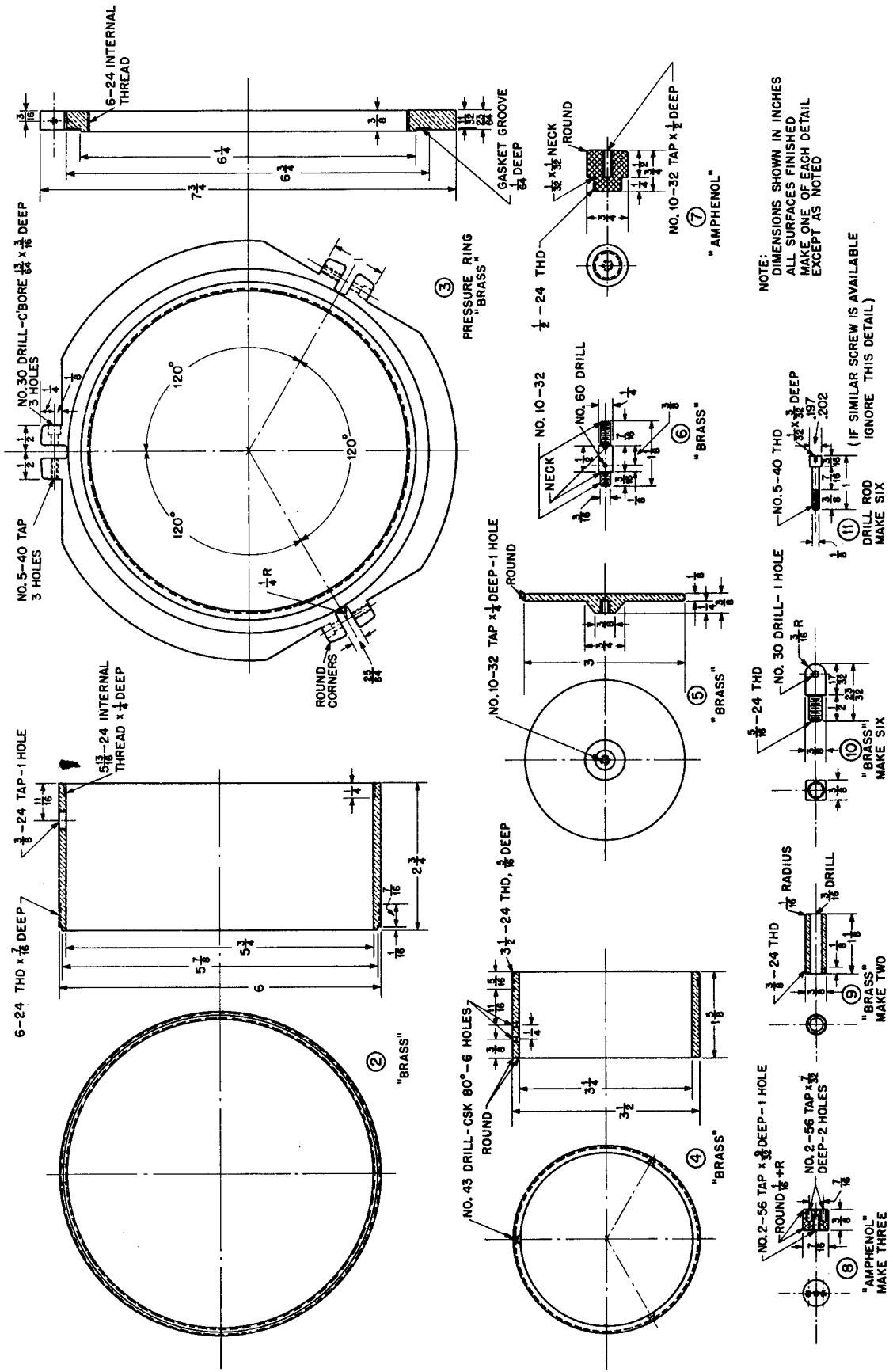
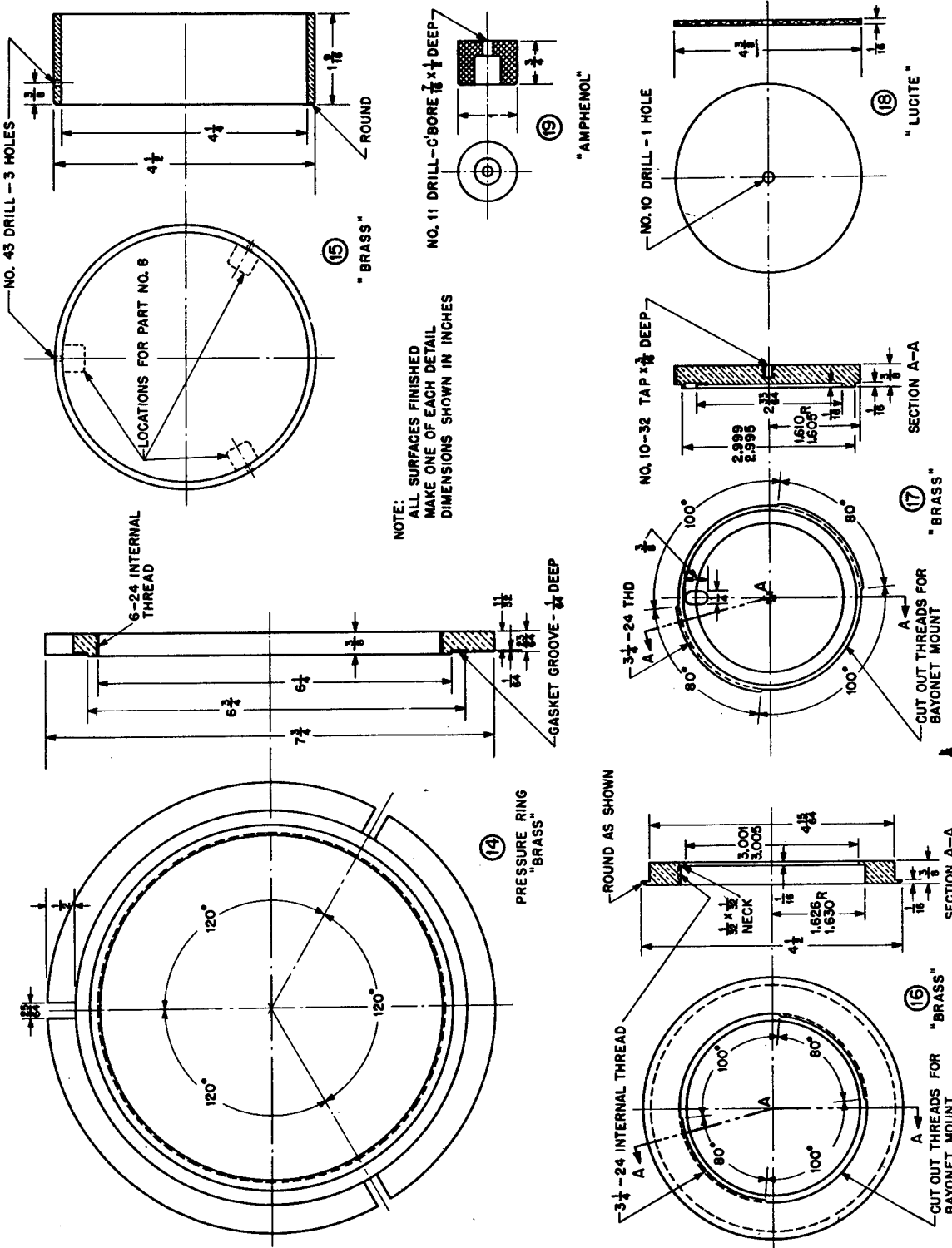

Figure 11. Nitrogen counter chamber detail.



NOTE:
ALL SURFACES FINISHED
MAKE ONE OF EACH DETAIL
DIMENSIONS SHOWN IN INCHES

Figure 12. Nitrogen counter chamber detail.