

AD

CONTRACTOR REPORT ARCCB-CR-96025

**A RAPID METHOD FOR DETERMINING STRESS
CONCENTRATIONS FOR AUTOFRETTAGED
TUBES CONTAINING MULTIPLE AXIAL
PERFORATIONS WITHIN THE WALL**

A. P. PARKER

**ROYAL MILITARY COLLEGE OF SCIENCE
CRANFIELD UNIVERSITY, SWINDON, SN6 8LA, UK**

AUGUST 1996

	<p>US ARMY ARMAMENT RESEARCH, DEVELOPMENT AND ENGINEERING CENTER CLOSE COMBAT ARMAMENTS CENTER BENÉT LABORATORIES WATERVLIET, N.Y. 12189-4050</p>	
---	--	---

APPROVED FOR PUBLIC RELEASE; DISTRIBUTION UNLIMITED

DTIC QUALITY INSPECTED 3

19970108 032

DISCLAIMER

The findings in this report are not to be construed as an official Department of the Army position unless so designated by other authorized documents.

The use of trade name(s) and/or manufacturer(s) does not constitute an official indorsement or approval.

DESTRUCTION NOTICE

For classified documents, follow the procedures in DoD 5200.22-M, Industrial Security Manual, Section II-19 or DoD 5200.1-R, Information Security Program Regulation, Chapter IX.

For unclassified, limited documents, destroy by any method that will prevent disclosure of contents or reconstruction of the document.

For unclassified, unlimited documents, destroy when the report is no longer needed. Do not return it to the originator.

REPORT DOCUMENTATION PAGE

Form Approved
 OMB No. 0704-0188

Public reporting burden for this collection of information is estimated to average 1 hour per response, including the time for reviewing instructions, searching existing data sources, gathering and maintaining the data needed, and completing and reviewing the collection of information. Send comments regarding this burden estimate or any other aspect of this collection of information, including suggestions for reducing the burden, to Washington Headquarters Services, Directorate for Information Operations and Reports, 1215 Jefferson Davis Highway, Suite 1204, Arlington, VA 22202-4302, and to the Office of Management and Budget, Paperwork Reduction Project (0704-0188), Washington, DC 20503.

1. AGENCY USE ONLY (Leave blank) 2. REPORT DATE August 1996 3. REPORT TYPE AND DATES COVERED Final

4. TITLE AND SUBTITLE
A RAPID METHOD FOR DETERMINING STRESS CONCENTRATIONS FOR AUTOFRETTAGED TUBES CONTAINING MULTIPLE AXIAL PERFORATIONS WITHIN THE WALL

5. FUNDING NUMBERS
**European Research Office
 Contract 7922-AN-06(70-1S)**

6. AUTHOR(S)
A.P. Parker

7. PERFORMING ORGANIZATION NAME(S) AND ADDRESS(ES)
**Royal Military College of Science
 Cranfield University
 Swindon, SN6 8LA, UK**

8. PERFORMING ORGANIZATION REPORT NUMBER

9. SPONSORING/MONITORING AGENCY NAME(S) AND ADDRESS(ES)
**U.S. Army ARDEC
 Benet Laboratories, AMSTA-AR-CCB-O
 Watervliet, NY 12189-4050**

10. SPONSORING/MONITORING AGENCY REPORT NUMBER
ARCCB-CR-96025

11. SUPPLEMENTARY NOTES
J.H. Underwood - Benet Laboratories Project Engineer

12a. DISTRIBUTION/AVAILABILITY STATEMENT
Approved for public release; distribution unlimited.

12b. DISTRIBUTION CODE

13. ABSTRACT (Maximum 200 words)

A simple method is developed for the determination of the stress concentration factor (SCF) arising from multiple, periodic, axial, elliptical holes within the wall of a gun tube. The model is based upon a simple superposition procedure with "capping" of any stresses that exceed yield magnitude, and is able to incorporate autofrettage residual stresses.

There are two potential failure locations, namely the bore (radius R_1) and the point on the hole boundary nearest the bore (radius R_H). By plotting the ratio of stress ranges due to firing at these two locations, taking account of pressure entering bore cracks, straightforward design plots of stress range ratio permit the selection of optimum radial hole location. This location is found to vary with the eccentricity of the hole's elliptical shape.

The choice of ideal ellipse eccentricity depends upon R_H , percentage overstrain, and ratio of firing pressure/yield strength. A near optimum value for the case $R_H/R_1 = 1.4$ is provided by the circular hole.

A straightforward design procedure is proposed which requires only standard compendia in order to optimize hole shape.

14. SUBJECT TERMS
Autofrettage, Fatigue Lifetimes, Axial Holes, Channels, Residual Stress, Stress Concentration, Thick Cylinders

15. NUMBER OF PAGES
26

16. PRICE CODE

17. SECURITY CLASSIFICATION OF REPORT
UNCLASSIFIED

18. SECURITY CLASSIFICATION OF THIS PAGE
UNCLASSIFIED

19. SECURITY CLASSIFICATION OF ABSTRACT
UNCLASSIFIED

20. LIMITATION OF ABSTRACT
UL

TABLE OF CONTENTS

	<u>Page</u>
INTRODUCTION	1
MODEL	2
ASSUMED HISTORY	2
ELASTIC BIAXIAL STRESS FIELD EFFECTS	2
RESULTS	6
COMMENTARY	7
REFERENCES	8
APPENDIX	A1

ILLUSTRATIONS

Figure 1	1
Figure 2	3
Figure 3	4
Figure 4	5
Figure 5	5
Figure 6	7

A Rapid Method for Determining Stress Concentrations for Autofrettaged Tubes Containing Multiple Axial Perforations Within the Wall

A P Parker

INTRODUCTION

The use of autofrettage to enhance fatigue lifetimes of thick cylinders subjected to internal cyclic pressurization is well known and relatively well understood. Recent work has addressed the problems associated with geometrical changes which remove the initial axi-symmetric nature of geometry and stressing of these tubes, namely:

- a. Axial erosion grooves, which arise after autofrettage, along the bore of the cylinder, Ref 1.
- b. Cross-bore holes normal to the tube axis (Ref 2) and inclined at an angle to the axis (Ref 3). These holes likewise are introduced after autofrettage.

The purpose of the work presented herein is to analyze, using elastic and simplified elastic/plastic stress analysis methods, the fatigue behaviour of cylinders which contain a series of equally-spaced holes orientated parallel to the tube axis and which were introduced prior to autofrettage. The cross-sectional shape of these holes may be somewhat arbitrary, but is shown diagrammatically in Figure 1 as circular.

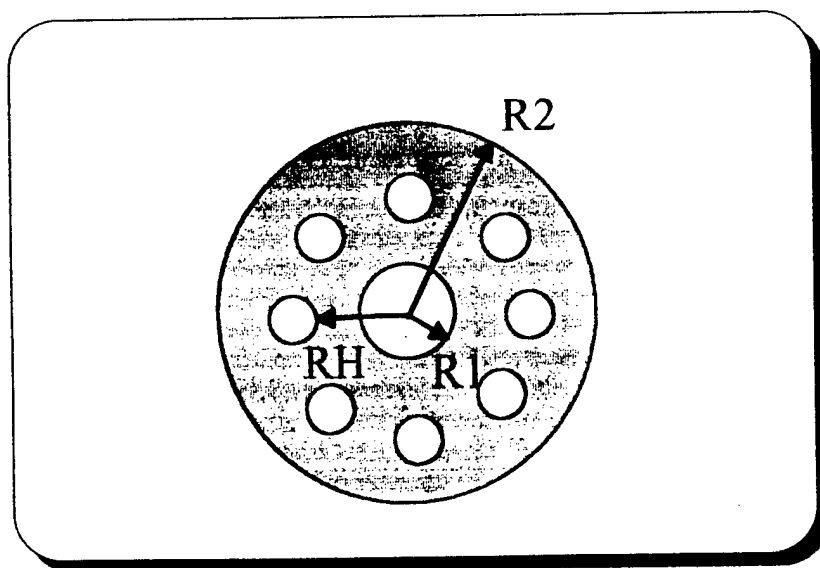

Figure 1

MODEL

The model is summarised below (refer to Figure 1).

- a. Tube radius ratio $R_2/R_1 = 2.0$ and 1.8
- b. One or 24 arbitrarily shaped cooling holes with critical locations at radius R_H
- c. Cooling hole size small relative to tube radii
- d. Cooling hole size significant relative to hole spacing (multiple cooling holes)
- e. Tresca yield criterion applies. If stress at any location exceeds yield, whether in tension or compression, loading or unloading, it is capped at yield magnitude
- f. The following variables and associated ranges were examined:

$$1.0 \leq R_H/R_1 \leq R_2/R_1$$

$$K_T^{(1)} = 1.5, 2.0, 2.5, 3.0, 3.5, 4.0$$

where $K_T^{(1)}$ is conventional stress concentration factor (uniaxial tension)

$$\%Autofrettage = 0, 30, 40, 50, 60, 70, 80, 90, 100$$

$$\text{Firing Pressure } (p^f) = 33\% \text{ and } 40\% \text{ of Yield Strength}$$

ASSUMED HISTORY

Zero interference fit between inner and outer tube ('neat fit')

Case 1 : No autofrettage, possible yielding at hole during first firing (capped at yield magnitude) followed by elastic unloading

Case 2 : Autofrettage, yielding at hole during loading (capped at yield magnitude in tension) and possibly during removal of autofrettage pressure (again, capped at yield magnitude in compression).

Assume 70% of 'ideal' autofrettage field locked in at bore (this encompasses Bauschinger effect)

ELASTIC BIAXIAL STRESS FIELD EFFECTS

Radial (σ_r) and Hoop (σ_θ) stresses generated by the application of internal pressure are perceived by the hole(s) as a biaxial stress field. It is important to understand the stress concentration effects around a circular or elliptical cut-out in a biaxial stress field.. This is illustrated in Figure 2 for the case of a single elliptical cut-out having major axis $2a$ and minor axis $2b$ with principal stresses σ_1 and σ_2 applied normal to the axes of the ellipse. We note later that σ_1 and σ_2 are analogous to σ_θ and σ_r respectively.

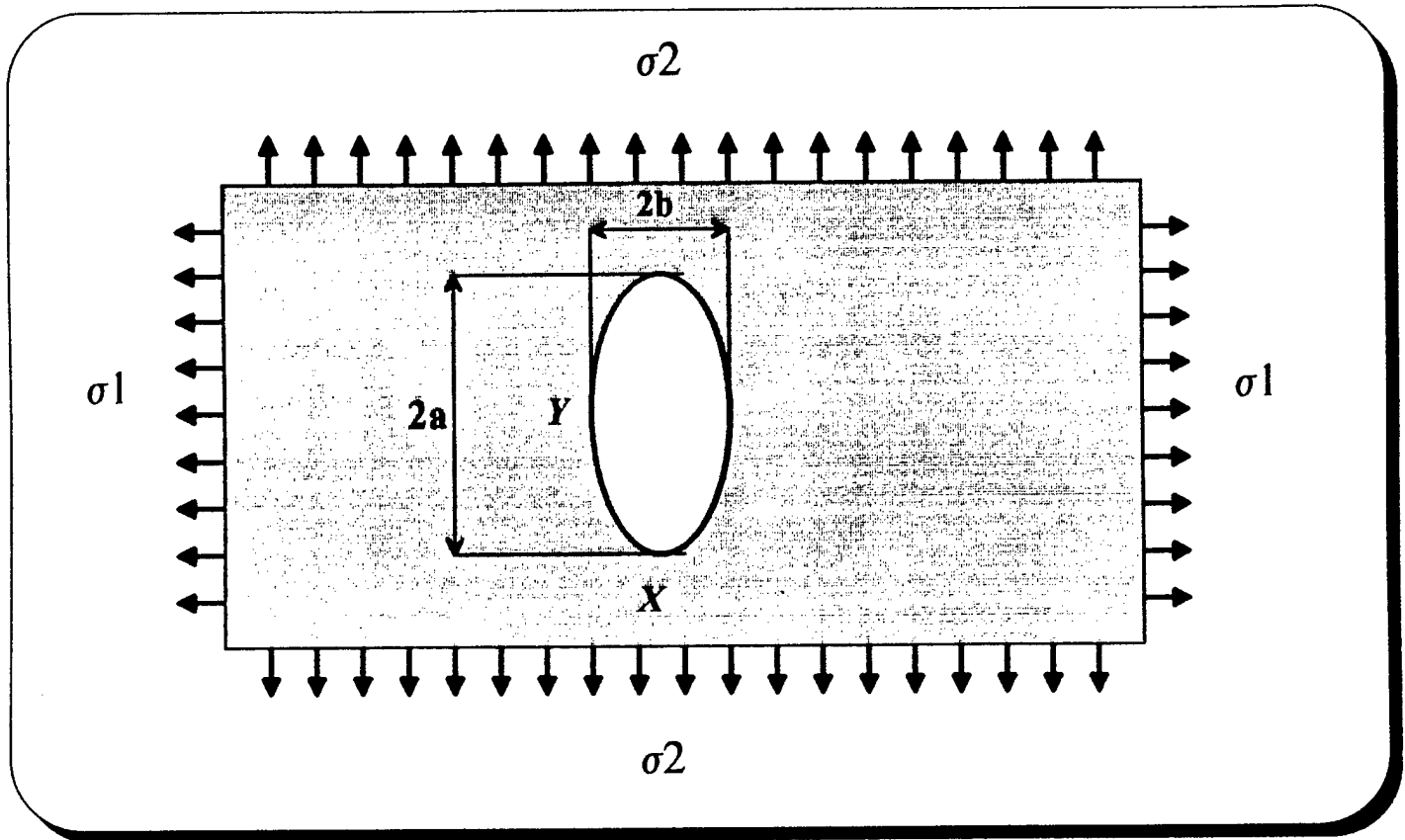

Figure 2

The Maximum Principal Stress at point X is given by:

$$\alpha \left[1 + 2 \left[\frac{a}{b} \right] \right] \sigma_1 - \beta \delta \sigma_1 \quad (1)$$

where $\delta = \frac{\sigma_2}{\sigma_1}$

and we designate $K_T^{(1)} = \alpha \left[1 + 2 \left[\frac{a}{b} \right] \right]$ (2)

and $K_T^{(2)} = -\beta \delta$ (3)

and for later use $K_T^{(T)} = K_T^{(1)} + K_T^{(2)}$ (4)

where, for a single hole $\alpha = \beta = 1$.

For the case $a = b$, $\sigma_2 = 0$ this reduces to the familiar stress concentration factor for a circular hole, of value +3.

Now consider the effect of creating an infinite array of such holes (Figure 3), with spacing of $2d$ between centers. There is then a rearrangement of the stress patterns and a modification of the stress concentration factor in that α and β are liable to change.

Turning first to β , the value of unity is the analytic solution for :

- A single ellipse (including the special case of a circle)
- An infinite array of cracks (i.e. $a = 0$, all physically acceptable values of d)

it is therefore inferred that the value of $\beta = \text{unity}$ applies to the case of a single ellipse and to an array of ellipses. In any case, as will be demonstrated later, the magnitude of the hoop stresses is much greater than the radial stresses and therefore any errors in β will be relatively insignificant.

It is possible to obtain values of α from a compendium of stress concentration factors due to Peterson (1974), Ref 4. The relevant results presented therein summarise the work of Nisitani (1968), Ref 5 and Schulz (1942, 1943-1945), Ref 6. Unfortunately the results are only presented for the case $a \geq b$, which includes the case of the circle. These results are also further restricted to $0 \leq a/d \leq 0.75$ (for $a = b$) and $0 \leq a/d \leq 0.5$ (for $a > b$).

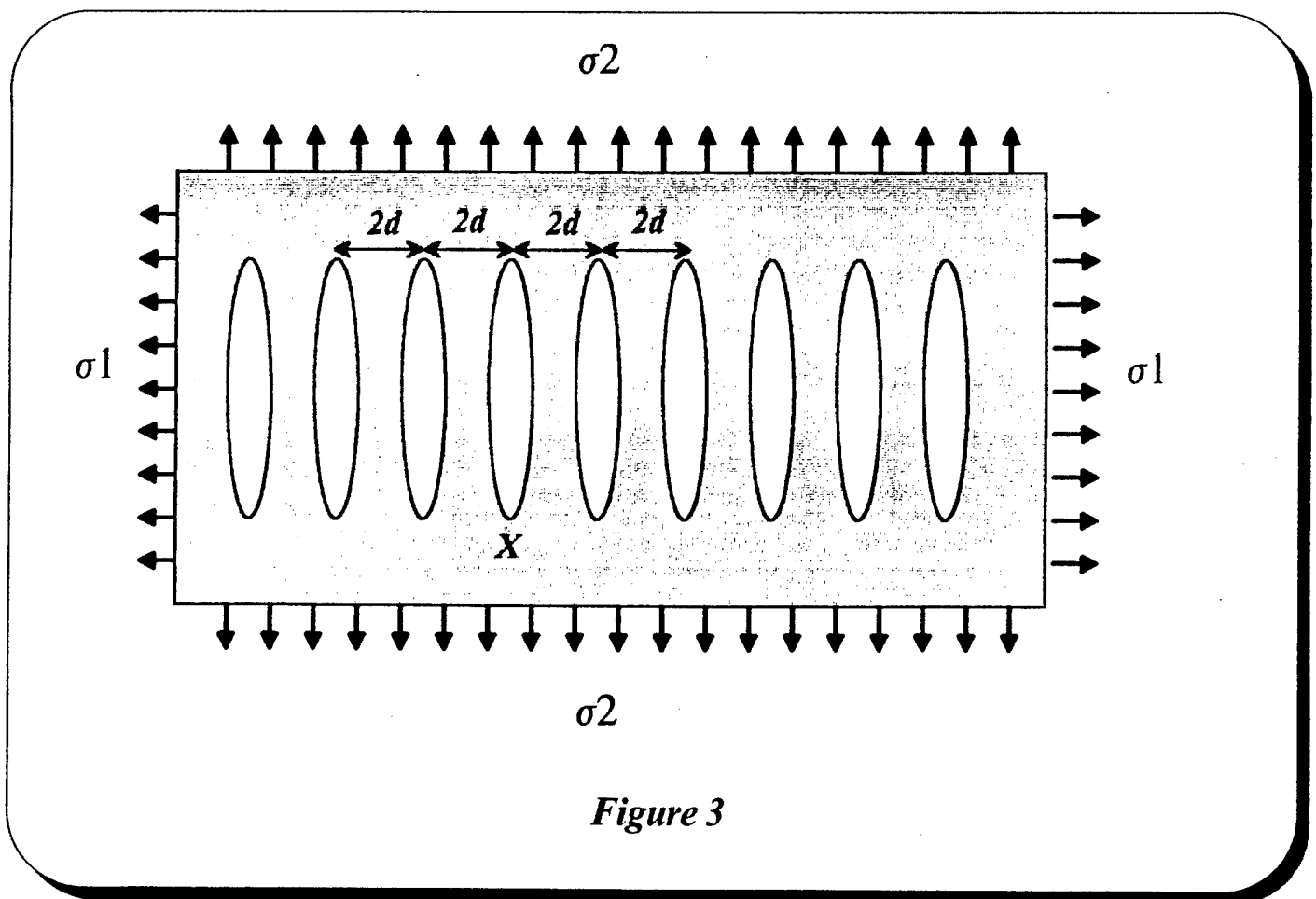

Figure 3

Turning to the particular case of an array of 24 circular holes ($a = b$) conforming with the general geometry shown in Figure 4 we find that $a/d = b/d = 0.425$, giving (from Peterson) a value $\alpha = 0.76$ (note this figure can be obtained from Peterson, Fig 113, Fig 134 or Fig 135). Hence the single circular hole uniaxial SCF value ($K_T^{(1)}$) of +3 is reduced to 2.28, whilst β remains at unity. Values of α for the circular hole and $0 \leq a/d \leq 0.75$ are reproduced as Figure 5 directly from Peterson (Fig 113).

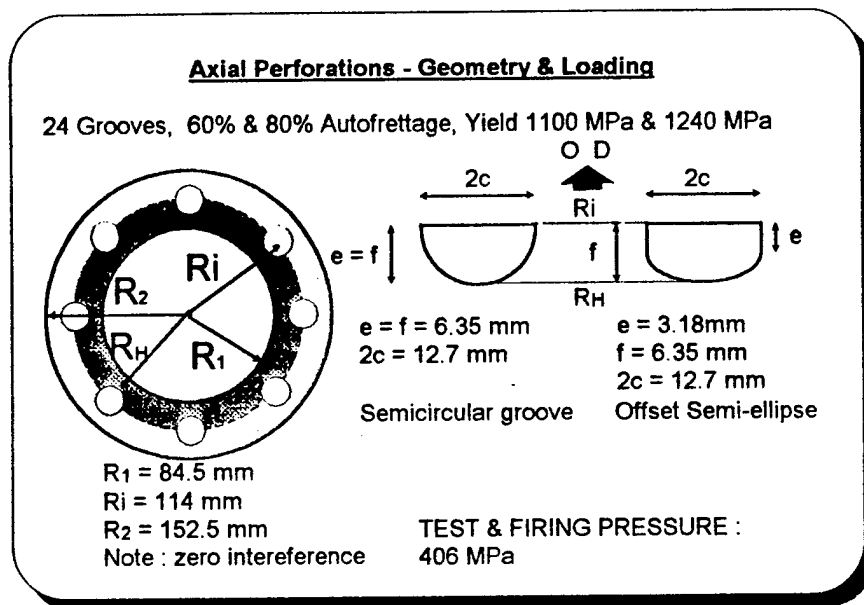

Figure 4

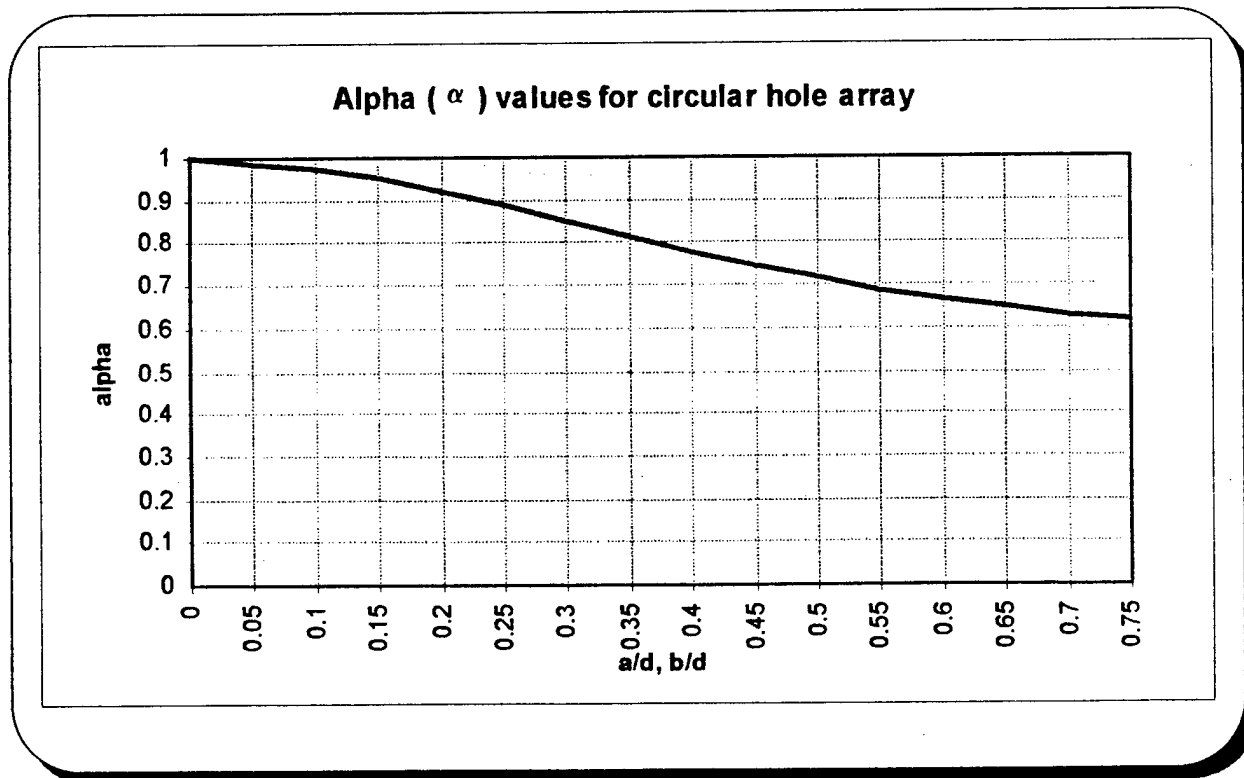

Figure 5

Now maintaining a b/d ratio of 0.425 and allowing a/b to vary we find that when

a/b = 2	we obtain	a/d = 0.85
a/b = 0.5	we obtain	a/d = 0.2125

Using Peterson, Fig 134, we find that for the case a/b = 2, using a/d = 0.85, a value $\alpha = 0.69$ is extrapolated; this gives a uniaxial SCF of $(0.69 \times (1 + 2 \times (a/b)))$ or 3.45. Whilst data are not presented for the case $a < b$ it is possible to infer some approximate values using Peterson, Fig 134. On this basis, using a/d = 0.2125, a value $\alpha = 0.87$ is obtained for a/b = 0.5, this gives a uniaxial SCF of $(0.87 \times (1 + 2 \times (a/b)))$ or 1.74. The inference is clear: whilst the 'shielding' effect does reduce SCF proportionately more with increasing a/b, this effect is not sufficient to prevent the significant increase of SCF with increasing a/b ratio.

At this point we note that σ_1 and σ_2 are analogous to σ_θ and σ_r respectively, and that since the latter are of opposite sign as a result of internal pressure, the existence of the minus sign in Equation (1) means that the effects on the total SCF ($K_T^{(T)}$) are additive.

RESULTS

The results are presented in dimensionless form. Since a major objective is likely to be to optimise the design to produce similar positive cyclic stress ranges at both bore ($\Delta\sigma^B$) and hole ($\Delta\sigma^H$) the main parameter considered is the ratio $\Delta\sigma^H/\Delta\sigma^B$, designated R Δ . This ratio is presented numerically and graphically in Appendix A. (Note: this approach is described at length in Reference 7)

NOTE THAT THE ABBREVIATION cSCF USED ON ALL PLOTS INDICATES CONVENTIONAL STRESS CONCENTRATION FACTOR, i.e. $K_T^{(T)}$ IN THE DEFINITIONS USED HEREIN. IN ALL CASES THE CURVES IMPLICITLY TAKE ACCOUNT OF THE CONTRIBUTION FROM RADIAL STRESSES AT THE GIVEN RADIAL LOCATION.

Case 1 - R2/R1 = 2.0

Pages A1 - A9 show the R Δ ratio ($\Delta\sigma^H/\Delta\sigma^B$) for a non-autofrettaged tube and for tubes with various percentage overstrains. The results for 60% autofrettage are shown further enlarged by restricting to $1.2 < RH/R1 < R2/R1$ and also plotted as SCF versus R Δ ratio which permits the easy location of minima for any value of RH/R1.

Case 2 - R2/R1 = 1.8

Pages A10 - A17 show the R Δ ratio for tubes with various percentage overstrains. The results for 60% autofrettage are shown further enlarged by restricting to $1.2 < RH/R1 < R2/R1$ and also plotted as SCF versus R Δ ratio which permits the easy location of minima for any value of RH/R1.

COMMENTARY

Referring to Appendix A we note some interesting features.

- a. The choice of ideal $K_T^{(1)}$ depends upon $RH/R1$, percentage overstrain and ratio of Firing pressure/Yield strength
- b. For the case $RH/R1 = 1.4$ the single circular hole ($K_T^{(1)} = 3$) produces a near optimum value.
- c. For the case $RH/R1 = 1.4$, reducing $K_T^{(1)}$ below 3.0 invariably results in a detrimental increase in $R\Delta$
- d. In order to determine the optimum groove shape using only standard stress concentration manuals the following steps are necessary:
 - ◆ Identify minimum $R\Delta$ and associated $K_T^{(1)}$ for relevant $R2/R1$ and $RH/R1$
 - ◆ Using Peterson calculate value of α for number of holes and hole size
 - ◆ Use SCF and α in Equation (1) to determine optimum ellipse eccentricity

It is important to note that the above approach can also be applied to arbitrary groove shapes by undertaking a straightforward, two-dimensional, numerical elastic stress analysis. In this case the arbitrary groove shape is modelled using (say) FE or BE methods, Figure 6, with internal pressure applied to the bore and $u_\theta = \tau_{r\theta} = 0$ along radii of symmetry. The value of $K_T^{(1)}$ being extracted for the critical point on the hole boundary. This requires a set of design curves based upon $K_T^{(1)}$ rather than $K_T^{(1)}$.

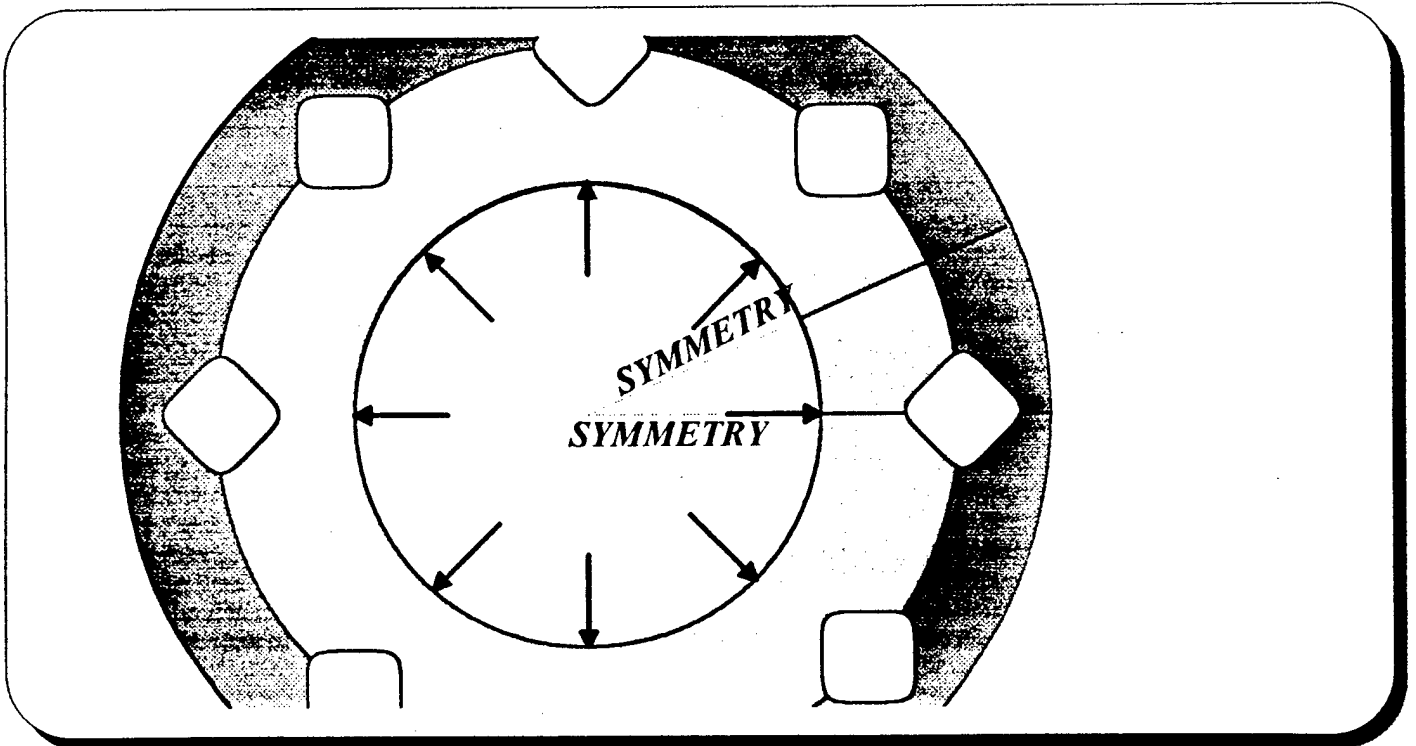
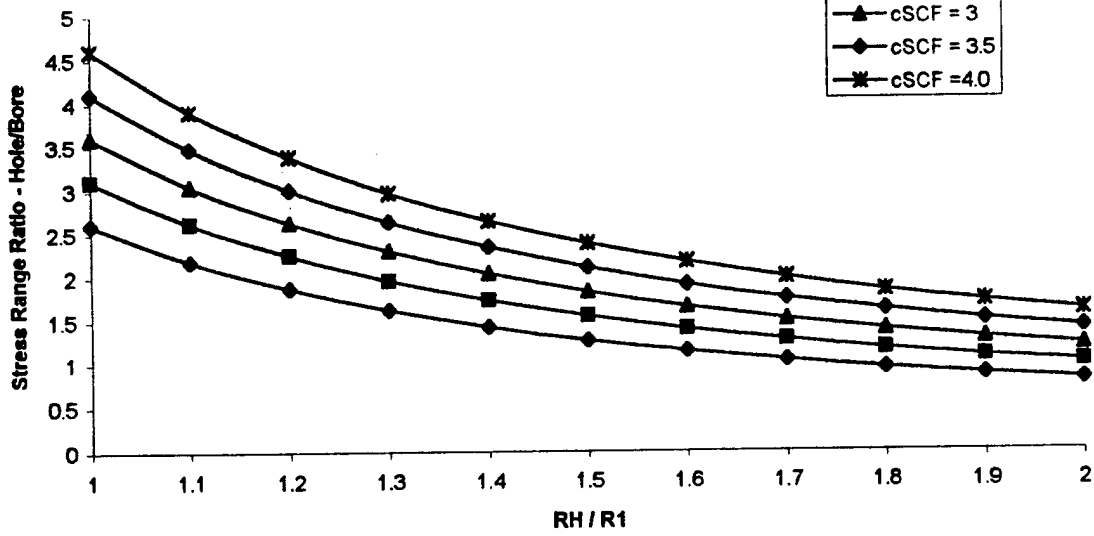

Figure 6

REFERENCES

1. Underwood, J H, and Parker, A P, *Fatigue Life Analysis and Tests for Thick-Walled Cylinders Including Effects of Overstrain and Axial Grooves*, PVP-Vol 280, Fatigue, Flaw Evaluation and Leak-Before-Break Assessments, ASME PVP Conference Proceedings, pp303-311, Minneapolis, 1994 . Published in Trans ASME PVP Journal, Vol 117, pp222-226 (1995)
2. Parker, A P and Underwood, J H, *Stress Concentration, Stress Intensity and Fatigue Crack Growth Along Evacuators of Pressurized, Autofrettaged Tubes*, ASME PVP Conference Proceedings, Hawaii, 1995 (In Press)(Accepted for publication in ASME PVP Journal, 1995)
3. Endersby, S, Bond, T and Parker A P, *Stress Concentration, Stress Intensity and Fatigue Crack Growth Along Angled Evacuators of Pressurized, Autofrettaged Tubes*, (In preparation for publication, 1995)
4. Peterson, R E, *Stress Concentration Factors*, Wiley (1974)
5. Nisitani, H, *Method of Approximate Calculation for Interference of Notch Effect and its Application*, Bull Japan Soc Mech Eng, 11, p725 (1968)
6. Schulz, K J, *On the State of Stress in Perforated Strips and Plates*, Proc Koninklyke Nederlandsche Akadamie van Wetenschappen (Netherlands Royal Academy of Science), Amsterdam, (6 papers) Vol 45, pp233, 341, 457, 524 (1942) Vol 46-48, pp 282, 292 (1943-45)
7. Parker, A P, Underwood, J H, *Some Methods of Representing Fatigue Lifetime as a Function of Stress Range and Initial Crack Length*, To be presented at ASTM National Fracture Symposium, Saratoga Springs, NY June 1996 and published in ASTM STP American Society for Testing and Materials. Philadelphia, (1996)

Zero Autofrettage, $R2/R1 = 2.0$
No 'Capping' of Stresses



Zero Autofrettage, $R2/R1 = 2.0$
No 'Capping' of Stresses

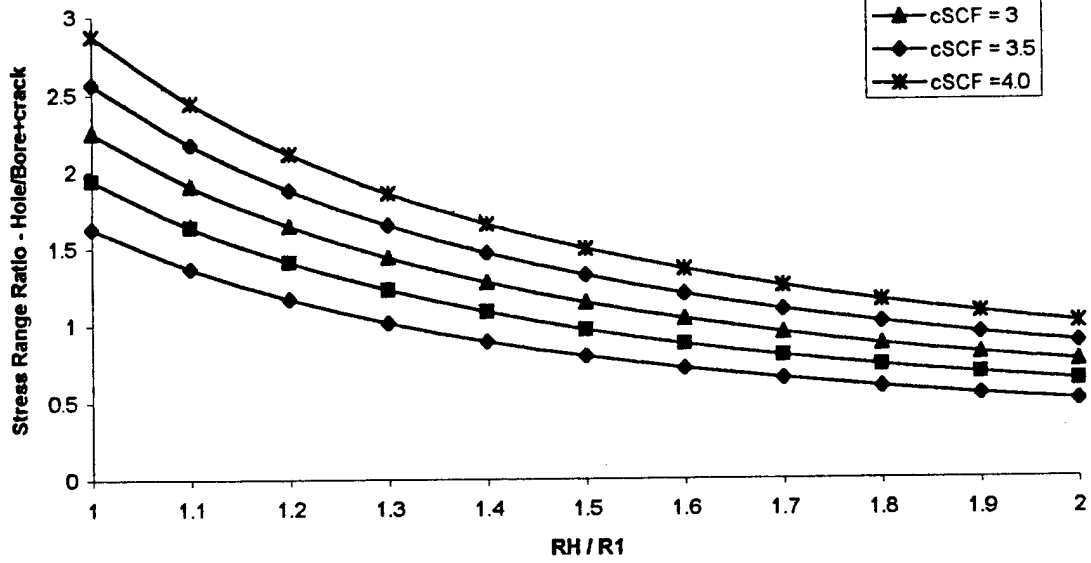

30% Autofrettage, R2/R1 = 2.0, pf/Y=0.4

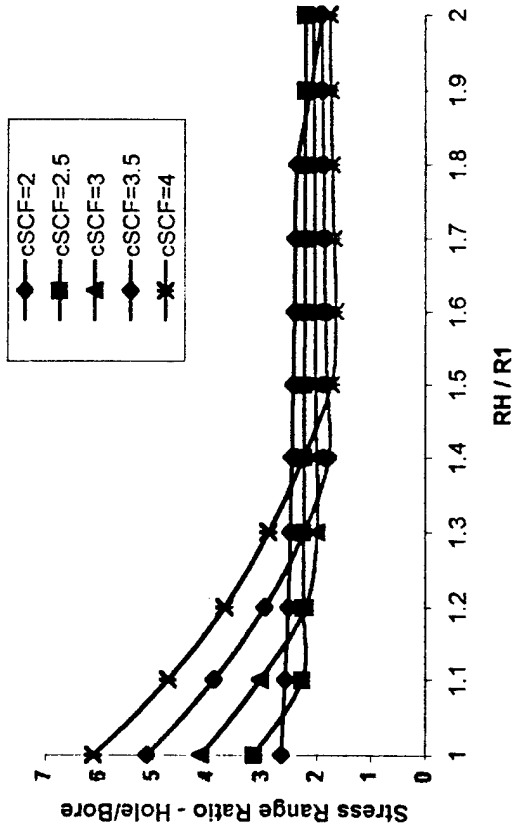

40% Autofrettage, R2/R1 = 2.0, pf/Y=0.4

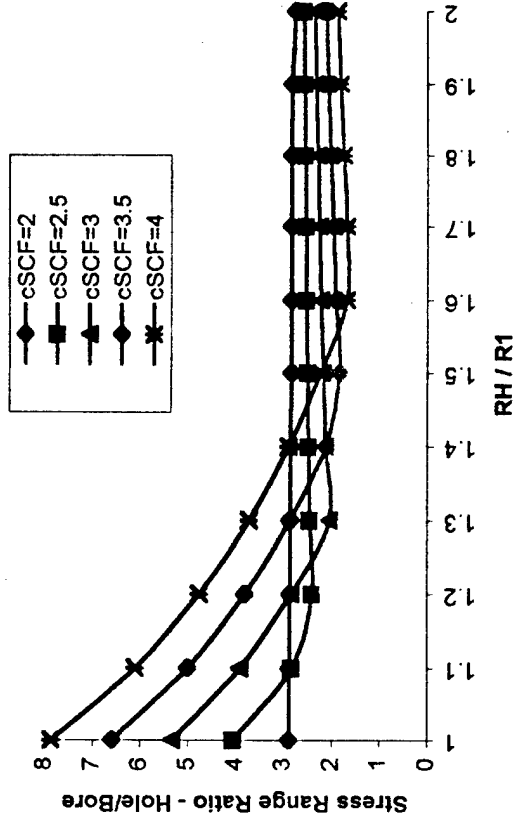

50% Autofrettage, R2/R1 = 2.0, pf/Y=0.4

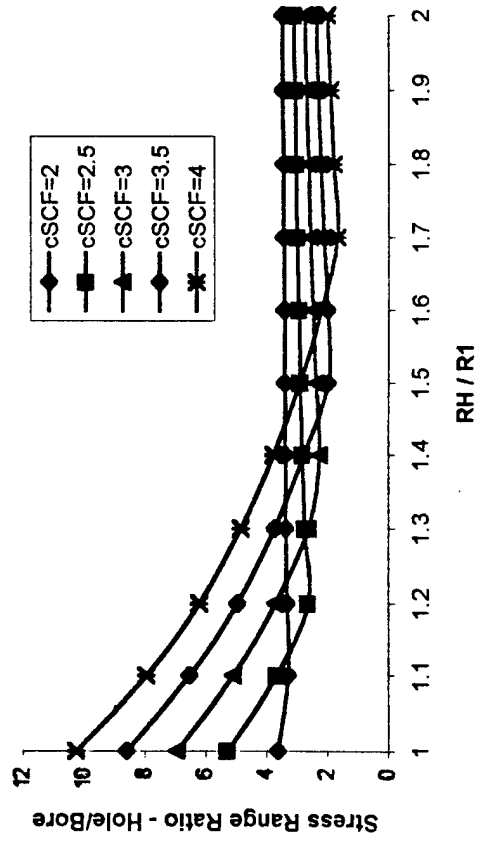

60% Autofrettage, R2/R1 = 2.0, pf/Y=0.4

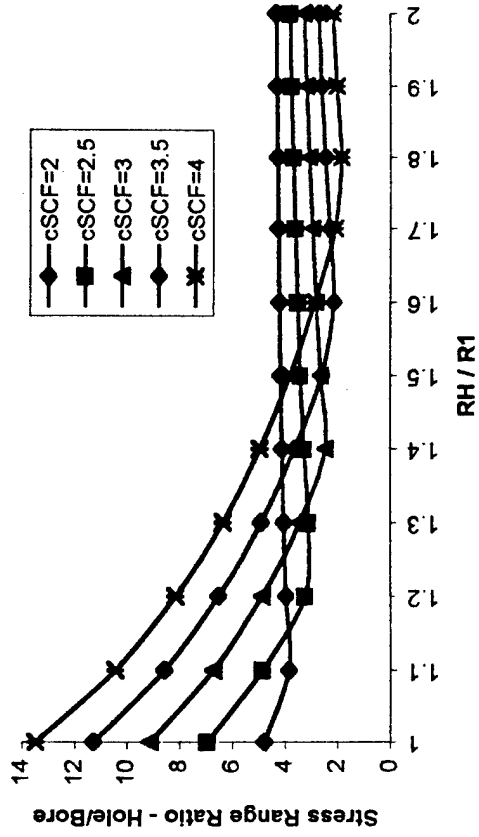

70% Autofrettage, R2/R1 = 2.0, pf/Y=0.4

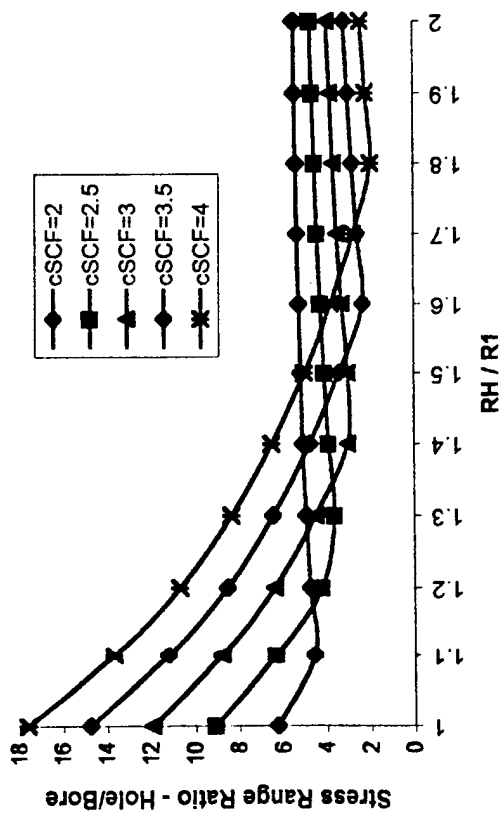

80% Autofrettage, R2/R1 = 2.0, pf/Y=0.4

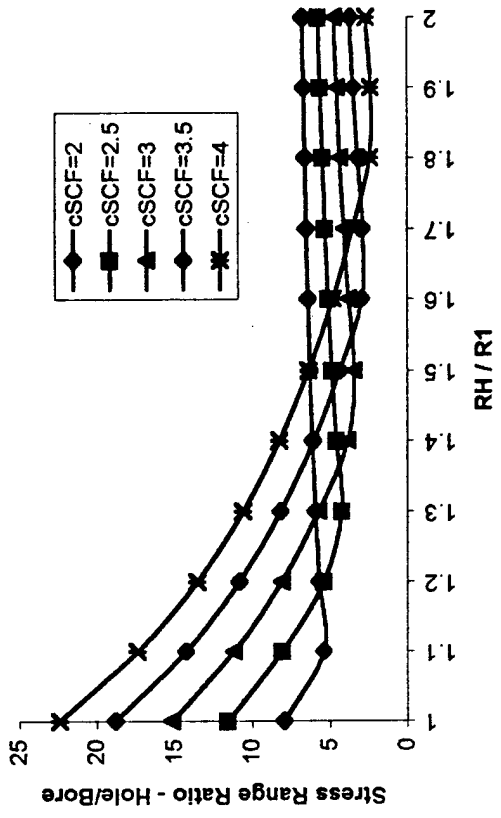

60% Autofrettage, R2/R1 = 2.0, pf/Y=0.4

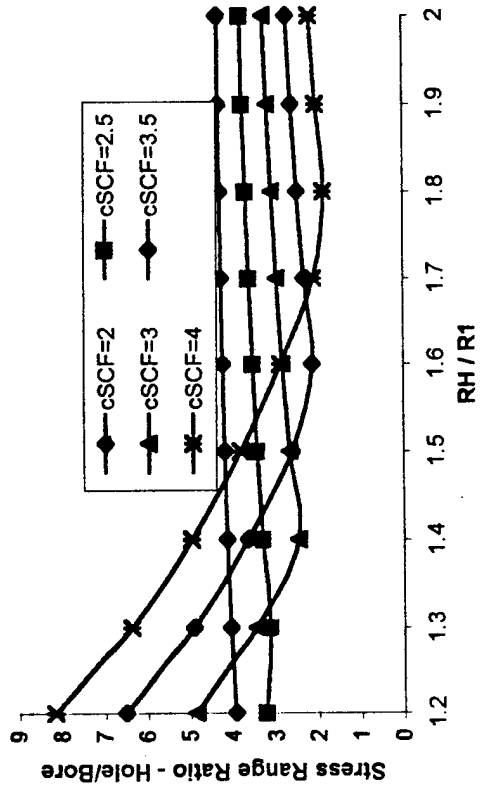

60% Autofrettage, R2/R1 = 2.0, pf/Y=0.4

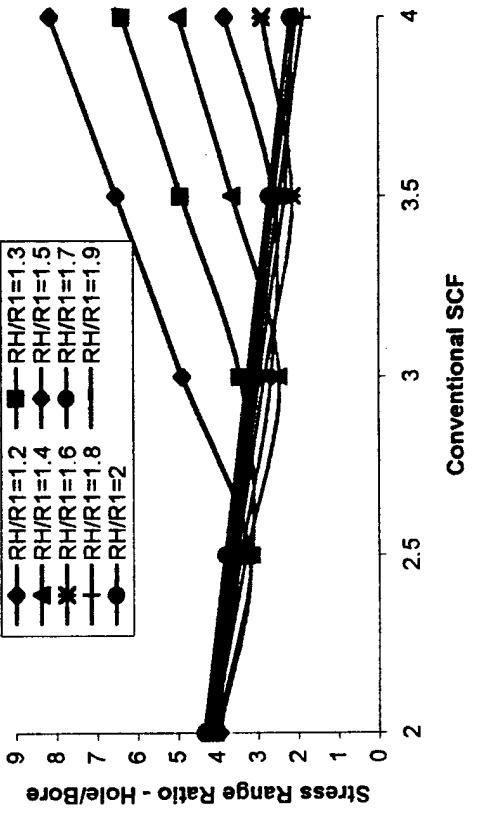

30% Autofrettage, R2/R1 = 2.0, pf/Y=0.4

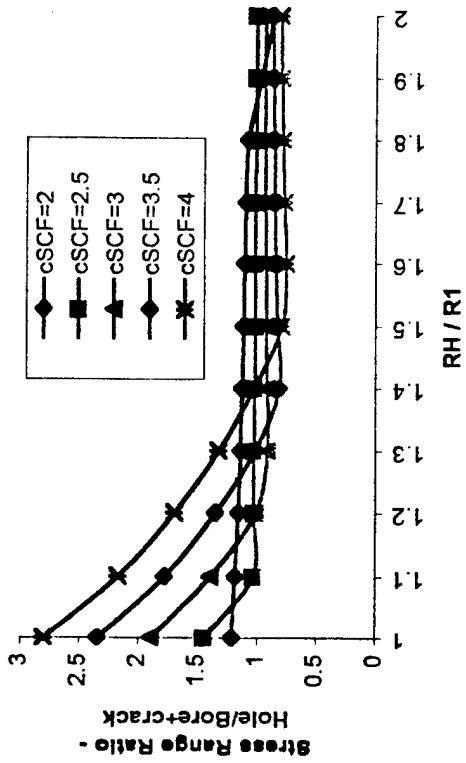

40% Autofrettage, R2/R1 = 2.0, pf/Y=0.4

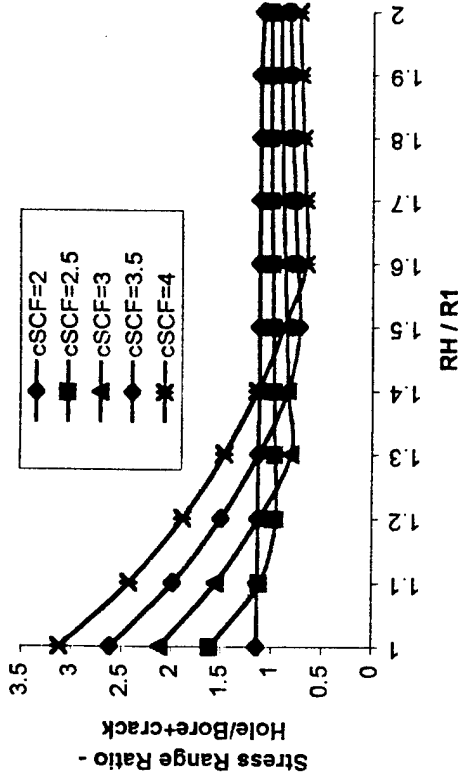

50% Autofrettage, R2/R1 = 2.0, pf/Y=0.4

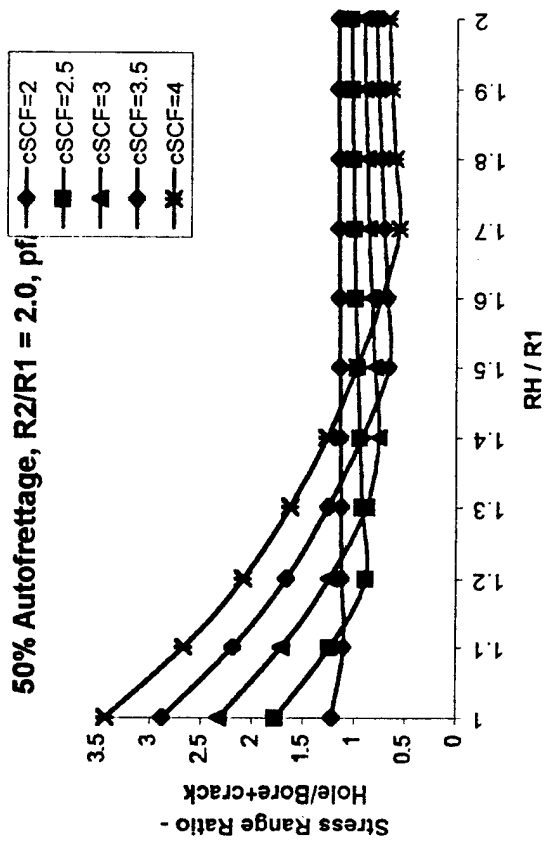

60% Autofrettage, R2/R1 = 2.0, pf/Y=0.4

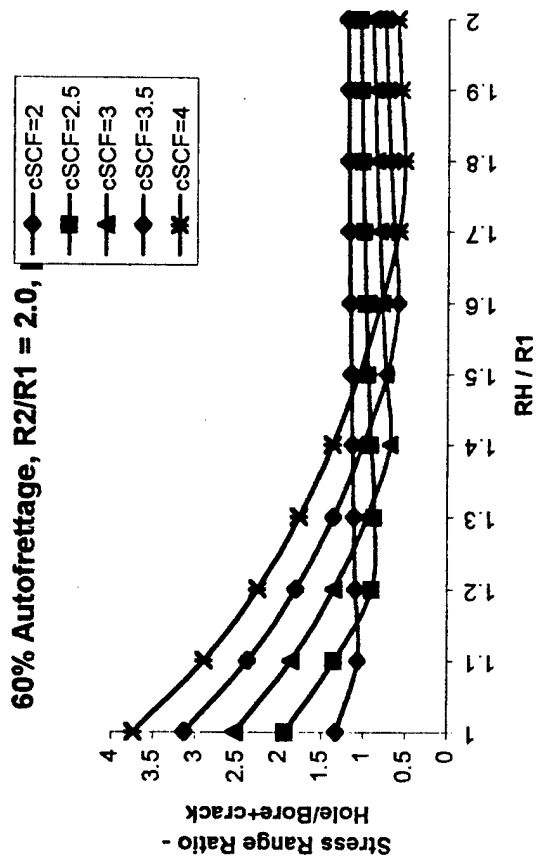

70% Autofrettage, R2/R1 = 2.0, pf/Y=0.4

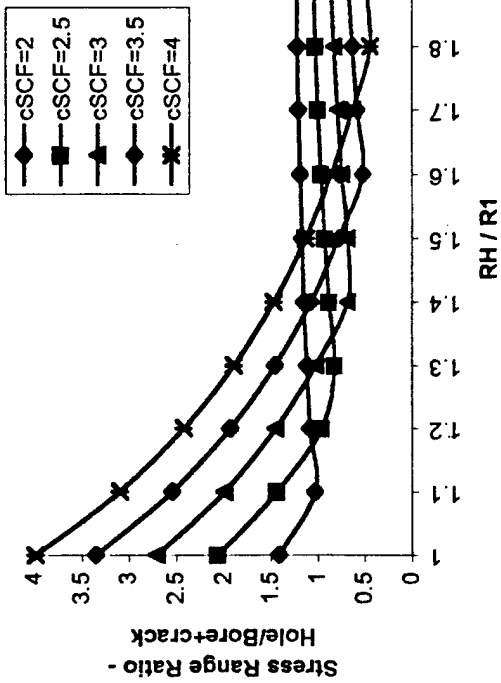

80% Autofrettage, R2/R1 = 2.0, pf/Y=0.4

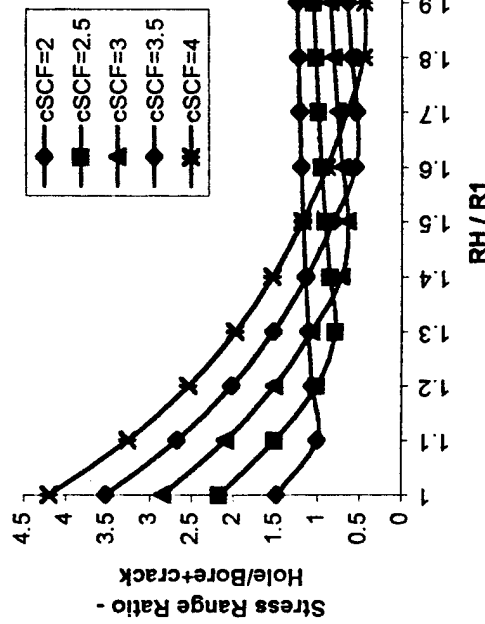

60% Autofrettage, R2/R1 = 2.0, pf/Y=0.4

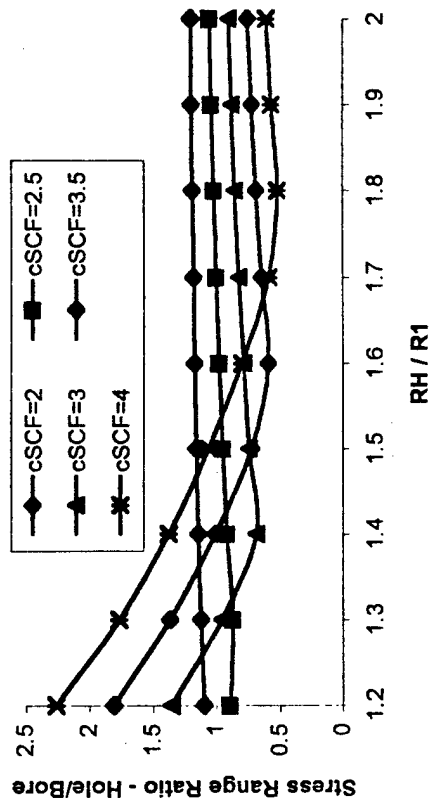

60% Autofrettage, R2/R1 = 2.0, pf/Y=0.4

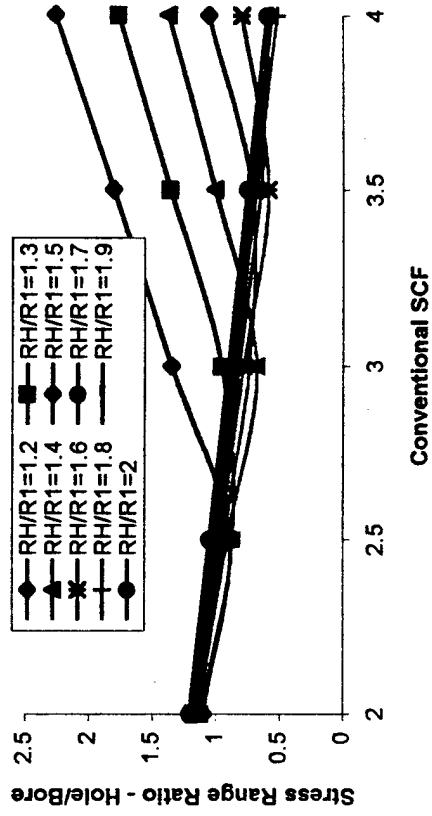

30% Autofrettage, R2/R1 = 2.0, pf/Y=0.333

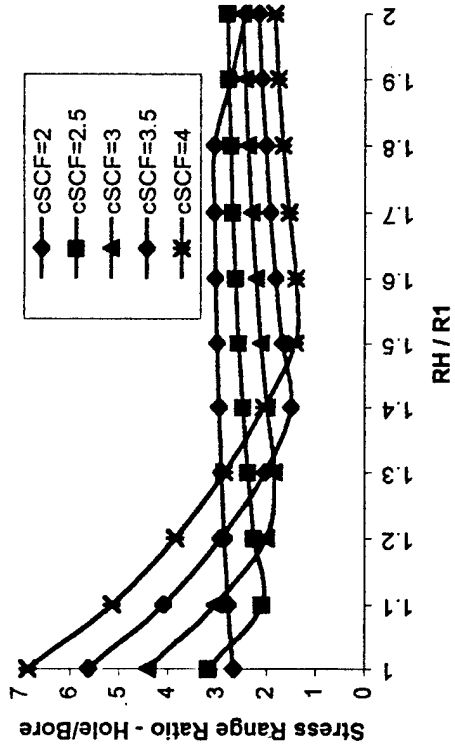

40% Autofrettage, R2/R1 = 2.0, pf/Y=0.333

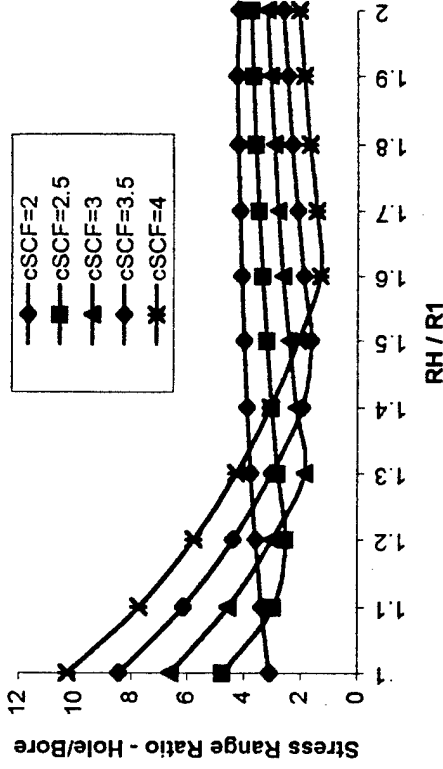

50% Autofrettage, R2/R1 = 2.0, pf/Y=0.333

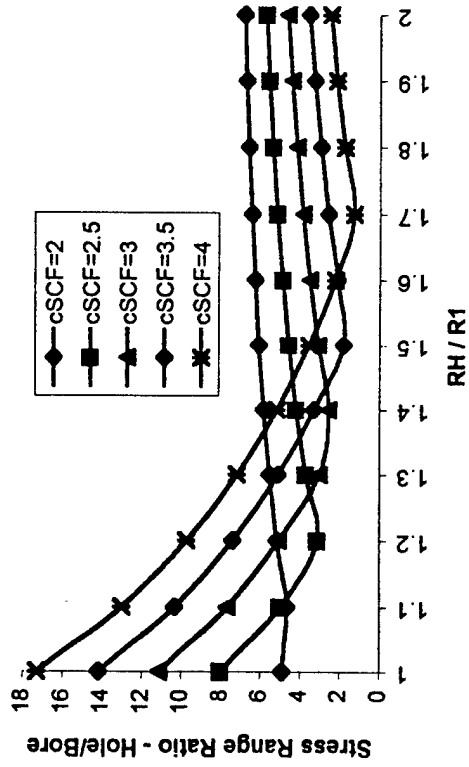

60% Autofrettage, R2/R1 = 2.0, pf/Y=0.333

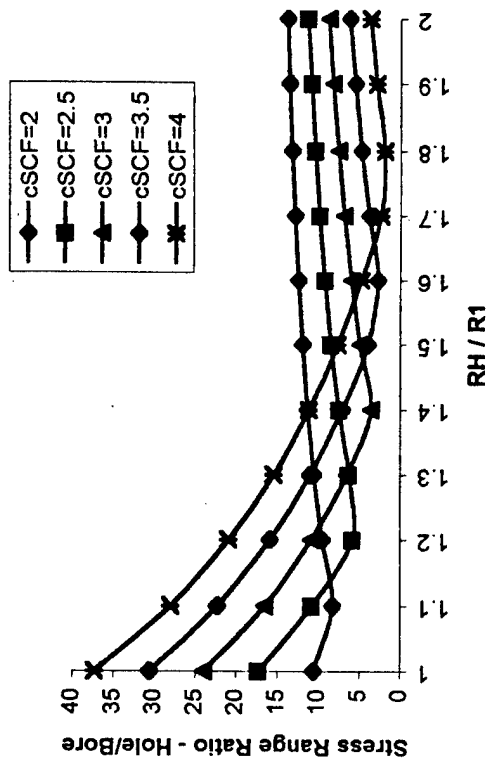

70% Autofrettage, R2/R1 = 2.0, pf/Y

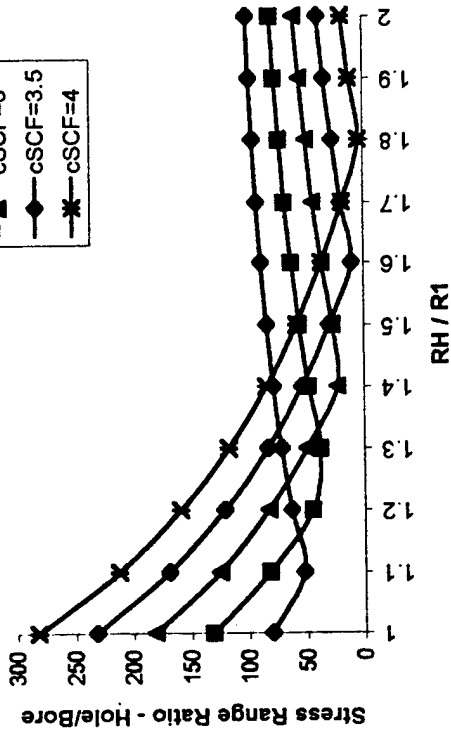

60% Autofrettage, R2/R1 = 2.0, pf/Y=0.333

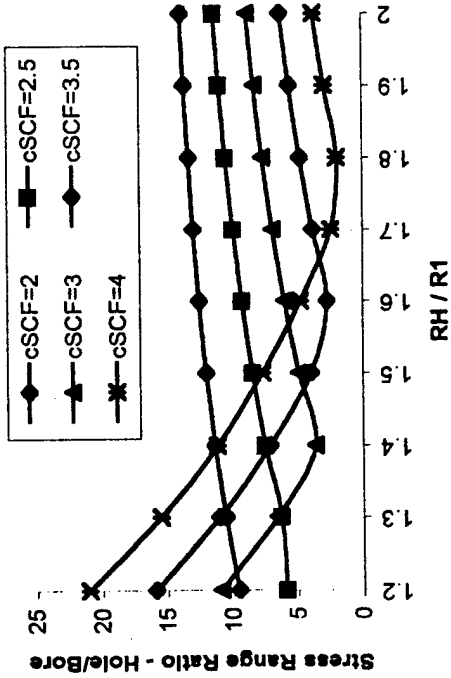

60% Autofrettage, R2/R1 = 2.0, pf/Y=0.333

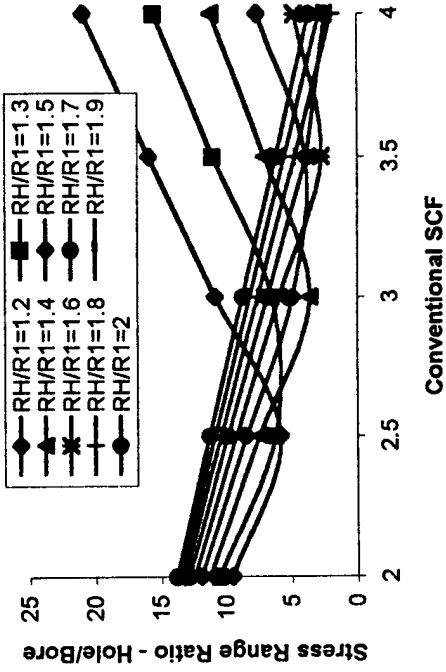

30% Autofrettage, $R2/R1 = 2.0$, $pf/Y = 0.333$

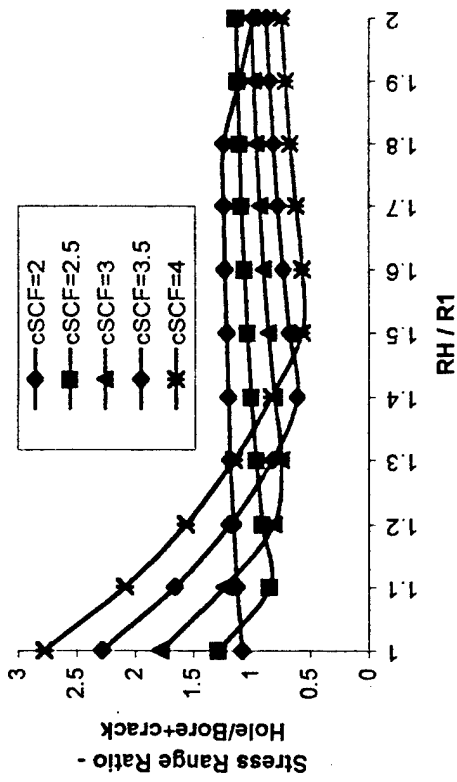

40% Autofrettage, $R2/R1 = 2.0$, $pf/Y = 0.333$

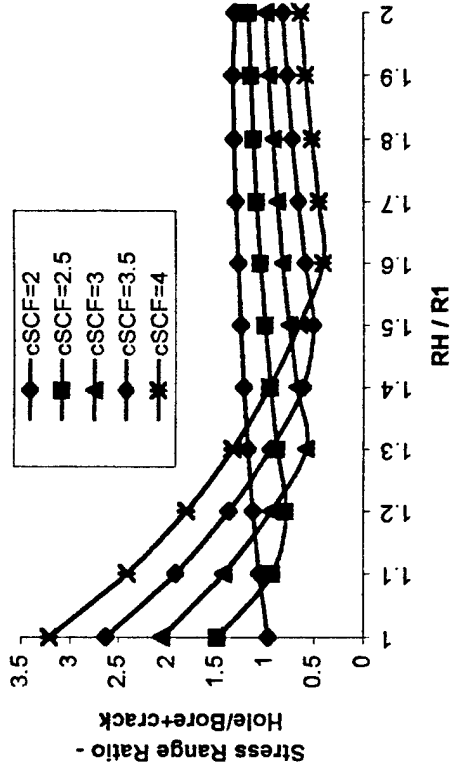

50% Autofrettage, $R2/R1 = 2.0$, $pf/Y = 0.333$

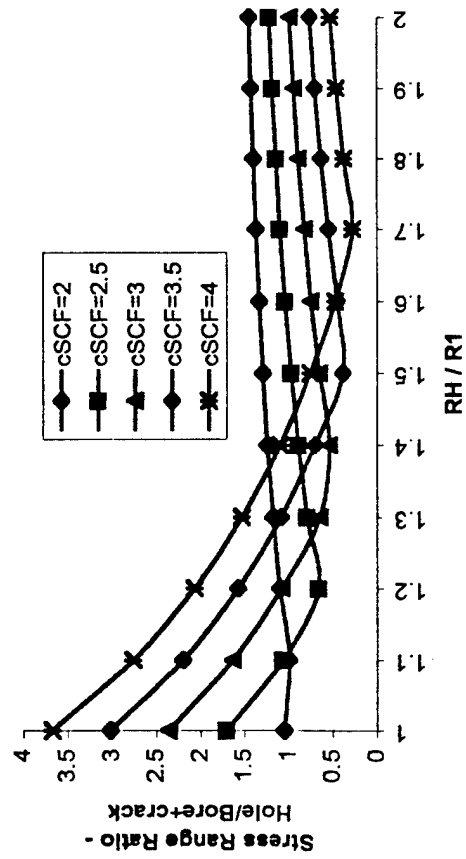

60% Autofrettage, $R2/R1 = 2.0$, $pf/Y = 0.333$

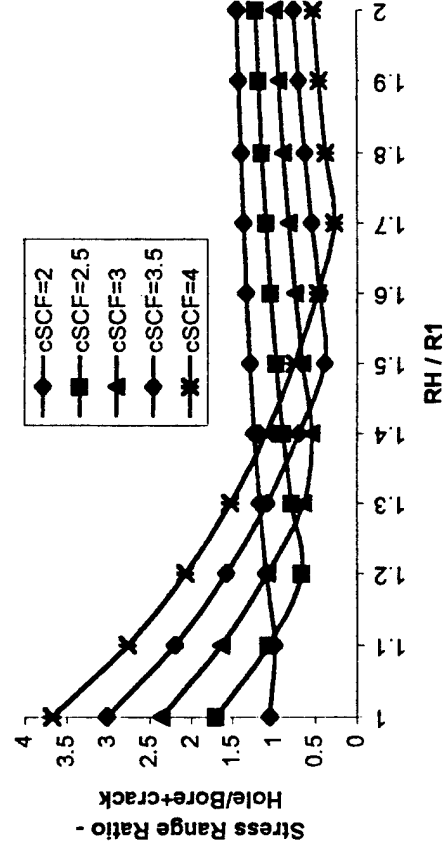

70% Autofrettage, R2/R1 = 2.0, pf/Y=0.333

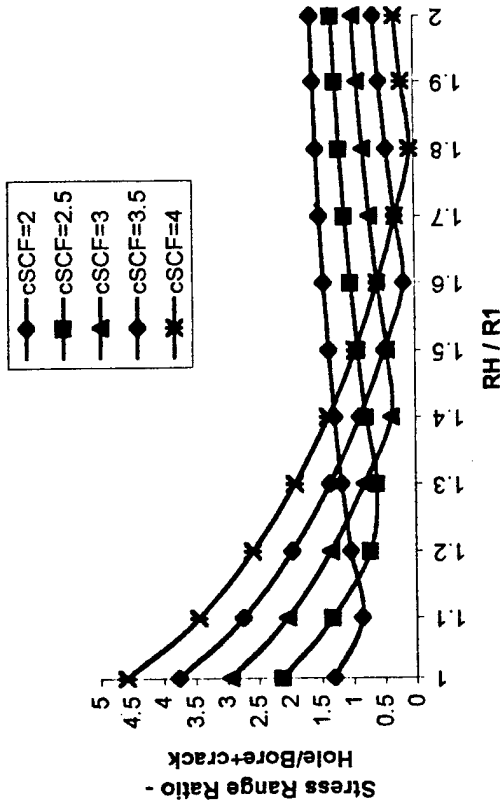

60% Autofrettage, R2/R1 = 2.0, pf/Y=0.333

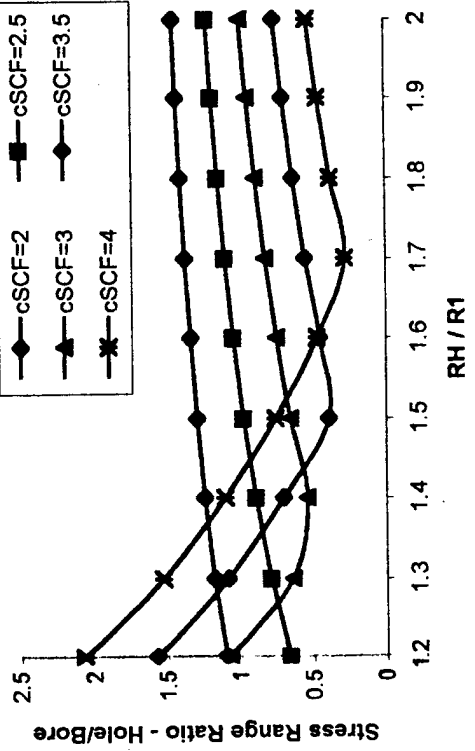

80% Autofrettage, R2/R1 = 2.0, pf/Y=0.333

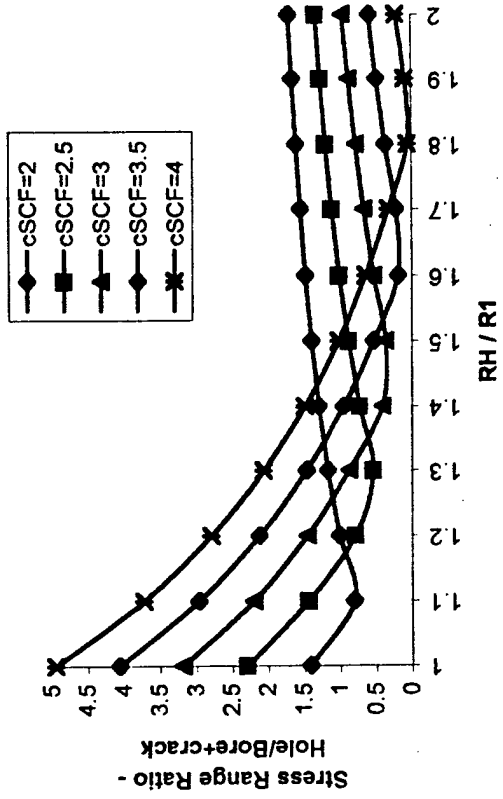

60% Autofrettage, R2/R1 = 2.0, pf/Y=0.333

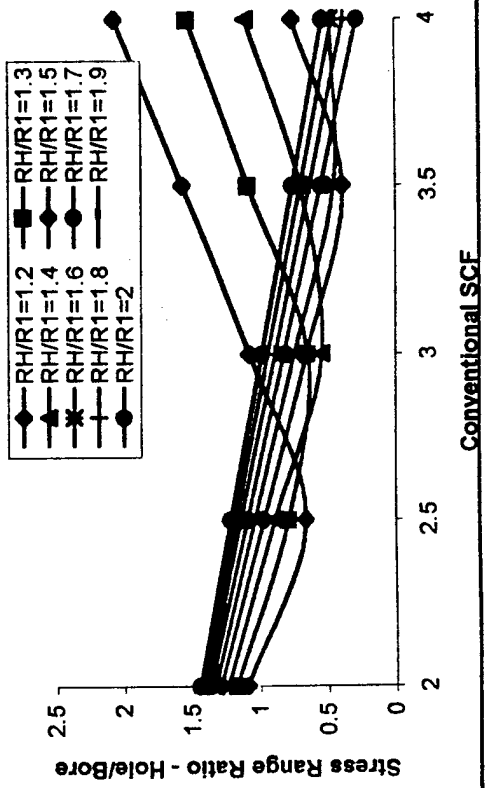

30% Autofrettage, R2/R1 = 1.8, pf/Y=0.4

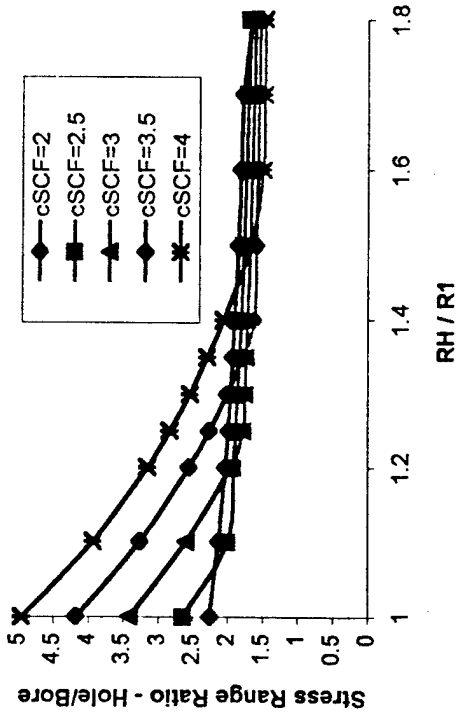

40% Autofrettage, R2/R1 = 1.8, pf/Y=0.4

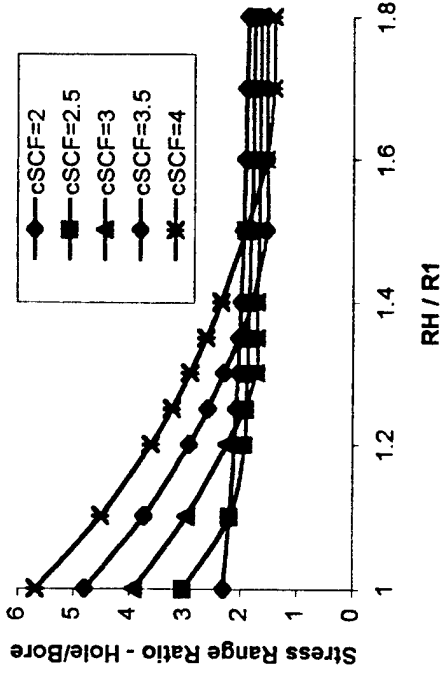

50% Autofrettage, R2/R1 = 1.8, pf/Y=0.4

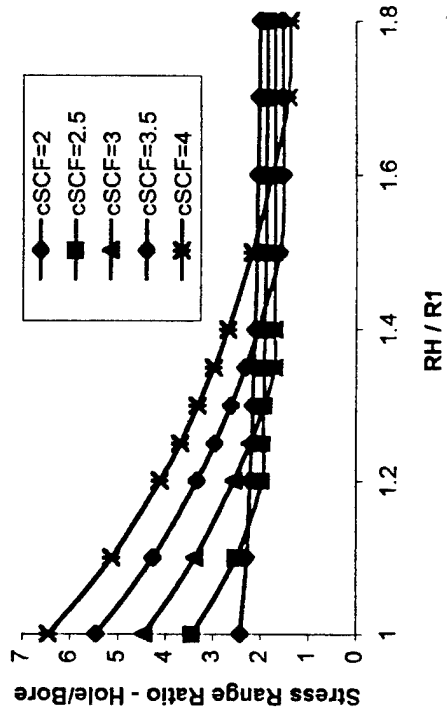

60% Autofrettage, R2/R1 = 1.8, pf/Y=0.4

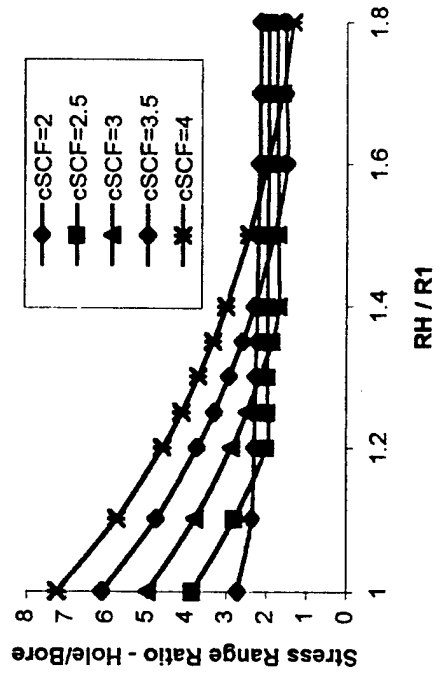

80% Autofrettage, $R2/R1 = 1.8$, $pf/Y=0.4$

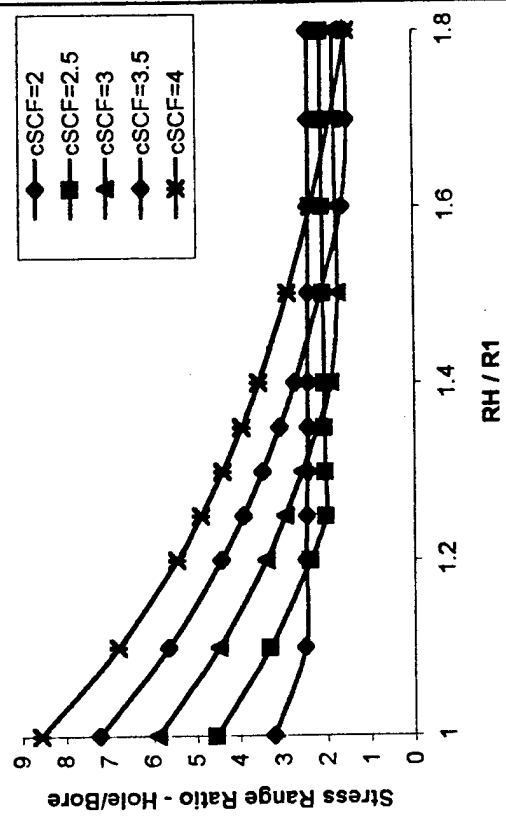

60% Autofrettage, $R2/R1 = 1.8$, $pf/Y=0.4$

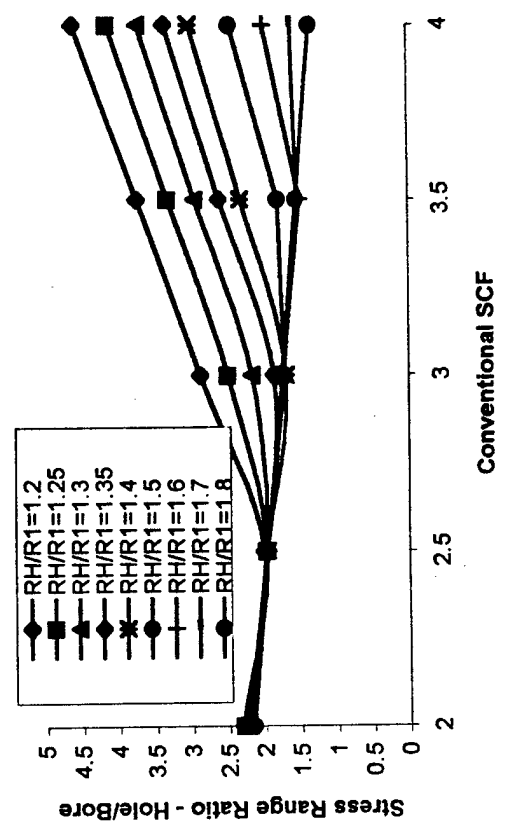

70% Autofrettage, $R2/R1 = 1.8$, $pf/Y=0.4$

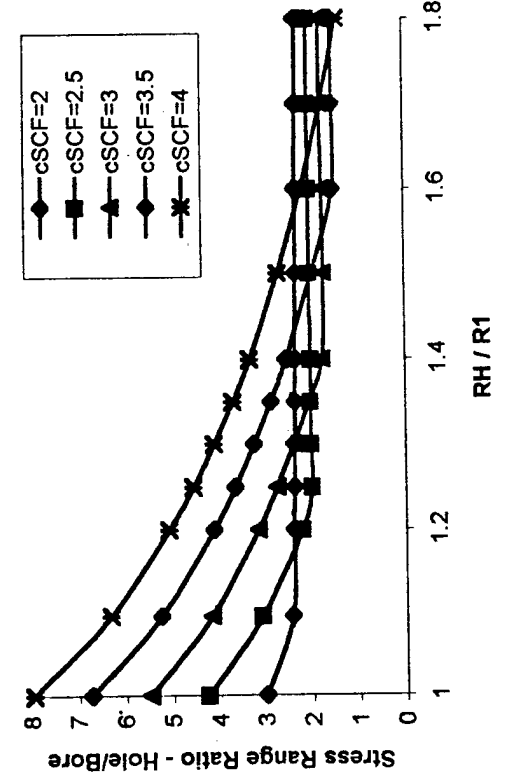

60% Autofrettage, $R2/R1 = 1.8$, $pf/Y=0.4$

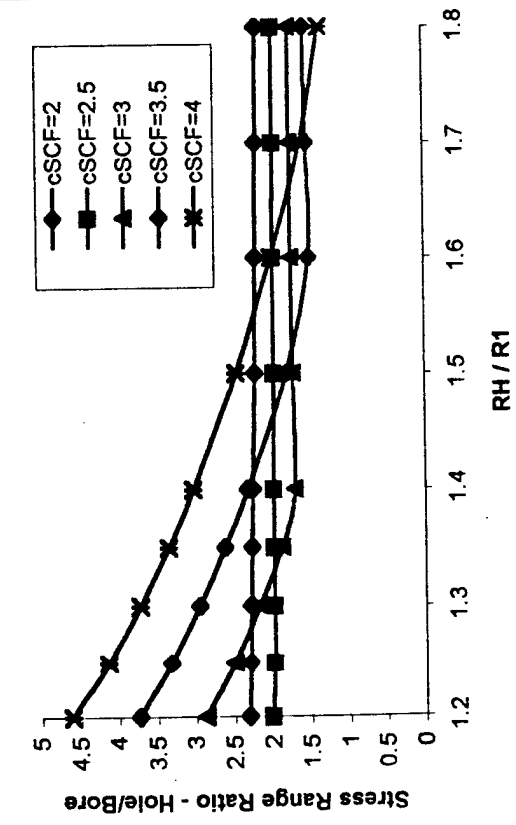

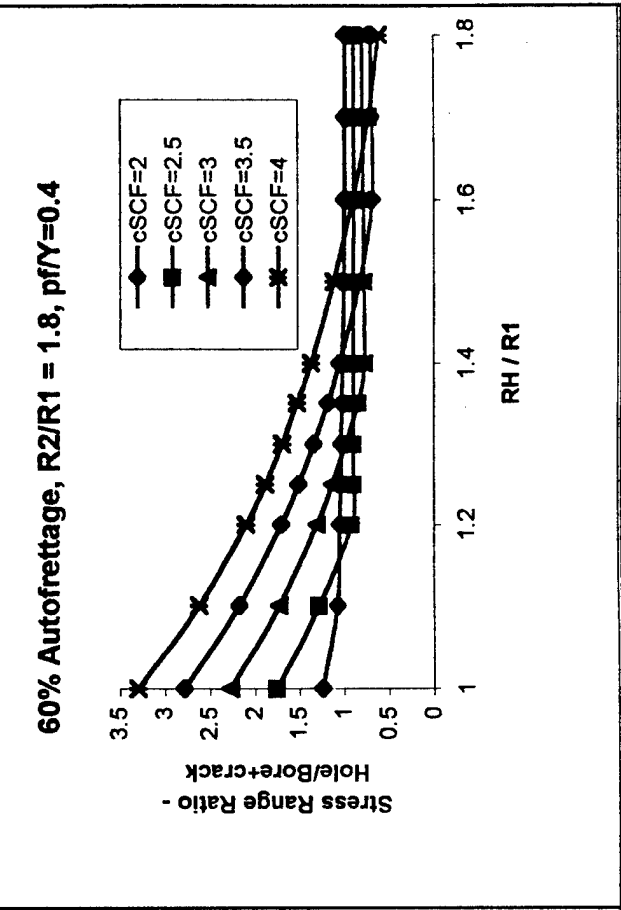
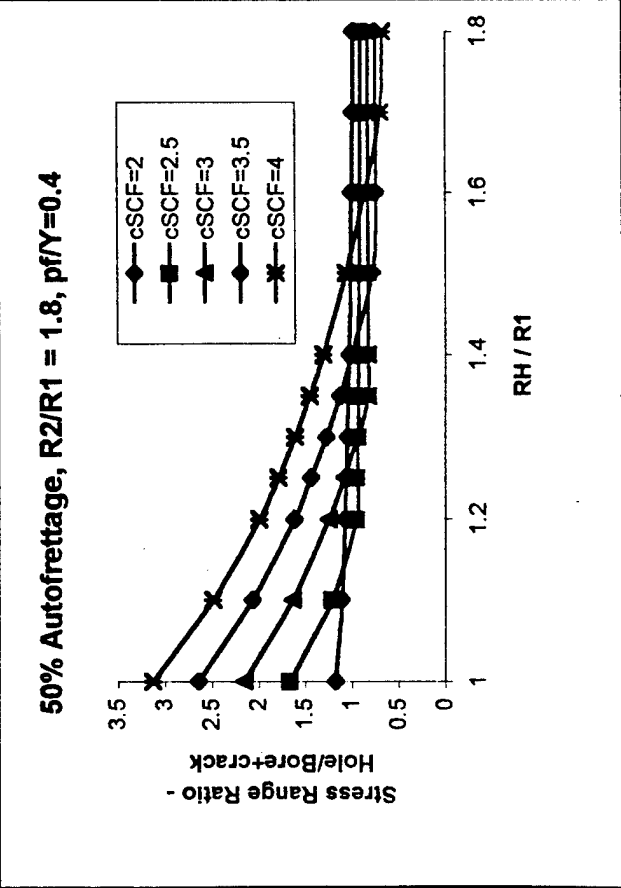
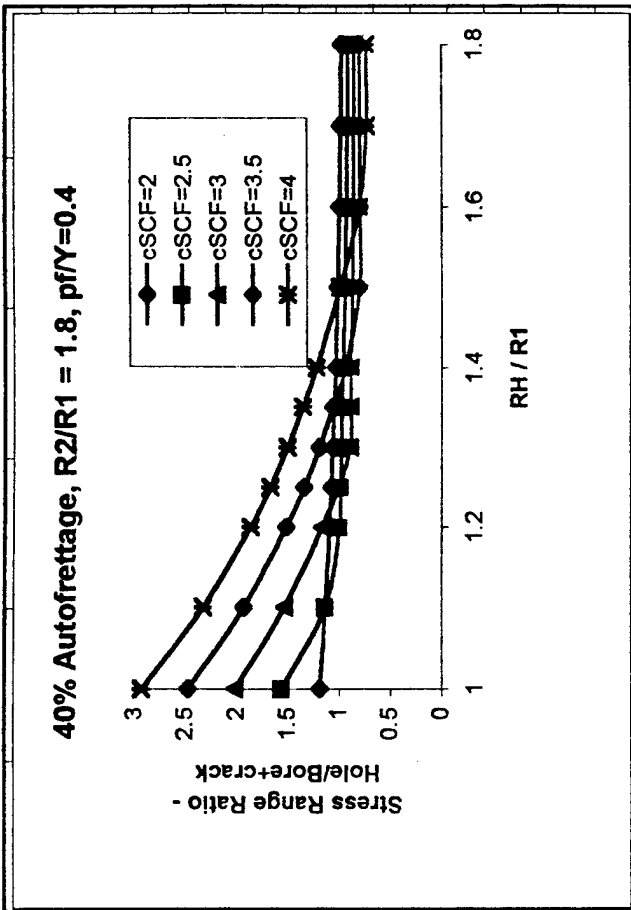
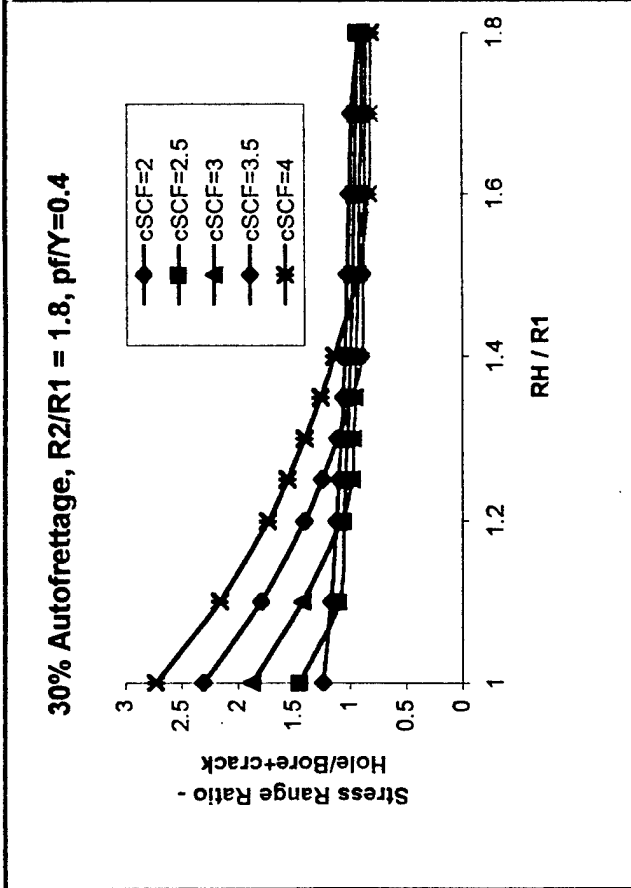

70% Autofrettage, R2/R1 = 1.8, pf/Y=0.4

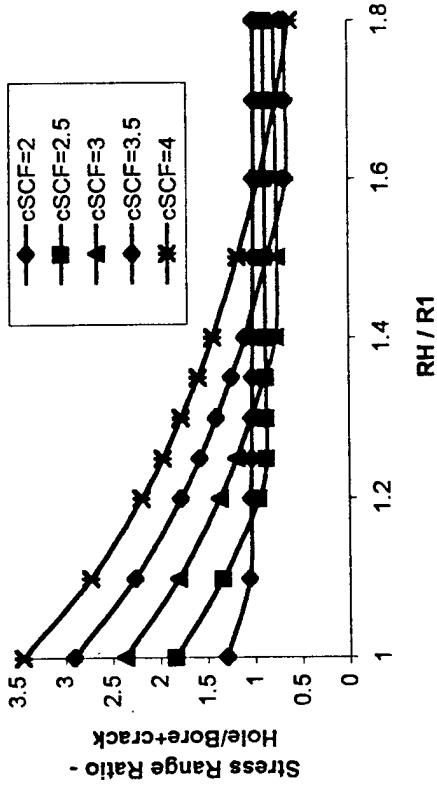

80% Autofrettage, R2/R1 = 1.8, pf/Y=0.4

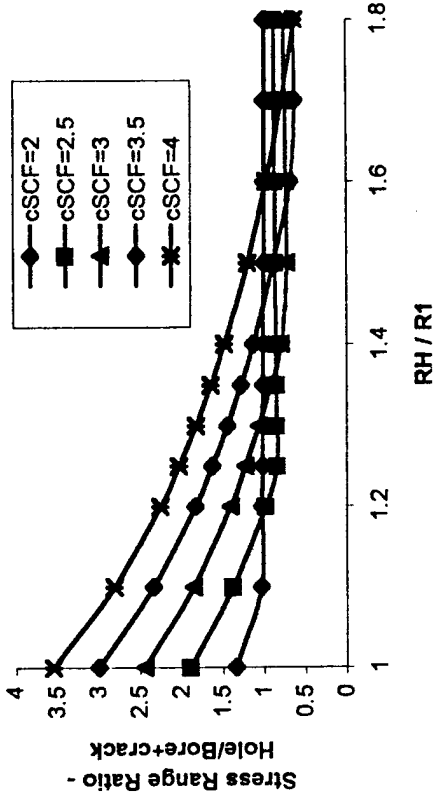

60% Autofrettage, R2/R1 = 1.8, pf/Y=0.4

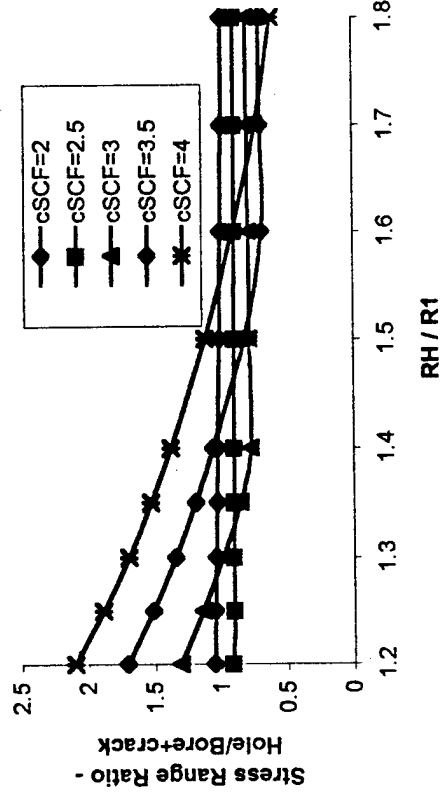

60% Autofrettage, R2/R1 = 1.8, pf/Y=0.4

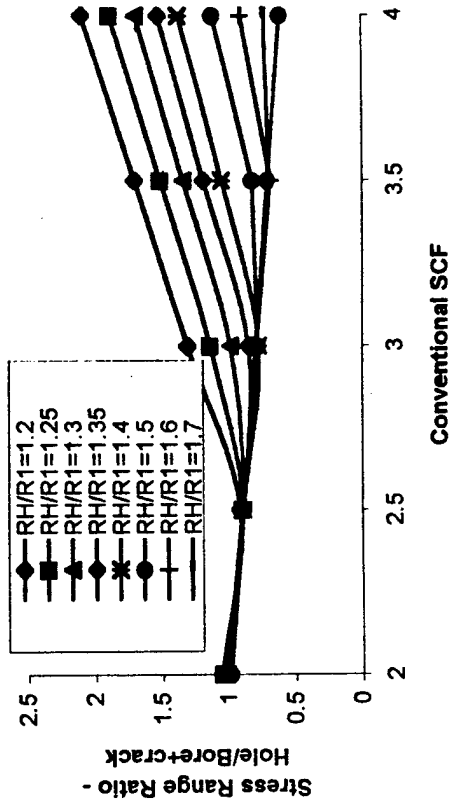

30% Autofrettage, R2/R1 = 1.8, pf/Y=0.333

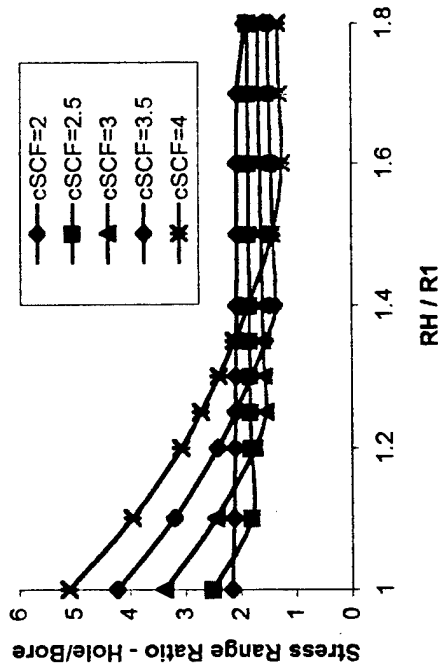

40% Autofrettage, R2/R1 = 1.8, pf/Y=0.333

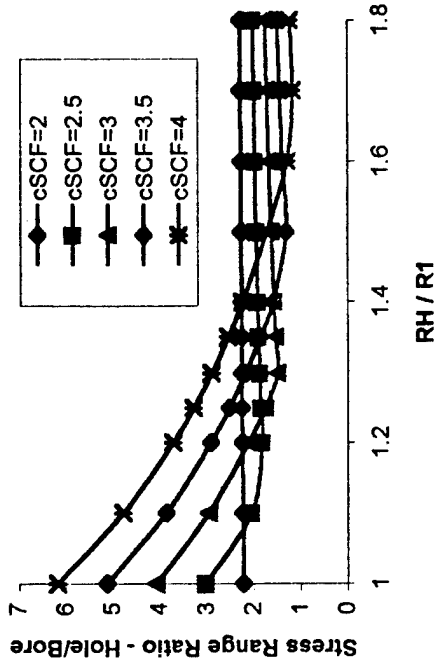

50% Autofrettage, R2/R1 = 1.8, pf/Y=0.333

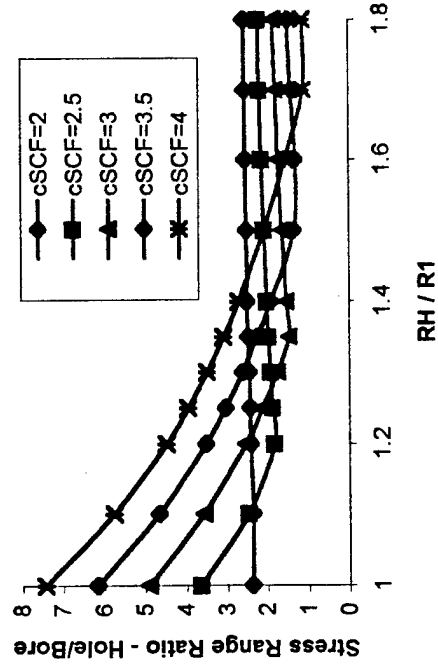

60% Autofrettage, R2/R1 = 1.8, pf/Y=0.333

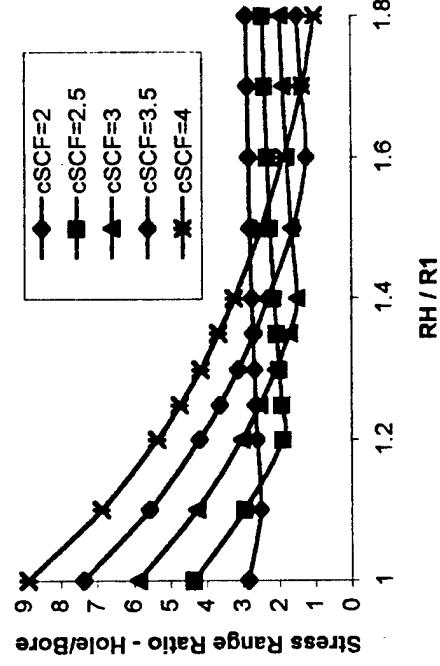

70% Autofrettage, $R2/R1 = 1.8$, $pf/Y = 0.333$

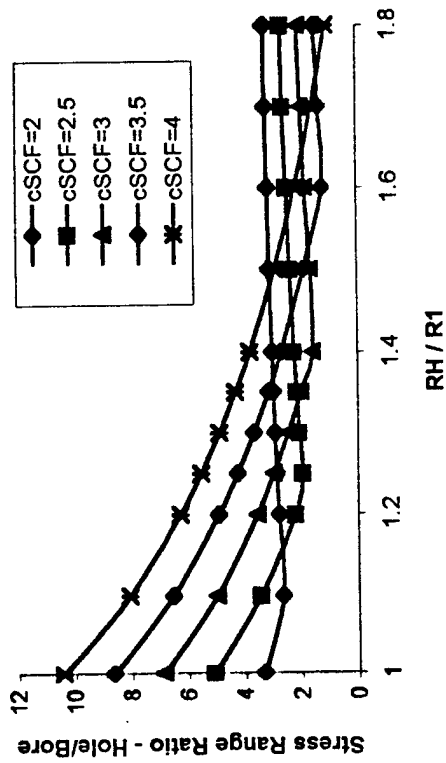

80% Autofrettage, $R2/R1 = 1.8$, $pf/Y = 0.333$

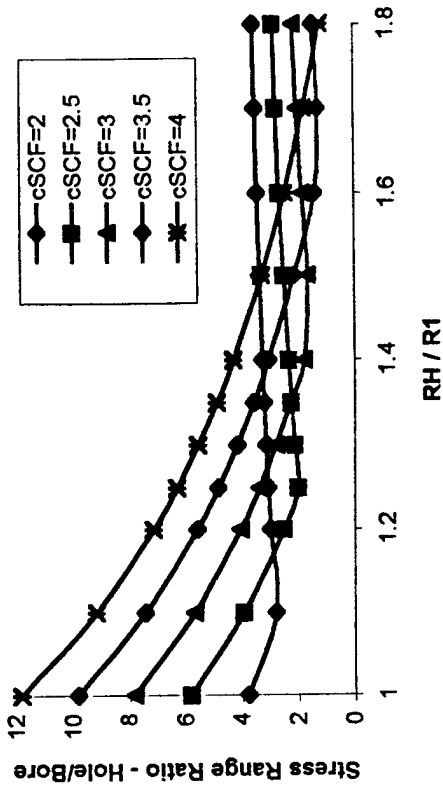

60% Autofrettage, $R2/R1 = 1.8$, $pf/Y = 0.333$

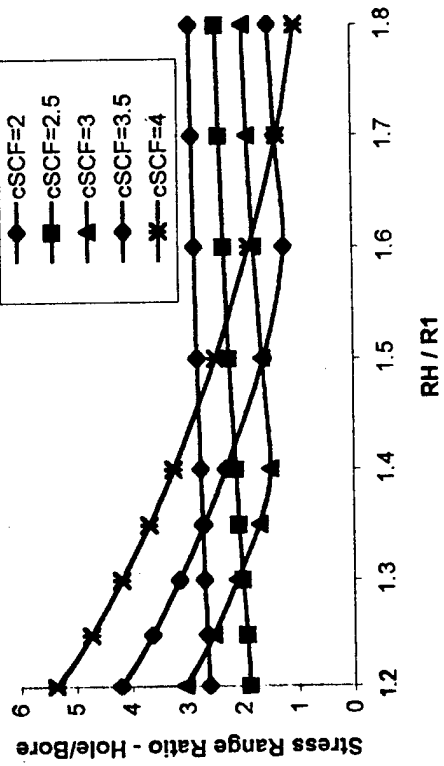

60% Autofrettage, $R2/R1 = 1.8$, $pf/Y = 0.333$

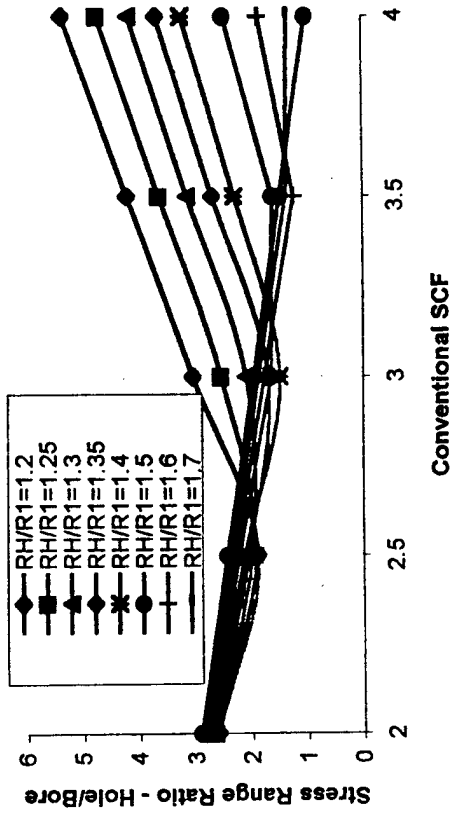

30% Autofrettage, R2/R1 = 1.8, pf/Y=0.333

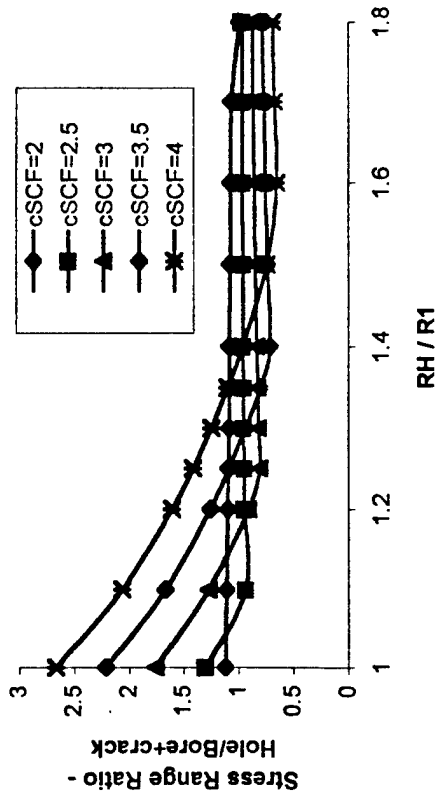

40% Autofrettage, R2/R1 = 1.8, pf/Y=0.333

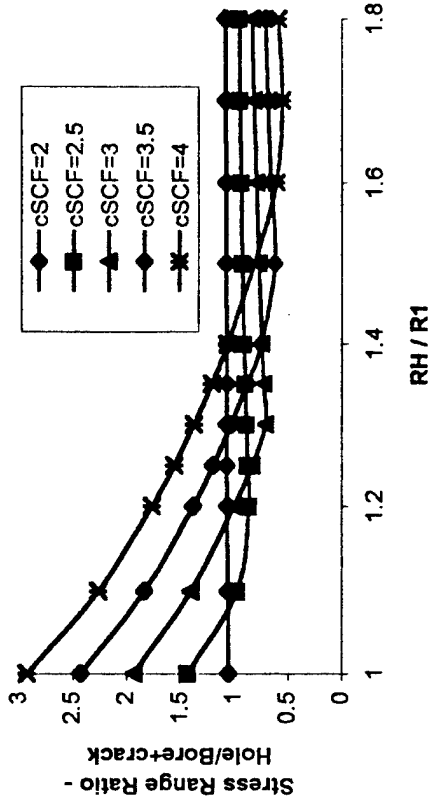

50% Autofrettage, R2/R1 = 1.8, pf/Y=0.333

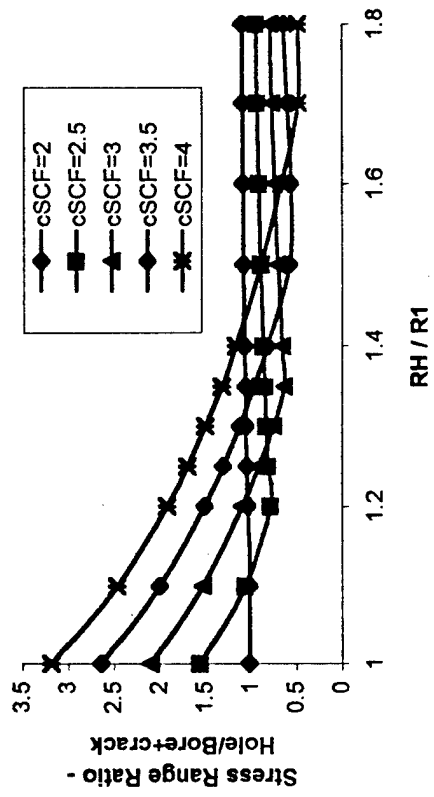

60% Autofrettage, R2/R1 = 1.8, pf/Y=0.333

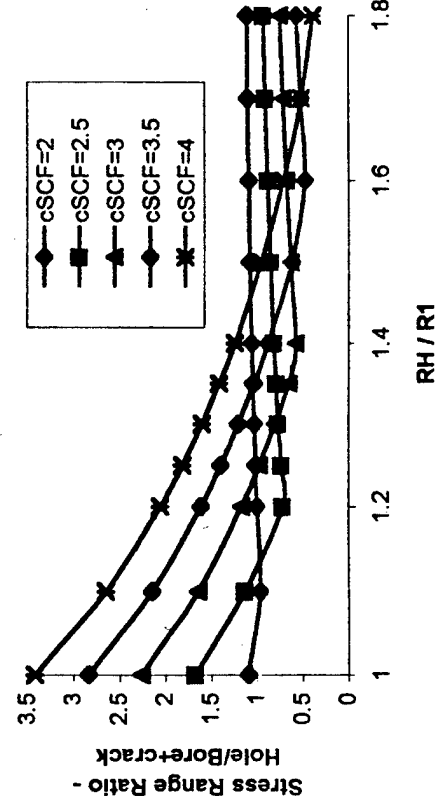

70% Autofrettage, R2/R1 = 1.8, pf/Y=0.333

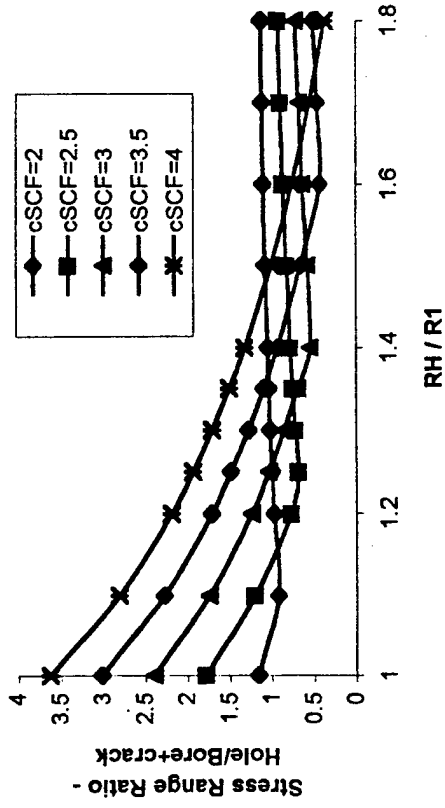

80% Autofrettage, R2/R1 = 1.8, pf/Y=0.333

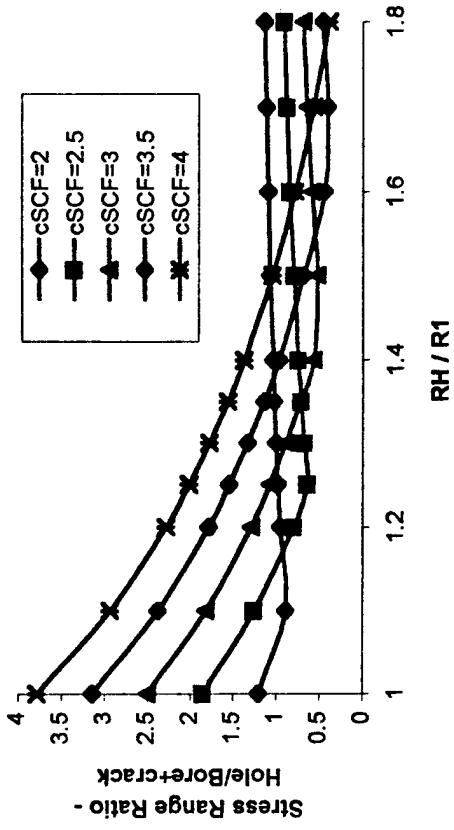

60% Autofrettage, R2/R1 = 1.8, pf/Y=0.333

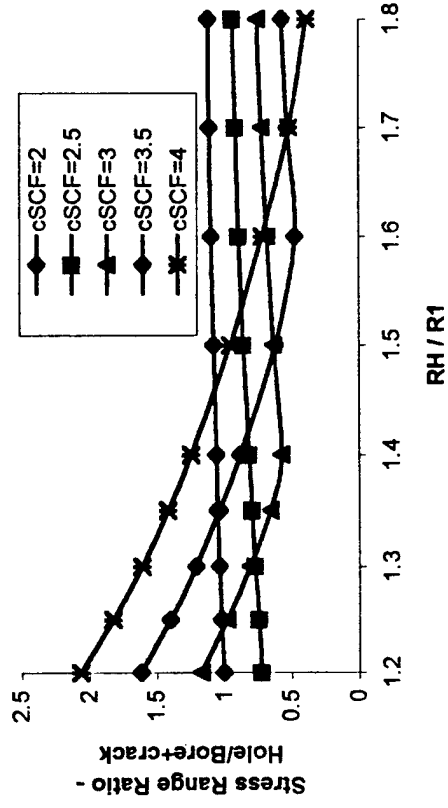

60% Autofrettage, R2/R1 = 1.8, pf/Y=0.333

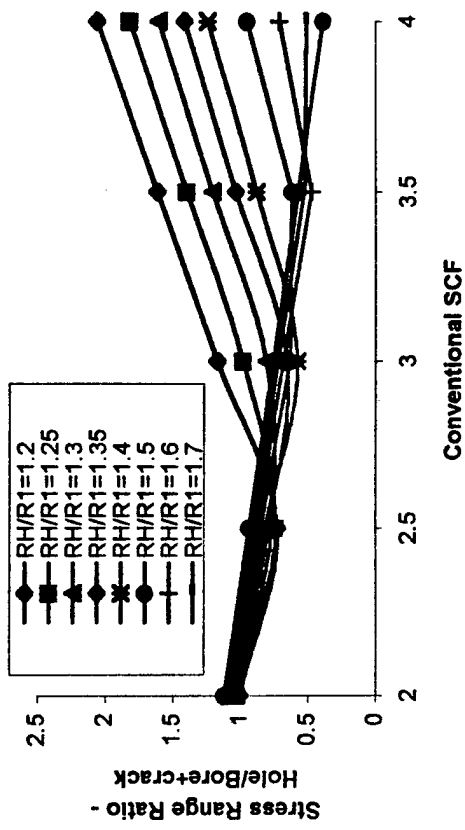

TECHNICAL REPORT INTERNAL DISTRIBUTION LIST

	<u>NO. OF COPIES</u>
CHIEF, DEVELOPMENT ENGINEERING DIVISION	
ATTN: AMSTA-AR-CCB-DA	1
-DB	1
-DC	1
-DD	1
-DE	1
CHIEF, ENGINEERING DIVISION	
ATTN: AMSTA-AR-CCB-E	1
-EA	1
-EB	1
-EC	1
CHIEF, TECHNOLOGY DIVISION	
ATTN: AMSTA-AR-CCB-T	2
-TA	1
-TB	1
-TC	1
TECHNICAL LIBRARY	
ATTN: AMSTA-AR-CCB-O	5
TECHNICAL PUBLICATIONS & EDITING SECTION	
ATTN: AMSTA-AR-CCB-O	3
OPERATIONS DIRECTORATE	
ATTN: SIOVV-ODP-P	1
DIRECTOR, PROCUREMENT & CONTRACTING DIRECTORATE	
ATTN: SIOVV-PP	1
DIRECTOR, PRODUCT ASSURANCE & TEST DIRECTORATE	
ATTN: SIOVV-QA	1

NOTE: PLEASE NOTIFY DIRECTOR, BENÉT LABORATORIES, ATTN: AMSTA-AR-CCB-O OF ADDRESS CHANGES.

TECHNICAL REPORT EXTERNAL DISTRIBUTION LIST

	<u>NO. OF COPIES</u>		<u>NO. OF COPIES</u>
ASST SEC OF THE ARMY RESEARCH AND DEVELOPMENT ATTN: DEPT FOR SCI AND TECH THE PENTAGON WASHINGTON, D.C. 20310-0103	1	COMMANDER ROCK ISLAND ARSENAL ATTN: SMCRI-SEM ROCK ISLAND, IL 61299-5001	1
DEFENSE TECHNICAL INFO CENTER ATTN: DTIC-OCP (ACQUISITIONS) 8725 JOHN J. KINGMAN ROAD STE 0944 FT. BELVOIR, VA 22060-6218	2	MIAC/CINDAS PURDUE UNIVERSITY 2595 YEAGER ROAD WEST LAFAYETTE, IN 47906-1398	1
COMMANDER U.S. ARMY ARDEC ATTN: AMSTA-AR-AEE, BLDG. 3022	1	COMMANDER U.S. ARMY TANK-AUTMV R&D COMMAND ATTN: AMSTA-DDL (TECH LIBRARY) WARREN, MI 48397-5000	1
AMSTA-AR-AES, BLDG. 321	1	COMMANDER	
AMSTA-AR-AET-O, BLDG. 183	1	U.S. MILITARY ACADEMY	
AMSTA-AR-FSA, BLDG. 354	1	ATTN: DEPARTMENT OF MECHANICS	1
AMSTA-AR-FSM-E	1	WEST POINT, NY 10966-1792	
AMSTA-AR-FSS-D, BLDG. 94	1	U.S. ARMY MISSILE COMMAND	
AMSTA-AR-IMC, BLDG. 59	2	REDSTONE SCIENTIFIC INFO CENTER	2
PICATINNY ARSENAL, NJ 07806-5000		ATTN: AMSMI-RD-CS-R/DOCUMENTS BLDG. 4484	
DIRECTOR U.S. ARMY RESEARCH LABORATORY ATTN: AMSRL-DD-T, BLDG. 305	1	REDSTONE ARSENAL, AL 35898-5241	
ABERDEEN PROVING GROUND, MD 21005-5066		COMMANDER	
DIRECTOR U.S. ARMY RESEARCH LABORATORY ATTN: AMSRL-WT-PD (DR. B. BURNS)	1	U.S. ARMY FOREIGN SCI & TECH CENTER ATTN: DRXST-SD	1
ABERDEEN PROVING GROUND, MD 21005-5066		220 7TH STREET, N.E. CHARLOTTESVILLE, VA 22901	
DIRECTOR U.S. MATERIEL SYSTEMS ANALYSIS ACTV ATTN: AMXSY-MP	1	COMMANDER	
ABERDEEN PROVING GROUND, MD 21005-5071		U.S. ARMY LABCOM, ISA ATTN: SLCIS-IM-TL	1
		2800 POWER MILL ROAD ADELPHI, MD 20783-1145	

NOTE: PLEASE NOTIFY COMMANDER, ARMAMENT RESEARCH, DEVELOPMENT, AND ENGINEERING CENTER,
BENÉT LABORATORIES, CCAC, U.S. ARMY TANK-AUTOMOTIVE AND ARMAMENTS COMMAND,
AMSTA-AR-CCB-O, WATERVLIET, NY 12189-4050 OF ADDRESS CHANGES.

TECHNICAL REPORT EXTERNAL DISTRIBUTION LIST (CONT'D)

	<u>NO. OF COPIES</u>		<u>NO. OF COPIES</u>
COMMANDER U.S. ARMY RESEARCH OFFICE ATTN: CHIEF, IPO P.O. BOX 12211 RESEARCH TRIANGLE PARK, NC 27709-2211	1	WRIGHT LABORATORY ARMAMENT DIRECTORATE ATTN: WL/MNM EGLIN AFB, FL 32542-6810	1
DIRECTOR U.S. NAVAL RESEARCH LABORATORY ATTN: MATERIALS SCI & TECH DIV WASHINGTON, D.C. 20375	1	WRIGHT LABORATORY ARMAMENT DIRECTORATE ATTN: WL/MNMF EGLIN AFB, FL 32542-6810	1

NOTE: PLEASE NOTIFY COMMANDER, ARMAMENT RESEARCH, DEVELOPMENT, AND ENGINEERING CENTER,
 BENÉT LABORATORIES, CCAC, U.S. ARMY TANK-AUTOMOTIVE AND ARMAMENTS COMMAND,
 AMSTA-AR-CCB-O, WATERVLIET, NY 12189-4050 OF ADDRESS CHANGES.
