

NCS TIB 96-2

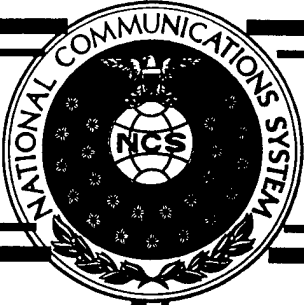

NATIONAL COMMUNICATIONS SYSTEM

TECHNICAL INFORMATION BULLETIN 96-2

SCANNED IMAGES

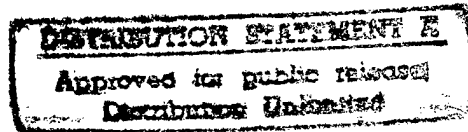

JANUARY 1996

19970117 155

OFFICE OF THE MANAGER
NATIONAL COMMUNICATIONS SYSTEM
701 SOUTH COURT HOUSE ROAD
ARLINGTON, VA 22204-2198

DTC QUALITY INSPECTED 1

DISCLAIMER NOTICE

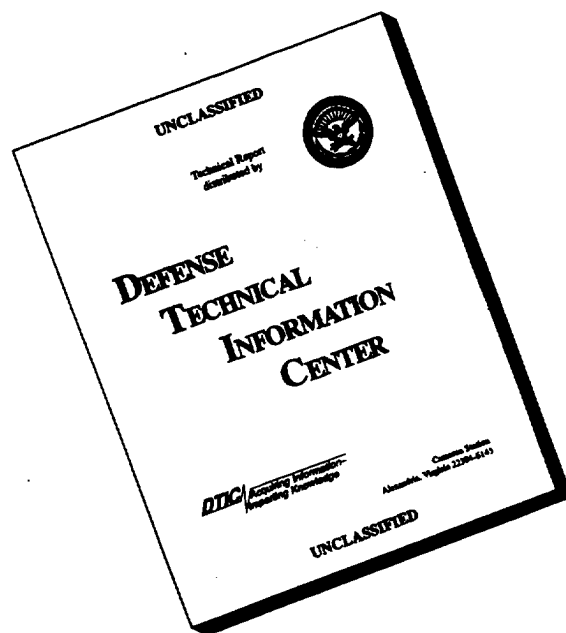

THIS DOCUMENT IS BEST QUALITY AVAILABLE. THE COPY FURNISHED TO DTIC CONTAINED A SIGNIFICANT NUMBER OF PAGES WHICH DO NOT REPRODUCE LEGIBLY.

REPORT DOCUMENTATION PAGE

Form Approved
OMB No. 0704-0188

Public reporting burden for this collection of information is estimated to average 1 hour per response, including the time for reviewing instructions, searching existing data sources, gathering and maintaining the data needed, and completing and reviewing the collection of information. Send comments regarding this burden estimate or any other aspect of this collection of information, including suggestions for reducing this burden, to Washington Headquarters Services, Directorate for Information Operations and Reports, 1215 Jefferson Davis Highway, Suite 1204, Arlington, VA 22202-4302, and to the Office of Management and Budget, Paperwork Reduction Project (0704-0188), Washington, DC 20503.

1. AGENCY USE ONLY (Leave blank)	2. REPORT DATE January 1996	3. REPORT TYPE AND DATES COVERED Final Report
----------------------------------	--------------------------------	--

4. TITLE AND SUBTITLE Scanned Images	5. FUNDING NUMBERS DCA100-91-C-0031
---	--

6. AUTHOR(S) Stephen Perschau	
--------------------------------------	--

7. PERFORMING ORGANIZATION NAME(S) AND ADDRESS(ES) Delta Information System, Inc. 300 Welsh Road, Bldg 3, Suite 120 Horsham, PA 19044-2273	8. PERFORMING ORGANIZATION REPORT NUMBER
---	--

9. SPONSORING/MONITORING AGENCY NAME(S) AND ADDRESS(ES) National Communications System Office of Technology and Standards Division 701 South Court House Road Arlington, Virginia 22204-2198	10. SPONSORING/MONITORING AGENCY REPORT NUMBER NCS TIB 96-2
--	--

11. SUPPLEMENTARY NOTES This report supersedes NCS TIB #95-3.
--

12a. DISTRIBUTION/AVAILABILITY STATEMENT Approved for public release; distribution is unlimited.	12b. DISTRIBUTION CODE
---	------------------------

13. ABSTRACT (Maximum 200 words) The purpose of this project was to continue the work that began in the previous year toward the achievement of an ITU-T test image recommendation. As a result of comments and suggestions to the imagery contained on the first test CD-ROM titled "Standard Image Set, Beta Test CD-01", a second test CD-ROM was crated for the ITU-T. This rport describe this new test CD-ROM and the images contained on it; provides the standards groups who received evaluation copies of the test CD-ROM; contains a description of the images contained in the "JPEG Continuation-tone Test Image Set". This set of images was used in the performance evaluation of nine different proposed JPEG compression algorithms. The performance results obtained using the different JPEG algorithms on these images is given in this report. It also gives recommendations for further work in this area. The NCS has been a leader in the development and promulgation of standardized imagery for facsimile. The NCS has sponsored the digitization of documents at resolutions of 200, 240, 300, 400, 480, 600, and 800 lines per inch. This data has been used extensively in the study of standard compression of facsimile recommendations. These recommendations are of considerable value to the US Government.

14. SUBJECT TERMS Facsimile Color Image	15. NUMBER OF PAGES 50
	16. PRICE CODE

17. SECURITY CLASSIFICATION OF REPORT UNCLASS	18. SECURITY CLASSIFICATION OF THIS PAGE UNCLASS	19. SECURITY CLASSIFICATION OF ABSTRACT UNCLASS	20. LIMITATION OF ABSTRACT UNLIMITED
--	---	--	---

GENERAL INSTRUCTIONS FOR COMPLETING SF 298

The Report Documentation Page (RDP) is used in announcing and cataloging reports. It is important that this information be consistent with the rest of the report, particularly the cover and title page. Instructions for filling in each block of the form follow. It is important to *stay within the lines* to meet *optical scanning requirements*.

Block 1. Agency Use Only (Leave blank).

Block 2. Report Date. Full publication date including day, month, and year, if available (e.g. 1 Jan 88). Must cite at least the year.

Block 3. Type of Report and Dates Covered. State whether report is interim, final, etc. If applicable, enter inclusive report dates (e.g. 10 Jun 87 - 30 Jun 88).

Block 4. Title and Subtitle. A title is taken from the part of the report that provides the most meaningful and complete information. When a report is prepared in more than one volume, repeat the primary title, add volume number, and include subtitle for the specific volume. On classified documents enter the title classification in parentheses.

Block 5. Funding Numbers. To include contract and grant numbers; may include program element number(s), project number(s), task number(s), and work unit number(s). Use the following labels:

C - Contract	PR - Project
G - Grant	TA - Task
PE - Program Element	WU - Work Unit Accession No.

Block 6. Author(s). Name(s) of person(s) responsible for writing the report, performing the research, or credited with the content of the report. If editor or compiler, this should follow the name(s).

Block 7. Performing Organization Name(s) and Address(es). Self-explanatory.

Block 8. Performing Organization Report Number. Enter the unique alphanumeric report number(s) assigned by the organization performing the report.

Block 9. Sponsoring/Monitoring Agency Name(s) and Address(es). Self-explanatory.

Block 10. Sponsoring/Monitoring Agency Report Number. (If known)

Block 11. Supplementary Notes. Enter information not included elsewhere such as: Prepared in cooperation with...; Trans. of...; To be published in.... When a report is revised, include a statement whether the new report supersedes or supplements the older report.

Block 12a. Distribution/Availability Statement. Denotes public availability or limitations. Cite any availability to the public. Enter additional limitations or special markings in all capitals (e.g. NOFORN, REL, ITAR).

DOD - See DoDD 5230.24, "Distribution Statements on Technical Documents."

DOE - See authorities.

NASA - See Handbook NHB 2200.2.

NTIS - Leave blank.

Block 12b. Distribution Code.

DOD - Leave blank.

DOE - Enter DOE distribution categories from the Standard Distribution for Unclassified Scientific and Technical Reports.

NASA - Leave blank.

NTIS - Leave blank.

Block 13. Abstract. Include a brief (*Maximum 200 words*) factual summary of the most significant information contained in the report.

Block 14. Subject Terms. Keywords or phrases identifying major subjects in the report.

Block 15. Number of Pages. Enter the total number of pages.

Block 16. Price Code. Enter appropriate price code (*NTIS only*).

Blocks 17. - 19. Security Classifications. Self-explanatory. Enter U.S. Security Classification in accordance with U.S. Security Regulations (i.e., UNCLASSIFIED). If form contains classified information, stamp classification on the top and bottom of the page.

Block 20. Limitation of Abstract. This block must be completed to assign a limitation to the abstract. Enter either UL (unlimited) or SAR (same as report). An entry in this block is necessary if the abstract is to be limited. If blank, the abstract is assumed to be unlimited.

NCS TECHNICAL INFORMATION BULLETIN 96-2

SCANNED IMAGES

JANUARY 1996

PROJECT OFFICER

APPROVED FOR PUBLICATION:



STEPHEN PERSCHAU
Computer Scientist
Technology and
Standards Division



DENNIS BODSON
Chief
Technology and
Standards Division

FOREWORD

Among the responsibilities assigned to the Office of the Manager, National Communications System, is the management of the Federal Telecommunication Standards Program. Under this program, the NCS, with the assistance of the Federal Telecommunication Standards Committee identifies, develops, and coordinates proposed Federal Standards which either contribute to the interoperability of functionally similar Federal telecommunication systems or to the achievement of a compatible and efficient interface between computer and telecommunication systems. In developing and coordinating these standards, a considerable amount of effort is expended in initiating and pursuing joint standards development efforts with appropriate technical committees of the International Organization for Standardization, and the International Telegraph and Telephone Consultative Committee of the International Telecommunication Union. This Technical Information Bulletin presents an overview of an effort which is contributing to the development of compatible Federal, national, and international standards in the area of facsimile. It has been prepared to inform interested Federal activities of the progress of these efforts. Any comments, inputs or statements of requirements which could assist in the advancement of this work are welcome and should be addressed to:

Office of the Manager
National Communications System
Attn: N6
701 S. Court House Road
Arlington, VA 22204-2198

TASK 1
TECHNICAL WORK IN THE AREA
OF FACSIMILE

SUBTASK 4
SCANNED IMAGES

FINAL REPORT
CONTRACT DCA100-91-C-0031
OPTION YEAR 4

Submitted to:
NATIONAL COMMUNICATIONS SYSTEM
ARLINGTON, VA

January, 1996

DELTA INFORMATION SYSTEMS, INC.
300 Welsh Road, Bldg. 3, Ste. 120
Horsham, PA 19044-2273
TEL: (215) 657-5270 FAX: (215) 657-5273

TABLE OF CONTENTS

TABLE OF CONTENTS	i
1 Introduction	1
2 Standard Image Set (Beta Test CD-02)	1
2.1 Bi-level Images	2
2.1.1 ITU-T Reference Documents	3
2.1.2 Black/White Facsimile Test Chart BW01	4
2.1.3 Half-Tone Images	4
2.1.3.1 Dithered Images	4
2.2 Gray Scale Images	4
2.2.1 T.22 test Chart No. 5	5
2.2.2 House with Trees and House with Sky	5
2.3 Color Images	5
2.3.1 CIELAB Color Space	6
2.3.2 RGB Color Space	7
2.3.3 Scanned Color Chart	7
2.3.4 Computer-generated Color Chart	8
2.3.5 Kids with Toys	8
2.3.6 Computer-Generated Spheres	8
2.3.7 Graphics-Art	9
3 Test CD-02 Image Storage	9
4 Test CD-02 Architecture and Duplication	9
5 Test CD-02 Distribution	10
6 JPEG Continuous-Tone Test Images	11
6.1 CD-ROM Contents	11
6.2 JPEG Compression Evaluation Using Test Images	13
7 Recommendations	18
Appendix A - ITU-T Approved Image Set	
Appendix B - Advanced Lossless JPEG Images	
Appendix C - Evaluation Criteria for JPEG Compression Algorithms	

1 Introduction

This document summarizes work performed by Delta Information Systems, Inc. (DIS) for the National Communications System (NCS), Office of Technology and Standards. This office is responsible for the management of the Federal Telecommunications Standards Program, which develops telecommunications standards. The use of these standards is mandatory for all Federal departments and agencies.

The NCS has been a leader in the development and promulgation of standardized imagery for facsimile. The NCS has sponsored the digitization of documents at resolutions of 200, 240, 300, 400, 480, 600, and 800 lines per inch. This data has been used extensively in the study of standard compression algorithms for digital facsimile, and has contributed significantly to the development of facsimile recommendations. These recommendations are of considerable value to the United States Government. In addition to this work, the NCS sponsored the preparation of gray scale and color images that are representative of continuous tone pictures and computer generated images to be transmitted through facsimile systems.

The purpose of this project was to continue the work that began in the previous year toward the achievement of an ITU-T test image recommendation. As a result of comments and suggestions to the imagery contained on the first test CD-ROM titled "Standard Image Set, Beta Test CD-01", a second test CD-ROM was created for the ITU-T. Sections 2 through 4 of this report describe this new test CD-ROM and the images contained on it. Section 5 provides the standards groups who received evaluation copies of the test CD-ROM. Section 6 contains a description of the images contained in the "JPEG Continuous-tone Test Image Set". This set of images was used in the performance evaluation of nine different proposed JPEG compression algorithms. In addition, the performance results obtained using the different JPEG algorithms on these images is given in this section. Section 7 gives recommendations for further work in this area.

2 Standard Image Set (Beta Test CD-02)

The title of the new test CD-ROM is "Standard Image Set (Beta Test CD-02)". This test CD-ROM will also be referenced in this report as Test CD-02. The test suite of images described in this report are comprised of the set of images as specified in ITU-T Recommendation T.24. Test CD-02 represents the current state of the ITU-T test image recommendation and contains all of the images described in this report. There are three different classes of images stored on the test CD-ROM. These three classes are bi-level or 1 bit/pixel, gray scale with 8-bits/pixel, and color with 24-bits/pixel. Since all of the images are stored on the test CD-ROM as TIFF files, they can be viewed with any available viewer complying with the TIFF specification. See Appendix A for

illustrations of the images contained on Test CD-02. For each class of images, a brief description and a table of image parameters is given in the following three sections. For additional information, see the Technical Information Bulletin 93-15 (TIB), "Scanned Images", National Communications System, December, 1993.

2.1 Bi-level Images

The bi-level images are quantized using 1-bit per sample or pixel. All of the bi-level images are stored as TIFF files and are compressed using ITU-T Recommendation T.6 compression. Table 1 provides the specifications for the bi-level images included in the image set on Test CD-02.

TABLE 1 Bi-level Image Set

Bi-level Image Set								
Filename	Figure number	Image Name	Description	Color Space	Bits per comp.	Image Dimensions Pixels (W x H)	Resolution (Pixels/Inch)	File Size (Bytes)
F01_200	1	ITU-T Document No. 1	English Letter	Bi-level	1	1728 x 2339	200	32,613
F01_300	1	" "	" "	Bi-level	1	2592 x 3508	300	58,368
F01_400	1	" "	" "	Bi-level	1	3456 x 4677	400	92,460
F01_600	1	" "	" "	Bi-level	1	5184 x 7016	600	181,470
F02_200	2	ITU-T Document No. 2	Circuit Drawing	Bi-level	1	1728 x 2339	200	32,092
F02_300	2	" "	" "	Bi-level	1	2592 x 3508	300	55,001
F02_400	2	" "	" "	Bi-level	1	3456 x 4677	400	83,833
F02_600	2	" "	" "	Bi-level	1	5184 x 7016	600	147,882
F03_200	3	ITU-T Document No. 3	French Invoice	Bi-level	1	1728 x 2339	200	57,161
F03_300	3	" "	" "	Bi-level	1	2592 x 3508	300	101,549
F03_400	3	" "	" "	Bi-level	1	3456 x 4677	400	155,603
F03_600	3	" "	" "	Bi-level	1	5184 x 7016	600	287,596
F04_200	4	ITU-T Document No. 4	French Text	Bi-level	1	1728 x 2339	200	94,974
F04_300	4	" "	" "	Bi-level	1	2592 x 3508	300	175,273
F04_400	4	" "	" "	Bi-level	1	3456 x 4677	400	278,152
F04_600	4	" "	" "	Bi-level	1	5184 x 7016	600	536,250
F05_200	5	ITU-T Document No. 5	French Text Figures	Bi-level	1	1728 x 2339	200	59,712
F05_300	5	" "	" "	Bi-level	1	2592 x 3508	300	106,388
F05_400	5	" "	" "	Bi-level	1	3456 x 4677	400	165,997
F05_600	5	" "	" "	Bi-level	1	5184 x 7016	600	304,338

Bi-level Image Set								
Filename	Figure number	Image Name	Description	Color Space	Bits per comp.	Image Dimensions Pixels (W x H)	Resolution (Pixels/Inch)	File Size (Bytes)
F06_200	6	ITU-T Document No. 6	French Chart	Bi-level	1	1728 x 2339	200	47,877
F06_300	6	" "	" "	Bi-level	1	2592 x 3508	300	80,729
F06_400	6	" "	" "	Bi-level	1	3456 x 4677	400	124,469
F06_600	6	" "	" "	Bi-level	1	5184 x 7016	600	223,105
F07_200	7	ITU-T Document No. 7	Kanji	Bi-level	1	1728 x 2339	200	101,882
F07_300	7	" "	" "	Bi-level	1	2592 x 3508	300	177,144
F07_400	7	" "	" "	Bi-level	1	3456 x 4677	400	272,005
F07_600	7	" "	" "	Bi-level	1	5184 x 7016	600	218,952
F08_200	8	ITU-T Document No. 8	Handwritten Memorandum	Bi-level	1	1728 x 2339	200	60,221
F08_300	8	" "	" "	Bi-level	1	2592 x 3508	300	104,319
F08_400	8	" "	" "	Bi-level	1	3456 x 4677	400	161,804
F08_600	8	" "	" "	Bi-level	1	5184 x 7016	600	270,070
F09_400	9	T.22 Test Chart No. 4	Facsimile Test Chart	Bi-level	1	3504 x 4750	400	399,561
F10_200	10	Half-tone Chart	Text for legibility testing, half-tones	Bi-level	1	1728 x 2336	200	150,078
F10_240	10	" "	" "	Bi-level	1	2048 x 2800	240	271,285
F10_300	10	" "	" "	Bi-level	1	2560 x 3500	300	393,607
F11_400	11	Sailboat #1	8x8 dithering	Bi-level	1	3072 x 2048	400	942,716
F12_400	12	Sailboat #2	Error diffusion	Bi-level	1	3072 x 2048	400	736,317
F13_400	13	Sailboat #3	4x4 dithering	Bi-level	1	3072 x 2048	400	1,145,619
F14_400	14	Sailboat #4	3x3 dithering	Bi-level	1	3072 x 2048	400	969,973
F15_200	15	Composite	Dithered composite	Bi-level	1	1904 x 1488	200	334,141
F16_800	16	Magazine Text, Half-tone	Screened half-tone and inverted text	Bi-level	1	3456 x 4416	800	406,855
F17_400	17	Magazine Page, Composite	Contains half-tone, text and inverted text	Bi-level	1	3072 x 4352	400	832,344
TOTAL IMAGE STORAGE SPACE REQUIREMENTS								11,431,785

2.1.1 ITU-T Reference Documents

Figures 1 through 8 illustrate the 8 standard ITU-T Reference documents. These documents have been used extensively by experimenters over the years. Each

document is provided at 4 different resolutions of 200, 300, 400, and 600 pixels per inch with 1 bit per pixel.

2.1.2 Black/White Facsimile Test Chart BW01

This bi-level image shown in Figure 9 is the first of two charts that make up T.22 and is called T.22 Test Chart No. 4. The image is the digitization of the high contrast black and white chart which contains text in a variety of languages, fonts and pitches, and various test patterns.

2.1.3 Half-Tone Images

Figures 10 through 17 illustrate bi-level half tone images. Figure 10 is the image containing random text in four different fonts with six different point sizes. The lower half contains half-tone imagery at five different screen densities. Figure 16 is a combination of a screened half tone image and an electronically scanned text that has been inverted. Both the text and image components of the figure were extracted from a magazine. Figure 17 is a composite of electronically scanned segments of magazine pages. It includes a half-tone, text, and inverted text.

2.1.3.1 Dithered Images

Four different processing algorithms were applied to a gray scale sailboat image to produce the sailboat Figures 11 through 14. The processing included 8x8 dithering, error diffusion, 4x4 dithering, and 3x3 dithering for figures 11 through 14 respectively. Figure 15 is the house with sky image processed with dither patterns of 4x4, random dithering, ordered 8x8, and clump dithering in clockwise order starting from the upper left corner.

2.2 Gray Scale Images

Table 2 provides the specifications for the gray scale images included in the image set on Test CD-02. The gray scale images are stored uncompressed in the TIFF file format with the Photometric Interpretation Tag set to 1 and the bits per sample set to 8.

TABLE 2 Gray scale Image Set

Gray scale Image Set								
Filename	Figure number	Image Name	Description	Color Space	Bits per comp.	Image Dimensions Pixels (W x H)	Resolution (Pixels/Inch)	File Size (Bytes)
F18_200	18	T.22 Test Chart No. 5	Continuous tone test chart CT01	Gray scale	8	1700 x 2184	200	3,713,248
F18_400	18	" "	" "	Gray scale	8	3380 x 4367	400	14,760,908
F19_200	19	House With Trees	Photo of a house surrounded by trees	Gray scale	8	940 x 820	200	774,174
F19_240	19	" "	" "	Gray scale	8	1128 x 984	240	1,114,310
F19_300	19	" "	" "	Gray scale	8	1410 x 1230	300	1,740,954
F19_400	19	" "	" "	Gray scale	8	1880 x 1640	400	3,091,494
F20_200	20	House With Sky	Photo of a house; decorative plantings only	Gray scale	8	940 x 820	200	783,598
F20_240	20	" "	" "	Gray scale	8	1128 x 984	240	1,127,878
F20_300	20	" "	" "	Gray scale	8	1410 x 1230	300	1,762,168
F20_400	20	" "	" "	Gray scale	8	1880 x 1640	400	3,129,174
TOTAL IMAGE STORAGE SPACE REQUIREMENTS								31,997,906

2.2.1 T.22 test Chart No. 5

Figure 18 is the continuous tone gray scale test chart designed specifically for facsimile testing. This image is part two of ITU-T T.22. The file consists of several strips and patches of various gray scale levels and two photographs, an architectural photograph and a portrait. Figure 18 is given at two resolutions, 200 pixels per inch and 400 pixels per inch.

2.2.2 House with Trees and House with Sky

Figures 19 and Figure 20 are the gray scale House with Trees image and House with Sky image respectively. The House With Trees and House With Sky images have been digitized at the resolutions of 200, 240, 300, and 400 pixels per inch.

2.3 Color Images

The color images are stored as Class R uncompressed TIFF 6.0 files. The images are pixel interlaced consisting of L*a*b* triplets with 8-bit precision for each

color component. The resulting images are 24 bit color. The images were also converted (except for the scanned Color Test Chart) and stored as pixel interlaced files consisting of RGB triplets of one-byte precision for the R, G, and B color components. Table 3 provides the specifications for the color images included in the image set on Test CD-02. The Scanned Color Chart and the Computer-generated Color Chart images shown in Figure 21 are derived from ITU-T T.23 test Chart No. 6. The color images shown in Figures 22 through 24 originate from the Color Test Chart.

TABLE 3 Color Image Set

Color Image Set							
Filename	Figure number	Image Name	Color Space	Bits per comp.	Image Dimensions Pixels (W x H)	Resolution (Pixels/Inch)	File Size (Bytes)
F21_200	21	Scanned Color Chart	CIELAB	8	1688 x 2347	200	11,885,412
F21_400	21	" "	CIELAB	8	3399 x 4752	400	48,456,749
F21a200	21	Computer-generated color chart	CIELAB	8	1752 x 2375	200	12,502,266
F21a400	21	" "	CIELAB	8	3504 x 4750	400	49,970,266
F21b400	22	Kids with toys	CIELAB	8	3242 x 3656	400	35,587,708
F21c400	23	Computer-generated Spheres	CIELAB	8	1024 x 512	400	1,577,164
F21d200	24	Graphics-art	CIELAB	8	2644 x 3046	200	24,185,444
F21_200v	21	Scanned Color Chart	RGB	8	1688 x 2347	200	11,885,412
F21_400v	21	" "	RGB	8	3399 x 4752	400	48,456,749
F21a200v	21	Computer-generated color chart	RGB	8	1752 x 2375	200	12,502,266
F21a400v	21	" "	RGB	8	3504 x 4750	400	49,970,266
F21b400v	22	Kids with toys	RGB	8	3242 x 3656	400	35,587,708
F21c400v	23	Computer-generated Spheres	RGB	8	1024 x 512	400	1,577,164
F21d200v	24	Graphics-art	RGB	8	2644 x 3046	200	24,185,444
TOTAL IMAGE STORAGE SPACE REQUIREMENTS							368,330,018

2.3.1 CIELAB Color Space

The color image files are stored with the CIELAB color space. Although the Photometric tag corresponding to the CIELAB color space is defined for the TIFF file format, few TIFF implementations currently use this Photometric tag. An approved standard for an 8-bit fixed point representation of the L*, a*, and b* components of

CIELAB has not been defined. For this reason, the TIFF 6.0 file format used for the color images does not have the Photometric tag set to CIELAB, but rather to RGB. The seven color images supplied on this CD-ROM with the CIELAB color space have the following 8-bit fixed point representation of the L^* , a^* , and b^* components. The L^* component range is 0 to 100 [0,100] and the a^* and b^* component range is -128 to 127 [-128,127]. These files are useful for the comparison of image compression algorithm performance.

2.3.2 RGB Color Space

The color images are also stored in the RGB color space. The color test chart was scanned using an RGB scanner and the RGB values generated by the scanner are contained in the file. For all the other color images, the mapping from the CIELAB color space to the RGB color space was necessary. The L^* , a^* , and b^* components of each color image were converted to monitor RGB values with gamma correction. The color images stored in the RGB color space are included for viewing purposes. The use of these images for the comparison of image compression algorithm performance is not recommended due to the losses inherent in the color space mapping from CIELAB to RGB. The inclusion of color images in the RGB color space was done primarily for viewing purposes.

2.3.3 Scanned Color Chart

The Scanned Color Chart image is derived from ITU-T T.23 test Chart No. 6 at two resolutions. Figure 21 shows the 4-Color Printing Facsimile Test Chart 4CP01 which was scanned on an HP ScanJet IIC RGB scanner at 400 pixels per inch. The scanner maps the colors into the RGB monitor gamut causing clipping of some saturated colors and re-mapping of the primary colors. For calibration, the black patch was mapped to 0,0,0, and the paper white to 255,255,255. The RGB values correspond to Sony Trinitron phosphors with gamma 1.8 (Standard Macintosh color use). The resulting scanned image is referred to as the Scanned Color Chart. The 200 pixel/inch scan was achieved using subsampling and pixel averaging. Each image was constructed as an uncompressed baseline TIFF file with the RGB color space used for the image input data. Subsequently, the files were converted to the CIELAB color space to be consistent with the color facsimile recommendations.

Digitization of the gray scale images presented no special problems, since they are true gray scale photographs. However, an artifact was generated in scanning the Color Test Chart. The target color image is screened (i.e., printed using a process which converts the 3-channel, continuous tone data to 4-color separations in which the intermediate tone levels are represented with a regular pattern of color dots), and therefore wavelike patterns can be seen in certain areas. This is an artifact of the frequency difference between the screen and the scan.

A problem was noted regarding the paper and ink used in the printing process of the Color Test Chart proof. While the paper, cyan ink, and magenta ink do not appear to fluoresce, the yellow ink fluoresces, and may cause perceptible color variation depending on the illuminant. In addition, the yellow is out of the video color gamut, as measured under D65 illumination. These observations pertain to the proof copies of the color test chart.

2.3.4 Computer-generated Color Chart

The Computer-generated Color Chart image shown in Figure 21 is also derived from ITU-T T.23 Test Chart No.6 at two resolutions. A digital bitmap representation of the Color Test Chart provides experimenters with the optimum test input source without distortions or losses created during printing, scanning, and color space conversions. The digital version of the Color Test Chart is called the Computer-generated Color Chart. The Computer-generated Color Chart is an accurate implementation of the colors and luminance values in the original Color Test Chart. The digital bitmap version of the Color Test Chart (Computer-generated Color Chart) complements the Scanned Color Chart.

This version is an accurate bit map reconstruction of the Color Test Chart rendered at 400 pixels/inch with anti-aliased fonts in the CMYK color space. The image was converted to CIELAB assuming a SWOP (standard web offset proofing) color set with twenty percent dot gain. The image was subsampled with pixel averaging to produce the 200 pixel per inch representation of the Color Test Chart. The color conversion may be further refined when better conversion data becomes available. The screens used in the printed color chart are not reproduced, but rather continuous tones have been generated.

2.3.5 Kids with Toys

Figure 22 is the Kids With Toys photograph that demonstrates higher sharpness for fine detail in the stuffed animals and the faces and provides for a range of textures and patterns. Widespread variations in luminance, hue, and saturation are made possible by the presence of both bright and pastel colors. Also, the image is rich in slowly varying color textures broken up with sharp color boundaries.

2.3.6 Computer-Generated Spheres

Figure 23 is a computer-generated simulation of spheres. This image utilizes shadings that produce a three-dimensional effect. The image contains differently colored spheres at a number of various sizes on a black background. This provides a wide range of color shadings with distinct edges. In general, each sphere is one color, shaded to give a three-dimensional appearance. The gradual transition in color for the

shading of each sphere provides an excellent medium for discerning possible contouring effects. If contouring is present, it will usually manifest itself as a series of concentric circles with slightly different colors. The edges of the spheres also provide sharp boundaries against both the black background and other spheres.

2.3.7 Graphics-Art

Figure 24 is a graphic image from a magazine cover that exhibits a three-dimensional effect. It uses pastel colors to denote surfaces and fine black lines to enhance details. It contains a number of repetitive patterns coupled with sharp boundaries between the various colors.

3 Test CD-02 Image Storage

All of the images in the Standard Image Set are stored in TIFF and use ".tif" as the file name extension. The images are contained in the \IMAGES subdirectory on the Test CD-02 CD-ROM. All files on the Test CD-02 CD-ROM conform to the ISO 9660 format and are optimized for the MS-DOS environment. The CD-ROM file structure is based on the Level 1 Interchange format defined by the ISO 9660 standard. In order for a computer operating system to access the Standard Image Set from CD-ROM, the operating system must contain software that interprets the ISO 9660 file structure. This software is typically an extension to the operating system software. In order to achieve compatibility across many computer platforms, the CD-ROM was restricted to a Level 1 Interchange format which is the most universally supported mode. The CD-ROM may also be read on a UNIX platform and Macintosh computer.

The three classes of images are stored on Test CD-02 as follows. The bi-level images are stored using ITU-T Rec. T.6 compression (Modified Modified Read or MMR). Due to the compression achieved for the stored images, the storage requirements listed in the CD-02 File Reference Guide are greater than the actual storage space required by each bi-level image on the CD-ROM. Table 1 shows the actual file storage space requirements for each image. Since T.6 compression is image preserving, no information is lost. The gray-scale images are stored with the WordPerfect 5.1 TIFF flavor. The color images are stored as class R TIFF 6.0 files. Class R is a baseline implementation of the TIFF file format that does not use compression. The color images are stored in both the CIELAB color space and the RGB color space.

4 Test CD-02 Architecture and Duplication

A set of 200 Test CD-02 CD-ROMs were manufactured from the master disk supplied by DIS. The Test CD-02 master CD-ROM contains all of the images referenced in the ITU-T Recommendation T.24 except for the highest resolutions (400

and 480 pixel/inch) of the Half-tone Chart. These two images are missing from the DIS personal computer-based archive. New printed materials (Booklet and Inlay Card) and CD label artwork were made for the new Test CD-02 CD-ROM.

A number of refinements were made to the new Test CD-02 CD-ROM. These refinements were performed to both the documentation files contained on the CD-ROM and to the printed materials that are placed in the jewel box case. The utilization of a more consistent file naming convention was used for identifying the images. Each image file name uses a reference in the first three characters to its appropriate figure number in the ITU-T Recommendation T.24. The new file names were used in the booklet. Also, the image dimensions in both pixels and inches were added to the File Reference Guide which makes up three pages of the CD-ROM booklet. The fourth page is the front cover to the jewel box case. New, two-color artwork was added to the front cover (rear of booklet) and the Inlay card to clearly identify the CD-ROM "Standard Image Set (Beta Test CD-02)". The new artwork was made in order to avoid confusion with the previously released CD-ROM "Standard Image Set, CD-01".

In addition to the images stored on the CD-ROM, a number of documentation files were added to give the user information on the image file format and image content. The README file provides a directory to all of the documentation file names and their content. The README file also provides the user with information about the image content and the TIFF parameters used in storing the images. A very brief description of the image content is also included in the README file. The Image File Specifications file (IMGSPEC.ASC) which is stored in ASCII contains the image file names and parameters of the Standard Image Set (Beta-Test CD-02). Also included on the CD-ROM are three separate files of the ITU-T Recommendation T.24 stored in ASCII text format, in Word for Windows 2.0 format and in Postscript. The TIFF 6.0 specification was included as a Postscript file for user reference to the Tagged Image File Format version 6.0.

5 Test CD-02 Distribution

A few prototypes of the Test CD-02 CD-ROM were distributed to attendees at the WG1 meeting held in March. Thirty copies of the finished product were taken to the ITU-T Study Group 8 meeting in Geneva and distributed to key members. Copies of the Test CD-02 were also sent to members of the TIA TR-29 committee, the X3L3 committee, and other interested parties for comments.

6 JPEG Continuous-Tone Test Images

6.1 CD-ROM Contents

This section describes a collection of images on CD-ROM which was assembled by Delta Information Systems. The CD-ROM was created so that the performance of different proposed JPEG compression algorithms could be evaluated and compared. The test images were selected to represent a wide range of image classes. The image classes on the CD-ROM include video images, scanned images, medical imagery, fine works of art, computer generated diagrams, aerial photographs, and compound documents.

The current version of the CD-ROM contains 30 images in a variety of file formats and color spaces. The images are stored in the TIFF format, the RAW format or the Sun Raster format (for grayscale images). The image color spaces consist of RGB, CMYK, CIE Lab, YUV, and grayscale. The SCID images represent imagery from the Standard color image data source. For more information, the reader is referred to the ISO report document ISO/DIS 12640, titled "Graphic technology - Prepress digital data exchange - Standard color image data (SCID)". This document was balloted May 4, 1995 and received final approval in December, 1995.¹ A text file which describes the images is included on the CD-ROM. Table 4 lists the characteristics of each image on the CD-ROM. Hard copies of the images (in grayscale) are included in Appendix B of this report. At the time of this writing, fifteen copies of the CD-ROM have been copied and distributed to the JPEG algorithm proposers.

TABLE 4 JPEG Test Image Specifications

JPEG Continuous-tone Test Image Set						
Filename	Source	Image Description	Color Space	Bits per component	Image Dimensions Pixels (W x H)	File Size (Bytes)
HOTEL	CCIR 601	Hotel	YUV	8	720 x 576	830,932
GOLD	CCIR 601	Gold	YUV	8	720 x 576	830,932
BIKE	SCID	N5 "Bike"	CMYK	8	2048 x 2560	20,972,544
WOMAN	SCID	N1 "Portrait"	CMYK	8	2048 x 2560	20,972,544
CAFE	SCID	N2 "Cafeteria"	CMYK	8	2048 x 2560	20,972,544
TOOLS	Crosfield drum scan	Tools	CMYK	8	1524 x 1200	7,315,854
BIKE3	Crosfield digital scan	Motorcycle	RGB	8	781 x 919	2,153,821
WATER	PhotoCD	Water	RGB	8	2,048 x 3072	18,899,574

JPEG Continuous-tone Test Image Set						
Filename	Source	Image Description	Color Space	Bits per component	Image Dimensions Pixels (W x H)	File Size (Bytes)
CATS	PhotoCD	Cats	RGB	8	2,048 x 3072	18,899,568
AERIAL1	Aerial Photo	Aerial 1	RGB	11	1024 x 1024	6,291,992
AERIAL2	Aerial Photo	Aerial 2	RGB	8	720 x 1024	2,212,136
CMPND1	Computer generated	Compound 1	RGB	8	512 x 768	1,179,892
CMPND2	Computer generated	Compound 2	RGB	8	1024 x 1400	4,301,404
FINGER	Fingerprint	I1010092	mono	8	512 x 512	262,482
X_RAY	medical x-ray	X-ray- "XR1.1"	mono	12	2048 x 1680	6,881,312
CR	Computer radiology	CR "CR-ABDMN"	mono	10	1744 x 2048	7,143,456
CT	Computer tomography	CT "CT1.1"	mono	12	512 x 512	524,320
US	Ultrasound	Ultrasound "US1.DCM"	mono	8	512 x 488	229,808
MRI	Magnetic resonance	MRI "MR1.1"	mono	11	256 x 256	131,104
FAXBALLS	Computer generated	"FAXBALLS"	CIELab	8	1,024 x 512	1,577,164
PC	Computer generated	Printed Circuit Board Layout	CIELab	8	1575 X 2185	10,324,620
CHART	Computer generated	"T.23 Test Chart No 6 - 4 Color Printing Facsimile Test Chart"	CIELab	8	1752 x 2375	12,502,266
CHART_S	Scan of chart	"T.23 Test Chart No 6 - 4 Color Printing Facsimile Test Chart"	RGB	8	1688 x 2347	11,885,812
BAND1	Sensor Array	"Aerial Image - Blue band"	BLUE	8	736 x 736	541,934
BAND2	Sensor Array	"Aerial Image -Green band"	GREEN	8	736 x 736	541,934
BAND3	Sensor Array	"Aerial Image -Red band"	RED	8	736 x 736	541,934
BAND4	Sensor Array	"Aerial Image - Near IR band"	Near IR	8	736 x 736	541,934
EDUC	Scan	Fine Arts 1, engraving	mono	8	2850 x 4096	11,676,100
INGRES8	Scan	Fine Arts 2, painting	RGB	8	4088 x 4608	56,512,700
INGRES16	Scan	Fine Arts 3, painting	RGB	12	4088 x 4608	113,025,212
TOTAL IMAGE STORAGE SPACE REQUIREMENTS						360,677,829

The following paragraphs contain further information about the format and usage of the files on the CD-ROM.

Several of the images on the disk are stored in more than one format for convenience. For example, the PhotoCD images (WATER and CATS) are also stored with each color plane (red, green, and blue) contained in a separate TIFF file. The HOTEL and GOLD images are also stored with the color planes separated into individual color plane files (one each for Y, U, and V). When the images are used for JPEG algorithm evaluation, each color band must be compressed separately from the others. Therefore, it is simpler for the evaluation to maintain separate files for each color component.

The two aerial photo images are supplied in both TIFF and band sequential (BSQ) formats. The BSQ format has no header and is included on the CD-ROM in case difficulty is encountered handling the TIFF images. AERIAL1 is the overhead shot of an industrial site with railroad cars and water. AERIAL2 is the overhead shot of a coast line with a curving bridge. The BAND1, BAND2, BAND3 and BAND4 images on the CD-ROM are produced by an aerial sensor array which provides a near-infrared band as well as bands for red, green, and blue. BAND4 contains the near-infrared image. The scene in these images is the same as that in the AERIAL2 image. The four color bands in the BAND images are stored in both TIFF and RAW files.

The medical images are stored in Sun Raster files with the YY extension. The FAXBALLS and CHART images are stored in the CIE Lab color space with the TIFF Photometric Interpretation tag set to RGB. The PC image is a computer generated cad drawing of a printed circuit board layout. It is stored in the CIE Lab color space with the TIFF Photometric Interpretation tag set to LAB.

The fine art images are all stored in TIFF files. The fine art scanned image of a painting is supplied in both 8 bits per color plane (INGRES8) and 16 bits per color plane (INGRES16). The fine art scanned image of an engraving (EDUC) is an 8 bit mono or grayscale image.

6.2 JPEG Compression Evaluation Using Test Images

The JPEG/JBIG working group has recently developed quantitative evaluation criteria for lossless continuous-tone image compression². A copy of the evaluation criteria is included in Appendix C of this report. According to the evaluation criteria, JPEG compression algorithms are scored on both lossless and near-lossless performance. The lossless compression score for each algorithm is determined by performance and memory cost. The near-lossless compression score is determined by the root mean squared error (RMSE) as well as the performance and memory requirements of the algorithm.

The evaluation criteria and test images are useful tools for the comparison of proposed JPEG compression algorithms. The test images on the CD-ROM were

encoded by nine proposed JPEG compression algorithms and the evaluation criteria was used to compare the performance of the algorithms. Six corporations developed compression algorithms including RICOH, Mitsubishi, NEC, Canon, Hewlett Packard, and Kodak. Academic institutions contributed three proposals. The University of California, Santa Clara (UCSC) submitted two JPEG compression algorithms including one by Don Speck and another by Glen Langdon, et. al. The remaining proposal came from three researchers at separate universities, namely Xiaolin Wu, Nasir Memon, and Khalid Sayood.

Each of the organizations listed above used their JPEG algorithm to compress the images on the CD-ROM. After compressing the images, they returned data for each image including the compressed file sizes and root mean squared error to Delta. This information was entered into a spreadsheet and the scores were calculated using the evaluation criteria in Appendix C. To simplify analysis of the results, the score from images in each image class were combined into an average score for that class. Tables 5 to 11 display the average scores for each image class. The compression score is given in bits per symbol and the overall score is shown as a percentage. At the top of each table the images contained in the class are listed along with the lossless compression achieved by the original JPEG algorithm.

NOTE: Some of the images on the current CD-ROM do not appear in any of the following tables because they were added after the algorithm evaluations had been completed.

TABLE 5 - Algorithm Scores For Video Image Class

Images included: HOTEL, GOLD
 JPEG Lossless compression (bps): 4.144

Contributor	RICOH	Mitsubishi	UCSC (1)	UCSC (2)	NEC	CANON	WMS	HP	KODAK
Algorithm Name	CREW	CLARA	ALCM	Jslug	LTC	APEC	CALC	LOCO-I	DARC
Lossless (bps)	4.07	3.97	3.88	3.90	4.09	3.91	3.77	3.90	4.28
Score	93.23	96.66	98.16	97.40	93.87	96.20	100.00	97.74	91.95
Lossy 1 (bps)	2.67	2.44	2.38	2.38	2.48	2.44	2.33	2.44	2.77
Score	79.57	92.82	96.21	96.03	89.61	92.02	100.00	92.74	76.98
Lossy 2 (bps)	2.12	1.81	1.75	1.73	1.82	1.84	1.74	1.90	2.18
Score	77.62	94.21	98.31	99.44	93.08	92.00	98.74	89.49	76.60
Lossy 3 (bps)	1.80	1.45	1.36	1.35	1.43	1.46	1.41	1.61	1.85
Score	73.84	92.08	98.88	99.41	93.36	92.01	95.89	83.04	72.87
Lossy 7 (bps)	1.22	0.86	0.65	0.65	0.70	0.70	0.76	1.04	1.23
Score	59.78	77.37	99.00	98.94	92.03	94.00	88.83	68.90	60.81

TABLE 6 - Algorithm Scores For Prepress/SCID Image Class

Images included: BIKE, WOMAN, CAFE, TOOLS
 JPEG Lossless compression (bps): 4.8

Contributor	RICOH	Mitsubishi	UCSC (1)	UCSC (2)	NEC	CANON	WMS	HP	KODAK
Algorithm Name	CREW	CLARA	ALCM	Jslug	LTC	APEC	CALC	LOCO-I	DARC
Lossless (bps)	4.72	4.54	4.43	4.48	4.69	4.50	4.30	4.53	4.79
Score	92.13	96.46	98.06	96.89	93.63	95.57	100.00	96.53	92.95
Lossy 1 (bps)	3.33	3.09	3.03	3.06	3.20	3.15	2.95	3.12	3.39
Score	79.16	92.15	94.50	92.48	84.32	87.11	100.00	88.30	77.53
Lossy 2 (bps)	2.75	2.47	2.43	2.44	2.56	2.55	2.37	2.52	2.78
Score	80.33	95.01	96.42	95.76	88.27	89.13	99.86	89.72	79.76
Lossy 3 (bps)	2.42	2.09	2.06	2.07	2.15	2.20	2.02	2.17	2.42
Score	79.14	95.69	97.10	96.29	91.08	89.18	100.00	89.11	79.60
Lossy 7 (bps)	1.71	1.35	1.29	1.28	1.35	1.38	1.32	1.51	1.72
Score	74.11	93.00	98.20	98.64	92.20	91.99	95.91	81.40	73.63

TABLE 7 - Algorithm Scores For Scanned Image Class

Images included: BIKE3, WATER, CATS, GRAPHIC
 JPEG Lossless compression (bps): 2.942

Contributor	RICOH	Mitsubishi	UCSC (1)	UCSC (2)	NEC	CANON	WMS	HP	KODAK
Algorithm Name	CREW	CLARA	ALCM	Jslug	LTC	APEC	CALC	LOCO-I	DARC
Lossless (bps)	3.03	2.83	2.78	2.78	2.87	2.84	2.68	2.87	2.99
Score	89.95	94.77	96.18	95.89	93.36	93.31	98.26	93.85	91.11
Lossy 1 (bps)	2.08	1.81	1.75	1.82	1.85	1.91	1.74	1.93	2.08
Score	74.07	90.60	95.00	88.73	83.85	82.25	97.16	78.35	71.40
Lossy 2 (bps)	1.71	1.41	1.33	1.33	1.42	1.49	1.37	1.56	1.68
Score	69.42	87.49	92.72	92.31	83.05	80.30	87.75	73.37	68.00
Lossy 3 (bps)	1.46	1.16	1.08	1.08	1.15	1.21	1.20	1.32	1.43
Score	67.80	86.13	92.72	91.70	85.31	81.86	84.81	71.42	67.90
Lossy 7 (bps)	1.02	0.74	0.60	0.62	0.66	0.68	0.85	0.84	1.00
Score	56.37	72.04	94.56	87.92	77.32	85.07	65.80	62.25	55.76

TABLE 8 - Algorithm Scores For Aerial Photograph Class

Images included: AERIAL1, AERIAL2
 JPEG Lossless compression (bps): 6.565

Contributor	RICOH	Mitsubishi	UCSC (1)	UCSC (2)	NEC	CANON	WMS	HP	KODAK
Algorithm Name	CREW	CLARA	ALCM	Jslug	LTC	APEC	CALC	LOCO-I	DARC
Lossless (bps)	6.59	6.42	6.23	6.38	6.48	6.31	6.07	6.31	6.76
Score	91.76	96.23	97.19	95.77	94.77	95.96	100.00	97.83	92.88
Lossy 1 (bps)	5.12	5.00	4.79	4.91	5.08	4.95	4.84	4.99	5.25
Score	82.02	90.61	99.92	93.94	85.73	90.47	97.87	89.02	78.97
Lossy 2 (bps)	4.48	4.34	4.13	4.26	4.39	4.30	4.22	4.35	4.57
Score	83.19	90.83	99.97	94.57	88.64	92.22	95.37	89.89	81.68
Lossy 3 (bps)	4.07	3.92	3.72	3.84	3.97	3.90	3.82	3.93	7.36
Score	82.88	90.61	100.00	95.13	89.43	91.71	94.98	90.67	59.61
Lossy 7 (bps)	3.20	3.02	2.87	2.96	3.05	3.03	2.92	3.03	3.26
Score	82.65	92.12	100.00	96.01	91.79	92.49	96.87	91.75	82.61

TABLE 9 - Algorithm Scores For Compound Documents Class

Images included: CMPND1, CMPND2, CHART, CHART_S
 JPEG Lossless compression (bps): 1.889

Contributor	RICOH	Mitsubishi	UCSC (1)	UCSC (2)	NEC	CANON	WMS	HP	KODAK
Algorithm Name	CREW	CLARA	ALCM	Jslug	LTC	APEC	CALC	LOCO-I	DARC
Lossless (bps)	2.38	1.67	1.81	1.85	1.78	1.66	1.60	1.81	1.93
Score	75.71	97.39	91.73	89.87	92.01	96.49	99.78	91.79	88.18
Lossy 1 (bps)	1.71	1.09	1.20	1.24	1.22	1.13	1.12	1.27	1.35
Score	56.49	97.30	79.81	77.37	77.78	91.92	96.20	72.38	69.52
Lossy 2 (bps)	1.44	0.86	0.95	0.98	0.97	0.88	0.99	1.05	1.11
Score	56.71	98.49	83.06	80.95	79.75	95.47	82.73	72.66	69.99
Lossy 3 (bps)	1.27	0.72	0.81	0.82	0.83	0.74	0.95	0.91	0.97
Score	56.19	89.03	86.67	84.74	81.67	97.37	73.47	76.85	70.13
Lossy 7 (bps)	0.93	0.47	0.52	0.53	0.50	0.49	0.58	0.66	0.71
Score	54.72	95.92	84.82	83.96	82.20	95.19	82.82	67.82	65.54

TABLE 10 - Algorithm Scores For Medical Image Class

Images included: FINGER, XRAY, CR, CT, US, MRI
 JPEG Lossless compression (bps): 5.18

Contributor	RICOH	Mitsubishi	UCSC (1)	UCSC (2)	NEC	CANON	WMS	HP	KODAK
Algorithm Name	CREW	CLARA	ALCM	Jslug	LTC	APEC	CALC	LOCO-I	DARC
Lossless (bps)	5.11	5.06	4.85	4.80	5.01	4.93	4.73	4.92	5.22
Score	92.14	95.58	97.24	98.18	95.22	95.71	99.65	96.93	93.25
Lossy 1 (bps)	3.68	3.61	3.41	3.38	3.56	3.51	3.59	3.54	3.88
Score	79.71	85.91	93.68	95.60	85.78	89.24	86.44	87.05	74.08
Lossy 2 (bps)	3.08	2.97	2.81	2.76	2.91	2.93	2.99	2.91	3.21
Score	81.32	88.20	94.79	96.96	88.67	89.60	87.64	90.00	77.73
Lossy 3 (bps)	2.70	2.57	2.40	2.37	2.50	2.53	2.64	2.53	2.83
Score	81.10	89.60	95.59	96.98	89.43	89.43	85.66	87.75	77.34
Lossy 7 (bps)	2.00	1.77	1.59	1.56	1.66	1.73	1.80	1.74	2.01
Score	75.40	87.11	97.57	98.73	91.91	89.38	86.72	88.82	77.20

TABLE 11 - Algorithm Scores For Computer Generated Image Class

Images included: FAXBALLS
 JPEG Lossless compression (bps): 0.844

Contributor	RICOH	Mitsubishi	UCSC (1)	UCSC (2)	NEC	CANON	WMS	HP	KODAK
Algorithm Name	CREW	CLARA	ALCM	Jslug	LTC	APEC	CALC	LOCO-I	DARC
Lossless (bps)	1.15	0.60	0.82	0.79	0.61	0.89	0.75	1.06	1.08
Score	66.25	99.97	82.38	83.50	97.90	76.94	87.09	71.34	70.41
Lossy 1 (bps)	0.83	0.34	0.38	0.36	0.41	0.30	0.70	0.69	0.70
Score	41.44	84.44	75.43	79.10	67.09	98.97	46.40	46.45	46.34
Lossy 2 (bps)	0.67	0.23	0.30	0.28	0.33	0.20	0.65	0.55	0.52
Score	38.16	81.73	69.57	72.62	61.63	98.97	40.13	42.88	44.24
Lossy 3 (bps)	0.57	0.18	0.24	0.23	0.27	0.16	0.58	0.47	0.43
Score	37.62	88.09	69.61	71.89	63.09	98.97	38.59	43.21	45.90
Lossy 7 (bps)	0.36	0.09	0.15	0.14	0.17	0.10	0.44	0.30	0.25
Score	40.18	91.95	72.76	75.22	64.13	96.44	37.55	46.84	52.09

Overall, the best performing algorithms were those from UCSC and the trio of Wu, Memon, and Sayood (WMS). These were the dominant algorithms for five of the seven image classes. The proposals from Canon and Mitsubishi also performed well for the computer generated and compound documents class, respectively. For most image classes, the algorithm which provides the best lossless compression is not the same as the one which provides the best near-lossless compression. Generally, the algorithm developed by WMS is best for lossless compression while the UCSC algorithms score higher when greater compression is needed. This result implies that

perhaps two algorithms should be selected and negotiated in the facsimile protocol depending on how much lossiness can be tolerated. It might also be possible to use the lossless portion of one algorithm and the near-lossless portion of another for the best overall performance.

7 Recommendations

It is recommended that a new CD-ROM be created for the ITU-T. The new CD-ROM will have the CIELAB color images stored in TIFF with the Photometric Interpretation Tag set to the CIELAB color space. The current test CD-ROM has the CIELAB images stored with the Photometric tag set to RGB for compatibility with most older TIFF readers. By using the RGB tag, readability of the image file was ensured. However, this led to a problem when the files were viewed since the color space indicated by the TIFF tag did not match the file data and the image was displayed in the wrong color space. Presently, TIFF readers have become available that can correctly interpret the CIELAB Photometric Interpretation Tag and are capable of displaying the data in the CIELAB color space.

Also, a production copy of the color test chart with spectrophotometric accuracy can be achieved by using a micro densitometer for the scanning process. Therefore, it is also recommended that a normative reference for the Scanned Color Test Chart be generated using this technique.

REFERENCES

- [1] ISO/DIS 12640, titled "Graphic technology - Prepress digital data exchange - Standard color image data (SCID)". Document is currently awaiting ISO publication.
- [2] ISO/IEC JTC1/SC29/WG1, *Evaluation criteria for the lossless continuous-tone image compression work item*, JTC 1/29.12, March 1995.

Appendix A
ITU-T Approved Image Set

THE SLEREXE COMPANY LIMITED

SAPORS LANE - BOOLE - DORSET - BH 25 8 ER

TELEPHONE BOOLE (945 13) 51617 - TELEX 123456

Our Ref. 350/PJC/EAC

18th January, 1972.

Dr. P.N. Cundall,
Mining Surveys Ltd.,
Holroyd Road,
Reading,
Berks.

Dear Pete,

Permit me to introduce you to the facility of facsimile transmission.

In facsimile a photocell is caused to perform a raster scan over the subject copy. The variations of print density on the document cause the photocell to generate an analogous electrical video signal. This signal is used to modulate a carrier, which is transmitted to a remote destination over a radio or cable communications link.

At the remote terminal, demodulation reconstructs the video signal, which is used to modulate the density of print produced by a printing device. This device is scanning in a raster scan synchronised with that at the transmitting terminal. As a result, a facsimile copy of the subject document is produced.

Probably you have uses for this facility in your organisation.

Yours sincerely,

Phil.

P.J. CROSS
Group Leader - Facsimile Research

Registered in England: No. 2038
Registered Office: 80 Vicars Lane, Ilford, Essex.

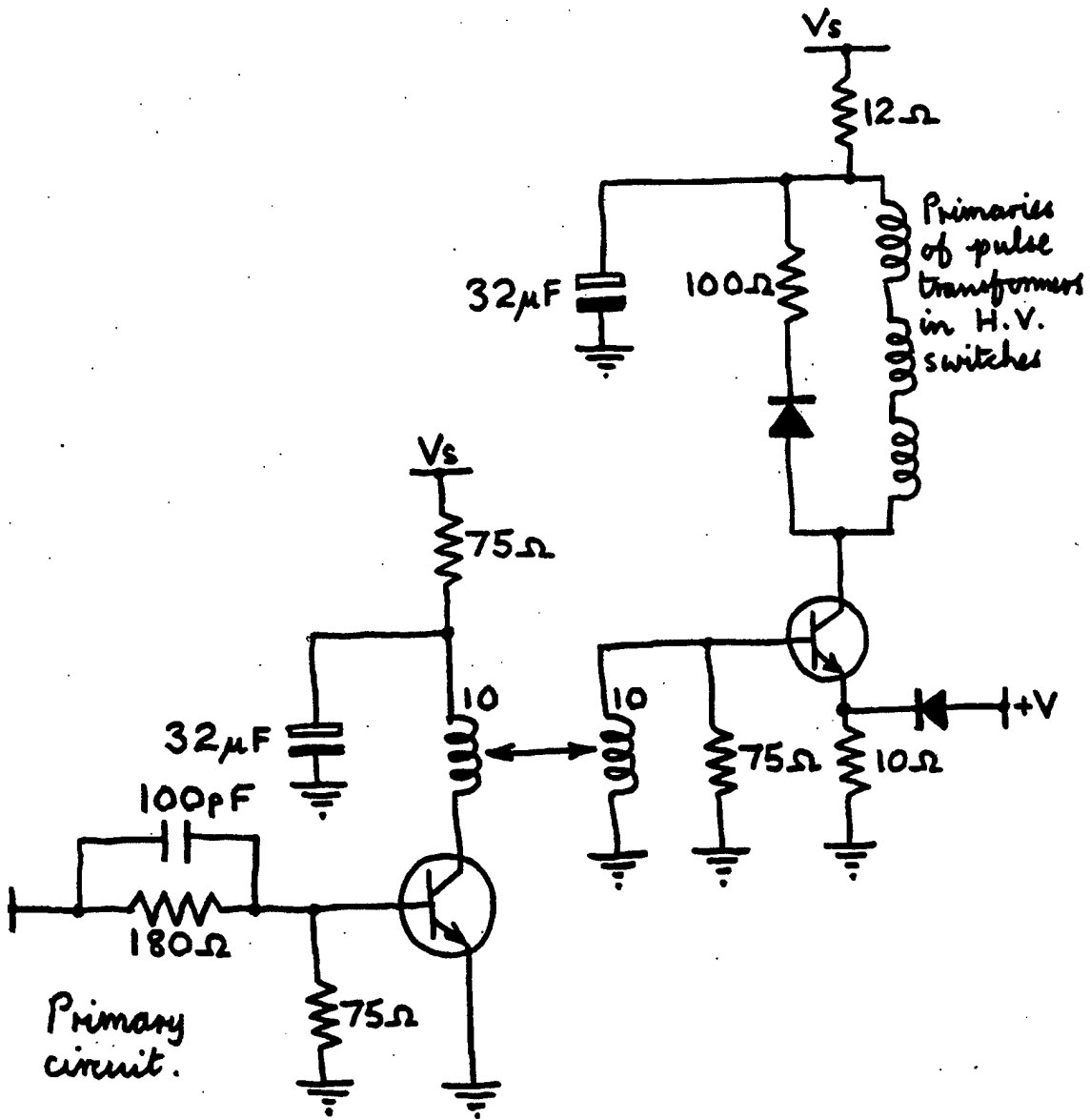

This is current driver circuit.

Phil.

22-9-71

Figure 2
ITU-T Document No. 2

ETABLISSEMENTS ABCDEFG
 SOCIÉTÉ ANONYME AU CAPITAL DE 300 000 F
 20, RUE DU XVUTRSTBOL F 00000 NTBCLAG
 Tél. : (38) 24.02.32 Adr. Tg. : NRVLJROLM
 Téléx : 31586 F IN : 718400070257
 Transporteur (ou Transitaire)
 M. M. DUPONT Frères
 8 quai des blofish F 0000 NTBCLAG

Mot directeur			
CLASSEMENT	FACTURE INVOICE	Exemplaire 15	
CODE CLIENT 2-04599	DATE 7-7-74	NUMERO 06	FEUILLET 01
Votre commande	du 74-2-Numéro 438		
Notre offre AZ/B7	du 74-1-Numéro 12		

LIVRAISON
 5, rue XYZ
 99000 VILLE

FACTURATION
 12, rue ABCD BP 15
 99000 VILLE

DOMICILIATION BANCAIRE DU VENDEUR			PAYS D'ORIGINE	PAYS DE DESTINATION
CODE BANQUE	CODE GUICHET	COMPTE CLIENT	CONDITIONS DE LIVRAISON	DATE 74-03-03
ORIGINE	TRANSPORTS DESTINATION	MODE	LICENCE D'EXPORTATION	NATURE DU CONTRAT (monnaie)
Pays 1	Etat 2	Air	CONDITIONS DE PAIEMENT	FAB (échéance, %...)

MARQUES ET NUMEROS MARKS AND NUMBERS		NOMBRE ET NATURE DES COLIS : DÉNOMINATION DE LA MARCHANDISE NUMBER AND KING OF PACKAGES: DESCRIPTION OF GOODS		NOMEN- CLATURE STATISTICAL No.	MASSE NETTE NET WEIGHT MASSE BRUTE GROSS WEIGHT	VALEUR VALUE DIMENSIONS MEASURE- MENTS
74.21.456.44.2 A		1 Composants		U 123/4	5 kg 8 kg	1400 X 13x10x6
QUANTITE COMMANDÉE ET UNITÉ QUANTITY ORDERED AND UNIT	N° ET REF. DE L'ARTICLE	DESIGNATION		QUANTITE LIVRÉE ET UNITÉ QUANTITY DELIVERED AND UNIT	PRIX UNITAIRE UNIT PRICE	MONTANT TOTAL TOTAL AMOUNT
2	AP-809	Circuit intégré		2	104,33 F	208,66 F
10	S8-T4	Connecteur		10	83,10 F	831,00 F
25	Z107	Composant indéterminé		20	15,00 F	300,00 F

Costs	Débours	Inclus	Non inclus
Packing	Emballages		92,14
Freight	Transport		
Insurance	Assurances		
Total Invoice amount	Montant total de la facture		1431,80
Instalment	Acomptes		
NET TO BE PAID	NET A RÉGLER		1431,80

Figure 3
 ITU-T Document No. 3

L'ordre de lancement et de réalisation des applications fait l'objet de décisions au plus haut niveau de la Direction Générale des Télécommunications. Il n'est certes pas question de construire ce système intégré "en bloc" mais bien au contraire de procéder par étapes, par paliers successifs. Certaines applications, dont la rentabilité ne pourra être assurée, ne seront pas entreprises. Actuellement, sur trente applications qui ont pu être globalement définies, six en sont au stade de l'exploitation, six autres se sont vu donner la priorité pour leur réalisation.

Chaque application est confiée à un "chef de projet", responsable successivement de sa conception, de son analyse-programmation et de sa mise en oeuvre dans une région-pilote. La généralisation ultérieure de l'application réalisée dans cette région-pilote dépend des résultats obtenus et fait l'objet d'une décision de la Direction Générale. Néanmoins, le chef de projet doit dès le départ considérer que son activité a une vocation nationale donc refuser tout particularisme régional. Il est aidé d'une équipe d'analystes-programmeurs et entouré d'un "groupe de conception" chargé de rédiger le document de "définition des objectifs globaux" puis le "cahier des charges" de l'application, qui sont adressés pour avis à tous les services utilisateurs potentiels et aux chefs de projet des autres applications. Le groupe de conception comprend 6 à 10 personnes représentant les services les plus divers concernés par le projet, et comporte obligatoirement un bon analyste attaché à l'application.

II - L'IMPLANTATION GEOGRAPHIQUE D'UN RESEAU INFORMATIQUE PERFORMANT

L'organisation de l'entreprise française des télécommunications repose sur l'existence de 20 régions. Des calculateurs ont été implantés dans le passé au moins dans toutes les plus importantes. On trouve ainsi des machines Bull Gamma 30 à Lyon et Marseille, des GE 425 à Lille, Bordeaux, Toulouse et Montpellier, un GE 437 à Massy, enfin quelques machines Bull 300 TI à programmes câblés étaient récemment ou sont encore en service dans les régions de Nancy, Nantes, Limoges, Poitiers et Rouen ; ce parc est essentiellement utilisé pour la comptabilité téléphonique.

A l'avenir, si la plupart des fichiers nécessaires aux applications décrites plus haut peuvent être gérés en temps différé, un certain nombre d'entre eux devront nécessairement être accessibles, voire mis à jour en temps réel : parmi ces derniers le fichier commercial des abonnés, le fichier des renseignements, le fichier des circuits, le fichier technique des abonnés contiendront des quantités considérables d'informations.

Le volume total de caractères à gérer en phase finale sur un ordinateur ayant en charge quelques 500 000 abonnés a été estimé à un milliard de caractères au moins. Au moins les tiers des données seront concernées par des traitements en temps réel.

Aucun des calculateurs énumérés plus haut ne permettait d'envisager de tels traitements. L'intégration progressive de toutes les applications suppose la création d'un support commun pour toutes les informations, une véritable "Banque de données", répartie sur des moyens de traitement nationaux et régionaux, et qui devra rester alimentée, mise à jour en permanence, à partir de la base de l'entreprise, c'est-à-dire les chantiers, les magasins, les guichets des services d'abonnement, les services de personnel etc.

L'étude des différents fichiers à constituer a donc permis de définir les principales caractéristiques du réseau d'ordinateurs nouveaux à mettre en place pour aborder la réalisation du système informatif. L'obligation de faire appel à des ordinateurs de troisième génération, très puissants et dotés de volumineuses mémoires de masse, a conduit à en réduire substantiellement le nombre.

L'implantation de sept centres de calcul interrégionaux constituera un compromis entre : d'une part le désir de réduire le coût économique de l'ensemble, de faciliter la coordination des équipes d'informaticiens ; et d'autre part le refus de créer des centres trop importants difficiles à gérer et à diriger, et posant des problèmes délicats de sécurité. Le regroupement des traitements relatifs à plusieurs régions sur chacun de ces sept centres permettra de leur donner une taille relativement homogène. Chaque centre "gèrera" environ un million d'abonnés à la fin du VIème Plan.

La mise en place de ces centres a débuté au début de l'année 1971 : un ordinateur IRIS 50 de la Compagnie Internationale pour l'Informatique a été installé à Toulouse en février ; la même machine vient d'être mise en service au centre de calcul interrégional de Bordeaux.

Photo n° 1 - Document très dense lettre 1,5mm de haut -
Restitution photo n° 9

Cela est d'autant plus valable que $T\Delta f$ est plus grand. A cet égard la figure 2 représente la vraie courbe donnant $|\phi(f)|$ en fonction de f pour les valeurs numériques indiquées page précédente.

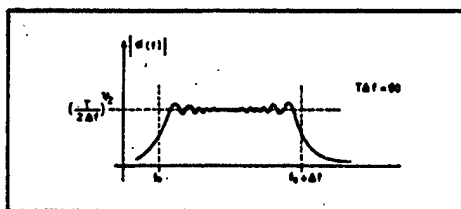

FIG. 2

Dans ce cas, le filtre adapté pourra être constitué, conformément à la figure 3, par la cascade :

— d'un filtre passe-bande de transfert unité pour $f_0 \leq f \leq f_0 + \Delta f$ et de transfert quasi nul pour $f < f_0$ et $f > f_0 + \Delta f$, filtre ne modifiant pas la phase des composants le traversant ;

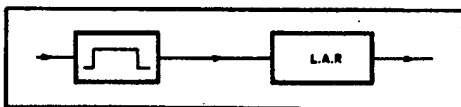

FIG. 3

— filtre suivi d'une ligne à retard (LAR) dispersive ayant un temps de propagation de groupe T_R décroissant linéairement avec la fréquence f suivant l'expression :

$$T_R = T_0 + (f_0 - f) \frac{T}{\Delta f} \quad (\text{avec } T_0 > T)$$

(voir fig. 4).

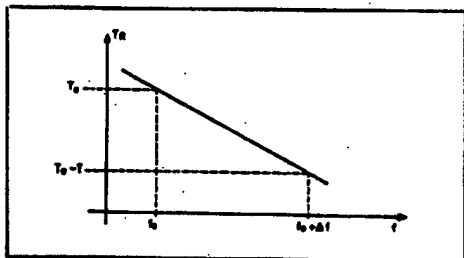

FIG. 4

telle ligne à retard est donnée par :

$$\varphi = -2\pi \int_0^f T_R df$$

$$\varphi = -2\pi \left[T_0 + \frac{f_0 T}{\Delta f} \right] f + \pi \frac{T}{\Delta f} f^2$$

Et cette phase est bien l'opposé de $|\phi(f)|$,

à un déphasage constant près (sans importance) et à un retard T_0 près (inévitabile).

Un signal utile $S(t)$ traversant un tel filtre adapté donne à la sortie (à un retard T_0 près et à un déphasage près de la porteuse) un signal dont la transformée de Fourier est réelle, constante entre f_0 et $f_0 + \Delta f$, et nulle de part et d'autre de f_0 et de $f_0 + \Delta f$, c'est-à-dire un signal de fréquence porteuse $f_0 + \Delta f/2$ et dont l'enveloppe a la forme indiquée à la figure 5, où l'on a représenté simultanément le signal $S(t)$ et le signal $S_1(t)$ correspondant obtenu à la sortie du filtre adapté. On comprend le nom de récepteur à compression d'impulsion donné à ce genre de filtre adapté : la « largeur » (à 3 dB) du signal comprimé étant égale à $1/\Delta f$, le rapport de compression est de $\frac{T}{1/\Delta f} = T\Delta f$

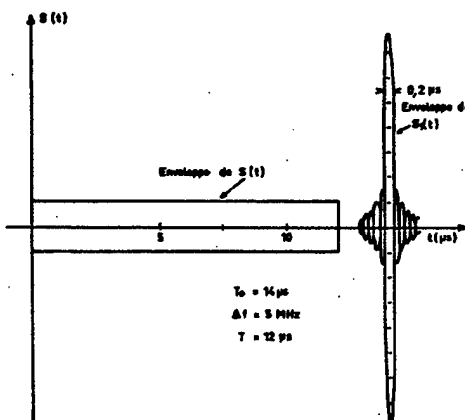
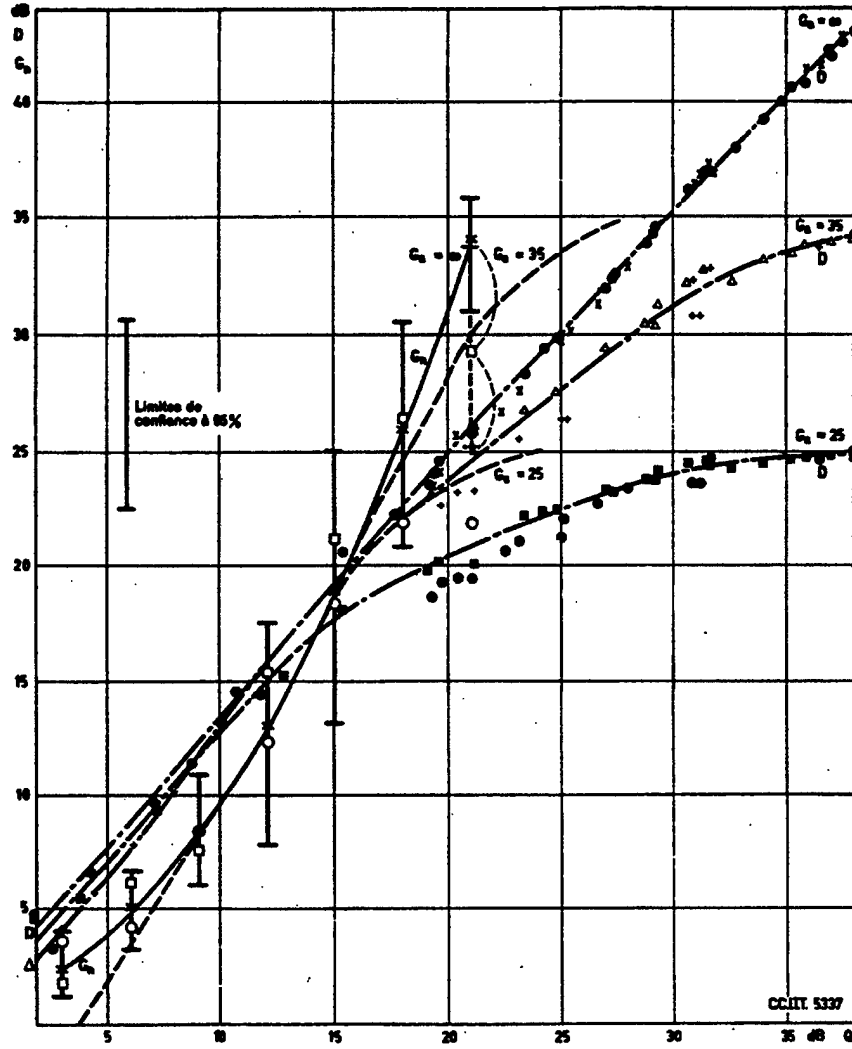

FIG. 5

On saisit physiquement le phénomène de compression en réalisant que lorsque le signal $S(t)$ entre dans la ligne à retard (LAR) la fréquence qui entre la première à l'instant 0 est la fréquence basse f_0 , qui met un temps T_0 pour traverser. La fréquence f entre à l'instant $t = (f - f_0) \frac{T}{\Delta f}$ et elle met un temps

$T_0 - (f - f_0) \frac{T}{\Delta f}$ pour traverser, ce qui la fait ressortir à l'instant T_0 , également. Ainsi donc, le signal $S(t)$



Courbes adaptées G_n (essais subjectifs) pour
 $G_n = 35$ dB $G_n = 25$ dB

[10] ———— x □ ○
 [23] - - - - -

Points calculés $D(G, G_n)$ pour
 $G_n = 25$ dB $G_n = 35$ dB

● ■ △ - dans la partie montante
 x ● + - dans la partie descendante

Courbes ———— x ———— △
 D(G, G_n)

FIGURE 3

TOME V — Question 18/XII, Annexe 6

Figure 6
 ITU-T Document No. 6

CCITTの概要

沿革

CCITTは、国際電気通信連合(ITU)の四つの常設機関(事務総局、国際周波数登録委員会、CCIR、CCITT)の一つとして、ITUの中でも、世界の国際通信上の諸問題を真先に取上げ、その解決方法を見出して行く重要な機関である。日本名は、国際電信電話諮問委員会と称する。

CCITTの前身は、CCIF(国際電信諮問委員会)とCCIT(国際電信諮問委員会)である。CCIFは、1924年にヨーロッパに「国際長距離電信諮問委員会」が設置され、これが1925年のパリ電信電話会議のとき、正式に、「国際電信諮問委員会」として万国電信連合の公式機関となったものである。CCITは、同じく1925年の会議のとき、CCIFと併立するものとして設置された。

そして、CCIFは、1956年の12月に第18回総会が開催されたのち、CCITは、同年同月に第8回総会が開催されたのち、併合されて現在のCCITTとなった。このCCITTは、CCIFとCCITが解散した直後、第1回総会を開催し、第2回総会は、1960年にニューデリーで、第3回総会は、1964年、ジュネーブで、第4回総会は、1968年、アルゼンチンで開催された。

CCIFとCCITが合併したのは、有線電気通信の分野、とくに伝送路について電信回線と電話回線とを技術的に分ける意味がなくなってきたこと、各国とも大體において、電信部門と電話部門は同一組織内にあること、CCIFの事務局とCCITの事務局の合併による効率増進等がおもな理由であった。

CCITTは、上述のように、ヨーロッパの国々によつて、ヨーロッパ内の電信・電話の技術・運用・料金の基準を定め、あるいは統一をはかっていたので、現在でも、その影響を受け、会合参加国は、ヨーロッパの国が多く、ヨーロッパで生起する問題の研究が多い。たとえば、1960年のCCITT勧告の中で、技術上配線する距離は約2,500kmであったが、これはヨーロッパ内領域を想定したものである。

しかしながら、1956年9月に敷設された大西洋横断電話ケーブルは、大陸間電信通信の自動化および半自動化への技術的可能性を与え、CCITTがこの問題を取り上げるに及び、CCITTの性格は漸次、汎世界的色彩を實質的に帯びるに至った。この汎世界的性格は第2次世界大戦後目まざましくなつたアジア・アフリカ植民地の独立に伴つてITUの構成員の中にこれらの国が加わり、ITUの中に新しい意見が導入されたことにも起因して、技術面、政治面の双方から導入されてき

た。CCITTの汎世界化は、1960年の第2回総会がニューデリーで開催されたことにもあらわれていた。この総会までは、CCIT、CCIFのいずれにしろ、アメリカやアジアで総会が開催されたことがなく、CCITT委員長も、ニューデリー総会の準備文書で、この点には注目すべきであるとのべている。

任務

ITUは、全権委員会、主管庁会議を始めとして、七つの機関をもち、それらの機関の権限と任務は国際電気通信条約に明記されている。そこで条約を参照してみるならば、CCITTの任務は、つぎのとおりとなっている。

「国際電信電話諮問委員会(CCITT)は、電信および電話に関する技術、運用および料金の問題について研究し、および意見を表明することを任務とする。」(1965年モントルー条約第187号)

「各国際諮問委員会は、その任務の遂行に当たつて、新しい国または発展の途上にある国における地域的および国際的分野にわたる電気通信の創設、発達および改善に直接関連のある問題について研究し、および意見を構成するように妥当な注意を払わなければならない。」(同第188号)

「各国際諮問委員会は、また、関係国の要請に基づき、その国内電気通信の問題について研究し、かつ、勧告を行なうことができる。」(同第189号)

上記第187号と第188号にいわゆる「意見」とは、フランス語の Avis から訳したもので、英語では、「勧告(Recommendation)」となっている。CCITTの表明する意見は、国際法には強制力をもたないものであつて、この点が、条約、電信規則、電話規則等各国を拘束する力をもっているものと異なる。もつとも意見とは称しても、技術的分野では、電信規則のごとき、各国政府が承認してその内容を実施する強制規則をもたないので、実際にある機器の仕様を定める場合には、多くの国の意見が統一されたこの「意見」に従わなければ、円滑な国際通信を行なうことができない場合が多い。この意見(または勧告)は、国際通信を行なう各国が直面する問題について、具体的意見を表明するもので、たとえば、大陸間ケーブルで大陸間電話を半自動化しようとする場合、その信号方式や取り扱う通話の種類および料金は、どのようにするかを研究して意見を表明する。したがつて、CCITTの活動は、つねに時代の最先端を行くもので、CCITTの活動方向は、そのまま世界の国際通信の活動方向であるといえる。

この意見は、また、電信規則以下のその他の規則のごとく、数年以上の間隔をもつて開催される主管庁会議というような大會議の決定をまたなくとも表明することができ、また、その改正も容易であるので、現在のように進歩の早い国際通信世界では、関係国の意見を統一した国際的見解としては非常に便利である。

memorandum

FROM: A.P. Spriggs Research	TO: G.V. Smith Project Planning
EXTN: 2041	DATE: 1-9-71

We know that, where possible, data is reduced to alphanumeric form for transmission by communication systems. However, this can be expensive, and also some data must remain in graphic form. For example, we cannot key-punch an engineering drawing or weather map.) I think we should realize that high speed facsimile transmissions are needed to overcome our problems in efficient graphic data communication. We need research into graphics data compression.

Any comments?

Albert

**WELL, WE
ASKED
FOR IT!**

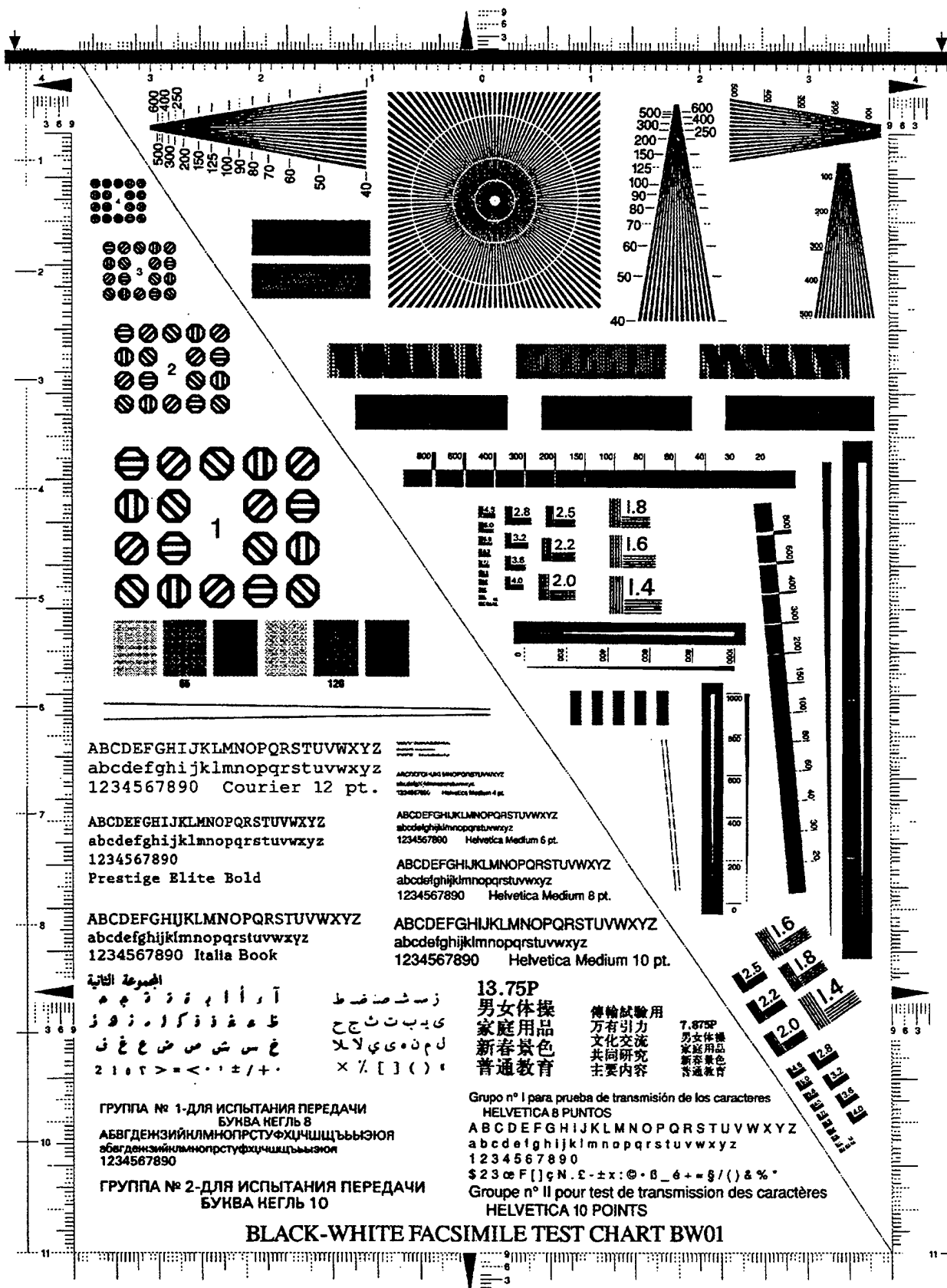
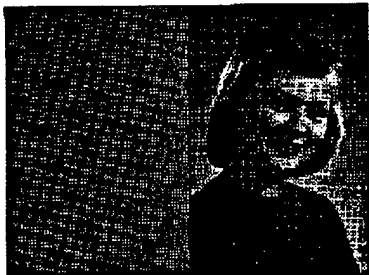
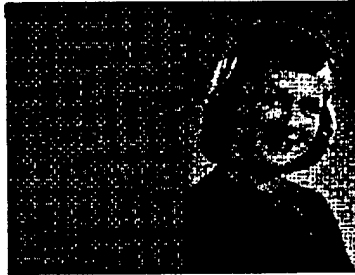

Figure 9
T.22 Test Chart No. 4

10 Point	dKfje giewo s1weo xcaqp cNvbm xiuyt rEdv2 dklJe giewo s1W3o xcaOp c9vbm xiuy dKfje giewo s1weo xcaqp cNvbm xiuyt rEdv2 dklJe rEdvj dklj5 giewo s1weo xca4G cnvbm x8uyt redVJ dkfje Gie6o s1wXo xcaqp dKfje giewo s1weo xcaqp cNvbm xiuyt rEdv2 dklJe Cnvbm xiuyt redVJ d48je giewo s1weo xca8Pp cnvbm x1Wyt redOJ dkfje giEwo s1weo xCa7p cnvbm xi26t rodvj KJfje giewo Slweo xca5Tp cnvbm xiuyt Bedvj dkfje gVew dKfje giewo s1weo xcaqp
8 Point	dKfje giewo s1weo xcaqp cNvbm xiuyt rEdv2 dklJe giewo s1W3o xcaOp c9vbm xiuy cikj kJK56 defje 83fdKfje giewo s1weo xcaqp cNvbm xiuyt rEdv2 dklJe rEdvj dklj5 giewo s1weo xca4G cnvbm x8uyt redVJ dkfje Gie6o s1wXo xcaqp KL3er ketch 3ksOd dKfje giewo s1weo xcaqp Cnvbm xiuyt redVJ d48je giewo s1weo xca8Pp cnvbm x1Wyt redOJ dkfje giEwo 3kooo kdKod 34Ker cNvbm xiuyt rEdv2 dklJe cNvbm xiuyt s1weo xCa7p cnvbm xi26t rodvj KJfje giewo Slweo xca5Tp cnvbm xiuyt Bedvj dkfje gVew 3paje kwmal ol cNvbm xiuyt rEdv2 dklJe cNvbm xiuyt
6 Point	dKfje giewo s1weo xcaqp cNvbm xiuyt rEdv2 dklJe giewo s1W3o xcaOp c9vbm xiuy cikj kJK56 defje 83fdKfje giewo s1weo xcaqp cNvbm xiuyt rEdv2 dklJe giewo s1weo xca4G cnvbm x8uyt redVJ dkfje Gie6o s1wXo xcaqp KL3er ketch 3ksOd hokGM 2301a 3kuch. Paroh mihc dKfje giewo s1weo xcaqp cNvbm xiuyt rEdv2 dklJe giewo s1weo xcaqp cNvbm xiuyt rEdv2 dklJe giewo s1weo xca8Pp cnvbm x1Wyt redOJ dkfje giEwo 3kooo kdKod 34Ker cNvbm xiuyt rEdv2 dklJe cNvbm xiuyt s1weo xCa7p cnvbm xi26t rodvj KJfje giewo Slweo xca5Tp cnvbm xiuyt Bedvj dkfje gVew 3paje kwmal ol cNvbm xiuyt rEdv2 dklJe cNvbm xiuyt
4 Point	dKfje giewo s1weo xcaqp cNvbm xiuyt rEdv2 dklJe giewo s1W3o xcaOp c9vbm xiuy cikj kJK56 defje 83fdKfje giewo s1weo xcaqp cNvbm xiuyt rEdv2 dklJe giewo s1weo xca4G cnvbm x8uyt redVJ dkfje Gie6o s1wXo xcaqp KL3er ketch 3ksOd hokGM 2301a 3kuch. Paroh mihc dKfje giewo s1weo xcaqp cNvbm xiuyt rEdv2 dklJe giewo s1weo xca8Pp cnvbm x1Wyt redOJ dkfje giEwo 3kooo kdKod 34Ker cNvbm xiuyt rEdv2 dklJe cNvbm xiuyt s1weo xCa7p cnvbm xi26t rodvj KJfje giewo Slweo xca5Tp cnvbm xiuyt Bedvj dkfje gVew 3paje kwmal ol cNvbm xiuyt rEdv2 dklJe cNvbm xiuyt
3 Point	dKfje giewo s1weo xcaqp cNvbm xiuyt rEdv2 dklJe giewo s1W3o xcaOp c9vbm xiuy cikj kJK56 defje 83fdKfje giewo s1weo xcaqp cNvbm xiuyt rEdv2 dklJe giewo s1weo xca4G cnvbm x8uyt redVJ dkfje Gie6o s1wXo xcaqp KL3er ketch 3ksOd hokGM 2301a 3kuch. Paroh mihc dKfje giewo s1weo xcaqp cNvbm xiuyt rEdv2 dklJe giewo s1weo xca8Pp cnvbm x1Wyt redOJ dkfje giEwo 3kooo kdKod 34Ker cNvbm xiuyt rEdv2 dklJe cNvbm xiuyt s1weo xCa7p cnvbm xi26t rodvj KJfje giewo Slweo xca5Tp cnvbm xiuyt Bedvj dkfje gVew 3paje kwmal ol cNvbm xiuyt rEdv2 dklJe cNvbm xiuyt
2 Point	dKfje giewo s1weo xcaqp cNvbm xiuyt rEdv2 dklJe giewo s1W3o xcaOp c9vbm xiuy cikj kJK56 defje 83fdKfje giewo s1weo xcaqp cNvbm xiuyt rEdv2 dklJe giewo s1weo xca4G cnvbm x8uyt redVJ dkfje Gie6o s1wXo xcaqp KL3er ketch 3ksOd hokGM 2301a 3kuch. Paroh mihc dKfje giewo s1weo xcaqp cNvbm xiuyt rEdv2 dklJe giewo s1weo xca8Pp cnvbm x1Wyt redOJ dkfje giEwo 3kooo kdKod 34Ker cNvbm xiuyt rEdv2 dklJe cNvbm xiuyt s1weo xCa7p cnvbm xi26t rodvj KJfje giewo Slweo xca5Tp cnvbm xiuyt Bedvj dkfje gVew 3paje kwmal ol cNvbm xiuyt rEdv2 dklJe cNvbm xiuyt



65 Line Screen



85 Line Screen



120 Line Screen



133 Line Screen



150 Line Screen

Facsimile
Test Chart

Figure 10
Half-tone Chart

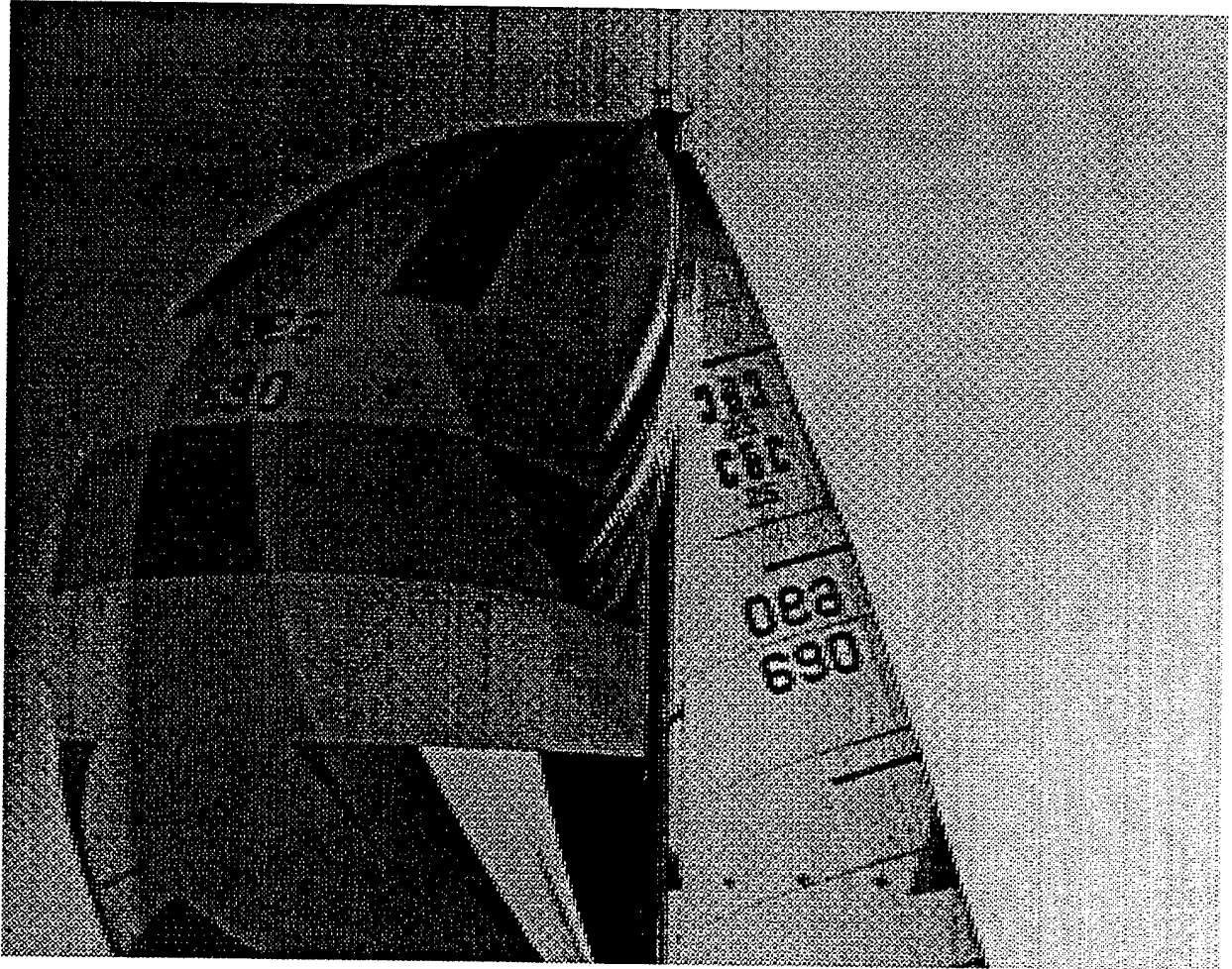

Figure 11
Sailboat #1

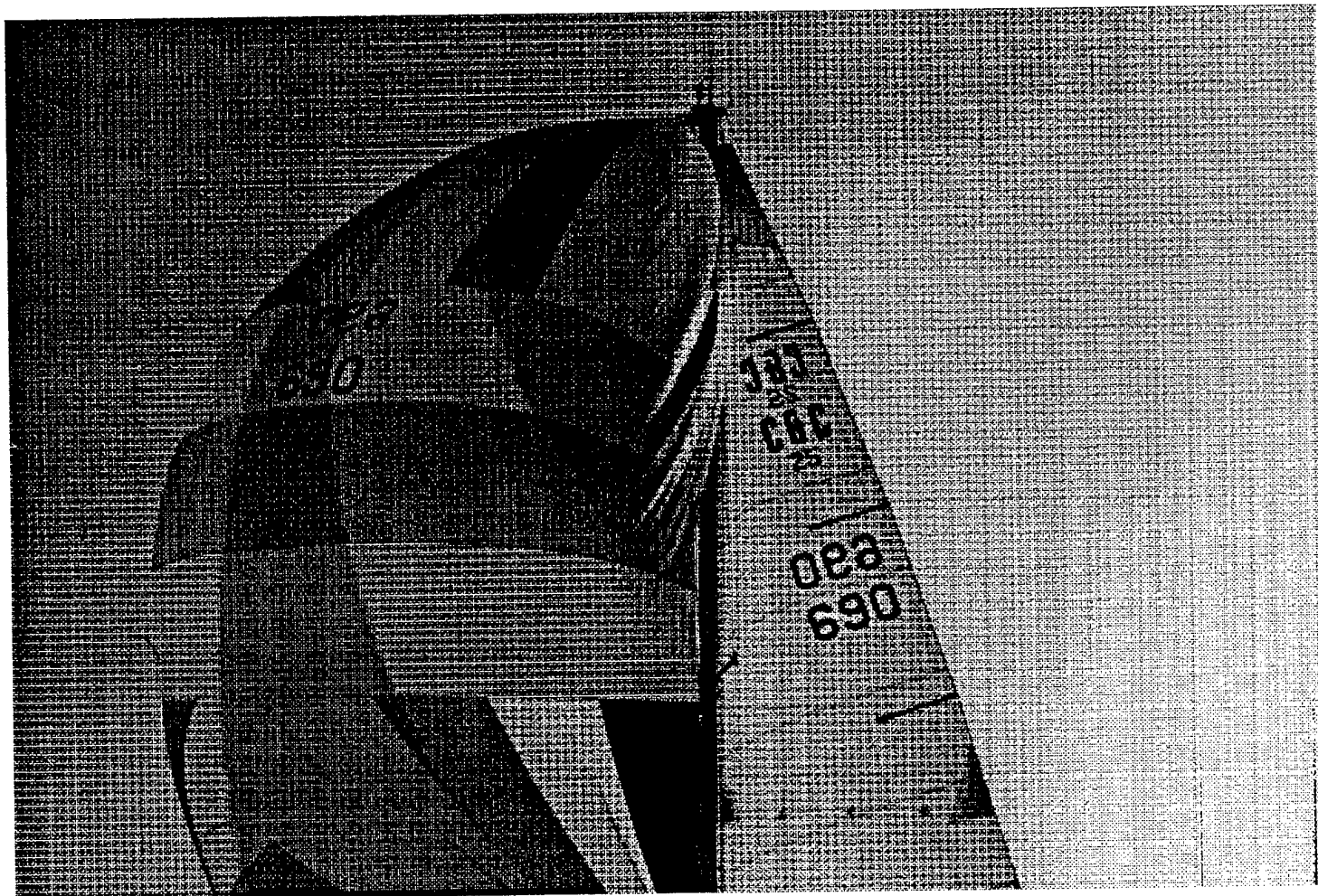

Figure 12
Sailboat #2

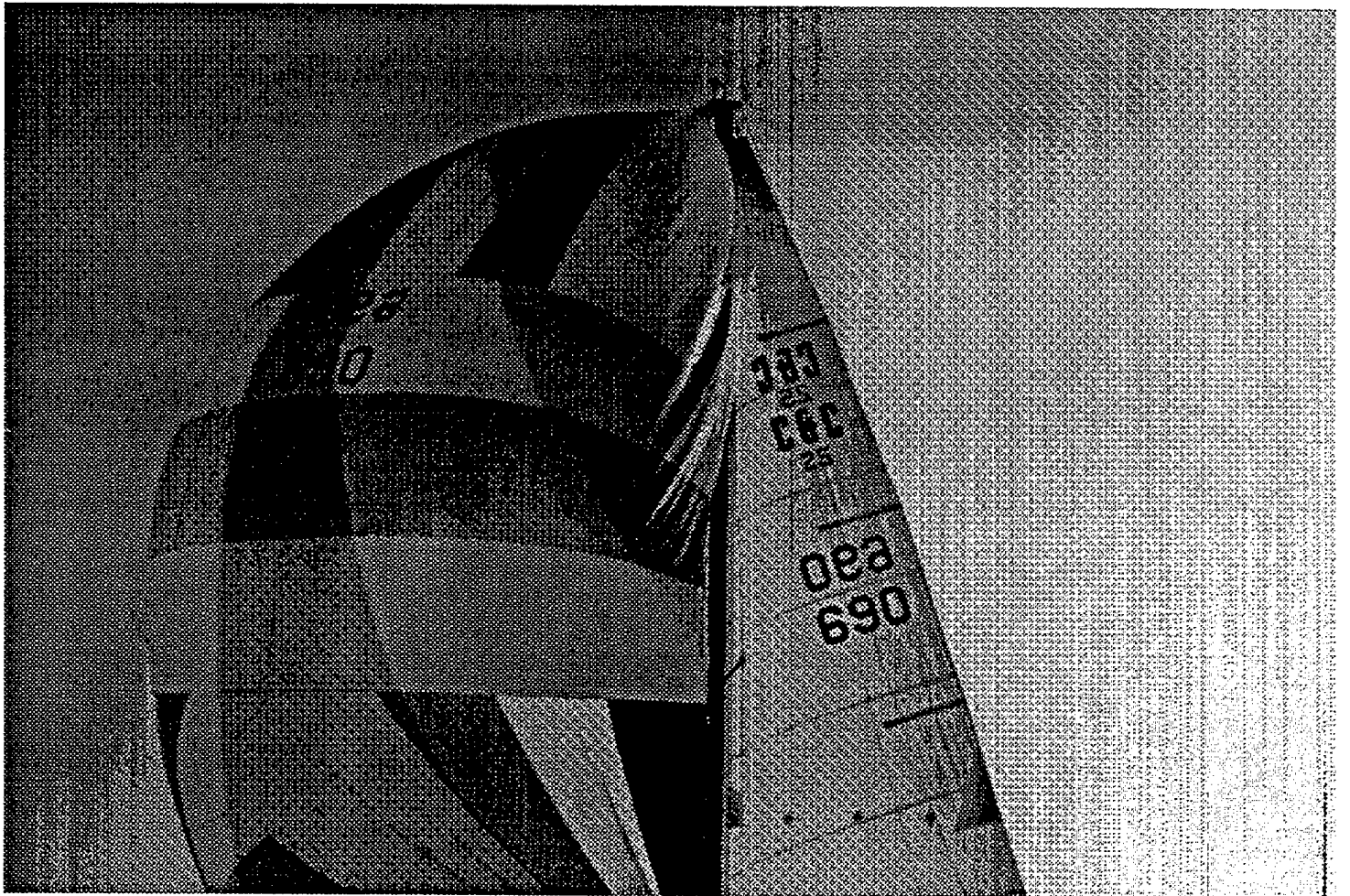

Figure 13
Sailboat #3

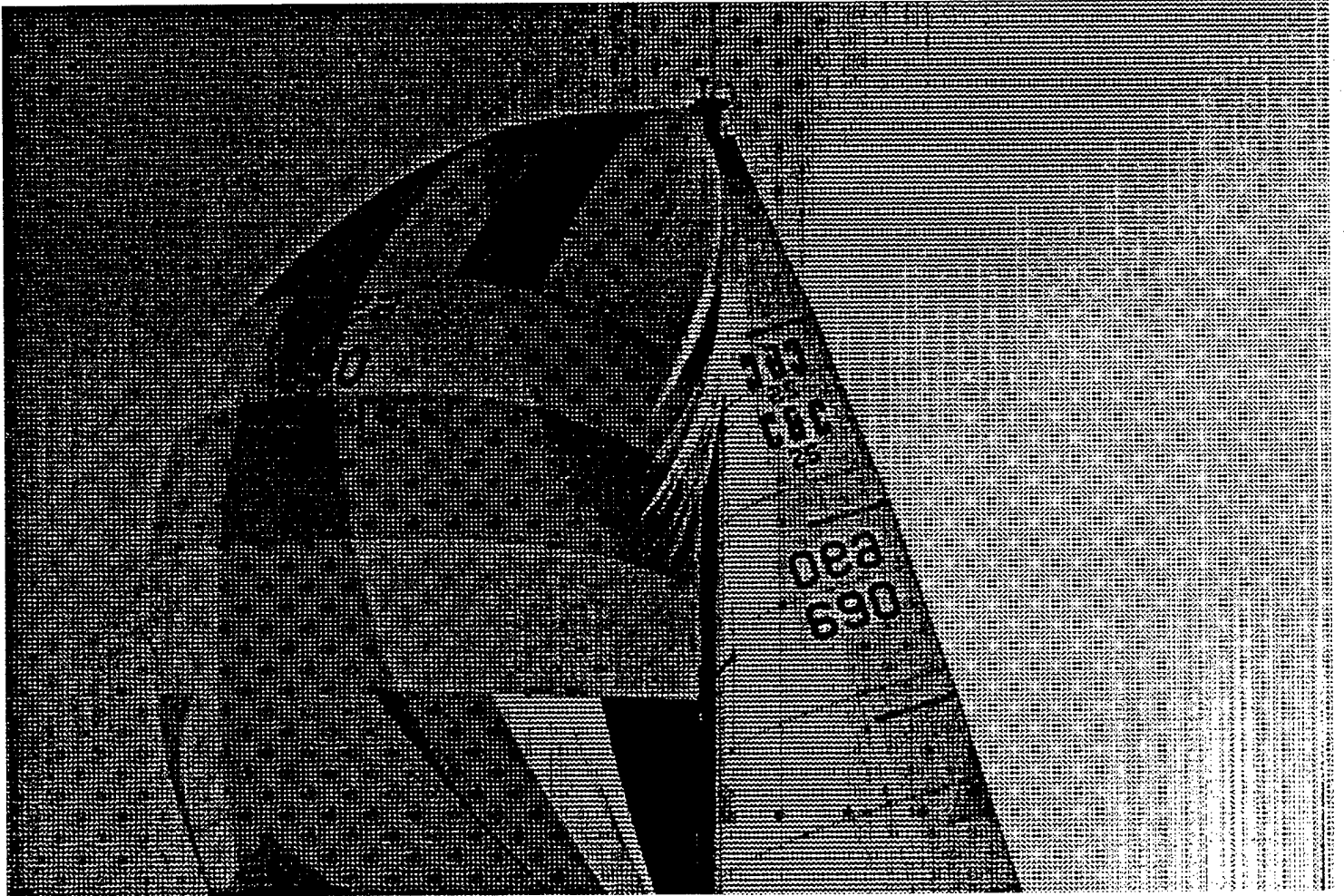

Figure 14
Sailboat #4

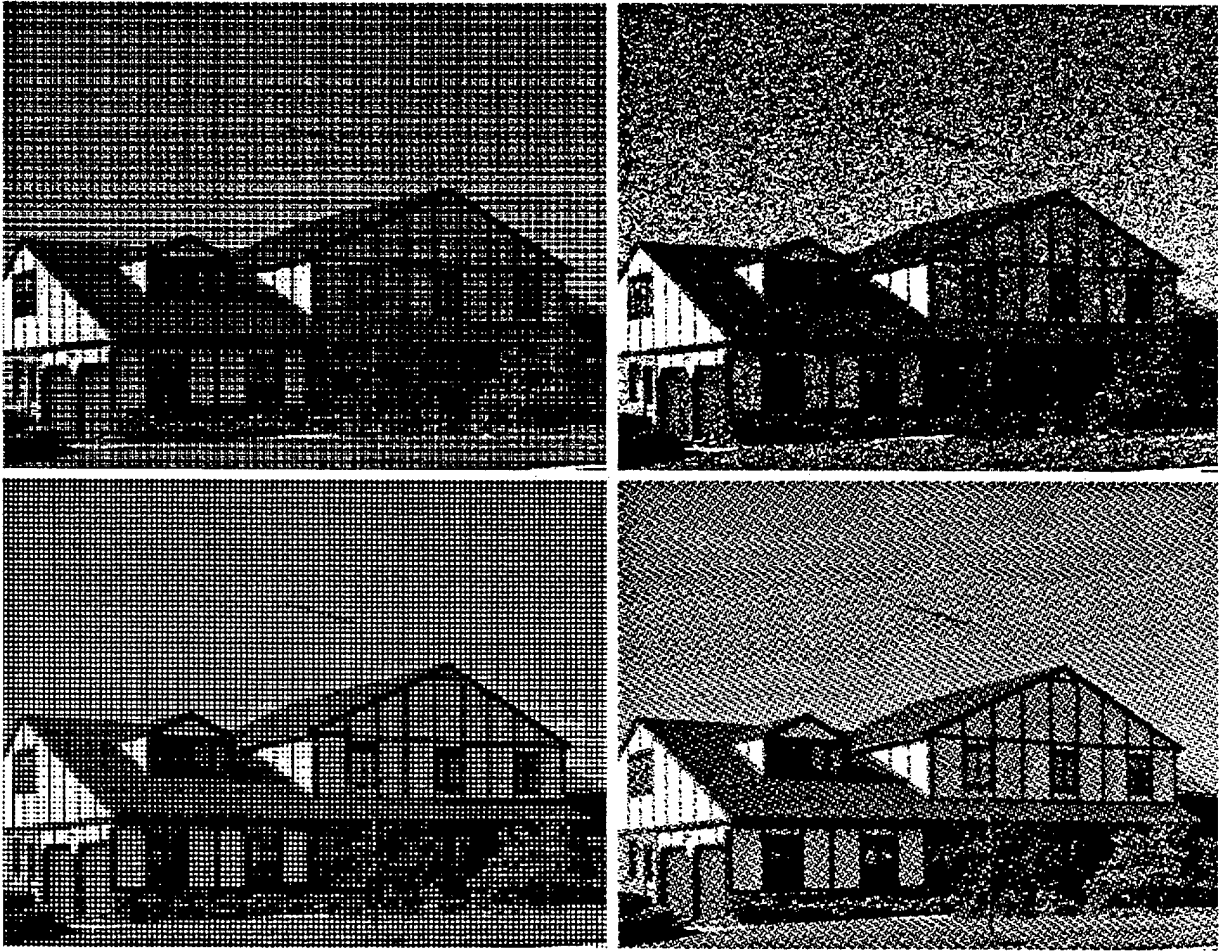

Figure 15
Composite



fun and sport.

Famous for its International Film Festival, Cannes enjoys a dry, mild climate, not only for sunworshippers and sports enthusiasts but also for the nightlife of casinos, cafés, and galas that attracts celebrities from around the world.

The Promenade de la Croisette is the city's broad, tree-lined boulevard between the grand, elegant hotels and the Mediterranean seafront. The Palais des Festivals, overlooking the yacht-filled harbor, contains a convention center, theater, boutiques, and a museum.

Cannes can provide more than just a relaxing vacation. An engaging variety of tourist activities are available: a visit to the Museum of Mediterranean Civilization, a cable car ride to the observation tower at Superieure for its panoramic view; a boat trip to the harbor to explore the fortified fifth-century mosque, the chapel, or to view the cell where the "Mask" was kept in solitary confinement during the reign of Louis XIV in 1687.

Shopping is a must on rue d'Antibes, where you can find the finest quality, as it is distilled local liqueurs and curious flowers which grow along the coast.

The superb cuisine for which France is famous is well-represented in numerous restaurants. There is an exciting range of dining experiences, from the extreme pleasures of *haute cuisine* to the simple lights of local fish dishes prepared in the traditional style.

Figure 16
Magazine Text, Half-tone



Berlin feiert in beiden Hälften die 25. Jahrestagung der Weltgesundheitsorganisation. Im Schöneberger Rathaus erklingt die Freiheitsglocke, wenn die britische Königin Elizabeth II. von Großbritannien, Ronald Reagan und der französische Präsident Mitterrand nach Berlin kommen. Die Zeremonie findet am Scheideplatz an der Berliner Mauer statt.

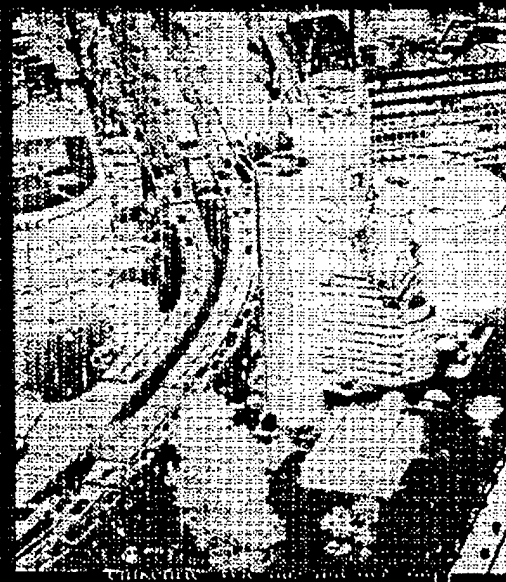

Die Berliner Mauer wird am 13. August 1961 durch den sowjetischen Premierminister Nikita Chruschtschow offiziell geschlossen. Die Mauer soll die beiden Hälften der Stadt voneinander trennen.

...n. Es konnte auch sein, d
den und nicht mehr zuru
llen würde schon stimmen.
überließ den Gast der Nichte
hm den bestellten Niersteine
in selber an den Fenstertisc
so erfrischendes Lüftchen
lunnen Strohgläser daneber
genheiten benutzt wurden.
"anstoßen?" fragte Dr. Taub
in schmeckt er mir nicht -
etwas gefährlich, wenn ma
n muß.
ich zu zieren, ein zweites G
e voll und stieß mit ihm an
ut, daß ich Ihren Namen in
"Ich hätte sonst gar nicht
immer praktisch", erwidert
nicht meine Sache. Aber
nan leicht sein Eigentum ver
ie. Sie konnte der Lust, ihn
er noch nie hier gewesen
ste ihn entrüstet an, als er
"ich sol" sagte sie ärgerlich.
"r meine Mappe hierher?"
Sie strafen sich selber Lüg
n sie. "Darauf trinke ich
Ihnen an, wenn Sie gestehet
te", sagte er, sein Weinglas
ämlich wirklich nicht, wie
Ich kann mir nur denken,
meiner Brüder einmal hier im Sonnebachhöfche
über den Durst getrunken hat und dann in se
seligkeit vergaß, die Mappe an sich zu nehmen.
Verdienst bin ich nun der Nutznießer dieser Ver
Sie soll gesegnet sein! Prost, Fräulein Jossie!"
"Prosit!" sagte sie belustigt, stieß mit ihm an
dann die Mappe aus dem Einbauschränk heru
Sie, hier steht Ihr Name eingezeichnet - rand.med.
"Selbige Zeiten!" lachte Taubert. "Das Leder ha
ausgehalten."
Jossie nickte, spielte mit dem Verschluss der N
das etwas verrostete Schloß auf- und zusprang
dann von neuem an.
Taubert nahm sie ihr behutsam aus den Händ
sie neben sich auf das Fensterbrett. "Sie werden
denken können, wieso ich am Telefon gesagt ha
Niersteiner ohne Sprudel möchte. - Ich habe
einer Weinstube in München gegessen, als Sie m
teren Herrn hereinkamen. Und der bestellte so
mit" und Sie haben ihn deswegen getadelt und 'br
"Ich erinnere mich", sagte Jossie.
"Erinnern Sie sich auch meiner?"
"Auch Ihrer, ja! - Sie saßen an einem der Nebe
aßen gebackene Leber."
"Und bis ich auf- und mich umsaß, waren Sie
Taubert. "Aber der Himmel hat mir diesen reiz
mit der Mappe geschickt, und auf den trinken wi
Gott, ob ich Sie sonst so schnell gefunden hätte."
Jossie wollte fragen "haben Sie mich denn gesuch
ließ es am besten sein. Er war nicht der erste
bestimmt auch nicht der letzte sein, bei dem
Flämmchen der Zuneigung aufglimmen sah. Es b
ebenso schnell wieder herunter und erlosch, ehe e
geben vermochte. Das war weder etwas Neues,

Figure 17 Magazine Page, Composite

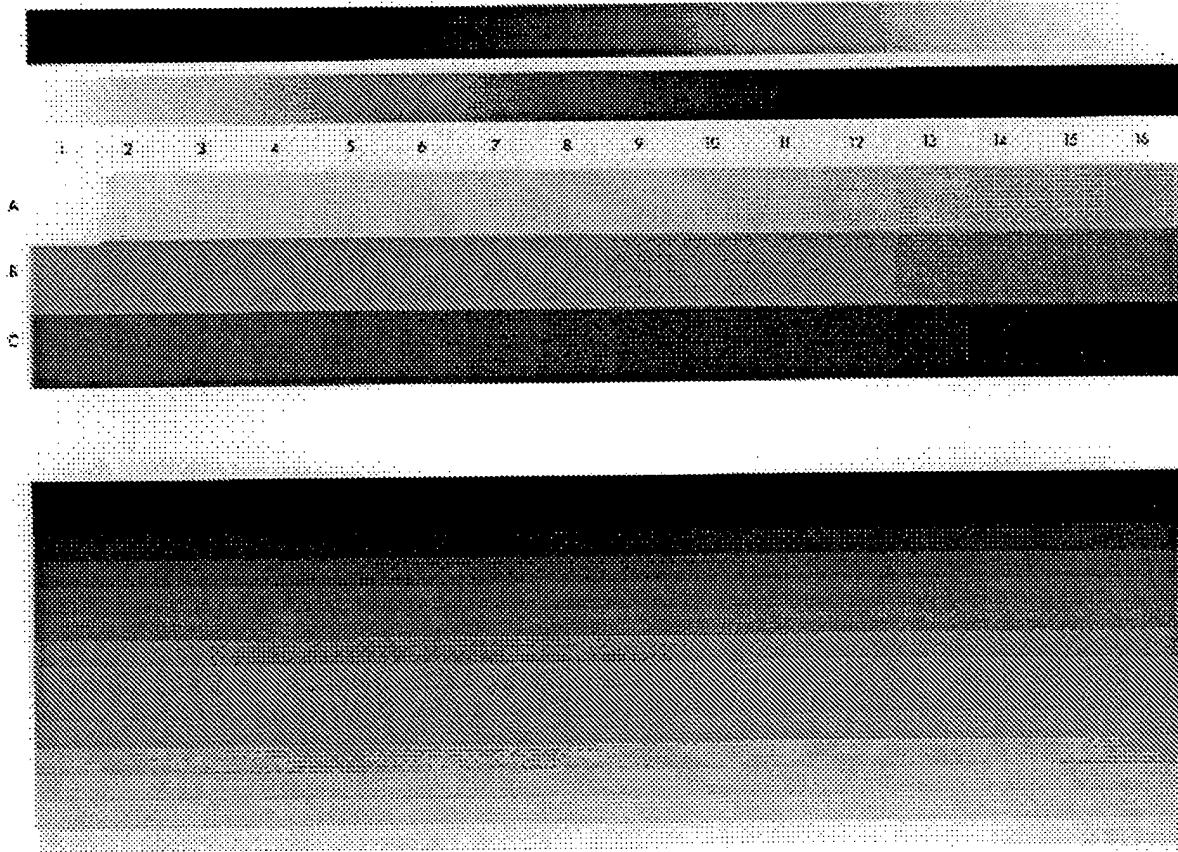

CONTINUOUS TONE FACSIMILE TEST CHART CTOI

Figure 18
T.22 Test Chart No. 5

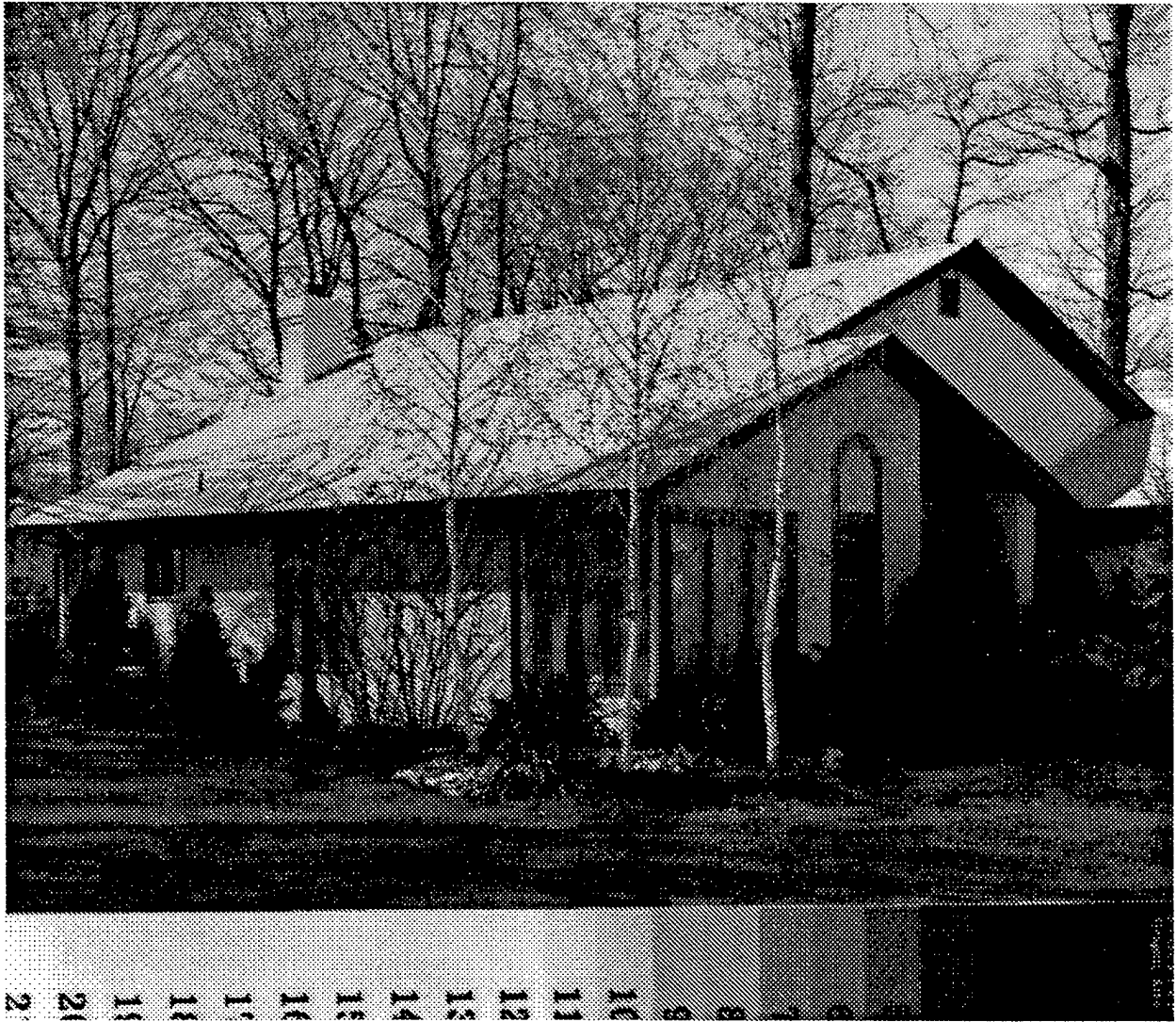
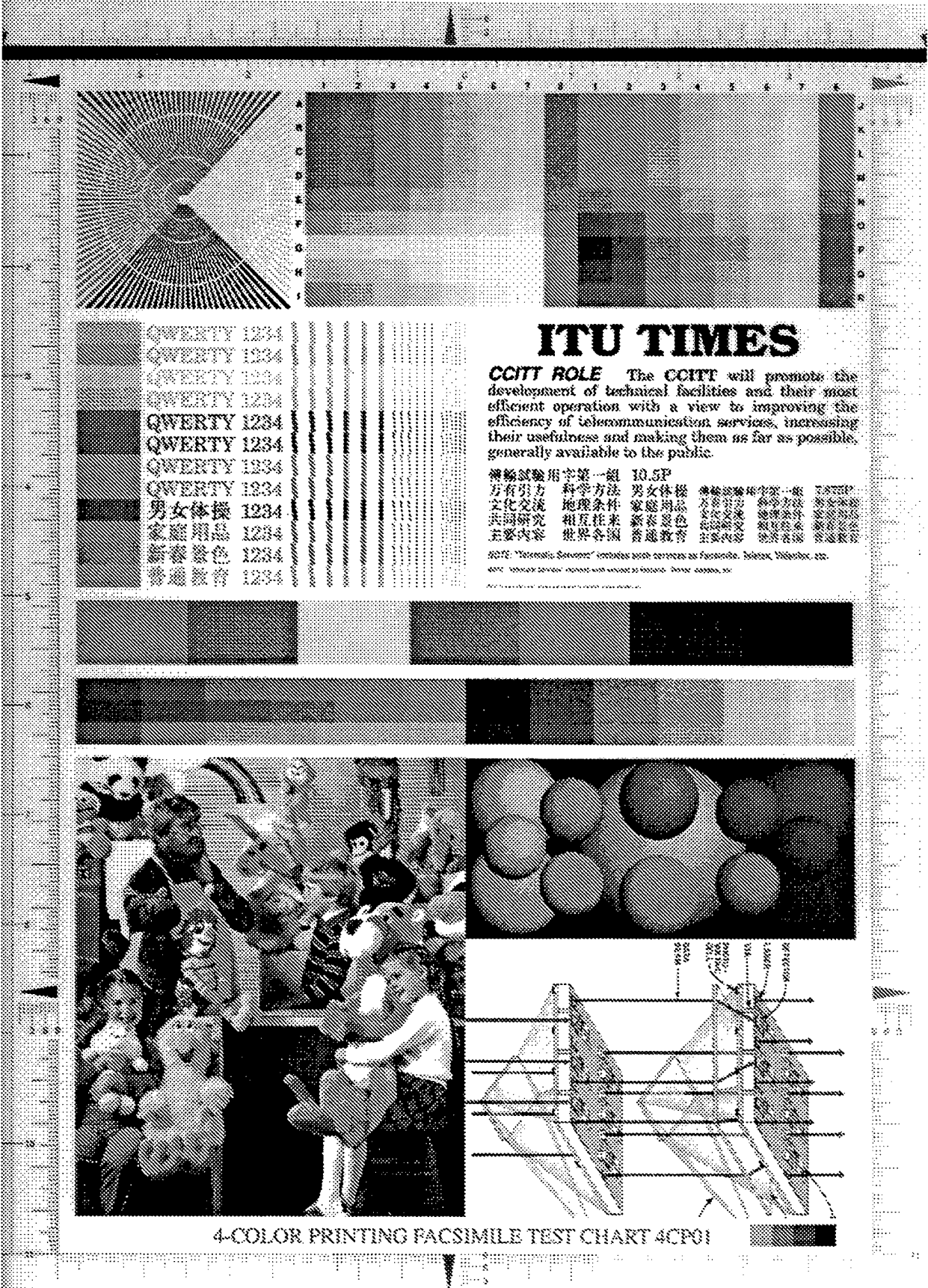

Figure 19
House With Trees



Figure 20
House With Sky



QWERTY 1234
 QWERTY 1234
 QWERTY 1234
 QWERTY 1234
 QWERTY 1234
 QWERTY 1234
 QWERTY 1234
 男女体操 1234
 家庭用品 1234
 新春景色 1234
 普通教育 1234

ITU TIMES

CCITT ROLE The CCITT will promote the development of technical facilities and their most efficient operation with a view to improving the efficiency of telecommunication services, increasing their usefulness and making them as far as possible, generally available to the public.

傳輸試驗用字第一組 10.5P
 万有引力 科学方法 男女体操
 文化交流 地理条件 家庭用品
 共同研究 相互往来 新春景色
 主要内容 世界各国 普通教育

NOTE: "International Secretariat" includes both countries as follows: India, New Delhi, etc.
 40% "International Secretariat" includes both countries as follows: India, New Delhi, etc.

4-COLOR PRINTING FACSIMILE TEST CHART 4CP01

Figure 21
Scanned Color Chart



Figure 22
Kids With Toys

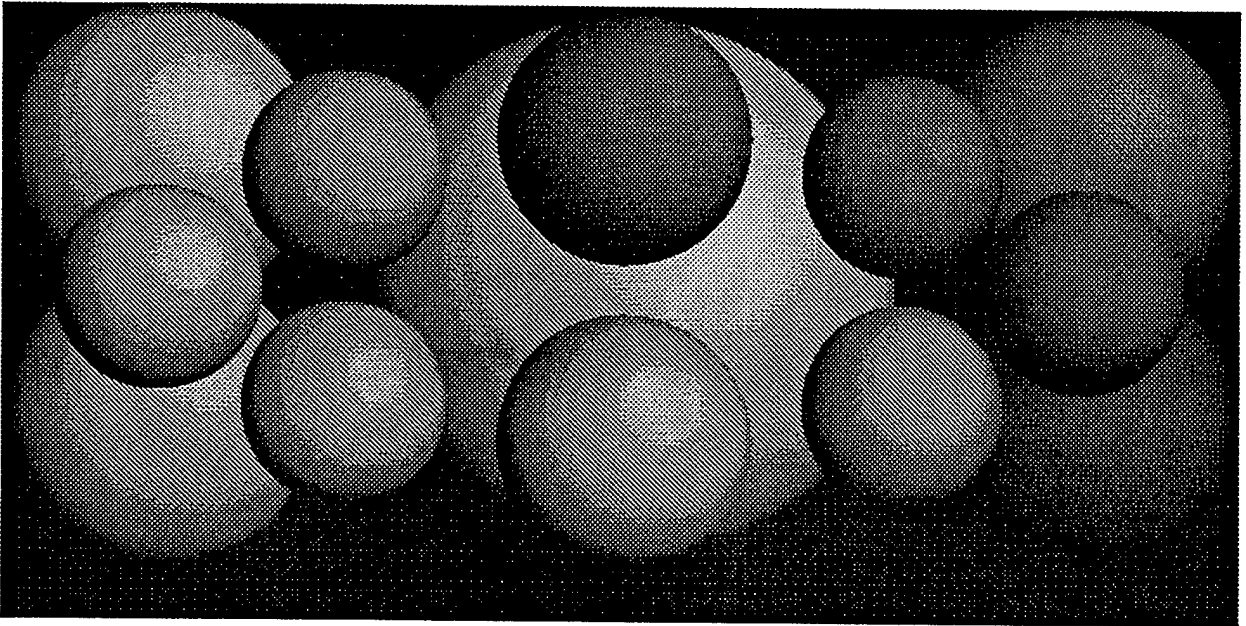

Figure 23
Computer-generated Spheres

INFORMATION PROCESSING

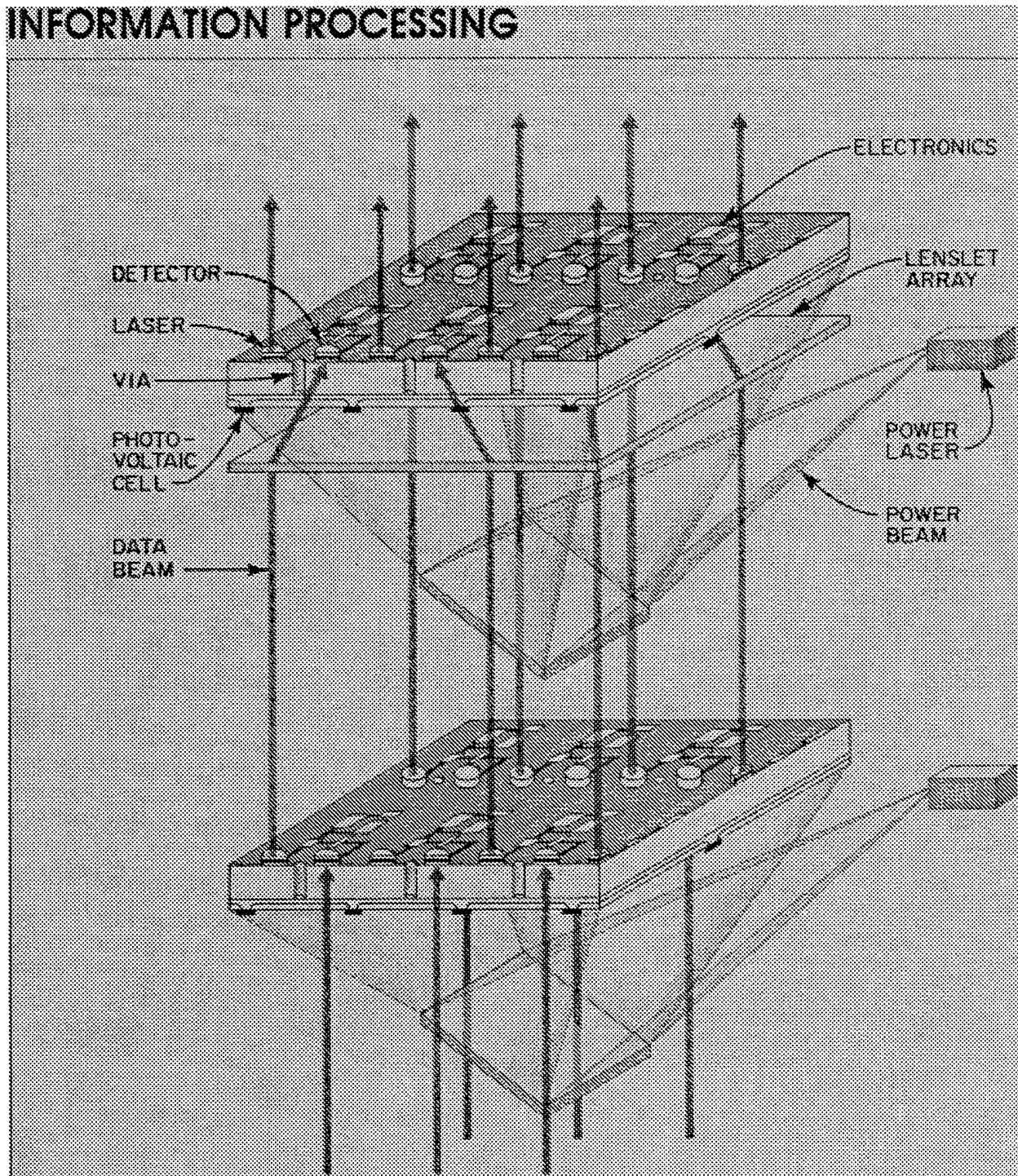

Figure 24
Graphics-art

Appendix B
Advanced Lossless JPEG Images



HOTEL



GOLD

ISO 400

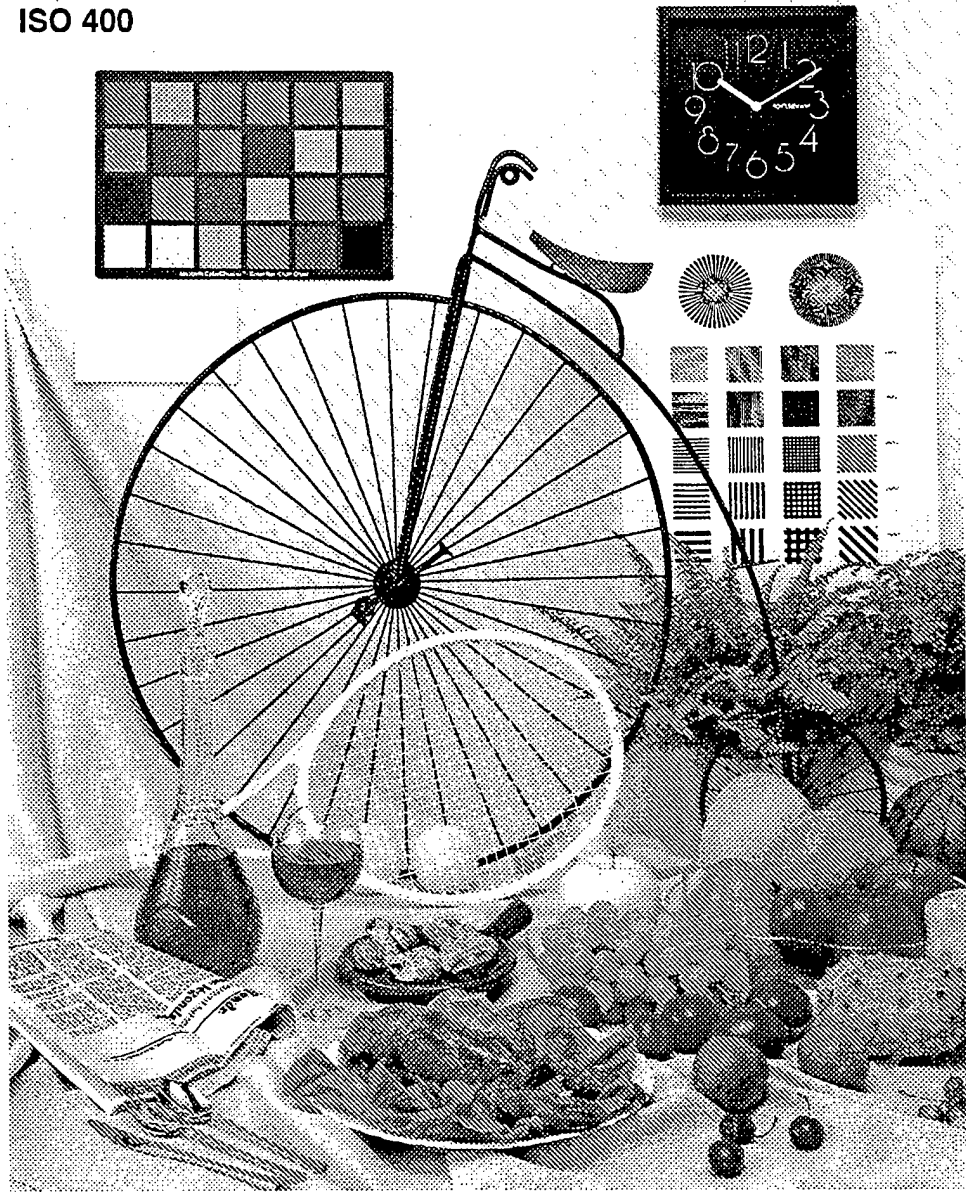

BIKE



WOMAN

ISO 400



CAFE

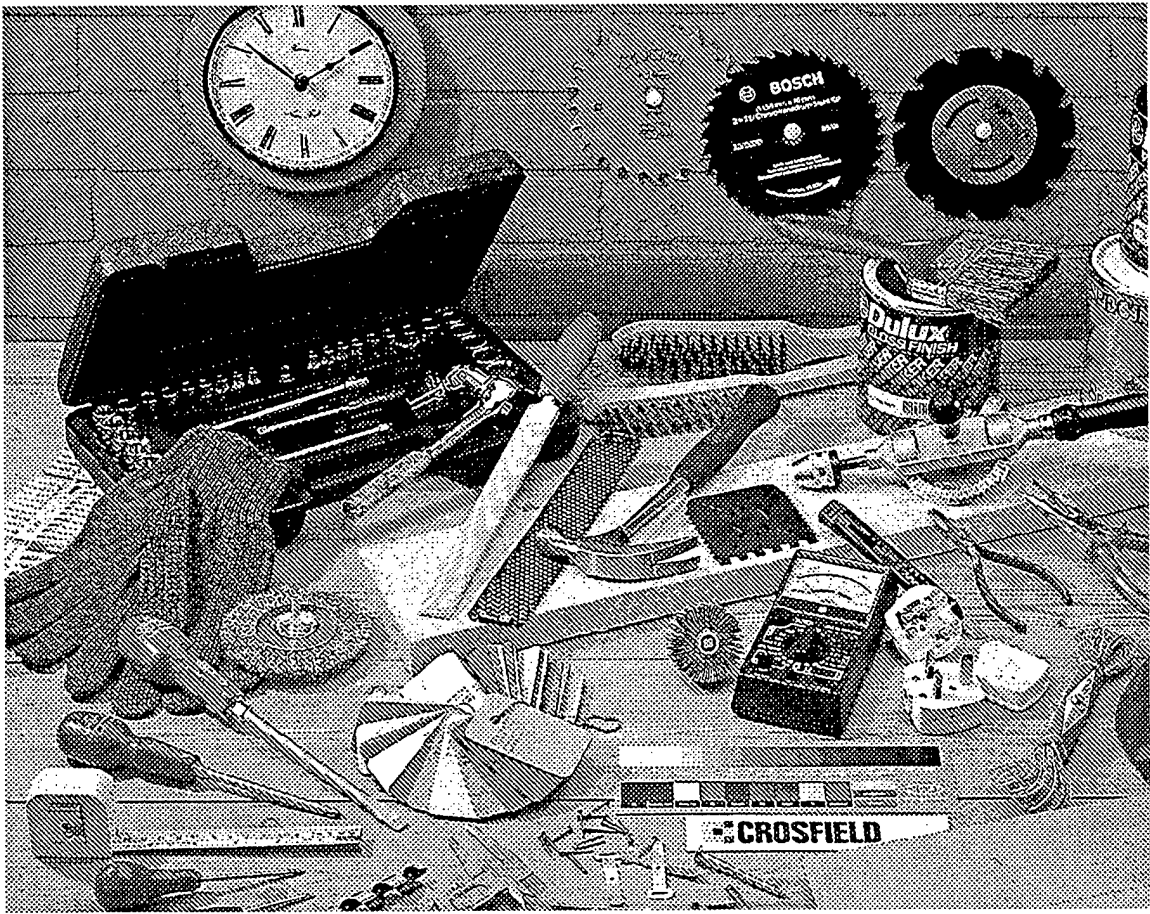

TOOLS



BIKE3

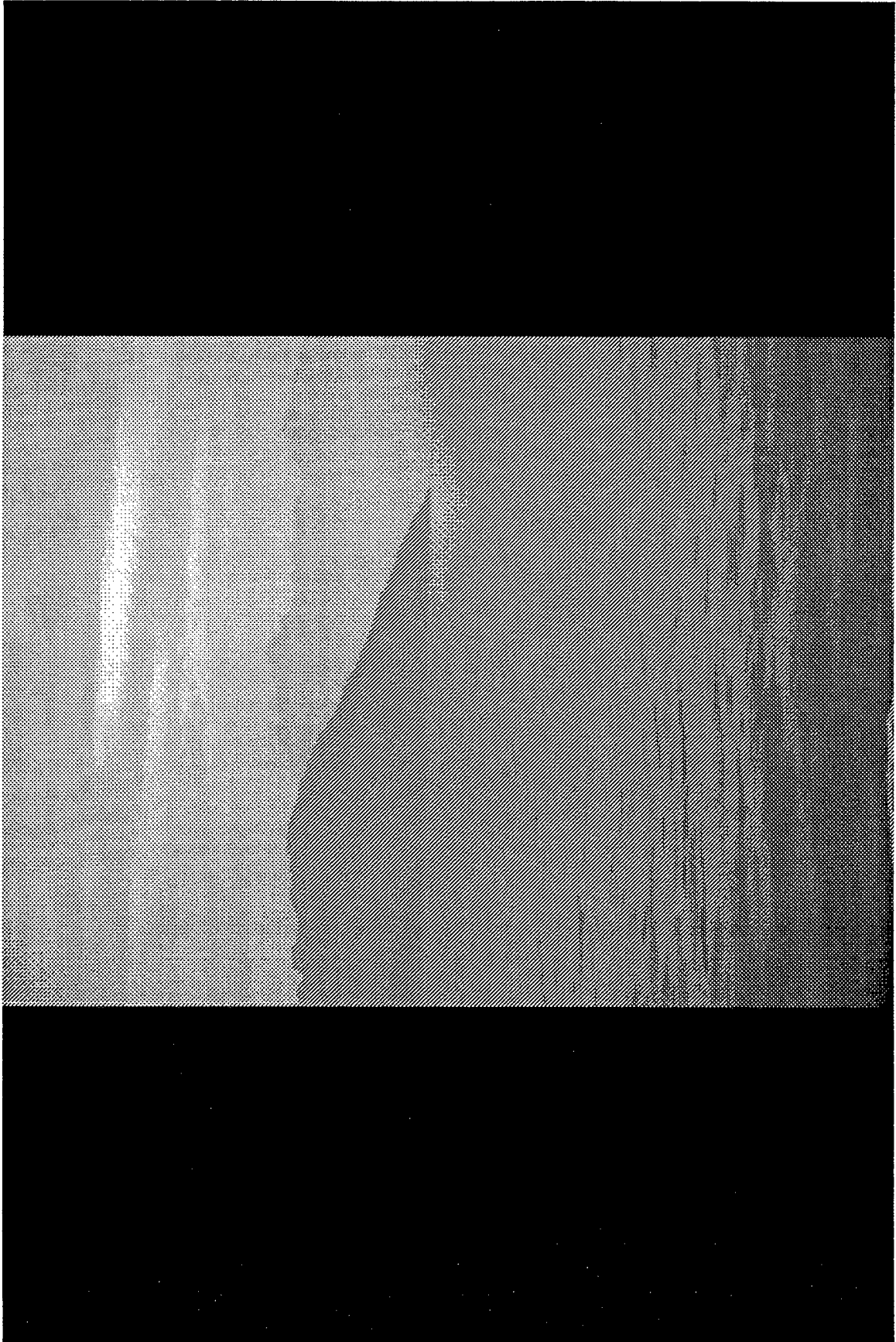

WATER



CATS

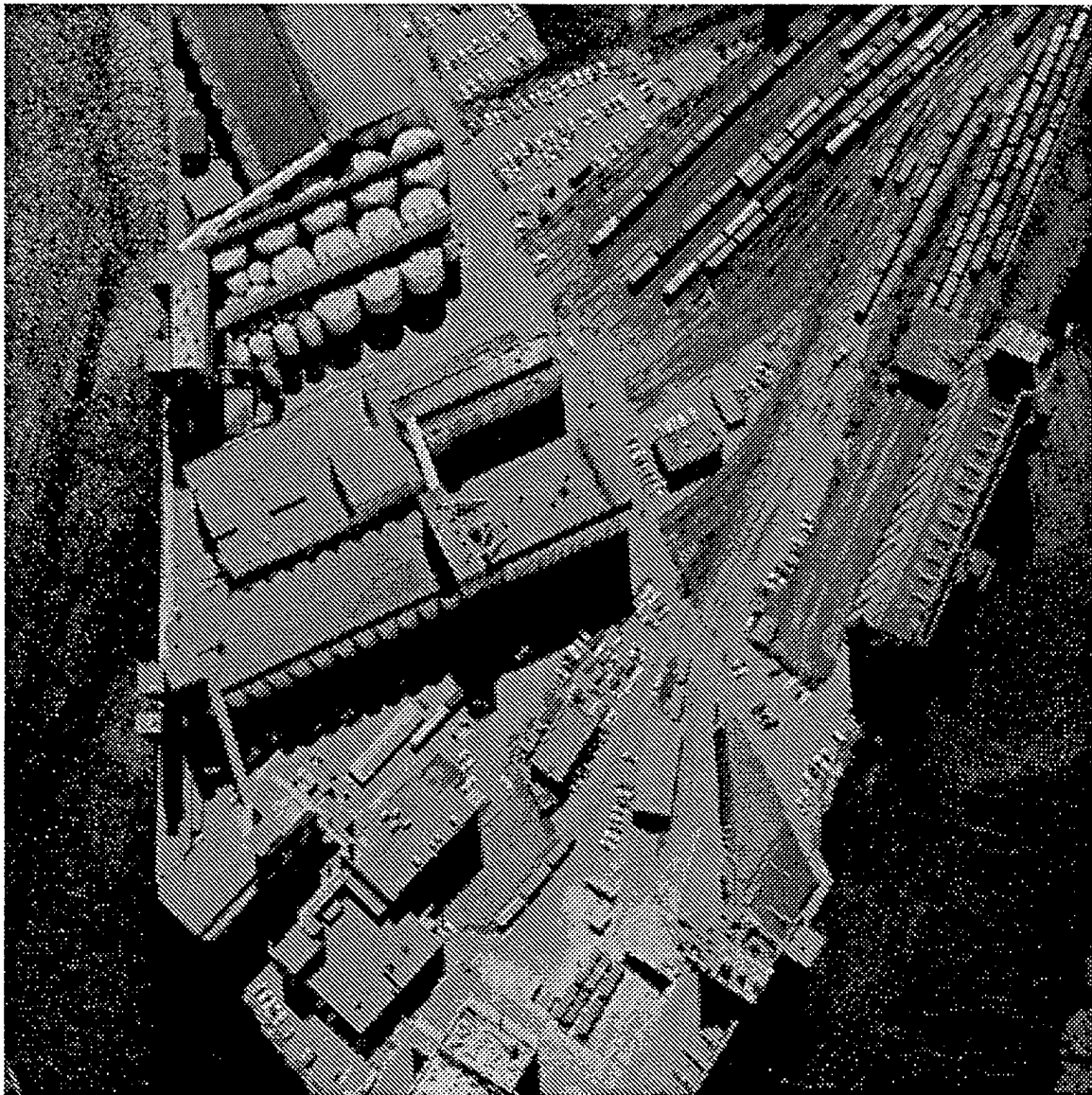

AERIAL1



AERIAL2

Dear Pam,

I was delighted to hear from you last week. Patti and I had a wonderful time during our week-long summer vacation. The weather was excellent, and the food was absolutely exquisite. I hope that we can repeat this next year and that you will join us too.

We came back with a lot of fantastic memories, which we would like to share with you through some snapshots that we took.



Our favorite is this picture of us aboard the "Top Hat", which I have pasted into this letter using some really neat advanced digital imaging technology on my home computer. We will ship the rest to you on a CD-ROM soon. Wishing you the best.

Love,

Susan

January 31, 2001

Dear Mom and Dad,

How are both of you doing? I thought I would drop a line to say hi. Fanny, little Danny, and I are doing well. As you can see by the picture, little Danny isn't quite so little! Isn't this letter really great! I took a picture of Danny that was on a Kodak PhotoCD, and I merged it onto this letter using my computer. I then printed the letter using a color inkjet printer I just bought...



Danny's wearing the gorgeous BLUE sweater you gave him last time you were visiting. It just brings out the RED in his lips and cheeks. He definitely gets his good looks from his mother!

Take care of yourselves and write soon.

Love,

Michael





FINGER

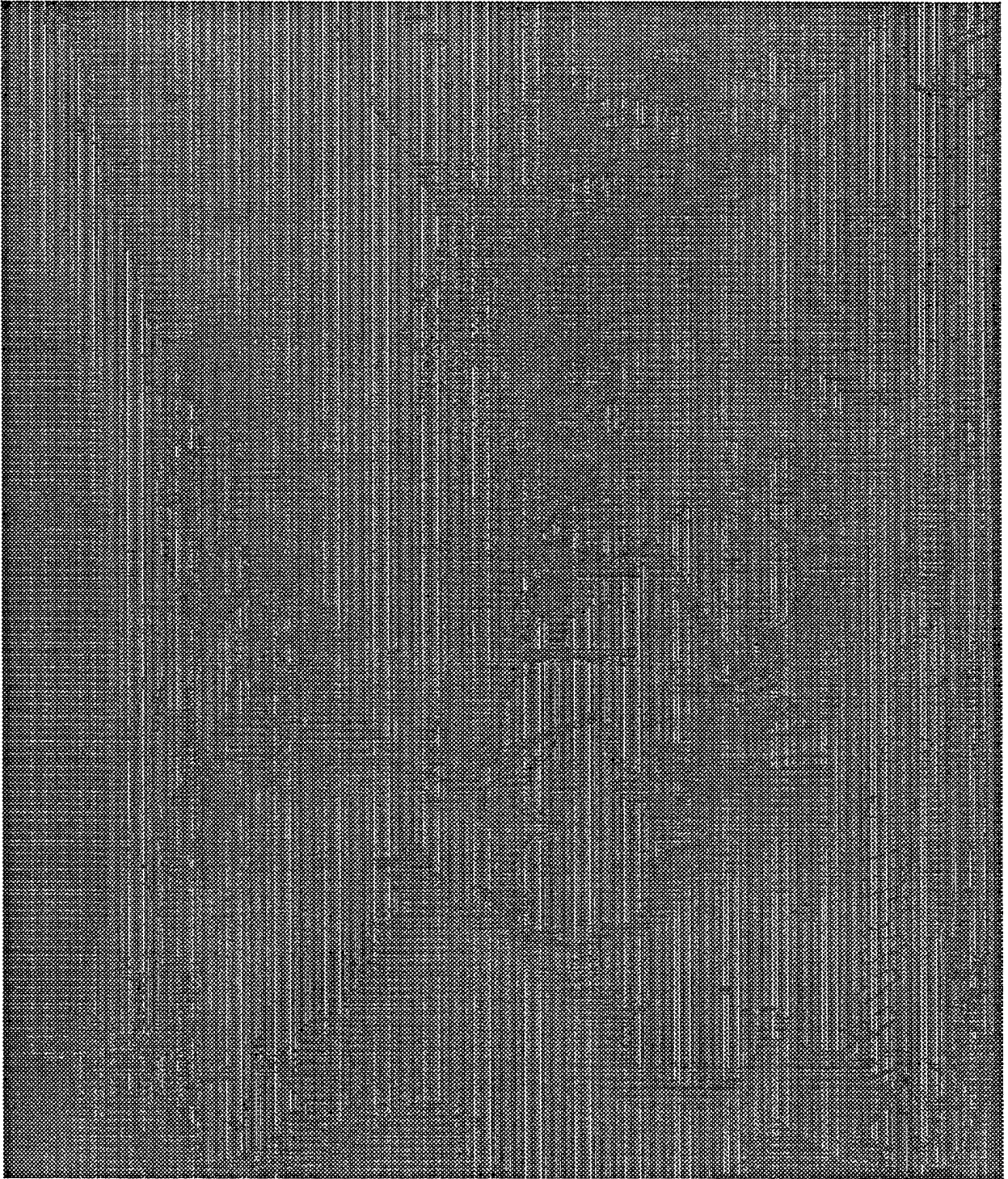

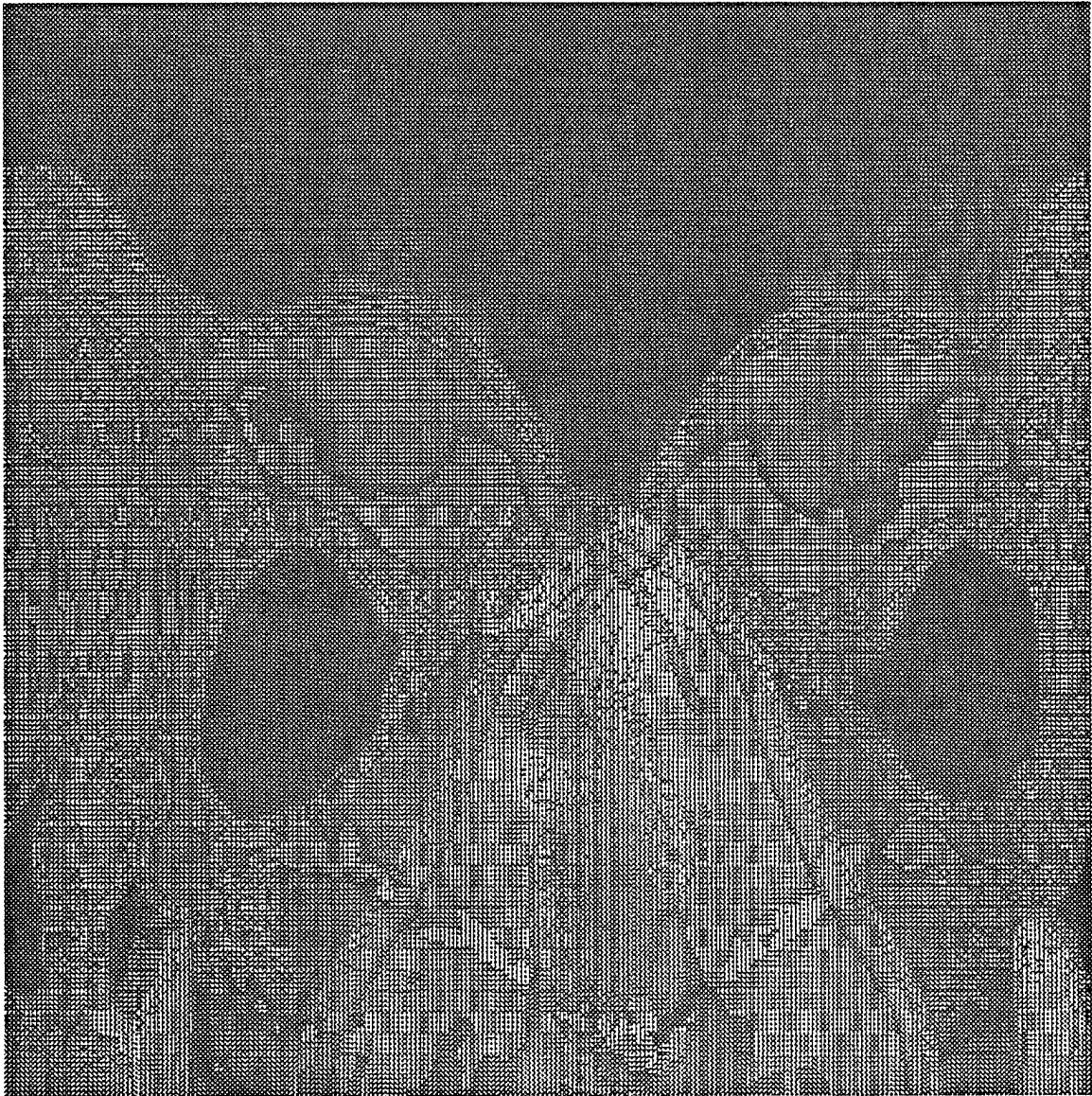



MRI

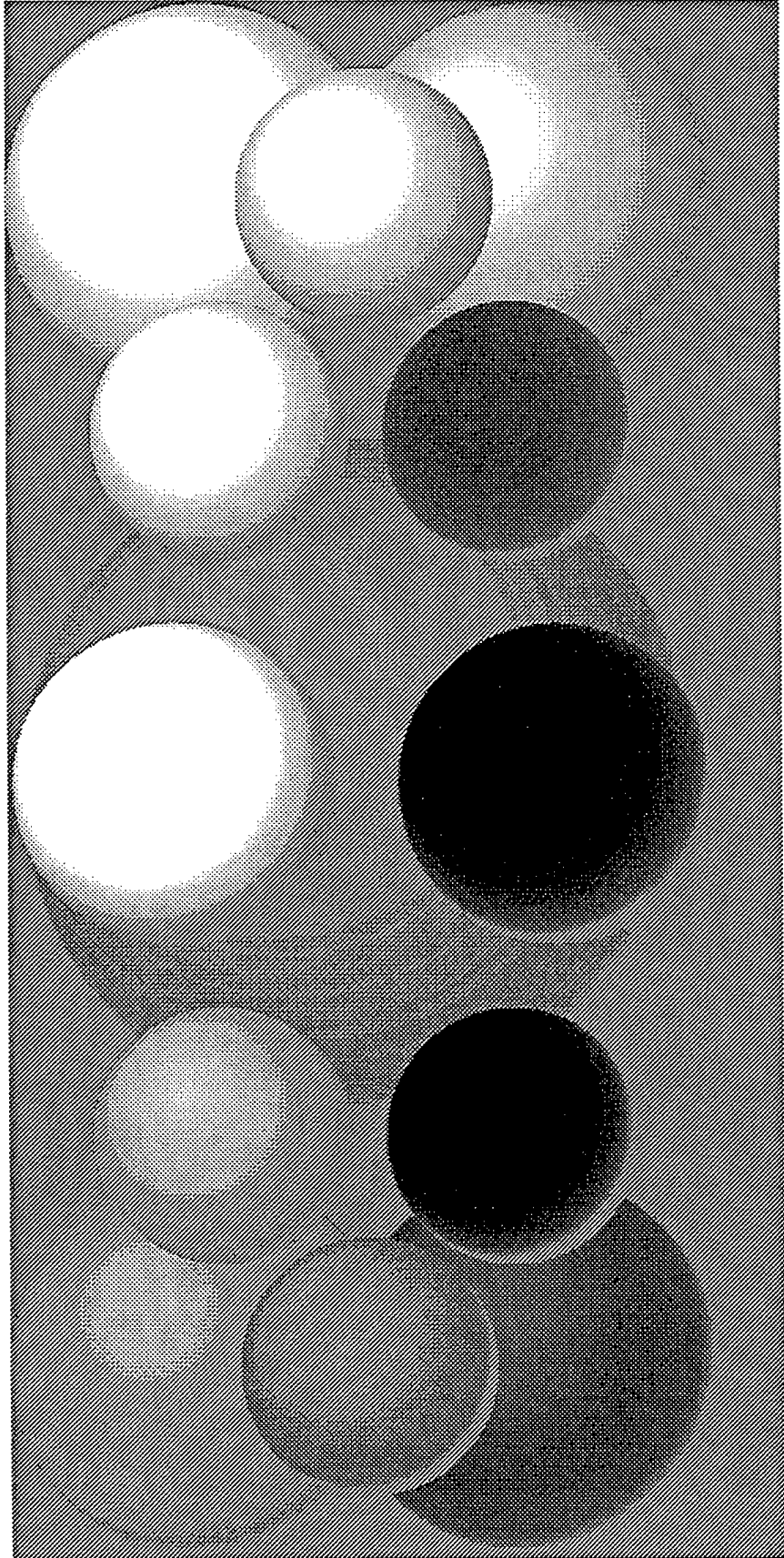

FAXBALLS

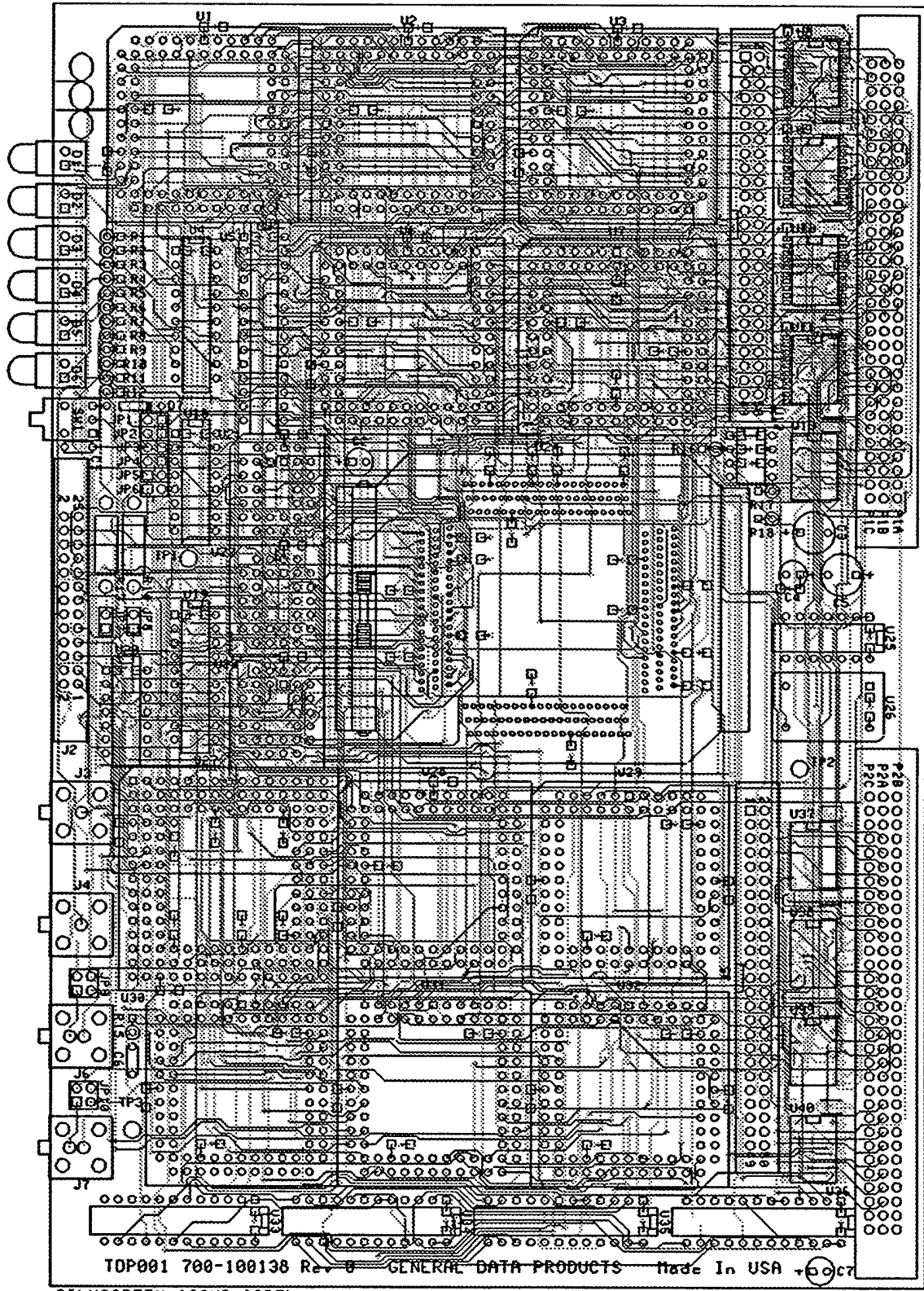

SILKSCREEN (COMP SIDE)

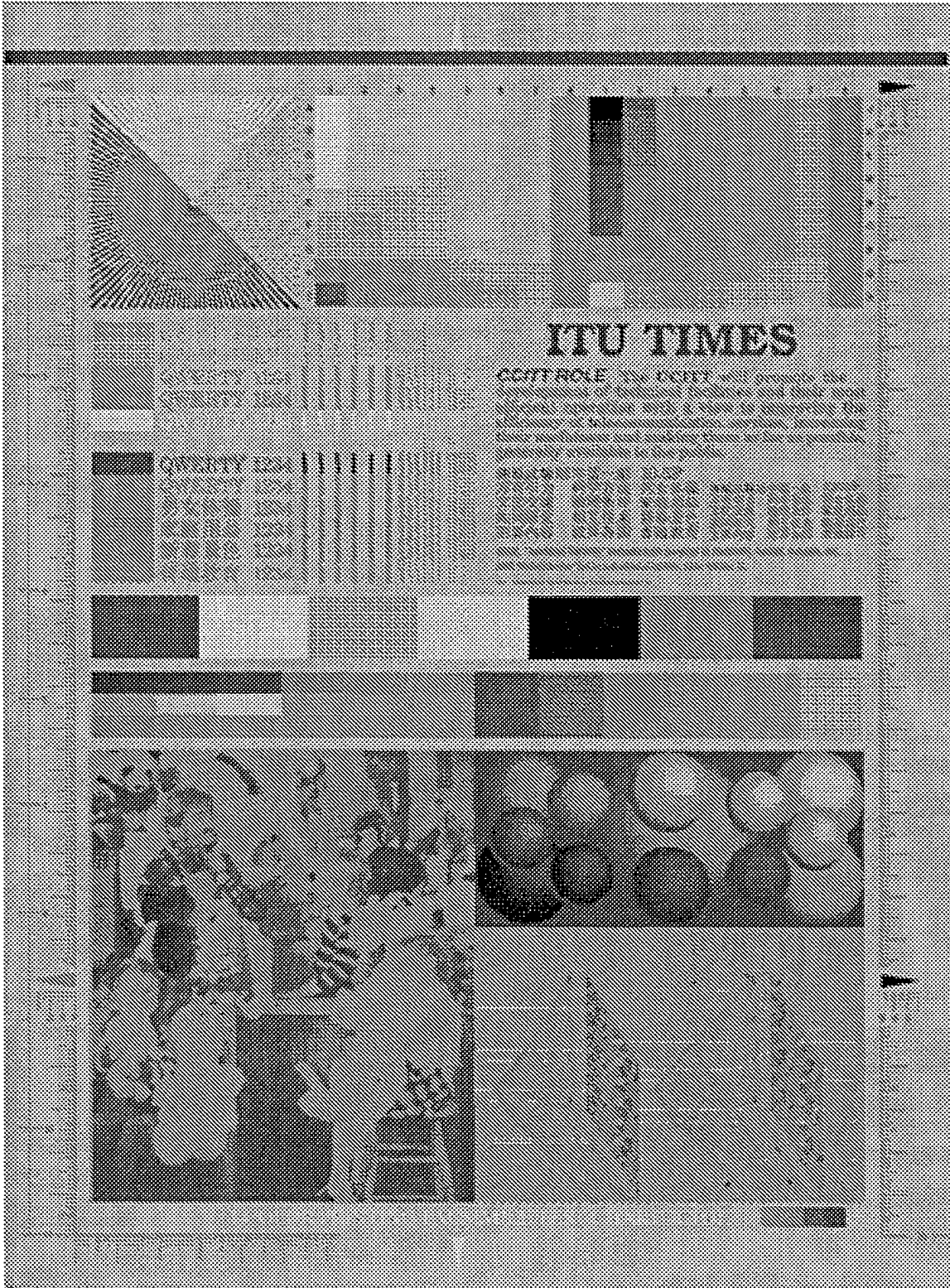

CHART

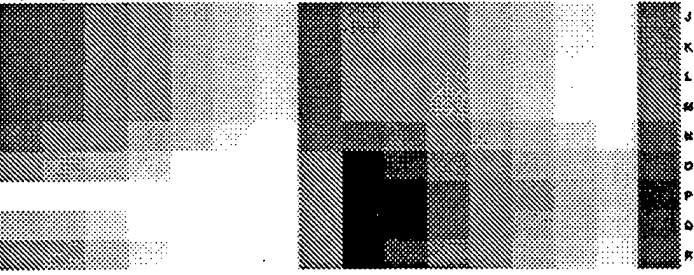
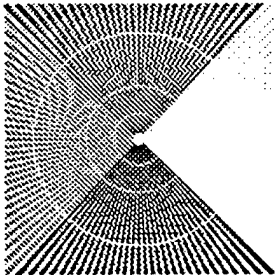

ITU TIMES

CCITT ROLE The CCITT will promote the development of technical facilities and their most efficient operation with a view to improving the efficiency of telecommunication services, increasing their usefulness and making them as far as possible, generally available to the public.

傳輸試驗用字第一組 10.5P
 万有引力 科学方法 男女体操 传输试验用字第一组 7.875P
 文化交流 地理条件 家庭用品 万有引力 科学方法 男女体操
 共同研究 相互往来 新春景色 文件传递 地理条件 家庭用品
 主要内容 世界各國 普通教育 主要內容 世界各國 普通教育

NOTE: "Telemail Services" includes such services as Facsimile, Telex, Videotex, etc.
 NOTE: "Telemail Services" includes such services as Facsimile, Telex, Videotex, etc.

QWERTY 1234
 QWERTY 1234
 QWERTY 1234
 QWERTY 1234
 QWERTY 1234
 QWERTY 1234
 男女体操 1234
 家庭用品 1234
 新春景色 1234
 普通教育 1234

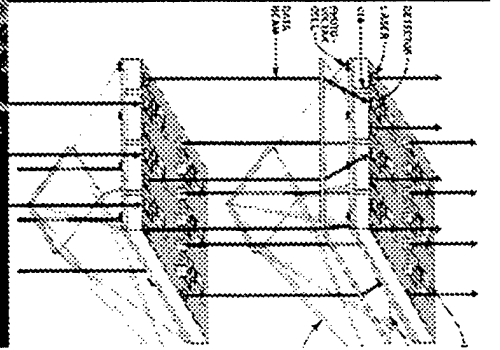
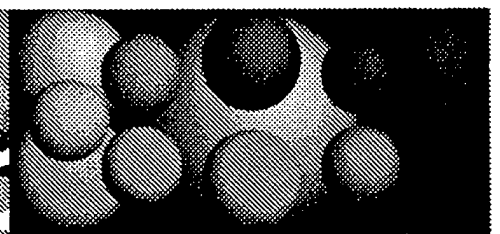
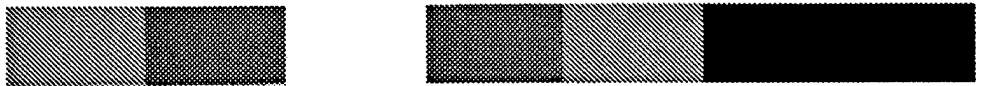

4-COLOR PRINTING FACSIMILE TEST CHART 4CP01



BAND1



La bonne Education.

A Paris chez M. de la Harpe, Libraire de la Cour des Academies.

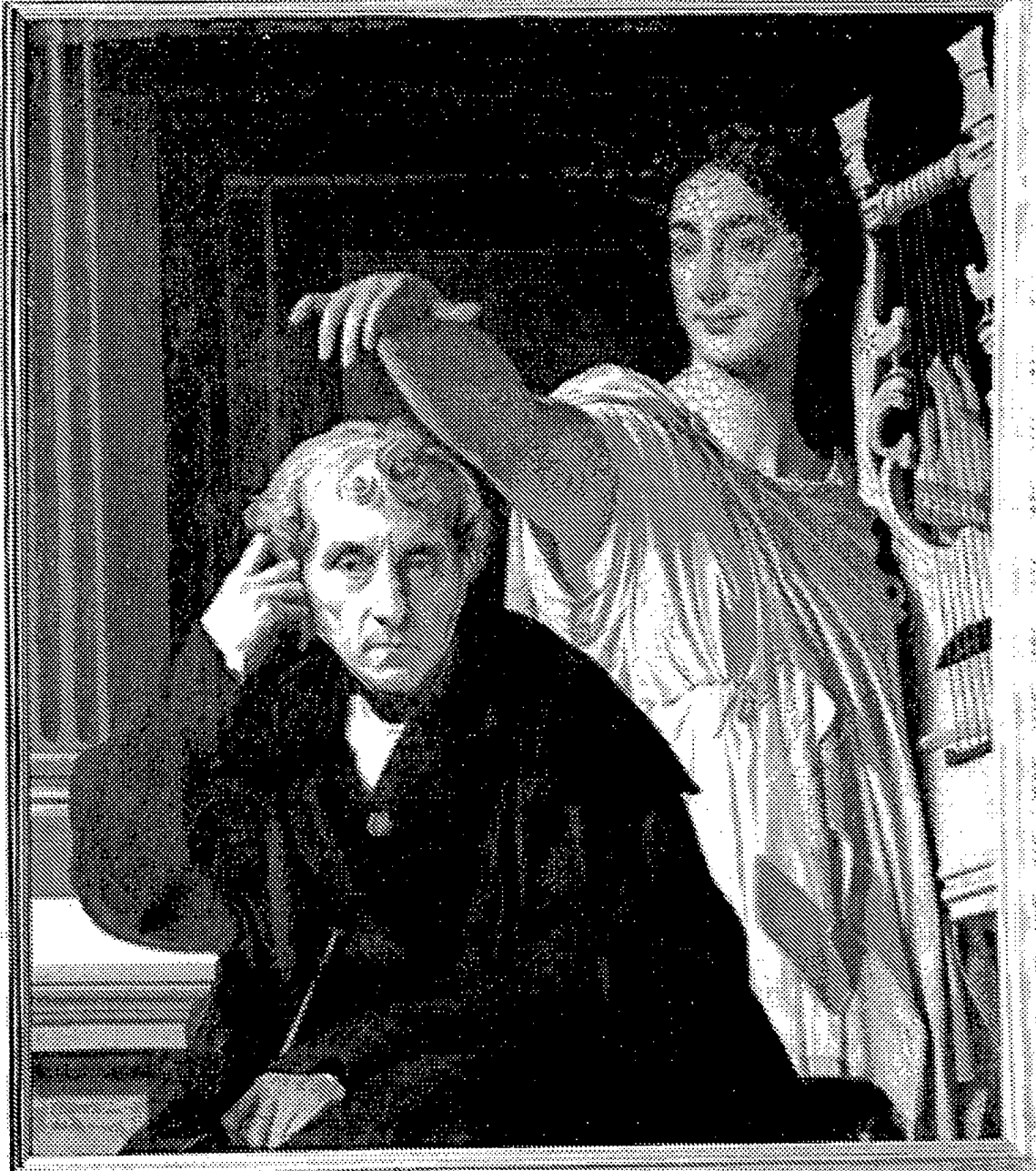

INGRES8

•
•
•
•

Appendix C
Evaluation Criteria for JPEG Compression Algorithms

•
•
•

ISO/IEC JTC1/SC29/WG1
(ITU-T SG8)

Coding of Still Pictures

JBIG	JPEG
Joint Bi-level Image Experts Group	Joint Photographic Experts Group

Title : Evaluation criteria for the lossless continuous-tone image
compression work item (JTC 1.29.12)

Source : ISO/IEC JTC 1/SC 29/WG 1

Project : JTC 1. 29.12

Status : Scoring to be used in the initial evaluation (July 1995, Epernay, France)

Requested Action : Contributors are requested to include performance measures as
described in this document.

Distribution : WG 1 Mailing List, Contributor's to JTC 1.29.12

Evaluation criteria for the lossless continuous-tone image compression work item (JTC1.29.12)

The contributors are welcome to present the system performance using a number of different memory sizes. Only the best will be used for scoring.

Committee's rationale: It is important to consider memory cost when evaluating compression performance. This formula has no compression cost until the memory is over 2^{17} bits. After that amount of memory, the compression performance must achieve about 0.75% better performance for every doubling of memory to have an increase in score. This is considered a very modest scoring hit for large memory utilization and is in keeping with the desire to achieve exceptional compression performance. The applications for this standard are considered to be at the higher end of the market and more tolerant of higher implementation cost.

Near-lossless compression evaluation

There are four categories for near-lossless compression defined by different bounded reconstructed image error at each pixel (component). These bounds are +1, +2, +3, and +7. The scores from each category are added together for the total score. The scoring for each category is as follows:

$$S_{nl} = (3S + S_{rmse}) / 4$$

where S_{nl} is the *near-lossless score*, S is the performance score from above, and S_{rmse} is the score for RMSE. S_{rmse} is the following:

$$S_{rmse} = 100 \frac{(S_{to} \text{ of system under test})}{(\text{Best } S_{to} \text{ of all systems under test})}$$

where S_{to} is the trade off score between compression and RMSE. S_{to} is the following:

$$S_{to} = \frac{0.3 (2^{CG} - 1) \times CG}{(RMSE)}, \quad \text{for } RMSE > 0$$

where CG is the coding gain. CG is the following:

$$CG = \begin{cases} / (BL_{bpp}) - (SUT_{bpp}), & (BL_{bpp}) > (SUT_{bpp}) \\ \backslash 0, & \text{otherwise} \end{cases}$$

where BL_{bpp} is the bits per pixel (or component) of the best lossless compression of that particular image and SUT_{bpp} is the near-lossless bit per pixel of the system under test. RMSE is calculated by the following equation:

$$RMSE = \{ 1/N \sum [(x_{original} - x_{reconstructed})^2] \}^{1/2}$$

where N is the number of pixels (components), $x_{original}$ is the original pixel value, and $x_{reconstructed}$ is the near-losslessly reconstructed image.

Evaluation criteria for the lossless continuous-tone image compression work item (JTC1.29.12)

The contributors are welcome to present the system performance using a number of different memory sizes and/or distortions for each category. Only the best will be used for the scoring.

Committee's rational: A quantitative metric is used because subjective testing of all the images could be costly, time consuming, and, at the near-lossless level of distortion, inconclusive. Although RMSE is far from a perfect metric, it does differentiate image quality. Also, as a measure of image fidelity, RMSE should give some relative idea of how reconstructed images might perform under post-processing. At a later date (probably November 1995, Dallas Texas), after the field of proposals has been reduced, a subjective test could be performed to further differentiate between methods.

Color component cross-correlation usage

Color component cross-correlation may not be used to achieve higher compression for the initial evaluation. This means that each color component band must be compressed independently of other bands in the image. No color transform or adaptive method may be used.

The contributors are welcome to present results that use cross-correlation in addition, however, these results will not be used for scoring.

Committee's rational: To allow color component cross-correlation to be used might unnecessary prejudice the performance of some proposals relative to others. At the initial evaluation it is important to determine the compression performance of the compressor as opposed to the color component cross-correlation method. Eventually this type of correlation will be added for complete system performance. At that time, however, it might be possible to adapt a hybrid system with the best color cross-correlation method and the best compression method.

Description of computation performance

Computation performance in software will not be scored during this initial evaluation. However, contributors are requested to describe the software speed performance for both compression and decompression in terms of bytes/second. Please also describe the type of computer on which these tests were performed. A discussion of the computational complexity in both software and hardware would also be helpful.

Committee's rational: It is the committee's desire that this standard be reasonably implemented in both hardware and software. However, meaningful empirical comparison of the proposals would be very difficult to perform. All of the systems would have to be implemented on the same type of computer and run on the same computer, possibly at great cost and inconvenience. Also, experience has shown that performance improvements on new algorithms are almost always possible. The attention that nascent standards receive almost always leads to creative improvements. To use software performance as a scored criteria might unduly prejudice some proposals.

Other features

Contributors are encouraged to present any additional features offered by their systems. Examples include smooth progressive performance and palletized (indexed) image

Evaluation criteria for the lossless continuous-tone image compression work item (JTC1.29.12)

compression. These features, while not evaluated quantitatively, will defiantly add value to the proposals.

Intellectual property rights

Contributor's are required to disclose any intellectual property rights (held now or currently applied for) that relate to their proposals.

Committee's rational: The interest of the committee is to create a readily usable and accessible standard. It is desirable to avoid difficult negotiations and high costs. The goal is to ensure that the intellectual property rights situation is not more complex than the situation of ISO/IEC 11544(7816).

Test image set

There are 24 images to be used as test images for proposals. All of these images should be used for the lossless and the four near-lossless categories. These images vary widely and attempt to cover the types of images found in probable applications of this standard. The images will be made available to contributors on CD-ROM after 15 April 1995 from the following:

ISO/IEC JTC 1/SC 29/WG 1 Convenor - Eric Hamilton
C-Cube Microsystems, 1778 McCarthy Blvd., Milpitas CA 95035, USA
Tel: 1 408 944 6335, Fax: 1 408 944 8167, E-mail: eric@c-cube.com

Voluntary donations of unetched CD-ROMs to offset the costs are greatly appreciated. All the images are in the TIFF format except hotel and gold, which are in a non-interleaved raw format. The following table describes the images.

Evaluation criteria for the lossless continuous-tone image compression work item (JTC1.29.12)

Name	Source	Bands	Size
hotel	CCIR 601	YCrCb, 8 bpc, 4:2:2	720 x 576
gold	CCIR 601	YCrCb, 8 bpc, 4:2:0	720 x 576
woman	SCID	CYMK, 8 bpc	2560 x 2048
bike	SCID	CYMK, 8 bpc	2560 x 2048
cafe	SCID	CYMK, 8 bpc	2560 x 2048
tools	Crosfield drum scan	CYMK, 8 bpc	1524 x 1200
bike3	Crosfield digital cam.	RGB, 8 bpc	919 x 2103
water	PhotoCD	RGB, 8 bpc	2048 x 3072
cats	PhotoCD	RGB, 8 bpc	2048 x 3072
aerial1	aerial photo	RGB, 8 bpc	1024 x 1024
aerial2	aerial photo	mono, 16 bits (12 bit)	1024 x 1024
art1	scan of engraving	mono, 8 bits	5912 x 7268
art2	scan of painting	RGB, 12 bpc	5912 x 7268
x-ray	medical x-ray	mono, 16 bits (12 bit)	1680 x 2048
ct	computer tomography	mono, 16 bits (13 bit)	512 x 512
cr	computer radiology	mono, 16 bits (10 bit)	1744 x 2048
us	ultrasound	mono, 8 bits	512 x 448
mri	magnetic resonance	mono, 16 bits (12 bit)	256 x 256
faxballs	computer generated	CIE Lab, 8 bpc, 1:1:1	1024 x 512
graphic	computer generated	CIE Lab, 8 bpc, 1:1:1	2644 x 3046
chart	computer generated	CIE Lab, 8 bpc, 1:1:1	1752 x 2375
chart_s	scan of chart	RGB, 8 bpc	1688 x 2347
finger	fingerprint	mono, 8 bits	512 x 512
compound	computer generated	RGB, 8 bpc	768 x 512

The images "woman", "bike", and "cafe" are provided by the Image Processing Technology, Standard (IPPTS), Japan.

The images "tools" and "bike3" are provided by Crosfield Electronics, PLC.

The images "water" and "cats" are provided by Mr. Phil Fennessy.

The images "art1" and "art2" are provided by the French Ministry of Culture.

The images "x-ray", "ct", "cr", "us", and "mri" are provided by Mallinckrodt Institute of Radiology at Washington University School of Medicine (Saint Louis, MO).

The image "finger" was provided by the United Kingdom Home Office.