

AD _____

GRANT NO: DAMD 17-94-J-4207

TITLE: Reaching Black Women for a Dietary Intervention to Reduce Breast Cancer Risk

PRINCIPAL INVESTIGATOR: Margaret K. Hargreaves, Ph.D.

CONTRACTING ORGANIZATION: Meharry Medical College
Nashville, Tennessee 37208

REPORT DATE: September 1996

TYPE OF REPORT: Annual

PREPARED FOR: U.S. Army Medical Research and Material Command
Fort Detrick, Maryland 21702-5012

DISTRIBUTION STATEMENT: Approved for public release; distribution unlimited

The views, opinions and/or findings contained in this report are those of the author(s) and should not be constructed as an official Department of the Army position, policy or decision unless so designated by other documentation.

DTIC QUALITY INSPECTED 1

REPORT DOCUMENTATION PAGE

Form Approved
OMB No. 0704-0188

Public reporting burden for this collection of information is estimated to average 1 hour per response, including the time for reviewing instructions, searching existing data sources, gathering and maintaining the data needed, and completing and reviewing the collection of information. Send comments regarding this burden estimate or any other aspect of this collection of information, including suggestions for reducing this burden, to Washington Headquarters Services, Directorate for Information Operations and Reports, 1215 Jefferson Davis Highway, Suite 1204, Arlington, VA 22202-4302, and to the Office of Management and Budget, Paperwork Reduction Project (0704-0188), Washington, DC 20503.

1. AGENCY USE ONLY (Leave blank)		2. REPORT DATE September 1996	3. REPORT TYPE AND DATES COVERED Annual (15 Aug 95 - 14 Aug 96)	
4. TITLE AND SUBTITLE Reaching Black Women for a Dietary Intervention to Reduce Breast Cancer Risk			5. FUNDING NUMBERS DAMD17-94-J-4207	
6. AUTHOR(S) Margaret K. Hargreaves, Ph.D.				
7. PERFORMING ORGANIZATION NAME(S) AND ADDRESS(ES) Meharry Medical College Nashville, TN 37208			8. PERFORMING ORGANIZATION REPORT NUMBER	
9. SPONSORING/MONITORING AGENCY NAME(S) AND ADDRESS(ES) Commander U.S. Army Medical Research and Materiel Command Fort Detrick, MD 21702-5012			10. SPONSORING/MONITORING AGENCY REPORT NUMBER	
11. SUPPLEMENTARY NOTES			19970113 040	
12a. DISTRIBUTION / AVAILABILITY STATEMENT Approved for public release; distribution unlimited			12b. DISTRIBUTION CODE	
13. ABSTRACT (Maximum 200) This report presents information on four parallel lines of investigation: 1) The Questionnaire measuring the Transtheoretical Model (TTM) constructs of Stage, Process, Decisional Balance, Self Efficacy, and Situational Temptation were validated in a sample of 207 African-American Women (mean age, 40 years; average educational level, 14.9 years), when compared with results obtained in a white population. 2) Correlational analyses between reported stage of change and dietary fat intake revealed a discrepancy in perception of fat intake and dietary behaviors at the higher stages of change. An Eating Styles Questionnaire (ESQ) developed from results of a cluster analysis revealed where individuals fail in the process of selecting appropriate foods when changing dietary fat intake. The ESQ should facilitate dietary counseling procedures. 3) A 52-item Eating Behavior Patterns Questionnaire (EBPQ) has been developed, and six factor-analytically-derived scales have been derived (low fat eating, snacking and convenience, planning, emotional eating, meal skipping, cultural/ lifestyle factors). The EBPQ promises a good approach to behavioral assessment of dietary fat intake. 4) The second draft of a Dietary Intervention Manual has been prepared to facilitate behavior change in African-American Women, using the TTM guidelines. This intervention will be tested in 200 women in Year 3 of the project.				
14. SUBJECT TERMS Breast Cancer			15. NUMBER OF PAGES 179	
			16. PRICE CODE	
17. SECURITY CLASSIFICATION OF REPORT Unclassified	18. SECURITY CLASSIFICATION OF THIS PAGE Unclassified	19. SECURITY CLASSIFICATION OF ABSTRACT Unclassified	20. LIMITATION OF ABSTRACT Unlimited	

DISCLAIMER NOTICE



THIS DOCUMENT IS BEST QUALITY AVAILABLE. THE COPY FURNISHED TO DTIC CONTAINED A SIGNIFICANT NUMBER OF PAGES WHICH DO NOT REPRODUCE LEGIBLY.

FOREWORD

Opinions, interpretations, conclusions and recommendations are those of the author and are not necessarily endorsed by the US Army.

___ Where copyrighted material is quoted, permission has been obtained to use such material.

___ Where material from documents designated for limited distribution is quoted, permission has been obtained to use the material.

___ Citations of commercial organizations and trade names in this report do not constitute an official Department of Army endorsement or approval of the products or services of these organizations.

___ In conducting research using animals, the investigator(s) adhered to the "Guide for the Care and Use of Laboratory Animals," prepared by the Committee on Care and Use of Laboratory Animals of the Institute of Laboratory Resources, National Research Council (NIH Publication No. 86-23, Revised 1985).

For the protection of human subjects, the investigator(s) adhered to policies of applicable Federal Law 45 CFR 46.

___ In conducting research utilizing recombinant DNA technology, the investigator(s) adhered to current guidelines promulgated by the National Institute of Health.

___ In the conduct of research utilizing recombinant DNA, the investigator(s) adhered to the NIH Guidelines for Research Involving Recombinant DNA Molecules.

___ In the conduct of research involving hazardous organisms, the investigator(s) adhered to the CDC-NIH Guide for Biosafety in Microbiological and Biomedical Laboratories.

Darrell N. Hargreaves
PI - Signature

Sept 14, 1996

Date

Table of Contents

1.	Front Cover	1
2.	Documentation Page (SF 298).....	2
3.	Foreword.....	3
4.	Table of Contents	4
5.	List of Tables and Figures.....	5-6
6.	Introduction.....	7
7.	Body of the Report.....	15
	A. Questionnaire Validation.....	16
	1. Purpose.....	17
	2. Procedures.....	17-18
	3. Results.....	19-22
	4. External Validity Analyses.....	23-28
	5. References.....	29-30
	6. Tables and Figures.....	31-54
	B. Stages of Change and the Intake of Dietary Fat in African American Women.....	55
	1. Purpose.....	56
	2. Procedures.....	57
	3. Results.....	58-63
	4. References.....	64-65
	5. Tables and Figures.....	66-76
	6. Appendix.....	77
	C. Development and Evaluation of An Eating Behavior Patterns Questionnaire.....	81
	1. Purpose.....	82
	2. Procedures.....	83-84
	3. Results.....	85-86
	4. Discussion.....	87
	5. References.....	88-89
	6. Tables.....	90-92
	7. Appendix.....	93
	D. Development of The Dietary Intervention Manual.....	123
	1. Purpose.....	124
	2. Procedures.....	124
	3. Results.....	125
	4. Discussion.....	126
	5. Conclusions.....	126
	6. Tables.....	127-130
	7. Appendix.....	131
8.	Conclusions.....	177

List of Tables and Figures

A. Questionnaire Validation.....	16
Table 1. Stage of Change Using Algorithm 1 (Belief & Intention Criterion Alone).....	31
Table 2: Stage of Change Using Algorithm 2 (30% Criterion).....	32
Table 3: Stage of Change Using Algorithm 2 (25% Criterion).....	33
Table 4. Principle Component Factor Loadings for 16 Decisional Balance Item Scale.....	34
Table 5. New 8 item Pros and Cons Scale.....	35
Table 6. Scale Means, SD and Alphas for Study Two Transtheoretical Based Dietary Fat Reduction Instruments.....	36
Table 7. Comparison of Processes of Change Internal Consistency Analyses	37
Table 8. Correlations on the Transtheoretical Model Based Measures Developed and Social Desirability.....	38
Table 9. Means and SD in T Scores for the Processes By Stage of Change.....	39
Table 10. The Group Centroids and Ordered Structure Matrix.....	40
Table 11. Means and SD in T Scores for the Pros and Cons By Stage of Change.....	41
Table 12. Means and SD in T Scores for Situational Temptation By Stage of Change.....	42
Table 13. Means and SD in T Scores for Situational Self-Efficacy By Stage of Change.....	43
Figure 1. Meharry Confirmatory Old Decisional Balance 2 Factor Model.....	44
Figure 2. Meharry Confirmatory New Decisional Balance 2 Factor Model.....	45
Figure 3. Situational Temptation Model for Dietary Fat Reduction in African American Women:Sample 2.....	46
Figure 4. Hierarchical Model of Temptation African-American Women Sample 2.....	47
Figure 5. Hierarchical Model of Confidence African-American Women Sample 2.....	48
Figure 6. Hierarchical Model of Confidence African-American Women Sample 2.....	49
Figure 7. Processes of Change for Dietary Fat Reduction In African American Women: Sample 50	50
Figure 8. Hierarchical Process of Change Model For Sample Two.....	51
Figure 9. Processes of Change Use By Stage For African-American Women Sample 2.....	52
Figure 10. Pros and Cons of Reducing Dietary Fat for African-American Women Sample Two.....	53
Figure 11. Situational Temptation and Confidence for African-American Women Sample Two.....	54
B. Stages of Change and the Intake of Dietary Fat in African Women.....	55
Table 1. Fat and Fiber Intake by Age, Education, and Income in 174 African American Women.....	66

Table 2.	Fat and Fiber Intake by Stage of Change in 174 African American Women.....	67
Table 3.	Stage of Change and Success in Reducing Dietary Fat Intake in 174 African American Women.....	68
Table 4.	Comparison of Subject Groups on Food Clusters.....	69
Table 5.	Fat and Fiber Intake by Age, Education, and Income in 208 African American Women.....	70
Table 6.	Fat and Fiber Intake by Stage of Change in 208 African American Women.....	71
Table 7.	Comparison of Subject Groups on the Eating Style Questionnaire.....	72
Table 8.	Effects of Different Restaging Strategies in 200 African American Women.....	73
Figure 1.	Stage of Change by Age in 174 African American Women.....	74
Figure 2.	Results of Hierarchical Cluster Analysis of Quick Dietary Screening Questionnaire.....	75
Figure 3.	Stage of Change by Age in 208 African American Women.....	76

C. Development and Evaluation of An Eating Behavior Patterns Questionnaire.....77

Table 1.	Outline of Focus Group Protocol.....	90
Table 2.	Seven Factors of the Final Version of The Eating Behavior Patterns Questionnaire.....	91
Table 3.	Correlation of Eating Behavior Patterns Questionnaire with Selected Nutrient Data.....	92
Table 4.	Relationship between the Eating Behavior Patterns Questionnaire and Nutrient Intake for 70 Subjects.....	92

D. Development of The Dietary Intervention Manual

Table 1.	Posters and Brochures Used for Dietary Intervention Sessions.....	127
Table 2.	Summary Charts From Dietary Intervention Focus Groups.....	128
Table 3.	Recommended Schedule for Dietary Intervention Sessions For Each Stage Of Dietary Change.....	129
Table 4.	Focus Group Responses To Dietary Intervention Posters and Brochures.....	130

INTRODUCTION

NATURE OF THE PROBLEM

Fat and fiber have been implicated as important food factors associated with cancers of the colon, breast and prostate (1,2). The National Cancer Institute (NCI), in its support of dietary guidelines to reduce fat and increase fiber in the American diet, has calculated that "at a minimum, 30,000 lives could be saved by the year 2,000 if Americans would modify their dietary habits" (3). Recent reports indicate that Black Americans have a high burden for these cancers (4), and preferentially select high fat, low fiber diets (5). When compared with Whites, Black Americans (cumulative to age 70 years, 1979-81 data) suffered 8,118 excess deaths from cancer (6). It is believed that modification of dietary intakes for these food factors could have enormous benefit for cancer prevention; however, the evidence is inconclusive.

Recently, two multi-center clinical trials were implemented to determine whether a low fat eating pattern would reduce the risk of breast cancer, colon cancer, and heart disease. The Women's Health Trial was an 18 month initiative funded in 1991/92 at three sites to determine whether Blacks and Hispanics (50 - 69 years of age) could participate in a low fat clinical trial as successfully as Whites. A trial implemented in 1984 had shown that Whites could successfully lower their fat intakes by 30% [to $\leq 20\%$ of total calories] in 24 months, their serum cholesterol by 20%, and their plasma estradiol by 17% (7-10). The Women's Health Initiative, funded in 1992 will follow 48,000 women at 45 sites over 9 years. Minority women will be represented in at least the proportion found in the general population of women 50-79 years of age (17% by the 1990 census). The overall protocol and nutrition program of these Trials are based upon those developed in the first trial with Whites (7-10).

The purpose of the proposed study is to develop and test a culturally-sensitive low-fat dietary program for Black women because of their unique culture and food choices as described below, and the known difficulties of reaching blacks for their participation in risk reduction/health promotion programs (11- 15).

BACKGROUND OF PREVIOUS WORK

Black Food Choices

Personal and socio-cultural factors appear to affect black food choices. The typical Black diet has its origins in the slave culture of the South (16). It is high in fat and low in fiber. The diet is characterized by fried meats and vegetables, greens boiled at length with fat back or salt pork, grits eaten with butter, and sweetened fruit drinks or pop instead of fresh fruit. Such a pervasive cultural force is expected to be hard to change. Indeed, Goldsmith and Davidson reported on the success of incorporating ethnic preferences for foods such as pig ears, pig's feet, hog maw, pig tails, crackling, chitterlings, pig brain, fried and boiled chicken, collards, green beans, black-eyed peas, and turnip greens into a Diabetic Exchange List for Black diabetics attending Grady Hospital in Atlanta (17). Success was achieved through the weight lost by patients over five years of treatment. These practices are believed to satisfy important psychological needs (18,19)

Jerome has reported on the changes made by southern rural Blacks becoming acculturated to a northern urban setting in Centralia, Milwaukee (20). Her classic work describes four 'micro-cultural' groups in different states of change: those "surviving" (I); "making it" (II); "enjoying it" (III); and "living passively" (IV). These groups differed in their food choices and relationships to the original southern pattern. It is possible that many American Blacks are in a state of acculturation to the new foodstuffs on the market in relation to their traditional or "soul" foods. Yep and Hollenbeck (21) identified three intercultural lifestyles--assimilation, pluralism, and separateness--that they encountered while providing extension services to racial minorities, and which affected program content and approaches. The questions arise: How well can Blacks who have difficulty becoming acculturated to new food patterns be changed with respect to dietary risk factors? Which groups change? How can resistant Blacks be encouraged to change for their health's sake? These are ultimate questions to which we hope our approach will begin to provide some answers. The data indicate that different loci of control are operating in Blacks, and therefore different strategies should be used to reach them.

According to Hertzler (22), nutrition educators need to know more about the cultural context in

which foods are selected if they expect to change food behaviors and ultimately nutritional and health status. Hertzler defines the content and context of food selection. The content describes the actual food intake--what it is, how it is prepared, and by whom. Content is generally classified as food habits/patterns, food groups, nutrients, etc.--items that can be seen or easily measured. The context describes the meanings given to food--they may be connotative (those dealing with the physical and economic properties of food), or based on imagery (those dealing with the emotional feelings which the food engenders).

Models for Dietary Behavior Change

Several factors influence food choice (23-26). Models developed to show the relationships between these factors include variables from many sources. Sims, for example, developed a model for examining food choice within an ecological system perspective (26). In this model, the external environment is affected by natural (food production), technological (food availability), and socio-cultural influences; the internal environment is affected by personal attributes such as knowledge, attitudes, beliefs, and values. Shepherd (27,28), and Baranowski (29) have argued that a number of these influences operate through the attitudes and beliefs held by individuals, and our earlier arguments indicate that socio-cultural influences are important for Blacks (4-20).

To examine the many influences, one needs to adopt an appropriate framework within which to study them (22). But until recently, most studies of dietary behavior change and nutrition education had focused on knowledge dissemination and had largely been a theoretical (30-33). Nitzke and Athens (34) found only 30 of 157 studies of dietary behavior change specified the use of any identifiable theory or model. Theoretical frameworks which have been used in nutrition include Bandura's Social Learning Theory (31,32,35), Ajzen and Fishbein's Theory of Reasoned Action (36), Becker's Health Belief Model (37,38), Marlatt and Gordon's relapse prevention model (39), and Bandura's Theory of Self-Efficacy (37). Behavioral skills-oriented approaches from Social Learning Theory have been utilized in weight control and diabetes education programs with mixed success (40,41). The Health Belief Model has been effective in predicting dietary adherence in some (37,42) but not all studies (38). Self-efficacy appears to be an important intervening variable for initiating and maintaining dietary change (38,39,42). However, none of these models has been effective in predicting specific dietary changes such as reduction in dietary fat intake to $\leq 30\%$ of calories and these models have failed to explain why most people fail to adhere to modified diets.

A model which has not been much used in nutrition but has been effective in describing change in a variety of other health related areas is the Transtheoretical Model of Behavior Change (44-46). This Model describes *when*, *how* and *why* people change behavior over time. Longitudinal studies of change have found that people pass through the following five *stages*: *precontemplation* (no intention to change), *contemplation* (seriously considering change), *preparation* (taking steps to change), *action* (actively involved in meaningful change), and *maintenance* (maintaining meaningful change) (45). The concept of *stages* describes *when* change occurs and is central to the Transtheoretical Model. However, the progression through stages to maintenance is rarely linear; some people become stuck at one stage and most people *relapse* and recycle back to a previous stage several times before successfully changing their behavior (Prochaska, in press). Studies have shown the *processes* (activities or strategies) people utilize to change vary according to stage of change (45,47). These processes describe *how* people change their behavior. Although not as clearly defined as stages and processes, results suggest that *Why* people change can be explained in part by *decisional balance* positive aspects (pros) versus negative aspects (cons) of changing the behavior (48) and, to a more stage specific extent, by perceived *self-efficacy* to resist temptations to engage in the target behavior. *Self-efficacy* has been particularly important in predicting relapse (49) and may be an important variable for understanding dietary change as well (37). The *decisional balance* dimension of the model has been successful in predicting the decision to move from precontemplation to contemplation (50,51).

Not only is The Transtheoretical Model a predictive model, it also is an integrative model that shows where *other models* fit into the change process. The Transtheoretical Model incorporates aspects of the Health Belief Model (52) and Fishbein's (53) Behavioral Intentions Model into processes of change used by precontemplators moving to the contemplation stage of change (50).

Behavioral processes derived from Social Learning Theory (54) are useful for people in the action or maintenance stage of change (55). The pros and cons of behavior change (decisional balance) were developed from Janis and Mann's (56) decision making model. Bandura's (57) model of self-efficacy and Shiffman's (58) coping models have been incorporated into the self-efficacy to resist temptations component of the Transtheoretical Model. Thus the Transtheoretical Model is a "meta" model incorporating aspects of other models into its theoretical core. Such integration constitutes an inherently strong approach to model building and has been advocated for model building in general (42) and for dietary change in particular (32,59).

Dietary Change Program to Reduce Fat Intake

Dietary intervention programs aimed at reducing fat intake have had a mixed record of success. The Multiple Risk Factor Intervention Trial (MRFIT) (60), the Oslo study (61) and the Hypertension Control Program (HCP) (62) targeted fat reduction among other dietary goals; the Breast Dysplasia Intervention Trial (BDIT) (63), Nutrition Adjuvant Study (NAS)(64), and the Women's Health Trial (WHT)(7-9) focused on dietary fat reduction to approximately 20% of calories as the only dietary intervention.

The BDIT, NAS and WHT followed highly selective recruitment protocols in selecting women with or at high risk for breast cancer who were likely to comply with the rigorous data collection procedures (9,63,64). The BDIT and NAS set a goal of dietary fat at 15% of calories in contrast to the WHT's goal of 20% of calories. Nevertheless, the studies demonstrated similar results at follow-up ranging from 3 months to 2 years. The intervention groups (combined n=209) reduced dietary fat to 22 - 23% of calories; this level of dietary fat was significantly lower than the control groups' (combined n=140) intake of 36 - 37% of calories. All three studies utilized intensive intervention programs with trained professionals and detailed educational materials. The WHT study found that changes in eating patterns in dairy products, red meats and fats/oils accounted for 70% of the observed decrease in fat intake.

Women in the WHT demonstrated that dietary interventions can be effective in reducing dietary fat intake to $\leq 30\%$ of calories; 85% of the intervention group met this criterion at the 2 year follow-up. However, only 44% of these women could be defined as adhering to their dietary prescription of $\leq 20\%$ calories from fat, an adherence rate similar to the 40% found in MRFIT and in other studies of dietary adherence (31).

PURPOSE OF PRESENT WORK

Although the Women's Health Trial, Breast Dysplasia Intervention Trial, and Nutrition Adjuvant Study demonstrated that dietary fat reduction to $\leq 30\%$ of calories was feasible for highly selected groups of women, other interventions to reduce dietary fat have been less successful. Because of their food habits, Blacks are expected to find it even more difficult to adopt a low-fat diet. The National Cancer Institute has targeted dietary fat reduction as a major priority; however, existing models of dietary change have been unsuccessful in predicting change. The Transtheoretical Model has been effective in describing change in a variety of health related areas and, if extended to dietary fat reduction, and for Blacks, offers the potential for increasing our understanding of the process of change for this population group. Research on other behaviors explains why highly effective interventions only work for a small proportion of the population. Interventions designed to move people from one stage to the next can be highly effective. Action oriented programs are likely to fail for the majority of the population that is just thinking about change. People who progressed just one stage in a six month period doubled the chances they would move into the action stage of quitting smoking during the subsequent six months (65).

METHODOLOGICAL APPROACH

Overview

This proposal will develop and validate an algorithm that defines stages of change in reducing dietary fat intake to $\leq 25\%$ of calories and will develop instruments measuring processes, decisional balance, temptation, and self-efficacy in Black women. In addition, we will conduct a longitudinal study to determine how the constructs of the model can be used to move these women from stage to stage. Strecher et al. (66) have successfully used this model in a computer format with Blacks attending a health clinic in North Carolina. Our approach will test a multi-strategic interpersonal approach.

A substantial amount of work has already been conducted on adapting the transtheoretical model to the problem of dietary fat reduction (67-70). This work has resulted in the development of a reliable and valid set of instruments for measuring all of the transtheoretical model constructs in primarily white populations. The first stage of our work will be to adapt these instruments to a population of black women living in Nashville, Tennessee.

Project Design

Year 1: Instrument Development Two studies will be conducted to develop Transtheoretical Model based dietary fat reduction measures applicable to Black women. *Study 1* is divided into 2 parts. Part 1 will use stage matched focus groups to adapt measures previously developed on Whites to our target population of Black Women. Part 2 focuses on exploratory instrument development. *Study 2* will validate the instruments developed in *Study 1*. *Study 2* is also divided into 2 parts. Part 1 is devoted to Confirmatory Instrument Development. Part 2 focuses on external validation of the instruments.

Year 2: Intervention Program Development and Pilot Testing (*Study 3*)

Years 2 and 3: Small-scale Community Demonstration Trial with Longitudinal follow-up (*Study 4*)

References

1. Doll R, Peto R. The causes of cancer: quantitative estimates of avoidable risks of cancer in the United States today. *JNCI* 66: 1191-1308, 1981.
2. Nigro ND, Bull AW. Prospects for the prevention of colorectal cancer dis. *Colon Rectum* 30: 571-754, 1987.
3. Greenwald P, Sondik EJ. Editors. *Cancer Control Objectives for the Nation: 1985-2000*. NCI Monograph 2: 1-105, 1986.
4. Baquet CR, Ringen K, Pollack ES et al. *Cancer Among Blacks and other Minorities: Statistical Profiles*. DS Publication <PHS# No 86-2785, Washington DC: US Govt. Printing Office, 1986.
5. Hargreaves MK, Baquet CR, Gamshadzi A- Diet, nutritional status, and cancer risk in American Blacks. *Nutr. Cancer* 12: 1-28, 1989.
6. Heckler M. Report of the Secretary's Task Force on Black and Minority Health Vol. 1: Executive Summary USDHHS, August 1985.
7. Insull W, Henderson MM, Prentice RL, et al. Results of a randomized feasibility study of a low-fat diet. *Arch. Intern. Med.* 150: 421-7, 1990.
8. Henderson NM, Kushi LH, Thompson DJ, et al. Feasibility of a randomized trial of a low-fat diet for the prevention of breast cancer: Dietary compliance in the Women's Health Trial Vanguard Study. *Prev. Med.* 19: 115-33, 1990.
9. Gorbach SL, Morrill-LaBrode A, Woods MN, et al. Changes in food patterns during a low-fat dietary intervention in women. *J. Am. Diet Assoc.* 90: 802-9, 1990.
10. Prentice RI, Thompson DJ, Clifford C, et al. Dietary fat and plasma estradiol concentration among healthy post-menopausal women. *JNCI* 82:129-34, 1990.
11. Miller BA, Riel LAG, Hankey BF, et al. *Cancer statistics review: 1973-1998*. National Cancer Institute. NIH Publ. No. 92-2789, 1992.
12. EVAXX. *A study of Black Americans' Attitudes Toward Cancer and Cancer Tests*. New York: ACS, 1980.
13. The Lipid Research Clinics Coronary Primary Prevention Trial Results. 1. Reduction in incidence of coronary heart disease. Lipid Research Clinics Program. Lipid Metabolism-Atherogenesis Branch, NHLBI. *JAMA* 251: 351, 1984.
14. Williams M, Colling A et al. Development of Diffusion Strategies Among Culturally - Diverse Populations. Final Report to the NHLBI prepared under contract No. NOI-HO2-7003.
15. Warnecke PB. Intervention in black populations. *Prog Clin Biol Res* 53: 167-183, 1981.
16. Hargreaves, MK. Socio-cultural influences on black American food habits from slavery until now. Paper presented at the Conference on "Afro-American Culture and History" for the Nashville and Tennessee Historical Commissions and Tennessee State University, February 8, 1989.
17. Dennis R. Psycho-social aspects of the folk medicine of the black elderly. Paper submitted to the Second Annual Meeting of the Southern Gerontological Society. Atlanta GA, 1981.
18. Mathews HF. Rootwork: Description of an ethnomedical system in the American South. *South Med. J.* 80: 885-891, 1987.
19. Goldsmith MP, Davidson JR. Southern ethnic food preferences and exchange values for the diabetic diet. *JADA* 70: 61-64, 1977.
20. Jerome NW. Diet and Acculturation: The Case of Black-American In-Migrants. In *Nutritional Anthropology: Contemporary Approaches to Diet and Culture*, with R. Kandel and G. Pelto. New York: Redgrave Publishing Co., 1980.
21. Yep B., Hollenbeck M. A way to reach minorities: multicultural awareness. *J. Extension* 17: 4-9, 1979.
22. Hertzler AA, Wenkam N, Standal B. Classifying cultural food habits and meanings. *JADA* 80: 421-425, 1982.
23. Khan MA. Evaluation of food selection patterns and preferences. *CRC Critical Reviews in Food Science and Nutrition* 15: 129-153, 1981.

24. Randall E. Sanjur D. Food preferences - their conceptualization and relationship to consumption. *Ecology of Food and Nutrition*, 11:151-161, 1981.
25. Shepherd R. Dietary salt intake.. *Nutrition and Food Science* 96:10-11, 1985.
26. Sims LS. Further thoughts on research perspectives in nutrition education. *J. Nutr Ed* 13:S70-75, 1981.
27. Shepherd R. The effects of nutritional beliefs and values on food acceptance. In J Solms, DA Booth, RM Pangbom, O Raunhardt (Eds) Food Acceptance and Nutrition pp. 387402, 1987. London: Academic Press.
28. Shepherd R. Factors influencing food preferences and choice. In R Shepherd (ed.), Handbook of the Psychophysiology of Human Eating. Chichester: Wiley, In Press.
29. Baranowski, T. Beliefs as motivational influences at stages in behavior change. *Intl. Q. Comm. H.Ed.* 13: 3-29,1992-93.
30. Achterberg, CL Factors that influence learner readiness. Journal of the American Dietetic Association-88, 1426-1428. 1988.
31. Glanz, K, & Mullis, RM. Environmental Interventions to promote healthy eating: A review of models, programs and evidence. Health Education Quarterly, 15, 395-415. 1988.
32. Olson, CM, Kelly GL The challenge of implementing theory-based intervention research in nutrition education. Journal of Nutrition Education, 21, 280-284. 1987.
33. Sims, LS. Nutrition education research: reaching toward the leading edge. Journal of the American Dietetic Association, (supplement) 87, (9), 10-18. 1987.
34. Nitzke, SA, & Athens, SP. Journal of Nutrition Education, 19, 266-267. 1987.
35. Holli, BB. Using behavior modification in nutrition counseling. Psychometrika, 30, 179- 185.
36. Saunders, RP & Rahilly S. Influences on intention to reduce dietary intake of fat and sugar. Journal of Nutrition Education, 22, 169-176. 1990.
37. Contento, IR,& Murphy, BM. Psycho-social factors differentiating people who reported making desirable changes in their diets from those who did not. Nutrition Education, 22, 6-14. 1990.
38. Greene, GW, & Strychar, I. A worksite cholesterol screening and education program. Society for Nutrition Education, Anaheim, CA- 1990 July.
39. Grilo, CM, Shiffman, S, & Wing, RR. Relapse crises and coping among dieters. Journal of Consulting, and Clinical Psychology, 57, 488-495. 1989.
40. Wadden, T & Stunkard, A. A controlled trial of a very-low-calorie diet, behavior therapy, and their combination in the treatment of obesity. Journal of Clinical and Consulting Psychology, 54, 582-488. 1986.
41. Greene, G. Behavior modification for adult onset diabetics. The Diabetes Educator, 7 (1),ii. 1981.
42. Cummins, KM, Becker, MH, Kirscht, et al. Psychosocial factors affecting adherence to medical regimens in a group of hemodialysis patients. Medical Care, 20. 567-180. 1982.
43. McCaul, KD, Glasgow, RE, & Schafer, LC. Medical Care, 25, 868-881. 1987.
44. Prochaska, JO & DiClemente, CC. Stages and processes of self-change of smoking: Toward an integrative model of change. Journal of Consulting and Clinical Psychology, 51, 390-395. 1983.
45. Prochaska, JO & DiClemente, CC. Common processes of self-change for smoking, weight control, and psychological distress. In S. Shiffman & T. Willis (Eds.), Coping and Substance Abuse (pp. 345-365). New York: Academic Press. 1985.
46. Prochaska, JO & DiClemente, CC. Towards a comprehensive model of change. In W. Miller & N. Heather (Eds.), Treating Addictive Behaviors (p. 3-27). New York: Plenum Press. 1986.
47. DiClemente, CC, & Prochaska, JO. Self-change and therapy change of smoking behavior: A comparison of processes of change of cessation and maintenance. Addictive Behaviors, 7, 133-142. 1982.
48. Velicer, NW, DiClemente, CC, & Rossi, JS, et al. Relapse situations and self-efficacy: An integrative model. Addictive Behaviors,15, 271-283. 1990.
49. DiClemente, C, Prochaska, J, and Gibertini, M. Self-efficacy and the stages of self-change of smoking. Cognitive Therapy and Research, 9, 181-200. 1985.
50. Velicer, WF, DiClemente, CC, Prochaska, et al. A decisional balance measure for predicting

- smoking cessation. Journal of Personality and Social Psychology, 48, 1279-1289. 1985.
51. Prochaska, JO, Velicer, WF, DiClemente, CC, et al. Journal of Consulting and Clinical Psychology, 56,520-528. 1988.
 52. Becker, MH. The health belief model and sick role behavior. Health Education monographs, 2, 409-419. 1974.
 53. Azjen, I., & Fishbein, M. Understanding attitudes and predicting social behaviors. Englewood Cliffs, NJ: Prentice-Hall.
 54. Bandura, A Self-efficacy mechanism in human agency. American Psychologist, 37, 122- 147. 1982.
 55. Rossi, JS, Prochaska, JO & DiClemente, CC. Processes of change in heavy a light smokers. Journal of Substance Abuse, 1, 1-9. 1988.
 56. Janis, IL & Mann, MA Decision making: A psychological analysis of conflict, choice and commitment. New York: The Free Press. 1977.
 57. Bandura, A- Social Foundations of Thought & Action: A social cognitive theory. Englewood Cliffs, N.W.: Prentice-Hall. 1986.
 58. Shiffman, S. A cluster-analytic classification of smoking relapse episodes. Addictive Behaviors, 11, 295-307. 1986.
 59. Achterberg, CL, Novak, JD, & Gillespie, AH. Theory-driven research as a means to improve nutrition education. Journal of Nutrition Education, 17, 179-184. 1985.
 60. Gorder, DD, Dolecek, TA, Coleman, GG, et al. Dietary intake in the Multiple Risk Factor Intervention Trial (MRFIT): Nutrient and food group changes over 6 years. Journal of American Diet Association, 86, 744. 1986.
 61. Hjermann, L, Holme, I., Volvo B., et al. Effect of diet and smoking intervention on the incidence of coronary heart disease: Report from the Oslo study group of a randomized trial in healthy men. Lancet, 2: 1303, 1981.
 62. Stamler, R, Stamler, J, Grimm, R. et al. Nutritional therapy for high blood pressure. Final report of a four-year randomized controlled trial - The Hypertension Control Program. JAMA, 257:11465. 1987.
 63. Lee-Han, H, Cousins, M, Beaton, M, et al. American Society for Clinical Nutrition, 48, 575-586. 1988.
 64. Buzzard, IM, Asp, EH, Chlebowski, et al. Diet intervention methods to reduce fat intake: Nutrient and food group composition of self-selected low-fat diets. Journal of The American Dietetic Association, 90, 42. 1990.
 65. Prochaska, JO, DiClemente, CC, Velicer, WF, et al. Self-help models and materials for smoking cessation. National Cancer Institute Grant. 1990.
 66. Campbell MK, Develli, BM, Strecker, VJ, et al. The impact of message tailoring on dietary behavior change. (Manuscript in progress.) 1993.
 67. Rossi, SR, Green, GW, Reed, G, et al. [with Rossi, JS]. A comparison of four stages of change algorithms for dietary fat reduction. Paper presented at the 14th annual meeting of the Society of Behavioral Medicine, San Francisco, CA, 1993 March.
 68. Rossi, SR, & Rossi, JS. Processes of change for dietary fat reduction. Paper presented at the 14th annual meeting of the Society of Behavioral Medicine, San Francisco, CA, 1993 March.
 69. Rossi, SR, Rossi, JS, Prochaska, JO, et al. Application of the transtheoretical model of behavior change to dietary fat reduction. International Journal of Psychology, 27, 628, 1992.
 70. Rossi, SR, Rossi, JS, Prochaska, JO, et al. Measurement structure of a decisional balance questionnaire for dietary fat reduction. Paper presented at the 101st annual convention of the American Psychological Association, Toronto, Ontario, Canada, 1993 August.

BODY OF THE REPORT

A . QUESTIONNAIRE VALIDATION

Instrument Development: Procedures, and Results

Data from a second administration of Transtheoretical Model (TTM) on a second sample of 207 African-American women were analyzed during year 02. Results of Study 2 are described below. Study 2 validated many of the results of Study 1 on a larger sample of African-American Women. Additional exploratory analyses were conducted when indicated and confirmatory psychometric procedures (e.g., confirmatory factor analysis, structural equation modeling, etc.) and external validation procedures (e.g., discriminant function analysis, multivariate analysis of variance) were employed when appropriate.

Procedures

Additional Exploratory Instrument Analyses. Analysis for continued instrument development included content validity, item ratings, principal components analysis, item analysis, Coefficient Alpha, and scale intercorrelations. Exploratory measurement procedures using structural equation modeling techniques were also conducted.

Principal Components Analyses. Principal components analysis (PCA) was performed to ascertain an instrument's factor structure using the matrix of interitem correlation coefficients where appropriate. Both Horn's (1965) parallel analysis and Velicer's (1990) MAP rule were used for component extraction since simulation studies have shown they perform best over a wide range of conditions (Zwick & Velicer, 1986). In addition to the use of these statistical guidelines, component extraction was also guided based on the number of component scales theoretically expected.

Confirmatory Measurement Structural Analyses. Measurement analyses using structural modeling techniques were used to confirm scales that were not revised. While a traditional approach to exploratory instrument development typically involves the use of principal components or factor analyses, the use of structural equation modeling techniques in an exploratory mode has recently become recognized as a more powerful and sophisticated approach to instrument development when it is based on a strong theoretical model and is followed up with a confirmatory investigation (Bollen, 1989; Dwyer, 1983; Long, 1983). The Transtheoretical Model of Behavior Change has been demonstrated to be a robust model. To date, replication of the measurement structure of Transtheoretical based instruments has repeatedly been demonstrated across a wide variety of problem areas, populations, and settings. Use of such sophisticated analyses were added to exploratory analyses in this project as it has now become accepted standard procedure in the development of Transtheoretical Model based instruments (Fava, J.L., Velicer, W.F., & Rossi, J.S., 1995). Further structural modeling techniques was employed to test the Processes of Change, Situational Temptation and Situational Self-efficacy models for evidence of hierarchical structure.

Procedure Used for Scale Revision. As a result of exploratory analyses conducted in Study 1, some scales were revised. The elimination or addition of items was made for any of the following reasons. 1) Items were deleted based on PCA results (e.g., low or complex item loadings), or item analyses which resulted in too few items for any scale; this might then require either that the scale be eliminated or that new items be added to a revised version of the instrument. 2) No previously unexpected components emerged as a result of principal components analyses. 3) Skewed items were revised where applicable. New items were written and scales revised based on PCA, and exploratory measurement analysis results, or because specific issues emerged as important in focus groups.

Internal Consistency Analyses. Scale homogeneity, the degree of internal consistency for each of the retained components, was determined using Cronbach's coefficient Alpha. While a value of .80 is highly desirable, values of .60 are considered within acceptable range (Personal Communication, Norm Cliff October 5, Annual Meeting of the Society for Multivariate and Experimental Statistics, Semi Omu, WA.)

Stage of Change: The stage of change algorithm was administered to all subjects so that they could be classified into one of five stages of change: Precontemplation, Contemplation, Preparation, Action or Maintenance. Three algorithms were tested and external validity analyses conducted with Algorithm 1.

Fat Intake Analyses

The Dietary Quick Screen Questionnaire (Kristal et al., 1990) was used to calculate percent of energy from fat.

Social Desirability Analyses. The 20 item true-false Jackson (1967) Social Desirability Scale was used to assess the role, if any, that social desirability played in responding to the Transtheoretical Model of Behavior Change measures being developed for dietary fat reduction for African-American Women. Although a bit dated, the validity of the Jackson (1967) Social Desirability Scale has been well established (Jackson, 1971). The results of the Jackson Scale comparisons with each measure's scales gives some indication of how valid the instruments being developed are. Social Desirability contamination was determined by comparing scale correlations of the instrument being developed with the overall score obtained on the Jackson Social Desirability Scale (Jackson, 1970). Social Desirability contamination was considered to exist for any scale correlating greater than + or - .25 (Jackson, 1970). However, a score of less than 3.0 is within acceptable range.

External Validity Testing. The relationship between subject's Stage of Change and the Transtheoretical Model construct measured by each of the instruments from Study 2 was examined using multivariate analysis of variance (MANOVA) for evidence of external validity. For these analyses, Stage of Change (Algorithm 1), was used as the independent variable, and Processes of Change, Decisional Balance, Situational Temptation and Situational Self-efficacy as dependent measures. Follow-up tests including separate analyses of variance (ANOVA) and Tukey HSD procedures to illuminate group differences among stages of change.

Results

Sample. Confirmatory data on Stage of Change, Decisional Balance, Temptation, Confidence and Processes were analyzed based on completed data from 207 African-American women. The mean age of the sample was 40 years old ($SD = 06.1$). Women had an average educational level of 14.9 years ($SD = 02.9$).

Stage of Change.

Three stages of change algorithms were explored. Algorithm 1 consisted of a traditional algorithm based on beliefs and intentions about reducing dietary fat consumption alone as used by Curry et al (1992) and others. The two other algorithms included beliefs and intentions about reducing dietary fat consumption but required the addition of behavioral criteria for staging subjects in action and maintenance as recommended by Greene et al (1994). Algorithm 2 was based on an intake of 30% or less fat from total daily calories while Algorithm 3 was based on the target intake of 25% or less fat from total daily calories. Only two subjects met the 25% or less fat from daily kcal target. Similarly, only 15 subjects met the 30% or less criterion. Only 0.5% of the sample met the 25% dietary fat intake criteria for action and maintenance, while less than 5% met the 30% dietary fat intake criterion. Thus, validation analyses (e.g., discriminant function analysis, multivariate analysis of variance) could not be conducted using the 25 or 30% algorithms due to large discrepancies in sample size by stage of change. These analyses were therefore conducted using the traditional stage of change algorithm 1. Stage of change distributions for each Algorithm are presented in Tables 1 - 3. Results of the stage of change distributions using the traditional algorithm replicate previous findings of a high number of individuals in the action and maintenance stages despite their failure to meet the recommended levels for dietary fat intake. The stage results in this study suggest that like Whites, many Black Women believe they have reduced their dietary fat consumption to an acceptable level even though their measured dietary behavior indicates they have not.

Dietary Fat Intake. The 53-item Dietary Quick Screen Questionnaire (Kristal et al., 1990) was again used to assess the relative amount of fat subjects consumed in their diet. Mean fat intake for the second sample was 39% ($SD = 06.1$). Dietary fat intake for Black Women in this study was much higher than found in previous TTM studies which used the Dietary Quick Screen Questionnaire to measure fat intake in Whites ($M = 32\%$ to 35%) Greene et al, 1994. These data support dietary fat consumption as a high risk health behavior for African-American Women in particular.

Decisional Balance. Results of exploratory analyses on data from Study 1 had replicated the two factor pros and cons structure previously identified and validated the instrument used in the focus groups and White populations (S. Rossi, 1993; S. Rossi, Greene, Reed, Prochaska, & Velicer, 1993) (Figure 1). However, data from the previous focus groups had identified attitudes and beliefs held by African-American women which indicated that a different set of benefits and costs might be important in reducing fat consumption than used in Whites. Thus,

prior to administration, data from focus groups was used to develop additional pros and cons found to be of importance to African-American women. New pros were concerned with health and many of the cons centered around family issues. The addition of new items allowed for confirmatory testing of the old instrument as well as development of a decisional balance instrument that might be more acceptable to African-American women. Exploratory analyses were conducted on the initial 16 item instrument using PCA ($r = .28$) which indicated the two factors accounted for 48% of the variance (Table 4). Items loaded on the component for which they were designated and exceeded the .50 loading criterion. Item number 7 loaded on the cons (.57) and only minimally (.33) on the pros suggesting it might potentially be considered complex. Factor analyses were conducted to reduce the item set using structural equation modeling techniques to perform measurement modeling. The 16 item set was reduced to 8 items, with the 2 factor structure representing pros and cons replicated. Model fit of the new scale was excellent (CFI = .96, RMS = .04), indicating that the theoretical model fit the data very well (Figure 2). All factor loadings obtained from measurement analyses using structural equation modeling were adequate (exceeded .50 criteria) and ranged from .60 to .84, ($M = .69$). An improvement in the correlation between pros and cons was obtained with a reduction from .78 in the previous sample to ($r = .27$) in the current sample. Internal consistency (Alpha) coefficients for the two decisional balance scales on the new instrument developed for African-American women were lower than in the previous smaller sample but adequate (pros = .82, cons .74, mean = .78). Internal consistency results in the previous focus group sample of African-American women were (pros = .86, = .89, mean = .88). Although endorsement of the pros by African-American women suggests the presence of some bias with regard to the benefits of reducing dietary fat consumption, item means were within acceptable range. The new 8 item decisional balance instrument developed specifically for African-Americans (Table 5) slightly outperformed the one previously developed on Whites and was adopted for the demonstration study in year 03 because of its psychometric properties and acceptability in this population. Scale means, standard deviations and alphas are presented in Table 6.

Temptation. The 3 factor, 9 item structure cross-validated (S. Rossi, Greene, Reed, Prochaska, & Velicer, 1993) in whites was confirmed in this sample of African-American women (Figure 3). The data indicate that African-American women also found the temptation construct relevant. Temptation represents how tempted an individual is to eat high fat foods in three specific situations: positive/social situations, negative/affective situations and difficult situations. Internal consistency (Alpha) coefficients for the three temptation scales ranged from .78 to .92, mean = .85 compared to the focus group (range = .72 to .90, mean = .78) and Whites (range = .80 to .92, mean = .86). The overall 9 item Temptation scale was found to have a good internal consistency coefficient of .89. Item means were acceptable. Confirmatory analyses were conducted using structural modeling techniques. Measurement model loadings obtained using structural modeling techniques were acceptable ranging from .71 to .91, mean = .81). Model fit was excellent (CFI = .98, RMS = .03), indicating that the theoretical model fit the data very well. Correlation between positive social and difficult situations was somewhat higher than desired (.84). Scale means, standard deviations and alphas are presented in Table 6. The final temptation instrument adapted for Black women is

similar to and based on the situational temptation measure for dietary fat reduction previously developed on Whites (Rossi, 1993).

A One factor hierarchical model has been documented in previous TTM temptation studies in which all three lower order situational factors load on a single higher order factor representing overall temptation. Results provide an additional test of the applicability of the Transtheoretical Model Temptation construct to dietary fat reduction. The 9 item, 3 correlated factors model derived in Study 2 was used as a basis for this analysis. Results revealed a 1 factor hierarchical structure as predicted (Figure 4).

Self-efficacy. The 3 factor structure of the situational confidence scale found previously in the focus groups was replicated in the second sample of African-American women. The 12 item instrument was adapted from previous instruments developed in White Americans (S. Rossi, Greene, Reed, J.S. Rossi, Prochaska, & Velicer, 1994) and replicated in a sample of Canadian women (Ounpuu, Woolcott, & Rossi, 1996). The data indicate that African-American women found the self-efficacy construct representing how confident an individual is that she can resist eating high fat foods in three specific situations: positive/social situations, negative/affective situations and difficult situations relevant. The 12 item situational confidence measure instrument was successfully reduced to 9 items. Internal consistency (Alpha) coefficients for the three confidence scales ranged from .82 to .92, mean = .87. The overall 9 item Self-efficacy scale was found to have excellent internal consistency (Alpha = .90). Item means were acceptable. The measurement model (Figure 5) obtained using structural modeling techniques indicated loadings for all three factors were acceptable (range = .73 to .98, mean = .83). Model fit was good (CFI = .92, RMS = .04), indicating that the theoretical model fit the data very well. As with the temptation scale, the correlation between positive social and difficult situations was somewhat higher than desired (.79). Traditionally, items in TTM temptation and confidence scales have been identical. However, in the final version of the confidence scale for African-Americans some items were more acceptable to Black Women and therefore differ. Scale means, standard deviations and alphas are presented in Table 6.

A One factor hierarchical model has been documented in previous TTM studies of self-efficacy in which all three lower order situational factors load on a single higher order factor representing overall confidence. Results provide an additional test of the applicability of the Transtheoretical Model Self-efficacy construct to dietary fat reduction. The 9 item, 3 correlated factors model derived in Study 2 was used as a basis for this analysis. Results revealed a 1 factor hierarchical structure as predicted (Figure 6).

Processes of Change. The Processes of Change construct represents strategies and techniques which individuals engage in during attempts to reduce fat consumption. The construct was found to be relevant to African-American women. Initially plans called for the administration of a 33 item process of change scale to be administered to the previous focus group. This was reduced to 25 items prior to that administration because of time and subject burden restraints imposed on the focus groups. Based on results from Study 1, item revision was indicated for three scales: Stimulus Control, Environmental Reevaluation, and Reinforcement Management.

Since more time was available with the second sample, the original 33 item instrument was administered to the larger sample. Results of Study 2 replicated the 11 process structure (5) suggested in the preliminary results on the first sample and found in White populations. Internal consistency (Alpha) coefficients for the 33 items ranged from .70 to .85 ($M = .78$). All but one item loaded acceptably (Stimulus control .39). When compared to the internal consistency (Alpha) coefficients for the same 22 process items previously obtained from the focus groups, results in this sample were similar (Table 7). Model fit (Figure 7) was good (CFI = .93, RMS = .056), indicating that the theoretical model fit the data well. Loadings were acceptable for all processes and exceeded the .50 criterion (range = .39 to .89, mean = .74) except for a single stimulus control item number 5 which did not load (.33). While failure of a single item to load indicates the item did not measure the construct adequately and could be improved on, replication of the 11 factor measurement was still achieved. Residuals between some factors were found to be high. This is not an uncommon finding with models that involve higher order factors. Scale means, standard deviations and alphas are presented in Table 6.

A two factor hierarchical model (Figure 8) has been documented in previous processes of change studies with some processes loading as experiential and others as behavioral. As higher order factors could explain some of the high residuals, structural modeling techniques were employed to test the measurement model for evidence of hierarchical structure. Results provide an additional test of the applicability of the Transtheoretical Model Process construct to dietary fat reduction. The 33 item, 11 correlated factors model derived in Study 2 was used as a basis for this analysis. Results revealed a 2 factor hierarchical structure of Experiential and Behavioral processes (6). Six primary lower order processes: Consciousness Raising, Dramatic Relief, Self Reevaluation, Self Liberation, Environmental Reevaluation, and Social Liberation loaded on the higher order Experiential factor as expected. Five lower order primary processes: Helping Relationships, Reinforcement Management, Interpersonal Systems Control, Counter Conditioning, and Stimulus Control were found to load on the higher order Behavioral factor as expected. Loadings and the correlation between the two higher order processes were very similar. These results were consistent with Transtheoretical Model predictions of hierarchical process structure.

Social Desirability Analyses. Correlations of the Jackson Social Desirability Scale (Jackson, 1967) with each dietary fat reduction instrument are reported in Table 8. Higher scores represent greater social desirability. No significant correlations were found between the Jackson social desirability scale scores and the majority of TTM measures that were developed. Correlations between the Jackson social desirability scale scores and the Negative Affective scales of both the situational temptation (-.25) and self-efficacy (-.26) measures were significant. However, both scale correlations with social desirability were less than .30. Based on previous Transtheoretical Model investigations, these values were within an acceptable range. Correlations between the Jackson Social Desirability Scale and the Situational Temptation Questionnaire demonstrated that social desirability did not play a substantial role in subjects' responses to that instrument. While these data showed that social desirability played a minimal role in subjects responses to situational temptation

and confidence, these findings also suggest that the dietary fat reduction measures developed in this study were psychometrically sound.

External Validity Analyses

Stage By Process Of Change Relationship. A one way multivariate analysis of variance (MANOVA) was performed on the raw process data to determine if the processes of change for dietary fat reduction varied with Stage of Change. Stage Algorithm 1 was used. The MANOVA was conducted using stage of change as the independent variable and the 11 processes of change as dependent variables. Listwise deletion was used with data from 25 of the 207 subjects excluded due to missing data. This resulted in a total sample size of 182 for this analysis. Subjects consisted of 21 Precontemplators, 33 Contemplators, 31 in Preparation, 51 in Action and 46 in Maintenance. A violation of the assumption of multivariate A violation of Homogeneity of the Dispersion Matrices was detected, however, this was of little concern since the test is well known for being overly sensitive. No violations were found for other assumptions of MANOVA. The MANOVA resulted in a significant main effect for Stage, Wilk's $\Lambda = .49$, $p < .001$, approximate $F [(44,640.85) = 3.00$, multivariate $\eta^2 = .16$, with the processes accounting for 16% of the variance. These results indicate that processes of change vary by stage of change, providing evidence of external validity for the instrument. Follow-up univariate analyses of variance (ANOVA) were conducted on the raw data for the processes of change scales separately to detect group differences between stages. Violations of the assumption of homogeneity of variance was detected for the Processes of dramatic relief, reinforcement management and interpersonal systems control, hence, these ANOVAs were not interpreted. No violations of ANOVA were detected for the other processes of change so follow-up tests were conducted using the harmonic mean.

The one-way analysis of variance performed on the Consciousness Raising (CR) scale was significant, $F (4,177) = 22.17$, $p < .001$, $\eta^2 = .33$, accounting for 33% of the variance. A follow-up Tukey-HSD procedure was conducted to detect where differences lay among the groups. Precontemplators were found to use CR less than Contemplators, subjects in Preparation, Action, or Maintenance. Contemplators were found to use CR less than subjects in Preparation, Action, or Maintenance. A one-way analysis of variance performed on the Self-Reevaluation (SR) scale was significant, $F (4,177) = 20.35$, $p < .001$, $\eta^2 = .32$, accounting for 32% of the variance. A follow-up Tukey-HSD procedure revealed that Precontemplators were found to use SR less than Contemplators, subjects in Preparation, Action, or Maintenance. Contemplators were found to use SR less than subjects in Action, or Maintenance. A one-way analysis of variance performed on the Self-Liberation (SL) scale was significant, $F (4,177) = 20.43$, $p < .001$, $\eta^2 = .32$, accounting for 32% of the variance. A follow-up Tukey-HSD procedure revealed that Precontemplators were found to use SL less than Contemplators, subjects in Preparation, Action, or Maintenance. Contemplators were found to use SL less than Maintenance. The one-way analysis of variance performed on the Environmental Reevaluation (ER) scale was significant, $F (4,177) = 7.25$, $p < .001$, $\eta^2 = .14$, accounting for 14% of the variance. A follow-up Tukey-HSD procedure revealed that Precontemplators were found to use ER less than subjects in Preparation, Action, or Maintenance. Contemplators were found to use ER less than Maintenance. The one-way analysis of variance performed on the Social Liberation (SL) scale was significant, $F (4,177) = 6.42$, $p <$

.001, $\eta^2 = .13$, accounting for 13% of the variance. A follow-up Tukey-HSD procedure revealed that Precontemplators were found to use SO less than subjects in Preparation, Action, or Maintenance. Contemplators were found to use SO less than Maintenance. The one-way analysis of variance performed on the Helping Relationships (HR) scale was significant, $F(4,177) = 4.45$, $p < .01$, $\eta^2 = .9$, accounting for 9% of the variance. The Tukey-HSD procedure revealed that Precontemplators were found to use HR less than Action, or Maintenance. The one-way analysis of variance performed on the Counterconditioning (CC) scale was significant, $F(4,177) = 5.22$, $p < .001$, $\eta^2 = .12$, accounting for 12% of the variance. The Tukey-HSD procedure showed that Precontemplators were found to use CR less than Contemplators, subjects in Preparation, Action, or Maintenance. Contemplators were found to use CR less than subjects in Preparation, Action, or Maintenance. The one-way analysis of variance performed on the Stimulus Control (SC) scale was significant, $F(4,177) = 8.74$, $p < .001$, $\eta^2 = .16$, accounting for 16% of the variance. The Tukey-HSD procedure showed that Precontemplators were found to use SC less than Action, or Maintenance. Contemplators were found to use SC less than subjects in Maintenance. As consistent with previous TTM predictions, results showed that Precontemplators use the processes of change the least and thus provide further support for external validity of the process measure.

A Discriminant Function Analysis (DFA) was performed on the raw data using the Direct method as a follow-up test to the statistically significant MANOVA with the the 11 processes of change for discriminating among the five groups. Three discriminant functions were calculated, with a significant Wilk's $\Lambda = .49$, $p < .001$, combined $\chi^2(44) = 123.98$. However, since none of these functions was significant, the results of the DFA did not illuminate further information about discrimination between groups.

When plotted, an examination of the pattern of the processes of change by stage of change grouping (Figure 9) indicated that process use was fairly linear. That is, with process use increased as stage of change increased. Results are similar to those found with previous dietary fat reduction studies of process use in predominantly White populations. Lowest process use was associated with the Precontemplation stage of change for all eleven processes. Means and standard deviations in T scores for each process of change by stage are presented in Table 9.

Stage By Decisional Balance Relationship. A one way multivariate analysis of variance (MANOVA) was performed on the new 8 item decisional balance data to determine if the pros and of dietary fat reduction varied with Stage of Change. Stage Algorithm 1 was used. The MANOVA was conducted using stage of change as the independent variable and pros and cons of decisional balance as dependent variables. Listwise deletion was used with data from 11 of the 207 subjects excluded due to missing data. This resulted in a total sample size of 196 for this analysis. Subjects consisted of 26 Precontemplators, 32 Contemplators, 31 in Preparation, 54 in Action and 53 Maintenance subjects. No violations of the assumptions for MANOVA were detected.

The MANOVA resulted in a significant main effect for Stage, Wilk's $\Lambda = .83$, $p < .001$, approximate $F(12,119916) = 1.11$, multivariate $\eta^2 = .09$, accounting for only 9% of the variance. These results indicate that pros and cons vary by stage of change, providing evidence of external validity for the instrument. Follow-up univariate analyses of variance (ANOVA) were conducted on the raw data for the pros and cons scales separately to detect group differences between stages. A violation of the assumption of homogeneity of variance was detected for the Pros

so that one-way ANOVA was not interpretable. No violations of ANOVA were detected for the Cons so follow-up tests were conducted using the harmonic mean. The one-way analysis of variance performed on the cons scale was significant, $F(4,191) = 5.57, p < .001, \eta^2 = .10$, accounting for 10% of the variance. A follow-up Tukey-HSD procedure was conducted to detect where differences lay among the groups. As consistent with previous TTM predictions, results showed that early stage subjects (contemplators and subjects in preparation) endorsed higher cons than later stage subjects (Action or Maintenance). These results also provide support for the measure.

A Discriminant Function Analysis (DFA) was performed on the raw decisional balance data using the direct method as a follow-up test to the statistically significant MANOVA. The pros and cons of decisional balance were examined for ability to discriminate among the five groups. As with the previous MANOVA, five levels of stage of change were used (PC,C,P, A,M) via stage algorithm 1. Sample size and stage sample sizes remained the same. Two discriminant functions were calculated, with a significant Wilk's $\Lambda = .83, p < .001$, combined $\chi^2(8) = 35.94$. Only the first function was significant: Wilk's $\Lambda = .95, p < .05, \chi^2(3) = 10.04$. The squared canonical correlation for the single discriminant function was $R^2 = .13$ explaining 13% of variance between the groups. Using a criterion of $\geq .3$ as a cutoff, loadings suggested that function one was associated with both the pros and cons of change. The first discriminant function maximally separated Precontemplators from Contemplators and subjects in Preparation, Contemplators from people in Preparation, and Action and Maintenance subjects. The magnitude of the effects in separating the groups may be interpreted in terms of differences in standard deviation units between group centroids using Cohen's (1988) small (.2), medium (.5) and large (.8) effects. Group Centroids, the ordered structure matrix of the pooled within-groups correlations between the discriminating variables and the significant canonical discriminant function are presented in Table 10. A large effect close to 1 standard deviation (SD) were found for the pros and cons between Precontemplators and Contemplators (.88), Precontemplators and those in Preparation (.91). Medium size effects of just under 3/4 were found for the pros and cons between Contemplators and subjects in Preparation (.71) and over 2/3 between subjects in Action and Maintenance (-.68). An examination of means for the pros and cons of change by stage of change grouping indicated that lower scores were associated with Precontemplation and higher scores associated with Preparation for the pros. For the cons, lower scores were associated with Maintenance and higher scores with Preparation. These results are consistent with TTM predictions of higher cons lower pros for early stage subjects and lower cons, higher pros for later stage subjects.

Means and standard deviations for the Pros and Cons scales in T scores by stage of change are presented in Table 11. As expected, mean endorsement of the Pros and Cons varied by Stage of change. For the purposes of the overall pattern examination and comparison with results from other decisional balance studies across problem areas, raw scores for both the Pros and Cons were converted to standardized T scores ($M = 50, SD = 10$) and plotted for each of the four Stages of Change. When plotted by Stage of Change (Figure 10), the pros and cons for changing behavior to reduce dietary fat consumption followed the basic characteristic pattern (Prochaska, Velicer, Rossi, Goldstein et al., 1994). The cons of dietary fat reduction appear higher than the pros in Precontemplation, are about equivalent at a decisional balance point in Preparation, and reverse so

that the pros appear higher than the cons in Maintenance. These results suggest the measure is externally valid.

Stage By Situational Temptation Relationship. A one way multivariate analysis of variance (MANOVA) was performed on the raw confidence and Temptation data to determine if the Temptation and Situational Self-efficacy scales for dietary fat reduction varied with Stage of Change. Stage Algorithm 1 was used. The MANOVA was conducted using stage of change as the independent variable and dependent variables included overall temptation and confidence. Listwise deletion was used with data from 14 of the 207 subjects excluded due to missing data. This resulted in a total sample size of 193 for this analysis. Subjects consisted of 24 Precontemplators, 33 Contemplators, 33 in Preparation, 54 in Action and 49 Maintenance subjects. A violation of Homogeneity of the Dispersion Matrices was detected, however, this was of little concern since the test is well known for being overly sensitive. No violations of the assumptions for MANOVA were detected.

The overall MANOVA resulted in a significant main effect for stage of change, Wilk's $\Lambda = .90$ $p < .01$, approximate $F(8,374) = 2.53$, multivariate $\eta^2 = .05$, accounting for 5% of the variance. A test of homogeneity of variance for separate ANOVAs conducted as follow-up tests to the MANOVA for overall confidence and temptation did not reveal a violation for overall Temptation. The one-way analysis of variance performed on the overall Temptation was not significant.

Another one way multivariate analysis of variance (MANOVA) was performed on the raw confidence data and Temptation data to determine if the separate situational scales for Temptation and Situational Self-efficacy varied with Stage of Change. The three types of situational temptation and confidence were: positive social situations, negative affective situations, and difficulty in accessing or preparing food. Listwise deletion was used with data from 10 of the 207 subjects excluded due to missing data. This resulted in a total sample size of 197 for this analysis. Subjects consisted of 25 Precontemplators, 34 Contemplators, 32 in Preparation, 56 in Action and 50 Maintenance subjects. A violation of Homogeneity of the Dispersion Matrices was detected. No other violations of the assumptions for MANOVA were detected. The overall MANOVA for temptation on the three separate situational scales was significant, $F(24,653.58) = 1.82$, $\eta^2 = .05$, accounting for 5% of the variance. Follow-up univariate analyses of variance (ANOVA) were also conducted for the three separate temptation scales to detect differences between stages in different situations. No violations of the assumption of homogeneity of variance were detected for any of the temptation scales and all follow-up tests for them were conducted using the harmonic mean of all the groups. The one-way analysis of variance performed on the Positive Social Situations scale for temptation was significant, $F(4,192) = 5.36$, $p < .001$ $\eta^2 = .10$ accounting for 10% of the variance. A follow-up Tukey-HSD test revealed that Precontemplators and subjects in Preparation experienced more temptation in positive social situations than those in subjects in Maintenance. The one-way analyses of variance performed on the Negative Affective scale was barely significant, $F(4,192) = 2.44$, $p < .048$ $\eta^2 = .05$ accounting for 5% of the variance. A follow-up Tukey-HSD showed no differences between the groups. The one-way analyses of variance performed on the Difficulty scale was not significant. The significant MANOVAs indicate the temptation scale has some external validity. In addition, results showing that subjects in the

early stages of change have more temptation than those in the later stages is consistent with previous TTM studies of temptation and provide some external validity for the scale.

A Discriminant Function Analysis (DFA) was performed on the raw Temptation data using the direct method as a follow-up test to the statistically significant MANOVA. The three temptation scales were examined for ability to discriminate among the five groups. Five levels of stage of change were used (PC,C,P, A,M) via stage algorithm 1. Sample size and stage sample sizes remained the same as with the MANOVA. Three discriminant functions were calculated, with a significant Wilk's $\Lambda = .80$, $p < .01$, combined $\chi^2(24) = 43.04$. However, since none of the three functions were significant, the DFA was not useful. A separate DFA performed for overall confidence and temptation was significant, Wilk's $\Lambda = .90$, $p < .01$, combined $\chi^2(8) = 19.85$. However, this analysis also was found to be unhelpful since the single calculated function was not significant.

For the purposes of pattern examination, raw scores for overall temptation were converted to standardized T scores ($M = 50$, $SD = 10$) and plotted by stage of change (Table 12). The pattern of overall Temptation across the stages is presented in Figure 11. Higher temptation in early staged subjects and lower temptation in later stages is consistent with previous TTM studies of temptation (Rossi, 1993, Velicer et al, 1990). Similar temptation scores in Precontemplation and Maintenance subjects have been reported as sample dependent in previous dietary studies (Rossi, 1993).

Stage By Situational Self-Efficacy Relationship. A one way multivariate analysis of variance (MANOVA) was performed on the raw confidence and Temptation data to determine if the Temptation and Situational Self-efficacy scales for dietary fat reduction varied with Stage of Change. Stage Algorithm 1 was used. The MANOVA was conducted using stage of change as the independent variable and dependent variables included overall temptation and confidence. Listwise deletion was used with data from 14 of the 207 subjects excluded due to missing data. This resulted in a total sample size of 193 for this analysis. Subjects consisted of 24 Precontemplators, 33 Contemplators, 33 in Preparation, 54 in Action and 49 Maintenance subjects. A violation of Homogeneity of the Dispersion Matrices was detected, however, this was of little concern since the test is well known for being overly sensitive. No violations of the assumptions for MANOVA were detected.

The overall MANOVA resulted in a significant main effect for stage of change, Wilk's $\Lambda = .90$ $p < .01$, approximate $F(8,374) = 2.53$, multivariate $\eta^2 = .05$, accounting for 5% of the variance. A test of homogeneity of variance for separate ANOVAs conducted as follow-up tests to the MANOVA for overall confidence and temptation revealed a violation for overall Confidence so no further analysis was conducted. The one-way analysis of variance performed on the overall Confidence.

Another one way multivariate analysis of variance (MANOVA) was performed on the raw confidence data and Temptation data to determine if the separate situational scales for Temptation and Situational Self-efficacy varied with Stage of Change. The three types of situational temptation and confidence were: positive social situations, negative affective situations, and difficulty in accessing or preparing food. Listwise deletion was used with data from 10 of the 207 subjects excluded due to missing data. This resulted in a total sample size of 197 for this analysis. Subjects

consisted of 25 Precontemplators, 34 Contemplators, 32 in Preparation, 56 in Action and 50 Maintenance subjects. A violation of Homogeneity of the Dispersion Matrices was detected. No other violations of the assumptions for MANOVA were detected. The overall MANOVA for confidence on the three separate situational scales was significant, $F(24,653.58) = 1.82$, $\eta^2 = .05$, accounting for 5% of the variance. Follow-up univariate analyses of variance (ANOVA) were also conducted for the three separate confidence scales to detect differences between stages in different situations. A violation of the assumption of homogeneity of variance was detected for the Difficulty scale, thus that ANOVA was not interpreted. No violations of ANOVA were detected for the other two scales and all follow-up tests for them were conducted using the harmonic mean of all the groups. The one-way analysis of variance performed on the Positive Social Situations scale was significant, $F(4,192) = 5.96$, $p < .001$, $\eta^2 = .11$ accounting for 11% of the variance. A follow-up Tukey-HSD test revealed that subjects in Maintenance had experienced more confidence in positive social situations than those in Precontemplation or Preparation. A One-way analyses of variance performed on the Negative Affective scale was barely significant, $F(4,192) = 2.39$, $p = .05$, $\eta^2 = .05$ accounting for 5% of the variance. The significant MANOVAs indicate the scale has some external validity. In addition, results showing that subjects in the late stages of change have more self-efficacy than those in the earlier stages is consistent with previous TTM studies of self-efficacy and provide some external validity for the scale.

A Discriminant Function Analysis (DFA) was performed on the raw Confidence data using the direct method as a follow-up test to the statistically significant MANOVA. The three temptation scales were examined for ability to discriminate among the five groups. Five levels of stage of change were used (PC,C,P, A,M) via algorithm 1. Sample size and stage sample sizes remained the same as with the MANOVA. Three discriminant functions were calculated, with a significant Wilk's $\Lambda = .80$, $p < .01$, combined $\chi^2(24) = 43.04$. However, since none of the three functions were significant, the DFA was not useful. A separate DFA performed for overall confidence and temptation was significant, Wilk's $\Lambda = .90$, $p < .01$, combined $\chi^2(8) = 19.85$. However, this analysis also was found to be unhelpful since the single calculated function was not significant.

For the purposes of pattern examination, raw scores for overall confidence were converted to standardized T scores ($M = 50$, $SD = 10$) and plotted by stage of change (Table 13). The pattern of overall Confidence across the stages is presented in Figure 12. These results are consistent with previous TTM findings (Rossi, 1993, Velicer et al, 1990).

References:

- Bollen, K.A. (1989). *Structural equations with latent variables*. New York: Wiley.
- Cohen, J. (1988). *Statistical power analysis for the behavioral sciences* (2nd ed.). Hillsdale, NJ: Lawrence Erlbaum.
- Curry, S.J., Kristal, A.R., & Bowen, D.J. (1992). An application of the stage model of behavior Change to dietary fat reduction. *Health Education Research: Theory & Practice*, 7, 95-105.
- Dwyer, J.H. (1983). *Statistical models for the social and behavioral sciences*. New York: Oxford University Press.
- Fava, J.L., Velicer, W.F., & Rossi, J.S. (1995, March). *Procedures for developing quality measures*. Paper presented at the 16th annual conference of the Society of Behavioral Medicine, San Diego, CA.
- Greene, G.W., Rossi, S.R., Reed, G.R., Willey, C. Prochaska, J.O. (1994). Stages of change for reducing dietary fat to 30% of energy or less. *Journal of the American Dietetic Association*, 94:1105-1110.
- Horn, J.L. (1965). A rationale and test for the number of factors in factor analysis. *Psychometrika*, 30, 179-185.
- Jackson, D.N., (1967). *Personality Research Form*. Port Huron, MI: Research Psychologists Press.
- Jackson, D.N. (1970). A sequential system for personalty scale development. In C.C. Spielberger (Ed.), *Current topics in clinical and community psychology*, (Vol. 2, pp. 61-96). New York: Academic Press.
- Jackson, D.N. (1971). The dynamics of structured personality tests. *Psychological Review*, 78, 229-248.
- Kristal, A.R., Shattuck, A.L., Henry, A.J., & Fowler, A.S., (1990). Rapid assessment of dietary intake of fat, fiber, and saturated fat. Validity of an instrument suitable for community intervention research and nutritional surveillance. *American Journal of Health Promotion*, 4, 288-295.
- Long, J.S. (1983). *Confirmatory factor analysis: A preface to LISREL*. Newbury Park, CA: Sage.
- Ounpuu, S., Woolcott, D.M., & Rossi, S.R. (1996, May). *Validation of a situational self-efficacy scale for dietary fat reduction*. Paper presented at the Annual Meeting of the Canadian Dietetic Association, Banff, Canada.
- Prochaska, J.O., Velicer, W.F., Rossi, J.S., Goldstein, M.G., Marcus, B.H., Rakowski, W., Fiore, C., Harlow, L.L., Redding, C.A., Rosenbloom, D., & Rossi, S.R. (1994). Stages of change and decisional balance for 12 problem behaviors. *Health Psychology*, 13, 39-46.
- Rossi, S.R. (1993). *Application of the Transtheoretical Model of Behavior Change to dietary fat reduction in a naturalistic environment*. Unpublished doctoral dissertation. University of Rhode Island.
- Rossi, S.R., Rossi, J.S., Prochaska, J.O., & Velicer, W.F. (1993, August). Measurement structure of a decisional balance questionnaire for dietary fat reduction. Paper presented at the 101st annual convention of the American Psychological Association, Toronto, Ontario, Canada.

- Velicer, W.F., DiClemente, C.C., Rossi, J.S., & Prochaska, J.O. (1990). Relapse situations and self-efficacy: An integrative model. *Addictive Behaviors, 15*, 271-283.
- Zwick, W.R. & Velicer, W.F. (1986). Comparison of five rules for determining the number of components to retain. *Psychological Bulletin, 99*, 432-442.

Table 1

Stage of Change Using Algorithm 1 (Belief & Intention Criterion Alone)

Stage	N	%
Precontemplation	26	12.6
Contemplation	34	16.4
Preparation	33	15.9
Action	58	28.0
Maintenance	56	27.1

Table 2

Stage of Change Using Algorithm 2 (30% Criterion)

Stage	N	%
Precontemplation	30	14.7
Contemplation	73	13.8
Preparation	86	42.2
Action	6	2.9
Maintenance	9	4.4

Table 3

Stage of Change Using Algorithm 2 (25% Criterion)

Stage	N	%
Precontemplation	30	14.8
Contemplation	76	37.4
Preparation	95	46.8
Action	1	0.5
Maintenance	1	0.5

Table 4

Principle Component Factor Loadings for 16 Decisional Balance Item Scale

Scale Designation	Item	Factor Loading	Factor Loading
Con	09	.76	
Con	05	.72	
Con	03	.71	
Con	15	.69	
Con	01	.66	
Con	13	.62	
Con	11	.60	
Con	07	.57	.33
Pro	14		.76
Pro	12		.73
Pro	10		.73
Pro	16		.72
Pro	08		.62
Pro	06		.61
Pro	04		.60
Pro	02		.54

N = 182

r = .28

PVA = 48%

Table 5

New 8 item Pros and Cons Scale

Scale	Item	Description
Con	09	High fat foods taste better.
Pro	10	I would be healthier if I ate less fat.
Con	11	Lower fat foods just don't have the flavor I'm used to.
Pro	12	I'd have fewer health risks if I ate lower fat foods.
Con	13	Cutting down on fat involves giving up family traditions.
Pro	14	I might live longer if I adopted lower fat eating habits.
Con	15	Eating lower fat foods would be too stressful right now.
Pro	16	Eating lower fat foods would help me control my weight.

Table 6

Scale Means, Standard Deviations and Alphas for Study Two Transtheoretical Based Dietary Fat Reduction Instruments

Scale	N	Mean	SD	Alpha
<u>Decisional Balance</u>				
Pros	204	4.08	0.96	.82
Cons	197	2.38	0.93	.74
<u>Processes of Change</u>				
Consciousness Raising	202	3.24	1.03	.85
Dramatic Relief	200	2.40	1.04	.79
Self Reevaluation	206	3.54	0.97	.84
Self Liberation	200	3.37	1.03	.85
Environmental Reevaluation	206	3.08	1.14	.85
Social Liberation	205	3.45	0.86	.74
Helping Relationships	194	2.68	1.03	.79
Reinforcement Management	199	2.17	0.91	.70
Interpersonal Relationships	201	1.80	0.84	.79
Counterconditioning	200	2.44	1.02	.80
Stimulus Control	201	2.47	0.88	.80
<u>Temptation</u>				
Overall Temptation	199	2.71	0.91	.89
Positive Social Situations	204	2.93	1.01	.78
Negative Affective Situations	203	2.38	1.24	.92
Difficult Situations	202	2.81	1.02	.85
<u>Self-Efficacy</u>				
Overall Confidence	199	2.10	0.53	.90
Positive Social Situations	206	2.17	0.64	.87
Negative Affective Situations	200	1.94	0.63	.92
Difficult Situations	204	2.21	0.64	.82

Table 7

 Comparison of Processes of Change Internal Consistency Analyses(Coefficient Alpha)

2 Item Process of Change	Alpha		Alpha
	African-American Women Focus Groups	Sample2	Whites
Consciousness Raising	.84	.77	.65
Dramatic Relief	.76	.79	.72
Self-Reevaluation	.91	.83	.82
Self-Liberation	.86	.81	.81
Social Liberation	.78	.64	.70
Environmental Reevaluation	.64	.68	.77
Helping Relationships	.87	.69	.50
Reinforcement Management	.47	.63	.74
Interpersonal Systems Control	.82	.74	.69
Counterconditioning	.84	.82	.64
Stimulus Control	.61	.48	.61

Table 8

Correlations of the Transtheoretical Model Based Measures Developed and Social Desirability

TTM Based Scales	JDS Sample2	JDS Whites
<u>Decisional Balance</u>		
Pros	-.081	-.284
Cons	-.221	-.257
<u>Processes of Change</u>		
Consciousness Raising	.067	.014
Dramatic Relief	-.054	-.228
Self Reevaluation	.048	.053
Self Liberation	.109	.064
Environmental Reevaluation	.030	.046
Social Liberation	.082	.064
Helping Relationships	.074	-.215
Reinforcement Management	-.122	-.203
Interpersonal Relationships	-.006	-.100
Counterconditioning	-.095	-.045
Stimulus Control	-.061	-.076
<u>Temptation</u>		
Positive Social Situations	-.199	-.140
Negative Affective Situations	.252	-.133
Difficult Situations	-.128	-.084
<u>Self-Efficacy</u>		
Positive Social Situations	-.127	
Negative Affective Situations	.262	
Difficult Situations	-.127	

JDS = Jackson Desirability Scale

Table 9

Means and Standard Deviations in T Scores for the Processes By Stage of Change

Stage	PC		C		P		A		M	
	Process Mean	SD	Mean	SD	Mean	SD	Mean	SD		
CR	36.75	7.79	46.86	9.09	50.87	7.70	52.09	8.28	55.77	7.90
DR	44.00	7.71	51.10	10.42	52.21	9.90	49.80	8.61	51.16	11.30
SR	37.00	8.44	46.32	9.71	51.16	8.16	52.21	6.61	55.38	8.24
SL	36.84	8.52	47.38	9.46	50.08	7.89	51.89	7.46	55.55	8.79
ER	43.03	10.02	46.82	8.38	49.57	9.40	51.67	9.13	53.76	10.12
SO	43.29	12.11	46.59	10.85	50.74	9.26	50.83	8.41	54.00	8.19
HR	44.35	9.24	46.94	9.66	50.89	9.96	52.26	9.49	51.69	9.99
RM	46.53	9.20	50.09	9.64	51.94	10.14	50.55	9.66	49.77	10.77
IP	44.65	6.98	49.49	10.48	50.72	9.00	50.91	10.51	51.42	10.42
CC	41.64	8.06	49.77	9.11	52.78	7.96	52.10	8.39	50.18	12.03
SC	41.65	8.83	46.71	9.42	48.95	7.31	52.34	8.46	54.46	10.79

SD = Standard Deviation

PC = Precontemplation

C = Contemplation

P = Preparation

A = Action

M = Maintenance

Table 10

The Group Centroids and Ordered Structure Matrix of the Pooled Within-Groups Correlations Between the Discriminating Variables and the Significant Canonical Discriminant Function for the Pros and Cons.

Group Centroids

Ordered Structure Matrix

<u>Group</u>	<u>Stage</u>	<u>Function 1</u>		<u>Function 1</u>
1	PC	0.54	<u>Pros</u>	-0.34
3	P	0.37	<u>Cons</u>	0.83
2	C	0.34		
4	A	-0.34		
5	M	-0.34		

SD = Standard Deviation

PC = Precontemplation

C = Contemplation

P = Preparation

A = Action

M = Maintenance

Table 11

Means and Standard Deviations in T Scores for the Pros and Cons By Stage of Change

Stage	N	Pros		N	Cons	
		Mean	SD		Mean	SD
PC	26	43.90	9.54	26	51.84	11.33
C	33	50.37	8.92	32	53.93	9.68
P	33	51.16	7.42	31	54.80	9.69
A	57	51.28	8.25	55	47.05	8.95
M	55	50.65	11.54	53	46.99	10.50

SD = Standard Deviation

PC = Precontemplation

C = Contemplation

P = Preparation

A = Action

M = Maintenance

Table 12

Means and Standard Deviations in T Scores for Situational Temptation By Stage of Change

Stage	PC		C		P		A		M	
	Mean	SD	Mean	SD	Mean	SD	Mean	SD	Mean	SD
Temp	48.05	10.75	52.40	10.15	52.14	7.09	50.28	9.32	47.80	11.36
Pos/Soc	50.79	10.60	52.77	9.88	52.57	7.80	49.90	9.18	46.52	11.00
Neg/Aff	47.23	9.92	52.67	10.84	50.81	8.84	50.31	9.13	48.19	10.84
Diff	47.30	12.12	51.55	10.22	52.14	7.28	50.32	9.62	48.74	10.47

SD = Standard Deviation

PC = Precontemplation

C = Contemplation

P = Preparation

A = Action

M = Maintenance

Temp = Overall Temptation

Pos/Soc = Positive Social Situations

Neg/Aff = Negative Affective Situations

Diff = Difficult Situations

Table 13

Means and Standard Deviations in T Scores for Situational Self-Efficacy By Stage of Change

Stage	PC		C		P		A		M	
	Mean	SD	Mean	SD	Mean	SD	Mean	SD	Mean	SD
Conf	44.99	12.04	49.51	8.91	53.65	8.33	52.32	9.55	47.77	9.87
Pos/Soc	45.14	10.94	48.72	9.36	51.92	8.90	52.38	9.56	50.47	10.49
Neg/Aff	47.39	10.53	49.58	10.10	52.74	9.67	52.19	10.13	47.36	9.00
Diff	44.98	11.81	50.37	9.28	54.30	8.10	52.32	9.55	47.44	9.80

SD = Standard Deviation

PC = Precontemplation

C = Contemplation

P = Preparation

A = Action

M = Maintenance

Conf = Overall Confidence/Self-efficacy

Pos/Soc = Positive Social Situations

Neg/Aff = Negative Affective Situations

Diff = Difficult Situations

Figure 1

MEHARRY CONFIRMATORY OLD
DECISIONAL BALANCE 2 FACTOR MODEL

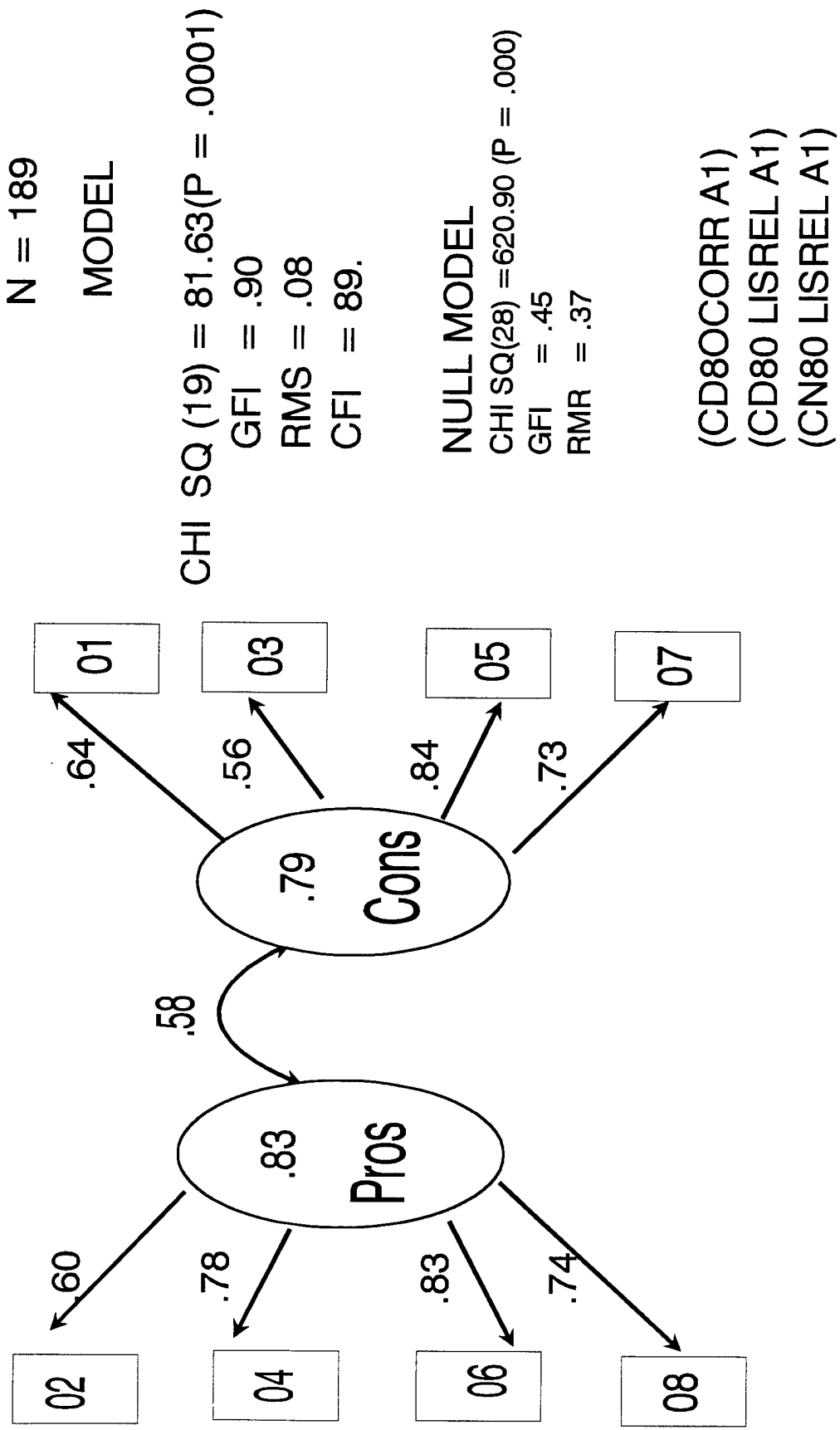

Figure 2

MEHARRY CONFIRMATORY NEW
DECISIONAL BALANCE 2 FACTOR MODEL

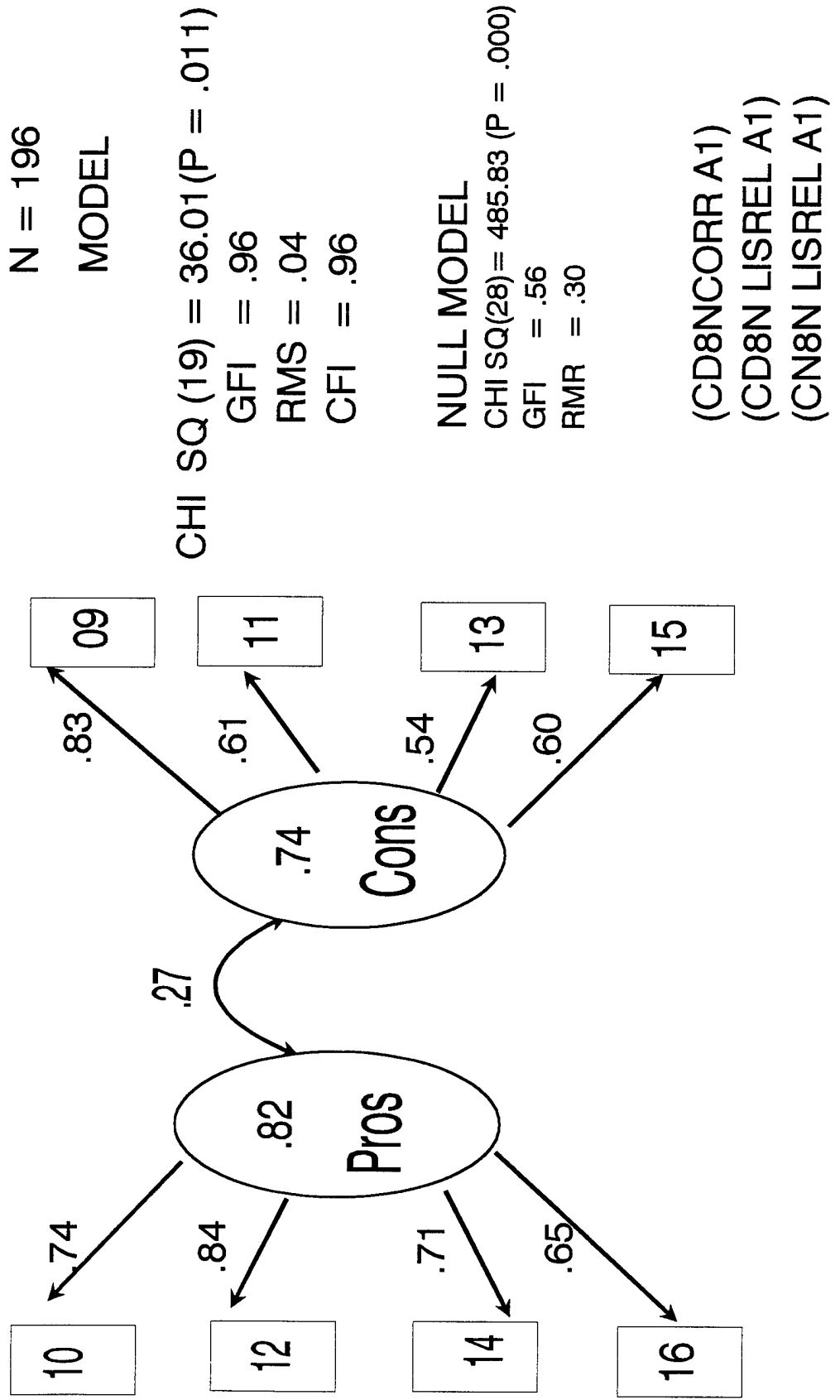
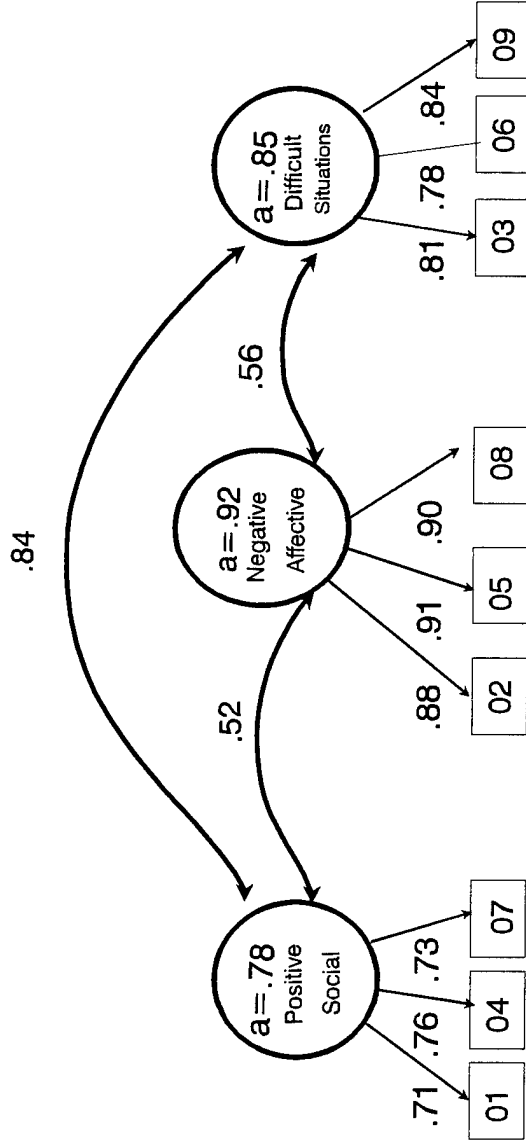

Figure 3
 Situational Temptation Model For Dietary Fat Reduction
 in African-American Women: Sample 2



CHI SQ (24) = 45.56 (p=.005)

GFI = .91

CFI = .98

RMS = .03

9 item a = .89

Null Model

CHI SQ (36) = 1111.09 (p=.000)

GFI = .334

RMS = .447

conf9c.prs

Figure 4
Hierarchical Model of Temptation
African-American Women Sample 2

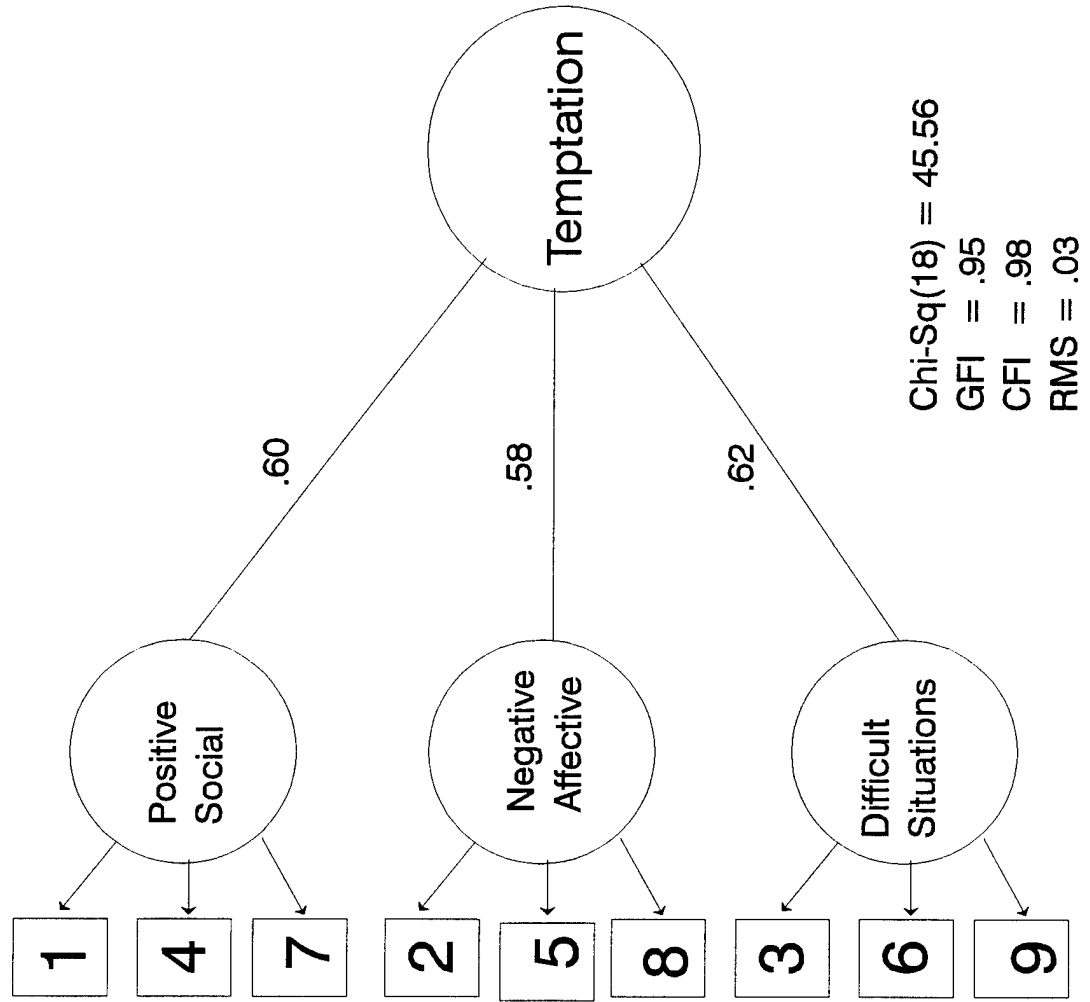

Chi-Sq(18) = 45.56
 GFI = .95
 CFI = .98
 RMS = .03

Null Model
 Chi-Sq(36) = 11184.12
 GFI = .32
 RMS = .46

Figure 5
Hierarchical Model of Confidence
African-American Women Sample 2

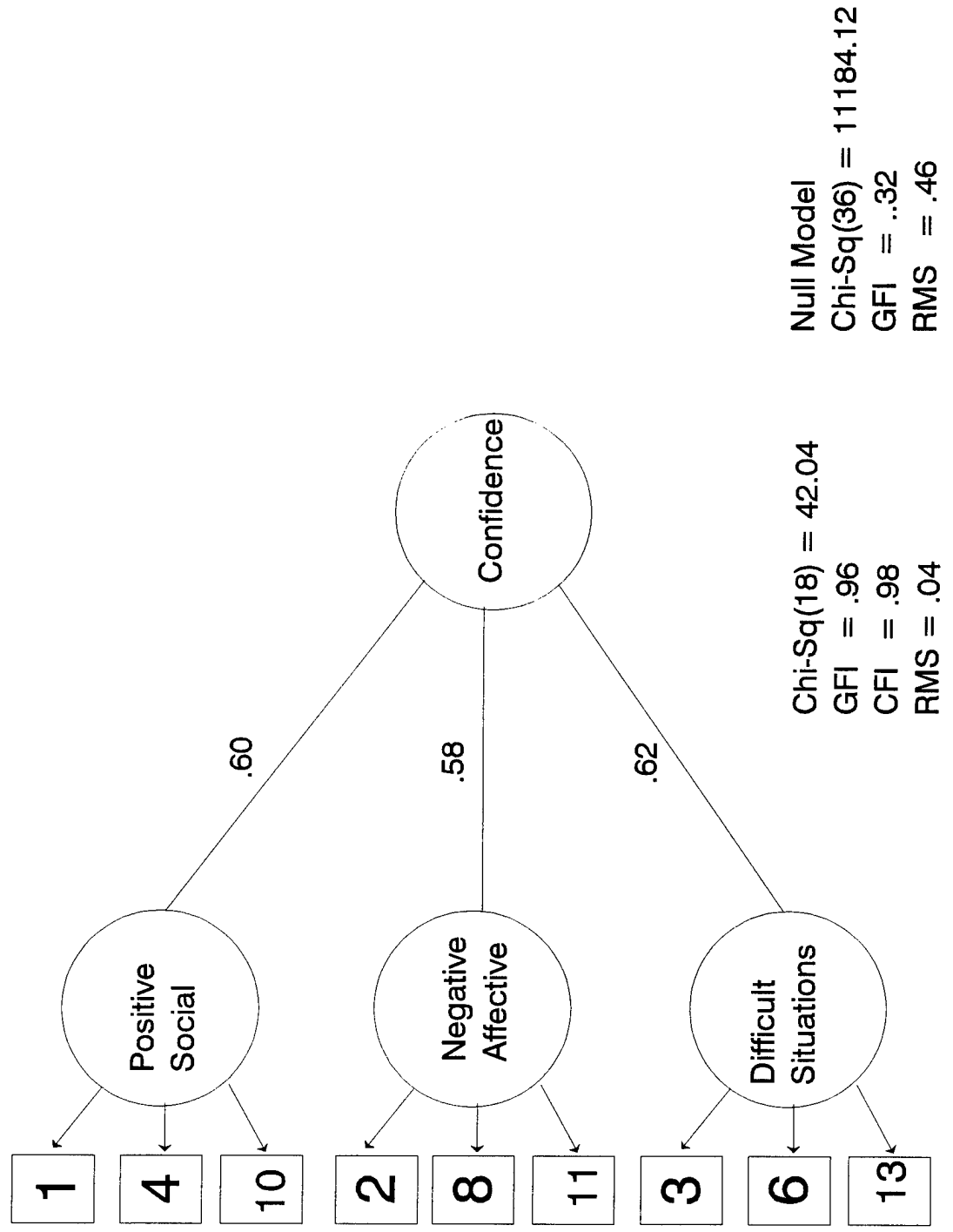
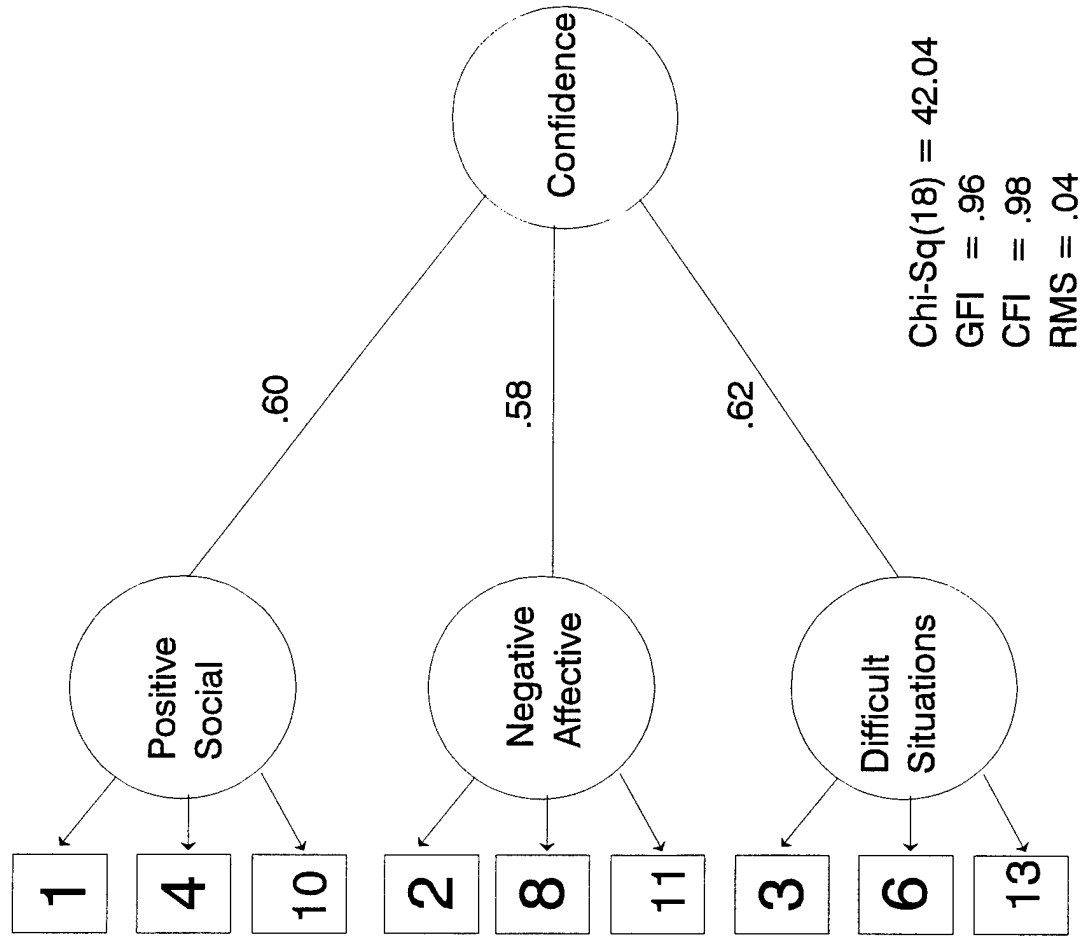

Figure 6
Hierarchical Model of Confidence
African-American Women Sample 2



Chi-Sq(18) = 42.04
 GFI = .96
 CFI = .98
 RMS = .04

Null Model
 Chi-Sq(36) = 11184.12
 GFI = .32
 RMS = .46

Figure 7
Processes of Change for Dietary Fat Reduction
In African American Women: Sample 2

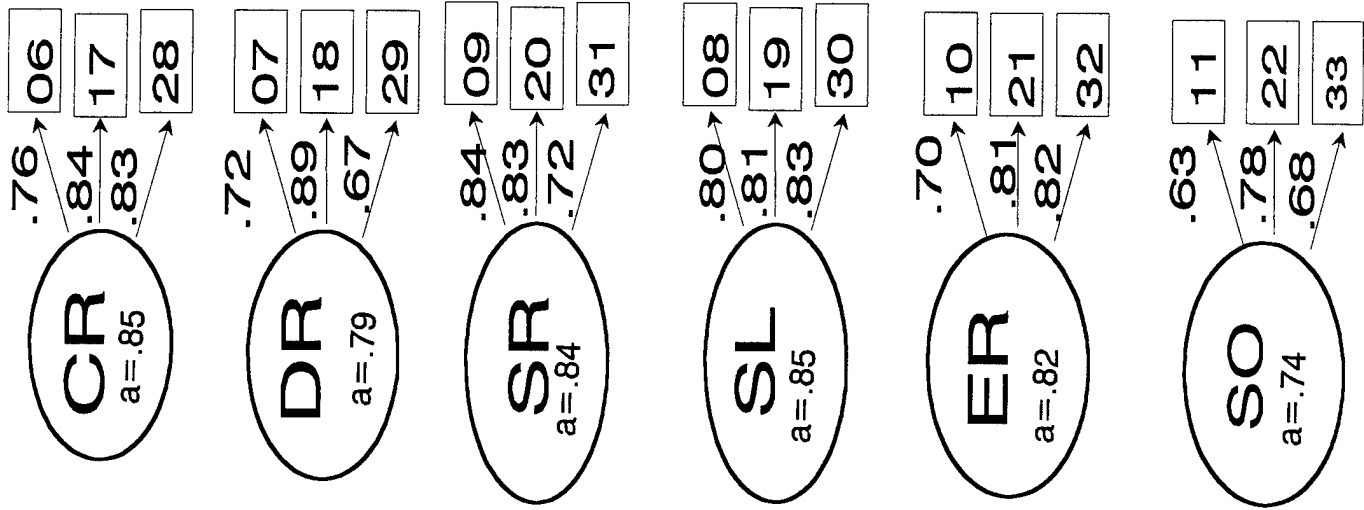

MODEL
CHI SQ(440) = 664.87 ($p = .000$)
GFI = .82
RMS = .056
CFI = .93

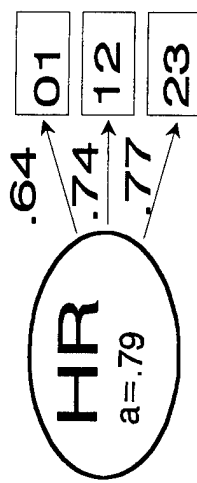

N = 182

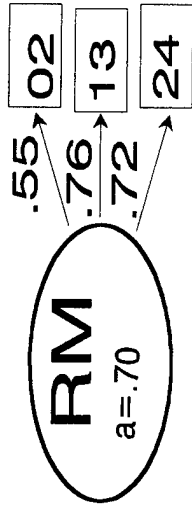

NULL MODEL

CHI SQ(528) = 3669.74 ($p = .000$)
GFI = .199
RMS = .34

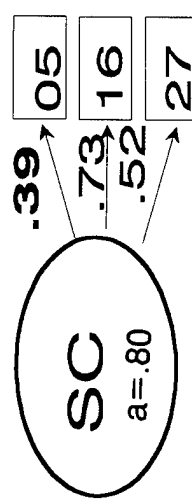
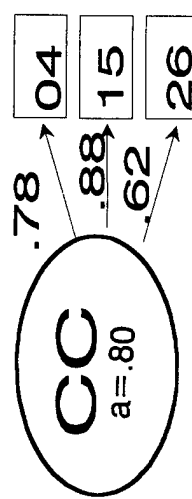
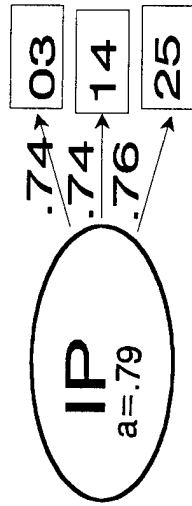

(CPOCL33 CORR A1)
(CPOCL33 LISREL A1)

Figure 8
Hierarchical Process of Change Model For Sample Two

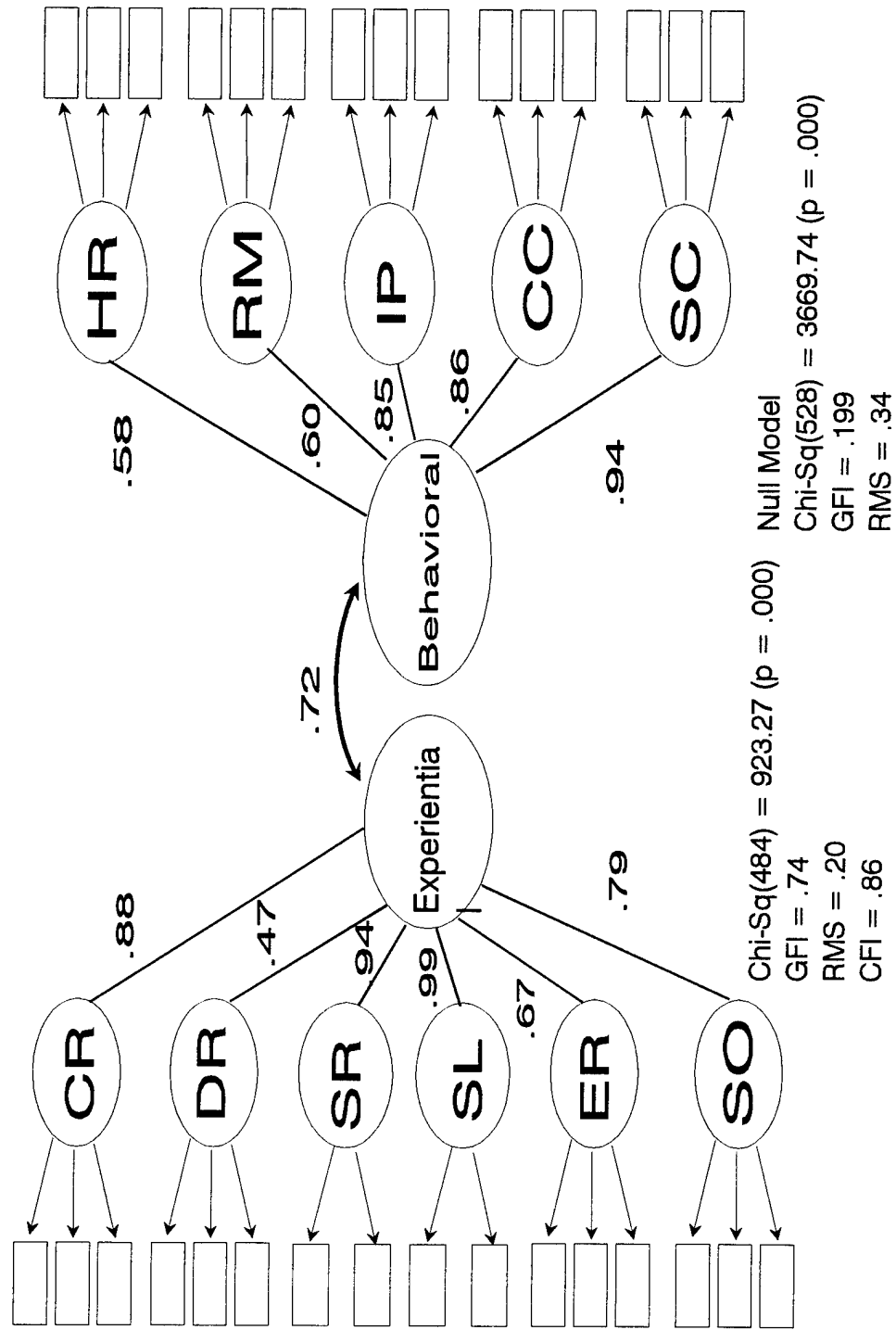

Figure 9
Processes of Change Use By Stage For African-American
Women Sample 2

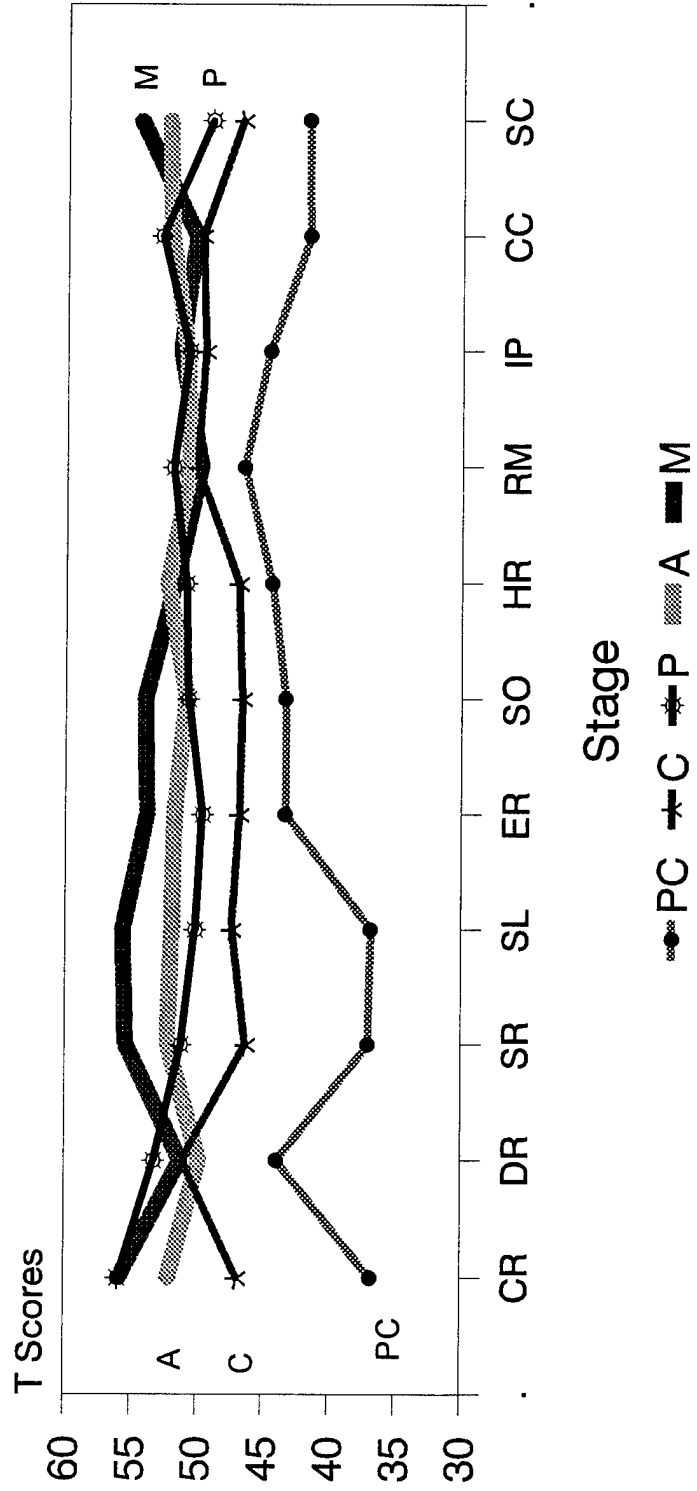

Figure 10
 Decisional Balance
 Pros And Cons Of Reducing Dietary Fat for African-American Women Sample Two

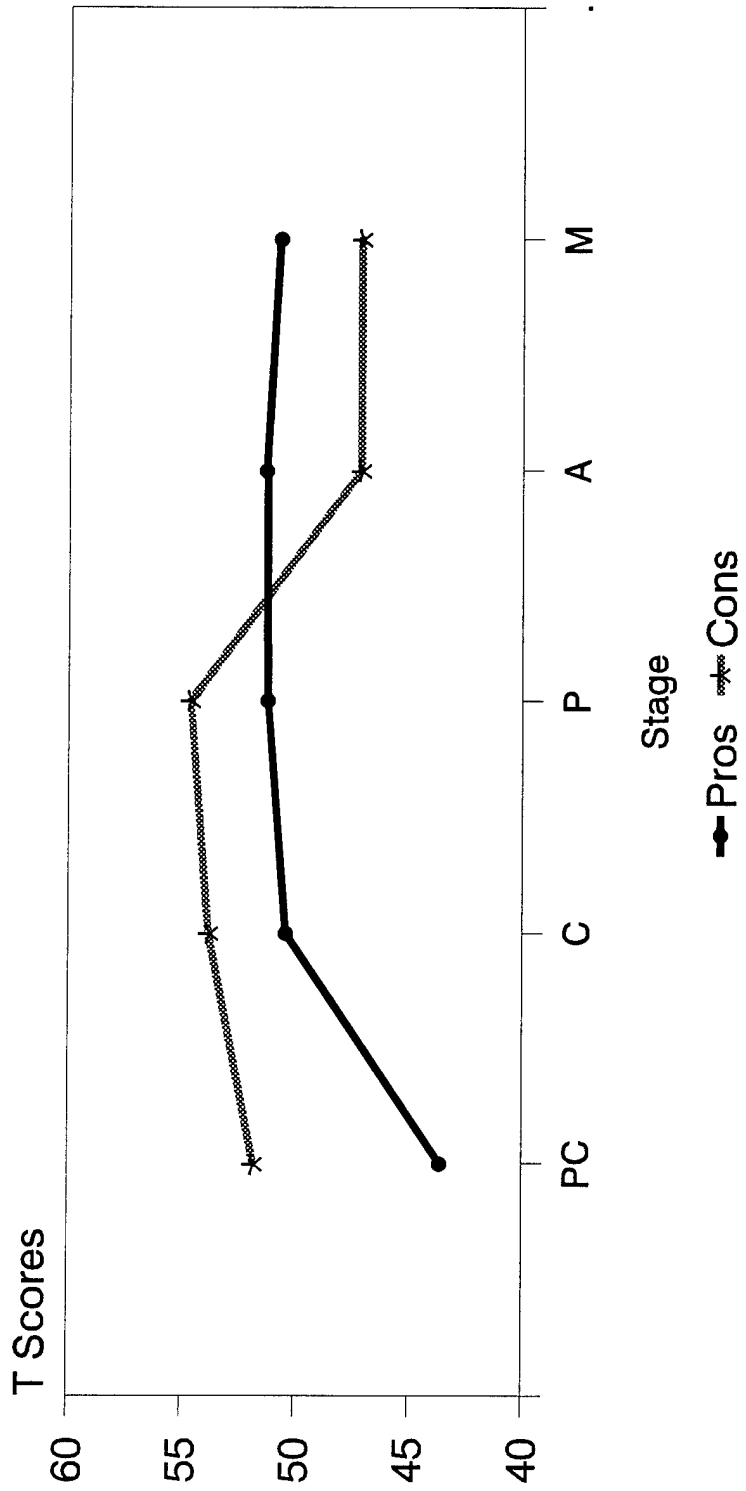
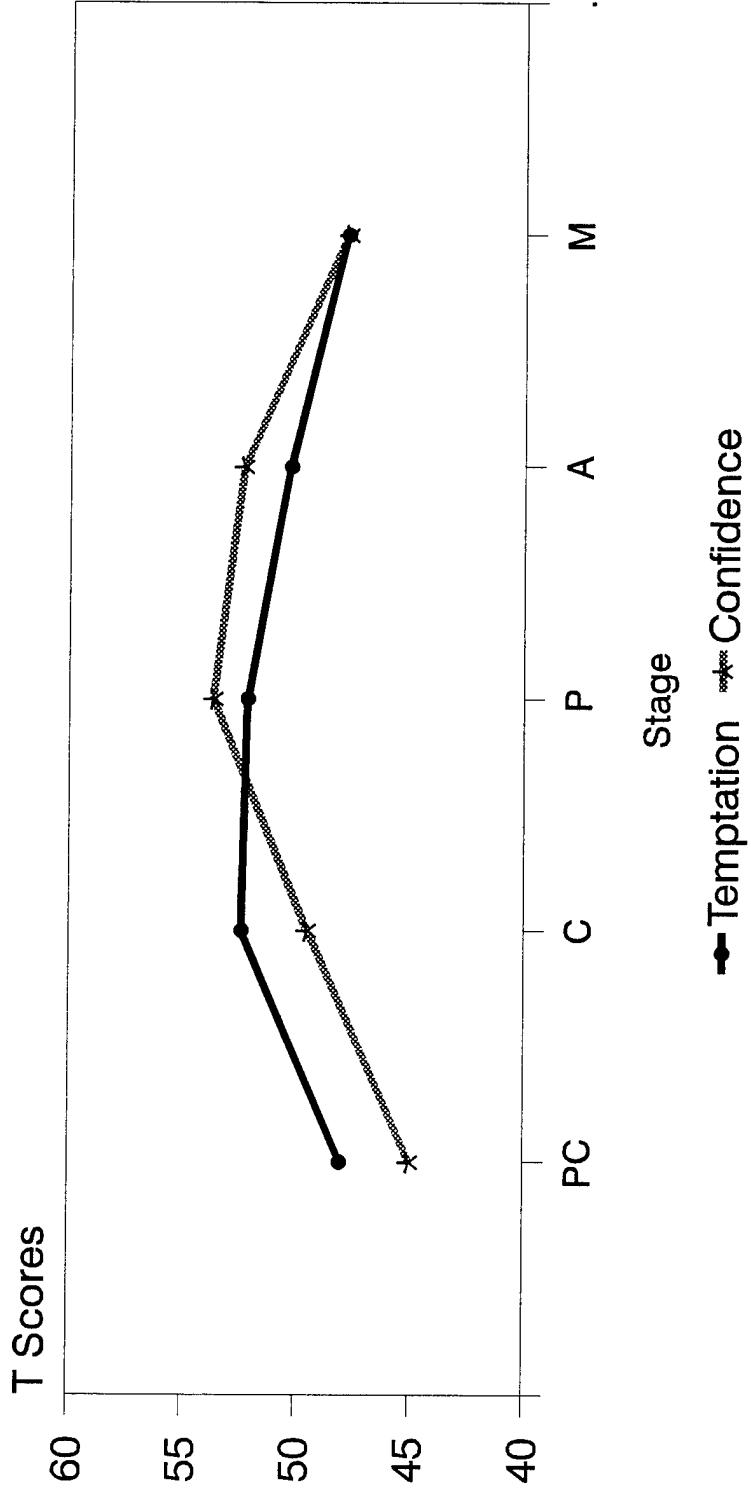

Figure 11
Two
Situational Temptation and Confidence for African-American Women Sample



**B . STAGES OF CHANGE AND THE
INTAKE OF DIETARY FAT IN
AFRICAN AMERICAN WOMEN**

Purpose

Many epidemiological studies have linked the consumption of high fat diets with increased risk of chronic illness (1-2). High fat diets have been linked to an increased risk of heart disease, breast cancer, prostate cancer, colon cancer, and adult onset diabetes (3). The Healthy People 2000 goals include a reduction in dietary fat intake to 30% of calories from fat (3). There is evidence that people would benefit from even more dramatic reductions in their fat intake (4).

The National Cancer Institute, estimated that "...at a minimum, 30,000 lives could be saved by the year 2,000 if Americans would modify their dietary habits" (5). Recent reports indicate that African Americans have a high burden for cancers of the breast, colon, and prostate (6), and preferentially select high fat, low fiber diets (6). When compared with whites, black Americans (cumulative to age 70 years, 1979-81 data), suffered 8,118 excess deaths from cancer (7). Additionally, they suffered 20,335 excess deaths from other chronic diseases (heart disease/stroke, diabetes) for which dietary guidelines also emphasize low-fat/high-fiber intakes (7).

While the public seems to be generally aware of the need to reduce fat intake, surveillance data suggests that only modest declines in fat intake have occurred over the past 20 years and that considerable change will have to occur if the Healthy People 2000 goals are to be met (3,8). The problem of reducing fat intake in the American population in general, and in African Americans in particular, is a matter of getting large numbers of people to make a permanent commitment to changing their eating habits (9). Considerable research on eating behavior suggests that getting people to make permanent changes will be difficult and may require much stronger measures than educational campaigns (1, 10-12).

In addressing the problem of behavior change, psychologists have developed a number of theories which have proven useful both in understanding the process of change and in facilitating the creation of change (13-14). The Transtheoretical model was developed to describe the process of change that occurs in psychotherapy and has subsequently been used to study changes in health behaviors like smoking and alcohol consumption (15-20). The model describes five stages people must pass through in making permanent behavior changes: precontemplation (no intention to change), contemplation (seriously considering change), preparation (taking steps to change), action (actively involved in meaningful change), and maintenance (maintaining meaningful change). The model also proposes that at each stage, different processes are involved in moving the individual to the next stage. The processes include self-efficacy, decisional balance, and change strategies. There is a large body of research supporting the applicability of the Transtheoretical model to a wide range of behaviors (21).

At first glance, it might appear that this model could be easily applied to understanding how people change their eating behavior. Bowen et al (22) developed questionnaires to identify individuals stage of change and to assess the change processes for adopting a low-fat diet. However, unlike smoking, one's eating habits consist of many different behaviors in a wide range of situations. It would be useful to know how an individual's stage of change relates to actual dietary fat intake, and which behaviors people must change in order to reduce their fat intake.

The present studies were undertaken to examine the relationship between stages of change for a low-fat diet, dietary fat intake, and eating behaviors in African American Women. The studies goals were to examine the kinds of changes made by women who described themselves as being in the action and maintenance stage, and to compare the eating habits of these women to

those in the precontemplation, contemplation, and preparation stages. Specifically, we were interested in learning how to most effectively apply the transtheoretical model to the modification of dietary fat intake.

Procedures

Study 1

In study 1, we examined the applicability of the stages of change model to dietary fat intake and used these data to describe the relationships between dietary behaviors, dietary fat intake, and stage of change.

Method

Subjects

The target population for this study was working class and middle income African American women in Nashville, Tennessee. Lists of eligible women were obtained from historically-black Universities, sororities, and senior citizens homes. In addition, contacts were established with predominantly black churches and women who participated in this study were drawn from this population.

Subjects were contacted in a variety of ways. At Meharry Medical College, questionnaire packets were distributed to female employees with their paychecks and they were asked to complete the packets and return them via campus mail. At the senior centers, questionnaires were distributed to potential participants in person during a group activity.

The sample consisted of 174 women, out of 1,972 who were given questionnaires, from whom completed questionnaires were obtained. The mean age was 44.5 (S.D. 14.8). The average number of years of education was 15.9 years (S.D. 3.1). Annual salary was reported by 154 of the women with 43% making less than \$20,000 a year, 32% making between \$20,000 and \$30,000 per year, 14% making between \$40,000 and \$50,000 a year, and 3% making over \$50,000 per year. Seventeen percent had a high school education or less, 46% had gone to college, and 36% had gone to graduate school. On the whole, this sample is one of well-educated, middle-aged, middle-income African American women.

Assessment Instruments

The questionnaire packet consisted of three instruments. The first was a brief demographic questionnaire that asked about age, place of employment, education, and income. The second was Dietary Quick Screen Questionnaire (23). This questionnaire can be used to estimate percent of calories from fat and usual daily intake of dietary fiber and has been used in epidemiological studies of dietary intake. It consists of a list of twenty foods which the subject is asked if they have consumed at least 5 times a week during the last year. A second list of 30 foods is presented, and subjects are asked to indicate which foods have been consumed at least once a week during the previous year. Three additional questions about trimming the fat on meat, consumption of red meat, and use of butter and margarine are also part of the Quick Screen Questionnaire. The scoring of the instrument is based on age-specific regression models, and these models were applied to calculate percent of calories from fat and typical daily fiber intake in grams for each of the 174 participants.

The third questionnaire assessed subject's stage of change using the following item:

I need to have your honest opinion about change in your fat intake. Do you ALMOST ALWAYS avoid eating high fat foods? [e.g., butter, margarine, oil, salad dressing, fat meat, fried food, ice cream]

1. NO and I do NOT intend to in the next 6 months
2. NO, but I intend to in the next 6 months
3. No, but I intend to in the next 30 days
4. YES, and I have been, but for LESS than 6 months
5. YES, and I have been for MORE than 6 months

Subjects answering 1 were classified as precontemplation, 2 as contemplation, 3 as preparation, 4 as action, and 5 as maintenance. This question was modeled after questions used in many studies of the transtheoretical model (21).

Results

Stage of Change

Figure 1 displays the assignment of subjects to the five change stages of the transtheoretical model. Fifty-nine percent of the subjects were in the action or maintenance phases. Stage of change was examined as a function of age (over or under 45) and there was a significant association between age and stage of change (Chi Square = 9.24, $df = 4$, $p < .05$). Younger women were more likely to be in the precontemplation, contemplation, or preparation stages than older women while there was no association between age and being in the action phase but older women were much more likely to be in the maintenance phase. There was no association between education or income and stage of change.

Fat and Fiber Intake

Table 1 presents the means and standard deviations of fat and fiber intake overall, by age, by education, and by income. Age, income, and education were analyzed using one-way analysis of variance, and the only variable significantly associated with fat intake was age. Older women (over 45) reported consuming significantly less fat than younger women. There were no significant associations between the independent variables and fiber intake.

Fat and Fiber Intake by Stage of Change

Table 2 presents the means and standard deviations of fat and fiber intake by stage of change. Fat and fiber were analyzed separately using a one-way analysis of variance. There was a significant difference between fat intake by stage, but no difference in fiber consumption. Using the Tukey Honestly Significant Difference comparison, stages 1-3 did not differ from each other, stages 4 and 5 did not differ, but 1-3 differed significantly from 4 and 5. These data show that the Transtheoretical model, as predicted, shows differences in fat intake between those trying to change (stages 4 and 5) and those not trying to change (stages 1-3).

Discrepancy between self-perception and behaviors

The value of 30% of calories from fat was selected as a cutoff to define two subject groups. This value was selected because it is the national target for fat intake reduction specified in the healthy people 2000 goals (3). Subjects reporting less than 30% of calories from fat were classified as compliant with a low fat diet while subjects consuming more than 30% of calories from fat were classified as consuming a high fat diet. Table 3 presents dietary compliance as a function of stage of change. Ideally, subjects in stages 1-3 should be on high fat diet. The data

clearly confirm this expectation. There were no subjects in stages 1-3 whose fat intake was below 30%. Ideally, subjects in stages 4 and 5 (action and maintenance) should be on low fat diets. The data show that compliance is poor. In the action phase, only 19% of subjects reported fat intakes of less than 30% of calories. Those in the maintenance phase showed better compliance than the action stage. However, 64% of the people who claimed to be in the maintenance phase had fat intakes above 30% of calories. These data clearly indicate that an individual's report of following a low fat diet may not correspond very well to their eating behavior. Overall, there is a difference in the level of fat intake between stages 1-3 and stages 4-5. However, the difference is not clinically significant in that the vast majority of subjects in stages 4-5 are above the level of fat recommended by the healthy persons 2000 goals.

Descriptive Analysis of Patterns of Eating Behavior

To investigate the extent to which dietary fat intake represents a single behavior versus several independent sets of behaviors, the Dietary Quick Screen Questionnaire data were analyzed using hierarchical cluster analysis. The quick screen questionnaire consists of 50 items with each item being endorsed as yes or no by each subject. A squared Euclidian distance matrix was computed, and the cluster analysis was performed using Ward's method. The resulting dendrogram is displayed in Figure 2. Fourteen clusters or groups of food were identified. An average score was calculated across the variables in each cluster. The average scores represent the proportion of time the foods in each cluster were endorsed as eaten, with a low number showing that the foods were rarely eaten, and a high number indicating many subjects reported eating that food. The overall means for each of the foods are included in Figure 2.

Three groups of subjects were formed for further comparison. One group (n=71), labeled not trying, were the subjects in stages 1-3 (precontemplation, contemplation, preparation). The second group (n=73), labeled unsuccessful, consisted of subjects in stages 4 and 5 (action, maintenance) who were consuming more than 30% of their calories from fat. The third group (n=30), labeled successful, were subjects in stages 4 and 5 who consumed fewer than 30% of their calories from fat. One-way analysis of variance was used to compare the three groups on each of the 14 cluster scores. Pair-wise comparisons were made and significance was determined using the Tukey honestly significant difference test. The results are presented in Table 4.

On three of the scales -- eating out, snack foods, and meats -- all three groups differed from each other. The successful subjects consumed less than the unsuccessful subjects who consumed less than the not trying subjects. For chicken and daily fats, the successful subjects consumed less of these foods than either the unsuccessful or not trying subjects who did not differ from each other. The successful subjects consumed more low fat products, breakfast foods, and fruits than the unsuccessful and not trying subjects. For vegetables the successful subjects consumed more than the not trying subjects, while the successful subjects consumed more grains and greens than the unsuccessful subjects. The groups did differ in the use of rarely eaten foods, low-fat proteins, sweet treats, or fish.

Study 1 Conclusion

The first study shows that the Transtheoretical model is applicable to dietary fat intake, but that there may need to be adjustments or modifications made to take into account the fact that there is a discrepancy between self-perception and behavior. If a person describes themselves as NOT following a low-fat diet, it is almost certain that they will in fact be above the nutrition recommendations for dietary fat. However, if a person describes themselves as following a low-fat diet, there is a very good chance that there will be a discrepancy between this self-description and

their behavior. Enough people describing themselves as on a low-fat diet have made a sufficient amount of change to result in significant group differences in fat intake. However, about 70% of subjects claiming to follow a low fat diet must actually be classified as noncompliant.

Study 2

In study 2, the results of the cluster analysis were used to develop an Eating Styles Questionnaire (ESQ). This questionnaire was administered along the stage of change question and the quick dietary screen to a new sample of African American women. The goal of this study was to confirm the findings of study one and to explore alternative methods for the assessment of where an individual falls in the process of making changes in dietary fat intake.

Methods

Subjects

Subjects were 208 African American women recruited primarily from work sites. Informants were recruited and offered an incentive for helping recruit other women into the study. Each woman was offered \$5.00 to complete the questionnaires and the informants were offered a financial incentive for their assistance. The mean age was 40.4 (S.D. 14.4) and ranged from 14 to 77 years old. The sample was well educated with 23% having a high school education or less, 49% having completed at least some college, and 28% having post graduate education. Fifty-three percent reported incomes of \$20,000 a year or less, 26% earned \$20,000 to \$30,000 a year, 10% earned between \$30,000 and \$40,000, and 11% had incomes of \$50,000 a year or more.

The Eating Styles Questionnaire

The results of the cluster analysis in study 1 were used to create the Eating Styles Questionnaire. Sixteen items were written that represent behaviors associated with reduced fat intakes. The items were based on the clusters that discriminated between groups in study 1. For several clusters, more than one item was generated (e.g., red meat) to reflect different aspects of behavior (e.g., avoiding red meat, trimming the fat). The questionnaire involves rating how often each statement describes one's behavior on a five point scale (1=never to 5 = always).

Stage of change assessment

Stage of change was initially assessed using the following item:

Do you CONSISTENTLY avoid eating high fat foods?

1. **NO and I do NOT intend to in the next 6 months**
2. **NO, but I intend to in the next 6 months**
3. **No, but I intend to in the next 30 days**
4. **YES, and I have been, but for LESS than 6 months**
5. **YES, and I have been for MORE than 6 months**

Second, the following question was asked:

I need to have your Honest opinion about changing your fat intake. The following choices are what it takes to get your fat down to the recommended level.

1. **ALMOST ALWAYS avoid red meats (e.g., ham, bacon, beef, pork, hot dogs).**
2. **ALWAYS use low fat or fat free dairy products (e.g., skim milk, low fat cheese, low fat yogurt).**
3. **ALMOST ALWAYS avoid eating fast foods (e.g., hamburgers, french fries, fried chicken, pizza, and sausage biscuits).**
4. **ALMOST NEVER snack on high fat foods (e.g., donuts, cake, fried pies, chips, peanuts, ice cream, candy bars).**

5. **OFTEN buy the low calorie or low fat version of a product (e.g., lite salad dressing, low fat mayonnaise, reduced fat margarine, reduced fat frozen dinners, fat free crackers, frozen yogurt).**

Are you willing to do all 5 of these things to get your fat down to the recommended levels?

1. **NO, and I do NOT intend to in the next 6 months.**
2. **Yes, and I intend to in the next 6 months.**
3. **Yes, and I intend to in the next 30 days.**

Procedures

Subjects completed the quick dietary screen, the stages of change questions, and the 16-item Eating Styles Questionnaire. Upon completing the questionnaires, they were paid \$5.00 for participating.

Results

Stage of change

Figure 3 presents the distribution of stage of change overall and for women over and under 45 years of age. Unlike the first sample, there was not a significant association between age and stage of change ($X^2 = 7.13$, $df = 4$, $p < 0.13$). There was, however, an association between stage of change and education ($X^2 = 21.09$, $df = 8$, $p < 0.007$). Women with more education tended to be in the action and maintenance stages while those with less education were in the precontemplation and contemplation stages. There was no association between income and stage of change ($X^2 = 18.27$, $df = 12$, $p < 0.11$).

Stage of change and Fat and Fiber Intake

Table 6 summarizes the association between stage of change and fat and fiber intake. Fat intakes were slightly higher than the first sample, and fiber intakes were lower. In a one-way analysis of variances, there was a significant effect for stage ($p < 0.00001$) for both fat and fiber intake. For fat, the maintenance stage was significantly different from the precontemplation, contemplation, and preparation stage. The action stage was significantly lower than the contemplation stage based on Tukey's Honestly Significant Difference Test. For fiber, the maintenance stage was consuming more fiber than subjects in the other four stages.

Compliance was defined as consuming less than 30% of calories from fat and the rates of compliance were compared across the different stages using a chi-square test. There was not a significant difference in rate of compliance by stage ($X^2 = 3.7$, $df = 4$, $p = 0.45$). Overall, only 15 or 7.2% of the subjects were consuming less than 30% of calories from fat. In the action stage, 93% of the subjects were noncompliant and in the maintenance stage, 87.7% of the subjects were noncompliant. A less stringent definition of compliance, 33% of calories from fat or less, was applied and there was a significant difference in compliance by stage ($X^2 = 11.0$, $df = 4$, $p < 0.02$). Using the 33% criteria, 81.5% of subjects in the action stage were noncompliant and 68.5% of the subjects in the maintenance stage were still noncompliant.

The Eating Styles Questionnaire

There are many changes one could make in eating habits in order to reduce dietary fat intake. Consequently, the ESQ was scored by summing the ratings across the sixteen items. Coefficient alpha for this 16-item scale is 0.90. Scores on this scale could range from 16 to 80. The mean total score was 47.0 with a standard deviation of 12.6. The correlation between ESQ total score and percent of calories from fat was -0.65 ($p < .0001$), and the correlation of ESQ total score and grams of fiber was -0.40 ($p < .0001$).

Table 7 presents the individual ESQ items and the ESQ total and compares the means of three groups of subjects: 1) **Not trying** -subjects who were not trying to lower their fat intake (stages 1, 2, and 3), 2) **Noncompliant** - subjects who were trying to lower their fat intake (stages 4 and 5) but who were unsuccessful (greater than 33% of calories from fat), and 3) **Compliant** - subjects who were successful in lowering their fat intake (less than 33% of calories from fat). There were significant group differences on 14 of the 16 items, and on the total score. All three groups differed significantly on total scores and items 1, 2, 3, 4, 5, 6, 9, 11, and 13. The not trying subjects were significantly different from the other two groups which did not differ from each other on items 7, 8, 10, and 16. On items 14, and 15, only the not trying and compliant groups differed significantly.

Restaging

In both studies, the simple question about stage of change clearly separated those who were trying to modify fat intake from those who were not. However, those subjects who indicated they were attempting to lower fat intake were a mixture of compliant and noncompliant subjects, with far more being noncompliant than compliant. It would be useful to be able to form more homogeneous groups of subjects by separating the compliant from noncompliant subjects in the action and maintenance phases. The ESQ results show clearly that the noncompliant subjects are attempting to make changes, but just have not made enough changes in eating behaviors in order to reduce fat intake to target levels. These people are more appropriately placed in the preparation stage, since they are taking steps towards making changes but are not yet fully committed.

The first attempt to adjust the stages involved using the question on changing five sets of behaviors to restage subjects. Subjects were moved from action (n=27) and maintenance (n=19) to preparation if they did not indicate a willingness to change all five behaviors in the next 30 days. Subjects in the precontemplation (n=2) and contemplation (n=0) stages who indicated they planned to change all five behaviors in the next 30 days were moved to preparation, and subjects in the preparation (n=11) stage who did not indicate a willingness to change all five behaviors in the next 30 days were moved to contemplation. Table 8 shows the changes in frequency of the stages and the impact on the percentage of compliant subjects in each stage as a result of this restaging procedure. This approach resulted in an improvement in staging with fewer compliant subjects in the precontemplation and contemplation stages, and more compliant subjects in the action and maintenance phases. However, the majority of subjects in action and maintenance were still noncompliant with 33% of calories from fat using this adjustment.

The second attempt to adjust the stages used the ESQ total score. Subjects in precontemplation and contemplation who scored over 50 on the ESQ were moved to preparation. Subjects in the preparation stage who had ESQ scores greater than 57 were moved to action. Subjects in action and maintenance whose ESQ scores were less than 57 were moved to preparation. Table 8 also displays the results of this adjustment. Far fewer subjects were placed in action and maintenance using this criteria, and consequently the percentage who were compliant was substantially increased. In addition, fewer subjects in the precontemplation and contemplation stages were compliant. Just over half of the subjects were placed in the preparation stage indicating that they were ready to make changes or that they had already made a few changes in their fat intake.

Study 2 Conclusions

In a different sample of educated, middle-aged African American Women, study 2 provided very similar results. Overall, fewer subjects in study two had achieved the goal of 30% of calories from fat. However, the finding that women who described themselves as NOT following a low-fat diet were in fact eating a high fat diet was mostly confirmed. When the criteria of success was relaxed to 33% of calories, a small percentage of women who described themselves as not trying were already below 33% of calories from fat. Similar to study 2, the majority of women who claimed to be on a low-fat diet showed a discrepancy between their self-perception and the eating behavior as assessed by the Quick Dietary Screening Questionnaire. In study two, we obtained data on the newly developed Eating Styles Questionnaire and showed that it was reliable, highly correlated with dietary fat intake, and moderately correlated with dietary fiber intake. An ESQ cutoff of 57 could be used to separate the compliant from the noncompliant subjects. After making this adjustment, it appears that the about half of the women in this sample are best described as being in the contemplation stage. That is they have made some changes in fat intake, and for the most part intend to make additional changes in the near future. However, their level of commitment to a low-fat diet is not yet high enough to achieve a clinically significant reduction in dietary fat intake.

Discussion

There are a number of insights into the application of the Transtheoretical model to dietary fat intake in African American women that can be drawn from this study. The first conclusion is that those woman who describe themselves as in the precontemplation, and contemplation stages are accurately describing their eating behavior. The mean level of fat intake in these subjects was 38-39% of calories from fat which is a level that creates added risk for chronic illness. On the other hand, just because a woman says she is following a low-fat diet does not mean that her dietary fat intake has been reduced to a clinically significant level.

The results of the cluster analysis, and the analysis of the individual ESQ items suggest that these women have made some changes in fat intake when compared to women who are not even trying to change. They accurately perceive that changes have been made in eating habits, but are largely unaware that the changes they have made are not of a sufficient magnitude to reduce their risk for chronic disease significantly.

When stage of change is based both on self-perception and an measure of degree of commitment to dietary fat reduction as measured by the ESQ, it is possible to better separate these woman into clinically meaningful groups. However, since only 7% of the sample in study two had actually achieved the healthy persons 2000 goals, even those remaining in the action and maintenance stages after adjustment would benefit from making further changes in dietary behaviors.

An obvious question raised by this study is whether or not these findings are unique to middle class, educated, African American women, or whether other populations would also show a similar discrepancy between self-perception of eating a low-fat diet and actual success in meeting clinically meaningful goals. It is clear that clinical efforts to induce dietary change in this population need to include both assessment of self-perception of stage of change, and an independent assessment of the full range of dietary changes required to achieve a reduced fat intake. Additional research in other populations will be needed to determine how common it is for those who believe they are following a low-fat diet to actually be noncompliant with clinically meaningful goals.

There are a number of important limitations to this study. As in all research on dietary intake, the method of assessing fat intake is admittedly less than perfect. It may be that some of the errors in classification of subjects as compliant and noncompliant are as much due to the imperfections in the Quick Dietary Screening Questionnaire as they are due to lack of meaningful behavior change. We believe, however, that the Quick Dietary Screening Questionnaire is sufficiently accurate to establish that a substantial number of persons describing themselves as in the action or maintenance stage should be more realistically considered to belong in the preparation stage.

The recruitment methods used in both studies did not result in a representative sample of African American women. There are a number of potentially subtle biases that may have been introduced by analyzing the data from a small proportion of the population that responded to the request to complete questionnaires in study 1, and by paying subjects \$5.00 to participate in study 2. It appears that the methods in study 1 yielded a greater number of subjects who were successfully eating a low-fat diet than the method in study two. It is difficult to assess all possible biases these recruitment methods might have introduced.

The results of both studies suggest that age and/or education are associated with eating behaviors in African American women. However, both studies had an underrepresentation of young women, poor women, and poorly educated women. A more diverse sample might have resulted in larger age and education effects. Finally, the lack of a European American comparison group raises many questions about the extent to which these findings are specific to African American women, or are part of a more general tendency towards a discrepancy between self-perception of eating a low-fat diet and the actual dietary behaviors.

The results of the cluster analysis and the development of the ESQ provide direction for the development of clinical and primary prevention programs for this population. The effort to reduce fat intake needs to focus not only on obvious behaviors like eating less red meat and snack foods, but also needs to attend to the use of dressing and spreads, food preparation methods, the fat in foods like poultry and lunch meats, the reduction in high fat dairy foods, and the need to increase intake of fruits, vegetables, and the use of specially formulated low-fat food products. It may be possible to use the ESQ as an individual assessment tool that can give people feedback on those behaviors they have changed, and those behaviors they need to attend to in order to achieve clinically meaningful change.

References

1. Holtz, S.N., Allston, J.A., Birkett, N.J., Baskerville, B., & Dunkley, G. (1995). Fat-related dietary behavior: Behavioral science concepts for public health practice. *Canadian Journal of Public Health*, 82, 114-119.
2. Ernst, N. (1993). Nutrition and health policy regarding fat consumption for U.S. population. *Acta Cardiologica*, 48, 479-481.
3. U.S. Department of Health and Human Services (1988). *Healthy people 2000: National health promotion and disease prevention objectives*. Washington: Public Health Service.
4. Browner, W.S., Westenhouse, J. & Tice, J.A. (1991). What if Americans ate less fat? A quantitative estimate of the effect on mortality. *Journal of the American Medical Association*, 265, 3285-3291.
5. Greenwald, P. Sondik, E.J. (1986). Cancer control objectives for the Nation: 1985-2000. NCI Monograph, 2, 1-105.

6. Hargreaves, M.K., Baquet, C.R., & Gamshadzi, A. (1989). Diet, nutritional status, and cancer risk in American Blacks. Nutrition and Cancer, 12, 1-28.
7. Heckler, M. (1985). Report of the Secretary's Task Force on Black and Minority Health Vol I: Executive Summary. USDHHS.
8. McDowell, M.A., Briefel, R.R., Alaimo, K., Bischof, A.M., Caughman, C.R., Carroll, M.D., Loria, C.M., Johnson, C.L. (1994). Energy and macronutrient intakes of persons ages 2 months and over in the United States: Third national health and nutrition examination survey, Phase 1, 1988-91. Vital and Health Statistics of the Centers for Disease Control and Prevention, 255, 1-23.
9. National Research Council, (1989). Diet and Health: Implications for reducing chronic disease risk. National Academy of Sciences Press, Washington, DC.
10. Terris, M. (1992). Healthy lifestyles: The perspective of epidemiology. Journal of Public Health Policy, 186-194.
11. Glanz, IC, & Mullis, RM. (1988). Environmental Interventions to promote healthy eating: A review of models, programs and evidence. Health Education Quarterly 15, 395-415.
12. Olson, CM, Kelly GL (1987). The challenge of implementing theory-based intervention research in nutrition education. Journal of Nutrition Education, 21, 280-284.
13. Leventhal, H. & Cameron, L. (1987). Behavioral theories and the problem of compliance. Patient Education and Counseling, 10, 117-138.
14. Meichenbaum, D., & Turk, D. C. (1987). Facilitating treatment adherence. New York: Plenum Press.
15. Prochaska, JO & DiClemente, CC. (1983). Stages and processes of self-change of smoking: Toward an integrative model of change. Journal of Consulting and Clinical Psychology, 56, 390-395.
16. Prochaska, JO & DiClemente, CC. (1985) Common processes of self-change for smoking, weight control, and psychological distress. In S. Shiffman & T. Willis (Eds.). Coping and Substance Abuse (pp. 345-365). New York: Academic Press. 1985.
17. Prochaska, JO & DiClemente, CC. (1986). Towards a comprehensive model of change. In W. Miller & N. Heather (Eds.), Treating Addictive Behaviors (p. 3-27). New York: Plenum Press.
18. DiClemente, CC, & Prochaska, JO. (1982). Self-change and therapy change of smoking behavior: A comparison of processes of change of cessation and maintenance. Addictive Behaviors, 7, 133-142.
19. Velicer, W.F. DiClemente, CC, & Rossi, JS, et al. (1990). Relapse situations and self-efficacy: An integrative model. Addictive Behaviors, 15, 271-283.
20. DiClemente, C, Prochaska, J, and Gibertini, M. (1985). Self-efficacy and the stages of self-change of smoking. Cognitive Therapy and Research, 9, 181-200.
21. Prochaska, J.O., Velicer, W.F., Rossi, J.S., & Goldstein, M.G. (1994). Stages of change and decisional balance for 12 problem behaviors. Health Psychology, 13, 39-46.
22. Bowen, D.J., Meischke, H., Tomoyasu, N. (1994). Preliminary evaluation of the process of changing to a low-fat diet. Health Education Research, 9, 85-94.
23. Kristal, A.R., Shattuck, A.L., Henry, A.J., & Fowler, A.S. (1990). Rapid assessment of dietary intake of fat, fiber, and saturated fat. Validity of an instrument suitable for community intervention research and nutrition surveillance. American Journal of Health Promotion, 4, 288-295.

Table 1: Fat and fiber intake by age, education, and income in 174 African American women

<i>Variable</i>	<i>%fat</i>	<i>S.D.</i>	<i>P</i>		<i>Fiber</i>	<i>S.D.</i>	<i>P</i>
Overall	37.1	7.0			15.4	6.7	
Age			.0001				0.11
Under 45	39.2	6.6			14.7	6.7	
Over 45	34.0	6.3			16.4	6.7	
Education			0.14				0.10
High School	37.5	7.2			15.3	4.3	
College	38.0	7.6			16.5	7.9	
Graduate	35.8	5.7			14.1	5.8	
Income			0.17				0.40
< 20,000	38.0	6.7			16.5	7.6	
20,000-30,000	37.6	7.1			14.8	6.6	
30,000-40,000	35.4	7.0			14.1	4.8	
>40,000	33.2	7.8			16.2	6.0	

Table 2: Fat and Fiber Intake by Stage of Change in 174 African American Women

<i>Stage of Change</i>	<i>% fat</i>	<i>S.D.</i>	<i>P</i>		<i>Fiber</i>	<i>S.D.</i>	<i>P</i>
Precontemplation	42.0	5.0	0.001		15.2	7.1	0.54
Contemplation	42.3	5.9			17.4	8.6	
Preparation	38.6	5.6			15.7	5.8	
Action	36.2	6.2			14.7	7.5	
Maintenance	33.1	6.2			14.9	5.2	

Table 3: Stage of Change and Success in Reducing Dietary Fat Intake in 174 African American Women.

Stage of Change	Low Fat Diet	High Fat Diet
Precontemplation	0	23
Contemplation	0	27
Preparation	0	21
Action	8	34
Maintenance	22	39

Cells indicate the number of subjects in each stage consuming a low fat diet (less than 30% of calories from fat, or a high fat diet (more than 30% of calories from fat).

Table 4: Comparison of Subject Groups on Food Clusters

Food Group	Not trying		Unsuccessful		Successful		P<
	Mean	S.D.	Mean	S.D.	Mean	S.D.	
Rarely Eaten	.24	.24	.18	.17	.19	.19	.25
Eating Out	.79	.31	.64	.36	.28	.33	.00001
Snack foods	.75	.26	.60	.31	.30	.27	.00001
Chicken	.73	.45	.71	.46	.43	.50	.008
Meats	.62	.29	.42	.31	.09	.13	.00001
Daily Fats	.51	.32	.40	.33	.16	.33	.00001
Vegetables	.76	.30	.84	.21	.96	.13	.006
Low fat products	.33	.40	.36	.42	.62	.39	.005
Breakfast foods	.40	.40	.31	.32	.68	.36	.00001
Low-fat proteins	.54	.39	.45	.38	.56	.44	.20
Sweet treats	.49	.41	.43	.42	.43	.37	.62
Fish	.48	.42	.47	.40	.45	.38	.91
Fruits	.48	.39	.49	.35	.69	.31	.02
Grains and greens	.61	.32	.57	.30	.75	.25	.03

Table 5: Fat and fiber intake by age, education, and income in 208 African American Women.

<i>Variable</i>	<i>%fat</i>	<i>S.D</i>	<i>P</i>		<i>Fiber</i>	<i>S.D.</i>	<i>P</i>
Overall	38.7	6.1			11.5	3.5	
Age			.0008				0.0007
Under 45	39.8	5.8			10.9	3.5	
Over 45	36.9	6.2			12.6	3.3	
Education			0.0001				0.41
High School	40.7	5.8			11.1	4.2	
College	39.3	5.8			11.5	3.2	
Graduate	35.8	5.8			12.0	3.6	
Income			0.02				0.48
< 20,000	39.6	6.1			11.2	3.6	
20,000-30,000	39.2	5.7			11.5	3.8	
30,000-40,000	35.8	4.0			11.1	2.8	
>40,000	36.5	7.9			12.5	3.6	

Table 6: Fat and Fiber Intake by Stage of Change in 208 African American Women

<i>Stage of Change</i>	<i>n</i>	<i>% fat</i>	<i>S.D.</i>	<i>P</i>		<i>Fiber</i>	<i>S.D.</i>	<i>P</i>
Precontemplation	28	41.0	6.9	0.00001		10.3	4.1	0.00001
Contemplation	33	42.8	5.9			11.3	3.8	
Preparation	34	40.1	5.6			9.7	2.9	
Action	56	37.9	5.4			11.5	5.3	
Maintenance	57	35.2	4.5			13.4	7.0	

Table 7: Comparison of Subject groups on the Eating Styles Questionnaire

Eating Styles Questionnaire Item	Not trying ^a	Noncompliant ^b	Compliant ^c	P <
1. I avoid eating hamburgers, fried chicken, french fries, and other high-fat foods at fast food restaurants.	2.2 (1.0) ^d	3.3 (0.9)	3.7 (0.9)	.00001
2. When I eat at a restaurant, I look for low-fat foods to order.	2.3 (1.1)	3.0 (1.0)	3.8 (0.9)	.00001
3. I choose snack foods that are low in fat or fat free.	2.5 (1.0)	3.3 (0.8)	3.8 (0.8)	.00001
4. When I want to eat meat, I choose baked, broiled, or boiled chicken without the skin instead of red meat.	2.6 (1.1)	3.2 (1.0)	4.1 (0.8)	.00001
5. I avoid eating red meat (beef, ham, liver, or pork).	2.4 (1.2)	3.1 (1.0)	3.8 (0.8)	.00001
6. When I eat red meat (beef, hamburgers, ham, hot dogs, or pork) I choose very lean cuts or trim off the fat (answer always if you never eat red meat)	3.0 (1.2)	3.6 (1.2)	4.2 (0.8)	.00001
7. When I eat lunch meats (bologna, sliced ham, sliced turkey, salami) I often choose cuts that are low in fat or fat free (answer always if you never eat lunch meats).	2.8 (1.3)	3.7 (1.2)	4.1 (1.0)	.00001
8. I avoid using butter, margarine, gravy, regular mayonnaise, and salad dressings made with oil.	2.4 (1.2)	3.2 (1.2)	3.6 (1.1)	.00001
9. I eat five or more servings of fruits and vegetables every day.	2.1 (1.0)	2.7 (1.1)	3.1 (1.0)	.00001
10. When I have a choice between a regular product and one that is low-fat or fat free, I choose the low-fat or fat free product.	2.5 (1.0)	3.6 (1.0)	3.6 (1.0)	.00001
11. When I buy dairy products (milk, yogurt, cheese, ice-cream), I buy items that are low-fat or fat free.	2.6 (1.4)	3.4 (1.1)	4.0 (1.1)	.00001
12. I eat a serving of bread, rolls, bagels, rice, pasta, grits, oatmeal, or cereal at every meal.	3.1 (1.3)	3.1 (1.1)	3.2 (1.2)	.97
13. I eat a green salad every day.	2.1 (1.0)	2.6 (1.0)	3.2 (1.1)	.00001
14. When I eat greens and other vegetables, I never use fatback, butter, or other fats for seasoning.	2.8 (1.3)	3.1 (1.2)	3.3 (1.6)	.27
15. When I eat grits, I avoid adding butter or margarine.	2.1 (1.5)	2.3 (1.4)	2.9 (1.3)	.04
16. I avoid eating nut-breads, biscuits, or crossaint and choose breads that are low in fat or fat free instead.	2.2 (1.1)	2.9 (1.0)	3.3 (1.1)	.00001
ESQ Total score	40.0 (11.3)	50.0 (9.6)	57.6 (8.0)	.00001

a Subjects in the precontemplation, contemplation, and preparation stages

b Subjects in the action and maintenance stages consuming more than 33% of calories from fat

c Subjects in the action and maintenance stages consuming less than or equal to 33% of calories from fat

d The mean rating on a 1-5 scale with the standard deviation in parenthesis.

Table 8 Effects of different restaging strategies in 200 African American Women

Stage	1 st Question ^a	% Compliant ^b	2 nd Question ^c	% Compliant ^b	ESQ-57 ^d	% Compliant ^b
Precontemplation	28	17.9%	26	15.4%	23	8.7%
Contemplation	32	6.3%	43	4.7%	30	3.3%
Preparation	32	9.4	68	14.7%	111	10.8%
Action	54	18.5%	28	28.6%	12	75.0%
Maintenance	54	31.5%	35	37.1%	24	54.2%

- a The number of subjects classified into each stage based on the single multiple choice question.
- b The percentage of subjects at each stage consuming less than or equal to 33% of calories from fat.
- c The number of subjects at each stage when adjusted using the second question.
- d The number of subjects at each stage adjusted using a score of 57 on the ESQ.

Figure 1: Stage of Change by Age in 174 African-American Women (Study 1)

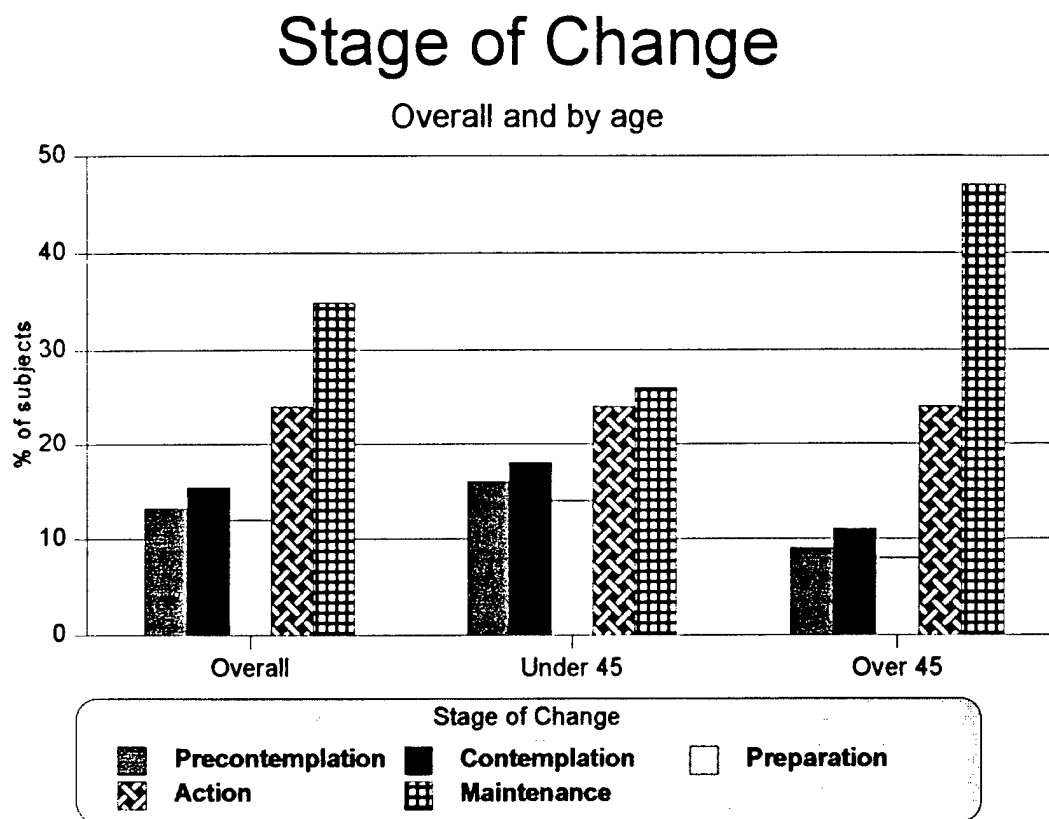

Figure 2: Results of Hierarchical Cluster Analysis of Quick Dietary Screening Questionnaire

Cluster Food Mean Rescaled Squared Euclidian Distance

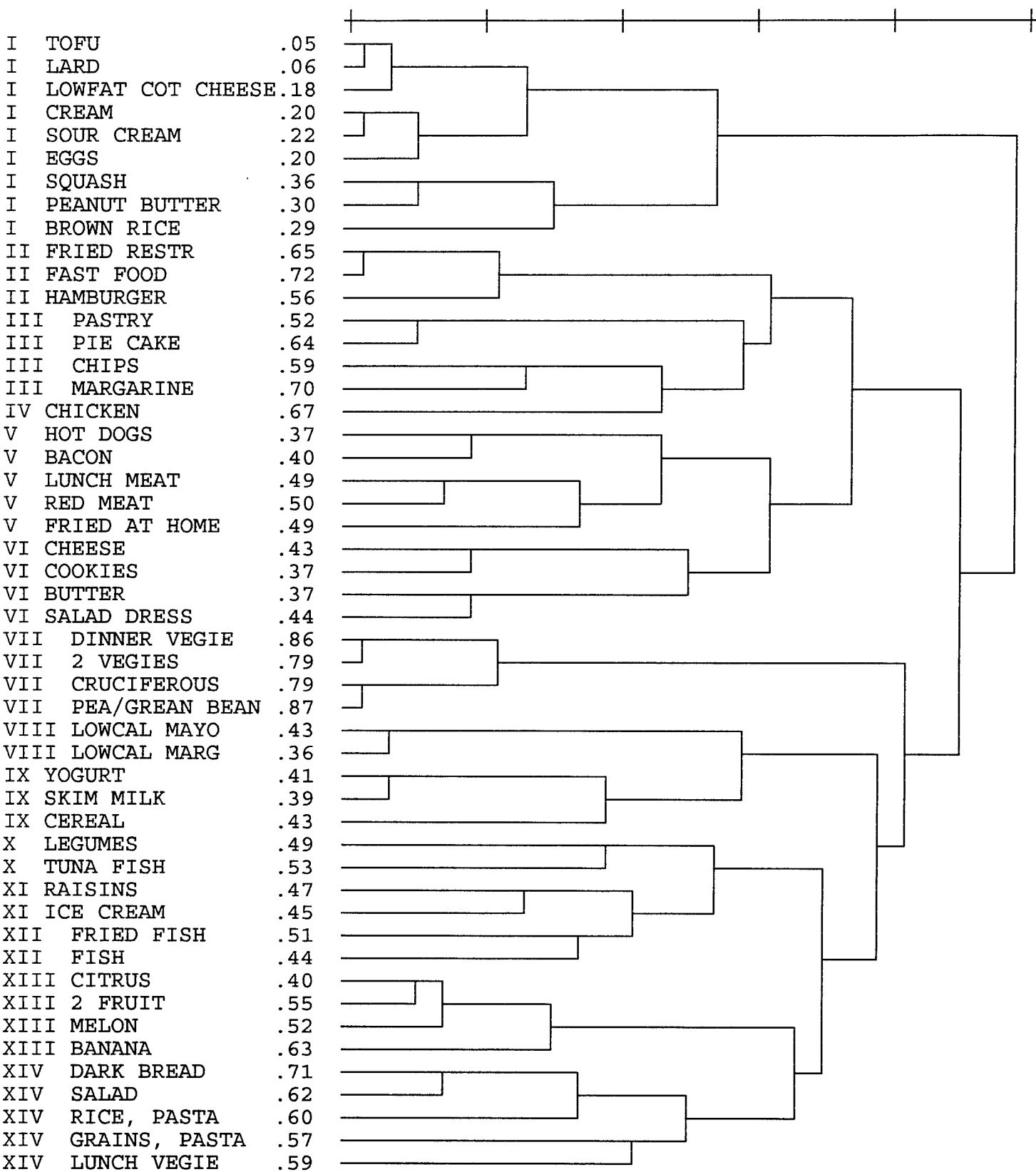
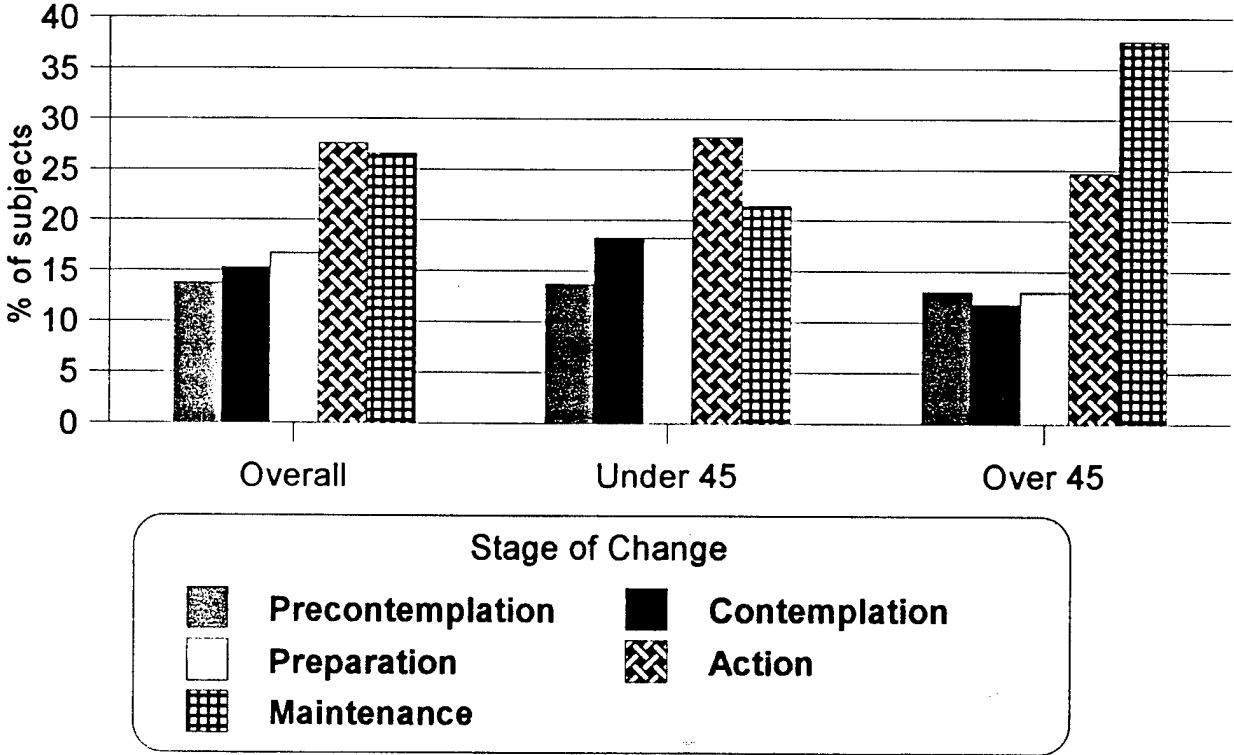

Figure 3: Stage of change by Age in 208 African American Women

Stage of Change

Overall and by age



APPENDIX

Eating Styles Questionnaire

The following questions have to do with eating habits. For each question, decide whether the statement describes your eating habits. Please Answer each question as honestly as possible. Answer by circling the choice that best describes how often each statement applies to you and your eating habits.

1. I avoid eating hamburgers, fried chicken, french fries, and other high-fat foods at fast food restaurants.

Always	Usually	Sometimes	Rarely	Never
1	2	3	4	5

2. When I eat at a restaurant, I look for low-fat foods to order.

Always	Usually	Sometimes	Rarely	Never
1	2	3	4	5

3. I choose snack foods that are low in fat or fat free.

Always	Usually	Sometimes	Rarely	Never
1	2	3	4	5

4. When I want to eat meat, I choose baked, broiled, or boiled chicken without the skin instead of red meat.

Always	Usually	Sometimes	Rarely	Never
1	2	3	4	5

5. I avoid eating red meat (beef, ham, liver, or pork).

Always	Usually	Sometimes	Rarely	Never
1	2	3	4	5

6. When I eat red meat (beef, hamburgers, ham, hot dogs, or pork) I choose very lean cuts or trim off the fat (answer always if you never eat red meat).

Always	Usually	Sometimes	Rarely	Never
1	2	3	4	5

7. When I eat lunch meats (balogna, sliced ham, sliced turkey, salami) I often choose cuts that are low in fat or fat free (answer always if you never eat lunch meats).

Always	Usually	Sometimes	Rarely	Never
1	2	3	4	5

8. I avoid using butter, margarine, gravy, regular mayonaise, and salad dressings made with oil.

Always	Usually	Sometimes	Rarely	Never
1	2	3	4	5

9. I eat five or more servings of fruits and vegetables every day.

Always	Usually	Sometimes	Rarely	Never
1	2	3	4	5

10. When I have a choice between a regular product and one that is low-fat or fat free, I choose the low-fat or fat free product.

Always	Usually	Sometimes	Rarely	Never
1	2	3	4	5

11. When I buy dairy products (milk, yogurt, cheese, ice-cream), I buy items that are low-fat or fat free.

Always	Usually	Sometimes	Rarely	Never
1	2	3	4	5

12. I eat a serving of bread, rolls, bagels, rice, pasta, grits, oatmeal, or cereal at every meal.

Always	Usually	Sometimes	Rarely	Never
1	2	3	4	5

13. I eat a green salad every day.

Always	Usually	Sometimes	Rarely	Never
1	2	3	4	5

14. When I eat greens and other vegetables, I never use fatback, butter, or other fats for seasoning.

Always	Usually	Sometimes	Rarely	Never
1	2	3	4	5

15. When I eat grits, I avoid adding butter or margarine.

Always	Usually	Sometimes	Rarely	Never
1	2	3	4	5

16. I avoid eating nut-breads, biscuits, or crossaint and choose breads that are low in fat or fat free instead.

Always	Usually	Sometimes	Rarely	Never
1	2	3	4	5

**C. DEVELOPMENT AND EVALUATION
OF AN EATING BEHAVIOR
PATTERNS QUESTIONNAIRE**

Purpose

Diet and Breast Cancer Risk. Fat and fiber intake have been implicated as possible etiological factors in breast, colon, prostate, and other hormone related cancers (1,2). International epidemiological studies have shown a correlation between usual fat intake and the prevalence of breast cancer (3). However, it has been difficult to establish a causal link between diet and breast cancer (4). This may be partly due to methodological difficulties in quantifying dietary fat intake and eating behaviors for epidemiologic research.

Dietary Assessment Methodologies. Three major methodologies for quantifying fat intake have been used in epidemiological research: 1) dietary records and recalls, 2) food frequency questionnaires, and 3) eating behavior pattern questionnaires (5-6). Each method has strengths and weaknesses.

Food diaries capture an actual sample of food intake, but have a high response cost for subjects, are expensive to analyze, and typically underestimate total energy intake (5,7). Twenty-four hour diet recalls, conducted at random times, are less of a response burden for subjects and introduce less bias due to reactivity of the measurement procedure, but multiple recalls are required for accuracy and they are expensive to administer and analyze (8).

Food frequency questionnaires are recognized as a reasonable way to quantify usual nutrient intake in groups of subjects (9-11). They are easier to administer and less expensive than diaries and recalls, but introduce different sources of bias and cannot be used to measure intraindividual variability (12-16).

Eating behavior pattern questionnaires have been less often used (16). These questionnaires measure behaviors associated with the intake of specific food components. For example, the Kristal Eating Patterns Questionnaire, used in the women's health trial, was developed to measure behaviors associated with restriction of fat intake and attempts to increase fiber intake. (17-18). Eating pattern questionnaires are a less efficient way to estimate usual nutrient intake, but have the advantage of being able to identify the specific behaviors (e.g., trimming the fat from meat, removing chicken skins) that contribute to usual nutrient intakes.

The Need for an Eating Behavior Patterns Assessment. An eating behavior pattern questionnaire would be useful in both clinical and community interventions (15). Clinically, it would be helpful to identify for individuals those behaviors that could be targeted for change in order to reduce fat and increase fiber intake. In community interventions, it would be very useful to understand the behaviors within the population that result in high fat, low fiber diets. The cultural and environmental factors that promote and reinforce these behaviors could be targeted in community level interventions (17). An eating behavior patterns questionnaire would also be useful in evaluating clinical and community intervention programs (15). For epidemiological research, it may be very useful to break fat intake and fiber intake into behavioral components so that we can learn which behaviors in a particular population are creating excess disease risk.

Dietary Assessment for Minority Populations. Cronin (15) has argued that dietary assessment methods may need to be tailored specifically to the population being studied. She suggests that methodologies may need to be evaluated before use in an ethnic or minority population. The unknown reliability and validity of these measures when used with special ethnic and minority populations is another problem that inhibits good epidemiological research on diet and breast cancer. There have been several attempts to modify food frequency questionnaires for use in minority populations (19-20). At Meharry Medical College, the Block food frequency

questionnaire has been modified for use with African American men living in the Nashville area (20). The modifications involved adding foods that are characteristically eaten by African Americans in the Southern United States (e.g., grits, okra, and greens). The Kristal Eating Patterns Questionnaire has been modified slightly for use in minority populations, but these changes were not dictated by data on the eating behavior patterns of minorities (5).

Specific Aims

1. To identify patterns of eating behavior, dietary habits, and cultural beliefs about food intake in Southern urban African American women.
2. To develop and refine a culturally specific eating behavior patterns (EBP) questionnaire that predicts the intake of food components associated with breast cancer risk such as total fat, fiber, and micronutrient intakes.
3. To calibrate the modified EBP questionnaire using a food frequency questionnaire that has been modified for use with African Americans, an existing EBP questionnaire, and 3-day food records.

Methods

Design Overview

This project was divided into three phases. Phase I involved the development of an Modified Eating Behavior Pattern Questionnaire (MEBP) that is culturally sensitive for use with African American women using an empirical strategy. Phase II involved pilot testing and refinement of the questionnaire. Phase III is a calibration study in which the MEBP is correlated with the results of the Meharry Food Frequency Questionnaire, the Kristal Eating Patterns Questionnaire, and a three-day food diary. This phase will demonstrate which patterns of behavior are most strongly associated with fat, fiber, and selected micronutrient intakes.

Phase 1

Subjects. Forty African American women were recruited from a pool of individuals who had participated in previous research studies on nutrition and behavior in African American women. Potential subjects were contacted by phone and asked to participate in a focus group.

Focus group protocol. A focus group protocol was developed to elicit discussion of a wide range of attitudes, beliefs, and behaviors related to daily eating habits. The protocol included sections on: 1) Meal patterns, 2) food purchasing, 3) eating out, 4) the role of food in family and community, 5) food and health beliefs, 6) food and emotions, and 7) food preparation. Specific questions were developed for each topic in order to initiate and facilitate group discussion. Table 1 presents an outline of the focus group protocol. For each of the questions in Table 1, there was a list of additional questions and prompts available to the focus group leader to use if needed in order to facilitate further discussion of the subject area.

Meharry Food Frequency Questionnaire. The Meharry Food frequency questionnaire is a modification of standard food frequency measures that includes ethnic items applicable to the Nashville African American community as well as a wide range of low-fat and fat-free food products. The food list was designed to be able to provide an accurate assessment of food intake for a wide range of individuals from those eating a traditional "soul-food" diet to persons who are very health conscious. The inventory consists of 130 specific foods divided into nine sections: Meats, dairy, fruits, vegetables, breads and grains, snacks and desserts, condiments, beverages, and fast foods/convenience foods. The USDA nutrient data base was used to quantify the composition of each food, and the portion sizes were based on those used in similar food frequency measures.

Dietary Recall. A simple form was developed with instructions for recording all food eaten during the previous 24-hours. The form was divided into breakfast, lunch, supper, and snacks in order to prompt people's memories. The purpose of the dietary recall was to have an independent way to obtain a listing of commonly eaten foods in the study population. Subjects were instructed to record portion sizes, but no procedures were used to insure accurate portion estimates.

Procedures. Five focus groups consisting of eight women in each group were scheduled and conducted. The groups were conducted at the lunch hour, and a free lunch was provided to all participants. In addition, participants were paid \$5.00 for participating in the focus group. Upon arriving, the participants were given the food frequency questionnaire and the dietary recall form to complete. After all were present and lunches were distributed, the group leader began asking questions from the focus group protocol. The discussions were tape recorded, and the participant's answers to the focus group questions were transcribed.

Item generation. Two of the authors (DS, JB) took copies of the transcripts, the food frequency questionnaires, and the dietary recalls and used these to write questionnaire items. The goal was to write items that describe eating attitudes and behaviors.

Results

JS wrote 139 questionnaire items and DS wrote 136 items. The two sets of items were combined, and then sorted into ten categories: 1) specific meals, 2) planning, 3) family/social, 4) snacking, 5) food preferences, 6) health awareness, 7) shopping/purchasing foods, 8) food preparation, 9) eating out, and 10) emotional. The complete pool of sorted items is presented in Appendix A. The items were reviewed within each category, and redundant items or vague and poorly worded items were eliminated. Within each category, some highly similar items were also eliminated and 113 items were retained for the first version of the Eating Behavior Patterns Questionnaire. This version of the questionnaire is presented in Appendix B. Items were then rewritten to make each item as clear and succinct as possible, and to also utilize simple language and vocabulary. The questionnaire instructions were:

Read each item and think if you agree or disagree that the item describes you and your eating habits. Place an "x" in the box that best describes your level of agreement with each statement. If a statement does not apply to you (for example a question asks about what you do at work and you do not have a job), then mark the neutral N/A (not applicable) box.

Each item is rated on a five point scale: 1= strongly disagree, 2 disagree, 3 = neutral or not applicable, 4 = agree, 5 = strongly agree.

A focus group of 10 African American women were recruited to review the questionnaire. The group went through the questionnaire one item at a time and discussed how items might be worded more clearly, or how wording or terminology might better reflect an African American vocabulary.

Phase II:

Design overview

The purpose of phase II was to empirically reduce the number of items in the questionnaire, to examine its potential factor structure, and to take a preliminary look at its ability to predict nutrient intakes. The Preliminary Eating Behavior Patterns Questionnaire was Administered to a sample of subjects along with the Meharry food Frequency Questionnaire.

Subjects and procedures.

Subjects were 80 African American women recruited from Meharry Medical College, Fisk University, Vanderbilt University, and Tennessee State university faculty, staff, and employees. None of these women had participated in the earlier focus groups. Each woman completed the Meharry Food Frequency Questionnaire and the Preliminary Eating Behavior Patterns Questionnaire. Potential subjects were contacted by telephone and asked to participate, contacted in person, or recruited to participate at a work site health fair. In some cases, subjects met in small groups with an investigator who then administered the questionnaire. In other instances, the questionnaires were exchanged using campus mail or by fax. At the health fair, participants were given feedback on the Meharry Food frequency questionnaire as an incentive for completing the measures.

Results

The mean, standard deviation, and frequency distribution for each item was calculated and used to eliminate items with low variability or skewed distributions. The correlation between each item and percent of calories from fat and grams of fiber was calculated. Fat and fiber intake were estimated by scoring the Meharry Food Frequency Questionnaire. Items with no correlation with fat or fiber intake were also eliminated. These steps reduced the item pool from 113 to 95 items.

A factor analysis was conducted using principal components and varimax rotation. Examination of the Eigenvalues led to choosing a six factor solution. The six factors were named: low fat eating, snacking and convenience, emotional eating, planning ahead, meal skipping, and cultural/lifestyle behaviors. The items with factor loadings of 0.35 or greater were listed under each factor. When an item loaded higher than 0.35 on more than one factor, it was placed with the factor for which it had the highest item loading.

The list of items was examined, and used to select 6-11 items from each factor for the final version of the questionnaire. This selection process involved eliminating items which were too similar to other items and attempting to cover as many different behaviors that serve as examples of each factor as possible. The final version of the Eating Behavior Patterns Questionnaire consists of 52 items and is presented in Appendix C. A score for each factor was created by summing the ratings of the items contributing to that factor. The six factors, their reliability assessed using coefficient alpha, the scale means, and scale standard deviations along with the 52 selected items are presented in table 2.

Relationship of the Eating Behavior Patterns Questionnaire to nutrient intake.

The correlation between the six factor analytically derived scales of the Eating Behavior Patterns Questionnaire and kcal, total fat, saturated fat, and percent of calories from fat. The correlations are presented in Table 3. Three of the scales — low fat, snacking, and cultural patterns — were significantly correlated with these measures of energy and fat intake.

Multiple regression was used to determine the relationship between the six eating behavior pattern factors and selected macronutrient and micronutrient intakes. Age and body mass index (BMI) were also included as predictors in this analysis. Intakes were estimated from the Meharry Food Frequency Questionnaire. The regression models were formed using step wise regression, and the best regression model is summarized in Table 4. All of the selected nutrients except vitamin C could be significantly predicted from the Eating Behavior Patterns Questionnaire. The best equation was for percent of calories from fat.

Discussion of Phase II

In phase II, we were able to successfully reduce the size of the questionnaire from 113 items to 52 items. A factor analysis resulted in six interpretable factors. When treated as subscales,

the scores show adequate to good reliability. The goal of the development of this questionnaire was to create a tool for estimating fat intake from behavior. The correlation and regression analysis suggest that the revised eating behavior patterns questionnaire has potential for being a tool to use in studying dietary fat intake in African American women.

The phase II data have some definite limitations. The sample was gathered from students, employees, and participants in a health fair. The group we sampled averaged only 29% of calories from fat suggesting that we obtained a very health conscious sample. The questionnaire may perform differently when a more diverse sample is obtained. The factor analysis was conducted with only a small number of subjects. The six factor structure of this questionnaire needs to be confirmed in a larger sample.

Despite the limitations of this sample, it is interesting that the best predictor of calorie and fat intake was the score on the cultural subscale. This subscale reflects, in part, the extent to which a woman uses traditional "soul foods" and soul food preparation techniques. We consider this a potentially strong feature of this questionnaire since it will make it useful for studying fat intake in at least Southern American black populations.

Phase III

Design Overview

To determine how well our modified eating behavior pattern questionnaire assesses behaviors associated with dietary cancer risk, the questionnaire scores will be compared to 3-day food diaries, the original Kristal Eating Behavior Patterns questionnaire, and the Meharry Food Frequency questionnaire. First, we will conduct a factor analysis to form subscales of the MEBP questionnaire that represent different styles or clusters of behaviors. Multiple regression techniques will be used to determine how well the MEBP questionnaire subscales predict intake of fat, fiber, and micronutrients. These regression models will also allow us to estimate individual's usual percent of energy from fat, fiber intake, and intake of key micronutrients from the MEBP responses.

Subjects

Subjects were recruited from a variety of sources in the Nashville and Middle Tennessee. Sources included worksites, professional organizations, community centers, and churches. Subjects were offered a \$30.00 payment for completing the questionnaires and diaries. A total of 157 subjects were recruited and completed the data collection.

Measures

The revised 52-item eating behavior pattern questionnaire was administered. A copy is presented in Appendix C. In addition, we administered the Kristal Eating Behavior Patterns Questionnaire, and the Meharry Food Frequency Questionnaire (see Appendix D).

Subjects were given instruction in keeping a food diary. They were told to write down all the foods and beverages consumed during two week days and one weekend day. They were given written instructions, and the instructions were reviewed verbally. A written guide to estimating portion sizes that included drawings that could be used to estimate the portions of solid and liquid foods was given to each participant (21). When participants returned the diaries, a registered dietitian reviewed each diary with the subject and asked follow up questions about any foods that were inadequately documented or for which there was not sufficient portion size information.

Progress to date

All of the data for phase III has been collected. The Nutritionist IV computer nutrient analysis program is being used to analyze the three day diaries. Our data will be selected nutrient intakes averaged over the three days. Currently, we have completed the analysis of diaries from 20 subjects. The mean kcal and fat intakes for these first 20 subject suggest an average calorie intake of 1600 per day with approximately 35% of the calories from fat. These values are expected to change as more data becomes available.

The questionnaires await data entry and processing. It is anticipated that these tasks will be completed within the next month and that analysis of the phase III data will begin shortly after that.

Discussion

The goal of this project was to develop a culturally sensitive measure of fat and fiber intake for use with African American women in the study of breast cancer and other chronic diseases. The item pool for this measure was carefully developed using focus groups, and an initial pool of 113 items was selected for further study. Data from a sample of 80 African American women was used to reduce the size of the questionnaire to 52 items, and to identify six factor analytically derived scales. These scale measure different aspects of eating behavior such as snacking, emotional eating, and cultural food practices. Our preliminary analysis suggests that our goal of creating a behavioral assessment that is predictive of fat intake is likely to be achieved. While the instrument is correlated with the consumption of fiber and selected micronutrients, these correlations were not very strong.

Our original goal for phase III was to obtain 90 completed sets of questionnaires and food records. We have exceeded this goal and have a total of 157 sets of data. We anticipate that this data set will allow us to investigate the reliability and validity of the Eating Behavior Patterns Questionnaire with considerable accuracy.

This project will result in the development of a new measurement instrument that can be used in epidemiological and intervention research on nutrition and breast cancer. Specifically, it would fill a much needed gap in the methodology for studying dietary intake and breast cancer risk. In addition, it will be a valuable tool for use in clinical and community projects designed to intervene with African American women. While this is an independent project, the development of an eating behavior patterns questionnaire will be immediately useful in the parent project. We can use this tool to further evaluate newly development measures derived from the Transtheoretical Model. It will also be useful as a intervention planning tool in the pilot project and demonstration trial. A validated questionnaire for measuring eating behavior patterns related to cancer risk in African American women will also be useful to other ongoing and future epidemiological and intervention studies.

The proposed project will be a demonstration of how to develop population specific behavioral measures. This method can then be used in other populations with culturally unique food habits such as black men, Hispanics, native Americans, and different age groups. This project involves the beginning of new collaborative effort between several higher education institutions in Tennessee. This investigator group intends to pursue other future collaborative projects in the area of nutrition and breast cancer.

References

1. U.S. Department of Health and Human Services (1988). Healthy people 2000: National health promotion and disease prevention objectives. Washington: Public Health Service.
2. Hulka, B.S. (1989). Dietary fat and breast cancer. Preventive Medicine, 18, 180-193.
3. Greenwald, P. (1989). Strengths and limitations of methodological approaches to the study of diet and cancer. Preventive Medicine, 18:163-166.
4. Mansfield, C.M. (1993). A review of the etiology of breast cancer. Journal of the American Medical Association, 85, 217-221.
5. Thompson, F.E. & Byers, T. (1994). Dietary assessment resource manual. The Journal of Nutrition, 124, 2245S-2317S.
6. Wright, J.D., Ervis, B., & Briefel, R.R. (1993). Consensus workshop on dietary assessment: Nutrition monitoring and tracking the year 2000 objectives. Hyattsville: National Center for Health Statistics.
7. Drowugas, H.J. Reed, G., & Hill, J.O. (1992). Comparison of dietary self-reports with energy expenditure measured using a whole-room indirect calorimeter. Journal of the American Dietetic Association, 92, 1073-1077.
8. Todd, K.S., Hudes, M., & Calloway, D.H. (1983). Food intake measurement: Problems and approaches. American Journal of Clinical Nutrition, 37, 139-146.9
9. Feunekes, G.I.J., Van Stavern, W.A., De Vries, J.H.M., Burema, J., & Hautvast, G. J.A.J. (1993). Relative and biomarker-based validity of a food-frequency questionnaire estimating intake of fats and cholesterol. American Journal of Clinical Nutrition, 58, 489-496.
10. Jacques, P.F. Sulsky, S.I., Sadowski, J.A., Phillips, J.C.C., Rush, D., & Willett, W.C. (1993). Comparison of micronutrient intake measured by a dietary questionnaire and biochemical indicators of micronutrient status. American Journal of Clinical Nutrition, 57, 182-189.
11. Willett, W.C., Sampson, L., Stampfer, M.J. et al (1985). Reproducibility and validity of a semiquantitative food frequency questionnaire. American Journal of Epidemiology, 122, 51-65.
12. Feskanich, D., Rimm, E.B., Giovannucci, E.L., Colditz, G.A., Stampfer, M.J., Litin, L.B., & Willett, W.C. (1993). Reproducibility and validity of food intake measurements from a semiquantitative food frequency questionnaire. Journal of the American Dietetic Association, 93, 790-796.
13. Sempos, C.T. (1992). Invited commentary: Some limitations of semiquantitative food frequency questionnaires. American Journal of Epidemiology, 135, 1133-1136.
14. Briefel, R.R., Flegal, K.M., Winn, D.M., Loria, C.M., Johnson, C.L., & Sempos, C.T. (1992). Assessing the nation's diet: Limitations of the food frequency questionnaire. Journal of the American Dietetic Association, 92, 959-962.
15. Cronin, F.J. (1993). Brief indicators of dietary status. in Wright, J.D., Ervis, B., & Briefel, R.R. (Eds.). Consensus workshop on dietary assessment: Nutrition monitoring and tracking the year 2000 objectives. Hyattsville: National Center for Health Statistics (pp 55-90).

16. Kristal, A.R., Shattuck, A.L., Henry, H.J. (1990). Patterns of dietary behavior associated with selecting diets low in fat: Reliability and validity of a behavioral approach to dietary assessment. American Journal of Health Promotion, 4, 288-295.
17. Kristal, A.R., White, E., Shattuck, A.L., Curry, S., Anderson, G.L., Fowler, A., & Urban, N. (1992). Long-term maintenance of a low-fat diet: Durability of fat-related dietary habits in the Women's Health Trial. Journal of the American Dietetic Association, 92, 553-559.
18. Frank, G.C., Nicklas, T.A., Webber, L.S., Major, C., Miller, J.F., & Berenson, G.S. (1992). A food frequency questionnaire for adolescents: Defining eating patterns. Journal of the American Dietetic Association, 92, 313-318.
19. Coates, R.J., Eley, J.W., Block, G, Gunter, E.W., Sowell, A.L., Grossman, C, & Greenberg, R.S. (1991). An evaluation of a food frequency questionnaire for assessing dietary intake of specific carotenoids and vitamin E among low-income black women. American Journal of Epidemiology, 134, 658-671.
20. Buchowski, M.S., Hilton, L.J., Bernard, L, (1995). Dietary assessment in older black men. Sixth Annual Drew-Meharry-Morehouse Consortium Cancer Center Symposium, March 23, 1995, Nashville, TN.
21. Hargreaves, M.K. (1980). Assessment of the validity of four food models. Journal of the Canadian Dietetic Association, 41, 102-110.

Table 1: Outline of focus group protocol

Area	Questions	Area	Questions
Meal Pattern		Food and emotions	Do your moods influence your eating habits? How?
	How often do you eat?		What foods do you eat if you feel good?
	What do you choose?		What foods do you eat if you feel bad?
	What prompts you to make that choice?		How are your snacks influenced by your moods?
	How is your eating different on the weekends?	Purchasing	How often do you shop for your food?
Food preparation	Do you prefer to prepare you meals or eat out?		How do you decide what to buy?
	What is the difference between a meal and a snack?	Food and health beliefs	What do you do to eat healthy foods?
Eating out	How often do you eat out?		Are there foods that do and do not go together?
	What places do you go?		Are there things that are bad for you to eat?
	How do you decide where to go when you want to eat out?		What foods are good for you to eat?
Food, family, and community	How often does your family eat together?		
	What meals are family meal, and when do they occur?		
	How often do you eat at church fellowships? Pot lucks? Picnics?		

□

Table 2: Seven factors of the Final Version of The Eating Behavior Patterns Questionnaire

Factor 1 - Low fat eating

11 items; Mean 31.7; S.D. 8.3; Alpha = .88

- 24. I count fat grams.
- 63. I am very conscious of how much fat is in the food I eat.
- 5. I use low-fat food products.
- 39. I try to limit my intake of red meat (beef and pork).
- 12. I choose healthy foods to prevent heart disease.
- 109. When choosing fast food, I pick a place that offers healthy foods.
- 80. I reduce fat in recipes by substituting ingredients and cutting portions.
- 45. Fish and poultry are the only meats I eat.
- 8. I carefully watch the portion sizes of my foods.
- 14. I eat meatless meals from time to time because I think that is healthier for me.
- 92. I have at least three to four servings of vegetables per day.

Factor 2 - snacking and convenience

10 items; Mean 27.3; S.D. 8.1, Alpha = .86

- 91. I would rather buy take out food and bring it home than cook.
- 25. I eat cookies, candy bars, or ice cream in place of dinner.
- 89. I eat out because it is more convenient than eating at home.
- 97. To me, cookies are an ideal snack food.
- 44. I snack two to three times every day.
- 66. I usually keep cookies in the house
- 23. I am a snacker.
- 84. I have a sweet tooth.
- 26. When I don't plan meals, I eat fast food.
- 86. I sometimes snack even when I am not hungry.

Factor 3 - emotional eating

8 items, mean = 21.5; S.D. = 6.3, alpha = .80

- 20. I eat for comfort.
- 40. When I am in a bad mood, I eat whatever I feel like eating.
- 69. I associate success with food.
- 35. I snack more at night.
- 16. When I buy snack foods, I eat until I have finished the whole package
- 28. I eat when I'm upset.

- 2. My emotions affect what and how much I eat.
- 60. If I am bored, I will snack more

Factor 4 - planning ahead

6 items; Mean = 19.0; S.D. = 4.6, alpha = .71

- 15. I take time to plan meals for the coming week.
- 105. My eating habits are very routine.
- 112. I eat at a fast food restaurant at least three times a week.
- 90. I hate to cook.
- 58. I take a shopping list to the store.
- 42. I never know what I am going to eat for supper when I get up in the morning.

Factor 5 - meal skipping

7 items, mean = 21.2, S.D. = 5.0, alpha = .70

- 56. If I eat a larger than usual lunch, I will skip supper.
- 78. If I am busy, I will eat a snack instead of lunch
- 48. When I am upset, I tend to stop eating.
- 106. If I do not feel hungry, I will skip a meal even if it is time to eat.
- 36. I rarely eat breakfast
- 76. If I eat a larger than usual lunch, I will replace supper with a snack.
- 75. Instead of planning meals, I choose what is available and what I feel like eating.

Factor 6 - Cultural/lifestyle behaviors

9 items, mean 26.1, S.D., 6.5, alpha = .78

- 9. I buy snacks from vending machines.
- 61. I eat at church socials.
- 1. I stop for a fast food breakfast on the way to work.
- 70. A complete meal includes a meat, a starch, a vegetable, and bread.
- 74. On Sunday, I eat a large meal with my family.
- 67. I have a serving of meat at every meal.
- 32. I buy meat every time I go to the grocery store.
- 79. Sometimes I eat dessert more than once a day.
- 51. I like to eat vegetables seasoned with fatty meat.

Table 3: Correlation of Eating Behavior Patterns Questionnaire with selected Nutrient Data

Nutrient	Meal Skipping	Low Fat	Snacking	Emotional Eating	Planning	Cultural
Total Kcal	.18	-.23 *	.31**	.22	.18	.28*
Fat grams	.19	-.33**	.34**	.15	.14	.44***
Sat Fat	.22	-.26*	.30**	.09	.10	.41***
% Kcal Fat	.19	-.42***	.20	-.04	-.01	.53***

Table 4: Relationship between the Eating Behavior Patterns Questionnaire and Nutrient intake for 70 subjects

Nutrient	Mean	S.D.	R	Regression Equation
Total Kcal	2243.4	1104.2	.31	$1194.2 + (43.3 \times \text{snack})$
% Kcal fat	29.6	7.0	.63	$27.8 + (.48 \times \text{culture}) - (.24 \times \text{lowfat}) - (.30 \times \text{emoteat}) + (.16 \times \text{BMI})$
Fat grams	79.3	46.8	.44	$-2.4 + (3.2 \times \text{culture})$
% Kcal protein	18.0	3.7	.36	$18.6 - (.29 \times \text{planning}) + (.13 \times \text{lowfat})$
Protein grams	103.2	47.2	.25	$56.9 + (1.8 \times \text{culture})$
% Kcal Carb	54.1	8.7	.39	$67.8 - (.53 \times \text{culture})$
Carb grams	314.2	151.1	.26	$178.5 + (5.0 \times \text{snack})$
Saturated fat grams	27.9	18.2	.41	$-1.43 + (1.1 \times \text{culture})$
Mono fat grams	29.6	18.3	.53	$15.9 + (1.2 \times \text{culture}) - (.45 \times \text{lowfat})$
Poly fat grams	14.8	8.6	.39	$16.4 + (.24 \times \text{snack}) - (.23 \times \text{lowfat})$
Cholesterol	323.1	204.1	.38	$19.7 + (11.9 \times \text{culture})$
Calcium	863.7	563.3	.34	$-240 + (28.4 \times \text{mealskip}) + (13.4 \times \text{age})$
Iron	21.1	13.3	.43	$-20.2 + (.50 \times \text{emoteat}) + (.91 \times \text{mealskip}) + (.30 \times \text{age})$
Vitamin C	189.0	113.3	-----	
Niacin	32.5	17.3	.40	$-17.6 + (.71 \times \text{emoteat}) + (.97 \times \text{mealskip}) + (.38 \times \text{age})$
Thiamin	2.3	1.3	.40	$-1.5 + (.05 \times \text{emoteat}) + (.08 \times \text{mealskip}) + (.03 \times \text{age})$
Riboflavin	23.1	10.1	.33	$5.1 + (.50 \times \text{emoteat}) + (.19 \times \text{age})$

APPENDIX

Appendix A

Sorted Item Pool Derived From the Focus Groups

Eating Behavior Patterns Questionnaire

Specific Meals

1. My healthiest meal is lunch.
3. I stop for a fast food breakfast on the way to work.
5. I skip breakfast.
6. I don't have time for breakfast in the morning.
8. For breakfast I eat foods that people do not consider breakfast foods.
24. I have only one meal on Sunday.
39. I bring my lunch to work.
11. I pack my lunch at home and bring it to work.
40. My eating habits are the same seven days a week.
61. I eat cookies, candy bars, and ice cream in place of dinner.
68. My healthiest meal is dinner.
69. Due to my schedule I don't have time to eat lunch.
81. I eat meat more than three times per day.
109. A meal consists of a meat, vegetables, starch, and bread.
110. For breakfast I only have time for a cup of coffee and a sweet roll.
127. I have to eat breakfast to get my day started.
138. When growing up there was a regimen of three meals per day.
6. I eat breakfast every day.
7. I rarely eat breakfast
8. I sometimes eat leftovers from the night before for breakfast
9. I always eat regular three meals a day.
17. I do not have time to fix breakfast on a workday.
18. I stop at the drive-up window for breakfast on my way to work.
23. I eat a larger breakfast on the weekends.
24. I tend to eat a late breakfast and skip lunch on the weekends.
25. I skip breakfast on the weekends.
27. If I eat a larger than usual lunch, I will skip supper.
28. If I eat a larger than usual lunch, I will replace supper with a snack.
55. If I am busy, I will eat a snack instead of lunch.
56. My snacks sometimes make it so I do not feel like eating supper.
61. I rarely eat a full meal for supper and instead just have a light snack.
71. I eat fewer meals on the weekend than during the week.
72. I eat larger meals on the weekend than during the week.
74. If I am out running errands on the weekend, I will grab a snack instead of stopping for lunch in order to save time.
103. I often eat cereal for lunch or supper.
109. I basically only eat one real meal per day and the rest of the time I snack.
110. If I do not feel hungry, I will skip a meal even if it is time to eat.
116. I like to eat out for lunch almost every day during the week.
119. I eat more food on the weekends.
124. I love bacon and eggs for breakfast.

Eating Behavior Patterns Questionnaire

Planning

- 2. I take time to plan meals for the coming week.
- 15. I make a healthier food choice when I plan.
- 35. I eat more baked or broiled food when I am able to plan my meals.
- 48. If I don't plan what to eat I stop for fast food.
- 49. I plan my meals the day before.
- 89. When I plan ahead I don't eat as much.
- 99. I eat healthier when I plan.
- 66. I eat healthier foods when I plan ahead.
- 13. I never plan my meals in advance but instead look at what is available and what I feel like eating at the time.
- 20. I look in the pantry to see what I have to decide what to fix for supper.
- 21. I plan meals that I know my family will like.
- 62. The amount of time I have usually influences what I choose to eat.
- 68. When I run out of a food I am used to eating, I usually can find an acceptable substitute rather than running to the store.
- 70. When I leave the house in the morning, I often have no idea of what I am going to do for lunch.
- 78. My eating habits are very routine.
- 79. My eating habits are variable and erratic.
- 105. I work so hard it seems like I don't even have time to eat some days.
- 111. For me, convenience is a big factor in deciding what to eat.
- 114. I almost never know what I am going to have for supper when I get up in the morning.

Eating Behavior Patterns Questionnaire

Family/social

- 4. My family influences what will be prepared.
- 27. The family eats together.
- 29. To honor a family member I cook a way that I normally do not cook in order to please my guests.
- 71. I eat at church socials.
- 72. My co-workers influence me to eat foods that are high in fat.
- 26. On Sunday, I eat a large meal with my family.
- 36. My family eats the evening meal together almost every night.
- 37. My family eats meals together on the weekend, but rarely during the week.
- 38. I attend a potluck at church more than twice a month.
- 48. When I have relatives or guests visiting, I am more likely to fry foods or season vegetables with fat.
- 130. Members of my family are on different schedules so we seldom eat meals together.

Eating Behavior Patterns Questionnaire

Snacking

- 7. I buy snacks from vending machines.
- 1. I snack from vending machines
- 17. I am a snacker.
- 41. I do more snacking during the weekends.
- 54. A snack is something simple and a meal is usually a variety of different foods.
- 73. I find myself snacking all weekend.
- 87. Snacks are seen as necessary.
- 88. Snacks are seen as something extra.
- 95. I snack more at night.
- 96. I snack more during the day.
- 97. When I snack I usually eat one category of things.
- 113. I snack so much at work I sometimes am not hungry for dinner.
- 114. I snack on fruit.
- 115. I snack on popcorn.
- 116. I snack two to three times per day.
- 123. A snack is something you grab on the run.
- 134. When I buy snacks they are gone in a couple of days.
- 135. I have a sweet tooth.
- 2. I sometimes snack even when I am not hungry.
- 3. A snack is something to tide me over until the next meal
- 4. I deliberately try to eat only healthy snacks likes fruit or carrot sticks.
- 5. I like to snack while watching television.
- 10. I eat snacks in addition to my regular meals.
- 54. I could not make it through the day without snacking between meals.
- 57. I love to snack on sweets.
- 59. I eat popcorn as an evening snack.
- 60. There are some days when I eat two or more candy bars.
- 81. To me, cookies are an ideal snack food.
- 82. I would always choose potato chips instead of fruit for a snack if both were available.
- 104. When I am at work, I buy foods from a vending machine to snack on.
- 131. When I buy snack foods, I tend to eat them until I have finished the whole package.

Eating Behavior Patterns Questionnaire

Food Preferences

- 9. I feel better when I eat only vegetables at a meal.
- 10. I eat cake or sweets at least three times during the day.
- 44. I eat fish and milk products together.
- 46. I would rather have sweets than eat a meal.
- 52. Fish and poultry are the only meats I eat.
- 58. I drink fruit juices daily.
- 59. I eat bread at every meal.
- 60. I eat chicken at least three to four times a week.
- 63. I have at least three to four servings of fruit a day.
- 64. I have at least three to four servings of vegetables per day.
- 82. I eat a hamburger every day.
- 83. I eat a hot dog every day.
- 94. There are not many foods I don't like.
- 102. I eat at least four servings of dairy products a day.
- 103. I eat cultural foods such as Chinese and Mexican.
- 104. I eat a lot of starchy foods.
- 132. I am willing to try any food item at least once.
- 133. I will eat half a package of cookies the first day I buy them.
- 139. I only drink or cook with whole milk.
- 42. It just does not seem like a meal unless I eat some meat.
- 43. I try to have a vegetable or piece of fruit at every meal.
- 44. I eat a starch like potatoes, bread, or rice with almost every meal.
- 46. I like to eat vegetables seasoned with fatty meat.
- 49. I like to butter my bread.
- 58. I like to have ice cream during the evening.
- 75. I eat a lot of frozen dinners.
- 76. I usually keep potato chips in the house.
- 77. I usually keep cookies in the house.
- 88. I try to have a serving of meat at every meal.
- 90. A complete meal includes a meat, a starch, a vegetable, and bread.
- 94. I eat more chicken and fish than beef or pork.
- 96. Sometimes I just eat vegetables for a meal.
- 101. I don't think I could ever give up eating cheese.
- 107. Sometimes I eat dessert more than once a day.
- 108. I often go weeks without eating dessert with my meals.
- 125. Mashed potatoes do not seem complete without gravy.
- 126. I enjoy trying foods from different cultures like Chinese, Mexican, Italian, Japanese, and Greek.
- 132. When sweets are sitting around, I cannot resist eating them.
- 132. I have at least one piece of fruit just about every day.

Eating Behavior Patterns Questionnaire

Health awareness

- 11. I read food labels.
- 14. I use low fat food items.
- 28. I watch the portion size of my food.
- 34. I count fat grams.
- 47. I eat healthier when I'm at home because I get to choose what I'm eating.
- 57. The winter months influence my eating habits.
- 65. I look at the cholesterol content of food.
- 66. I read the list of ingredients on the food label.
- 70. I believe that if I drink a diet cola it will balance out the sweets that I eat.
- 90. I feel better when I cook the right way.
- 111. You pay more for lower fat food items.
- 112. You save more money if you buy the regular food item than the low fat item.
- 122. I eat healthier during the week.
- 124. In the last year I have changed my eating habits to be healthier.
- 125. I am interested in becoming a vegetarian.
- 126. I try to limit my intake of pork and red meat.
- 39. I try to avoid red meat.
- 40. I think chocolate is bad for you and one should try not to eat it.
- 41. I would also choose a whole-grain bread over white bread.
- 45. When shopping for food, price is more important than how healthy I think the food might be.
- 63. I read labels to help me decide which foods to buy.
- 64. I always look for the fat content on food labels.
- 65. The sodium content of food will influence my choice of whether or not to eat it.
- 67. I am very conscious of how much fat is in the food I eat.
- 73. I am more careful about choosing healthy foods on the week end.
- 91. I work hard to make sure I get enough protein in my diet.
- 92. Cakes, pies, and other sweets are not good for you.
- 95. I deliberately try to eat meatless meals from time to time because I think that is healthier for me.
- 100. Trying to eat healthy foods is really frustrating.
- 106. I wish I could improve my eating habits.
- 112. I am concerned about eating healthy foods in order to prevent heart disease.
- 115. Where I work the lunch foods available are not very healthy.
- 118. I eat healthier foods on the weekends.
- 135. When I read a label I look at calories, fat, and sodium.

Eating Behavior Patterns Questionnaire

Shopping/purchasing food

- 12. I use coupons.
- 13. I purchase the brands of food that I grew up with.
- 16. I eat out of vending machines
- 20. I tend to purchase the same food items when I go to the store.
- 30. Price is important to me when I go shopping.
- 33. I go to the store when I don't have the specific food I want.
- 38. I buy canned foods.
- 55. The only canned item I buy is tomato sauce.
- 56. I buy only fresh or frozen food items.
- 67. Even though I don't need it I buy a food item just because I have a coupon.
- 74. I use coupons so I can afford the brands I want.
- 75. I buy generic or cost cutter brands.
- 76. I shop at open air markets like farmer's market.
- 78. I buy prepared foods such as casseroles for convenience.
- 79. I only buy brand names.
- 84. I take a shopping list to the store.
- 85. Price determines what food items I buy.
- 86. TV and coupons influence what brands I buy at the store.
- 100. I go to the grocery store when I'm hungry.
- 101. I buy more food when I go to the grocery store hungry.
- 118. I buy ground turkey in place of ground beef.
- 136. I buy in bulk.
- 12. If I am craving a certain food, I will run out to the store to get it if it is not readily available.
- 14. I plan menus and make a list before I go grocery shopping.
- 15. I tend to just buy the same foods when I go to the grocery.
- 16. Whenever I shop, I usually buy myself a treat to eat when I get home.
- 19. I buy food in bulk for home use because it is cheaper.
- 47. When I go to the grocery store, I usually buy enough food to last a week or more.
- 97. I will buy a brand name food that I recognize even if it costs of few cents more.
- 113. I usually only buy enough food at the store to last a couple days.
- 133. I usually wait until I have run out of most foods before I go grocery shopping.
- 134. I buy meat just about every time I go to the grocery store.

Eating Behavior Patterns Questionnaire

Food preparation

- 18. I use spices and herbs to season my food.
- 19. I like to stir fry.
- 21. I explore new ways of cooking.
- 23. I prefer to prepare my meals at home.
- 26. I don't have time to cook on the weekends.
- 36. I eat foods that are easy to prepare.
- 37. I use recipes.
- 42. I use the crock pot to make cooking easier.
- 43. I try new recipes.
- 53. In the summer I BBQ.
- 62. I season my vegetables with fat or fat meat.
- 77. I don't like to cook.
- 80. I eat fried foods daily.
- 91. When I cook I go more by taste rather than a recipe.
- 92. I try to do more baking than frying.
- 105. I am the one who prepares the meals.
- 106. My family participates in meal preparation.
- 107. I steam or boil my vegetables.
- 108. I season my vegetables with margarine or butter.
- 128. On the weekends I do not cook.
- 129. I feel that I need a day off from cooking.
- 137. I freeze leftovers.
- 22. I cook large quantities of food on the weekends and freeze or refridgerate it so I can have quick meals during the week.
- 29. When I cook, I try to find the quickest and easiest way to prepare foods.
- 30. I am adventerous and like to try new recipes.
- 31. I tend to eat the same foods over and over again.
- 32. I use herbs and spices instead of salt when seasoning food.
- 33. I sometimes fry my chicken.
- 80. I steam my vegetables and season them with herbs or lemon juice.
- 83. My cooking is very different than the way my mother cooked.
- 84. If I have to fry something, I use just a little of the vegetable oil spray (e.g., PAM).
- 85. I use the microwave a lot to save time.
- 117. I hate to cook.
- 120. If I am eating alone, I rarely bother cooking an entire meal.
- 121. I would rather get takeout and bring it home than cook.
- 122. I would rather cook at home since that way I know what ingrediants are in the food.
- 127. I alter recipes by making substitutions and cutting portions to lower the fat.

Eating Behavior Patterns Questionnaire

Eating out/fast food/restaurants

- 22. I like to eat out.
- 25. I go out to eat after church on Sunday.
- 50. I eat fast food on the weekend.
- 51. I eat out for convenience.
- 117. I eat out every day for lunch.
- 130. My family eats out three to four times per week.
- 131. I would not cook if I could afford to eat out.
- 34. I eat out a lot to save time.
- 35. My family enjoys eating out more than cooking at home.
- 69. When choosing a fast food restaurant, I think about whether or not I can get healthy food choices there.
- 86. I eat at a fast food restaurant at least three times a week.
- 87. When I eat out, I always eat meat.
- 89. I prefer a sit down restaurant with waiters or waitresses to fast food.
- 93. I stop and get fast food like hamburgers or fried chicken when I am too tired to cook at the end of the day.
- 123. If I could afford it, I would eat almost every meal at a restaurant.
- 128. When I eat out, I order something I would never prepare at home.
- 129. When ordering food in a restaurant, I am very conscious of price.

Eating Behavior Patterns Questionnaire

Emotional

- 31. I eat more when I am emotional.
- 32. During my cycle I crave sweets.
- 45. My mood influences my eating habits.
- 93. When I am stressed I don't eat but when I'm happy I eat.
- 98. If something bothers me I loose my appetite.
- 119. I eat for comfort.
- 120. I eat when I'm upset.
- 121. I associate success with food.
- 50. When I am upset, I tend to stop eating.
- 51. I eat more when I am happy and celebrating.
- 52. When I am upset, I console myself with food.
- 53. My emotions definitely affect what and how much I eat.
- 98. When I am in a bad mood, I am more likely to eat whatever I feel like eating.
- 99. When I have had a hard day, I like to indulge in foods like cookies, candy bars, or ice cream.
- 102. If I am bored, I will snack more.
- 136. If I am upset, I will get a drink of wine or beer to help calm me.

Appendix B

First Version of the Eating Behavior Patterns Questionnaire

Eating Behavior Patterns Questionnaire

Read each item and think if you agree or disagree that the item describes you and your eating habits. Place an "x" in the box that best describes your level of agreement with each statement. If a statement does not apply to you (for example a question asks about what you do at work and you do not have a job), then mark the neutral N/A (not applicable) box.

1. I stop for a fast food breakfast on the way to work.	Strongly Disagree	Disagree	Neutral N/A	Agree	Strongly Agree
2. My emotions affect what and how much I eat.	Strongly Disagree	Disagree	Neutral N/A	Agree	Strongly Agree
3. I read food labels.	Strongly Disagree	Disagree	Neutral N/A	Agree	Strongly Agree
4. I buy generic or cost cutter brands.	Strongly Disagree	Disagree	Neutral N/A	Agree	Strongly Agree
5. I use low-fat food products.	Strongly Disagree	Disagree	Neutral N/A	Agree	Strongly Agree
6. My mood influences my eating habits.	Strongly Disagree	Disagree	Neutral N/A	Agree	Strongly Agree
7. I tend to purchase the same foods each time I go to the store.	Strongly Disagree	Disagree	Neutral N/A	Agree	Strongly Agree
8. I carefully watch the portion sizes of my foods.	Strongly Disagree	Disagree	Neutral N/A	Agree	Strongly Agree
9. I buy snacks from vending machines.	Strongly Disagree	Disagree	Neutral N/A	Agree	Strongly Agree
10. I wish I could improve my eating habits.	Strongly Disagree	Disagree	Neutral N/A	Agree	Strongly Agree
11. If I am craving a certain food, I will go to the store to get it if it is not available.	Strongly Disagree	Disagree	Neutral N/A	Agree	Strongly Agree
12. I choose healthy foods to prevent heart disease.	Strongly Disagree	Disagree	Neutral N/A	Agree	Strongly Agree
13. Where I work the lunch foods available are not very healthy.	Strongly Disagree	Disagree	Neutral N/A	Agree	Strongly Agree
14. I eat meatless meals from time to time because I think that is healthier for me.	Strongly Disagree	Disagree	Neutral N/A	Agree	Strongly Agree
15. I take time to plan meals for the coming week.	Strongly Disagree	Disagree	Neutral N/A	Agree	Strongly Agree
16. When I buy snack foods, I eat until I have finished the whole package.	Strongly Disagree	Disagree	Neutral N/A	Agree	Strongly Agree
17. My family eats meals together on the weekend, but rarely during the week.	Strongly Disagree	Disagree	Neutral N/A	Agree	Strongly Agree

18. I don't have time for breakfast in the morning.	Strongly Disagree	Disagree	Neutral N/A	Agree	Strongly Agree
19. I wait until we are out of most foods before going grocery shopping.	Strongly Disagree	Disagree	Neutral N/A	Agree	Strongly Agree
20. I eat for comfort.	Strongly Disagree	Disagree	Neutral N/A	Agree	Strongly Agree
21. Whenever I shop, I buy myself a treat to eat when I get home.	Strongly Disagree	Disagree	Neutral N/A	Agree	Strongly Agree
22. I pack my lunch at home and bring it to work.	Strongly Disagree	Disagree	Neutral N/A	Agree	Strongly Agree
23. I am a snacker.	Strongly Disagree	Disagree	Neutral N/A	Agree	Strongly Agree
24. I count fat grams.	Strongly Disagree	Disagree	Neutral N/A	Agree	Strongly Agree
25. I eat cookies, candy bars, or ice cream in place of dinner.	Strongly Disagree	Disagree	Neutral N/A	Agree	Strongly Agree
26. When I don't plan meals, I eat fast food.	Strongly Disagree	Disagree	Neutral N/A	Agree	Strongly Agree
27. Due to my schedule I don't have time to eat lunch.	Strongly Disagree	Disagree	Neutral N/A	Agree	Strongly Agree
28. I eat when I'm upset.	Strongly Disagree	Disagree	Neutral N/A	Agree	Strongly Agree
29. I buy enough food at the grocery to last only a couple days.	Strongly Disagree	Disagree	Neutral N/A	Agree	Strongly Agree
30. I use spices and herbs to season my food.	Strongly Disagree	Disagree	Neutral N/A	Agree	Strongly Agree
31. I like to stir fry.	Strongly Disagree	Disagree	Neutral N/A	Agree	Strongly Agree
32. I buy meat every time I go to the grocery store.	Strongly Disagree	Disagree	Neutral N/A	Agree	Strongly Agree
33. I eat meat three times per day.	Strongly Disagree	Disagree	Neutral N/A	Agree	Strongly Agree
34. I have recently changed my eating habits to be healthier.	Strongly Disagree	Disagree	Neutral N/A	Agree	Strongly Agree
35. I snack more at night.	Strongly Disagree	Disagree	Neutral N/A	Agree	Strongly Agree
36. I rarely eat breakfast.	Strongly Disagree	Disagree	Neutral N/A	Agree	Strongly Agree
37. I always eat regular three meals a day.	Strongly Disagree	Disagree	Neutral N/A	Agree	Strongly Agree
38. I don't eat as much when I plan ahead.	Strongly Disagree	Disagree	Neutral N/A	Agree	Strongly Agree

39. I try to limit my intake of red meat (beef and pork).	Strongly Disagree	Disagree	Neutral N/A	Agree	Strongly Agree
40. When I am in a bad mood, I eat whatever I feel like eating.	Strongly Disagree	Disagree	Neutral N/A	Agree	Strongly Agree
41. For me, convenience is a big factor in deciding what to eat.	Strongly Disagree	Disagree	Neutral N/A	Agree	Strongly Agree
42. I never know what I am going to eat for supper when I get up in the morning.	Strongly Disagree	Disagree	Neutral N/A	Agree	Strongly Agree
43. Mashed potatoes do not seem complete without gravy.	Strongly Disagree	Disagree	Neutral N/A	Agree	Strongly Agree
44. I snack two to three times every day.	Strongly Disagree	Disagree	Neutral N/A	Agree	Strongly Agree
45. Fish and poultry are the only meats I eat.	Strongly Disagree	Disagree	Neutral N/A	Agree	Strongly Agree
46. Chocolate is not healthy to eat so I try to avoid it.	Strongly Disagree	Disagree	Neutral N/A	Agree	Strongly Agree
47. I drink fruit juices daily.	Strongly Disagree	Disagree	Neutral N/A	Agree	Strongly Agree
48. When I am upset, I tend to stop eating.	Strongly Disagree	Disagree	Neutral N/A	Agree	Strongly Agree
49. A snack is something you grab on the run.	Strongly Disagree	Disagree	Neutral N/A	Agree	Strongly Agree
50. I eat a starch like potatoes, bread, or rice with almost every meal.	Strongly Disagree	Disagree	Neutral N/A	Agree	Strongly Agree
51. I like to eat vegetables seasoned with fatty meat.	Strongly Disagree	Disagree	Neutral N/A	Agree	Strongly Agree
52. After a hard day, I indulge in sweets like cookies, candy bars, or ice cream.	Strongly Disagree	Disagree	Neutral N/A	Agree	Strongly Agree
53. I like to butter my bread.	Strongly Disagree	Disagree	Neutral N/A	Agree	Strongly Agree
54. When I buy snacks they are gone in a couple of days.	Strongly Disagree	Disagree	Neutral N/A	Agree	Strongly Agree
55. When shopping, price is more important than how healthy the food is.	Strongly Disagree	Disagree	Neutral N/A	Agree	Strongly Agree
56. If I eat a larger than usual lunch, I will skip supper.	Strongly Disagree	Disagree	Neutral N/A	Agree	Strongly Agree
57. I eat more when I am happy and celebrating	Strongly Disagree	Disagree	Neutral N/A	Agree	Strongly Agree
58. I take a shopping list to the store.	Strongly Disagree	Disagree	Neutral N/A	Agree	Strongly Agree
59. Price determines what foods I buy.	Strongly Disagree	Disagree	Neutral N/A	Agree	Strongly Agree

60. If I am bored, I will snack more.	Strongly Disagree	Disagree	Neutral N/A	Agree	Strongly Agree
61. I eat at church socials.	Strongly Disagree	Disagree	Neutral N/A	Agree	Strongly Agree
62. I eat frozen dinners.	Strongly Disagree	Disagree	Neutral N/A	Agree	Strongly Agree
63. I am very conscious of how much fat is in the food I eat.	Strongly Disagree	Disagree	Neutral N/A	Agree	Strongly Agree
64. I usually keep potato chips in the house.	Strongly Disagree	Disagree	Neutral N/A	Agree	Strongly Agree
65. I try hard to get enough protein in my diet.	Strongly Disagree	Disagree	Neutral N/A	Agree	Strongly Agree
66. I usually keep cookies in the house.	Strongly Disagree	Disagree	Neutral N/A	Agree	Strongly Agree
67. I have a serving of meat at every meal.	Strongly Disagree	Disagree	Neutral N/A	Agree	Strongly Agree
68. When eating alone, I rarely bother cooking an entire meal.	Strongly Disagree	Disagree	Neutral N/A	Agree	Strongly Agree
69. I associate success with food.	Strongly Disagree	Disagree	Neutral N/A	Agree	Strongly Agree
70. A complete meal includes a meat, a starch, a vegetable, and bread.	Strongly Disagree	Disagree	Neutral N/A	Agree	Strongly Agree
71. My co-workers influence me to eat foods that are high in fat.	Strongly Disagree	Disagree	Neutral N/A	Agree	Strongly Agree
72. When I am upset, I console myself with food.	Strongly Disagree	Disagree	Neutral N/A	Agree	Strongly Agree
73. I tend to eat the same foods over and over again.	Strongly Disagree	Disagree	Neutral N/A	Agree	Strongly Agree
74. On Sunday, I eat a large meal with my family.	Strongly Disagree	Disagree	Neutral N/A	Agree	Strongly Agree
75. Instead of planning meals, I choose what is available and what I feel like eating.	Strongly Disagree	Disagree	Neutral N/A	Agree	Strongly Agree
76. If I eat a larger than usual lunch, I will replace supper with a snack.	Strongly Disagree	Disagree	Neutral N/A	Agree	Strongly Agree
77. Sometimes I just eat vegetables for a meal.	Strongly Disagree	Disagree	Neutral N/A	Agree	Strongly Agree
78. If I am busy, I will eat a snack instead of lunch.	Strongly Disagree	Disagree	Neutral N/A	Agree	Strongly Agree
79. Sometimes I eat dessert more than once a day.	Strongly Disagree	Disagree	Neutral N/A	Agree	Strongly Agree
80. I reduce fat in recipes by substituting ingredients and cutting portions.	Strongly Disagree	Disagree	Neutral N/A	Agree	Strongly Agree

81. I rarely eat a full meal for supper and instead just have a light snack.	Strongly Disagree	Disagree	Neutral N/A	Agree	Strongly Agree
82. If I am upset, I will get a drink of wine or beer to help calm me.	Strongly Disagree	Disagree	Neutral N/A	Agree	Strongly Agree
83. I eat larger meals on the weekend than during the week.	Strongly Disagree	Disagree	Neutral N/A	Agree	Strongly Agree
84. I have a sweet tooth.	Strongly Disagree	Disagree	Neutral N/A	Agree	Strongly Agree
85. I steam my vegetables and season them with herbs or lemon juice.	Strongly Disagree	Disagree	Neutral N/A	Agree	Strongly Agree
86. I sometimes snack even when I am not hungry.	Strongly Disagree	Disagree	Neutral N/A	Agree	Strongly Agree
87. I eat at least three to four servings of fruit a day.	Strongly Disagree	Disagree	Neutral N/A	Agree	Strongly Agree
88. I use the microwave a lot to save time.	Strongly Disagree	Disagree	Neutral N/A	Agree	Strongly Agree
89. I eat out because it is more convenient than eating at home.	Strongly Disagree	Disagree	Neutral N/A	Agree	Strongly Agree
90. I hate to cook.	Strongly Disagree	Disagree	Neutral N/A	Agree	Strongly Agree
91. I would rather buy take out food and bring it home than cook.	Strongly Disagree	Disagree	Neutral N/A	Agree	Strongly Agree
92. I have at least three to four servings of vegetables per day.	Strongly Disagree	Disagree	Neutral N/A	Agree	Strongly Agree
93. A snack is something to tide me over until the next meal.	Strongly Disagree	Disagree	Neutral N/A	Agree	Strongly Agree
94. How busy I am influences what I choose to eat.	Strongly Disagree	Disagree	Neutral N/A	Agree	Strongly Agree
95. I often eat cereal for lunch or supper.	Strongly Disagree	Disagree	Neutral N/A	Agree	Strongly Agree
96. When I cook, I find the quickest and easiest way to prepare foods.	Strongly Disagree	Disagree	Neutral N/A	Agree	Strongly Agree
97. To me, cookies are an ideal snack food.	Strongly Disagree	Disagree	Neutral N/A	Agree	Strongly Agree
98. I choose potato chips instead of fruit as a snack when both available.	Strongly Disagree	Disagree	Neutral N/A	Agree	Strongly Agree
99. If I could afford it, I would eat almost every meal at a restaurant.	Strongly Disagree	Disagree	Neutral N/A	Agree	Strongly Agree

100. I will eat half a package of cookies the first day I buy them.	Strongly Disagree	Disagree	Neutral N/A	Agree	Strongly Agree
101. I only drink or cook with whole milk.	Strongly Disagree	Disagree	Neutral N/A	Agree	Strongly Agree
102. When ordering food in a restaurant, I am very conscious of price.	Strongly Disagree	Disagree	Neutral N/A	Agree	Strongly Agree
103. It just does not seem like a meal unless I eat some meat.	Strongly Disagree	Disagree	Neutral N/A	Agree	Strongly Agree
104. When leaving home in the morning, I don't know what I will eat for lunch.	Strongly Disagree	Disagree	Neutral N/A	Agree	Strongly Agree
105. My eating habits are very routine.	Strongly Disagree	Disagree	Neutral N/A	Agree	Strongly Agree
106. If I do not feel hungry, I will skip a meal even if it is time to eat.	Strongly Disagree	Disagree	Neutral N/A	Agree	Strongly Agree
107. I like to eat out for lunch almost every day during the week.	Strongly Disagree	Disagree	Neutral N/A	Agree	Strongly Agree
108. I eat only healthy snacks likes fruit or carrot sticks.	Strongly Disagree	Disagree	Neutral N/A	Agree	Strongly Agree
109. When choosing fast food, I pick a place that offers healthy foods.	Strongly Disagree	Disagree	Neutral N/A	Agree	Strongly Agree
110. I like to snack while watching television.	Strongly Disagree	Disagree	Neutral N/A	Agree	Strongly Agree
111. I prefer to prepare my meals at home.	Strongly Disagree	Disagree	Neutral N/A	Agree	Strongly Agree
112. I eat at a fast food restaurant at least three times a week.	Strongly Disagree	Disagree	Neutral N/A	Agree	Strongly Agree
113. When I eat out, I always eat meat.	Strongly Disagree	Disagree	Neutral N/A	Agree	Strongly Agree

Appendix C

Revised Version of the Eating Behavior Patterns Questionnaire Used in Phase III

Eating Behavior Patterns Questionnaire - Revised

Read each item and think if you agree or disagree that the item describes you and your eating habits. Place an "x" in the box that best describes your level of agreement with each statement. If a statement does not apply to you (for example a question asks about what you do at work and you do not have a job), then mark the neutral N/A (not applicable) box.

1. I stop for a fast food breakfast on the way to work.	Strongly Disagree	Disagree	Neutral N/A	Agree	Strongly Agree
2. My emotions affect what and how much I eat.	Strongly Disagree	Disagree	Neutral N/A	Agree	Strongly Agree
3. I use low-fat food products.	Strongly Disagree	Disagree	Neutral N/A	Agree	Strongly Agree
4. I carefully watch the portion sizes of my foods.	Strongly Disagree	Disagree	Neutral N/A	Agree	Strongly Agree
5. I buy snacks from vending machines.	Strongly Disagree	Disagree	Neutral N/A	Agree	Strongly Agree
6. I choose healthy foods to prevent heart disease.	Strongly Disagree	Disagree	Neutral N/A	Agree	Strongly Agree
7. I eat meatless meals from time to time because I think that is healthier for me.	Strongly Disagree	Disagree	Neutral N/A	Agree	Strongly Agree
8. I take time to plan meals for the coming week.	Strongly Disagree	Disagree	Neutral N/A	Agree	Strongly Agree
9. When I buy snack foods, I eat until I have finished the whole package.	Strongly Disagree	Disagree	Neutral N/A	Agree	Strongly Agree
10. I eat for comfort.	Strongly Disagree	Disagree	Neutral N/A	Agree	Strongly Agree
11. I am a snacker.	Strongly Disagree	Disagree	Neutral N/A	Agree	Strongly Agree
12. I count fat grams.	Strongly Disagree	Disagree	Neutral N/A	Agree	Strongly Agree
13. I eat cookies, candy bars, or ice cream in place of dinner.	Strongly Disagree	Disagree	Neutral N/A	Agree	Strongly Agree
14. When I don't plan meals, I eat fast food.	Strongly Disagree	Disagree	Neutral N/A	Agree	Strongly Agree
15. I eat when I'm upset.	Strongly Disagree	Disagree	Neutral N/A	Agree	Strongly Agree
16. I buy meat every time I go to the grocery store.	Strongly Disagree	Disagree	Neutral N/A	Agree	Strongly Agree
17. I snack more at night.	Strongly Disagree	Disagree	Neutral N/A	Agree	Strongly Agree
18. I rarely eat breakfast.	Strongly Disagree	Disagree	Neutral N/A	Agree	Strongly Agree

19.	I try to limit my intake of red meat (beef and pork).	Strongly Disagree	Disagree	Neutral N/A	Agree	Strongly Agree
20.	When I am in a bad mood, I eat whatever I feel like eating.	Strongly Disagree	Disagree	Neutral N/A	Agree	Strongly Agree
21.	I never know what I am going to eat for supper when I get up in the morning.	Strongly Disagree	Disagree	Neutral N/A	Agree	Strongly Agree
22.	I snack two to three times every day.	Strongly Disagree	Disagree	Neutral N/A	Agree	Strongly Agree
23.	Fish and poultry are the only meats I eat.	Strongly Disagree	Disagree	Neutral N/A	Agree	Strongly Agree
24.	When I am upset, I tend to stop eating.	Strongly Disagree	Disagree	Neutral N/A	Agree	Strongly Agree
25.	I like to eat vegetables seasoned with fatty meat.	Strongly Disagree	Disagree	Neutral N/A	Agree	Strongly Agree
26.	If I eat a larger than usual lunch, I will skip supper.	Strongly Disagree	Disagree	Neutral N/A	Agree	Strongly Agree
27.	I take a shopping list to the store.	Strongly Disagree	Disagree	Neutral N/A	Agree	Strongly Agree
28.	If I am bored, I will snack more.	Strongly Disagree	Disagree	Neutral N/A	Agree	Strongly Agree
29.	I eat at church socials.	Strongly Disagree	Disagree	Neutral N/A	Agree	Strongly Agree
30.	I am very conscious of how much fat is in the food I eat.	Strongly Disagree	Disagree	Neutral N/A	Agree	Strongly Agree
31.	I usually keep cookies in the house.	Strongly Disagree	Disagree	Neutral N/A	Agree	Strongly Agree
32.	I have a serving of meat at every meal.	Strongly Disagree	Disagree	Neutral N/A	Agree	Strongly Agree
33.	I associate success with food.	Strongly Disagree	Disagree	Neutral N/A	Agree	Strongly Agree
34.	A complete meal includes a meat, a starch, a vegetable, and bread.	Strongly Disagree	Disagree	Neutral N/A	Agree	Strongly Agree
35.	On Sunday, I eat a large meal with my family.	Strongly Disagree	Disagree	Neutral N/A	Agree	Strongly Agree
36.	Instead of planning meals, I choose what is available and what I feel like eating.	Strongly Disagree	Disagree	Neutral N/A	Agree	Strongly Agree
37.	If I eat a larger than usual lunch, I will replace supper with a snack.	Strongly Disagree	Disagree	Neutral N/A	Agree	Strongly Agree
38.	If I am busy, I will eat a snack instead of lunch.	Strongly Disagree	Disagree	Neutral N/A	Agree	Strongly Agree
39.	Sometimes I eat dessert more than once a day.	Strongly Disagree	Disagree	Neutral N/A	Agree	Strongly Agree

40.	I reduce fat in recipes by substituting ingredients and cutting portions.	Strongly Disagree	Disagree	Neutral N/A	Agree	Strongly Agree
42.	I have a sweet tooth.	Strongly Disagree	Disagree	Neutral N/A	Agree	Strongly Agree
43.	I sometimes snack even when I am not hungry.	Strongly Disagree	Disagree	Neutral N/A	Agree	Strongly Agree
44.	I eat out because it is more convenient than eating at home.	Strongly Disagree	Disagree	Neutral N/A	Agree	Strongly Agree
45.	I hate to cook.	Strongly Disagree	Disagree	Neutral N/A	Agree	Strongly Agree
46.	I would rather buy take out food and bring it home than cook.	Strongly Disagree	Disagree	Neutral N/A	Agree	Strongly Agree
47.	I have at least three to four servings of vegetables per day.	Strongly Disagree	Disagree	Neutral N/A	Agree	Strongly Agree
48.	To me, cookies are an ideal snack food.	Strongly Disagree	Disagree	Neutral N/A	Agree	Strongly Agree
49.	My eating habits are very routine.	Strongly Disagree	Disagree	Neutral N/A	Agree	Strongly Agree
50.	If I do not feel hungry, I will skip a meal even if it is time to eat.	Strongly Disagree	Disagree	Neutral N/A	Agree	Strongly Agree
51.	When choosing fast food, I pick a place that offers healthy foods.	Strongly Disagree	Disagree	Neutral N/A	Agree	Strongly Agree
52.	I eat at a fast food restaurant at least three times a week.	Strongly Disagree	Disagree	Neutral N/A	Agree	Strongly Agree

Appendix D

The Meharry Food Frequency Questionnaire

Meharry Food Frequency Questionnaire

The following pages are a questionnaire to help us understand your usual dietary intake. Each line of the questionnaire is a food that many people eat. Think about your habits over the past month, and tell us how often you have eaten that particular food. There are boxes to the right of each food and in each box is a possible answer to how often you consume each food. Place an "X" in the box that best describes how often you have eaten each food during the past month. Do not leave any items blank.

How to Answer the Questionnaire	
Never	I did not eat this food at all during the past month
1/mo	I ate this food once during the past month
2-3/mo	I ate this food 2 or 3 times during the past month
1-2/wk	I ate this food 1 or 2 times a week during the past month
3-4/wk	I ate this food 3 or 4 times a week during the past month
5-6/wk	I ate this food 5 or 6 times a week during the past month
1/day	I ate this food once a day during the past month
2/day	I ate this food twice a day during the past month
3+/day	I ate this food three or more times a day during the past month

Before starting the questionnaire, we want to know more about you and your background.

1. How old are you? _____

2. What is your height.

Height: ____ feet ____ inches

3. How much do you weigh in pounds? It is critical for our evaluation that your weight be as accurate as possible.

Weight: _____

4. What gender are you?

____ Male
 ____ Female

5. I would describe myself as:

____ White
 ____ Black
 ____ Hispanic
 ____ Oriental
 ____ Native American
 ____ Other

6. What grade are you in? If you are not currently in school, what was the highest grade you completed (check one)?

____ Primary school (grade 1 through 6)
 ____ 7th- 8th grade
 ____ 9th - 11th grade
 ____ 12th grade, high school graduate
 ____ Some college
 ____ College graduate
 ____ Graduate or professional school

How often do you eat each of these foods?

Monthly

Weekly

Daily

MEATS	Monthly			Weekly			Daily		
	Never	1/mo	2-3/mo	1-2/wk	3-4/wk	5-6/wk	1/day	2/day	3+/day
1. Hamburger									
2. Hamburger, ground round (extra lean)									
3. Steak, roast beef									
4. Meatloaf									
5. Ham									
6. Pork chops, pork roast									
7. Chitterlings									
8. Pigs feet, pigs ears									
9. Bacon									
10. Pork backs									
11. Sausage (links, patties)									
12. Sausage - low fat									
13. Slim Jim/beef jerky									
14. Hot dogs									
15. Hot dogs (low fat, reduced fat)									
16. Sliced Roast beef, sliced ham									
17. Sliced turkey/chicken									
18. Bologna/salami/lunch meats									
19. Low-fat lunch meats (e.g. turkey ham)									
20. Fried chicken									
21. Baked/boiled/broiled chicken									
22. Ground turkey									
23. Baked turkey									
24. Fried fish									
25. Baked/broiled/grilled fish									
26. Tuna/salmon canned in oil.									
27. Tuna/salmon canned in water									

How often do you eat each of these foods?

Monthly

Weekly

Daily

MILK, CHEESE, DAIRY	Monthly			Weekly			Daily		
	Never	1/mo	2-3/mo	1-2/wk	3-4/wk	5-6/wk	1/day	2/day	3+/day
28. Cottage Cheese (4% milk fat)	Never	1/mo	2-3/mo	1-2/wk	3-4/wk	5-6/wk	1/day	2/day	3+/day
29. Cottage cheese (low-fat or fat free)	Never	1/mo	2-3/mo	1-2/wk	3-4/wk	5-6/wk	1/day	2/day	3+/day
30. Swiss, Colby, cheddar, jack, American	Never	1/mo	2-3/mo	1-2/wk	3-4/wk	5-6/wk	1/day	2/day	3+/day
31. Reduced fat Swiss, cheddar, American	Never	1/mo	2-3/mo	1-2/wk	3-4/wk	5-6/wk	1/day	2/day	3+/day
32. Fat free Swiss, cheddar, American	Never	1/mo	2-3/mo	1-2/wk	3-4/wk	5-6/wk	1/day	2/day	3+/day
33. Mozzarella	Never	1/mo	2-3/mo	1-2/wk	3-4/wk	5-6/wk	1/day	2/day	3+/day
34. Fat-free mozzarella	Never	1/mo	2-3/mo	1-2/wk	3-4/wk	5-6/wk	1/day	2/day	3+/day
35. Parmesan cheese	Never	1/mo	2-3/mo	1-2/wk	3-4/wk	5-6/wk	1/day	2/day	3+/day
36. Parmesan (fat free)	Never	1/mo	2-3/mo	1-2/wk	3-4/wk	5-6/wk	1/day	2/day	3+/day
37. Cream cheese	Never	1/mo	2-3/mo	1-2/wk	3-4/wk	5-6/wk	1/day	2/day	3+/day
38. Cream cheese (fat free)	Never	1/mo	2-3/mo	1-2/wk	3-4/wk	5-6/wk	1/day	2/day	3+/day
39. Yogurt (regular, low fat)	Never	1/mo	2-3/mo	1-2/wk	3-4/wk	5-6/wk	1/day	2/day	3+/day
40. Yogurt (fat free)	Never	1/mo	2-3/mo	1-2/wk	3-4/wk	5-6/wk	1/day	2/day	3+/day
41. Sour cream	Never	1/mo	2-3/mo	1-2/wk	3-4/wk	5-6/wk	1/day	2/day	3+/day
42. Sour cream (fat free)	Never	1/mo	2-3/mo	1-2/wk	3-4/wk	5-6/wk	1/day	2/day	3+/day
43. Milk (whole milk, 4%)	Never	1/mo	2-3/mo	1-2/wk	3-4/wk	5-6/wk	1/day	2/day	3+/day
44. Milk (2% milk fat)	Never	1/mo	2-3/mo	1-2/wk	3-4/wk	5-6/wk	1/day	2/day	3+/day
45. Milk (1- 1/2 % milk fat)	Never	1/mo	2-3/mo	1-2/wk	3-4/wk	5-6/wk	1/day	2/day	3+/day
46. Milk (skim)	Never	1/mo	2-3/mo	1-2/wk	3-4/wk	5-6/wk	1/day	2/day	3+/day
47. Buttermilk	Never	1/mo	2-3/mo	1-2/wk	3-4/wk	5-6/wk	1/day	2/day	3+/day
48. Chocolate milk	Never	1/mo	2-3/mo	1-2/wk	3-4/wk	5-6/wk	1/day	2/day	3+/day
49. Coffee creamer, half-and-half	Never	1/mo	2-3/mo	1-2/wk	3-4/wk	5-6/wk	1/day	2/day	3+/day
50. Coffee creamer (fat free)	Never	1/mo	2-3/mo	1-2/wk	3-4/wk	5-6/wk	1/day	2/day	3+/day
51. Ice cream	Never	1/mo	2-3/mo	1-2/wk	3-4/wk	5-6/wk	1/day	2/day	3+/day
52. Ice milk, frozen yogurt, sherbet	Never	1/mo	2-3/mo	1-2/wk	3-4/wk	5-6/wk	1/day	2/day	3+/day
53. Eggs	Never	1/mo	2-3/mo	1-2/wk	3-4/wk	5-6/wk	1/day	2/day	3+/day
54. Egg beaters, egg substitute	Never	1/mo	2-3/mo	1-2/wk	3-4/wk	5-6/wk	1/day	2/day	3+/day

How often do you eat each of these foods?

Monthly

Weekly

Daily

FRUITS	Monthly			Weekly			Daily		
	Never	1/mo	2-3/mo	1-2/wk	3-4/wk	5-6/wk	1/day	2/day	3+/day
55. Oranges, grapefruits, lemons, limes	Never	1/mo	2-3/mo	1-2/wk	3-4/wk	5-6/wk	1/day	2/day	3+/day
56. Apples	Never	1/mo	2-3/mo	1-2/wk	3-4/wk	5-6/wk	1/day	2/day	3+/day
57. Pears, peaches, apricots, plums	Never	1/mo	2-3/mo	1-2/wk	3-4/wk	5-6/wk	1/day	2/day	3+/day
58. Grapes	Never	1/mo	2-3/mo	1-2/wk	3-4/wk	5-6/wk	1/day	2/day	3+/day
59. Bananas	Never	1/mo	2-3/mo	1-2/wk	3-4/wk	5-6/wk	1/day	2/day	3+/day
60. Melon (cantaloupe, watermelon, etc.)	Never	1/mo	2-3/mo	1-2/wk	3-4/wk	5-6/wk	1/day	2/day	3+/day
61. Berries (blueberries, strawberries, etc.)	Never	1/mo	2-3/mo	1-2/wk	3-4/wk	5-6/wk	1/day	2/day	3+/day
62. Dried fruit (apricots, prunes, etc.)	Never	1/mo	2-3/mo	1-2/wk	3-4/wk	5-6/wk	1/day	2/day	3+/day
63. Raisins	Never	1/mo	2-3/mo	1-2/wk	3-4/wk	5-6/wk	1/day	2/day	3+/day
64. Fruit juices (e.g., orange, apple, grape)	Never	1/mo	2-3/mo	1-2/wk	3-4/wk	5-6/wk	1/day	2/day	3+/day
VEGETABLES	Monthly			Weekly			Daily		
65. Peppers (red, green, hot)	Never	1/mo	2-3/mo	1-2/wk	3-4/wk	5-6/wk	1/day	2/day	3+/day
66. Squash (e.g. butternut, zucchini, yellow)	Never	1/mo	2-3/mo	1-2/wk	3-4/wk	5-6/wk	1/day	2/day	3+/day
67. Green beans	Never	1/mo	2-3/mo	1-2/wk	3-4/wk	5-6/wk	1/day	2/day	3+/day
68. Peas, blackeyed peas	Never	1/mo	2-3/mo	1-2/wk	3-4/wk	5-6/wk	1/day	2/day	3+/day
69. Corn (canned, frozen, on the cob)	Never	1/mo	2-3/mo	1-2/wk	3-4/wk	5-6/wk	1/day	2/day	3+/day
70. Carrots (cooked and raw)	Never	1/mo	2-3/mo	1-2/wk	3-4/wk	5-6/wk	1/day	2/day	3+/day
71. Cabbage, broccoli, cauliflower, kale	Never	1/mo	2-3/mo	1-2/wk	3-4/wk	5-6/wk	1/day	2/day	3+/day
72. Mushrooms	Never	1/mo	2-3/mo	1-2/wk	3-4/wk	5-6/wk	1/day	2/day	3+/day
73. Potatoes (baked, mashed, instant, etc.)	Never	1/mo	2-3/mo	1-2/wk	3-4/wk	5-6/wk	1/day	2/day	3+/day
74. Sweet potatoes, yams	Never	1/mo	2-3/mo	1-2/wk	3-4/wk	5-6/wk	1/day	2/day	3+/day
75. Onions	Never	1/mo	2-3/mo	1-2/wk	3-4/wk	5-6/wk	1/day	2/day	3+/day
76. Lettuce, celery	Never	1/mo	2-3/mo	1-2/wk	3-4/wk	5-6/wk	1/day	2/day	3+/day
77. Greens (collar, mustard, spinach)	Never	1/mo	2-3/mo	1-2/wk	3-4/wk	5-6/wk	1/day	2/day	3+/day
78. Kidney, pinto, black, northern beans	Never	1/mo	2-3/mo	1-2/wk	3-4/wk	5-6/wk	1/day	2/day	3+/day
79. Okra	Never	1/mo	2-3/mo	1-2/wk	3-4/wk	5-6/wk	1/day	2/day	3+/day
80. Turnips	Never	1/mo	2-3/mo	1-2/wk	3-4/wk	5-6/wk	1/day	2/day	3+/day

How often do you eat each of these foods?

Monthly

Weekly

Daily

	Monthly			Weekly			Daily		
	Never	1/mo	2-3/mo	1-2/wk	3-4/wk	5-6/wk	1/day	2/day	3+/day
CONDIMENTS, SPREADS	<input type="checkbox"/>								
108. Peanut butter	Never	1/mo	2-3/mo	1-2/wk	3-4/wk	5-6/wk	1/day	2/day	3+/day
109. Jelly or Jams	Never	1/mo	2-3/mo	1-2/wk	3-4/wk	5-6/wk	1/day	2/day	3+/day
110. Syrup, honey	Never	1/mo	2-3/mo	1-2/wk	3-4/wk	5-6/wk	1/day	2/day	3+/day
111. Butter or margarine	Never	1/mo	2-3/mo	1-2/wk	3-4/wk	5-6/wk	1/day	2/day	3+/day
112. Reduced fat margarine	Never	1/mo	2-3/mo	1-2/wk	3-4/wk	5-6/wk	1/day	2/day	3+/day
113. Salad dressing, mayonnaise	Never	1/mo	2-3/mo	1-2/wk	3-4/wk	5-6/wk	1/day	2/day	3+/day
114. Salad dressing, mayonnaise (fat free)	Never	1/mo	2-3/mo	1-2/wk	3-4/wk	5-6/wk	1/day	2/day	3+/day
115. Gravy, cheese sauces	Never	1/mo	2-3/mo	1-2/wk	3-4/wk	5-6/wk	1/day	2/day	3+/day
116. Fat or fat meat added to vegetables	Never	1/mo	2-3/mo	1-2/wk	3-4/wk	5-6/wk	1/day	2/day	3+/day
BEVERAGES	<input type="checkbox"/>								
117. Sugared soft-drinks (e.g., coke, sprite)	Never	1/mo	2-3/mo	1-2/wk	3-4/wk	5-6/wk	1/day	2/day	3+/day
118. Sugar free soft-drinks (e.g., diet coke)	Never	1/mo	2-3/mo	1-2/wk	3-4/wk	5-6/wk	1/day	2/day	3+/day
119. Ice tea, hot tea, herbal teas	Never	1/mo	2-3/mo	1-2/wk	3-4/wk	5-6/wk	1/day	2/day	3+/day
120. Kool-aid, lemon-aid, punch	Never	1/mo	2-3/mo	1-2/wk	3-4/wk	5-6/wk	1/day	2/day	3+/day
121. Sugar free kool-aid, punch	Never	1/mo	2-3/mo	1-2/wk	3-4/wk	5-6/wk	1/day	2/day	3+/day
122. Beer, wine, wine coolers, mixed drinks	Never	1/mo	2-3/mo	1-2/wk	3-4/wk	5-6/wk	1/day	2/day	3+/day
FAST FOOD, CONVENIENCE FOOD	<input type="checkbox"/>								
123. Hamburger/cheeseburger (regular)	Never	1/mo	2-3/mo	1-2/wk	3-4/wk	5-6/wk	1/day	2/day	3+/day
124. Deluxe burgers (Big Mac, whopper)	Never	1/mo	2-3/mo	1-2/wk	3-4/wk	5-6/wk	1/day	2/day	3+/day
125. French fries/hash browns	Never	1/mo	2-3/mo	1-2/wk	3-4/wk	5-6/wk	1/day	2/day	3+/day
126. Pizza	Never	1/mo	2-3/mo	1-2/wk	3-4/wk	5-6/wk	1/day	2/day	3+/day
127. Mexican food	Never	1/mo	2-3/mo	1-2/wk	3-4/wk	5-6/wk	1/day	2/day	3+/day
128. Chinese food	Never	1/mo	2-3/mo	1-2/wk	3-4/wk	5-6/wk	1/day	2/day	3+/day
129. Breakfast sandwich (steak biscuit)	Never	1/mo	2-3/mo	1-2/wk	3-4/wk	5-6/wk	1/day	2/day	3+/day
130. Submarine sandwich	Never	1/mo	2-3/mo	1-2/wk	3-4/wk	5-6/wk	1/day	2/day	3+/day

**D. DEVELOPMENT OF THE DIETARY
INTERVENTION MANUAL**

Purpose

The purpose of these activities was to develop a dietary intervention that would lead to the reduction of fat intake in middle to high income African American women to a reported level of less than 25% of daily calorie intake.

Procedures

Participants were those who had been subjects in the first focus groups in Year 1, in which information was gathered about the characteristics of the African American diet, barriers to, and facilitators of change.

The initial stages of the intervention included development of an outline of information using Prochaska's principles of change. A facilitator's manual would be developed for the intervention with guidelines for sessions with each stage of change group. Dietary intervention focus groups were designed for subjects to provide feedback and assist in development of the intervention. Subjects were brought together by stage of change and asked to respond to the proposed intervention processes. Existing NIH materials, including ones specifically designed for low literacy and African American audiences were presented, and reactions obtained.

Dietary intervention focus group sessions were conducted in the project's offices over the lunch hour with lunch provided. This was designed to meet the convenience of employed subjects. The lunch reflected the dietary principles being advocated by the project. The sessions were scheduled for one hour, but ranged from seventy-five minutes to ninety minutes in length.

After introductions, subjects were asked to pledge to keep all comments and information shared during the group confidential to the group; they were assured that all subject information in the project would be held confidential by the project. Subjects' prior stage of change levels were verified and the project was re-introduced, followed by information about its role in disease prevention.

The challenges presented by dietary changes were acknowledged and opportunity was provided for subjects to voice opinions, share information and to interact. Subjects were presented with up to a total of seven pieces of printed material and asked to judge the relevance of each to individuals in similar stages of dietary change; subjects were also asked whether the piece should be recommended for use in the project. The project materials are listed in Table 1.

Information provided to focus group participants also included the goal of gradually reaching 20-25 gms of fiber intake daily, as a part of the effort to reduce fat. Finally, subjects were asked if they would like to make a commitment to change and were told the project appreciated their assistance and would want to contact them later for further advice and counsel. Each subject was given a five dollar token of appreciation for participation. Each focus group session was recorded on tape and transcribed. Participating subjects were contacted the next month and asked for any additional thoughts they might want to provide to the project. Subjects were also asked if they had begun any new dietary behaviors.

Results

Focus group sessions provided much valuable information for the project. While the precontemplators were a little more resistant to change, all five stage of change groups expressed value for the work of the study and the need to have a healthier diet. Even precontemplators were aware of the hazards of being obese and not eating right. Their level of awareness provided a springboard for transitioning this acknowledgement into action plans to consider in facilitating behavior change.

Another area which seems to be basically consistent with all five groups was the value of getting together and talking about their diet questions, struggles and ideas. This sharing and camaraderie seem to have a lot of value. When the facilitator indicated that "someone" from the study would be in contact with them soon, the subjects immediately began expressing excitement about receiving help directly from the facilitator, raising the issues of trust and continuity between project staff and subjects. When subjects were later telephoned, their responses indicated that the call was appreciated and they freely shared progress on their dietary change endeavor.

All five groups were incredibly honest regarding current diet-related attitudes as well as food selection and preparation habits. Their responses reflected their individual realities. Some subjects were living with families and some were living alone while others were still at home with parents and did not have responsibility for food preparation.

Precontemplators, contemplators and preparers were very receptive to learning more about making the transition to a low fat diet. The groups asked more basic questions regarding current habits, often continuing their inquiries after the session had formally ended. Subjects were always quick to bring attention to any behavior in the presentation materials which had already been incorporated into their lifestyles, and the facilitator would acknowledge that their change process had begun, even when it was on a small scale. Subjects at these earlier stages of change commented that while they might not go home and make a particular low fat dish or meal, they would try one if it were prepared by someone else; they suggested tasting sessions within the project intervention procedures.

Acters and maintainers were very vocal regarding their needs for support, demonstrating independence, especially in sharing among themselves and responding to each other's comments and questions. Their knowledge about dietary fat and how to avoid it was factual and strong. However, they tended to listen more attentively to and take more notes on information about increasing dietary fiber as another strategy to reduce dietary fat. The fiber information was well received. Subjects at these two more advanced stages of dietary change were very concerned about and interested in recipes and food preparation techniques. Maintainers chose not to be telephoned by the project. Instead, they wanted to meet occasionally and to have recipes, menu ideas and low fat food preparation suggestions regularly mailed to them from the project. Acters and maintainers expressed a willingness to participate in sessions with women at earlier stages of dietary change to serve as role models and assistants in the sessions. The responses and

recommendations made by the focus group subjects are summarized in Tables 2 & 3. Table 4 shows the focus group responses to each piece of health promotion material presented.

Discussion

It is evident that subjects enjoy interaction with others of like mind and experience and as a result, they recommended an intensive and multi-faceted program of activity for the intervention. Subjects at all stages are interested in meeting several times; they are also interested in receiving relevant literature from the project. Most want periodic telephone calls as well. All of the comments seemed very candid and frank. The facilitator utilized personal testimony and postured herself as one who is still struggling right along with others to make improvements. This may have set the stage for others to be open and candid. Positive reinforcement of the subject behaviors which promote lower fat intake seems to have sound value. The acknowledgement that the change process had already begun, even if on a small scale, seemed to be motivational.

By emphasizing ways to increase one's fiber intake, along with increased amounts of water, subjects were not only provided with positive behaviors to incorporate, but could avoid sole concentration on behaviors that are to be avoided. The greater the amount of fiber included in the diet, the lower the fat intake. The positive response shown to this information, particularly by subjects at more advanced stages of change appears to help them gain more information and facilitate identification of new approaches to reach their goals.

The flow of each session made certain differences clear. Sufficient time needs to be allowed in sessions for later stages of change due to the higher level of group interaction. Individuals in earlier stages of change need more demonstration style information and practical experiences incorporated into the sessions. It was also evident that actors and maintainers have the knowledge and experience to be a source of real help to subjects at earlier stages of dietary change. However, they may need some group orientation before this interaction takes place to ensure that they are not a source of discouragement as might occur if the methods used to assist others to change are harsh and controlling.

Conclusions

In this project experiment, a dietary intervention program was recommended to reduce breast cancer risk by working with middle to high income African American women on specific ways, primarily through food selection and preparation, to lower fat intake to a self-reported level of less than 25% of daily calorie intake. In focus groups comprised of similar stage of change subjects, the processes recommended and desired by the focus group participants proved to be intensive, requiring continuing multi-faceted support from the project facilitators. The Facilitator's Manual developed for the project will be modified at each year and stage of change based on the feedback available from subjects so as to achieve an appropriate mix of subject satisfaction and availability of human and material resources. A draft of the current manual including presentation guidelines for each stage of change session appears in the Appendix.

Table 1

**POSTERS AND BROCHURES USED FOR DIETARY INTERVENTION
SESSIONS**

Eat Foods with Fiber at Every Meal poster
NIH Publication

Eat Your Way to Good Health poster
NIH Publication

Eat Less Fat flyer/mailer
NIH Pub #P932F

Down Home Healthy flyer
NIH Pub #94-3408P

**Eat More Fruits & Vegetables
5 A Day for Better Health**
NIH Pub #92-3248

Action Guide for Healthy Eating
NIH Pub #95-3877

What's New About the New Food Label
NIH Pub #94-3648B

Table 2

Summary Chart of Focus Group Recommendations

TTM Stage	Interaction	Receptivity	Interests	Contact Needs	Contact Frequency
Pre-Contemplators	Heavy	Extremely open to change	Substitutions; End result; goal; taste; reminder info	Meetings; mailings; tele calls	Quarterly mtgs & mailings; monthly update tele calls
Contemplators	Moderate	Info well recvd	Health; share dishes; taste	Meetings; mailings; tele calls	Quarterly mtgs; routine mailings; routine tele call motivator
Preparers	Interactive	Info well recvd	Recipes; taste	Meetings; mailings; tele calls	Bi-weekly mtgs; monthly mailings & tele progress calls
Acters	Very interactive	Delighted	Convenience; share recipes; taste; gain more info	Meetings; mailings; tele calls	Monthly 1-hour mtgs; mailings on DI schedule; tele calls freq- quarterly
Maintainers	Extremely interactive	High	Recipes; Role models; health; good food; food preparation; substitutions	Meetings; mailings	Bi-monthly mtgs; mailings on DI schedule

DIFGSMC.DOC.P1

Table 3

Recommended Schedule For Dietary Intervention Sessions For Each Stage of Dietary Change

STAGES	'96 QUARTER	'97 1st Q	'97 2nd Q	'97 3rd Q
Precontemplators	OCT'96	JAN'97	APR'97	JUL'97
Contemplators	PC:tele	PC:tele	PC:tele	PC:tele
Preparers	C:mail/tele	C:mail/tele	C:mail/tele	C:mail/tele
Acters	P:mtgs:2/mail	P:mtgs:2/mail	P:mtgs:2/mail	P:mtgs:2/mail
Maintainers	A:mtg	A:mtg	A:mtg	A:mtg
	M:mtg	M:mtg	M:mtg	
Precontemplators	NOV'96	FEB'97	MAY'97	AUG'97
Contemplators	PC:mtg/mail/tele	PC:mtg/mail/tele	PC:mtg/mail/tele	PC:mtg/mail/tele
Preparers	C:mtg/mail/tele	C:mtg/mail/tele	C:mtg/mail/tele	C:mtg/mail/tele
Acters	P:mtgs:2/mail	P:mtgs:2/mail	P:mtgs:2/mail	P:mtgs:2/mail
Maintainers	A:mtg/tele	A:mtg/tele	A:mtg/tele	A:mtg/tele
	M:mail	M:mtg	M:mail	M:mtg
Precontemplators	DEC'96	MAR'97	JUN'97	SEP'97
Contemplators	PC:tele	PC:tele	PC:tele	PC:tele
Preparers	C:mail/tele	C:mail/tele	C:mail/tele	C:mail/tele
Acters	P:mtgs:2/mail	P:mtgs:2/mail	P:mtgs:2/mail	P:mtgs:2/mail
Maintainers	A:mtg	A:mtg	A:mtg	A:mtg
	M:mtg	M:mtg	M:mtg	

DIFGSCHQ.DOC

Table 4

Focus Group Responses to Dietary Intervention Materials

TTM Stage	Eat Foods with Fiber at Every Meal poster	Eat Your Way to Good Health poster	Eat Less Fat flyer/mailer	Down Home Healthy flyer	Eat More Fruits & Veggies-5 A Day for Better Health	Action Guide to Healthy Eating	What's New About the New Food Label	Additional Information	Summary	
Pre-Contemplators	Good for menu examples; bkfst NOT appealing; use to target profits	Appropriate	Appropriate	Appropriate; substitution list very popular	NA	NA	Not recommended; more receptive to basic fiber info	End result & ease of action effective for change	Group committed to change	Respond to increased info
Contemplators	Appropriate	Appropriate	Appropriate	Appropriate	NA	NA	Not as appropriate as other brochures	Group voluntarily committed to change	Info produced change commitment; knowing small steps impt.	
Preparers	Not attractive	Appealing meal, models & expressions	Appropriate	Valued recipes	Use for review	NA	Appealing, but more interested in foods that contain fiber	Committed to mail flyer immediately	Making habits permanent	Respond to info
Acters	Positive resp: good demo with high fiber; everyone can identify with people in pic	Positive resp: good food portion examples; plates not overloaded	Appropriate: shows current activities of this stage	Positive resp: substitution list highly valued	Positive resp: affirmed new eating habits; nutrition chart helpful	Positive resp: answers questions about fat	Appropriate	Aware of supports in environment	All plan to mail cookbook coupon same day as session	Taking action now; seeking more & related info
Maintainers	Recommended but not very appealing	Striking; recommended	Recommended	Recommended striking; very popular piece	Recommended	Recommended	Recommended			

NA = Not Administered

DIFGSMC.DOC, P2

APPENDIX

DRAFT

*Take Charge of Your Life
and Health*

DIETARY INTERVENTION PROJECT

FACILITATOR MANUAL

Developers

Jane Fort
Tonya Smith
Harlyn Jones
Jan Bigelow
LeMonica Lewis
Margaret K. Hargreaves

**NOTE: The information contained in this draft is
priviledged, preliminary, subject to change and may
not be disclosed or disseminated without the
permission of the Principal Investigator**

TABLE OF CONTENTS

I.	Overview of Need for Intervention.....	1
A.	Project Introduction.....	3
B.	Cancer Information.....	4
C.	Breast Cancer Prevention.....	5
D.	Fat/Fiber Dietary Principles.....	6
II.	Focusing on Behavior Change.....	7
A.	Overview.....	7
B.	Overview & Summary of Precontemplation Stage.....	8
C.	Overview & Summary of Contemplation Stage.....	9
D.	Overview & Summary of Preparation Stage.....	10
E.	Overview & Summary of Action Stage.....	11
F.	Overview & Summary of Maintenance Stage.....	12
III.	Guidelines for Change.....	13
A.	Precontemplation Stage.....	13
B.	Contemplation Stage.....	15
C.	Preparation Stage.....	17
D.	Action Stage.....	19
E.	Maintenance Stage.....	21

OVERVIEW OF NEED FOR INTERVENTION

I. PROJECT INTRODUCTION

The Dietary Intervention project is a part of the national effort to reduce breast cancer in African American women in this country. In 1996, approximately 184,000 women in the United States will be diagnosed with breast cancer. About 44,000 women will die from the disease. More than 80% of breast cancers are diagnosed in women with no family history of cancer. Breast cancer is the second leading cause of cancer death in African American women. Dietary fat is believed to cause breast cancer and other health problems. We would like to reduce the dietary fat intake in African American women by 25% in order to evaluate its effectiveness in breast cancer reduction. The Department of Defense has provided funding to the Meharry Medical College Department of Internal Medicine for the Community Coalition for Minority Health (CCMH) to develop a plan for assessing and reducing dietary fat intake in African American women.

Your help in this project assists in designing this plan. We are asking for your support in order to learn more about your eating styles. We need information from you, your family and friends to develop a clear understanding about African American dietary practices. You will be asked to attend discussion group sessions and to complete questionnaires for the project. All information is considered confidential and will be seen only by those employed on the project. Names will not be associated with the project data and/or results.

II. WHY IS CANCER A PROBLEM?

- o Cancer is the leading cause of death in the United States for people under 65 years of age; it is the second leading cause of death for all ages.
- o African Americans are diagnosed with cancer and die from it more often than any other group.
- o African American women are diagnosed with breast cancer before the age of 40.
- o Death rates for breast cancer in African American women are not decreasing.
- o Scientific evidence indicates that 35% of cancer deaths are related to diet.
- o Fat in the diet is related to breast cancer.
- o African American women tend to eat fatty foods.

III. BREAST CANCER PREVENTION

- o Every woman is at risk for breast cancer; African American women are at greater risk than other women.

- o One woman in every ten will develop breast cancer in her lifetime.

- o Every woman should check her breasts for changes each month.

- o Every woman should have a clinical breast exam every year.

- o African American women should have a mammogram in the twenties; starting at age 40, each should have a mammogram every one to two years.

- o Every woman should eat foods that are low in fat and high in fiber.

IV. EAT LESS FAT and MORE FIBER

- o You can reduce the fat in your diet through simple and easy changes in what you eat and how you prepare your food.
- o Select fresh fruits and vegetables for dessert and snacks.
- o Select whole grain breads and cereals for meals and snacks,
- o Bake, broil and steam food to avoid fats in frying.
- o Add flavor to dishes by using herbs, juices or lean meat rather than butter and oils.
- o Choose low-fat or no-fat products.
- o Eat fruits and vegetables with the edible skins: apples, potatoes, peaches
- o Cut off and discard extra fat on meats, including skin on poultry.
- o Use oil spray for cooking meat; pour off fat as meat cooks.
- o Reduce the portion of fatty foods served and consumed at meals.

FOCUSING ON BEHAVIOR CHANGE

II. Focusing on Behavior Change

Researchers S.R. Rossi and J.S. Rossi have modified the Prochaska Transtheoretical Model which integrates eleven behavioral strategies used by self-changers and/or health care professionals to change dietary behavior; their model describes issues and behaviors which describe the typical behavior of individuals at various stages in the decision-making process regarding personal behavior changes.

Prior to concerted effort for behavior change, individuals and health care professionals must determine the current stage of the individual and thereby determine what strategies, activities or approaches would be most useful to support the desired change from one stage to another. The theory refers to this process as a model and proposes five related, fluid and identifiable stages:

The first stage is called Precontemplation and refers to those individuals who do not plan to change the particular behavior in the near future, that is, do not intend to make any effort to change within the next six months.

The second stage refers to those individuals who have not yet begun to make necessary changes, but who are thinking about changing and plan to begin the necessary effort to change within the next six months. This stage is called the Contemplation Stage.

The third stage of the theoretical model is called Preparation and refers to those individuals who have not yet made any changes but have made the decision to begin the change process within the next 30 days.

The fourth stage refers to those individuals who recently began necessary changes, but have been in the change process less than six months. This stage is called the Action Stage.

The fifth stage of the theoretical model is called Maintenance and refers to those individuals who have been conducting necessary behavior changes and have been doing so for more than six months.

Because people have many different reasons for their individual behavior choices, the Dietary Intervention Project will use the Transtheoretical Model of Change briefly described here in order to support individuals in their effort to improve their dietary habits and eat less fat and more fiber.

PRECONTEMPLATION STAGE (PC)

People have many different reasons for eating the way they do. Whether or not you decide to cut down on fat depends on how important the pros (benefits) and cons (hassles) of cutting down on fat are to you. People who are not ready to consistently avoid eating less fat are in what we call the Precontemplation or PC Stage; they usually **underestimate** the pros of changing and **overestimate** the cons or hassles of changing.

If you are in the PC Stage, to change, you must start with thinking more about the pros of changing. To move from the PRECONTEMPLATION to the CONTEMPLATION (C) Stage, you must **increase your pros** for changing. We have discovered that this Principle is true for many other health habits, too. As your pro list grows, you make progress toward change.

People in the PC Stage often don't realize how their behaviors and their choices affect their health. People in this Stage often resist or avoid learning what could help them to make healthy changes. They may put up barriers against thinking of changing by not talking, reading, watching, or learning more about their behavior. For example, some people refuse to read any new information about foods and health. They miss opportunities to get to know themselves and their eating habits better. When you are open to more information, you are ready to move on to the next principle of success in change: **become informed**.

To make progress toward the next stage, PCs need to **learn more** about health and how some choices affect personal health. What we do every day, that is, our behaviors, can increase or decrease our chances of getting sick or dying prematurely.

The most preventable causes of chronic disease are smoking, a high fat diet, lack of exercise, obesity, sun exposure and alcohol abuse. Each of these causes reflects a behavior choice. Knowing this information can help you make healthier choices for yourself.

A summary chart of the change principles proposed to move from one stage to the next, Precontemplation to Contemplation, appears on the next page.

PRECONTEMPLATORS

DO NOT CONSISTENTLY AVOID EATING HIGH FAT FOODS
DO NOT INTEND TO IN THE NEXT 6 MONTHS

NOT READY

FOCUS ON PROS

BECOME INFORMED

SUBSTITUTE FOR FATS

REDUCE FAT

COOK LOW FAT

EAT MORE FRESH FOODS

CONTEMPLATION STAGE (C)

To make progress in the Contemplation Stage, **pros or benefits of changing have to outweigh the cons or hassles** of changing. Cs need to think of the cons of changing as temporary challenges rather than as permanent barriers. In order to make progress, the cons of change have to shrink only half as much as the pros of change need to grow; for every hassle to keep from changing, identify at least two benefits experienced as a result of changing.

To move from Contemplation to the Preparation Stage, Cs need to **allow themselves to feel "at risk" or afraid or uncertain**. Recognizing feelings helps motivate for change.

To make progress, Cs need to **become MORE informed and keep informed**. They must actively participate in the process: read, watch or listen, look for and experiment to discover the right answers. Change is an opportunity to explore new ways of eating by selecting and preparing foods in ways that provide less fat. Cs must also **reevaluate how they think and feel about themselves** as someone who eats high fat foods.

To progress to the Preparation Stage, Contemplators need to take some small steps towards eating less fat. **Small steps can lead to big gains** over time. They must take at least one small step toward eating less fat; remembering that a few small changes can make a difference.

A summary chart of the change principles proposed to move from one stage to the next, Contemplation to Preparation, appears on the next page.

CONTEMPLATORS

DO NOT CONSISTENTLY AVOID EATING HIGH FAT FOODS
BUT INTEND TO IN THE NEXT 6 MONTHS

GETTING READY

144

INCREASE PROS

BECOME MORE INFORMED

MAKE IT PERSONAL

CREATE A NEW YOU

TAKE ONE SMALL STEP

PREPARATION STAGE (P)

Preparation is the Stage in which Ps are ready to do something about changing soon, realizing that the benefits of changing are greater than the costs. To become a true Preparer, Ps need to use three of the most powerful Principles:

- 1. Keep creating a new image.**
- 2. Get support.**
- 3. Make a commitment.**

A summary chart of the change principles proposed to move from one stage to the next, Preparation to Action, appears on the next page.

PREPARERS

DO NOT CONSISTENTLY AVOID EATING HIGH FAT FOODS
BUT INTEND TO IN THE NEXT 30 DAYS

READY

RE-CREATE THE NEW YOU

GET SUPPORT

MAKE A COMMITMENT

GO PUBLIC

SELECT ONE OF 3 ACTIONS

SET THE DATE

ACTION STAGE (A)

In the Action Stage, A's are making significant and regular changes that are obvious to everyone - especially to themselves.

-
- A's are regularly using low fat or nonfat foods and eating more vegetables, fruits, cereals, breads, rice and pasta.
 - A's are eating lower fat foods at breakfast, lunch, dinner and for snacks.
 - A's choose lower fat foods when they eat away from home.

The temptation to go back to old habits is one of the most common experiences people have after making behavior changes. To move from the Action Stage to the Maintenance Stage, A's need to **substitute healthy alternatives** when tempted to slip back into old habits. A's must learn to:

1. **Substitute healthy thoughts for tempting ones.**
2. **Cope with stress.**
3. **Substitute healthy activities for old habits.**
4. **Plan ahead.**

Another way for A's to deal with tempting situations is to **take control or change the situations** and avoid those that tempt while finding new situations that support new behavior.

1. **Avoid situations, activities, and objects that are tempting.**
2. **Increase the environmental cues and reminders.**
3. **Make a "to do" list which includes new health behavior goals.**

To progress to lifelong health behavior change, A's need to **give themselves rewards and accept rewards from others**. And it is important for them to seek **more ways to keep informed and remain realistic** about the changes they have made.

A summary chart of the change principles proposed to move from one stage to the next, Action to Maintenance, appears on the next page.

ACTERS

CONSISTENTLY AVOID EATING HIGH FAT FOODS
AND HAVE BEEN FOR LESS THAN 6 MONTHS

TAKING EFFECTIVE ACTION

SUBSTITUTE

TAKE CONTROL
PLAN AHEAD

REWARD YOURSELF

KEEP INFORMED

MAINTENANCE STAGE (M)

After six months of effective action sticking with change, As will have moved into the Maintenance Stage where they won't have to work as hard as they did in the Action Stage. Temptations will be decreasing and confidence will be increasing. Ms have to work to prevent slips, but it is easier. Ms will have to **manage setbacks** to progress to lifelong maintenance. View setbacks, lapses, or relapses as **opportunities for learning** rather than reasons for feeling guilty, embarrassed, or demoralized about their ability to change.

Ms must also **continue to use substitutes and take control**. To progress to full freedom from former habits Ms need to continue to **deal with occasional urges** to relapse; they must learn to control their environment so it supports their healthier lifestyle.

A summary chart of the above information appears on the next page.

MAINTAINERS

**CONSISTENTLY AVOID EATING HIGH FAT FOODS
AND HAVE BEEN FOR MORE THAN 6 MONTHS**

STICKING WITH IT

MANAGE SETBACKS

HANG IN THERE

GUIDELINES FOR CHANGE

V. Dietary Intervention for Precontemplators (PCs)

TTM Stages for PCs:

Consciousness Raising (CR)
Dramatic Relief (DR)
Self-Reevaluation (SR)
Environmental Reevaluation (ER)

Processes with PCs:

ADDRESSING THE STAGE CHARACTERISTICS

ADDRESSING WHAT WE KNOW ABOUT THE STAGE OF CHANGE

Not ready/cannot/unwilling to change
Lack awareness of problem
In denial about problem
Costs more important than benefits
Engage in dialog about reasons for unreadiness
Present "role models", examples of strategies
Present current stats about cancer, breast cancer,
diet, and African Americans

Tried and failed
Demoralized
High temptation to continue behavior
Low confidence in ability to change
Engage in dialog about experiences
Present new and fresh info and ideas about issue
Indicate supports available
Present "role models", examples of strategies

CLIENT TASKS IN THIS STAGE OF CHANGE

Think about the problem
Recognize problem as major health problem
Personalize the problem
Engage in dialog about personal experiences
Provide stats and role model info
Provide info re long-term consequences of behavior

GUIDELINES TO FACILITATE CHANGE: Be non-judgemental!!

Recruitment
Indicate interest in those not involved
Increase awareness of the problem
give info and feedback
Resistance
Provide list of pros and cons to change
Deal with denial and defensiveness
be tough without preaching
Retention: Use innovative, exciting interventions

Pcs cont'd

TTM PROCESSES FOR PCS:

Consciousness Raising:

provide info:

Spread the Word about Cancer: Guide...

Dramatic Relief:

create emotional motivator

survivor statement (DAI clip)

Self-Reevaluation:

encourage reappraisal, reassessment

Environmental Reevaluation:

emphasize impact on others (influence on kids)

inquire about/discuss Ss role in family meals

Dietary Intervention Focus Group Presentation Guidelines Precontemplators (PC's)

Welcome and Introductions

- Presenter extends a general welcome to the group
- Presenter starts the round robin (everyone provides their name and encouraged to share one thing about themselves regarding food or nutrition).
- Group confidentiality pledge. Presenter requests that all comments and information shared during the focus group should be kept confidential to the group.

Meeting Overview

- Presenters reconfirms stage; re-introduce project from Spring '96.
- Presenter acknowledges the difficulty in making the decision to select a low fat diet
- Presenter asks the group to share their cons or dietary barriers
- Presenter explains the relationship between high fat diets, certain chronic diseases and African American women.
 - Presenter asks clients to provide suggestions of traditional African American meals.
 - Dramatic relief - photograph of advanced breast cancer.
- Presenter draws group's attention to the "Eat Your Way to Good Health" poster and projects the same image on the overhead screen.
 - Presenters asks the group to describe the low fat/high fiber aspects of the meal (the presenter chimes in as needed to ensure that all aspects of the meal are covered).
 - Presenter asks the group to share ways they are incorporating these aspects into their eating and food preparation habits
- Presenter distributes "Down Home Healthy" flyer. Point out recipes; identify as recommended by African American chefs for African American palates
 - Presenter highlights food substitutions listed on the back of the flyer.
 - Presenter highlights recipes and identify aspects of the menus which are low fat and healthier.

Dietary Intervention Focus Group Presentation Guidelines Precontemplators (PC's)

- Presenter draws the groups attention to the "Eat Foods with Fiber at Every Meal" poster.
 - Presenter ask the group if any of the menus look like meals they would consider trying.
 - Presenter asks clients to comment on the menu suggestions.
- Presenter shares the low fat aspects of their lunch and ask for their response to it's taste.
- Presenter distributes NCI "Eat Less Fat" mailer/flyer, asking participants to identify low fat/high fiber elements of each menu.
 - Presents asks clients to share perspectives on the poster's recommendations.
 - Presenters asks clients to share their suggestions on low fat substitutions/alternatives.
- Presenter introduces dietician to cover food label information
 - Dietician distributes "What's New About the New Food Label" leaflet
 - Dietician explains how to properly read and apply nutritional information on food labels.
 - Dietician places emphasis on including the appropriate daily amounts of dietary fiber by highlighting cereal brands and their fiber content.
 - Presenter asks the group to consider making a commitment to start a low fat/high fiber diet in the next six months.
 - Presenter reminds the group of readily available information and the support others in the environment can offer.

Presenter asks participants who are willing to commit to a low fat diet to sign the "Celebration of Change" poster.

Dietary Intervention Focus Group Presentation Guidelines Precontemplators (PC's)

□ Presentation Feedback

- Presenter gathers recommendations regarding materials presented
 - "Eat Your Way to Good Health" Poster
 - "Down Home Healthy" Flyer
 - "Eat Foods with Fiber Every Day"
 - "Eat Less Fat"
- Dissemination /follow up format
 - By telephone, group meetings, individual meetings, mailing correspondence
 - Frequency contacts
 - Influence of presentation on client

□ Closure

- Request specific commitment to begin low fat eating in next six months
- Presenter encourages the group to post or hang materials in the kitchen.
- Presenter shares with the group to expect a follow up call in two weeks to see if they have any additional suggestions to improve the study.
- Presenter gathers signatures and distributes a \$5.00 token for focus group participation.
- Presenter thanks the group for their participation in the focus group.

VI. Dietary Intervention for Contemplators (Cs)

TTM Stages for Cs:

Consciousness Raising (CR)
Self-Reevaluation (SR)
Self-Liberation (SeL)
Social Liberation (SoL)
Helping Relationships (HR)

Processes with Cs:

ADDRESSING THE STAGE CHARACTERISTICS

ADDRESSING WHAT WE KNOW ABOUT THE STAGE OF CHANGE

Thinking about change

Ambivalent

Aware should change but don't want to

Costs (cons) of change are greater & more salient

Benefits (pros) will increase

Decisional Balance (roughly equal pros and cons)

Engage in dialog about reasons for ambivalence

Present "role models", examples of strategies

Present current stats about cancer, breast cancer,
diet, African Americans and benefits of
change

Situational temptation remains high

Confidence in ability to change remains low

Engage in dialog about experiences

Present new and fresh info and ideas about issue

Indicate supports available

Present "role models"

Present strategies for controlling situations

CLIENT TASKS IN THIS STAGE OF CHANGE

Turn thought into behavior

Make decision to change

Engage in dialog about experiences with change

Present strategies for "getting off the fence"

GUIDELINES TO FACILITATE CHANGE

Actively engage Cs in generating pros and cons

Acknowledge difficulties inherent in change

Provide info on the benefits of change

Get to make commitment to first step

Establish time-line

Create or identify support mechanisms/systems

TTM PROCESSES FOR Cs:

Consciousness Raising:

provide info:

Spread the Word about Cancer: Guide...

Self-Reevaluation:

encourage reappraisal, reassessment

Cs cont'd

Self-Liberation:

- encourage making change by "can-do" belief
- utilize client's will power, commitment, choices
- show alternative choices available via change
 - create or identify support mechanisms/systems
- encourage making commitment
 - establish time-line

Social Liberation:

- help to notice supports to change (menu choices)
 - create or identify support mechanisms/systems

Helping Relationships:

- encourage to seek out and accept help when offered
 - create or identify support mechanisms/systems

Dietary Intervention Focus Group Presentation Guidelines Contemplators (C's)

□ Welcome and Introductions

- Presenter extends a general welcome to the group
- Presenter starts the round robin (everyone provides their name and encouraged to share one thing about themselves regarding food or nutrition).
- Group confidentiality pledge. Presenter request that all comments and information shared during the focus group should be kept confidential to the group.

□ Meeting Overview

- Presenters acknowledges difficulty regarding making dietary changes.
- Presenter asks the group to share identify cons or barriers regarding adopting a low fat diet.
- Presenter shares the importance of proper nutrition to promote general good health and wellness.
- Presenter explains the relationship between high fat diets, certain chronic diseases and African American women.
 - Presenter asks clients to provide suggestions of traditional African American meals.
 - Dramatic relief - photograph of advanced colon or breast cancer.
- Presenter Acknowledges difficulty regarding making dietary changes
 - Presenter provides personal testimony including personal cons and encourages the group to share a few of their barriers to be posted on the flip chart
- Presenter draws group's attention to the "Eat Your Way to Good Health" poster and projects the same image on the overhead screen.
 - Presenters asks the group to describe the low fat/high fiber aspects of the meal (the presenter chimes in as needed to ensure that all aspects of the meal are covered
 - Presenter ask the group to share ways they could incorporate these aspects into their eating and food preparation habits
- Presenter distributes "Down Home Healthy" flyer. Point out recipes; identify as recommended by African American chefs for African American palates

Dietary Intervention Focus Group Presentation Guidelines Contemplators (C's)

- Presenter highlights food substitutions listed on the back of the flyer.
- Presenter draws the groups attention to the "Eat Foods with Fiber at Every Meal" poster.
 - Presenter asks the clients to volunteer suggestion simple ways to incorporate dietary fiber into each meal.
 - Presenter asks clients to comment on the menu suggestions.
- Presenter shares a variety of environmental supports at local grocery/supermarkets, restaurants, bookstores, etc which encourage low fat food choices.
 - 5 A Day plastic produce bags
 - 5 A Day store announcements
 - Food packaging and labeling
 - Restuarant menu ques
- Presenter introduces dietician to cover food label information
 - Dietician distributes "What's New About the New Food Label" leaflet
 - Dietician explains how to properly read and apply nutritional information on food labels.
 - Dietician places emphasis on including the appropriate daily amounts of dietary fiber by highlighting cereal brands and their fiber content.
- Presenter distributes NCI "Eat Less Fat" mailer/flyer, asking participants to identify low fat/high fiber elements of each menu.
 - Presents asks clients to share perspectives on the poster's recommendations.
 - Presenters asks clients to share their suggestions on low fat substitutions/alternatives.
- Presenter asks the group to consider making a commitment to begin low fat/high fiber eating habits starting during the new fall semester and into the New Year.
 - Presenter reminds the group of readily available information and the support others in the environment can offer.
 - Presenter asks participants who are willing to commit to a low fat diet to sign the "Celebration of Change" poster.

Dietary Intervention Focus Group Presentation Guidelines Contemplators (C's)

Presentation Feedback

- Presenter gathers recommendations regarding materials presented
 - "Eat Your Way to Good Health" Poster
 - "Down Home Healthy" Flyer
 - "Eat Foods with Fiber at Every meal" Poster
 - "Eat Less Fat"
- Dissemination /follow up format
 - By telephone, group meetings, individual meetings, mailing correspondence
 - Frequency contacts
 - Influence of presentation on client

Closure

- Request specific commitment to begin low fat eating in next six months
- Presenter encourages the group to post or hang materials in the kitchen.
- Presenter shares with the group to expect a follow up call in two weeks to see if they have any additional suggestions to improve the study.
- Presenter gathers signatures and distributes a \$5.00 token for focus group participation.
- Presenter thanks the group for their participation in the focus group.

VII. Dietary Intervention for Preparers (Ps)

TTM Stages for Ps:

Consciousness Raising (CR)
Self-Reevaluation (SR)
Self-Liberation (SeL)
Social Liberation (SoL)
Helping Relationships (HR)
Counter-Conditioning (CC)
Stimulus Control (SC)

Processes with Ps:

ADDRESSING THE STAGE CHARACTERISTICS

ADDRESSING WHAT WE KNOW ABOUT THE STAGE OF CHANGE

Ready, and intend to change
Have a vague plan for change
Committed to change
Will attempt to change and may fail
Engage in lots of experimentation
Benefits of change outweigh costs
Will engage in change behavior
Clarify "hang-ups"
High temptation to continue behavior
Low confidence in ability to change
Provide examples, "role models"

CLIENT TASKS IN THIS STAGE OF CHANGE

Try out different change strategies
Recognize what works and what doesn't
Learn from personal mistakes

GUIDELINES TO FACILITATE CHANGE

Assist with ideas, specific recs, choices
Provide change models
Provide detailed plan with doable, small steps
Provide schedule for feedback

TTM PROCESSES FOR Ps:

Consciousness Raising:
provide info

Self-Reevaluation:
encourage reappraisal, reassessment
help to recognize own personal triggers

Self-Liberation:
encourage making change by having a "can-do" style
encourage making commitment; provide coping skills
utilize client's will power, commitment, choices
show alternative choices available in change
increase client's confidence to resist temptation

Social Liberation:
help to notice supports to change (menu choices)

Ps cont'd

Helping Relationships:

encourage to seek out and accept help when offered

Counter-Conditioning:

help identify possible substitutions for old habit

Stimulus Control:

help reduce or avoid old cues

Dietary Intervention Focus Group Presentation Guidelines Preparers (Ps)

Welcome and Introductions

- Presenter extends a general welcome to the group
- Presenter starts the round robin (everyone provides their name and encouraged to share one thing about themselves regarding food or nutrition).
- Group confidentiality pledge. Presenter request that all comments and information shared during the focus group should be kept confidential to the group.

Meeting Overview

- Presenter reconfirms stage; re-introduce project from Spring '96.
- Presenter Acknowledges difficulty regarding making dietary changes
 - Presenter encourages the group to identify cons or barriers regarding adopting a low fat diet
 - Presenter shares the importance of proper nutrition to promote general good health and wellness
- Presenter explains the relationship between high fat diets, certain chronic diseases and African American women.
 - Presenter asks clients to provide suggestions of traditional African American meals.
 - Dramatic relief - photograph of advanced breast cancer.
 - Presenter draws group's attention to the "Eat Your Way to Good Health" poster.
 - Presenters asks the group to describe the low fat/high fiber aspects of the meal, with the presenter chiming in as needed to ensure that all aspects of the meal is covered.
 - Presenter ask the group to identify low fat/high fiber aspects of their lunch.

Dietary Intervention Focus Group Presentation Guidelines Preparers (Ps)

- Presenter distributes "Down Home Healthy" flyer.
 - Points out recipes; identify as recommended by African American chefs for African American palates
 - Points out low-fat food substitutions on back
 - Ask the clients to share their own experiences on hearing about and/or trying substitutions
- Presenter draws the groups attention to the "Eat Foods with Fiber at Every Meal" poster.
 - Presenter points out high fiber menus
 - Presenter encourages clients to share their reactions to the menu suggestions
 - Presenter asks clients if they can identify any of the menus which they would try within the next 30 days
- Presenter shares a variety of environmental supports at local grocery/supermarkets, restaurants, bookstores, etc which encourage low fat food choices.
 - 5 A Day plastic produce bags
 - 5 A Day store announcements
 - Food packaging and labeling - Presenter introduces dietician who explains how to read food labels
 - Restuarant menu ques
- Presenter introduces dietician to cover food label information
 - Dietician distributes "What's New About the New Food Label" leaflet
 - Dietician explains how to properly read and apply nutritional information on food labels.
 - Dietician places emphasis on including the appropriate daily amounts of dietary fiber by highlighting cereal brands and their fiber content.
- Presenter distributes NCI "Eat Less Fat" mailer/flyer, asking participants to identify low fat/high fiber elements of each menu.
 - Presenter asks clients to identify which procedures they could attempt within next 30 days
 - Presenters asks clients to share their suggestions on low fat substitutions/alternatives.

Dietary Intervention Focus Group Presentation Guidelines

Preparers (Ps)

- Presenter asks the group to consider making a commitment to begin low fat/high fiber eating habits starting in within 30 days
 - Presenter reminds the group of readily available information and the support others in the environment can offer.
 - Presenter encourages clients to call on supporters during change process
- Presenter points out "Down Home Healthy" flyer mail-in card to a complimentary low fat/high fiber cookbook.
 - Presenter request that clients complete the card and mail it on the way back to the office via MMC mailroom.
 - Clients committing to making changes are asked to sign the "Celebration of Change" poster.

Presentation Feedback

- Presenter gathers recommendations regarding materials presented
 - "Eat Your Way to Good Health" Poster
 - "Down Home Healthy" Flyer
 - "Eat Foods with Fiber at Every meal" Poster
 - "Eat Less Fat"
- Dissemination /follow up format
 - By telephone, group meetings, individual meetings, mailing correspondence
 - Frequency contacts
 - Influence of presentation on client

Closure

- Request specific commitment to begin low fat eating in 30 days
- Presenter encourages the group to post or hang materials in the kitchen.
- Presenter shares with the group to expect a follow up call in two weeks to see if they have any additional suggestions to improve the study.
- Presenter gathers signatures and distributes a \$5.00 token for focus group participation.
- Presenter thanks the group for their participation in the focus group.

VIII. Dietary Intervention for Acters (A's)

TTM Processes for A's:

Consciousness Raising (CR)
Self-Liberation (SeL)
Environmental Reevaluation (ER)
Helping Relationships (HR)
Counter-Conditioning (CC)
Stimulus Control (SC)
Reinforcement Management (RM)
Interpersonal Systems Control (ISC)

Processes with A's:

ADDRESSING THE STAGE CHARACTERISTICS

ADDRESSING WHAT WE KNOW ABOUT THE STAGE OF CHANGE

Have a plan for change
Implemented plan to change
Relapse and fluctuate although plan generally works

Benefits of change decrease but remain high
Costs of change decrease
Low temptation to continue old behavior
High confidence in ability to change
Difficulty managing change
 especially in positive social situations
 in difficult situations

CLIENT TASKS IN THIS STAGE OF CHANGE

Hang in with change strategies for benefits
Manage relapses

GUIDELINES TO FACILITATE CHANGE

Provide change strategy recs
Support through change
Help prevent relapse
Help recover from relapse
Recycle quickly through earlier stages

TTM PROCESSES FOR A's:

Consciousness Raising:
 provide info

Self-Liberation:
 provide coping skills vs positive social
 provide coping skills vs difficult situations
 utilize client's will power, commitment, choices
 increase client's confidence to resist temptation

Environmental Reevaluation:
 emphasize impact on others (influence on kids)

Helping Relationships:
 encourage to seek out and accept help when offered

A's cont'd

Counter-Conditioning:

- help identify possible substitutions for old habit
- provide alternative menus

Stimulus Control:

- help reduce or avoid old cues
- suggest alternative places, activities

Reinforcement Management: reward system

- recommend low-fat rewards
- recommend rewards unrelated to food

Interpersonal Systems Control:

- support-seeking
- facilitate networks
- temptation avoidance
- recommend personal strategies

Dietary Intervention Focus Group Presentation Guidelines Acters (A's)

□ Welcome and Introductions

- Presenter extends a general welcome to the group
- Presenter starts the round robin (everyone provides their name and encouraged to share one thing about themselves regarding food or nutrition).
- Group confidentiality pledge. Presenter request that all comments and information shared during the focus group should be kept confidential to the group.

□ Meeting Overview

- Presenter reconfirms stage; re introduce project from Spring '96.
- Presenters acknowledges difficulty regarding making dietary changes and congratulates group on having begun to change eating habits.
 - Presenter provides personal testimony including personal cons and encourages the group to share a few of their barriers to be posted on the flip chart
 - Presenter encourages group to share challenges experienced during the last few months in changing eating habits; list on board.
- Presenter explains the relationship between high fat diets, certain chronic diseases and African American women.
 - Presenter asks clients to provide suggestions of traditional African American meals.
 - Dramatic relief - photograph of advanced colon or breast cancer.
- Presenter draws group's attention to the "Eat Your Way to Good Health" poster and projects the same image on the overhead screen.
 - Presenters asks the group to describe the low fat/high fiber aspects of the meal (the presenter chimes in as needed to ensure that all aspects of the meal is covered).
 - Presenter ask the group to share ways they could incorporate these aspects into their eating and food preparation habits
- Presenter distributes "Down Home Healthy" flyer. Point out recipes; identify as recommended by African American chefs for African American palates
 - Presenter highlights food substitutions listed on the back of the flyer.

Dietary Intervention Focus Group Presentation Guidelines

Acters (A's)

- Presenter highlights recipes and asks group to identify aspects of the information that are or plan to incorporate in their food preparation and selection plans.
- Presenter distributes "Action Guide for Healthy Eating"
 - Presenter highlights the nutritional charts and information regarding fruits, vegetables, grains and breads etc.
- Presenter encourages the group to review the piece more thoroughly later.
- Presenter draws the groups attention to the "Eat Foods with Fiber at Every Meal" poster.
 - Presenter asks the clients to volunteer suggestion simple ways to incorporate dietary fiber into each meal.
 - Presenter asks clients to comment on the menu suggestions.
- Presenter asks group to identify the low fat aspects of their lunch; presenter to add any aspects the group does not identify.
- Presenter shares a variety of environmental supports at local grocery/supermarkets, restaurants, bookstores, etc which encourage low fat food choices.
 - 5 A Day plastic produce bags
 - 5 A Day store announcements
 - Food packaging and labeling
 - Restuarant menu ques
- Presenter introduces dietician to cover food label information
 - Dietician distributes "What's New About the New Food Label" leaflet
 - Dietician explains how to properly read and apply nutritional information on food labels.
 - Dietician places emphasis on including the appropriate daily amounts of dietary fiber by highlighting cereal brands and their fiber content.
- Presenter distributes NCI "Eat Less Fat" mailer/flyer, asking participants to identify low fat/high fiber elements of each menu.
 - Presents asks clients to share perspectives on the poster's recommendations.

Dietary Intervention Focus Group Presentation Guidelines Acters (A's)

- Presenters asks clients to share their suggestions on low fat substitutions/alternatives.
- Presenter asks the group to consider making a commitment to maintain their low fat/high fiber eating habits over the next six months.
 - Presenter reminds the group of readily available information and the support others in the environment can offer.

Presentation Feedback

- Presenter gathers recommendations regarding materials presented
 - "Eat Your Way to Good Health" Poster
 - "Down Home Healthy" Flyer
 - "Eat Foods with Fiber at Every meal" Poster
 - "Eat Less Fat"
 - "Eat More Foods with Fruit and Fiber"
 - "Action Guide for Healthy Eating"
- Dissemination /follow up format
 - By telephone, group meetings, individual meetings, mailing correspondence
 - Frequency contacts
 - Influence of presentation on client

Closure

- Request specific commitment to begin low fat eating in next six months
- Presenter encourages the group to post or hang materials in the kitchen.
- Presenter shares with the group to expect a follow up call in two weeks to see if they have any additional suggestions to improve the study.
- Presenter gathers signatures and distributes a \$5.00 token for focus group participation.
- Presenter thanks the group for their participation in the focus group.

IX. Dietary Intervention for Maintainers (Ms)

TTM Stages for Ms:

Consciousness Raising (CR)
Self-Liberation (SeL)
Environmental Reevaluation (ER)
Helping Relationships (HR)
Counter-Conditioning (CC)
Stimulus Control (SC)

Processes with Ms:

ADDRESSING THE STAGE CHARACTERISTICS

ADDRESSING WHAT WE KNOW ABOUT THE STAGE OF CHANGE

Continue change processes
Relapse less likely
Clients remain vigilant vs relapse
Benefits of change decrease but remain high
Costs of change decrease
Low temptation to continue old behavior
High confidence in ability to change

CLIENT TASKS IN THIS STAGE OF CHANGE

Sustain change as life-long habit
Resist pull of stress into old habits

GUIDELINES TO FACILITATE CHANGE

Help prevent relapse when risk is perceived
Help recover from relapse and recycle quickly
Learn relapse triggers: events, timing, demogs
Learn best strategies for life-long change

TTM PROCESSES FOR Ms:

Consciousness Raising:
provide info

Self-Liberation:
provide coping skills
vs stressful situations
utilize client's will power, commitment, choices
increase client's confidence to resist temptation

Environmental Reevaluation:
emphasize impact on others (influence on kids)

Helping Relationships:
encourage to seek out and accept help when offered

Counter-Conditioning:
help identify possible substitutions for old habit

Stimulus Control:
help reduce or avoid old cues
provide broader diet choices for "healthy eating"
help increase fiber, fruits, vegs in daily diet

Dietary Intervention Focus Group Presentation Guidelines Maintainers (M's)

□ Welcome and Introductions

- Presenter extends a general welcome to the group
- Presenter starts the round robin (everyone provides their name and encouraged to share one thing about themselves regarding food or nutrition).
- Group confidentiality pledge. Presenter requests that all comments and information shared during the focus group should be kept confidential to the group.

□ Meeting Overview

- Presenter reconfirms stage; re introduce from Spring '96.
- Presenter explains the relationship between high fat diets, certain chronic diseases and African American women.
 - Presenter asks clients to provide suggestions of traditional African American meals.
 - Dramatic relief - photograph of advanced breast cancer.
- Presenter draws group's attention to the "Eat Your Way to Good Health" poster and projects the same image on the overhead screen.
 - Presenters asks the group to describe the low fat/high fiber aspects of the meal (the presenter chimes in as needed to ensure that all aspects of the meal are covered
 - Presenter ask the group to share ways they are incorporating these aspects into their eating and food preparation habits
- Presenter distributes "Down Home Healthy" flyer. Point out recipes; identify as recommended by African American chefs for African American palates
 - Presenter highlights food substitutions listed on the back of the flyer.
 - Presenter highlights recipes and asks group to identify aspects of the information that are or plan to incorporate in their food preparation and selection plans.
 - Presenter encourages group to mail their cookbook request cards immediately from work.

Dietary Intervention Focus Group Presentation Guidelines Maintainers (M's)

- Presenter distributes "Action Guide for Healthy Eating"
 - Presenter highlights the nutritional charts and information regarding fruits, vegetables, grains and breads etc.
 - Presenter encourages the group to review the piece more thoroughly later.
- Presenter draws the groups attention to the "Eat Foods with Fiber at Every Meal" poster.
 - Presenter asks the clients to volunteer suggestion simple ways to incorporate dietary fiber into each meal.
 - Presenter asks clients to comment on the menu suggestions.
- Presenter asks group to identify the low fat aspects of their lunch; presenter to add any aspects the group does not identify.
- Presenter highlights the "Eat More Fruits & Vegetables" brochure
 - Presenter draws attention to the nutritional charts and snack suggestions
- Presenter shares a variety of environmental supports at local grocery/supermarkets, restaurants, bookstores, etc which encourage low fat food choices.
 - 5 A Day plastic produce bags
 - 5 A Day store announcements
 - Food packaging and labeling
 - Restuarant menu ques
- Presenter distributes NCI "Eat Less Fat" mailer/flyer, asking participants to identify low fat/high fiber elements of each menu.
 - Presents asks clients to share perspectives on the poster's recommendations.
 - Presenters asks clients to share their suggestions on low fat substitutions/alternatives.

Dietary Intervention Focus Group Presentation Guidelines Maintainers (M's)

- Presenter introduces dietician to cover food label information
 - Dietician distributes "What's New About the New Food Label" leaflet
 - Dietician explains how to properly read and apply nutritional information on food labels.
 - Dietician places emphasis on including the appropriate daily amounts of dietary fiber by highlighting cereal brands and their fiber content.
 - Presenter asks the group to consider making a commitment to maintain their low fat/high fiber eating habits and to serve as role models for others who are attempting to change their dietary habits also.
 - Presenter reminds the group of readily available information and the support others in the environment can offer.
 - Presenter asks participants who are willing to commit to a low fat diet to sign the "Celebration of Change" poster.

Presentation Feedback

- Presenter gathers recommendations regarding materials presented
 - "Eat Your Way to Good Health" Poster
 - "Down Home Healthy" Flyer
 - "Eat Foods with Fiber at Every meal" Poster
 - "Eat More Fruits and Vegetables"
 - "Eat Less Fat"
 - "Action Guide for Healthy Eating"
- Dissemination /follow up format
 - By telephone, group meetings, individual meetings, mailing correspondence
 - Frequency contacts
 - Influence of presentation on client

Dietary Intervention Focus Group Presentation Guidelines Maintainers (M's)

▣ Closure

- Request specific commitment to begin low fat eating in next six months
- Presenter encourages the group to post or hang materials in the kitchen.
- Presenter shares with the group to expect a follow up call in two weeks to see if they have any additional suggestions to improve the study.
- Presenter gathers signatures and distributes a \$5.00 token for focus group participation.
- Presenter thanks the group for their participation in the focus group.

CONCLUSIONS

This second annual report presents four tools that will be important in the development, implementation, and evaluation of a culturally-sensitive intervention to lower dietary fat intake the diets of African American Women in Nashville, Tennessee, and to lower breast cancer risk in this population. These tools include:

- 1) a validated questionnaire based on the principles of the Transtheoretical Behavior Change Model that will determined an individual's stage of change characteristics;
- 2) an Eating Styles Questionnaire designed to pin-point specific foods that are preferred by individual attempting to select a low fat diet;
- 3) an Eating Behavior Patterns Questionnaire designed to understand the behaviors that prompt the selection of food components or nutrients associated with breast cancer risk; and
- 4) a Dietary Intervention Manual based on the principles of the Transtheoretical Model of Behavior Change that will assist facilitators in guiding the individual's change process.

The Eating Styles and Behavior Patterns Questionnaires were developed in Year 2 because of an administrative supplement to the primary grant. The simultaneous use of these tools for the Demonstration Phase of the project is expected to improve individual behavior outcomes.

Project Bibliography

A. Abstracts

1. Hargreaves, Margaret K. Reaching black women for a dietary intervention to reduce breast cancer risk. Sixth Annual Drew-Meharry-Morehouse Consortium Cancer Center Symposium, Nashville, TN, March 1995.
2. Hargreaves, Margaret K. Initiating dietary change in black women. Seventh Annual Drew-Meharry-Morehouse Consortium Cancer Center Symposium, Atlanta, GA, March 1996.
3. Three abstracts are being prepared for submission to the Society of Behavioral Medicine, held Spring, 1997.

B. Publications

1. Hargreaves, Margaret K., Schlundt, D. and Buchowski, M. Stages of change and the intake of dietary fat in African-American Women: Exploring the discrepancy between self-perception and behavior. In preparation.
2. Schlundt, D., Hargreaves, Margaret K., Buchowski, M. and Bigelow, J. Development and evaluation of an Eating Behavior Patterns Questionnaire. In preparation.

Personnel Receiving Pay

1. Margaret K. Hargreaves
2. Jane Fort
3. Tonya Smith
4. Jan Bigelow
5. Deborah Sparks
6. Maciej Buchowski
7. David Schlundt
8. Joseph Rossi
9. Susan Rossi
10. Harlyn Jones
11. Nasar Ahmed