

**VOLUME II
FLYING QUALITIES FLIGHT TEST**

**CHAPTER 11
ENGINE-OUT THEORY**

DISTRIBUTION STATEMENT A
Approved for public release
Distribution Unlimited

19970117 038

AUGUST 1992

**USAF TEST PILOT SCHOOL
EDWARDS AIR FORCE BASE, CALIFORNIA**

DTIC QUALITY INSPECTED 1

TABLE OF CONTENTS

11.1 INTRODUCTION	1
11.2 PERFORMANCE	1
11.2.1 The Performance Problem	1
11.2.2 Takeoff Performance	1
11.3 THE CONTROL PROBLEM	6
11.3.1 Steady State Equations of Motion	7
11.3.2 Effects of Bank Angle on Equilibrium	9
11.3.3 Air Minimum Control Speed (V_{mca})	14
11.3.4 Dynamic Engine Failure	18
11.3.5 Ground Minimum Control Speed (V_{mcg})	21
11.4 ENGINE OUT MILITARY STANDARDS	21
11.5 ENGINE OUT FLIGHT TESTING	22
11.5.1 In-flight Performance	22
11.5.2 Stall Evaluation	22
11.5.3 Landing Performance	23
11.5.4 Air Minimum Control Speed	23
11.5.5 Ground Minimum Control Speed	25
11.6 ENGINE OUT DATA ANALYSIS	26
11.6.1 Thrust Moment Analysis	26
11.6.2 Irreversible Control System	29
11.6.3 Reversible Control Systems	32
11.6.4 Secondary Method of Data Analysis	35
11.6.5 Lateral Control Data Analysis	37
11.7 APPLICATION OF THE THRUST MOMENT COEFFICIENT TECHNIQUE	40
11.7.1 IRREVERSIBLE CONTROL SYSTEM	40

11.8 DEFINITIONS	48
BIBLIOGRAPHY	51

11.1 INTRODUCTION

This chapter examines the problems associated with an engine failure and how engine out flight testing is accomplished. The discussion will begin with performance issues, how engine loss affects the takeoff and initial climb segments. Next, the equations of motion are introduced, modified for an engine failure. They are used to show how minimum control speeds are determined by design. Finally, flight test techniques are introduced for the evaluation of engine out flying characteristics of multiengine aircraft.

11.2 PERFORMANCE

11.2.1 The Performance Problem

Reduced climb performance, service ceiling, and range capability accompany an engine failure as a natural consequence of decreased thrust and increased drag. But the effect of an engine failure on takeoff performance is a more complex subject. Basically, the requirement is for the aircraft to attain a takeoff velocity at a given lift coefficient. At any point during the takeoff roll the pilot needs a variety of speeds on which to base a decision to abort or continue. These definitions vary considerably between the military and civil aircraft. The military usually receives its performance specifications from the Mission Needs Statement (MNS) written by the Major Air Command. MIL-C-005011B provides definitions and guidance for the preparation of performance charts. The civilians rely on Federal Aviation Regulations (FAR) Part 25 for guidance on takeoff performance.

11.2.2 Takeoff Performance

At every instant throughout the takeoff roll, the pilot must have an acceptable course of action available in the event of engine failure. During the first part of the takeoff roll, this action will be to abort the takeoff. Beyond a certain point the action will be to continue the takeoff with the engine failed. The dividing point between these courses of action is a function of aircraft performance and control.

11.2.2.1 Refusal Speed

Consider an aircraft in a particular configuration and gross weight. For any given runway length there is a maximum speed to which it can accelerate on all engines, experience a critical engine failure, and then complete a maximum effort stop at the far end of the runway. This speed, the refusal speed, (V_R), is relatively high for long runways and relatively low for short ones (see Figure 11.1). Stopping technique and devices to be used must be specified. This speed could also be maximum braking speed (V_{MB}) depending on how the speeds are designed. However, V_R must never exceed V_{MB} in order to avoid hazardous conditions.

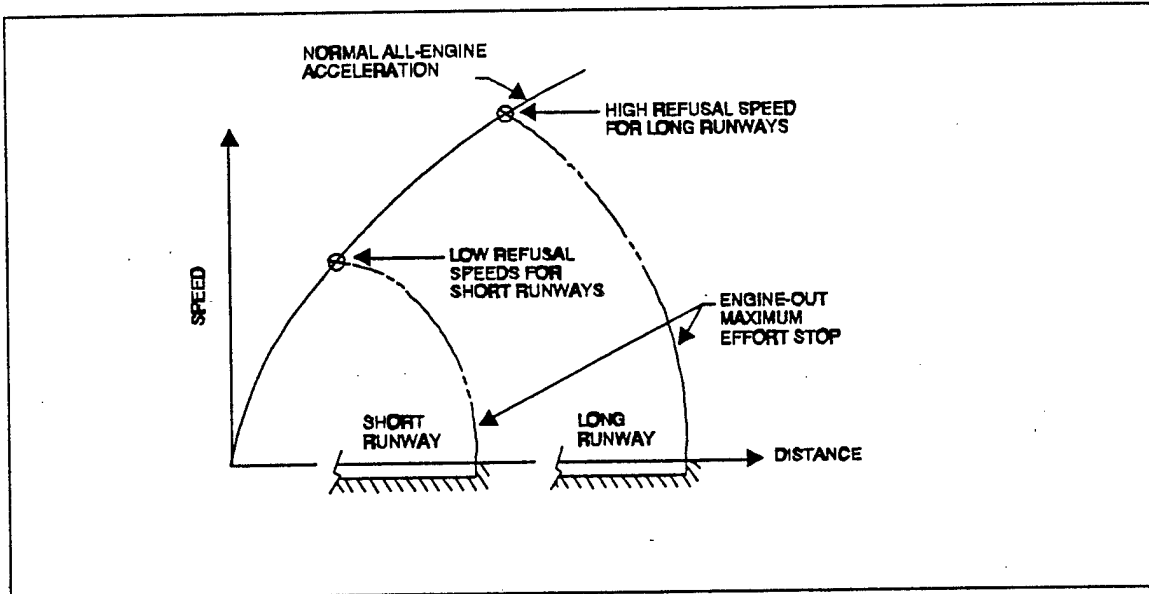

FIGURE 11.1 REFUSAL SPEED

11.2.2.2 Continuation Speed

Now consider the same aircraft attempting the takeoff under identical conditions. There is also a minimum speed to which it can accelerate on all engines, lose the critical engine, and then continue the takeoff with the engine failed, becoming airborne at the far end of the runway. This speed, the continuation speed, varies with runway length in a manner opposite that of refusal speed, i.e., it is relatively low for long runways (Figure 11.2).

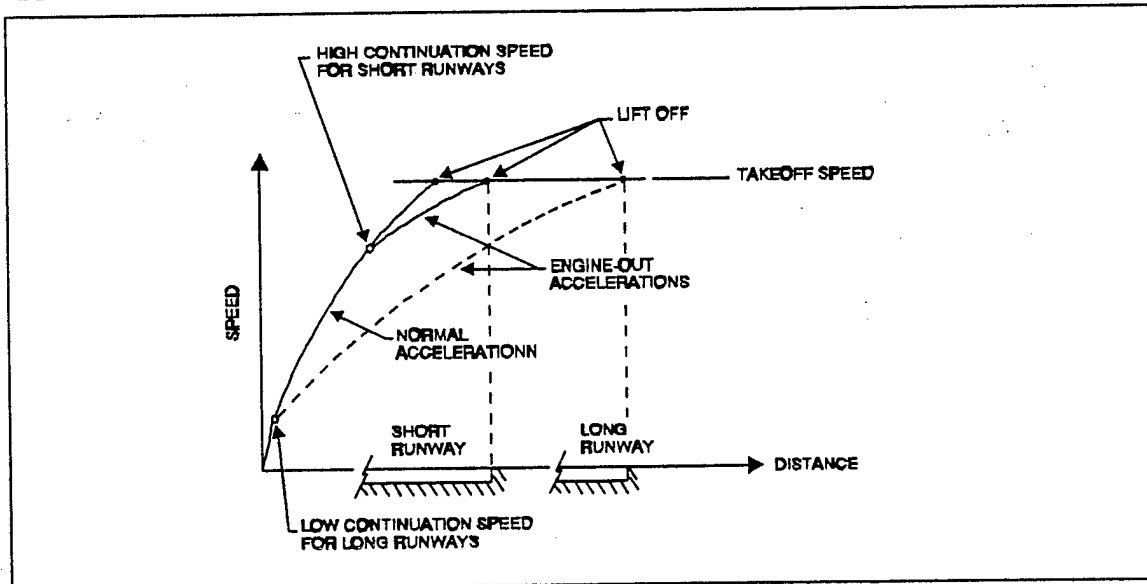

FIGURE 11.2 CONTINUATION SPEED

The gap between the continuation speed and the refusal speed reflects the size of the safety margins provided by a given runway for the particular conditions (Figure 11.3).

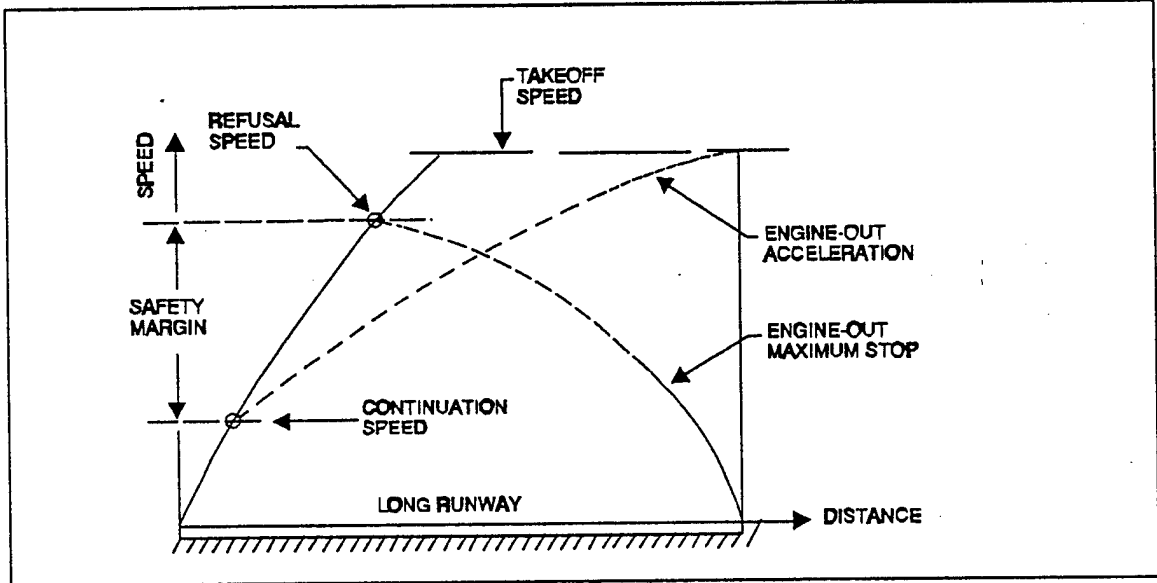

FIGURE 11.3 TAKEOFF SAFETY MARGIN

Obviously, if the runway is very short and the refusal speed is less than the continuation speed, a situation exists where neither a safe takeoff nor an abort can be made if an engine failure occurs between the two speeds (Figure 11.4).

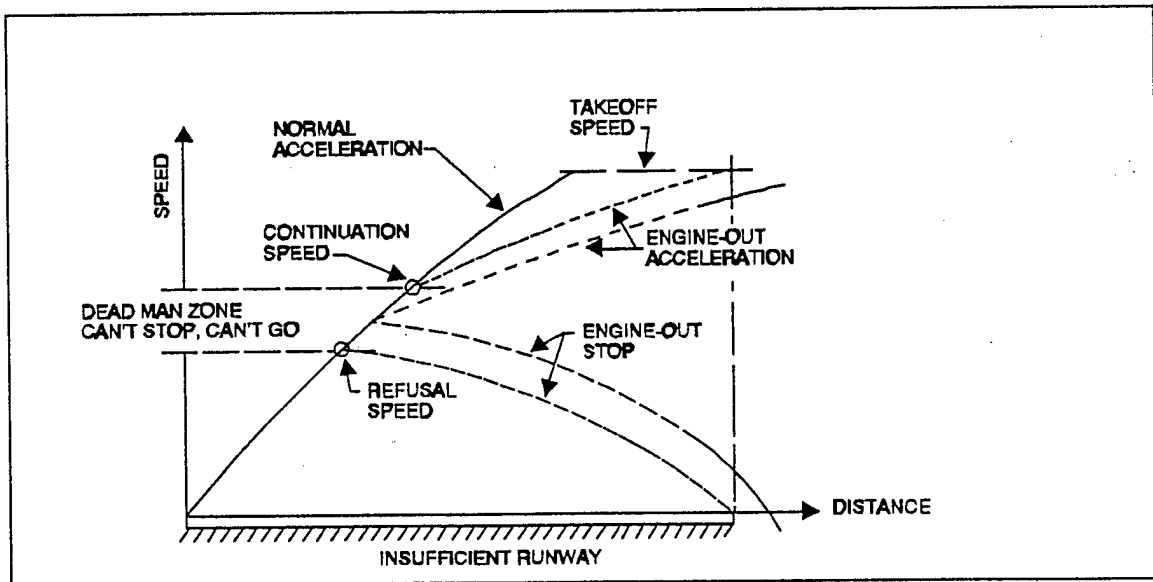

FIGURE 11.4 TAKEOFF DEAD MAN ZONE

11.2.2.3 Critical Field Length

The military normally uses a distance called Critical Field Length (CFL) to enable the pilot to immediately determine if the runway length is sufficient to provide a safety.

margin. The CFL is the total runway required to accelerate to a given speed, lose an engine, then continue the takeoff or abort in the same distance. The speed used in the CFL definition is the critical engine failure speed (V_{CEF}) (Figure 11.5).

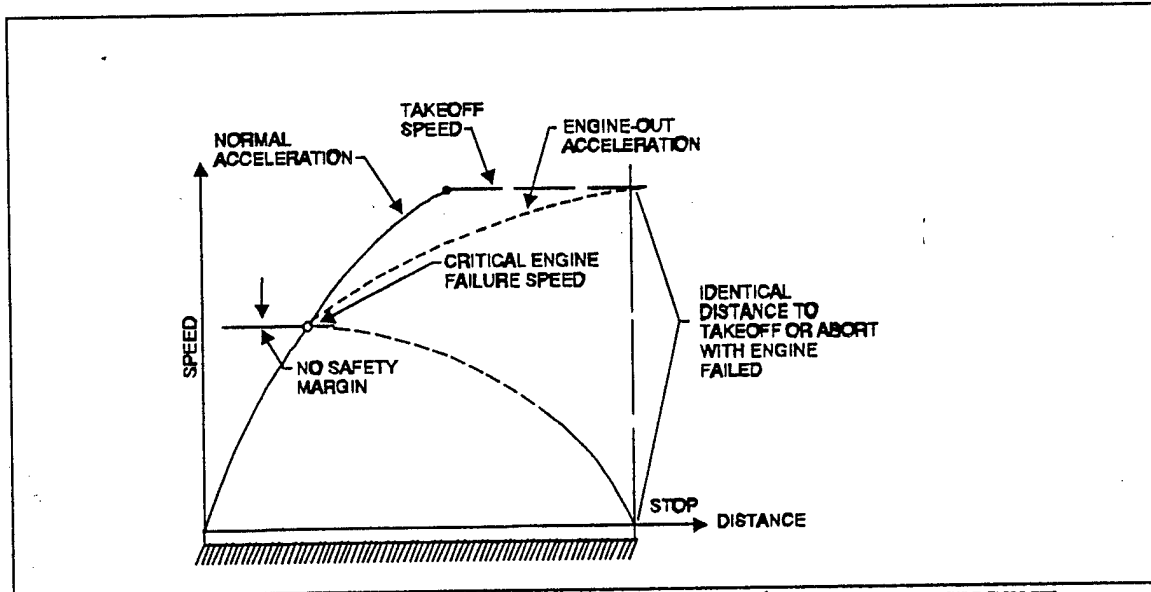

FIGURE 11.5 CRITICAL FIELD LENGTH/CRITICAL ENGINE FAILURE SPEED

11.2.2.4 Decision Speed

The next term to define is decision speed. During the design of the aircraft flight manual, the operational authority must decide at what particular speed will the course of action change from abort to continue the takeoff in the event of engine failure. Decision speed (V_1) is the speed at which the pilot must decide whether to continue the takeoff or abort. Decision speed usually guarantees the pilot V_{CEF} or ground minimum control speed. If V_1 is below V_R , as shown in Figure 11.6, then a safety zone exists such that the pilot can either takeoff or abort.

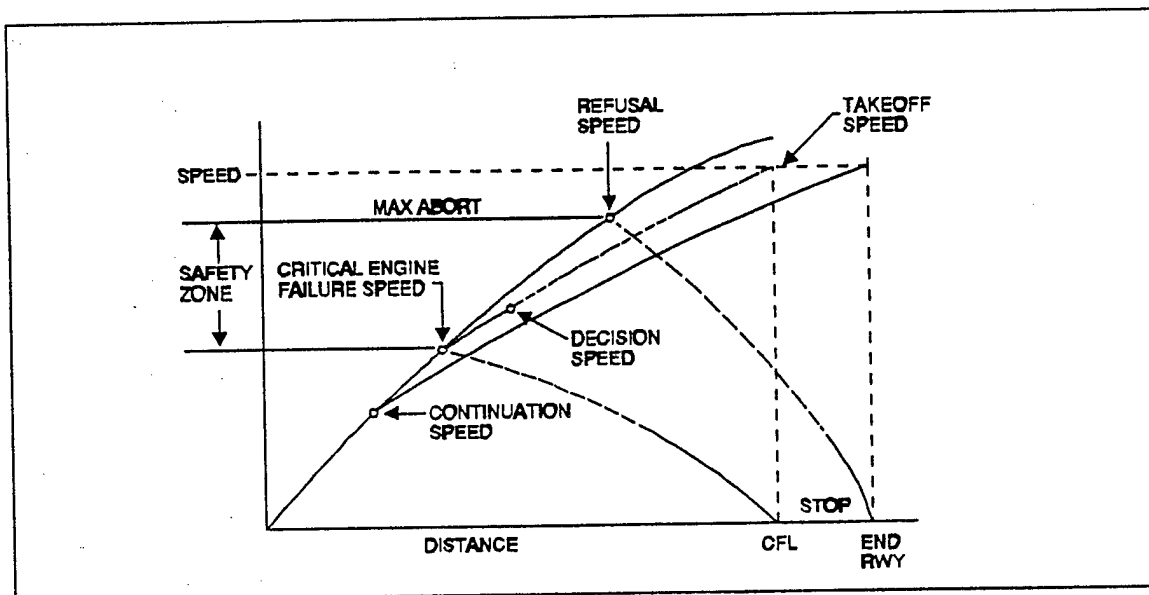

FIGURE 11.6 DECISION SPEED

If the initial climb performance is going to be critical on the takeoff, the decision point may be near the higher speed end of the safety margin (Figure 11.7).

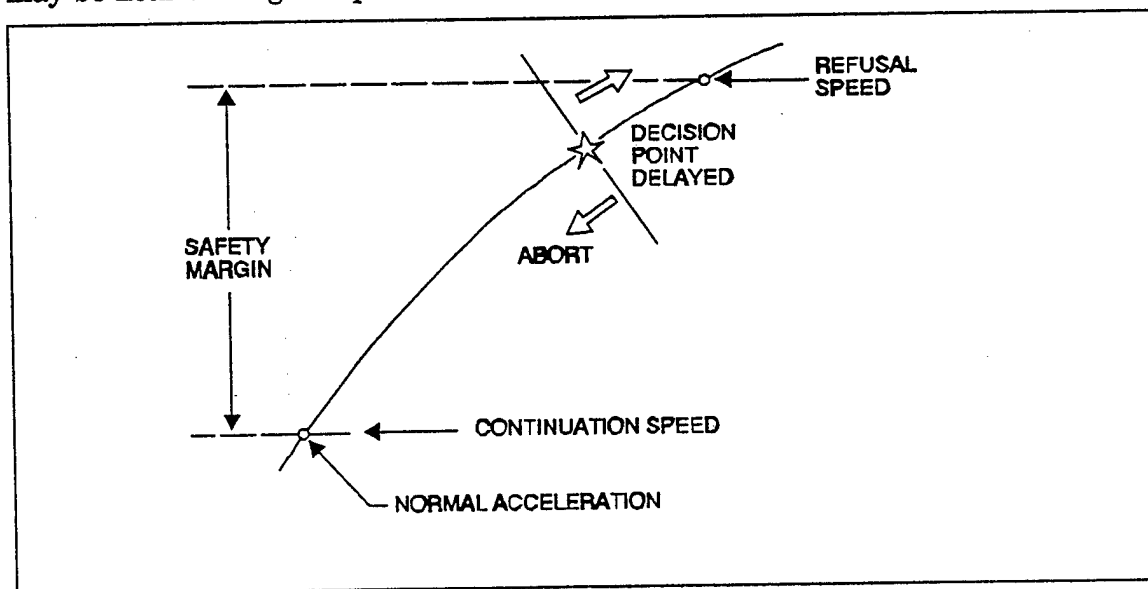

FIGURE 11.7 HIGH DECISION SPEED

The B-47 illustrates the opposite case. This aircraft had a very poor record for successful aborts and was operated with the decision speed relatively near the low speed end of the safety margin (Figure 11.8).

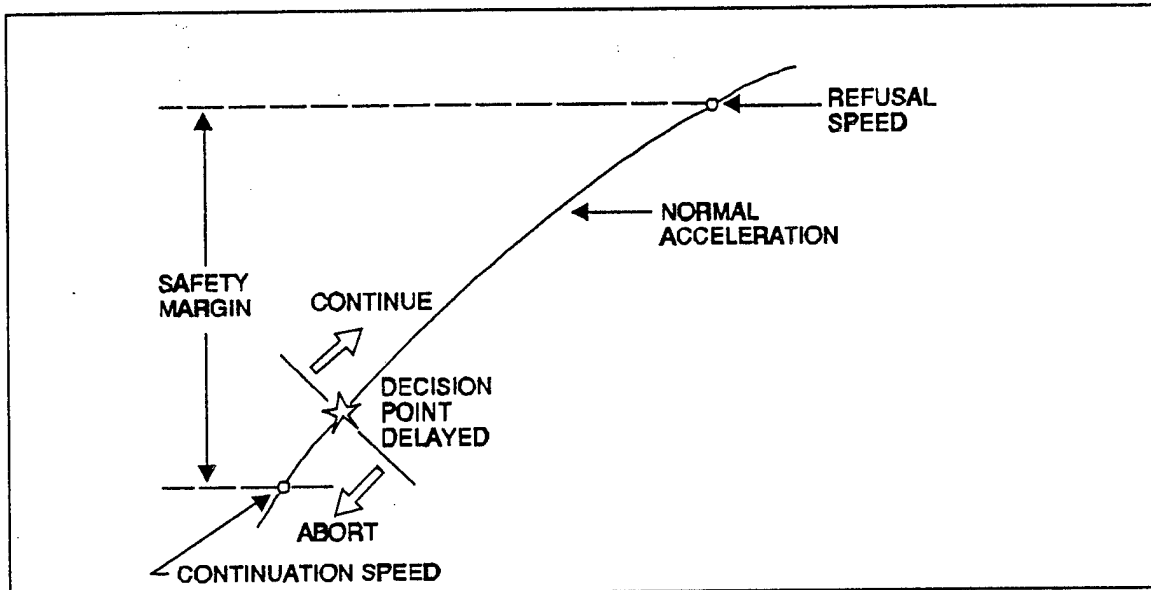

FIGURE 11.8 LOW DECISION SPEED

11.2.3 Climb Performance

What about the initial climb segment after becoming airborne? The period between lift-off and attaining best engine-out climb speed can be very critical. Major air commands normally specify a minimum authorized rate of climb between 200 and 500 feet per minute for engine-out operations. The level of performance allows little margin for mismanagement of attitude or configuration. Flap retraction should be incremental on a very tight speed schedule to keep sufficient lift for a positive climb gradient without excessive drag. Unexpected characteristics may be encountered in this phase. For example, the additional drag due to opening doors might make it desirable to delay gear retraction until late in the cleanup phase. In another instance, the time available to obtain the clean configuration might be limited by the supply of water injection fluid if dry thrust is insufficient to maintain the climb. Careful flight test exploration of this phase is an obvious requirement.

11.3 THE CONTROL PROBLEM

To maintain control of an aircraft after an engine failure the flight controls must be used to balance the asymmetric moments generated by the operating engine. An aircraft's flight controls should be effective in balancing the inoperative engine throughout its normal operating envelope. Limits may be placed on the aircraft's envelope in the air or on the ground, and caused by a loss of either directional or lateral control. The control problem is evaluated in a steady state and in a dynamic case. The dynamic case is just an extension of the steady state case due to rates and accelerations incurred during pilot reaction time. It will generally dictate the larger control inputs than the steady state case.

Figure 11.9 shows the typical forces and moments during an engine out.

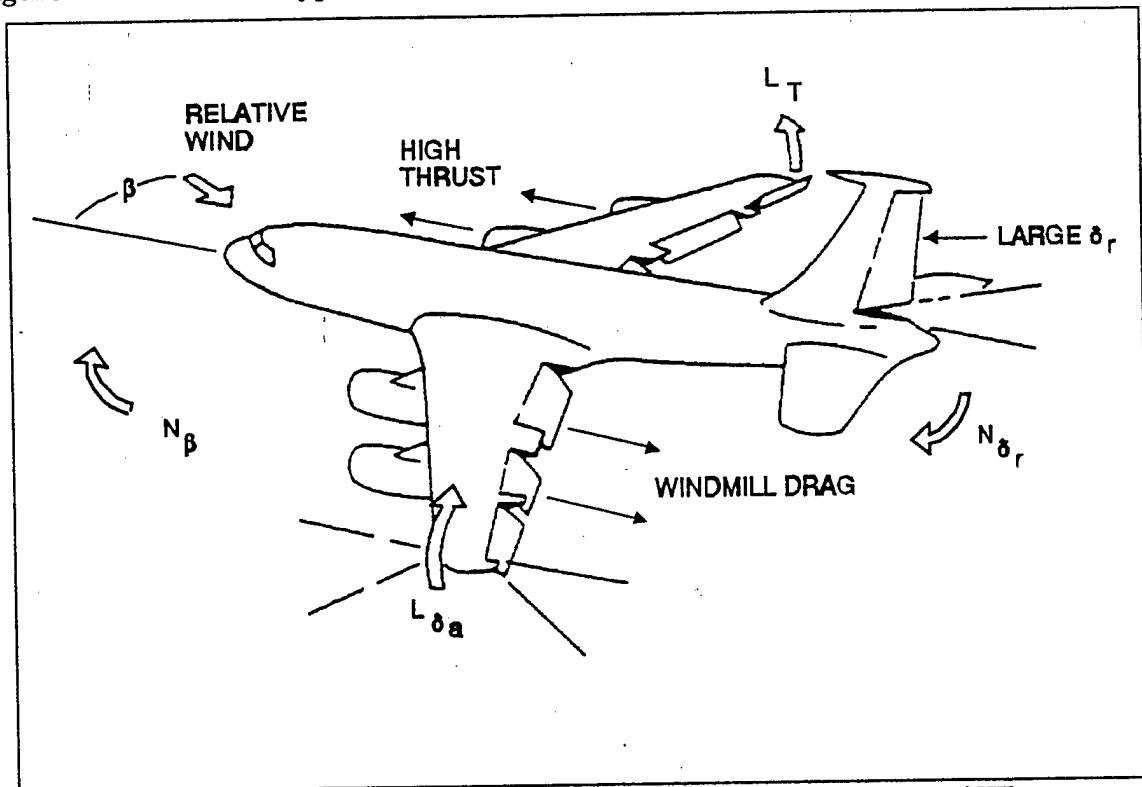

FIGURE 11.9 TYPICAL YAWING MOMENTS ENGINE OUT

Notice that the moment created by asymmetric thrust is opposed by a rudder moment and that the rudder force is opposed by the side force generated by the side slip angle at equilibrium. The yawing moment due to the failed engine is a function of basic engine parameters, temperature and pressure altitude. The other forces and moments are a function of airspeed and bank angle.

11.3.1 Steady State Equations of Motion

The Equations of Motion (EOM) are the starting point for examination of the asymmetric thrust condition. The longitudinal axis not vital when examining engine out control problems. The longitudinal equations are balanced by the usual techniques for stabilized flight. The lateral-directional EOM are of most interest in achieving equilibrium during engine out conditions. From Chapter 4, the lateral-directional EOM for a wings level steady state condition are:

$$\text{"YAWING MOMENT"} \quad N_{\beta}\beta - \frac{I_{xz}}{I_x}\ddot{\phi} - N_r\dot{\phi} + \dot{r} - N_r r = N_{\delta_a}\delta_a + N_{\delta_r}\delta_r \quad (4.153)$$

$$\text{"SIDE FORCE"} \quad \beta - Y_{\beta}\beta - Y_p\dot{\phi} - Y_{\dot{\phi}}\phi + (1 - Y_r)r = Y_{\delta_a}\delta_a + Y_{\delta_r}\delta_r \quad (4.151)$$

$$\text{"ROLLING MOMENT"} \quad L_{\beta}\beta + \ddot{\phi} - L_p\dot{\phi} - \frac{I_{xz}}{I_x}\dot{r} - L_r r = L_{\delta_a}\delta_a + L_{\delta_r}\delta_r \quad (4.152)$$

The term N_r , yawing moment due to asymmetric thrust is introduced. Also the term $Y_{\dot{\phi}}\phi$ is translated to $W \sin \phi$, a sideforce from the lateral component of the weight vector due to bank angle. We make the following assumptions to simplify these equations for our investigation:

1. Torque and gyroscopic effects due to rotating engines or propellers are neglected.
2. Sideforce due to aileron deflection, δ_a is neglected.
3. The restriction of steady, unaccelerated flight with all rates equal to zero is imposed.

The three lateral-directional force and moment equations can be now be written as:

$$\text{"YAWING MOMENT"} \quad N_r + N_{\delta_a}\delta_a + N_{\delta_r}\delta_r + N_{\beta}\beta = 0 \quad (11.1)$$

$$\text{"SIDE FORCE"} \quad Y_{\delta_r}\delta_r + Y_{\beta}\beta + W \sin \phi = 0 \quad (11.2)$$

$$\text{"ROLLING MOMENT"} \quad L_{\delta_a}\delta_a + L_{\delta_r}\delta_r + L_{\beta}\beta = 0 \quad (11.3)$$

The yawing moment equation and sideforce equation (11.1 and 11.2) are the primary balancing equations for directional control with an engine inoperative. They are balanced with combinations of yaw control deflection (δ_r), sideslip (β) and bank angle (ϕ). The roll equation (11.3), is balanced by roll control deflection (δ_a). Though usually not critical, roll control power could limit lateral controllability.

The lateral-directional equations with asymmetric thrust suggest there are four variables δ_r , δ_a , ϕ , β , and only three equations. A common way out of this dilemma is to fix one variable and solve for the other three. We will use this technique to investigate the affects of bank angle on equilibrium.

11.3.2 Effects of Bank Angle on Equilibrium

To see the effects of bank angle on equilibrium, three cases are of particular interest:

Case 1: $\phi = 0$

Case 2: $\beta = 0$

Case 3: $F_r = 0$

Case 1: $\phi = 0$

Figure 11.10 shows the forces and moments for Case 1, the zero bank angle case, with the left engine inoperative. The aircraft is in equilibrium with no accelerations. The pilot would note this with constant heading, ball centered, turn needle centered, rudder opposing the inoperative engine and aileron opposite the rudder to keep the wings level.

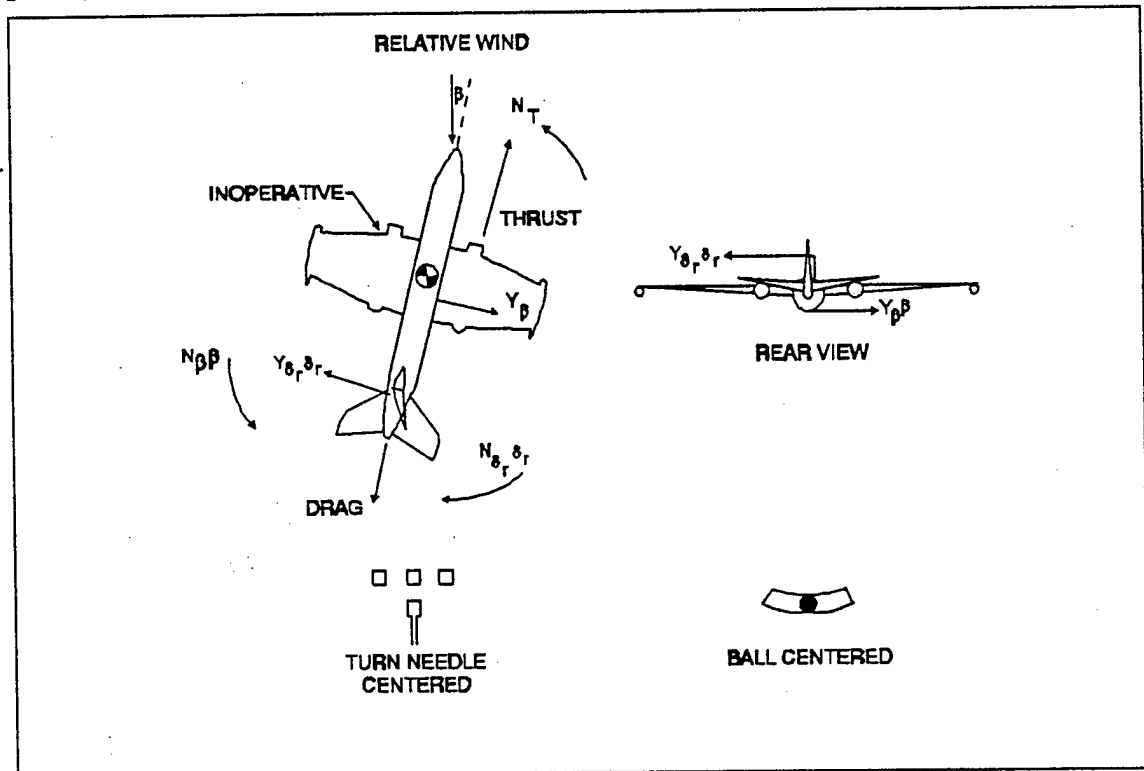

FIGURE 11.10 EQUILIBRIUM FLIGHT WITH WINGS LEVEL

The negative yawing moment generated by the failed engine will be balanced by a positive rudder deflection. The rudder deflection causes a negative sideforce that is balanced by the sideforce due to sideslip. For the zero bank angle case, the yawing and sideforce equations become:

$$N_T + N_{\delta_r} \delta_r + N_{\delta_a} \delta_a + N_{\beta} \beta = 0 \quad (11.4)$$

$$Y_{\delta_r} \delta_r + Y_{\beta} \beta = 0 \quad (11.5)$$

These equations can be solved simultaneously to determine the control deflections and sideslip required for balanced equilibrium flight. Assuming δ_a produces very little yawing moment:

$$\delta_r = \frac{N_T + N_{\beta} \beta}{N_{\delta_r}} \quad (11.6)$$

$$\beta = \frac{N_T Y_{\delta_r}}{N_{\delta_r} Y_{\beta} - N_{\beta} Y_{\delta_r}} \quad (11.7)$$

When the appropriate numbers are substituted for derivatives, for a failed left engine (a negative N_T) β will be negative.

Case 2: $\beta = 0$

Another way to balance the sideforce resulting from rudder deflection is by using the $W \sin \phi$ term in the sideforce equation (11.3). Figure 11.11 shows the forces and moments for the zero sideslip case.

The aircraft is in equilibrium with some bank toward the operating engine, a constant heading and the turn needle centered. The rudder deflection is in the same direction as in the Case 1, however, less δ_r is required. The ball in the turn and slip indicator will be deflected in the direction of the bank angle.

With sideslip equal to zero, the yaw and sideforce equations become:

$$N_T + N_{\delta_r} \delta_r = 0 \quad (11.8)$$

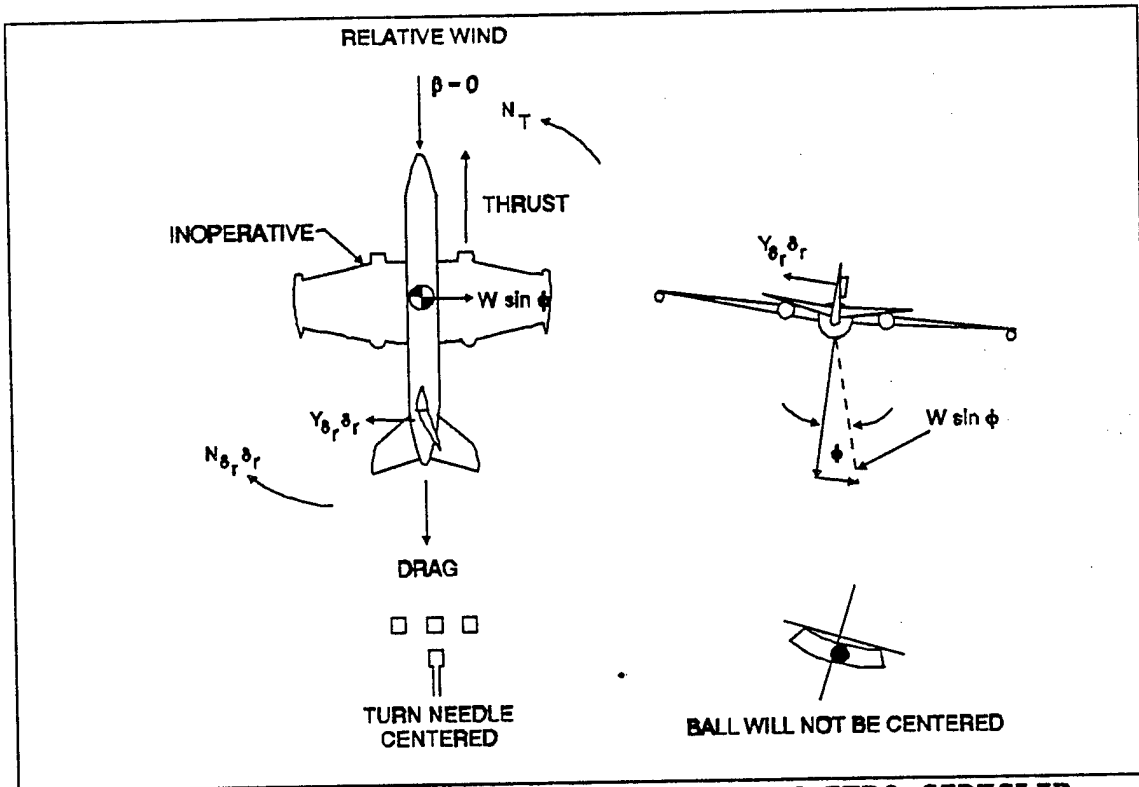

FIGURE 11.11 EQUILIBRIUM FLIGHT WITH ZERO SIDESLIP

$$Y_{\delta_r} \delta_r + W \sin \phi = 0 \tag{11.9}$$

These equations can be solved to determine the amount of bank required to reduce the sideslip to zero:

$$\delta_r = -\frac{N_T}{N_{\delta_r}} \tag{11.10}$$

and

$$W \sin \phi = \frac{Y_{\delta_r} N_T}{N_{\delta_r}} \tag{11.11}$$

therefore:

$$\sin \phi = \frac{Y_{\delta_r} N_r}{W N_{\delta_r}} \quad (11.12)$$

Three important conclusions can be made from the previous discussion. First, bank angle can reduce the amount of rudder required to achieve equilibrium. Second, an increase in weight reduces the amount of bank required to reduce the sideslip to zero. Third, this configuration will have the least amount of drag. With $\beta = 0$, no sideforce is generated, and therefore no drag due to sideforce is created.

Case 3: $F_r = 0$

The last case to be examined is with zero rudder force. With a irreversible flight control system, δ_r will also be zero. With a reversible system, some rudder deflection will result because of sideslip being produced, however for the purposes of our discussion δ_r will be considered equal to zero.

Figure 11.12 shows the forces and moments for Case 3. The aircraft is in equilibrium with rudder force equal to zero, constant heading, turn needle centered. The bank angle required to achieve this steady state condition is considerable more than required in Case 2. Also note the ball in the turn and slip will be deflected slightly more in the direction of the bank.

With rudder force and δ_r equal to zero, the yaw and sideforce equations become:

$$N_r + N_{\beta} \beta = 0 \quad (11.13)$$

$$Y_{\beta} \beta + W \sin \phi = 0 \quad (11.14)$$

These equations can be solved to determine the amount of bank required to achieve equilibrium with $F_r = 0$.

$$\beta = -\frac{N_r}{N_{\beta}} \quad (11.15)$$

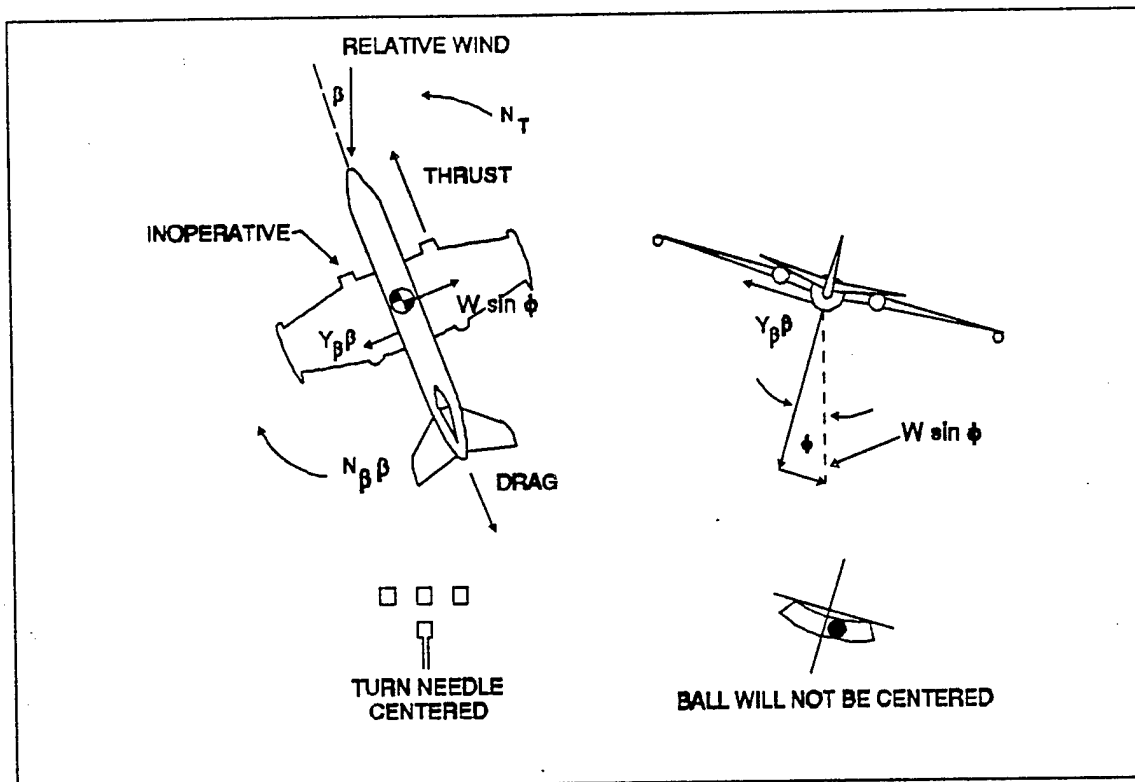
FIGURE 11.12 EQUILIBRIUM FLIGHT WITH $F_x = 0$

$$\sin \phi = \frac{Y_\beta N_T}{W N_\beta} \quad (11.16)$$

From the above equations it can be seen that for a failed left engine (negative N_T) β must be positive to balance the equation. The amount of sideslip developed in this case is considerably more than in Case 1 ($\phi = 0$). Also to balance the sideforce equation the bank angle must be positive. The amount of bank required to achieve $F_x = 0$ is also more than required to achieve $\beta = 0$. Given these two points, it should be recognized that this is the highest drag condition of the three cases discussed. Another thing to consider is the possibility of fin stall and loss of directional control due to the high sideslip and bank angles produced during this case.

It is important to note that for any asymmetric thrust condition there are numerous combinations of rudder deflection and bank angle that will balance the equations of motion. However, for a given bank angle there is only one rudder deflection that will result in equilibrium (steady state) flight.

11.3.3 Air Minimum Control Speed (V_{mca})

MIL-STD-1797A borrows this definition of air minimum control speed from FAR part 25:

"The calibrated airspeed, at which, when the critical engine is suddenly made inoperative, it is possible to recover control of the airplane with that engine still inoperative, and maintain straight flight with zero yaw, or at the option of the applicant, with an angle of bank of not more than five degrees".

Note that "recover" and "maintain" are used in the definition of air minimum control speed referring to a dynamic and static case. For a given set of asymmetric thrust conditions, V_{mca} is the speed below which aerodynamic controls are insufficient to maintain equilibrium. Figure 11.13 is a typical plot that shows the yawing moments due to asymmetric thrust and maximum rudder deflection as a function of airspeed.

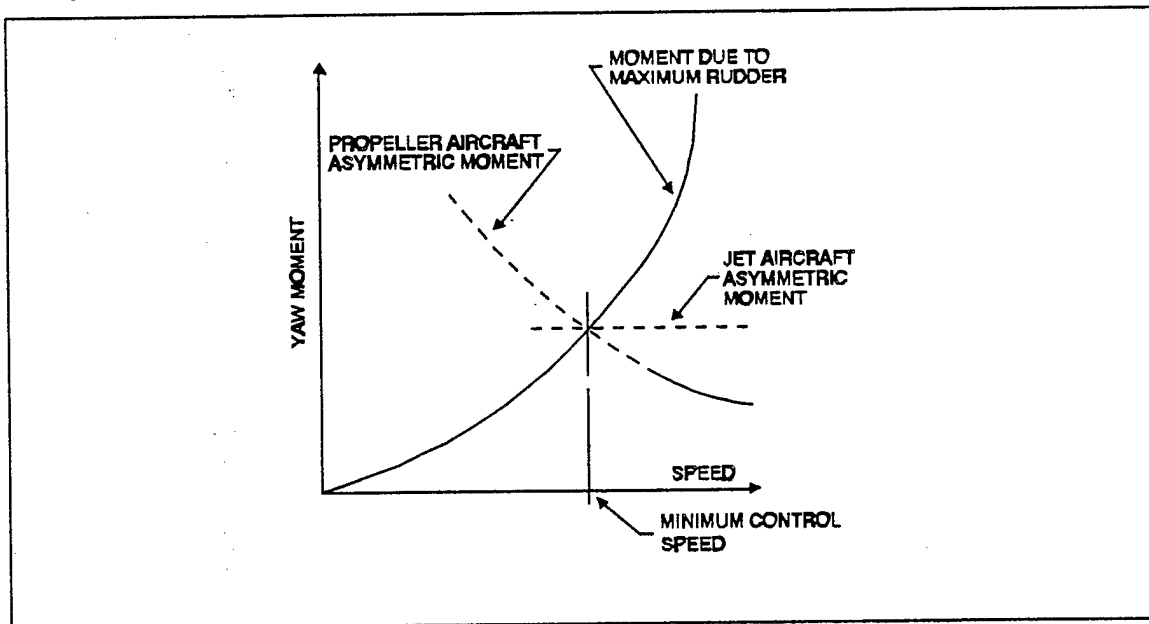

FIGURE 11.13 YAWING MOMENTS IN-FLIGHT

11.3.3.1 Critical Engine

The critical engine for a jet aircraft is most always an outboard engine. The only exception might be when the failure of an inboard engine also fails the sole hydraulic boost to a rudder system. In addition, for propeller driven aircraft the critical engine is defined by the direction of propeller rotation. "P-Factor" is the unequal thrust distance from centerline due to rotation. For clockwise rotating propellers the most critical engine would be the left outboard.

11.3.3.2 Aircraft Design

The aircraft's design dictates whether the air minimum control speed will be defined by loss of directional control or lateral control. Directional controllability is the normal concern of aircraft with conventional airfoil and engine configurations such as the KC-10 or C-141. These aircraft reach a limit to directional control (yaw control power) with adequate lateral control remaining.

Lateral controllability is more of a concern in an aircraft with a blown wing or powered lift such as the C-130 or the C-17. Loss of an engine on these aircraft directly affects the lift generated by that wing. Large asymmetric rolling moments caused by an inoperative engine can lead to loss of lateral control (insufficient roll control power) at airspeeds significantly higher than normal approach speed.

The effects of bank angle in determining the lowest possible air minimum control speed also differ between these designs. The following paragraphs contrast the controls and bank required for the lowest air minimum control speed.

11.3.3.3 Directional Control Limits

The air minimum control speed for an aircraft which is limited by yaw power is achieved by maximum useable rudder deflection and bank into the operative engine(s). Assume that airspeed is allowed to decrease below the minimum control speed for the wings level configuration in Figure 11.14.

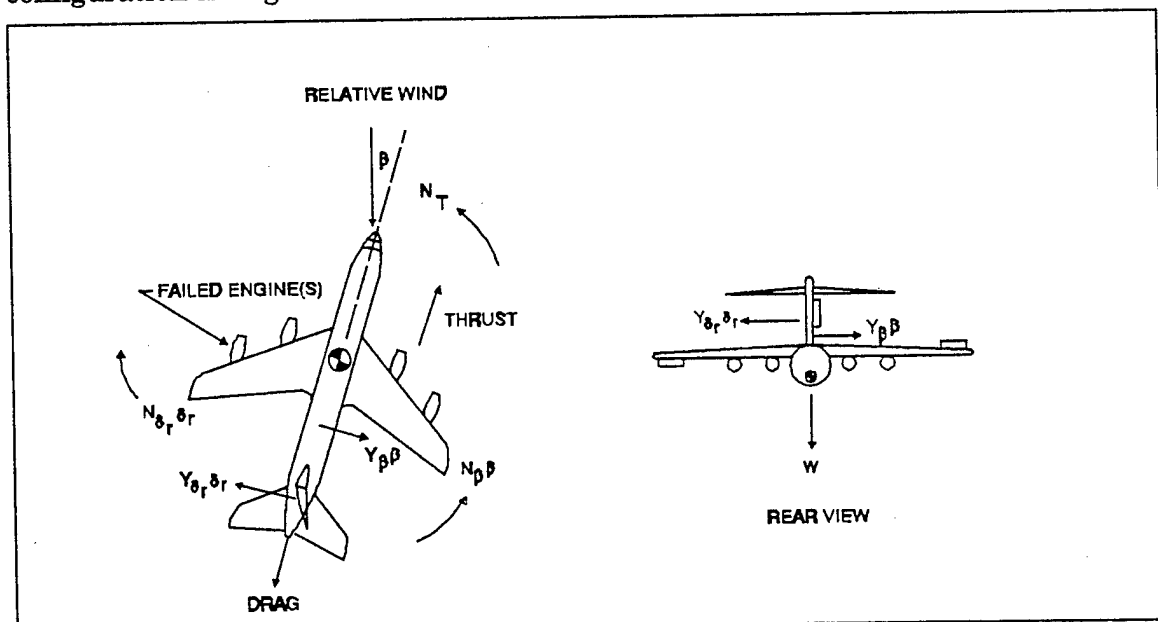

FIGURE 11.14 DIRECTIONAL MINIMUM CONTROL SPEED WINGS LEVEL

With the left engine failed as shown, the aircraft will now begin to yaw left since no additional rudder power is available to balance the yawing moment generated by the operative engines. Recalling Case 2 ($\beta = 0$), equilibrium is regained by using the banked component of weight to reduce the sideslip. This reduces the moment due to sideslip and therefore allows the reduced rudder yawing moment to reestablish equilibrium. Minimum directional control speed is defined when the bank angle reaches 5 degrees into the good engines. This normally results in a small sideslip into the good engines as shown in Figure 11.15.

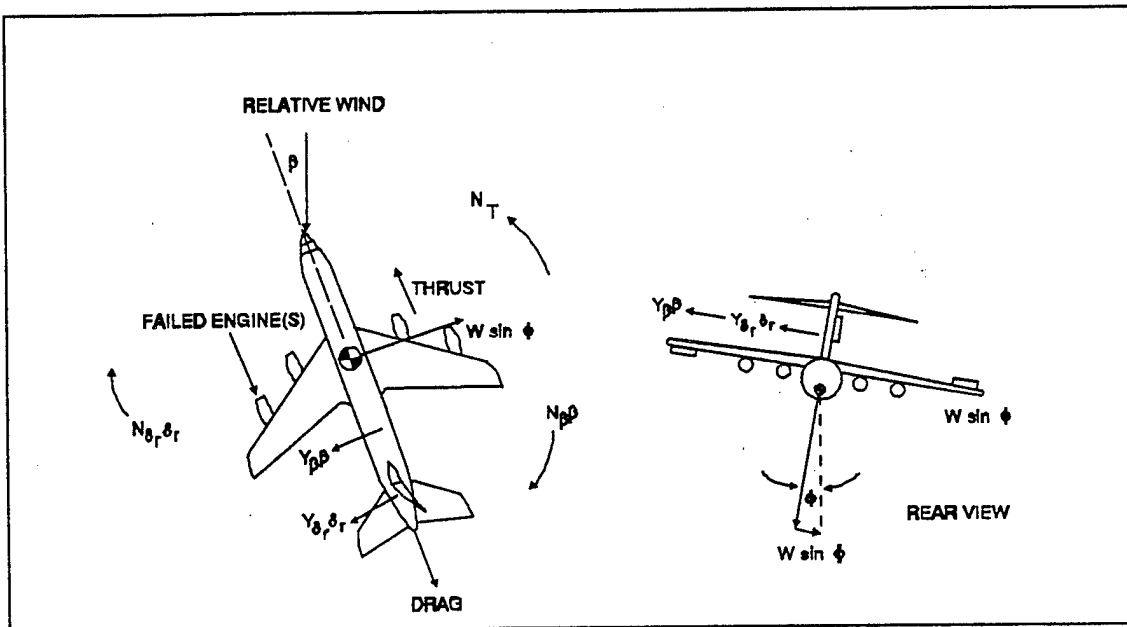

FIGURE 11.15 AIR MINIMUM DIRECTIONAL CONTROL SPEED FOR WINGS BANKED 5 DEGREES

11.3.3.4 Lateral Control Limits

The air minimum control speed for an aircraft which is limited by roll power is achieved by maximum useable lateral control deflection and bank into the inoperative engine(s). The situation for lateral minimum control speed is illustrated in Figure 11.16. This situation is the same as illustrated in Figure 11.14 for the directional control speed case except that now, minimum control speed is defined when the maximum allowable lateral control deflection is reached. The propulsive rolling moment, L_T shown in Figure 11.16 is that generated by propulsive lift and must be balanced by the lateral control deflection and also the rolling moment due to sideslip.

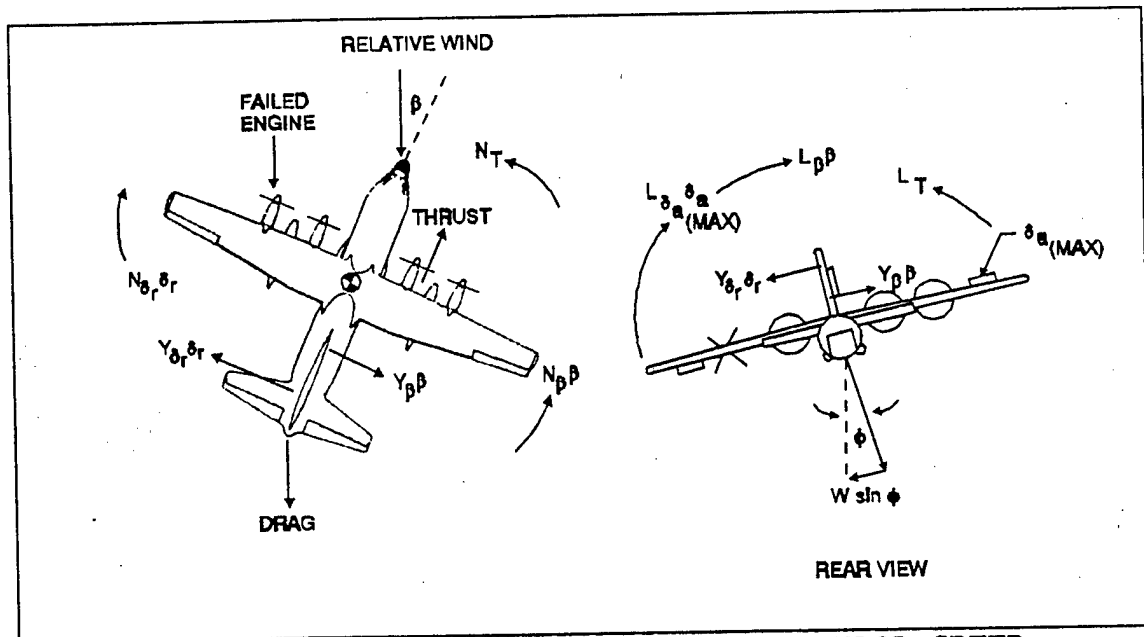

FIGURE 11.16 AIR MINIMUM LATERAL CONTROL SPEED

Assume that airspeed is allowed to decrease below the minimum lateral control speed for the wings-level configuration and that additional rudder power is available. With the left engine(s) failed as shown, the aircraft will now begin to roll left since no more lateral control is allowable to balance the propulsive rolling moment. The aircraft will begin to roll and yaw left. As right rudder is added to stop the yaw, sideslip will increase into the inoperative engine(s). The additional rolling moment due to sideslip, L_{β} acts to bring the aircraft back into lateral equilibrium. Minimum lateral control speed is defined when the bank angle reaches 5 degrees away from the good engines. This normally results in a strong sideslip into the bad engines as shown in Figure 11.16.

11.3.3.5 Factors Affecting Air Minimum Control Speed

We have previously discussed the effects of bank angle on V_{mca} . This speed will also vary based on weight, altitude, the number of asymmetric engines inoperative, and maximum useable control deflection. Decreasing the aircraft's weight has the same affect as decreasing the bank angle. $W \sin \phi$, the banked component of weight is less effective in reducing the sideslip. The moment due to sideslip increases and a higher airspeed is required for the rudder yawing moment to maintain equilibrium. As aircraft weight goes down, V_{mca} airspeed goes up.

Decreasing altitude increases the thrust available on the operating engines, increasing the yawing moment to be overcome. As aircraft altitude goes down, V_{mca} airspeed goes up.

Similarly, the loss of a second asymmetric engine on a four engine transport will increase the yawing moment to overcome by rudder. As the thrust asymmetry goes up, V_{mca} airspeed goes up.

Rudder pedal or aileron force limits (rudder or aileron hinge moment limits on irreversible flight control systems) might limit the useable control deflection that can be used to balance the yawing or lateral moment. As usable control deflection goes down, V_{mca} airspeed goes up.

Figure 11.17 depicts a typical aircraft V_{mca} chart. It shows for a given bank angle and altitude, V_{mca} is a function of the engine thrust moment and gross weight. Note the area of the chart where V_{mca} is not applicable and the aircraft is controllable to stall speed.

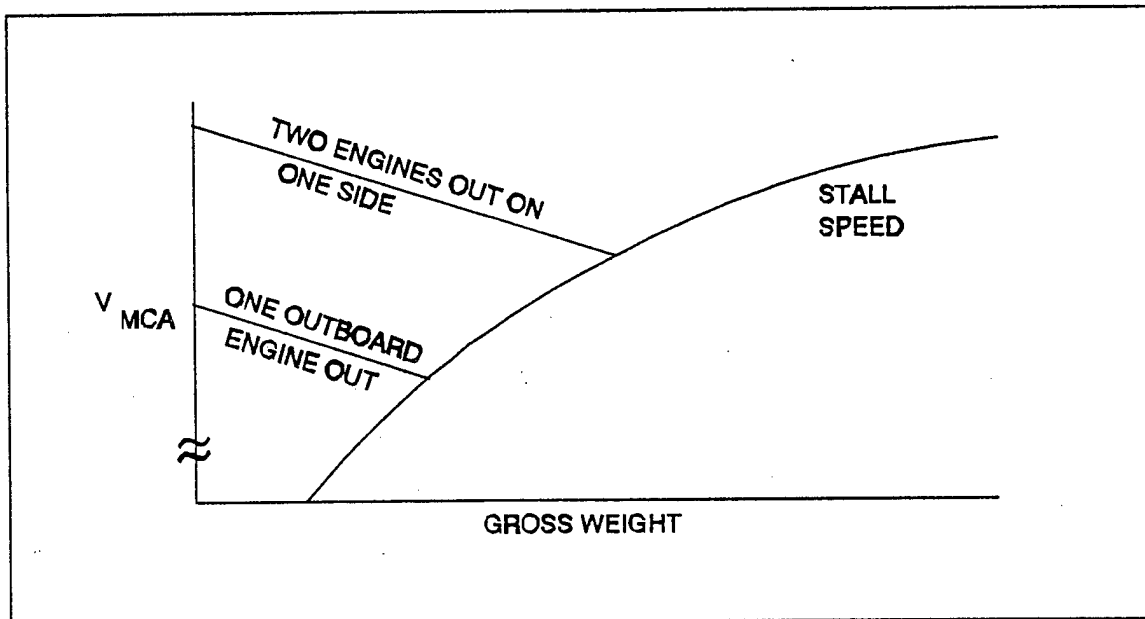

FIGURE 11.17 AIR MINIMUM CONTROL SPEED VERSUS GROSS WEIGHT

11.3.4 Dynamic Engine Failure

As stated earlier, the dynamic case is an extension of the steady state case due to rates and accelerations incurred during pilot reaction time. Before an aircraft can achieve equilibrium, the pilot must first overcome these rates and accelerations. The dynamic case usually requires more control authority and may require the use of a higher V_{mca} speed than the steady state case.

One of the most important and controversial variables when considering the dynamic engine failure is the response time. Response time might not be critical with an engine failure at cruise but, is far more crucial when the failure occurs during takeoff or go-around. The following discussion and guidance is excerpted from MIL-STD-1797A, paragraph 4.1.11.4, "Failures". Total response time to a failure is the sum of aircraft response time and pilot response time intervals. The minimum total response time for evaluations should be 1 second. Table 11.2 is reproduced from MIL-STD-1797A.

11.3.4.1 Aircraft Response Time

This is the time period between the failure occurring and the pilot being alerted by a suitable cue. The cue may take the form of an adequate tactile, audio or visual warning. The eye should not be relied upon to detect unusual instrument indications. In the absence of adequate cues listed, the pilot can be considered alerted when the aircraft meets or exceeds the responses listed in Table 11.2.

11.3.4.2 Pilot Response Time

Pilot response time is especially critical in defining a reasonable minimum pilot intervention time (delay time) to a failure. The status of the pilot in the overall task of controlling the aircraft can be described as active or attended operation, divided attention operation (both hands on and hands off the controls), or unattended operation such as autopilot mode (both hands on and hands off the controls).

As an example, if a pilot is flying the final approach to landing, he is performing attended operation with his hands on the controls. If he engages an autopilot mode during the approach, he is now performing unattended operation. Should a failure occur during this operation, the pilot response time for a corrective control input would be quite small because his hands would be on or in close proximity to the controls. It would be reasonable to assume a pilot response time of 1/2 second. However, if the failure occurred at cruise on a cross country leg, this unattended operation would assume that the pilots hands are not in close proximity to the controls. In this case, a pilot response time of 2 1/2 seconds is more reasonable. Table 11.2 provides suggested values of pilot response times to failures for various phases of flight.

Table 11.2 Summary of Minimum Allowable Intervention Times

PHASE OF FLIGHT	AIRCRAFT RESPONSE $t_1 - t_0$	PILOT RESPONSE $t_2 - t_1$	MINIMUM ALLOWABLE INTERVENTION DELAY TIME AND METHOD OF TEST
Attend Operation	Time for aircraft to achieve change of rate about any axis of 3 deg/sec OR The time to reach a change of "G" in any axis of 0.2 OR For an attention getter to function	1/2 sec	System failures will be injected without warning to the pilot. His ability to recover as rapidly as possible without a dangerous situation developing will be used to assess system failure mode acceptability.
Divided Attention Operations Hands On	Time for aircraft to achieve change of rate about any axis of 3 deg/sec OR The time to reach a change of "G" in any axis of 0.2 OR For an attention getter to function	1-1/2 sec (Decision 1 plus reaction 1/2)	The pilot will be warned of the system failure. Demonstration of compliance must show that an intervention delay time equal to 1 1/2 sec + $(t_1 - t_0)$ can be tolerated
Divided Attention Operation Hands On		2-1/2 sec (Decision 1-1/2 plus reaction 1)	As above but intervention delay time 2 1/2 seconds + $(t_1 - t_0)$
Unattended Operation Hands On	As above but the threshold rates and "G" values are 5 deg/sec and 0.25 respectively	2-1/2 sec (Decision 2 plus reaction 1/2)	As above.
Unattended Operation Hands Off		4 sec (Decision 3 plus reaction 1)	As above but intervention delay time 4 sec + $(t_1 - t_0)$

11.3.5 Ground Minimum Control Speed (V_{mcg})

Ground minimum control theory is more complicated. The rudder moment and asymmetric thrust moments are related the same as the in-flight case, but nose wheel steering can help oppose the asymmetric thrust moment, landing gear opposes side force, and crosswind can greatly affect the rudder moment available.

If the crosswind is in the direction of the failed engine, less rudder deflection is available to counteract the moment from the engine loss because some rudder is being used to correct the weathercock tendency caused by the crosswind component. Figure 11.18 depicts the major yawing moments encountered on the ground.

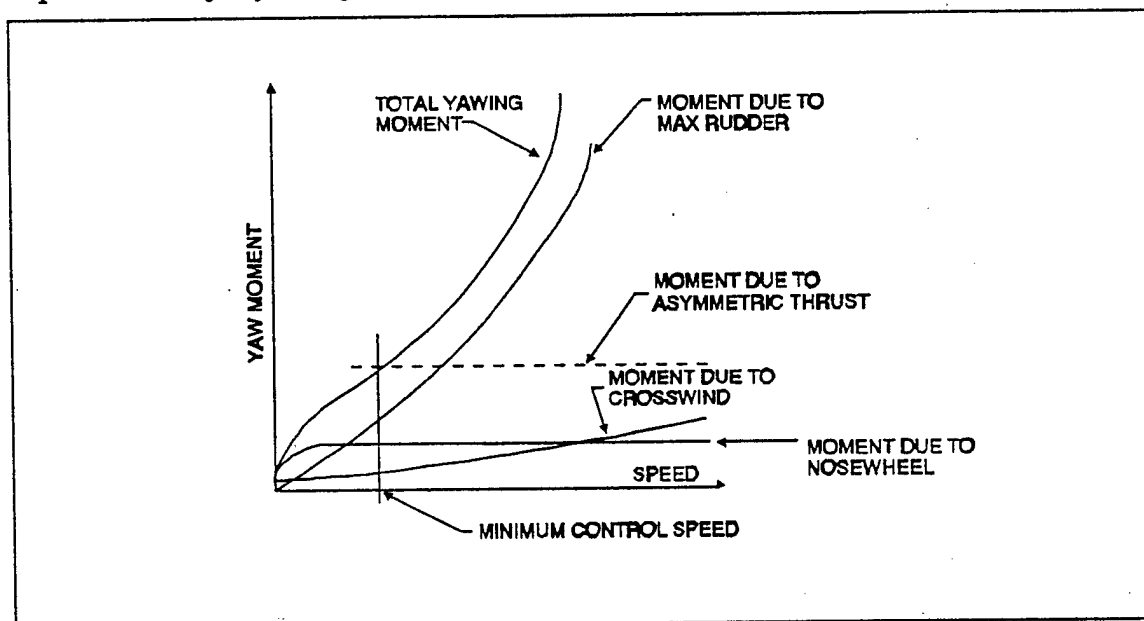

FIGURE 11.18 YAWING MOMENTS ON THE GROUND

11.4 ENGINE OUT MILITARY STANDARDS

MIL-STD-1797A places limits on control forces and deflections useable in controlling an aircraft with an inoperative engine. Useable rudder deflection is limited by a maximum allowable rudder force of 180 pounds. Useable lateral control is restricted to 75% of roll control power available, with a maximum lateral force of 20 pounds allowed. In the case of aircraft with irreversible control systems, the maximum control forces can be evaluated before flight. Pertinent MIL-STD-1797A guidance for engine out evaluations are contained in Table 11.3.

Table 11.3 Engine Out Guidance MIL-STD-1797A

4.1.11.4	Failures
4.1.13.5	Trim for Asymmetric Thrust
4.5.8.4	Roll Axis Control Power for Asymmetric Thrust
4.5.9.5.5	Roll Axis Control Force Limits for Asymmetric Thrust
4.6.5.1	Yaw Axis Response to Asymmetric Thrust
4.6.6.2	Yaw Axis Control Power for Asymmetric Thrust
4.6.7.8	Yaw Axis Control Power for Asymmetric Thrust During Takeoff
4.8.4.2.4	One Engine Out Stalls

11.5 ENGINE OUT FLIGHT TESTING

Military aircraft are usually designed with relatively low safety margins in order to obtain optimum performance. In fact, during war emergency operation the gross weight may be so high that engine out operation is not possible at all. Flight tests of these critical phases, on or near the ground, require a high level of crew skill and proficiency. Each test point must be carefully planned and flown. Such tests are an important part of the developmental testing of a new aircraft. They play a vital role in the side by side evaluation of assault or V/STOL transports where the ability to carry a useful load into and out of a landing area is frequently limited by engine out performance. Individual evaluations to determine if an aircraft meets the contractors guarantees may also hinge on this area of operation.

11.5.1 In-flight Performance

Some flight test programs may require demonstration of an engine out takeoff capability. Critical after takeoff climb gradients should be evaluated by an aircraft performance modeling program before a decision for demonstration of that climb gradient is made. Sawtooth climbs are often used to gather data in areas of low predicted climb performance. Normal performance flight test methods may be used to determine range and endurance with an engine(s) inoperative.

11.5.2 Stall Evaluation

An evaluation of the engine out stall characteristics should be made prior to V_{mca} testing. Evaluation should be made using standard flight test methods for stall but with low to moderate thrust set on the operative engine. Stall should be approached cautiously,

noting differences in control forces, deflections and effectiveness from the all engines operating case. Note any departure tendencies and recovery techniques required.

11.5.3 Landing Performance

Restricted reversing capability, and higher approach speeds required to maintain minimum safe speeds will affect landing performance. Normal flight test methods are valid, but caution must be exercised in go-around situations, especially at light gross weights.

11.5.4 Air Minimum Control Speed

Flight test is required to ensure an aircraft's compliance with the specification and to verify contractor data from wind tunnel or flight test. Static V_{mca} should be evaluated first. Once the test team is satisfied it has accurately predicted static V_{mca} they can move to an evaluation of dynamic V_{mca} .

As we have seen, it is possible for a multiengine aircraft to have no air minimum control speed because that aircraft can be controlled down to aerodynamic stall. This is the desired situation, however it is important in this case not to report the aerodynamic stall speed as the minimum control speed.

Prior to flight test, consideration must be given to the hazards associated with shutting down engines in flight. On a twin engine aircraft, these hazards may be such that it should not be shutdown. Careful analysis should allow for the simulation of engine shutdown by idle thrust.

Consideration should be given to performing these tests at a variety of gross weights and altitudes. If the aircraft has a rudder power assist system or yaw augmentation, the profile should be repeated with these systems "off".

Once again, MIL-STD-1797A borrows the following additional guidance from FAR part 25 for the most appropriate configuration for flight test of air minimum control speed:

- a) Most unfavorable center of gravity (normally an aft c.g);
- b) The airplane trimmed for takeoff;
- c) In the most critical configuration in takeoff flight path except gear may be retracted.
- d) If applicable, the propeller of the inoperative engine:
 - (1) Windmilling;
 - (2) The most probable position for the specific engine design; or
 - (3) Feathered, if the aircraft has an automatic feathering system.

As with the engine-out stall evaluation, flight test of V_{mca} should be approached cautiously. In most cases the aircraft is very close to stall with full rudder deflection. Plan and discuss control, trim and throttle movements during and at the completion of the test points. Review all stall and departure recovery techniques prior to flight.

11.5.4.1 Static Air Minimum Control Speed

It has been shown that an aircraft with an engine inoperative can be stabilized in straight unaccelerated flight using various combinations of bank angle and rudder deflections. Data taken from these stabilized point can be "normalized" and plotted to predict V_{mca} airspeeds for all combinations of bank, gross weight, altitude, and engines inoperative. There are several methods of collecting engine-out data. Experience, the type of control system (reversible or irreversible) or instrumentation installed may dictate what method to use. The following two methods are based on traditional engine-out FTTs. They are the "varying airspeed" and the "constant airspeed" techniques.

11.5.4.1.1 Varying Airspeed Technique

At an airspeed well above predicted V_{mca} , maximum asymmetric thrust is established by shutting down, or simulating the shutdown of the most critical engine(s) and setting the other symmetric engines to maximum thrust for the test condition. With the aircraft in the specified configuration a series of stabilized wings level points are flown decreasing to the airspeed at which maximum rudder deflection (or aileron deflection limit) occurs. Once the wings level point has been recorded, continue the deceleration by banking into the operative engine(s). Use stall speed or 5 degrees of bank to define as the limit.

11.5.4.1.2 Constant Airspeed Technique

The airspeed is stabilized at $1.1 V_{stall}$ in the specified configuration with thrust set for level flight. A small asymmetric thrust differential is established from the trim setting. Slowly apply maximum rudder deflection and bank the aircraft to reestablish a steady heading. The bank may be initially into the failed engines. Once data is recorded, incrementally increase the thrust differential and once again establish a steady heading. Terminate the test when maximum asymmetric thrust or 10 degrees of bank is reached.

11.5.4.1.3 Data Recorded

Data recorded at each stable point should include:

- a) engine parameters
- b) rudder force and deflection
- c) aileron force and deflection
- d) pressure altitude
- e) temperature

- f) gross weight
- g) bank angle

11.5.4.2 Dynamic Air Minimum Control Speed

The objectives of flight test are to anticipate operational problems, duplicate realistic time delays, and arrive at an air minimum control speed and recovery technique that provides the average pilot a safe margin. The only realistic way to evaluate dynamic engine failure is to flight test it.

MIL-STD-1797A requires that a pilot be able to avoid dangerous conditions that might result from sudden loss of an engine during flight. The method of test compliance is to stabilize at an airspeed approximately 20 knots above static V_{mca} with symmetric power and suddenly fail the most critical engine. After observing a realistic time delay for realization and diagnosis, the pilot arrests the aircraft motion and achieves engine out equilibrium.

The test team must consider the average pilot's ability to arrest the motion and return the aircraft to equilibrium. The minimum airspeed at which the test team believes adequate control power is available in the dynamic situation should be considered in the final determination of air minimum control speed. The test should be repeated at an incrementally reduced speed until a minimum airspeed or static V_{mca} is reached.

If static V_{mca} was determined to be below stall speed a dynamic V_{mca} evaluation should still be performed. The aircraft should be stabilized at $1.1 V_s$ and the above method used to evaluate control power available.

11.5.5 Ground Minimum Control Speed

V_{mcg} will vary from the flight value because of :

- a) The inability to use sideslip or bank angle.
- b) Crosswind components.
- c) The additional yaw moment produced by the landing gear.

This varies with landing gear configuration, the amount of steering used, the vertical load on the gear, and the runway condition. There are three basic methods for V_{mcg} testing:

- a) Acceleration method
- b) Deceleration method
- c) Throttle chop method

11.5.5.1 Acceleration Method

Some high performance aircraft accelerate in the test condition and the acceleration method is required. The asymmetric yawing moment is gradually increased (by throttle manipulation) as increasing speed allows more control. The speed where sufficient control is available to hold full asymmetric power is the ground minimum control speed. This method requires considerable skill and coordination to obtain good results since the aircraft is at minimum control speed through out the acceleration.

11.5.5.2 Deceleration Method

If the aircraft will decelerate with the asymmetric power condition set up (symmetric pairs of non critical engines may also be retarded), the back in method may be used. The test is started at a speed in excess of the expected V_{mcg} and the power condition set. As the speed decreases, more aerodynamic control deflection is required. The speed at which directional control can no longer be maintained is V_{mcg} .

11.5.5.3 Throttle Chop Method

The first two methods are considered static tests since no yaw rates or accelerations are allowed to develop. The third method though it relies heavily on good estimates of V_{mcg} more accurately predicts the dynamic affects of engine failure on the ground. An incremental test speed above the predicted V_{mcg} is chosen. The test aircraft is accelerated on all engines to this speed and the critical engine chopped. Since the aircraft is above the predicted speed, it should be easily controlled. If so the aircraft proceeds to the next point incrementally to the predicted value of V_{mcg} . If at any speed down to the predicted speed the aircraft deviates more than 30 feet with full controls being used, the test is aborted. In this case the final successful point should be used for V_{mcg} . Since test pilots are performing these tests, knowing that an engine failure will occur, additional pilot response time should be added. The minimum acceptable response time for operational use should be one second.

11.6 ENGINE OUT DATA ANALYSIS

11.6.1 Thrust Moment Analysis

The analysis of minimum control speed data can be easily extrapolated to off-standard day conditions if it is expressed in non-dimensional form. Thrust moment (N_T) may be non-dimensionalized by the following equation:

$$C_{n_r} = \frac{N_T}{qSB} \quad (11.17)$$

where

q = dynamic pressure, lb/ft²

S = wing area, ft²

b = wing span, ft

The steady state equations of motion for the asymmetric power condition are:

$$C_{l_p} \beta + C_{l_{\dot{\alpha}}} \delta_a + C_{l_{\dot{r}}} \delta_r = 0 \quad \text{Roll} \quad (11.18)$$

$$C_{n_r} + C_{n_p} \beta + C_{n_{\dot{r}}} \delta_r + C_{n_{\dot{\alpha}}} \delta_a = 0 \quad \text{Yaw} \quad (11.19)$$

$$C_{y_p} \beta + C_{y_{\dot{r}}} \delta_r + C_L \sin \phi = 0 \quad \text{Sideforce} \quad (11.20)$$

At high angles of attack and low airspeeds

$$C_{l_{\dot{r}}} = 0$$

Solving Equation 11.18 for δ_a and equation 11.20 for β , and substituting these relations into Equation 11.19 yields

$$C_{n_r} = K_1 \delta_r + K_2 C_L \sin \phi \quad (11.21)$$

Where K_1 and K_2 are constants containing the stability derivatives in the original three equations. To clarify this equation, we recall that the original assumption was that the aircraft was in steady unaccelerated flight with all rates equal to zero. We introduce the term " $C_{n_{\dot{r}}}$ " to depict the aircraft's aerodynamic yawing moment, or its ability to balance an asymmetric engine such that:

$$C_{n_r} = C_{n_{\dot{r}}} \quad (11.22)$$

Then:

$$C_{n_{\dot{r}}} = K_1 \delta_r + K_2 C_L \sin \phi \quad (11.23)$$

Equation 11.23 shows that $C_{n_{\dot{r}}}$ is a unique function of rudder deflection, lift coefficient, and bank angle.

Prior to commencing the flight test phase, an engine thrust deck is required (Figure 11.19).

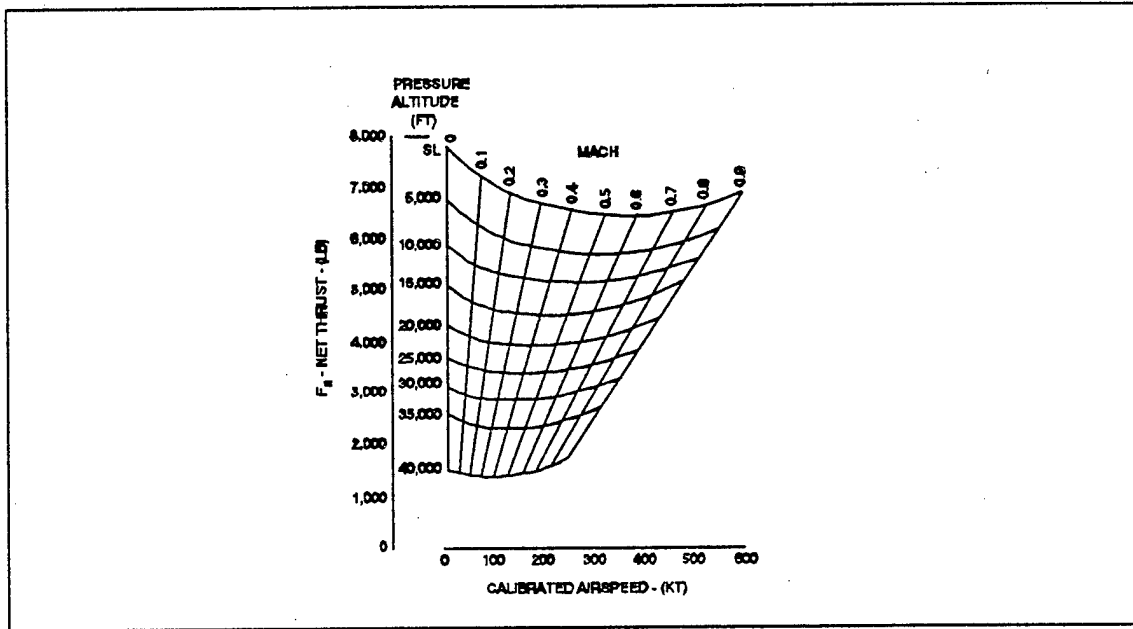

FIGURE 11.19 ENGINE THRUST DECK

Thrust moment coefficient is then easily calculated by Equation 11.17, and may be presented like that in Figure 11.20. This same information can be gathered by instrumenting the engine for thrust measurement.

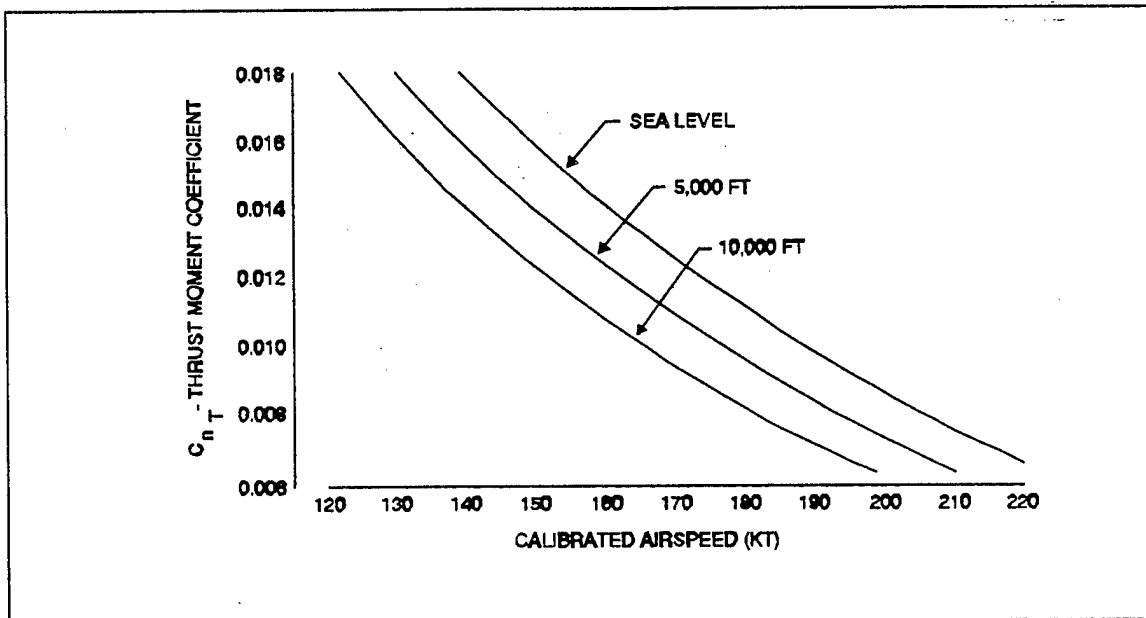

FIGURE 11.20 THRUST MOMENT COEFFICIENT VERSUS AIRSPEED

11.6.2 Irreversible Control System

During flight test, the rudder deflection required for a wings-level equilibrium point with asymmetric thrust is defined. The locus of all stabilized points represents a curve (Figure 11.21) on which the thrust moment coefficient must be exactly balanced by the associated rudder deflection. Note for a given airplane and thrust level, a coefficient can be identified as the maximum allowable using full rudder.

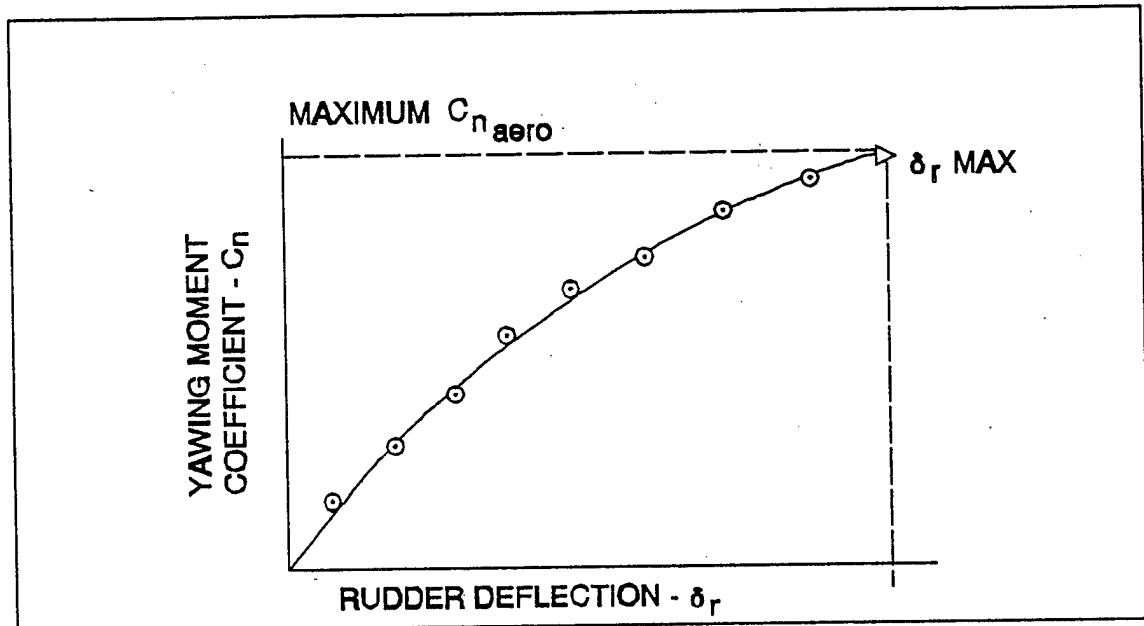

FIGURE 11.21 YAWING MOMENT COEFFICIENT VERSUS RUDDER DEFLECTION

At each altitude in Figure 11.20 there is a maximum value of $C_{n_{aero}}$, the aerodynamic yawing moment coefficient, that can exactly balance C_{n_r} . This value of $C_{n_{aero}}$ defines the slowest airspeed in which the aircraft can stabilize in wings level. This discussion addresses only wings level flight and therefore, no weight effects were present. To determine the effects of aircraft weight the $C_L \sin \phi$ term of Equation 11.23 must be considered.

The yawing moment coefficient from the banked flight test data is calculated the same way as for the wings level data and plotted versus $C_L \sin \phi$ as shown in Figure 11.22.

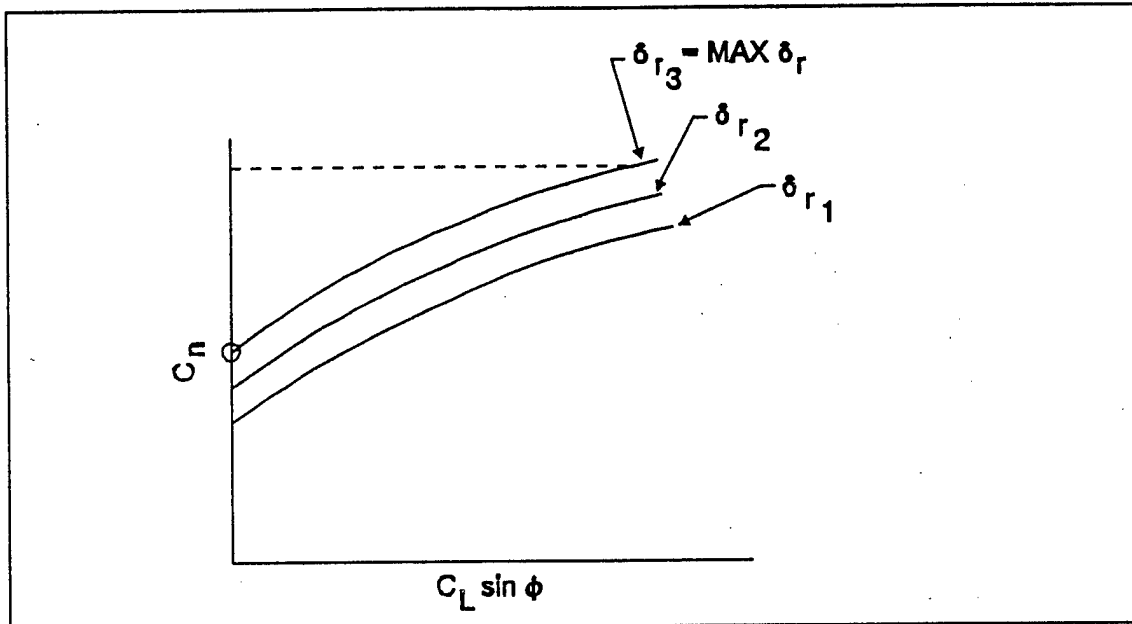

FIGURE 11.22 YAWING MOMENT COEFFICIENT VERSUS BANKED LIFT COEFFICIENT

In actual flight testing to determine values for the flight manual, only the data gathered at maximum rudder deflection is necessary (in this case δ_{r_3}). One important anchor point of this plot is the maximum $C_{n_{\dots}}$ determined from the wings level data analysis previously accomplished. This point is plotted at $C_L \sin \phi$ equal to zero. Also, note from the plot that as bank angle increases ($C_L \sin \phi$ increasing), the yawing moment coefficient for maximum δ_r increases, which corresponds to a decrease in minimum control speed.

11.6.2.1 Weight Effects

We can use the plot of C_n and $C_L \sin \phi$ to determine weight effects on V_{mca} . For any gross weight, altitude and bank angle, there is a unique value of $C_{n_{\dots}}$ associated with steady flight and full asymmetric thrust. If a gross weight, altitude and bank angle are assumed, it is possible to compute and plot a line whose slope intercepts a unique value of $C_{n_{\dots}}$ and $C_L \sin \phi$.

To determined the slope of this line given:

$$C_n = \frac{F_n l}{q S b} \quad \text{and} \quad C_L \sin \phi = \frac{W \sin \phi}{q S}$$

Then:

$$\begin{aligned} \frac{C_n}{C_L \sin \phi} &= \frac{F_n l}{q S b} * \frac{q S}{W \sin \phi} \\ &= \frac{F_n l}{b W \sin \phi} \\ &= m \quad (\text{i.e. slope}) \end{aligned}$$

Therefore:

$$C_n = m C_L \sin \phi \quad \text{Where:} \quad m = \frac{F_n l}{b W \sin \phi}$$

Figure 11.23 depicts these lines of constant altitude and bank angle as a function of gross weight with $GW_3 > GW_1$. Note from this plot that as gross weight increases the maximum $C_{n_{max}}$ increases, which corresponds to a decrease in minimum control speed.

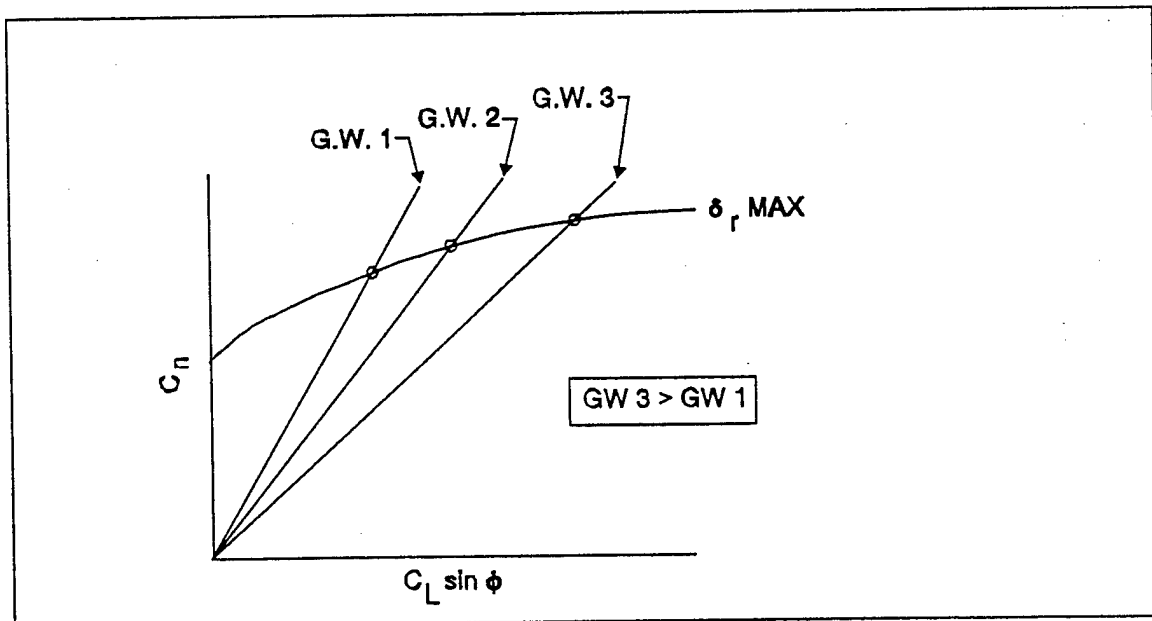

FIGURE 11.23 WEIGHT EFFECTS ON YAWING MOMENT

11.6.2.2 Altitude Effects

Another way to analyze the data is to plot variations of $C_{n_{yaw}}$ and $C_L \sin \phi$ at constant gross weight and bank angle as a function of altitude as shown in Figure 11.24.

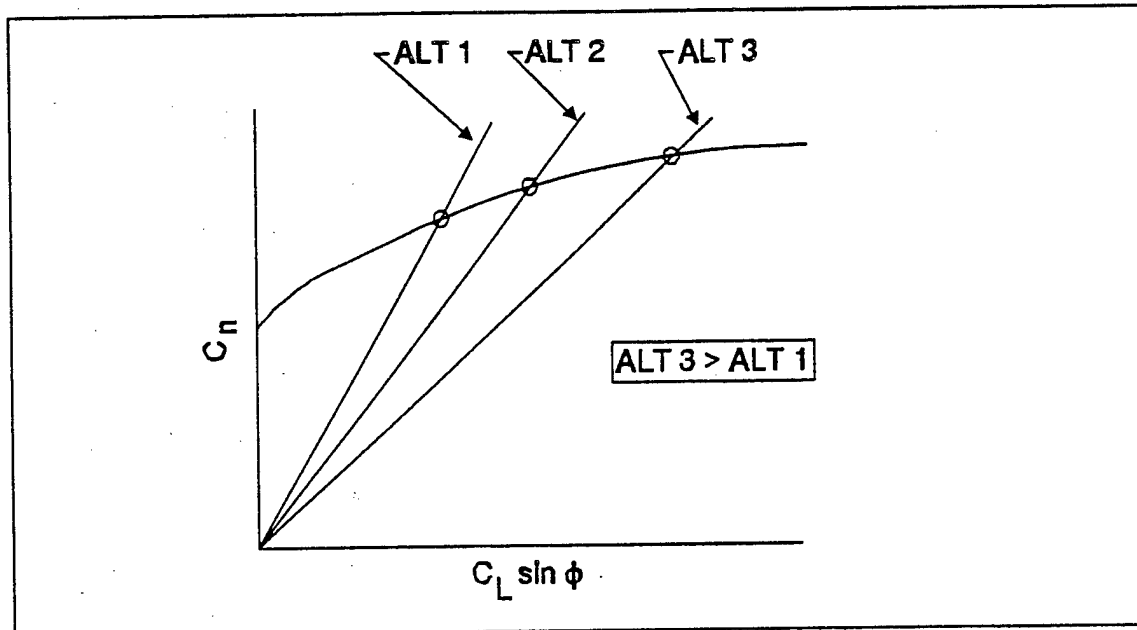

FIGURE 11.24 ALTITUDE EFFECTS ON YAWING MOMENT

These lines represent lines of constant altitude with $ALT\ 3 > ALT\ 1$. As altitude increases engine thrust decreases, causing the slope to decrease. The intercept is now a higher value of $C_{n_{yaw}}$. The higher value of $C_{n_{yaw}}$ corresponds to a lower V_{ncr} .

11.6.3 Reversible Control Systems

For aircraft with reversible control systems, the equation for rudder pedal force, F_r , is:

$$F_r = -GqS_r \bar{c}_r (b_1 \alpha_r + b_2 \delta_r) \quad (11.24)$$

By an analysis similar to that above for thrust moment coefficient it can be shown that a rudder pedal force coefficient (C_{F_r}) can be defined as:

$$C_{F_r} = \frac{F_r}{qS_r} = K_3 \delta_r + K_4 C_L \sin \phi \quad (11.25)$$

Equation 11.25 shows that C_{F_r} , like $C_{n_{max}}$, is a unique function of rudder deflection, lift coefficient, and bank angle.

The speed at which the rudder force limit, 180 lbs imposed by MIL-STD-1797A is reached can also be determined using the flight test data. For wings level the flight test yawing moment coefficient C_n is plotted versus rudder pedal force coefficient C_{F_r} , as shown in Figure 11.25.

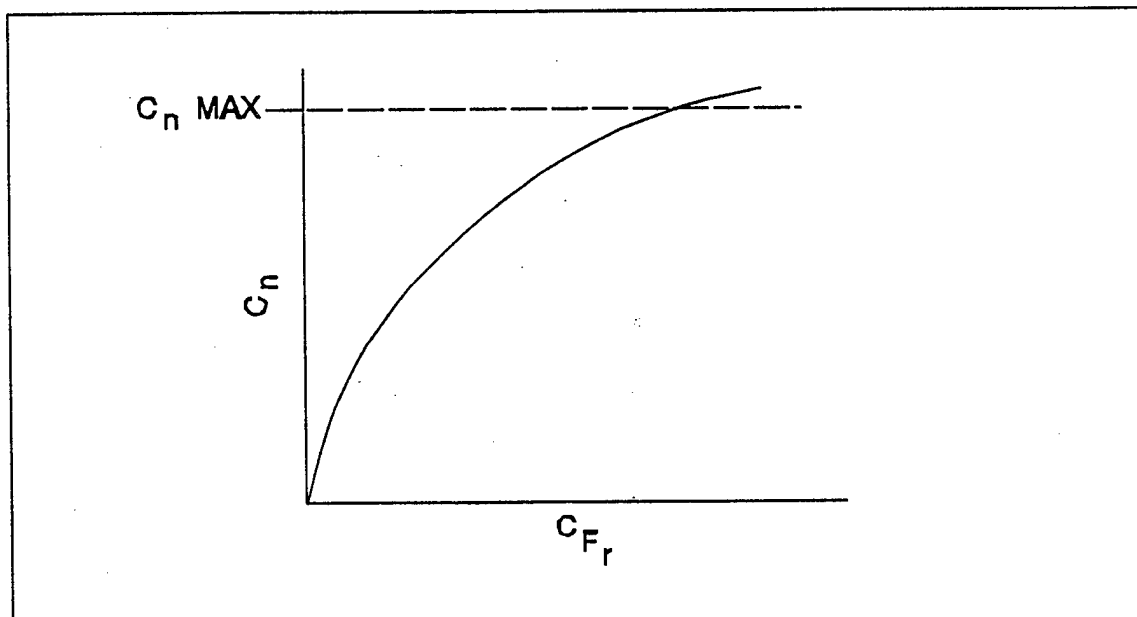

FIGURE 11.25 YAWING MOMENT COEFFICIENT VS RUDDER FORCE COEFFICIENT

For any $C_{n_{max}}$ and $F_r = 180$ lbs., C_{F_r} can be calculated for different altitudes. These points can be plotted and straight lines drawn to the origin as shown in Figure 11.26.

These lines represent lines of constant rudder force equal to 180 pounds. If the altitude line intersects the C_n vs C_{F_r} curve prior to intersecting the maximum $C_{n_{max}}$ line, the 180 pounds rudder force will be reached before maximum rudder deflection. This will be the limiting factor as in the sea level case. If the constant rudder force line intersects the maximum $C_{n_{max}}$ line first, then maximum rudder deflection will occur before 180 pounds rudder force and δ_r becomes the limiting factor.

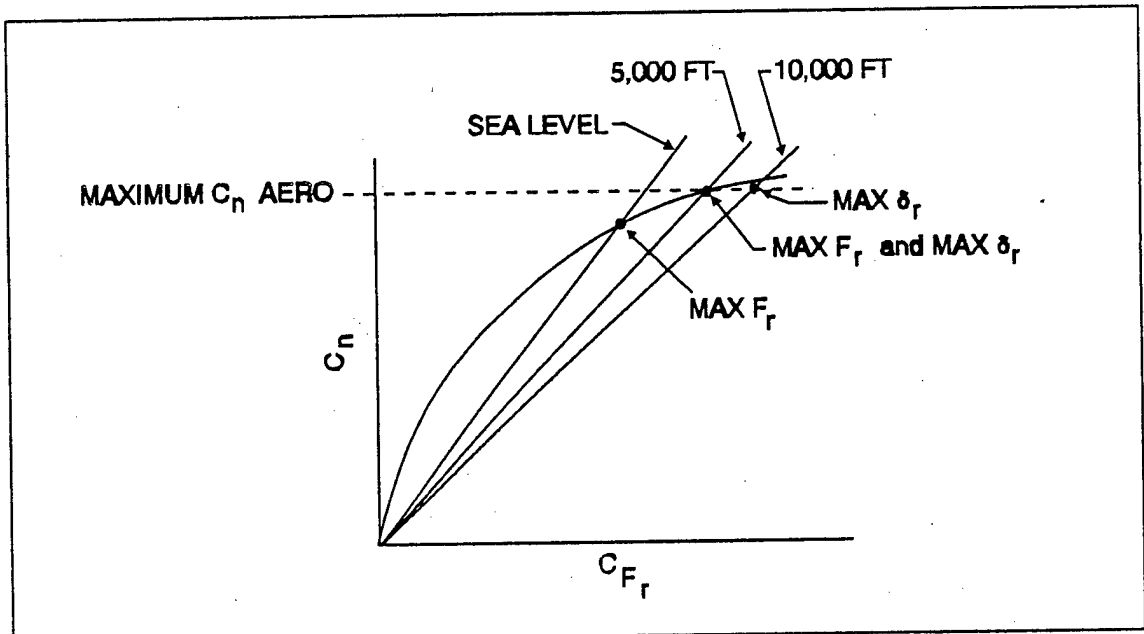

FIGURE 11.26 YAWING MOMENT LIMITED BY RUDDER FORCE

For banked flight, the variation of rudder force coefficient with the banked component of lift can be plotted as in Figure 11.27.

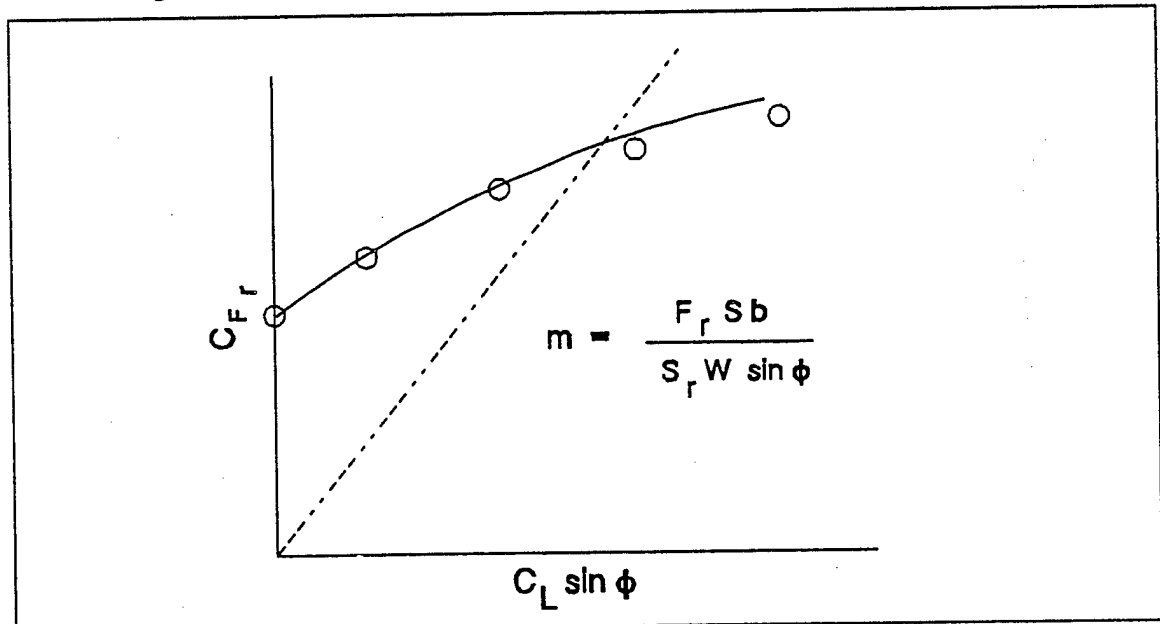

FIGURE 11.27 RUDDER FORCE COEFFICIENT VERSUS BANKED LIFT COEFFICIENT

If we hold gross weight constant, define bank angle equal to 5 degrees and rudder force as 180 lbs, we can compute and plot a line whose slope is:

$$m = \frac{F_r S b}{S_x W \sin \phi} \quad \text{Where:} \quad C_{F_r} = m C_L \sin \phi$$

This defines the maximum rudder deflection allowable for this condition. Using this maximum rudder deflection we have a "modified" maximum aerodynamic yawing moment. This modified yawing moment can be superimposed on either "Weight Effects", Figure 11.23 or "Altitude Effects", Figure 11.24. The modified yawing moment is shown for a constant gross weight as a dashed line in Figure 11.28.

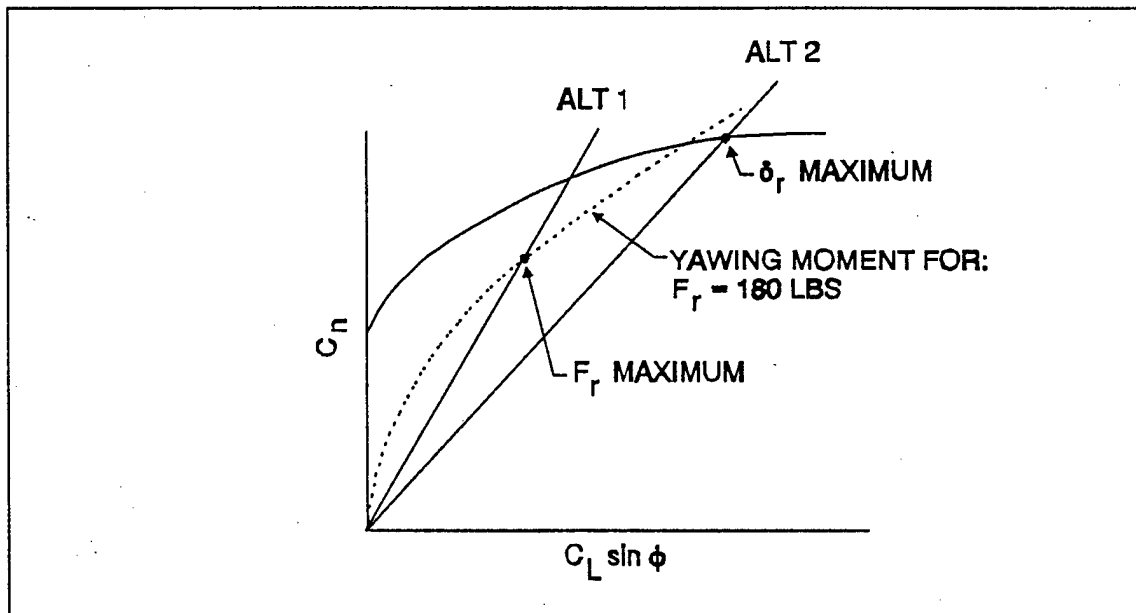

FIGURE 11.28 BANKED YAWING MOMENT LIMITED BY RUDDER FORCE

As in the wings level data, if the modified yawing moment coefficient line (dashed) intersects the altitude line first, the minimum control speed is rudder force limited.

11.6.4 Secondary Method of Data Analysis

The previous discussion of engine-out data analysis is limited in that an accurate thrust deck is needed to calculate values of $C_{n_{min}}$. If a thrust deck is not available, another method of analyzing the data must be used. This method is used to approximate sea level V_{mca} based on test day conditions.

With the aircraft in the specified configuration, and with the critical engine failed, a series of stabilized points are recorded at decreasing speeds. A plot of the control forces and deflections versus airspeed is made to determine the minimum control speed and Mil Standard compliance. For a directional control limited aircraft this is typically rudder force and deflection as depicted in Figure 11.29.

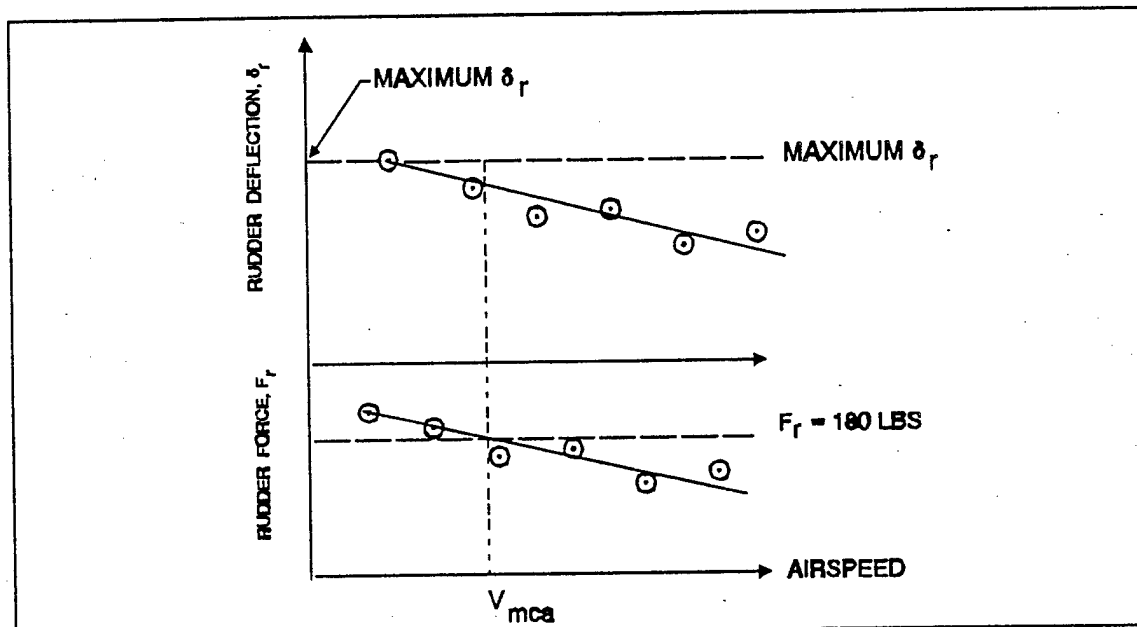

FIGURE 11.29 RUDDER FORCE AND DEFLECTION VERSUS AIRSPEED

The test must be accomplished at more than one altitude, including one as low as is safely possible, to provide accurate extrapolation to sea level as shown in Figure 11.30. Note that the air minimum control speed increases at lower altitude due to increased engine thrust. This method is limited to predicting approximate altitude effects on test day data.

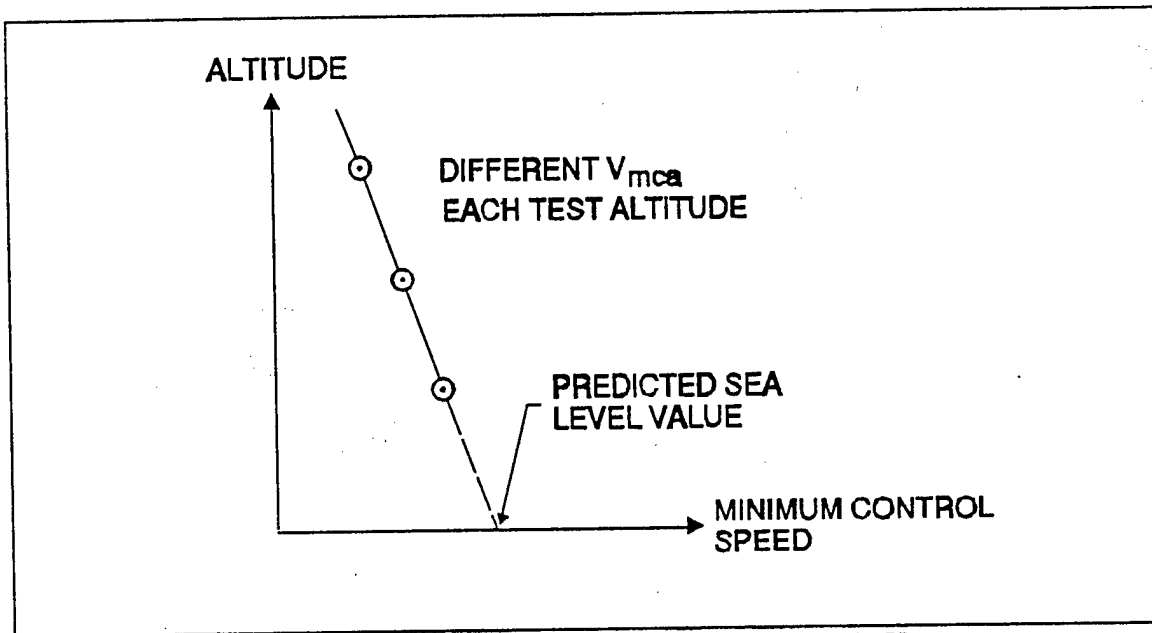

FIGURE 11.30 PREDICTED SEA LEVEL V_{mca}

11.6.5 Lateral Control Data Analysis

There is no proven non-dimensional technique to generalize minimum control speed data where lateral controllability is the determining factor. An attempt has been made however, to describe an analysis procedure which may be applicable to these aircraft.

On powered-lift or immersed-wing aircraft, very large lift vectors are generated on each wing because of the blowing effect. Under asymmetric power conditions, these large lift vectors result in large rolling moments which can be illustrated by Figure 11.31.

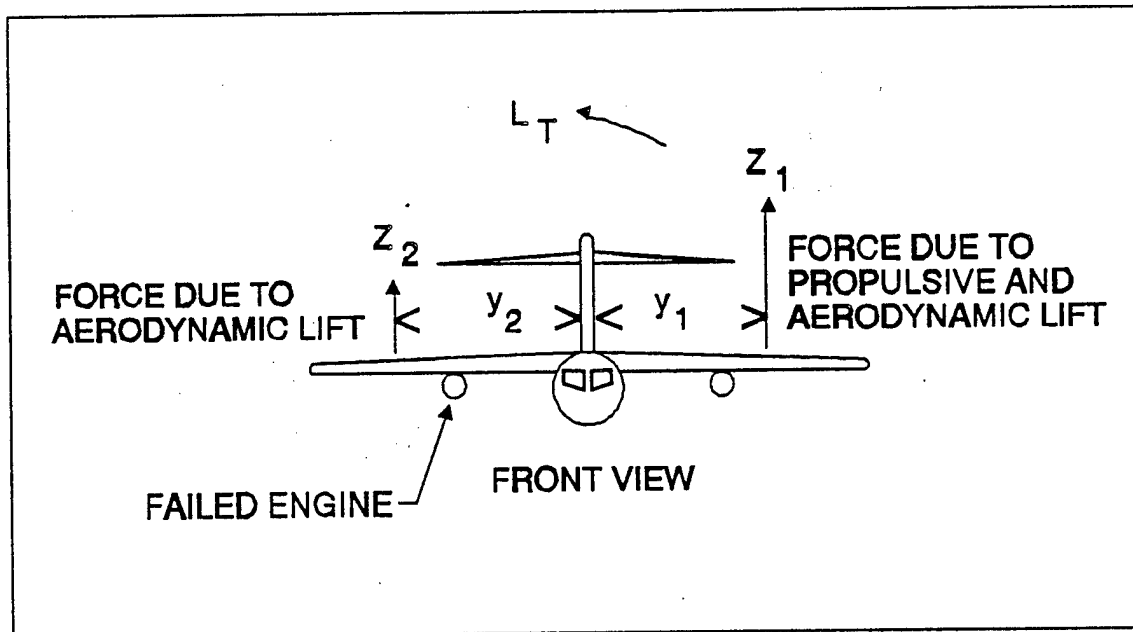

FIGURE 11.31 ROLLING MOMENTS WITH ASYMMETRIC THRUST

The total rolling moment, L_T on the aircraft is

$$L_T = -y_2 Z_2 + y_1 Z_1$$

where:

Z_1 and Z_2 = lift (lbs) due to both propulsive and aerodynamic lift or aerodynamic lift alone.

y_1 and y_2 = distance (ft) from aircraft centerline to lift vectors Z_1 and Z_2 respectively (y_1 and y_2 not necessarily equal).

The non-dimensional thrust rolling moment coefficient is:

$$C_{l_r} = \frac{L_T}{qSb} \quad (11.26)$$

Equation 11.18 now becomes

$$C_{l_r} + C_{l_\beta} \beta + C_{l_{\delta_a}} \delta_a + C_{l_{\delta_r}} \delta_r = 0 \quad (11.27)$$

Equations 11.19 and 11.20 remain the same. If an analysis is made similar to that previously shown for the directional control problem, it can be shown that

$$C_{n_r} + K_5 C_{L_r} = K_6 \delta_a + C_{L_r} \sin \phi \quad (11.28)$$

where K_5 and K_6 are constants assuming that the control and stability derivatives shown in Equations 11.19, 11.20 and 11.27 are zero or constant near the angles of attack and airspeeds at which the lateral minimum control speed will occur.

Unfortunately, the magnitudes and directions of the propulsive lift component of the thrust vector and the yawing moment component of the thrust vector are nearly impossible to determine on a powered-lift aircraft. For a conventional aircraft, engine thrust can be assumed to act along the engine centerline which is usually aligned near the aircraft centerline. On a powered-lift airplane, the thrust vector varies according to angle ϵ as shown in Figure 11.32.

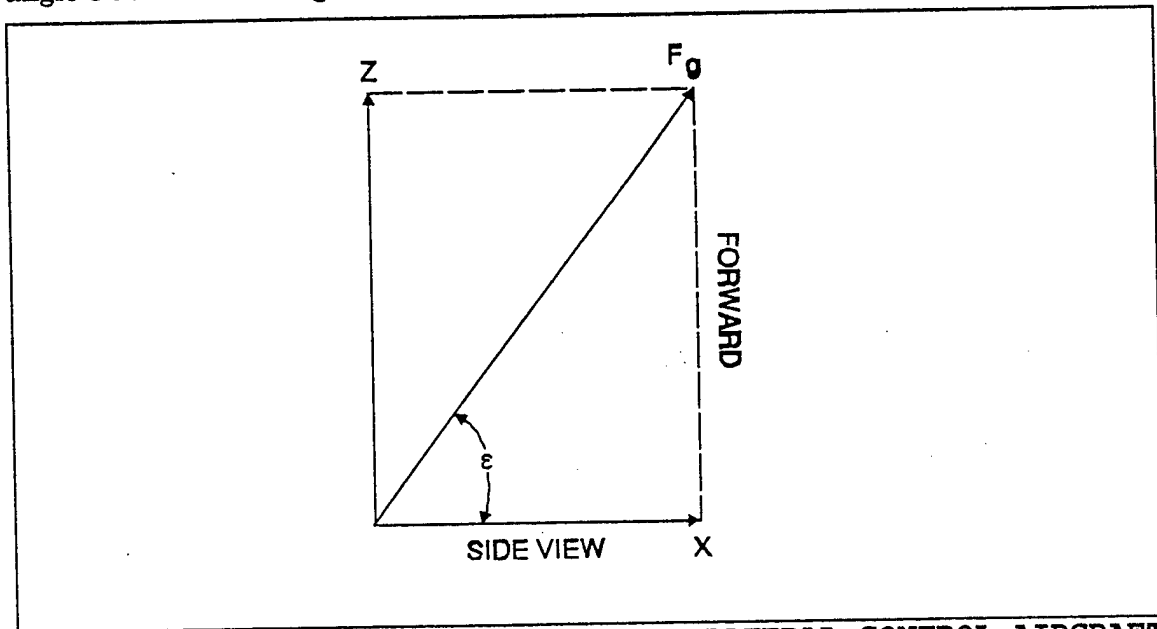

FIGURE 11.32 GROSS THRUST VECTOR - LATERAL CONTROL AIRCRAFT

where

F_g = gross thrust vector, lb

ϵ = angle of downstream jet momentum vector, deg.

Angle ϵ is influenced by the flap angle setting but is not equal to this angle. Therefore, the component forces z and x are nearly impossible to determine. These two vectors are

functions of the gross thrust vector, therefore the following substitution may yield acceptable non-dimensional results

$$C_j = f(\delta_{cw}, C_L \sin \phi) \quad (11.29)$$

where

$$C_j = \text{gross thrust coefficient} = F_g/qS$$

$$\delta_{cw} = \text{lateral control wheel, position, deg.}$$

The substitution of δ_{cw} for δ_a is made because roll control may be a function of spoiler deflection as well as aileron deflection.

The relationship shown in Equation 11.29 may not be correct for some powered-lift airplanes because of variations in the stability and control derivatives near the minimum control speed. However, in lieu of more complicated techniques it may yield satisfactory non-dimensional results.

11.7 APPLICATION OF THE THRUST MOMENT COEFFICIENT TECHNIQUE

11.7.1 IRREVERSIBLE CONTROL SYSTEM

1. Fly various stable points using the "Constant Airspeed" method. Data may be gathered at a variety of altitudes and gross weights. Altitude should be low enough to generate the maximum C_{nT} .
2. Record thrust, ϕ , airspeed, altitude, OAT, gross weight, F_R , and δ_r .
3. For all stable points compute:
 - a. $C_L \sin \phi = W \sin \phi / qS$
 - b. $C_{nT} = F_n / qSb$, where F_n comes from engine specifications.
4. Plot all stable points on a graph of C_n vs $C_L \sin \phi$ as shown in Figure 11.33.

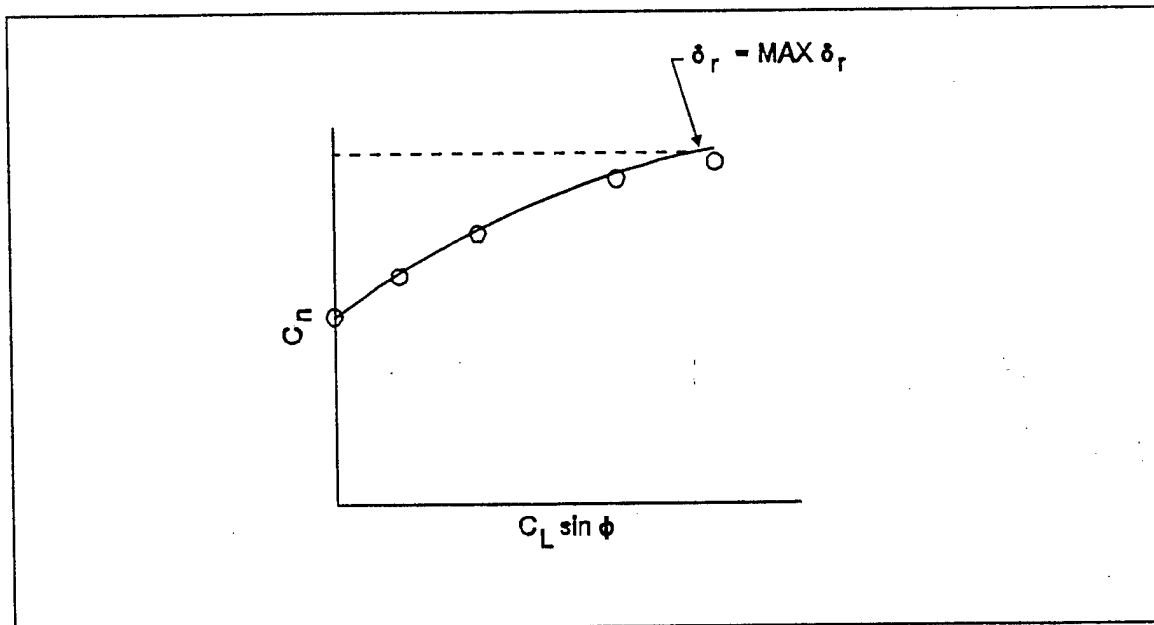

FIGURE 11.33 YAWING MOMENT COEFFICIENT VERSUS BANKED LIFT COEFFICIENT

5. To determine V_{mca} for a conditions of interest, assume an airspeed, altitude, temperature, gross weight, and bank angle (usually 5 degrees). These conditions will define lines which intercepts unique values on the C_n and $C_L \sin \phi$ plot.
6. We define the slope of the line as:

$$m = \frac{F_n l}{b W \sin \phi}$$

7. To get m , use the assumed airspeed, altitude and temperature. Go to engine specification and get thrust. Use the assumed gross weight and bank angle. Now plot a straight line for this assumed case as in Figure 11.34.

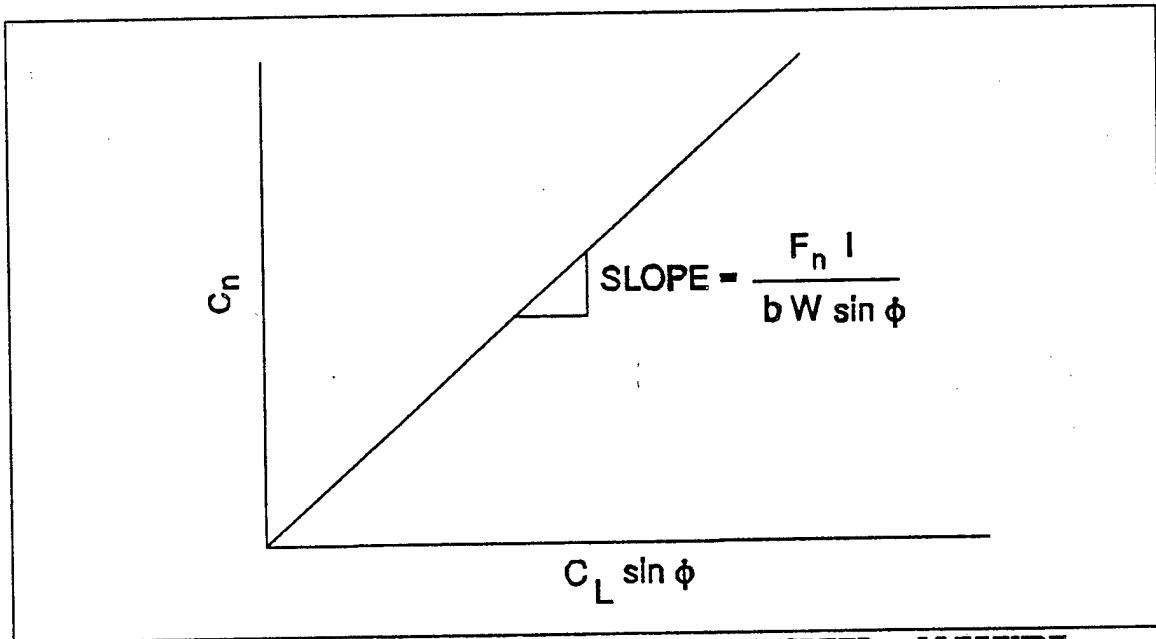

FIGURE 11.34 A LINE OF CONSTANT AIRSPEED, ALTITUDE AND GROSS WEIGHT

8. Compute slopes for other weights at the same altitude and bank angle, and plot them as in Figure 11.35.

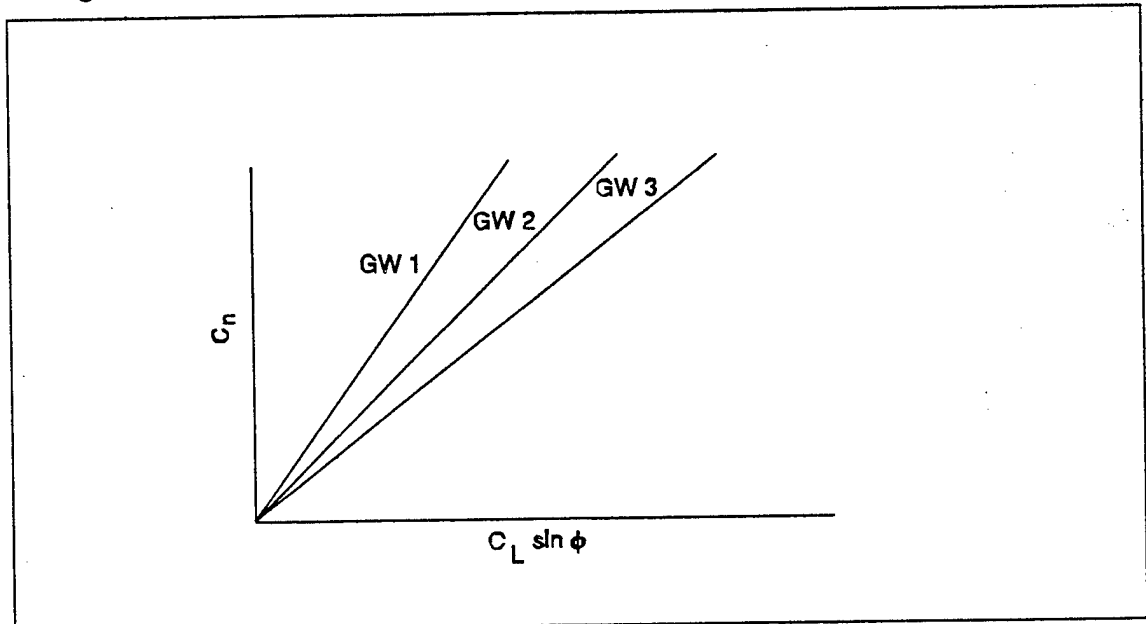

FIGURE 11.35 LINES OF CONSTANT GROSS WEIGHT

9. Figure 11.36 shows an overlay of the generalized C_n vs $C_L \sin \phi$ faired curve with the gross weight lines from step 9.

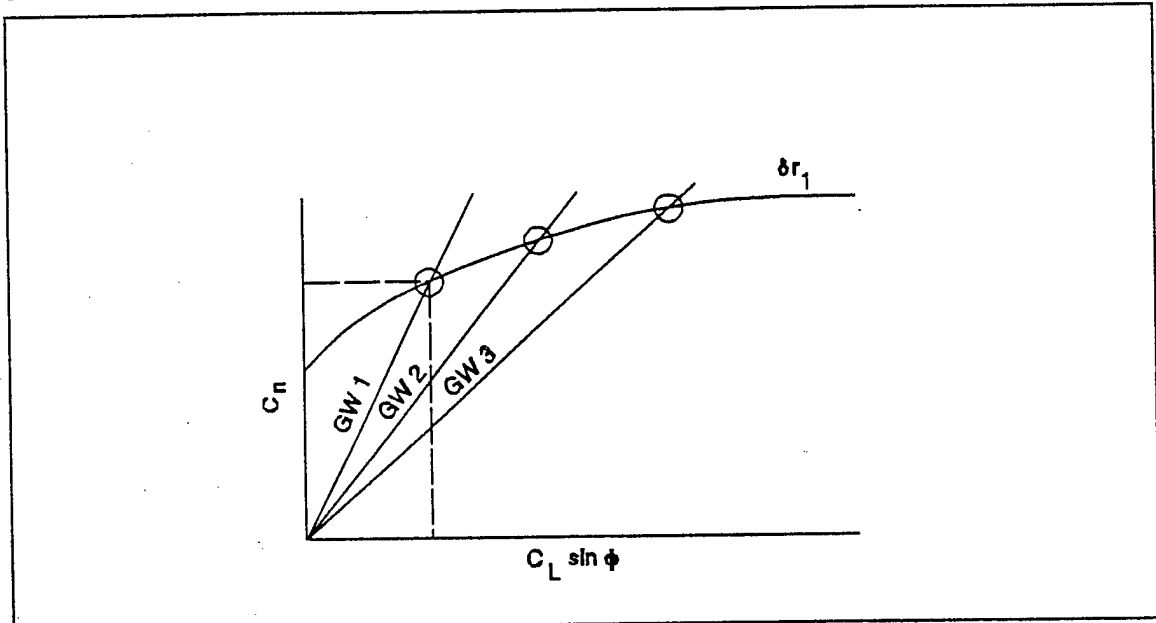

FIGURE 11.36 YAWING MOMENT COEFFICIENT VERSUS BANKED LIFT COEFFICIENT - LINES OF CONSTANT GROSS WEIGHT

The intersections form unique dynamic pressure solutions for a full asymmetric thrust stable point at the gross weight, bank angle and altitude specified.

10. To read V_{mca} for some weight.
 - a. Read C_n at the intersection.
 - b. Go to the engine specifications and read directly the V_c that produces that C_{nT} for the altitude of interest.
 - c. That V_c is V_{mca} for the gross weight, bank angle and altitude selected.

11. By this method, done repeatedly for the whole spectrum of gross weights, a composite plot can be made of any altitude showing V_{mca} as a function of gross weight.

11.7.2 REVERSIBLE CONTROL SYSTEM

1. In reversible system we must determine where rudder deflection is limited by a allowable rudder force in defining V_{mca} . As with the irreversible system, engine specifications for installed net thrust for all altitudes and airspeeds of interest is required.
2. Fly a large number of stable points at various altitudes using the "Varying Airspeed" method to gather data. Record data from wings levels and a variety of bank angles.
3. Record thrust, ϕ , airspeed, altitude, OAT, gross weight, F_R , and δ_r .

4. From engine specification read net thrust.
5. For all stable points compute:
 - a. Yawing moment coefficient, $C_{n_r} = F_n l / qSb$
 - b. Rudder force coefficient, $C_{F_r} = F_r / qS_r$
 - c. Banked lift coefficient, $C_L \sin\phi = W \sin\phi / qSb$
6. Plot C_n versus δ_r . Note the yawing moment coefficient that corresponds to full rudder for wings level as in Figure 11.37.

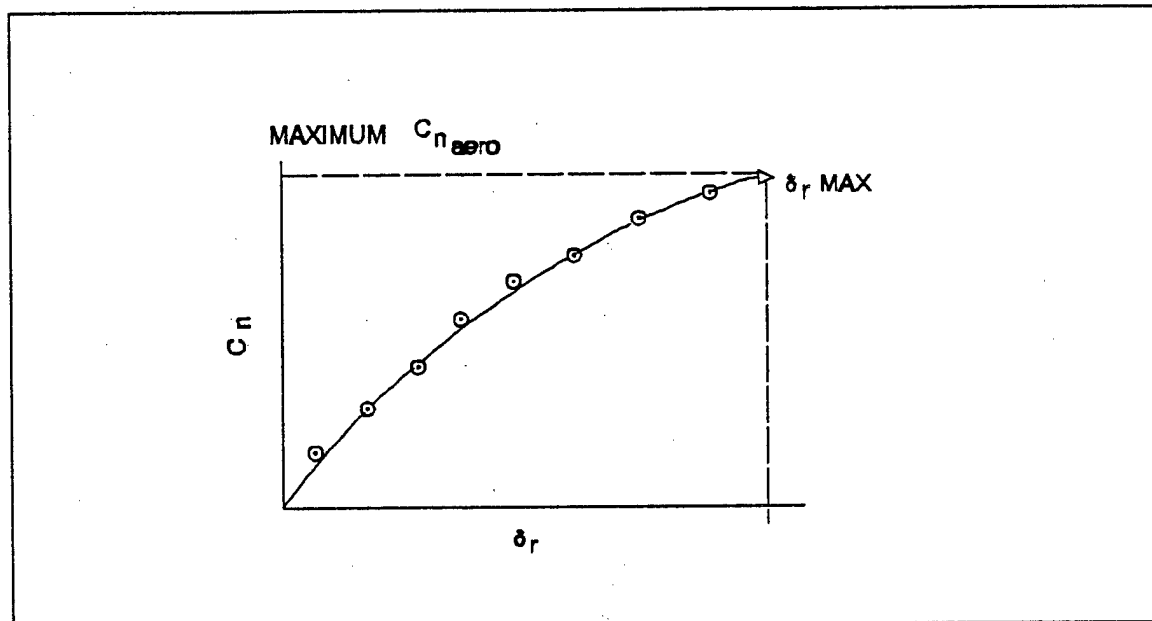

FIGURE 11.37 YAWING MOMENT COEFFICIENT VERSUS RUDDER DEFLECTION

7. Plot $C_{n_r} = F_n l / qSb$ versus $C_{F_r} = F_r / qS_r$ and mark with the $C_{n_{max}}$ maximum from Step 6.
8. We must look at the yawing moment coefficient and rudder force coefficient at a variety of altitudes and gross weights.
 - a. Select an altitude of interest.
 - b. For that altitude select a value of C_n below $C_{n_{max}}$ max. (less than full rudder deflection).
 - c. Go to the engine thrust characteristics for that altitude to determine the V_c for the full asymmetric power C_{n_r} that balances C_n the you selected.
 - d. Assume $F_r = 180$ lbs, the maximum allowable by Mil Standard.

- e. From the chosen altitude and the V_c from step "c" compute C_{F_r} .

$$C_{F_r} = \frac{180}{qS_r}$$

- f. Plot the point on a C_{n_r} vs C_{F_r} plot. Draw a straight line from it to the origin.

- g. Repeat this for each altitude of interest, "ALT 1" through "ALT 3" in Figure 11.38.

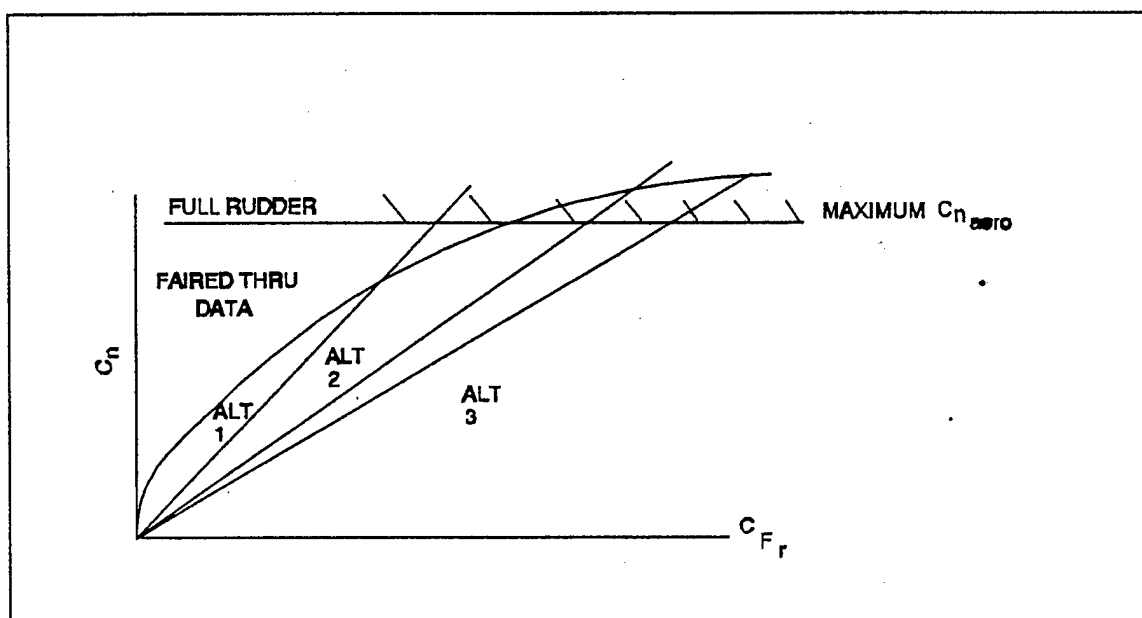

FIGURE 11.38 YAWING MOMENT COEFFICIENT VERSUS RUDDER FORCE COEFFICIENT

- h. The intersection of the altitude lines and the faired line through data points determines the V_{mca} and limiting factor, either force limit or full rudder as in Figure 11.39.

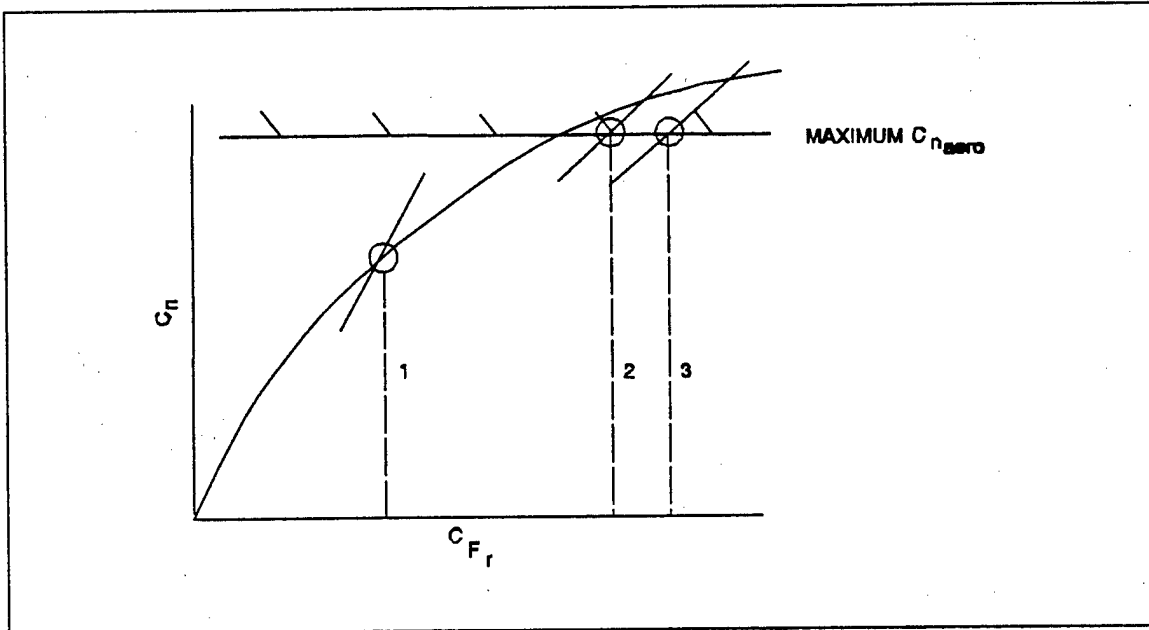

FIGURE 11.39 YAWING MOMENT COEFFICIENT VERSUS RUDDER FORCE COEFFICIENT

9. Now we must again analyze the effects of bank angle. Plot the variation of C_{F_r} with $C_L \sin \phi$ as in Figure 11.40.

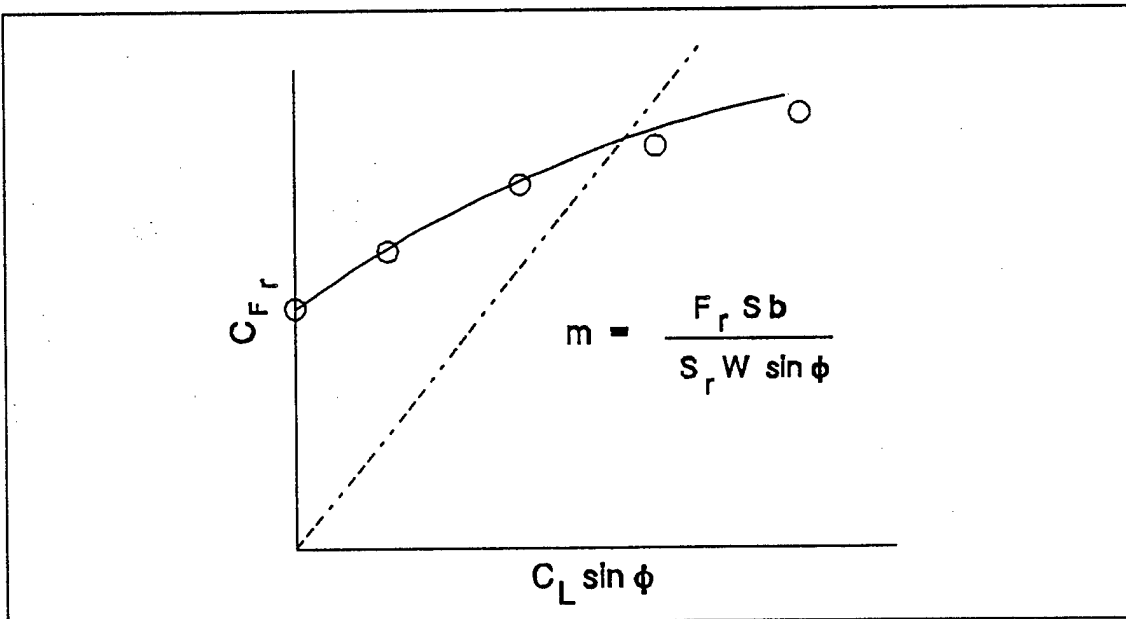

FIGURE 11.40 RUDDER FORCE COEFFICIENT VERSUS BANK LIFT COEFFICIENT

a. For a constant gross weight, a bank angle equal to 5 degrees and 180 pounds of rudder force we can draw a line from the origin whose slope is:

$$m = \frac{F_r S b}{S_r W \sin \phi}$$

b. The intersection of this line with our plot defines a unique $C_{n_{max}}$ and a maximum rudder deflection allowable for the condition.

c. Use this maximum rudder deflection we have a "modified" maximum aerodynamic yawing moment. Plot this modified yawing moment versus banked lift coefficient to determine altitude effects. The modified yawing moment is shown for a constant gross weight as a dashed line in Figure 11.41.

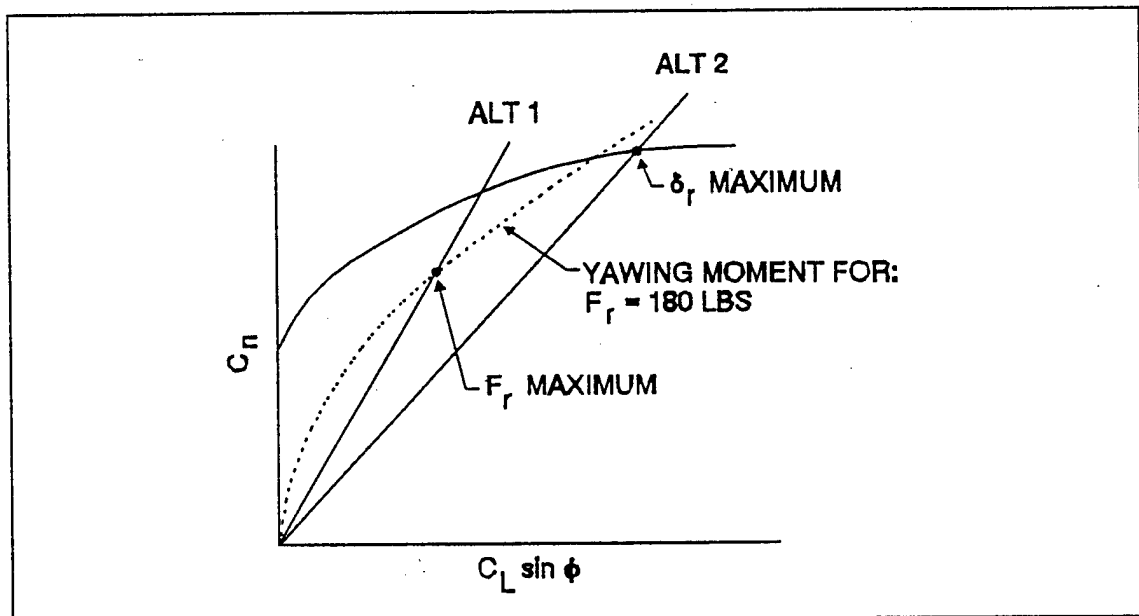

FIGURE 11.41 BANKED YAWING MOMENT LIMITED BY RUDDER FORCE

10. To get V_{mca} for each altitude for which you plotted an altitude line:
 - a. Select the C_{F_r} from the intersection of altitude line and faired line.
 - b. Select the $C_{n_{max}}$ from the intersection of altitude line and faired line.
11. Go to engine specification and read directly the V_C that produces C_{n_r} at the altitude of interest. This is V_{mca} .
12. As with the irreversible system, a composite plot can now be made to show V_{mca} at any altitude, as a function of gross weight.

11.8 DEFINITIONS

ENGINE-OUT DEFINITIONS
PERFORMANCE

V_1	Decision speed. The minimum indicated speed at which an engine failure can be experienced and the takeoff safely continued. The takeoff is committed after passing V_1 . Safe abort is possible prior to reaching this speed V_1 . Guaranteed V_{CEF} and V_{MCG} . It may not exceed V_{REF} , V_{MB} or V_{TO} .
V_1 (FAA)	Same as V_{MCG} but must be shown by means of primary aerodynamic controls alone. Aircraft must also be able to stop in the remaining runway from this speed in case of abort.
V_2 (FAA)	The calibrated airspeed which will provide the required climb gradient (different for props and jets) after liftoff. V_2 must be achieved by 35 feet above the takeoff surface. Must be achieved by end of runway + end of clearway. Clearway can not exceed 1/2 runway.
V_{CEFS}	Critical engine failure speed. The speed to which an engine can accelerate, lose an engine, and then either continue the takeoff or stop in the same total runway distance.
V_{GO}	Go speed. The speed at which the pilot is committed to the takeoff (same as V_1).
V_{LOF} (FAA)	The calibrated airspeed at which the aircraft first becomes airborne.
V_{MB}	Maximum braking speed. The maximum speed to which an aircraft may be accelerated and stopped in the remaining runway using maximum braking.
V_{MIN} CONTINUE	Continuation speed. Minimum speed at which an engine may fail and the aircraft can still accelerate and get airborne in the exact amount of remaining runway.

V_{MU} (FAA)	Minimum unstick speed. The calibrated speed at and above which the airplane can safely lift off the ground and continue the takeoff.
V_{MSES}	The calibrated airspeed which will provide an acceptable rate of climb after loss of an engine after lift off. This airspeed may be significantly higher than V_{MCA} .
V_R (FAA)	The speed that, if the airplane is rotated at its maximum practicable rate, will result in a V_{LOF} of not less than 110% V_{MU} in the all-engines-inoperative condition or less than 105% of V_{MU} in the one-engine-inoperative condition. This speed must also allow reaching V_2 before reaching 35 feet above the takeoff surface.
V_{REF}	Refusal speed. The maximum speed to which an aircraft may be accelerated and stopped in the remaining runway using maximum braking.
V_{ROT}	Rotation speed. The speed at which rotation to the takeoff attitude is initiated.
V_{TO}	Rotation speed. The speed at which rotation to the takeoff attitude is initiated.
CFL	Critical Field Length. The total length of runway required to accelerate on all engines to V_{CEF} experience an engine failure, then continue to takeoff or stop.
RA	Runway available. Actual runway length less the aircraft line-up distance.

ENGINE-OUT DEFINITIONS
CONTROL

V_{MCA}	Minimum control speed (flight). The minimum flight speed at which aircraft control is possible with the critical engine(s) inoperative.
V_{MCG}	Minimum control speed (ground). The lowest speed on the takeoff run at which directional control can be maintained with the critical engine failed and the other engines operating at takeoff power.

BIBLIOGRAPHY

1. Bradfield, Edward. Procedures and Analysis Techniques for Determining Static Air Minimum Control Speeds. 1976.
2. "EC-18B USAF S/N 8-10891 Aero-Evaluation Memo-0026: Determination of V_{MCA} ." 19 July 1986.
3. MIL-STD-1793. 13 December 1985.
4. MIL-STD-1797A. 30 January 1990.
5. Flight Test Guide for Certification of Transport Aircraft, Federal Aviation Administration, 9 April, 1986.