

0025

Control Design for Evolutionary Structural Systems

Prepared by

Dr. Andrew J. Kurdila
Principal Investigator

Dr. Thomas Strganac
Co-Principal Investigator

Center for Mechanics and Control
Department of Aerospace Engineering
Texas A&M University
College Station, Texas 77843-3141

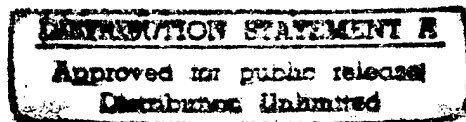

Final Report under contract No. F49620-92-J-0450

Prepared for

U.S. Air Force Office of Scientific Research

March, 1994

19970117 084

REPORT DOCUMENTATION PAGE			Form Approved OMB No. 0704-0188	
Public reporting burden for this collection of information is estimated to average 1 hour per response, including the time for reviewing instructions, searching existing data sources, gathering and maintaining the data needed, and completing and reviewing this collection of information. Send comments regarding this burden estimate or any other aspect of this collection of information, including suggestions for reducing this burden, to Washington Headquarters Service, Directorate for Information Operations and Reports, 1215 Jefferson Davis Highway, Suite 1204, Arlington, VA 22202-4302, and to the Office of Management and Budget, Paperwork Reduction Project (0704-0188), Washington, DC 20503.				
1. AGENCY USE ONLY (Leave blank)	2. REPORT DATE 31 Mar 1994	3. REPORT TYPE AND DATES COVERED Final, 1 Sep 92 - 31 Aug 93		
4. TITLE AND SUBTITLE Control Design for Evolutionary Structural Systems			5. FUNDING NUMBERS F49620-92-J-0450	
6. AUTHOR(S) Kurdila, Andrew J. and Strganac Thomas				
7. PERFORMING ORGANIZATION NAME(S) AND ADDRESS(ES) Department of Aerospace Engineering Texas A & M University College Station, TX 77843-3141			8. PERFORMING ORGANIZATION REPORT NUMBER	
9. SPONSORING/MONITORING AGENCY NAME(S) AND ADDRESS(ES) AFOSR/NA 110 Duncan Ave, Suite B115 Bolling AFB, DC 30332-0001			10. SPONSORING/MONITORING AGENCY REPORT NUMBER	
11. SUPPLEMENTARY NOTES				
12a. DISTRIBUTION/AVAILABILITY STATEMENT Approved for Public Release; Distribution is Unlimited			12b. DISTRIBUTION CODE	
13. ABSTRACT (Maximum 200 words) This report summarizes the result of a one year effort. During this period, we have: (1) extended the infinite dimensional, game theoretical control strategy to account for structured uncertainty arising in (A) the control influence operator associated with piezoceramic actuators, and (B) constitutive law evolution, and (2) performed a coupled fluid/structure/control analysis that synthesizes the distributed control approach derived in (1) with a flutter induced phenomenological, microcrack model for a panel. The work has also enabled the research team to: (1) develop an experimental wind-tunnel facility designed expressed for the study of the onset of flutter, nonlinear aeroelasticity and verification of the control theories (derived in this research), and (2) derive multisolution-based analysis methods for the investigation of the onset of flutter in the experimental facilities.				
14. SUBJECT TERMS Aeroelasticity; Structural Control; Wavelet Applications			15. NUMBER OF PAGES 58	
			16. PRICE CODE	
17. SECURITY CLASSIFICATION OF REPORT Unclassified	18. SECURITY CLASSIFICATION OF THIS PAGE Unclassified	19. SECURITY CLASSIFICATION OF ABSTRACT Unclassified	20. LIMITATION OF ABSTRACT Unlimited	

Control Design for Evolutionary Structural Systems

Prepared by

Dr. Andrew J. Kurdila
Principal Investigator

Dr. Thomas Strganac
Co-Principal Investigator

Center for Mechanics and Control
Department of Aerospace Engineering
Texas A&M University
College Station, Texas 77843-3141

Final Report under contract No. F49620-92-J-0450

Prepared for

U.S. Air Force Office of Scientific Research

March, 1994

Summary

This report summarizes the results of a one year basic research effort under the Air Force Office of Sponsored Research contract No. F49620-92-J-0450

As summarized in our proposal and letter to Dr. Spencer Wu, the stated goal of this research has been

“...During the first year of our research we will derive the analytical model of the aeroservoelastic system to account for the coupled fluid flow/control/structure field equations. Our methodology to accomplish this research goal above will be to integrate

(1) the infinite dimensional, game theoretic control theory for distributed parameter systems developed by [Kurdila] and,

(2) a model of fluid flow / structure interaction as developed by [Strganac].

It is anticipated that we will additionally further identify issues to complement the needs of the research community.”

Our research accomplishments have far exceeded our stated goals for the first year. During this period,

(1) we have extended the infinite dimensional, game theoretic control strategy to account for structured uncertainty arising in the control influence operator associated with piezoceramic actuators,

(2) we have extended the infinite dimensional, game theoretic control strategy to account for structured uncertainty arising in constitutive law evolution,

(3) we have derived a coupled fluid/structure/control analysis that synthesizes the distributed control approach derived in (i) and (ii) above with a flutter induced phenomenological, microcrack model for a panel.

Our first year of research has not only accomplished the stated goals of the proposal, but has also enabled the research team

(1) to develop an experimental wind-tunnel facility designed expressly for the study of the onset of flutter, nonlinear aeroelasticity and verification of the control theories derived in this research;

(2) to derive multiresolution-based analysis methods for the investigation of the onset of flutter in our experimental facilities;

(1) Derivation of Distributed Control Analysis for Fluid/Structure/Control Interaction

During pilot studies conducted under AFOSR contract F49620-92-J-0450, it has been demonstrated that wavelet-Galerkin methods are directly applicable to a wide class of fluid-structure-control interaction problems of relevance to the Air Force. For examples, figures (3.1.1-1) through (3.1.1-5) are attracted extracted from [KKKS] and illustrate that wavelet-Galerkin methods provide excellent representations of sharp edge effects commonly introduced in modelling piezoceramic actuators. Figure (3.1.1-1) depicts the control influence function represented via a Daubechies order 3 wavelet, and the structured uncertainty function employed to represent edge delamination. Figure (3.1.1-2) illustrates disturbance attenuation in a closed-loop response derived using an infinite dimensionel, game-theoretic control design employing a wavelet basis. Figures (3.1.1-3) and (3.1.1-4) illustrate the improved performance of the game theoretic control, in comparison to linear quadratic regulation. Both control simulations are conducted using the wavelet-Galerkin method. Figure (3.1.1-5) illustrates the profound difference between finite and "infinite dimensional" stability margins calculated when employing the wavelet-Galerkin method.

During the investigation above, and in other studies supported by AFOSR contract F49620-92-J-0450, it has become clear that a central issue in employing multiresolution analysis in theoretical mechanics and dynamics is the derivation of general and efficient techniques for treating boundary conditions. Three different approaches have been derived under AFOSR contract F49620-92-J-0450, and will be presented at the 35th Structures, Structural Dynamics and Materials Conference in April, 1994. These three methods are based upon the use of

- (i) boundary integral equations,
- (ii) numerical boundary measures, and
- (iii) wavelet-based finite elements

to derive wavelet-based representations of fluid/structure/control interaction problems. For example, figure (3.1-6) illustrates the use of boundary integral equations to represent fluid flow around a two dimensional airfoil using multiresolution analysis methods. These results are extracted from [Ku1] and have been carried out under AFOSR contract F49620-92-J-0450.

An alternative means of representing coupled fluid-structure interaction problems is presented in [KKKS] and [KKW], wherein numerical boundary measures are utilized to enable the solution of fluid-structure interaction problems on general domains. Figures (3.1.1-7) and (3.1.1-8) enable the visualization of a simple airfoil and its associated numerical boundary measure. Figures (3.1.1-9) and (3.1.1-12) illustrate the central conclusion of [KKW].

"It is possible to generate numerically stable boundary measures that retain the nonnegative character of the underlying boundary value problem."

Specifically, this conclusion is apparent from the results of "method 2" in figures (3.1.1-9) through (3.1.1-12). The interested reviewer i referred to [KKW] for a more detailed discussion. Figures (3.1.1-13) through (3.1.1-14) demonstrate that it is also possible to combine *nonlinear dynamical system theory* with computational mechanics to solve multiresolution problems on arbitrary domains. In figure (3.1.1-13), an iterated function system is constructed such that the boundary of interest is its domain of attraction. Figure (3.1.1-14) illustrates the domain embedding solution obtained employing an associated ergodic theory described in [Ku2]. As noted ear-

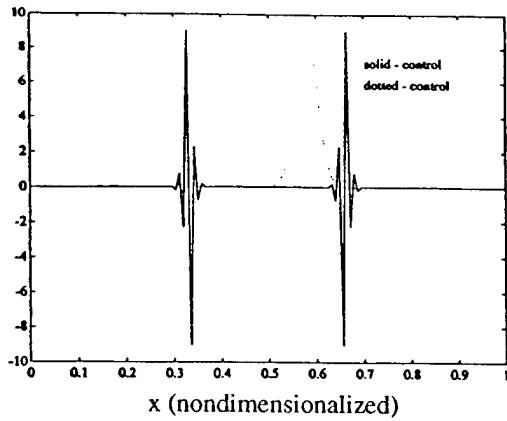

Figure (3.1.1-1) Control Influence and Disturbance

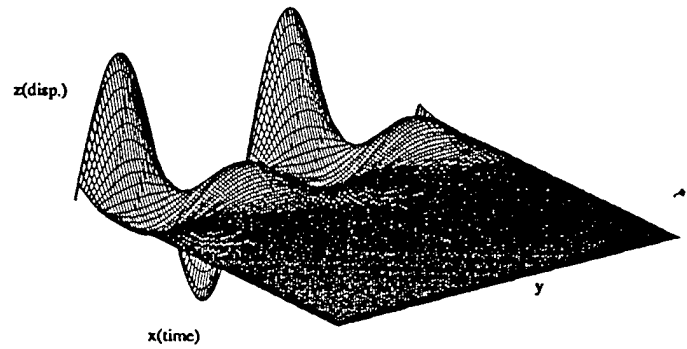

Figure (3.1.1-2) Closed Loop Response to Initial Condition

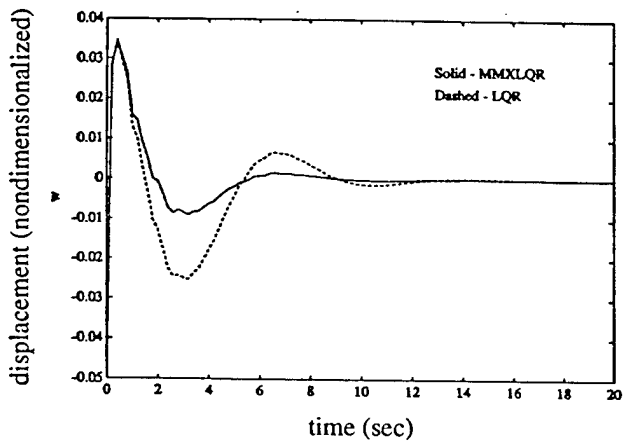

Figure (3.1.1-3) Disturbance Attenuation, Game Theoretic Compared to Linear Quadratic Regulation

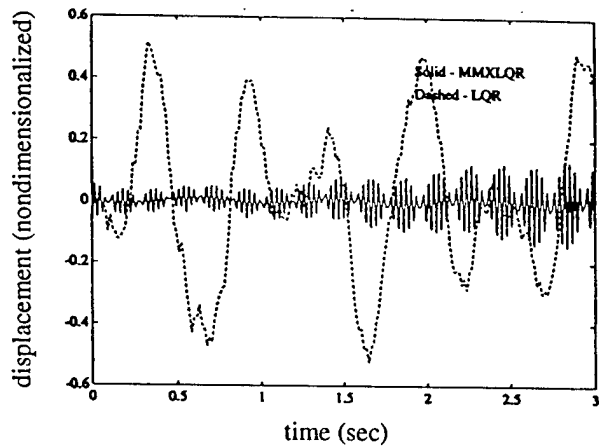

Figure (3.1.1-4) Disturbance Rejection, Game Theoretic Compared to Linear Quadratic Regulation

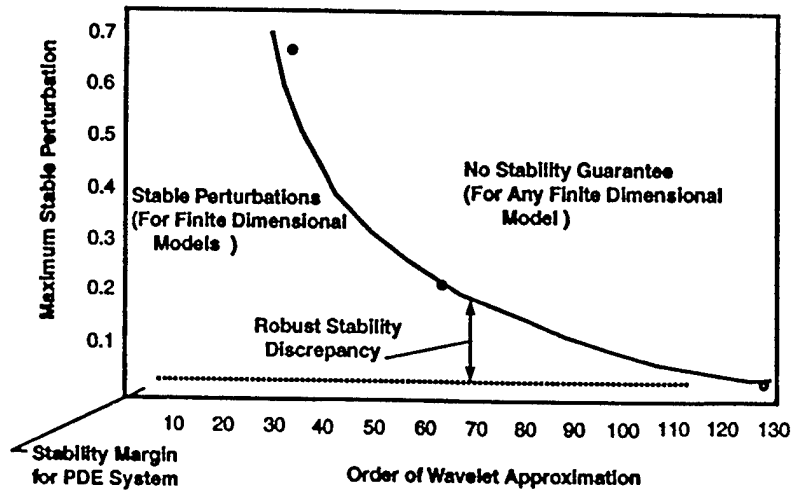

Figure (3.1.1-5) Robust Stability Discrepancy, Finite Dimensional Models Compared to Infinite Dimensional Limit

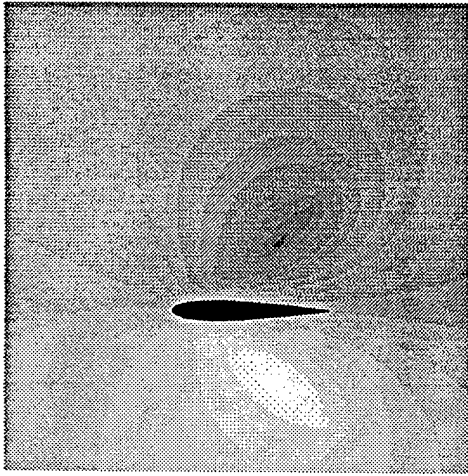

Figure (a) Wavelet Galerkin Solution of Boundary Integral Equation, potential function

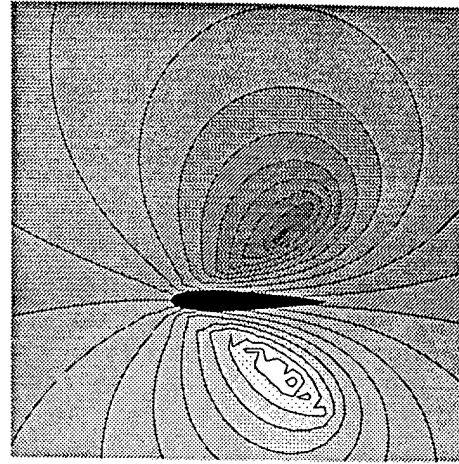

Figure (b) Wavelet Galerkin Solution of Boundary Integral Equation, potential function

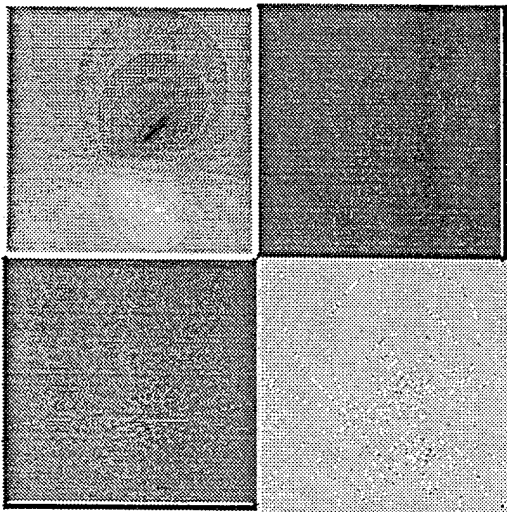

Figure (c) Fast Wavelet Transform of Solution, Level 1 Resolution

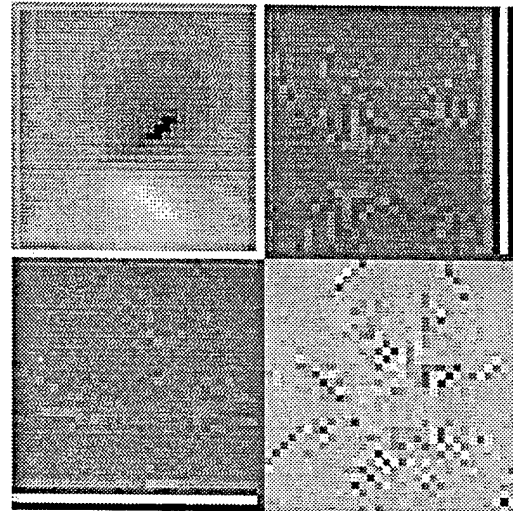

Figure (d) Fast Wavelet Transform of Solution, Level 3 Resolution

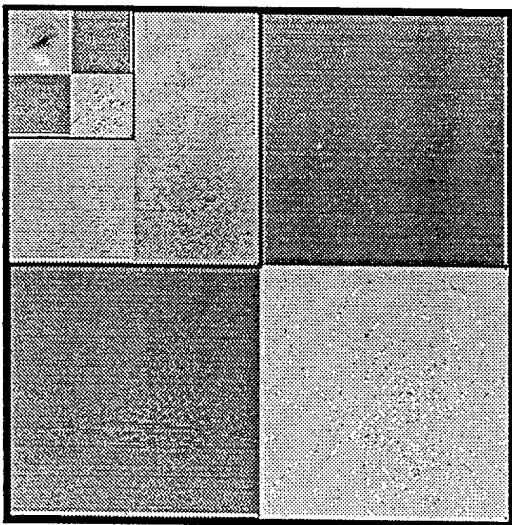

Figure (e) Multiresolution Representation, 3 Levels, Overwritten, Daubechies Order 3

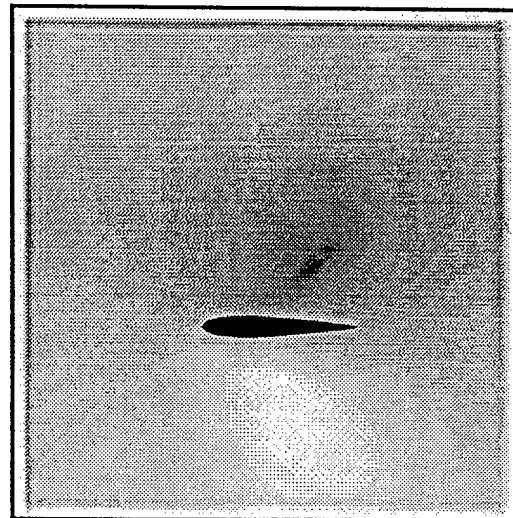

Figure (f) Wavelet Galerkin Solution of Boundary Integral Equation, potential function

Figure (3.1.1-6) Wavelet-Galerkin Solution of Boundary Integral Equations for Flow Past An Airfoil, Multiresolution Representation

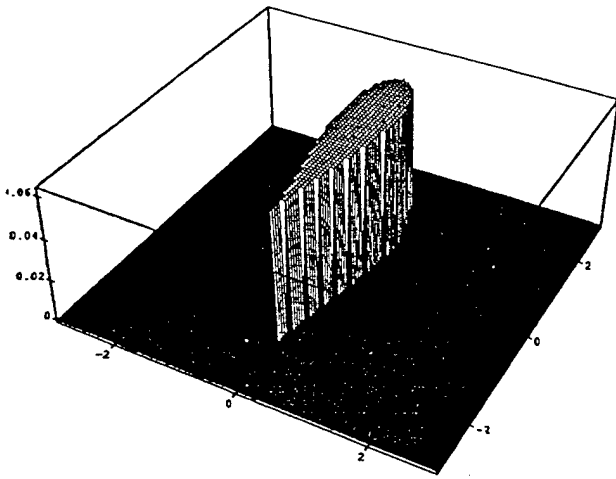

Figure (3.1.1-7) Characteristic Function of Airfoil

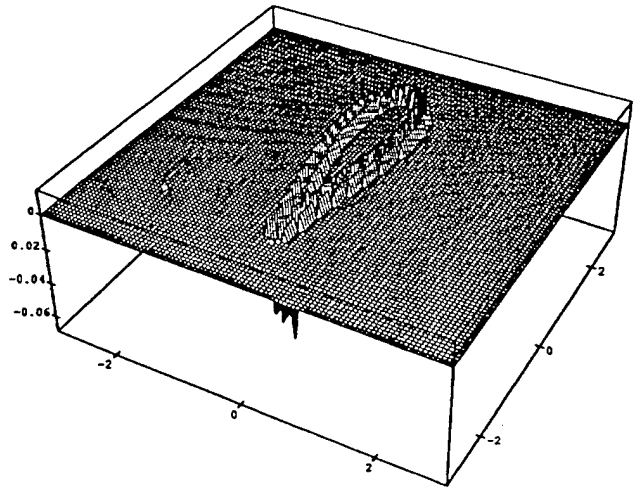

Figure (3.1.1-8) Numerical Boundary Measure for Airfoil

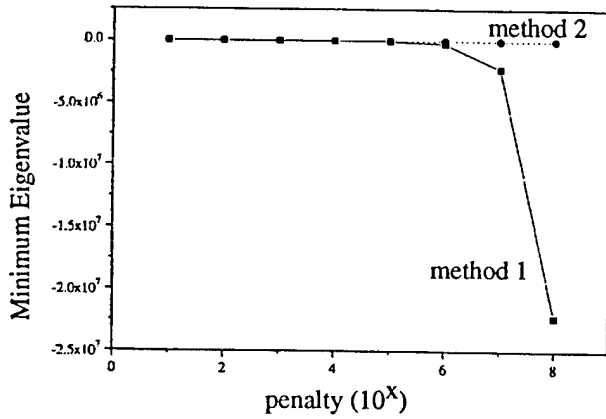

Figure (3.1.1-9) Negative Eigenvalue Magnitude as a Function of Penalty Parameter

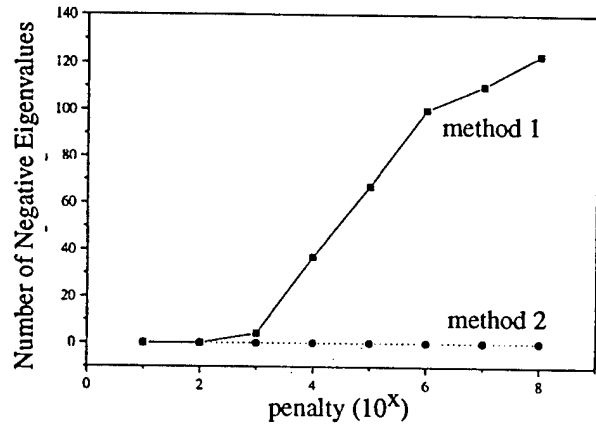

Figure (3.1.1-10) Number of Negative Eigenvalues as a Function of Penalty Parameter

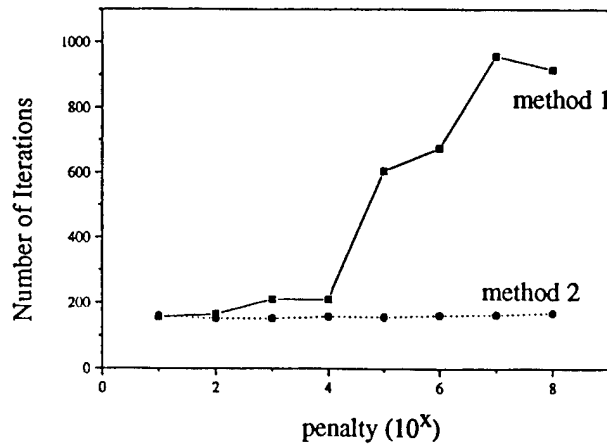
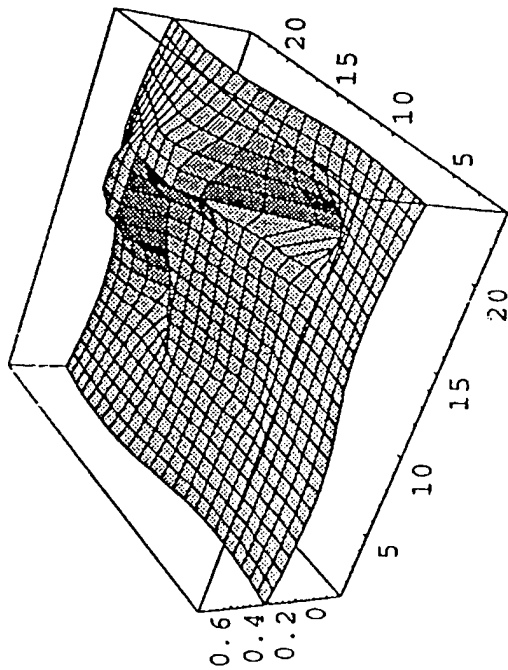
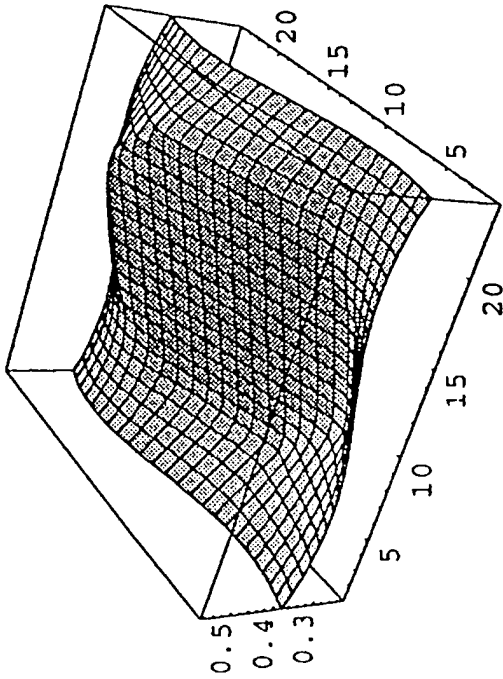

Figure (3.1.1-11) Number of Iterations for Convergence as a Function of Penalty Parameter



Resolution Level 3, $\epsilon=10e-4$



Resolution Level 3, $\epsilon=10e-4$

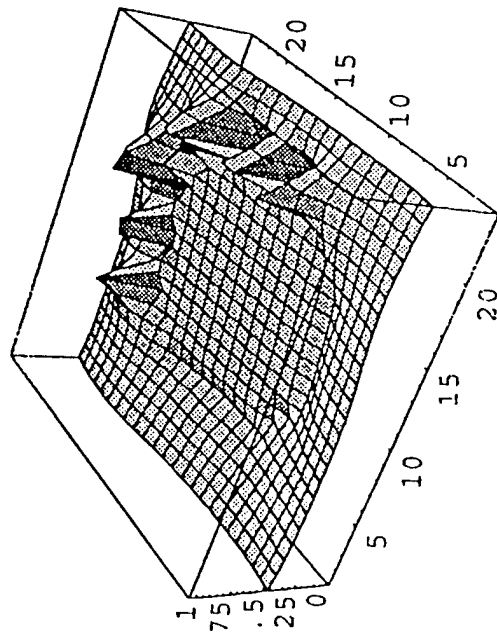

Resolution Level 3, $\epsilon=10e-6$

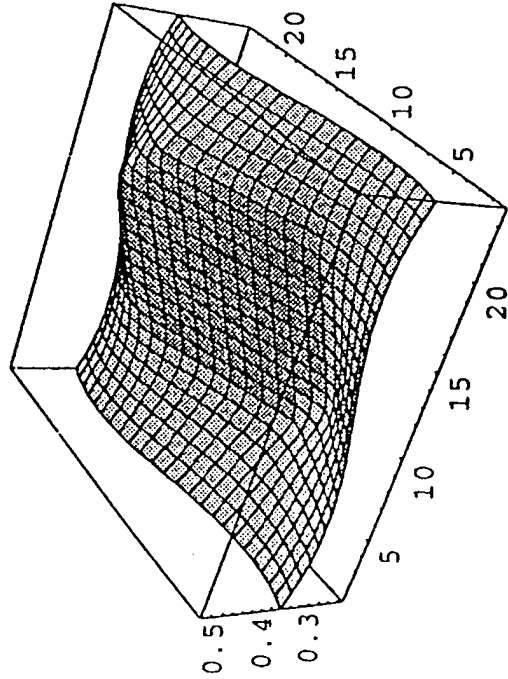

Resolution Level 3, $\epsilon=10e-6$

Figure (3.1.1-12) Smoothness of Domain Embedding, Comparison of Numerical Boundary Measures, Method 1 (right) and Method 2 (left)

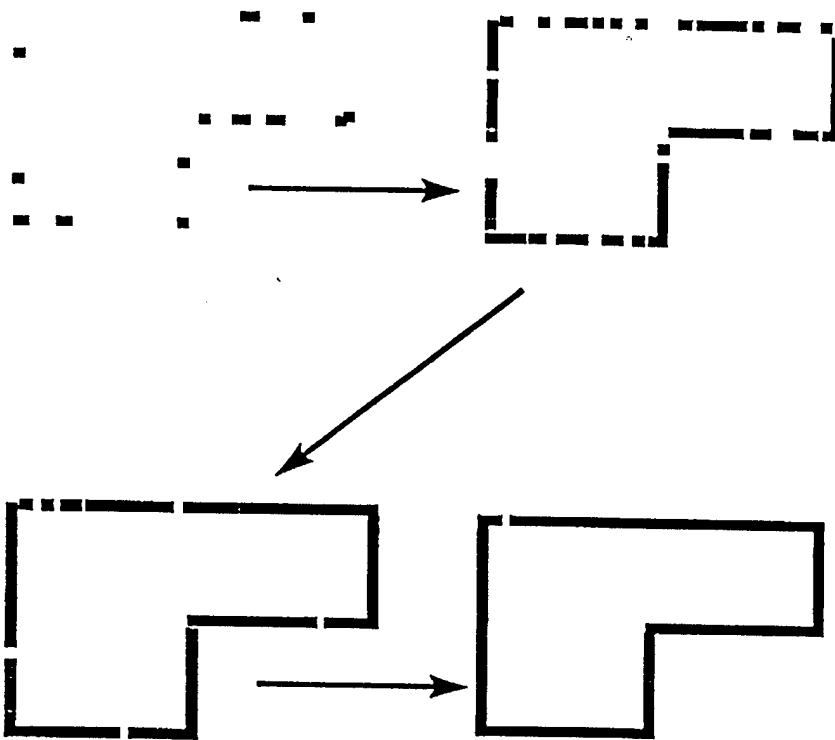

Figure (3.1.1-13) Convergence in Hausdorff Measure of Iterated Function System to Irregular Boundary

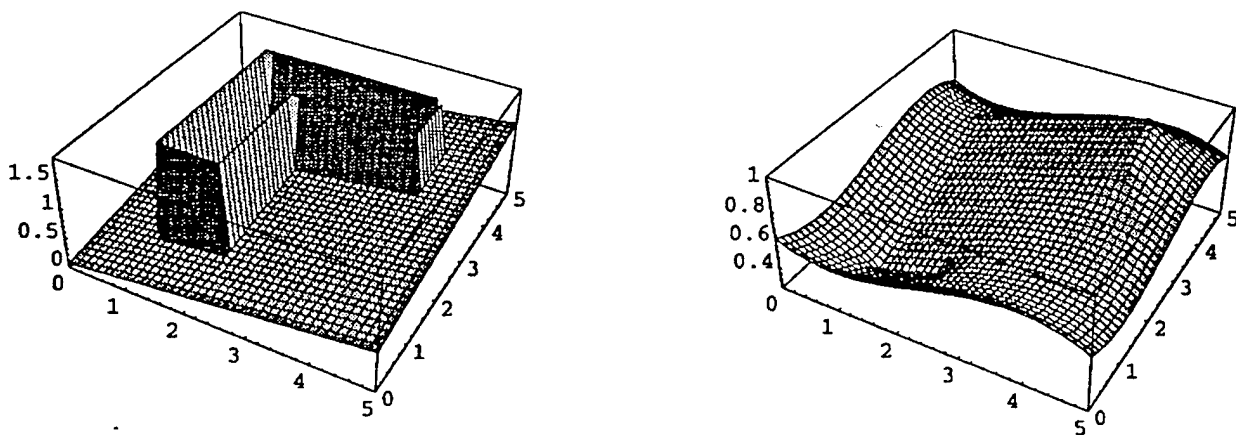

Figure (3.1.1-14) Domain Embedding Solution Employing Markov Chain Associated with Iterated Function System and Ergodicity

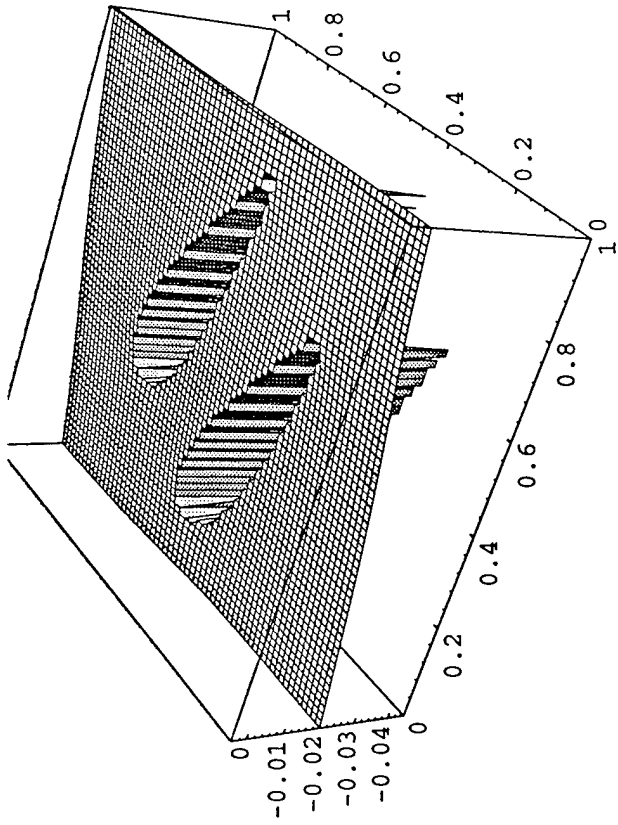

Figure (3.1.1-15) Closely Couple Airfoils, (64x64)
Potential Function in 3D

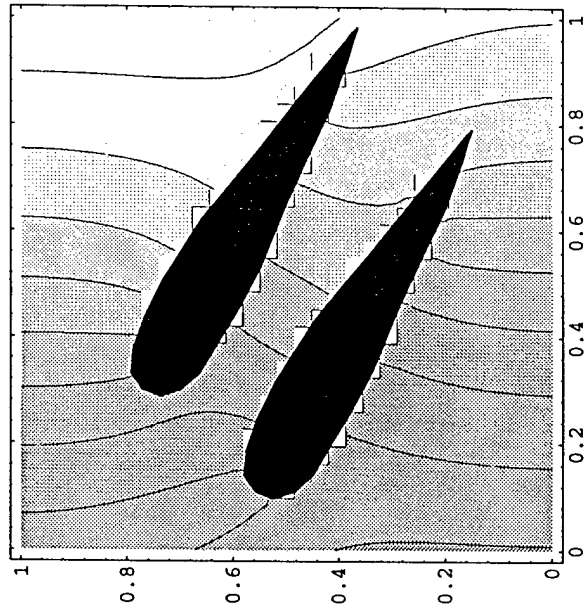

Figure (3.1.1-17) Closely Couple Airfoils, (64x64)
Potential Function Contours

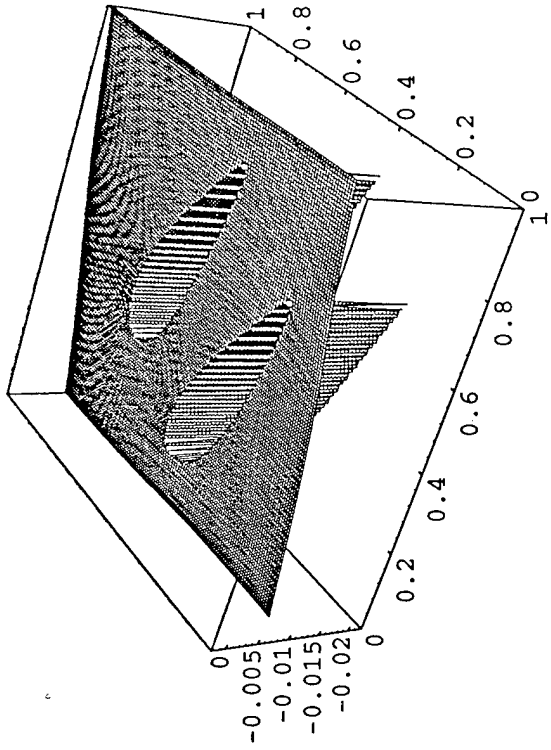

Figure (3.1.1-16) Closely Couple Airfoils, (128x128)
Potential Function in 3D

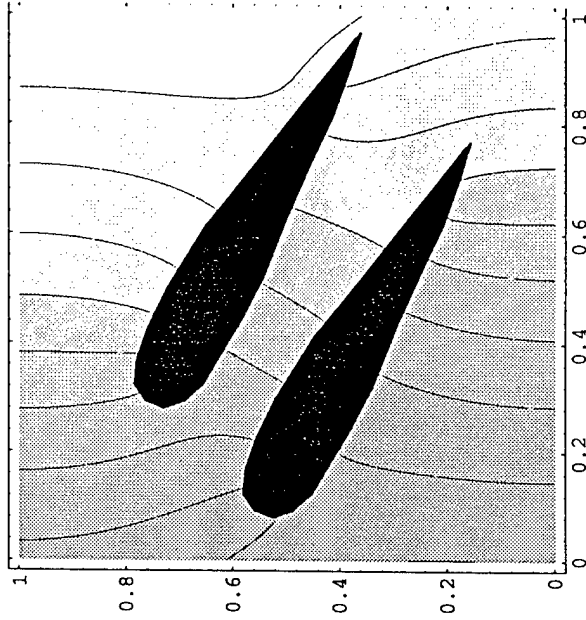

Figure (3.1.1-18) Closely Couple Airfoils, (128x128)
Potential Function Contours

lier, the length details of this theory can be found in [Ku2].

Finally, the work in [KKP] and depicted in figures (3.1.1-15) through (3.1.1-18) demonstrate how the results of [LRT] and [DM] can be extended to derive wavelet-based finite elements. These specialized techniques provide an effective means for representing more complex geometry, such as the study of flow/structure interaction effects in closely coupled airfoils depicted in figures (3.1.1-15) through (3.1.1-18).

(2) Development of Analytical Flutter Analysis and Experimental Facilities

Aeroelastic instabilities, which may be catastrophic, occur as a result of coupling between aerodynamic forces, structural forces, and inertial forces. Therefore, the aeroelastic design of aircraft must address the structure and the aerodynamic forces within the flight environment. The proposed program of research will initially use a structural experiment limited to two degrees of freedom shown schematically in figure (3.2.2-1). The actual experimental setup is depicted in figure (3.2.2-3) and has been incorporated in the 3' x 4' subsonic wind tunnel at Texas A&M.

The structure has been designed to implement a continuous nonlinear response which represents an extension of recent research in piecewise linear models which account for a deadband in linear response. The equations of motion for the nonlinear aeroelastic model representing the wing section limited to the pitch and plunge degrees of freedom can be written as:

$$I\ddot{\alpha} + mr\ddot{y}\cos(\alpha + \phi) + K_{\alpha}(\alpha + b\alpha^3) + C_{\alpha}\dot{\alpha} = M$$

$$m\ddot{y} + mr\ddot{\alpha}\cos(\alpha + \phi) - mr\dot{\alpha}^2\sin(\alpha + \phi) + K_y(y + \alpha y^3) + C_y\dot{y} = -N\cos(\alpha + \phi)$$

where

$$N \equiv N[y, \dot{y}, \alpha, \dot{\alpha}, t; \phi, AR, \text{planform}]$$

$$M = M[y, \dot{y}, \alpha, \dot{\alpha}, t; \phi, AR, \text{planform}]$$

and where the overdots represent time derivatives, y and α are the plunge and pitch coordinates, C_y and C_{α} are the damping coefficients for the support, K_y and K_{α} are the spring constants, a and b are of nonlinear spring constants, ϕ is the static angle of attack, m is the mass, I is the mass moment of inertia about the elastic axis, r is the distance between the elastic axis and the center of the mass, N is the aerodynamic normal force, and M is the aerodynamic pitching moment.

The linear form of these equations are found in several texts on the subject of aeroelasticity. The equations are coupled by the motion and the parameter, r . The equations appear to be uncoupled for the case when $r = 0$; yet, it is important to note that the aerodynamics of the above equations can take many forms but even the most elementary models of unsteady aerodynamic behavior provide coupling between the two degrees of freedom. Nonlinear models for the translational and torsional springs have been employed in these equations as well as the experimental setup.

Simulation results for a two degree-of-freedom model of the actual structure which use a linear model of the structure are presented in Figure 3.2.2-2. The results illustrate classical aeroelastic behavior. T_1 and T_2 represent periods unique to the individual degrees of freedom. However, in this case we note a transition to a period of T_3 . The frequencies have coalesced and the motion in the rotational degree of freedom (α) is increasing - both indications of an

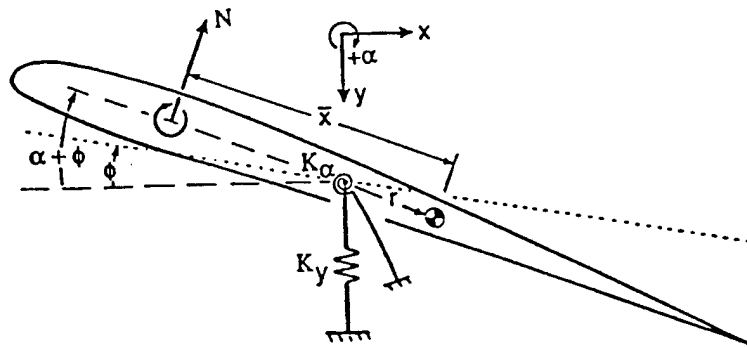

Figure (3.2.2-1) Schematic of Analytical Model / Experiment

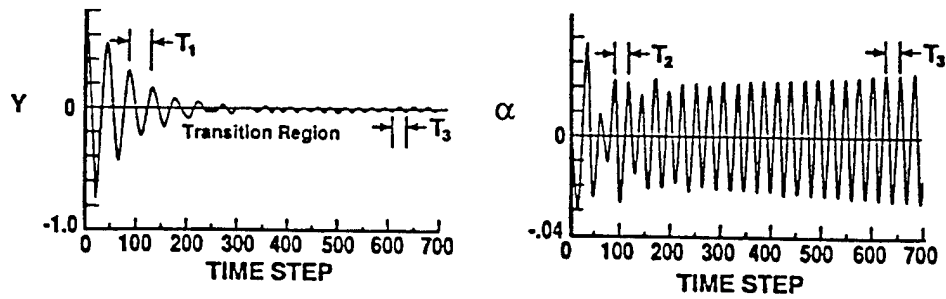

Figure (3.2.2-2) Transient Response for Linearized Model

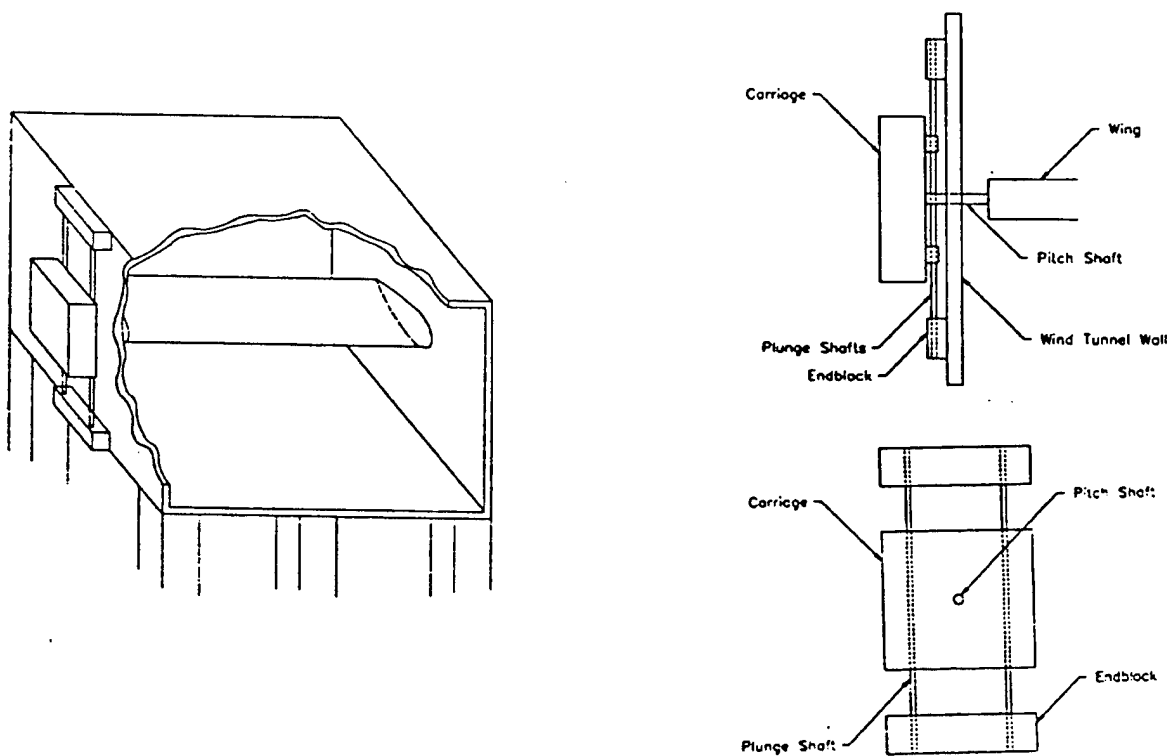

Figure (3.2.2-3) Schematic of Experimental Setup

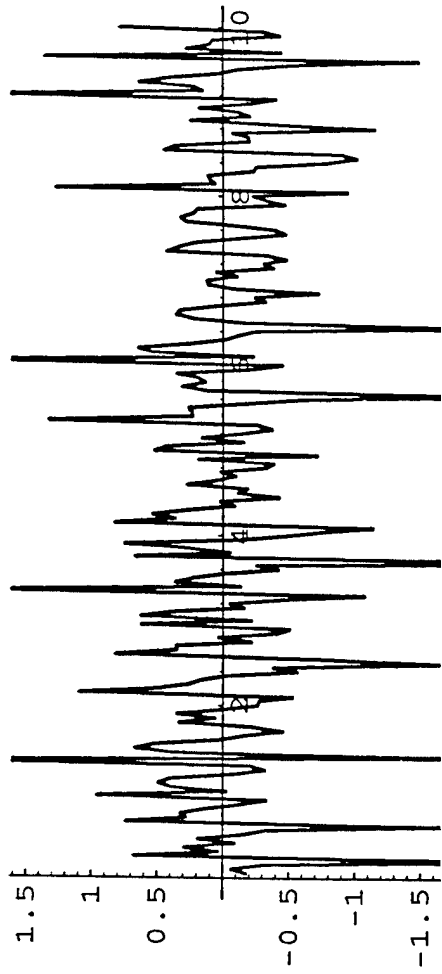

Figure (3.2.2-4) Transient Response of Experiment, Plunge

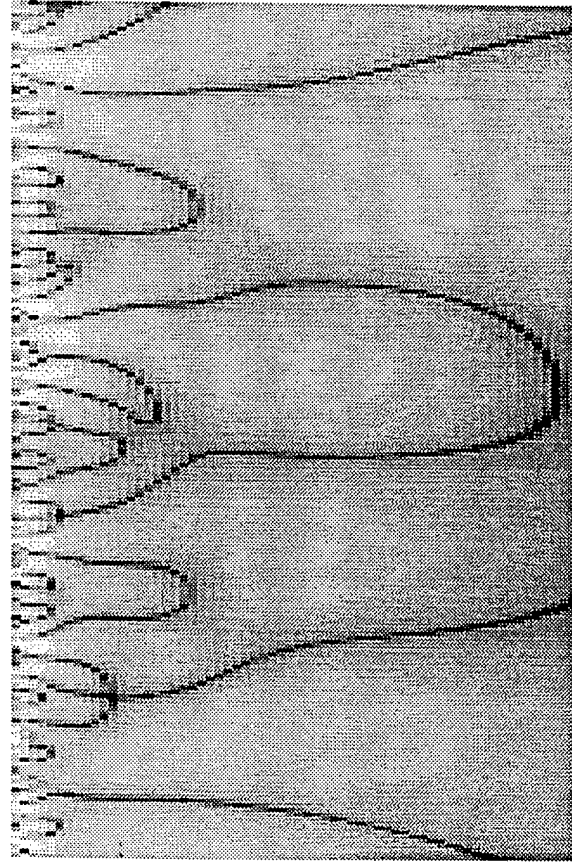

Figure (3.2.2-6) Wavelet Transform of Experimental Response, Plunge

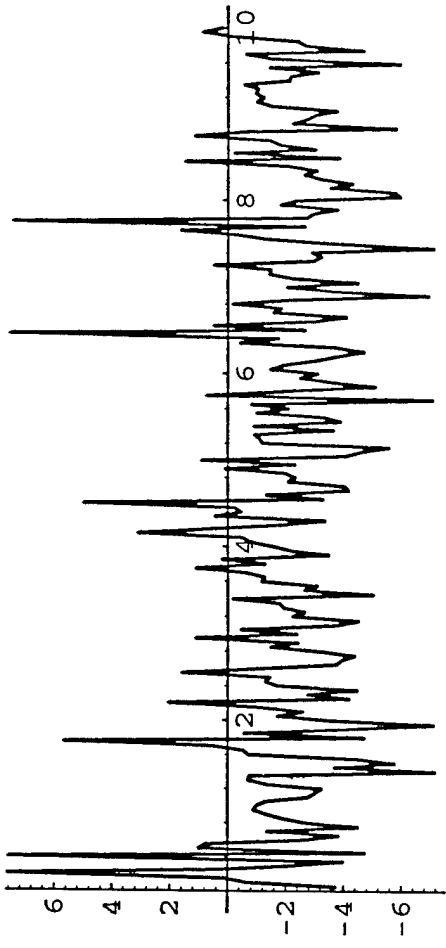

Figure (3.2.2-5) Transient Response of Experiment, Pitch

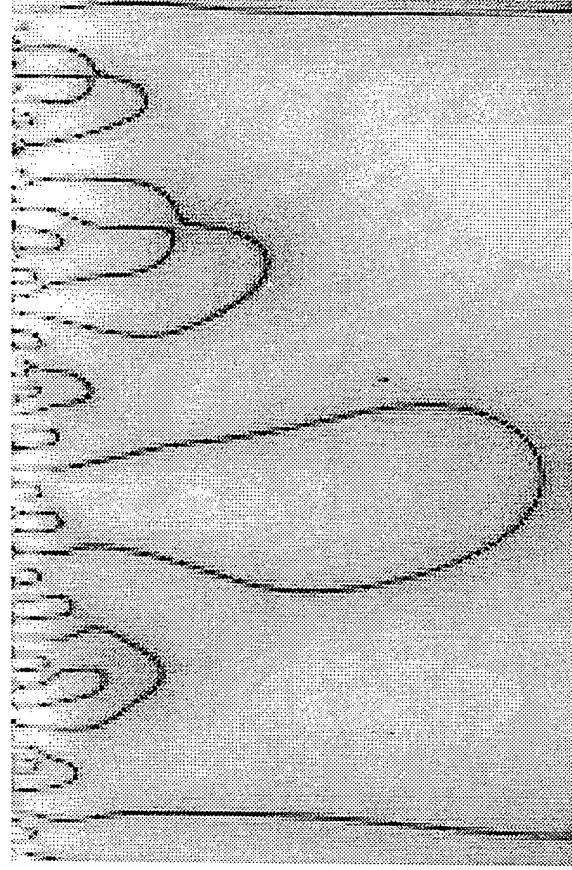

Figure (3.2.2-7) Wavelet Transform of Experimental Response, Pitch

aeroelastic instability. The complexity of the response actually observed in the wind tunnel for the experimental setup is evident from figures (3.2.2-4) and (3.2.2-5), which represent the transient response of the nonlinear system in pitch and plunge, respectively. Obviously, the response of the experimental system, that is subject to nonlinearities in aerodynamics and structural dynamics, differs profoundly from that predicted by linear theory in figure (3.2.2-2). Just as importantly, it is extremely difficult to locate or predict when these forms of pathological response will occur. This observation reflects an important feature of several of the current methods of study of nonlinear dynamics. That is, many researchers concern themselves with the *observation* and *identification* of pathological response in a given system, be it a physical system or a mathematical model. The research herein characterizes the *transition* to instabilities. This latter approach is of much greater value to the designer. In comparison to the integral wavelet transforms of the last section, figures (3.2.2-6) and (3.2.2-7) illustrate the time-frequency representations that closely resemble the bifurcation diagrams commonly used for the study of instability in nonlinear dynamical system theory. This proposal will investigate the use of the "coalescence of frequencies with scale" evident in the wavelet transforms depicted in figures (3.2.2-6) and (3.2.2-7) as a means of characterizing transition to instability.

(3) References

- [A] B. K. Alpert, "Wavelets and Other Bases for Fast Numerical Linear Algebra," Wavelets: A Tutorial in Theory and Applications, Editor: Chui, Academic Press, 181-216, 1992.
- [Ba] I. Babuska, "The Finite Element Method with Lagrange Multipliers", *Numer. Math.*, 20, pp. 179-192, 1973.
- [Bar] M. Barnsley, *Fractal Everywhere*, Academic Press, Boston, 1988.
- [BDY] R. E. Bank, T. F. Dupont, and Y. Yserentant, "The Hierarchical Basis Multigrid Method," *Numerical. Math.*, 52, 427-458, 1988.
- [BS] R. E. Bank and R. K. Smith, "A Posteriori Error Estimates Based on Hierarchical Bases," *SIAM Journal on Numerical Analysis*, Volume 30, Number 4, pp. 921-935, August, 1993.
- [BE] G. Beylkin, "On the Representation of Operators in Bases of Compactly Supported Wavelets," preprint, 1992.
- [BCR] G. Beylkin, R. Coifman, and V. Rokhlin, "Fast Wavelet Transforms and Numerical Algorithms I," *Communications on Pure and Applied Mathematics*, Vol. XLIV, 141-183, 1991.
- [BR] C. Brislawn and I. G. Rosen, "Wavelet Based Approximation in the Control of Distributed parameter Systems," *Numerical Functional Analysis and Optimization*, 12, 33-77, 1991.
- [BF] F. Brezzi and M. Fortin, *Mixed and Hybrid Finite Element Methods*, Springer Verlag, New York, 1991.
- [Ca] C. Canuto, et. al., *Spectral Methods in Fluid Dynamics*, Springer Verlag, New York, 1988.
- [Ch] C. K. Chui, Wavelets: A Tutorial in Theory and Applications, Academic Press, 1992.
- [Ci] P. Ciarlet, The Finite Element Method for Elliptic Problems, North-Holland Co., 1978.
- [DK] W. Dahmen and A. Kunoth, "Multilevel Preconditioning," preprint, 1992.
- [D] I. Daubechies, "Orthonormal Bases of Compactly Supported Wavelets," *Communications on Pure and Applied*

Mathematics, Vol. XLI, 909-996, 1988.

[DM] W. Dahmen and Charles A. Michelli, "Using the Refinement Equation for Evaluating Integrals of Wavelets," *SIAM Journal on Numerical Analysis*, Volume 30, Number 2, pp. 507-537, April, 1993.

[DP] R. A. DeVore and V. A. Popov, "Interpolation of Besov Spaces," *Transactions of the American Mathematical Society*, 305, 1, January, 1988.

[EV] V. Eijkhout and P. Vassilevski, "The Role of the Strengthened Cauch-Buniakowskii-Schwarz Inequality in Multilevel Methods," *SIAM Review*, 33, 3, 405-419, September, 1991.

[F] C.A. Fletcher, *Computational Techniques for Fluid Dynamics*, Volume II, Springer Verlag, New York, 1991.

[FZ] P. Frick and V. Zimin, "Hierarchical Models of Turbulence," *Wavelets, Fractals and Fourier Transforms*, M.Farge, J.C.R. Hunt and J.C. Vassilicos, eds., pp. 325-340, Carendon Press, Oxford, 1993.

[GB] W. Gui and I. Babuska, "The h, p and h-p Versions of the Finite Element Method, 1: The Error Analysis of the P-Version, 2: The Error Analysis of the h and h-p Versions, 3: The Adaptive h-p version," *Numer. Math.*, 48, pp. 557-612, pp. 613-657, pp. 658-683, 1986.

[GFG] N. Gache, Patrick Flandrin, and D. Garreau, "Fractal Dimension Estimators for Fractional Brownian Motions," CH2977-7/91, IEEE, pp. 3557-3560, July, 1991.

[GLRT] R. Glowinski, W. M. Lawton, M. Ravachol, and E. Tenenbaum, "Wavelet Solution of Linear and Nonlinear Elliptic, Parabolic and Hyperbolic Problems in One Space Dimension," *Technical Report AD890527.1*, Aware Inc., 1989.

[H] Hughes, T.J.R., *The Finite Element Method*, Prentice-Hall, Englewood Cliffs, New Jersey, 1987.

[HK1] S.E. Hanneman and V.K. Kinra, "A New Technique for Ultrasonic Nondestructive Evaluation of Adhesive Joints: Part I. Theory," *Experimental Mechanics*, Vol. 32, No. 4, pp. 323-331, December, 1992.

[HK2] S.E. Hanneman and V.K. Kinra, "A New Technique for Ultrasonic Nondestructive Evaluation of Adhesive Joints: Part I. Experiment," *Experimental Mechanics*, Vol. 32, No. 4, pp. 332-339, December, 1992.

[J] P.T. Jaminet, *Ultrasonic Quantitative NDE of Layered Media: The Inverse Problem*, Master of Science Thesis, Department of Aerospace Engineering, Texas A&M University, College Station, Texas, 77843-3141, December, 1993.

[JL] S. Jaffard, and Ph. Laurencot, "Orthonormal Wavelets, Analysis of Operators, and Applications to Numerical Analysis," *Wavelets: A Tutorial in Theory and Applications*, Editor: Chui, Academic Press, 543-601, 1992.

[JEF] J.G. Jones, P.G. Earwicker, and G.W. Foster, "Multiple-Scale Correlation Detection, Wavelet Transforms and Multifractal Turbulence," *Wavelets, Fractals and Fourier Transforms*, M.Farge, J.C.R. Hunt and J.C. Vassilicos, eds., pp. 235-250, Carendon Press, Oxford, 1993.

[KNK] A.J. Kurdila, F.J. Narcowich, and W.L. Kealey, "Fractal Interpolation of Strange Attractors in Adaptive Control of Attitude Dynamics," *Proceedings of the AIAA Guidance, Navigation and Control Conference*, AIAA paper no. 91-2705, pp. 894-907, August, 1991.

[KKS] J. Ko, A. Kurdila, and T. Strganac, "Calculation of Numerical Boundary Measure for Wavelet-Galerkin Approximations in Aeroelasticity," *34th Structures, Structural Dynamics and Materials Conference*, April, 1993.

[KKKS] J. Ko, C. Kim, A. Kurdila, and T. Strganac, "Wavelet Galerkin Methods for Game Theoretic Control of Distributed Parameter Systems," *34th Structures, Structural Dynamics and Materials Conference*, April, 1993.

[KKP] J. Ko, A. Kurdila, M. Pilant, "A Class of Wavelet-Based Finite Element Methods for Computational Mechan-

ics," *35th Structures, Structural Dynamics and Materials Conference*, April, 1994.

[KKW] J. Ko, A. Kurdila, Raymond Wells, and X. Zhou, "Stability of Numerical Boundary Measures in Computational Mechanics," *35th Structures, Structural Dynamics and Materials Conference*, April, 1994.

[KJKNB] A.J. Kurdila, J.L. Junkins, W.L. Kealey, F.J. Narcowich, and M.P. Bakich, "Approximation of Poincare Sections Arising in Attitude Control," *Advances in the Astronautical Sciences*, Volume 76, Part III, pp. 1721-1735.

[KZ] V.K. Kinra and C. Zhu, "Time-Domain Ultrasonic NDE of the Wave Velocity of a Sub-Half-Wavelength Elastic Layer," *Journal of Testing and Evaluation*, JTEVA, Vol. 21, No. 1, January, 1993, pp. 29-35.

[LRT] A. Latto, H. L. Resnikoff, and E. Tenenbaum, "The Evaluation of Connection Coefficients of Compactly Supported Wavelets," *Technical Report AD910708*, Aware Inc., 1991.

[M] C. Meneveau, "Wavelet Analysis of Turbulence," *Wavelets, Fractals and Fourier Transforms*, M.Farge, J.C.R. Hunt and J.C. Vassilicos, eds., pp. 251-264, Carendon Press, Oxford, 1993.

[Ma] S. G. Mallat, "A Theory for Multi Resolution Signal Decomposition: The Wavelet Representation," *IEEE Transactions on Pattern Analysis and Machine Intelligence*, 11, 7, 674-693, July, 1989.

[MB] I. Mareels and R.R. Bitmead, "Nonlinear Dynamics in Adaptive Control : Chaotic and Periodic Stabilization," *Automatica*, Vol. 22, No. 4, 1988, pp. 485-497.

[Mc] S.F. McCormick, *Multilevel Adaptive Methods for Partial Differential Equations*, Society for Industrial and Applied Mathematics, SIAM, Philadelphia, 1989 .

[O] P. Oswald, "Hierarchical Conforming Finite Element Methods for the Biharmonic Equation," *SIAM J. Numer. Anal.*, 29, 6, 1610-1625, December, 1992.

[P] L. Plaskota, "Optimal Approximation of Linear Operators Based on Noisy Data on Functionals," *Journal of Approximation Theory*, 73, 93-105, 1993.

[PC] T.S. Parker and L.O. Chua, *Practical Numerical Algorithms for Chaotic Systems*, Springer-Verlag, New York, 1989.

[R] H. L. Resnikoff, "Wavelets and Adaptive Signal Processing," *Technical Report AD910708*, Aware Inc., 1991.

[S] D. B. Spalding, "A Novel Finite Difference Formulation for Differential Expressions Involving Both First and Second Derivatives," *Int. J. Numer. Meth. Eng.*, 4, 1972, 557-559.

[SB] B. Szabo and I. Babuska, *Finite Element Analysis*, John Wiley & Sons, Inc., New York, 1991.

[SKV] Sang-Young Park, A.J. Kurdila, and Rao Vadali, "Wavelet Galerkin Multigrid Methods," *35th Structures, Structural Dynamics and Materials Conference*, April 18-21, 1994.

[V] J.C. Vassilicos, "Fractals in Turbulence," *Wavelets, Fractals and Fourier Transforms*, M.Farge, J.C.R. Hunt and J.C. Vassilicos, eds., Carendon Press, Oxford, 1993.

[WZ1] R. O. Wells, Jr., and X. Zhou, "Wavelet Interpolation and Approximate Solutions of Elliptic Partial Differential Equations," *Technical Report 92-03*, Rice University, Computational Mathematics Laboratory.

[WZ2] R. O. Wells, Jr. and X. Zhou, "Wavelet Solutions for the Dirichlet Problem," *Technical Report 92-02*, Rice University, Computational Mathematics Laboratory.

[Y1] H. Yserentant, "Hierarchical Bases Give Conjugate Gradient Type Methods a Multigrid Speed of Convergence," *Applied Mathematics and Computation*, 19, 347-358, 1986.

[Y2] H. Yserentant, "On the Multi-Level Splitting of Finite Element Spaces," *Numer. Math*, 49, 379-412, 1986.

[Y3] H. Yserentant, "Two Preconditioners Based on the Multi-Level Splitting of Finite Element Spaces," *Numer. Math.*, 58, 163-184, 1990.

[YG] B.E. Ydstie and M.P. Golden, "Chaos and Strange Attractors in Adaptive Control Systems," IFAC 10th Triennial World Congress, Munich, FRG, 1987, pp. 133-138.

Attachments

(1) *Calculation of Numerical Boundary Measures for Wavelet Approximations in Aeroelasticity*, A.Kurdila, J. Ko and T. Strganac, AIAA-93-1539.

(2) *Nonlinear Flutter of Composite Plates with Damage Evolution*, Y. Kim, T.Strganac and A.Kurdila, AIAA-93-1546.

(3) *Wavelet-Galerkin Methods for Game Theoretic Control of Distributed Parameter Systems*, A.Kurdila and J.Ko, AIAA-93-1674

(4) *Dynamic Response and Game Theoretic Control of Evolving Structural Systems*, T. Strganac, A. Kurdila, C.Kim and Y. Kim, AIAA-94-1720.

Attachment (1)

(1) *Calculation of Numerical Boundary Measures for Wavelet Approximations in Aeroelasticity*,
A.Kurdila, J. Ko and T. Strganac, AIAA-93-1539.

Calculation of Numerical Boundary Measure for
Wavelet-Galerkin Approximations
in Aeroelasticity

Jeonghwan Ko, Andrew J. Kurdila, and Thomas Strganac

Center for Mechanics and Control
Department of Aerospace Engineering
Texas A&M University
College Station, Texas 77843-3141

Abstract

Wavelet analysis is regarded as an extremely promising tool for approximate solution of multi-field problems, such as those arising in aeroelasticity and fluid structure interaction, due to its inherent multi-resolution/multi-scale nature. However, wavelet analysis has been conducted primarily within the fields of signal and image processing due to the difficulty in defining wavelet bases that satisfy specified boundary conditions. This paper employs an embedded domain technique to ameliorate the difficulty associated with deriving a wavelet basis for a specific multi-field initial/boundary value problem. Instead of constructing an explicit wavelet basis over the domain of interest, boundary conditions are enforced using a penalty formulation that requires the calculation of a numerical boundary measure. This paper presents strategies for the rapid calculation of numerical boundary measures employed in wavelet-Galerkin approximations of problems in aeroelastic transient response and control. In addition, the impact of new wavelet quadrature truncation error bounds is discussed in the context of aeroelastic simulation and control.

(I) Introduction

In 1988, Daubechies introduced a class of compactly supported wavelet functions which give a new decomposition of $L^2(\mathbf{R})$, and by tensor products, $L^2(\mathbf{R}^n)$. Since these functions combine orthogonality with localization and scaling properties, there have been a number of applications in engineering, especially in image and signal processing^{1,2,3}. But recently, the application of wavelets in the approximate solution for partial differential equation has become an area of active research.

For the most part, this research has focussed on two distinct problems:

- (i) representation of arbitrary boundary conditions in a wavelet basis, and
- (ii) derivation of wavelet bases that are tailored to the differential operator under consideration.

Representative work dealing with these topics can be found in⁴. Both of these problems are indeed formidable, and are guaranteed to be the source of research over the next few years. One difficulty associated with the representation of arbitrary boundary conditions is that some wavelet bases cannot be expressed in closed form. Combined with the fact that the wavelet bases are often not interpolatory, prescribing basis systems of desired smoothness and assuming specified values at the boundary can be difficult. With respect to the second class of problems, some progress has been made for specific combinations of differential operators and boundary conditions. Within these tailored basis systems, the differential operator can be expressed in a diagonal form and results in simplified computational schemes. As one might expect, however, the class of differential operators and boundary conditions for which this may be accomplished is rather limited and progress in research is made slowly.

This paper circumvents the difficulties associated with adapting a wavelet basis to a given differential operator or domain by employing a penalty implementation of the governing differential equations. The penalty formulation embodies domain embedding methods that have a well established theoretical foundation in computational mechanics⁵. As will be demonstrated in this paper, the critical task in this formulation is the rapid and accurate calculation of specific boundary integrals associated with the boundary conditions. These integrals may be approximated using numerical boundary measures introduced by⁶, or by employing alterna-

tive approximations derived in the paper. The numerical comparison of the wavelet galerkin formulations in aeroelasticity is based upon the panel flutter transient response and control problem studied, for example, in ⁷ and ⁸.

(II) The Fluid-Structure-Control Model

Aeroelasticity is defined as the phenomenon resulting from the interaction between aerodynamic, inertial, and elastic forces. While the class of problems in fluid-structure interaction to which the theory presented in this paper is vast, the panel flutter problem has been selected to demonstrate the underlying principles in wavelet galerkin approximation methods. The panel flutter problem has been studied by many distinguished researchers over the years ^{8,9,10} and has recently received renewed interest due to advances in actuation using active materials ^{7,11}. Dowell ¹² briefly describes the change in the aeroelastic stability arising from the degradation of isotropic panels. In this research, ¹² suggests that nonlinear flutter analysis permits the prediction of the fatigue life of the associated panel structure. This work shows that the conventional fatigue data may be used for estimating the life of the panel at flutter conditions if stress levels and frequency are known. Mei et. al. ¹³ studies the fatigue life of beams with thermal effects. Frequencies and stresses for limit cycle motions of these structures subject to various thermal loadings are determined. The critical dynamic pressure and fatigue life history are determined. These results provide a dynamic pressure at which infinite fatigue life is guaranteed. Chen et. al. ¹⁰ present flutter studies of thin cracked panels. The structure is assumed to behave in a linear manner and only single cracks are considered. A hybrid-displacement finite element is used in order to facilitate modeling the singularity near the crack tip. The influence of crack lengths and flow directions on the critical dynamics pressure is presented.

As noted earlier, several relatively new open questions have arisen regarding the simulation and control of panel flutter using actuation devices comprised of active materials. Scott ⁷ presents an optimization strategy based on linear quadratic control design to suppress flutter using adaptive piezoelectric materials. While ¹¹ presents an interesting approach to the use of adaptive materials to reduce stress concentrations in the vicinity of a crack tip, few authors have considered the effect of damage, evolution, or loss of actuation authority in control strategies employing adaptive materials. The current paper extends the recent work in ¹³ on robust control of distributed parameter systems by considering

$$\begin{aligned} & \rho h \frac{\partial^2 y}{\partial t^2} + EI \frac{\partial^4 y}{\partial x^4} + c_1 \frac{\partial y}{\partial t} + k_1 y \\ & - \frac{\rho_\infty U_\infty^2}{M_\infty} \left(\frac{\partial y}{\partial x} + \frac{1}{U_\infty} \frac{\partial y}{\partial t} \right) \\ & = \sum_i^N g_i \frac{\partial^2}{\partial x^2} (H_i(x)) u_i(t) \end{aligned} \quad (1)$$

where

$$H_i(x) = H(x - \alpha_i) - H(x - \beta_i) \quad (2)$$

and where ρ is the material density, h is the laminae thickness, EI is the bending modulus, c_1 is the viscous damping coefficient, k_1 is the stiffness constant of the beam foundation, and g_i is the piezoelectric gain. Each g_i depends upon the specific laminate geometry. The interested reader should see ¹⁴ or ¹⁵ for details. The remainder of this paper will be concerned with the wavelet-galerkin approximation of the above equation for obtaining transient response and control design.

(III) Multiresolution Analysis

All derivations in this paper employ Daubechies wavelets, which are introduced in ¹⁶. For each positive N , there is a family of compactly supported wavelets of dimension $N - 1$. Let ϕ be the Daubechies scaling function of order N (ϕ in ¹⁶), and let $\{h_0, \dots, h_{2N-1}\}$ be the corresponding coefficients for the 2-scale difference equation

$$\phi(x) = \sqrt{2} \sum_{k=0}^{2N-1} h_k \phi(2x - k) \quad (3)$$

where the coefficients $\{h_0, h_1, \dots, h_{2N-1}\}$ satisfy

$$\sqrt{2} \sum_{k=0}^{2N-1} h_k = 2 \quad (4)$$

$$\sum_{k=0}^{2N-1} h_k h_{k+2l} = \delta_{0,l}, \quad l \in \mathbb{Z} \quad (5)$$

where $\delta_{l,m}$ is the Kronecker delta function. By choosing

$$b_k := (-1)^{k+1} h_{2N-1-k} \quad (6)$$

One can find compactly supported wavelet functions which are in $L^2(\mathbb{R})$ and which are defined using a fundamental wavelet

$$\psi(x) = \sum_{k=0}^{2N-1} b_k \phi(2x - k) \quad (7)$$

The functions ϕ and ψ both have support in the interval $[0, 2N - 1]$. The wavelet system associated with h is defined by the relationship

$$\begin{aligned} \phi_k^j(x) & := 2^{j/2} \phi(2^j x - k) \\ \psi_k^j(x) & := 2^{j/2} \psi(2^j x - k) \end{aligned} \quad (8)$$

where $k \in \mathbf{Z}$, $j \in \mathbf{Z}^+$ (the nonnegative integers). Then the above functions have following properties.

$$\text{supp} \left(\phi_k^j(x), \psi_k^j(x) \right) = \left[\frac{k}{2^j}, \frac{k+2N-1}{2^j} \right] \quad (9)$$

$$\|\phi_k^j\|_{L^2(\mathbf{R})} = 1 \quad (10)$$

$$\sum_{k \in \mathbf{Z}} \phi_k^j(x) = 2^{\frac{j}{2}}, \quad x \in \mathbf{R} \quad (11)$$

$$\int_{\mathbf{R}} x^m \psi(x) dx = 0, \quad m = 0, \dots, N-1 \quad (12)$$

Moreover $\phi, \psi \in C^{\alpha(N)}$ where, for example, $\alpha(2) \approx 0.55$, $\alpha(3) \approx 1.088$, $\alpha(4) \approx 1.618$.

Daubechies wavelets induce a specific multiresolution analysis of $L^2(\mathbf{R})$. Let, for $j \in \mathbf{Z}$,

$$V_j := \text{closure}(\text{span}\{\phi_k^j(x) : k \in \mathbf{Z}\}) \quad (13)$$

and let W_j be the orthogonal complement of V_j in V_{j+1} , then for fixed $j \in \mathbf{Z}$, $\{\phi_k^j\}$ is an orthonormal basis for V_j and $\{\psi_k^j\}$ is an orthonormal basis for W_j .

Then $L^2(\mathbf{R}) = \cup_j V_j$, that is, for any function $f \in L^2(\mathbf{R})$, if we let P_j denote the orthogonal projection $L^2(\mathbf{R}) \rightarrow V_j$, then P_j converges to f in the L^2 norm.

$$\lim_{j \rightarrow \infty} P_j f = f \quad (14)$$

The Mallat identity asserts that ¹⁷

$$V_j = V_0 \oplus W_0 \oplus \dots \oplus W_{j-1} \quad (15)$$

If one assumes an expansion of the form

$$f^j(x) = \sum_{k \in \mathbf{Z}} f^{j,0} \phi_k^j(x) \in V_j \quad (16)$$

then one can also write

$$f^j(x) = \sum_{k \in \mathbf{Z}} f^{0,0} \phi_k^j(x) + \sum_{i=0}^{j-1} \sum_{k \in \mathbf{Z}} f^{i,1} \psi_k^i(x) \in V_0 \oplus W_0 \oplus \dots \oplus W_{j-1} \quad (17)$$

where

$$f_k^{i,0} = \frac{1}{\sqrt{2}} \sum_l f_l^{i+1,0} h_{l-2k}, \quad 0 \leq i \leq j$$

$$f_k^{i,1} = \frac{1}{\sqrt{2}} \sum_l f_l^{i+1,0} b_{l-2k}, \quad 0 \leq i \leq j \quad (18)$$

Conversely, if one knows the coefficients of the expansion at level i , the coefficients at level $i-1$ are

$$f_k^{i,0} = \frac{1}{\sqrt{2}} \sum_l (f_l^{i-1,0} h_{k-2l} + f_l^{i-1,1} a_{k-2l}), \quad 0 \leq i \leq j$$

In ¹⁸ a theorem about the wavelet interpolation of a function in 2-D using only the scaling function is proven.

Theorem Assume the function $f \in C^2(\Omega)$, where Ω is a bounded open set in \mathbf{R}^2 . Let for $j \in \mathbf{N}$,

$$f^j(x, y) := \frac{1}{2^j} \sum_{p, q \in \Lambda} f \left(\frac{p+c}{2^j}, \frac{q+c}{2^j} \right) \phi_p^j(x) \phi_q^j(y),$$

where $x, y \in \Omega$, the index set $\Lambda = \{i \in \mathbf{Z} : \text{supp}(\phi_i^j) \cap \Omega \neq \emptyset\}$ and $c := \int x \phi dx = \frac{\sqrt{2}}{2} \sum_{k=0}^{2N-1} k h_k$. Then

$$\|f - f^j\|_{L^2(\Omega)} \leq C(1/2^j)^2$$

and

$$\|f - f^j\|_{H^1(\Omega)} \leq C/2^j$$

where C is a constant depending only on the diameter of Ω , N , and the maximum modulus of the first and second order derivatives of f on Ω .

In any application involving the approximate solution of partial differential equations using wavelets, it is essential to derive accurate representations of the weak form of the governing equations in the wavelet bases. For some classes of spline wavelets, the derivation of differentiation formulae is rather straightforward. However, the smoothness properties of Daubechies wavelets are rather abstract, the calculation of their derivatives is somewhat delicate. This task has been studied in ^{19,20,21} for exact quadratures. The effect of truncation error in the differentiation of Daubechies wavelets is discussed in ²²

The approach taken in this paper employs translations and dilations of the scaling function only as in ¹⁸, as opposed to using the associated wavelet bases themselves ¹⁹. As in the last section, if a function $F(x)$ has the approximate representation $F^j(x)$.

$$F^j(x) = \sum_{p \in \Lambda} F_p^j \phi_p^j(x) \quad (20)$$

Then one can differentiate this expression to achieve

$$\frac{dF^j}{dx}(x) = \sum_{p \in \Lambda} F_p^j \frac{d}{dx} (\phi_p^j(x)) \quad (21)$$

Consequently, the solution for the derivative of $F^j(x)$ reduces to the calculation of

$$\frac{d}{dx} (\phi_p^j(x)) \quad \text{for all } p \in N \quad (22)$$

However, one can always expand the derivative in terms of the basis functions

$$\frac{d}{dx} (\phi_p^j(x)) = \sum_k \alpha_{k,p} \phi_k^j(x) \quad (23)$$

Taking the L^2 -inner product of the above equation with an arbitrary basis function $\phi_r^j(x)$

$$\alpha_{r,p} = \int \frac{d}{dx} (\phi_p^j(x)) \phi_r^j(x) dx \quad (24)$$

and by using a change of variables one can show that

$$\alpha_{r,p} = 2^j \int \frac{d\phi}{d\xi}(\xi) \phi(\xi + r - p) d\xi \quad , \quad \xi = 2^j x + p$$

This equation is one example of the general two-term coefficients defined by ²⁰

$$\Lambda_{l_1, l_2}^{d_1, d_2} = \int \frac{d^{d_1}}{dx^{d_1}} \phi(x - l_1) \frac{d^{d_2}}{dx^{d_2}} (\phi(x - l_2)) dx$$

In particular,

$$\alpha_{r,p} = 2^j \Lambda_{0, p-r}^{1,0} \quad (26)$$

so that the final expression for the derivative of $F^j(x)$ becomes

$$\begin{aligned} \frac{dF^j}{dx}(x) &= \sum_{p \in \Lambda} F_p^j \sum_r 2^j \Lambda_{0, p-r}^{1,0} \phi_r^j(x) \\ &= \sum_{p \in \Lambda} \sum_r F_p^j \Lambda_{0, p-r}^{1,0} \phi_r^j(x) \end{aligned} \quad (27)$$

For the calculation of numerical boundary measure explained in later section, we also need the three-term connection coefficients defined by [Latto]

$$\begin{aligned} \Lambda_{l_1, l_2, l_3}^{d_1, d_2, d_3} &= \Lambda_{0, l_2 - l_1, l_3}^{d_1, d_2, d_3} \\ \phi(x - l_1) \frac{d^{d_2}}{dx^{d_2}} \phi(x - l_2) \frac{d^{d_3}}{dx^{d_3}} \phi(x - l_3) dx \end{aligned} \quad (28)$$

It is important to note that these connection coefficients can be calculated once, stored in a program and used repeatedly. Detailed discussions of their calculation can be found in ^{19,20,21}.

(IV) Domain Embedding, Wavelet Galerkin Methods

The domain embedding technique has been employed extensively in computational mechanics, and in particular, in studying subdomain decomposition methods. In this section, the wavelet galerkin penalty formulation for the one dimensional beam equation is derived. The extension to include aerodynamic terms in the panel flutter model and the associated equations for the control design of flutter suppression of plates are subsequently straightforward to derive. Consequently, the extension of the wavelet galerkin approximation of the beam equation incorporating aerodynamic terms to model panel flutter are simply stated without proof. The interested reader is referred to ²² for the details.

One can derive the weak formulation of the plate equations using a domain embedding technique by first defining the cost functional J_0 by

$$J_0(y) = \frac{1}{2} EI \int_D \left| \frac{\partial^2 y}{\partial x^2}(x) \right|^2 dx + \frac{1}{2} k_1 \int_D |y(x)|^2 dx - \int_D y(x) f(x) dx$$

To enforce the boundary conditions it is necessary to define the trace operator γ that evaluates the displacement

$$\gamma_0(y) = \left\{ \begin{array}{l} \gamma_{0,1}(y) \\ \gamma_{0,2}(y) \end{array} \right\} = \left\{ \begin{array}{l} y(a) \\ y(b) \end{array} \right\} \quad (30)$$

and the slopes at the boundary

$$\gamma_1(y) = \left\{ \begin{array}{l} \gamma_{1,1}(y) \\ \gamma_{1,2}(y) \end{array} \right\} = \left\{ \begin{array}{l} \frac{\partial y}{\partial x}(a) \\ \frac{\partial y}{\partial x}(b) \end{array} \right\} \quad (31)$$

By introducing the penalty terms on the boundary

$$\begin{aligned} J_\epsilon(y) &= \frac{1}{2\epsilon} \left\| \gamma_0(y) - \left\{ \begin{array}{l} y_a^0 \\ y_b^0 \end{array} \right\} \right\|^2 \\ &+ \frac{1}{2\epsilon} \left\| \gamma_1(y) - \left\{ \begin{array}{l} y_a^1 \\ y_b^1 \end{array} \right\} \right\|^2 \end{aligned} \quad (32)$$

a modified functional can be defined

$$J(y) = J_0(y) + J_\epsilon(y) \quad (33)$$

The Euler equations for the modified functional $J(y)$ define the necessary equations for equilibrium of the plate. In other words, by taking the Gateaux differential of $J_0(y)$

$$\begin{aligned} \langle DJ_0(y), v \rangle &= EI \int_D \frac{\partial^2 y}{\partial x^2}(x) \frac{\partial^2 v}{\partial x^2}(x) dx \\ &+ k_1 \int_D y(x) v(x) dx - \int_D v(x) f(x) dx \end{aligned} \quad (34)$$

and by taking the Gateaux differential of $J_\epsilon(y)$

$$\begin{aligned} \langle DJ_\epsilon(y), v \rangle &= \frac{1}{\epsilon} (\gamma_{0,1}(y) - y_a^0) \gamma_{0,1}(v) \\ &+ \frac{1}{\epsilon} (\gamma_{0,2}(y) - y_b^0) \gamma_{0,2}(v) \\ &+ \frac{1}{\epsilon} (\gamma_{1,1}(y) - y_a^1) \gamma_{1,1}(v) \\ &+ \frac{1}{\epsilon} (\gamma_{1,2}(y) - y_b^1) \gamma_{1,2}(v) \end{aligned} \quad (35)$$

the governing equations in weak, or variational form, become

$$\begin{aligned}
& EI \int_D \frac{\partial^2 y}{\partial x^2}(x) \frac{\partial^2 v}{\partial x^2}(x) dx + k_1 \int_D y(x)v(x) dx \\
& + \frac{1}{\epsilon} \gamma_{0,1}(y) \gamma_{0,1}(v) + \frac{1}{\epsilon} \gamma_{0,2}(y) \gamma_{0,2}(v) \\
& + \frac{1}{\epsilon} \gamma_{1,1}(y) \gamma_{1,1}(v) + \frac{1}{\epsilon} \gamma_{1,2}(y) \gamma_{1,2}(v) \\
& = \int_D v(x) f(x) dx \\
& + \frac{1}{\epsilon} y_a^0 \gamma_{0,1}(v) + \frac{1}{\epsilon} y_b^0 \gamma_{0,2}(v) \\
& + \frac{1}{\epsilon} y_a^1 \gamma_{1,1}(v) + \frac{1}{\epsilon} y_b^1 \gamma_{1,2}(v) \quad (36)
\end{aligned}$$

The galerkin approximation of the variational equations are obtained by substituting the expression for the approximate solution and trial function

$$\begin{aligned}
y &= \sum y_i^J(t) \phi_i^J(x) \\
v &= \sum v_i^J \phi_i^J(x) \quad (37)
\end{aligned}$$

With this substitution, the approximate equations become

$$\begin{aligned}
& \sum_i \int_0^1 \phi_i^J(x) \phi_i^J(x) dx \ddot{y}_i^J(t) \\
& + EI \sum_i \int_0^1 \phi_i^J(x) \frac{\partial^4}{\partial x^4} (\phi_i^J(x)) dx y_i^J(t) \\
& - \frac{\rho_\infty U_\infty^2}{M_\infty} \sum_i \int_0^1 \phi_i^J(x) \frac{\partial}{\partial x} (\phi_i^J(x)) dx y_i^J(t) \\
& - \frac{\rho_\infty U_\infty}{M_\infty} \sum_i \int_0^1 \phi_i^J(x) \phi_i^J(x) dx \dot{y}_i^J(t) \\
& + c_1 \sum_i \int_0^1 \phi_i^J(x) \phi_i^J(x) dx \dot{y}_i^J(t) \\
& + k_1 \sum_i \int_0^1 \phi_i^J(x) \phi_i^J(x) dx y_i^J(t) \\
& + \frac{1}{\epsilon} \sum_i \{ \phi_i^J(a) \phi_i^J(a) + \phi_i^J(b) \phi_i^J(b) \} y_i^J(t) \\
& + \frac{1}{\epsilon} \sum_i \left\{ \frac{\partial \phi_i^J}{\partial x}(a) \frac{\partial \phi_i^J}{\partial x}(a) + \frac{\partial \phi_i^J}{\partial x}(b) \frac{\partial \phi_i^J}{\partial x}(b) \right\} y_i^J(t) \\
& = \sum_i g_i \sum_r h_{i,r}^J \int_0^1 \phi_i^J(x) \frac{\partial^2}{\partial x^2} (\phi_r^J(x)) dx u_i(t) \\
& + \frac{1}{\epsilon} y_a^0 \phi_i^J(a) + \frac{1}{\epsilon} y_b^0 \phi_i^J(b)
\end{aligned}$$

$$+ \frac{1}{\epsilon} y_a^1 \frac{\partial \phi_i^J}{\partial x}(a) + \frac{1}{\epsilon} y_b^1 \frac{\partial \phi_i^J}{\partial x}(b) \quad (38)$$

To obtain the final equations in the wavelet basis, one need only substitute the equations derived in the last expression for differentiating wavelets in terms of the connection coefficients, or wavelet quadratures, $\Lambda_{i,j}^{k,l}$

$$\begin{aligned}
& \sum_i \left(\delta_{l,i} \ddot{y}_i^J(t) + \left(c_1 - \frac{\rho_\infty U_\infty}{M_\infty} \right) \delta_{l,i} \dot{y}_i^J(t) \right) \\
& + \sum_i \left(k_1 \delta_{l,i} + 2^{4J} EI \Lambda_{i,i}^{2,2} - \frac{\rho_\infty U_\infty^2}{M_\infty} \Lambda_{i,i}^{0,1} \right) y_i^J(t) \\
& + \frac{1}{\epsilon} \sum_i \{ \phi_i^J(a) \phi_i^J(a) + \phi_i^J(b) \phi_i^J(b) \} y_i^J(t) \\
& + \frac{1}{\epsilon} \sum_i \sum_k \sum_r \{ \Lambda_{l,k}^{1,0} \Lambda_{i,r}^{1,0} \phi_k^J(a) \phi_r^J(a) \} y_i^J(t) \\
& + \frac{1}{\epsilon} \sum_i \sum_k \sum_r \{ \Lambda_{l,k}^{1,0} \Lambda_{i,r}^{1,0} \phi_k^J(b) \phi_r^J(b) \} y_i^J(t) \\
& = 2^{2J} \sum_i \sum_r \Lambda_{i,r}^{0,2} g_i h_{i,r}^J u_i(t) \\
& + \frac{1}{\epsilon} y_a^0 \phi_i^J(a) + \frac{1}{\epsilon} y_b^0 \phi_i^J(b) \\
& + \frac{1}{\epsilon} \sum_r \left\{ y_a^1 \Lambda_{i,r}^{1,0} \phi_r^J(a) + \frac{1}{\epsilon} y_b^1 \Lambda_{i,r}^{1,0} \phi_r^J(b) \right\} \quad (39)
\end{aligned}$$

- These final equations have several properties that make them attractive from a computational viewpoint:
- (i) The various coefficient matrices are highly sparse,
 - (ii) the wavelet quadratures are calculated once, prior to the simulation, and stored for application to any partial differential equation,
 - (iii) rapidly convergent diagonal preconditioning methods can be derived for representations of differential operators in the wavelet basis⁴, and
 - (iv) preliminary study by the authors have shown that multigrid wavelet procedures are rapidly convergent

However, it should be noted that the extension of the above equations to more general domains is much more difficult than appears in the one dimensional case. In the case of arbitrary domains in two dimensions, the penalty term that must be evaluated has the form

$$\frac{1}{\epsilon} \int_{\partial \Omega} u v dS \quad (40)$$

where Ω is the boundary of the plate and γ is the trace operator that evaluates a function defined on Ω at its boundary. The next two sections summarize methods for calculating these penalty terms for arbitrary boundaries.

(V) Geometric Measure Integrals

The first method is introduced by Wells¹⁸. Because it forms the basis for numerical studies and the new method presented in the next section, it is discussed in some detail in this section. Let Ω be an open bounded set in \mathbb{R}^2 , where boundary is defined by

$$\partial\Omega = \{(x, y) \in \mathbb{R}^2 : F(x, y) = \text{constant}\} \quad (41)$$

Then the unit normal vector \vec{n} along the boundary $\partial\Omega$ can be written as

$$\vec{n} = \frac{\nabla F}{|\nabla F|} \quad (42)$$

By extending \vec{n} to \mathbb{R}^2 "smoothly", we have the following formula for the arclength of $\partial\Omega$

$$\begin{aligned} L(\partial\Omega) &= \int_{\partial\Omega} ds = \int_{\partial\Omega} \vec{n} \cdot \vec{n} ds = \int_{\Omega} \text{div} \vec{n} dx dy \\ &= \int_{\mathbb{R}^2} \chi_{\Omega} \text{div} \vec{n} dx dy = - \int_{\mathbb{R}^2} \nabla \chi_{\Omega} \cdot \vec{n} dx dy \end{aligned}$$

where, χ_{Ω} is the characteristic function of Ω .

More generally, by the same derivation, one has for any integrable function f defined on $\partial\Omega$, after extending f to \mathbb{R}^2

$$\int_{\partial\Omega} f ds = - \int_{\mathbb{R}^2} f |\partial\Omega| \quad (44)$$

where $|\partial\Omega| = \nabla \chi_{\Omega} \cdot \vec{n} dx dy$.

Now one can develop the wavelet approximation of boundary integral. The wavelet expansion of the characteristic function χ_{Ω} and $F(x, y)$ at a level j is

$$\begin{aligned} \chi_{\Omega}^j(x, y) &= \sum_{p, q} \chi_{p, q}^j \phi_p^j(x) \phi_q^j(y) \\ F^j(x, y) &= \sum_{p, q} F_{p, q}^j \phi_p^j(x) \phi_q^j(y) \end{aligned} \quad (45)$$

Using the connection coefficients

$$\Lambda_{l, m}^{1, 0} := \int_{\mathbb{R}} \phi'_l \phi_m dx \quad (46)$$

it is possible to derive the expansion coefficients of the derivatives. The partial derivatives in terms of wavelet expansions are

$$\begin{aligned} \frac{\partial \chi_{\Omega}^j}{\partial x} &= \sum_{p, q} \left(\frac{\partial \chi}{\partial x} \right)_{p, q}^j \phi_p^j(x) \phi_q^j(y) \\ \frac{\partial \chi_{\Omega}^j}{\partial y} &= \sum_{p, q} \left(\frac{\partial \chi}{\partial y} \right)_{p, q}^j \phi_p^j(x) \phi_q^j(y) \\ \frac{\partial F^j}{\partial x} &= \sum_{p, q} \left(\frac{\partial F}{\partial x} \right)_{p, q}^j \phi_p^j(x) \phi_q^j(y) \\ \frac{\partial F^j}{\partial y} &= \sum_{p, q} \left(\frac{\partial F}{\partial y} \right)_{p, q}^j \phi_p^j(x) \phi_q^j(y) \end{aligned} \quad (47)$$

For large j , one can accurately approximate the values of $\frac{\partial F}{\partial x}$ and $\frac{\partial F}{\partial y}$ at the interior points by their corresponding coefficients, i.e.

$$\frac{\partial F}{\partial x}(p, q) \approx 2^j \left(\frac{\partial F}{\partial x} \right)_{p, q}^j, \quad \frac{\partial F}{\partial y}(p, q) \approx 2^j \left(\frac{\partial F}{\partial y} \right)_{p, q}^j$$

Thus

$$|\nabla F|(p, q) \approx 2^j \sqrt{\left(\left(\frac{\partial F}{\partial x} \right)_{p, q}^j \right)^2 + \left(\left(\frac{\partial F}{\partial y} \right)_{p, q}^j \right)^2}$$

Letting $\vec{n} = (n_x, n_y)$,

$$n_x(p, q) \approx \frac{\left(\frac{\partial F}{\partial x} \right)_{p, q}^j}{\sqrt{\left(\left(\frac{\partial F}{\partial x} \right)_{p, q}^j \right)^2 + \left(\left(\frac{\partial F}{\partial y} \right)_{p, q}^j \right)^2}} \quad (50)$$

therefore the expansion of n_x, n_y are,

$$\begin{aligned} n_x^j &= \sum_{p, q} \frac{\left(\frac{\partial F}{\partial x} \right)_{p, q}^j}{\sqrt{\left(\left(\frac{\partial F}{\partial x} \right)_{p, q}^j \right)^2 + \left(\left(\frac{\partial F}{\partial y} \right)_{p, q}^j \right)^2}} \phi_p^j(x) \phi_q^j(y) \\ n_y^j &= \sum_{p, q} \frac{\left(\frac{\partial F}{\partial y} \right)_{p, q}^j}{\sqrt{\left(\left(\frac{\partial F}{\partial x} \right)_{p, q}^j \right)^2 + \left(\left(\frac{\partial F}{\partial y} \right)_{p, q}^j \right)^2}} \phi_p^j(x) \phi_q^j(y) \end{aligned}$$

And the numerical boundary measure $|\partial\Omega|$ is

$$|\partial\Omega| = \nabla \chi_{\Omega} \cdot \vec{n} dx dy \quad (53)$$

$$|\partial\Omega| = \sum_{p, q} (|\partial\Omega|)_{p, q}^j \phi_p^j(x) \phi_q^j(y) dx dy$$

Substitute wavelet expansion of $\nabla \chi_{\Omega}$, and \vec{n} , take inner product with $\phi_p^j(x) \phi_q^j(y)$, and use the three term connection coefficients

$$\Lambda_{p, k, s}^{0, 0, 0} = \int_{\mathbb{R}} \phi_p(x) \phi_k(x) \phi_s(x) dx \quad (54)$$

then we obtain

$$(|\partial\Omega|)_{p, q}^j = \quad (55)$$

$$\sum_{k, l, s, t} \frac{\left[\left(\frac{\partial \chi}{\partial x} \right)_{k, l}^j \left(\frac{\partial F}{\partial x} \right)_{s, t}^j + \left(\frac{\partial \chi}{\partial y} \right)_{k, l}^j \left(\frac{\partial F}{\partial y} \right)_{s, t}^j \right] \Gamma_{p, k, s} \Gamma_{q, l, t}}{2^j \sqrt{\left(\left(\frac{\partial F}{\partial x} \right)_{s, t}^j \right)^2 + \left(\left(\frac{\partial F}{\partial y} \right)_{s, t}^j \right)^2}}$$

Now we have a formula for calculating the arclength

$$\begin{aligned} L(\partial\Omega) &= - \int_{\mathbb{R}^2} \sum_{p,q} (||\partial\Omega||)_{p,q}^j \phi_p^j(x) \phi_q^j(y) dx dy \\ &= - \int_{\mathbb{R}^2} ||\partial\Omega|| = - \sum_{p,q} (||\partial\Omega||)_{p,q}^j \end{aligned} \quad (56)$$

(VI) Positive, Symmetric Boundary Measures

As will be seen in Section (VII), while the numerical boundary measure described in the last section can be effective in direct calculation, numerical examples have shown that it does not preserve the positive, symmetric form of the terms arising penalty contribution to the variational equations. Specifically, for boundary integrals having the form

$$\frac{1}{\epsilon} \int_{\partial\Omega} u v dS \quad (57)$$

it is possible to derive a numerical scheme that retains the positive, symmetric attributes of the penalty term. By formula (??), one can always write

$$\int_{\partial\Omega} f dS = - \int_{\mathbb{R}^2} f \nabla \chi_{\Omega} \cdot \vec{n} dx dy \quad (58)$$

when f is extended to all of \mathbb{R}^2 . To obtain a symmetric, positive measure, one approximates the boundary

$$\partial\Omega^J = \{(x,y) \in \mathbb{R}^2: \chi_{\Omega}^J = 1\} \quad (59)$$

and the normal derivative to the approximate boundary

$$\vec{n} \approx \vec{n}^J = \frac{\nabla \chi_{\Omega}^J}{\|\nabla \chi_{\Omega}^J\|} \quad (60)$$

By assuming the form of the solution and trial functions to be a linear superposition of wavelet scaling functions,

$$\begin{aligned} u &= \sum u_{ab}^J \phi_a^J(x) \phi_b^J(y) \\ v &= \sum v_{cd}^J \phi_c^J(x) \phi_d^J(y) \end{aligned} \quad (61)$$

the final form of discrete approximation for domain embedding is obtained

$$\begin{aligned} &\frac{1}{\epsilon} \int_{\partial\Omega} u v dS \\ &= \frac{1}{\epsilon} \sum \left(\chi_{p,q}^J \chi_{s,t}^J \Lambda_{p,r}^{1,0} \Lambda_{s,l}^{1,0} \Lambda_{r,l,a,c}^{0,0,0,0} \Lambda_{q,t,b,d}^{0,0,0,0} \right) u_{ab}^J v_{cd}^J \\ &+ \frac{1}{\epsilon} \sum \left(\chi_{p,q}^J \chi_{s,t}^J \Lambda_{q,r}^{1,0} \Lambda_{t,l}^{1,0} \Lambda_{p,s,a,c}^{0,0,0,0} \Lambda_{r,l,b,d}^{0,0,0,0} \right) u_{ab}^J v_{cd}^J \end{aligned} \quad (62)$$

In the above equation,

$\Lambda_{a,b,c,d}^{0,0,0,0}$ are the four term connection coefficients defined to be

$$\Lambda_{a,b,c,d}^{0,0,0,0} = \int_{\mathbb{R}^2} \phi_a^J(x) \phi_b^J(x) \phi_c^J(x) \phi_d^J(x) dx dy \quad (63)$$

The calculation of the four term connection coefficients is discussed in ²³.

(VII) Numerical Examples

Several numerical examples have been carried out to verify the accuracy and consistency of the formulation for the 1-D wavelet galerkin approximation of the panel represented in eqs. (39). Figures (1) through (6) depict the solution of the boundary value problem *without aerodynamic terms* to study the overall convergence rate of the wavelet-galerkin, embedded domain problem. In the first simulation, shown in figures (1) and (2), a clamped panel has been modeled. Figure (1) depicts the solution on the full domain, while Figure (2) illustrates the solution on the physical domain for several resolution levels. Similar results are shown in Figures (3) and (4) for a simply supported panel, while Figures (5) and (6) depict the results for a clamped plate subject to a constant transverse load. Figures (7), (8) and (9) show the asymptotic rate of convergence plotted as a function of the resolution level. As expected, the convergence rate is $O(2^J)$.

Inasmuch as the numerical boundary measure is defined in a rather abstract manner, Figures (10) through (12) graphically illustrate the form of the boundary measure and its constituents. For example, Figure (10) illustrates the characteristic function of the circle ($x^2 + y^2 = 100$) at the sampling level $j=1$. Figure (4) depicts the boundary measure $||\partial\Omega||$ itself. Clearly, all the constituent functions comprising the boundary measure are highly sparse, as is expected in wavelet calculation of localized phenomena. The error in calculating the arclength of the perimeter of the circle is depicted in Table (1) and agree well with results presented in ¹⁸. Figure (11) is a characteristic function of the airfoil and the numerical boundary measure $||\partial\Omega||$ is shown in Figure (12). From these boundary measures, the approximated arclength of the boundary of the airfoil for the level $j = 4$ is

$$L = 8.219033$$

Future work will include the detailed study of the coupled fluid-structure-control interaction problem associated with the control of panel flutter using a wavelet galerkin formulation. In addition, fast multigrid algorithms for the solution of the resultant equations of motion have been developed.

(VIII) References

- ¹ Chui, C. K., *Wavelets : A Tutorial in Theory and Applications*, Academic Press, 1992.
- ² Mallat, S. G., "A Theory for Multi Resolution Signal Decomposition : The Wavelet Representation," *IEEE Transactions on Pattern Analysis and Machine Intelligence*, Vol. 11, No. 7, July 1989, pp. 674-693.
- ³ Hummel, R., and R. Moniot, "Reconstructions from Zero Crossings in Scale Space," *IEEE Transactions on Acoustics, Speech, and Signal Processing*, Vol. 37, No.12, December 1989, pp. 2111-2130.
- ⁴ Jaffard, S. and Laurencot, Ph., "Orthonormal Wavelets, Analysis of Operators, and Applications to Numerical Analysis," *Wavelets: A Tutorial in Theory and Applications*, Charles Chui, ed., Academic Press, pp. 543-601, 1992.
- ⁵ Glowinski, R., W. M. Lawton, M. Ravachol, and E. Tenenbaum, "Wavelet Solution of Linear and Nonlinear Elliptic, Parabolic and Hyperbolic Problems in One Space Dimension," Technical Report AD890527.1, Aware Inc., 1989.
- ⁶ Wells, R. O., Jr., and X. Zhou, "Wavelet Solutions for the Dirichlet Problem," Technical Report 92-02, Rice University, Computational Mathematics Laboratory.
- ⁷ Scott, R.C. and Weishaar, T.A., "Controlling Panel Flutter Using Adaptive Materials,"
- ⁸ Mei, Chuh and Gray, C.E., "A Finite Element Method for Large-Amplitude, Two-Dimensional Panel Flutter at Hypersonic Speeds," AIAA 30th Structures, Structural Dynamics, and Materials Conference, 1989.
- ⁹ Dowell, E.H., *Aeroelasticity of Plates and Shells*, Noordhoff International Publishing, Leyden, Netherlands, 1975.
- ¹⁰ Chen, W. and Lin, H., "Flutter Analysis of Thin Cracked Panels Using the Finite Element Method," *AIAA Journal*, Vol. 23, No. 5, May, 1985.
- ¹¹ Rogers, C.A., Liang, C., and Li, S., "Active Damage Control of Hybrid Materials Systems Using Induced Strain Actuators," AIAA 32nd Structures, Structural Dynamics and Materials Conference, Vol. 2, pp. 1190-1203, April, 1991.
- ¹² Dowell, E.H., "Fatigue Life Estimation of Fluttering Panels," *AIAA Journal*, Vol. 8, No. 10, October, 1970.
- ¹³ Xue, David Y. and Mei, Chuh, "Finite Element Nonlinear Flutter and Fatigue Life of 2-D Panels with Temperature Effects," AIAA 32nd Structures, Structural Dynamics, and Materials Conference, 1991.
- ¹⁴ Lee, C.K. and Moon, F.C., "Modal Sensors and Actuators," *Transactions of the ASME*, Vol. 57, June, 1990.
- ¹⁵ Banks, H.T., Fang, W., Silcox, R.J., and Smith, R.C., "Approximation Methods for Control of Acoustic and Structural Models with Piezoceramic Actuators," ICASE Report No. 91-88, December, 1991.
- ¹⁶ Daubechies, I., "Orthonormal Bases of Compactly Supported Wavelets," *Communications on Pure and Applied Mathematics*, Vol. XLI, 1988, pp. 909-996.
- ¹⁷ Mallat, S. G., and S. Zhong, "Characterization of Signals from Multiscale Edges," *IEEE Transactions on Pattern Analysis and Machine Intelligence*, Vol. 14, No. 7, July 1992, pp. 710-732.
- ¹⁸ Wells, R. O., Jr., and X. Zhou, "Wavelet Interpolation and Approximate Solutions of Elliptic Partial Differential Equations," Technical Report 92-03, Rice University, Computational Mathematics Laboratory.
- ¹⁹ Beylkin, G., R. Coifman, and V. Rokhlin, "Fast Wavelet Transforms and Numerical Algorithms I," *Communications on Pure and Applied Mathematics*, Vol. XLIV, 1991, pp. 141-183.
- ²¹ Resnikoff, H. L., "Wavelets and Adaptive Signal Processing," Technical Report AD910805, Aware Inc., 1991.
- ²² Ko, J. and Kurdila, A.J., "Connection Coefficient Truncation Error and Wavelet Differentiation," Center for Mechanics and Control, Texas A&M University, Technical Report No. CMC-93-02, 1993.
- ²³ Latto, A., H. L. Resnikoff, and E. Tenenbaum, "The Evaluation of Connection Coefficients of Compactly Supported Wavelets," Technical Report AD910708, Aware Inc., 1991.
- ²⁴ Beylkin, G., "On the Representation of Operators in Bases of Compactly Supported Wavelets"
- ²⁵ Brislawn, C., and I. G. Rosen, "Wavelet Based Approximation in the Control of Distributed Parameter Systems," *Numerical Functional Analysis and Optimization*, Vol. 12, 1991, pp. 33-77.
- ²⁶ Strang, G., "Wavelets and Dilation Equations : A Brief Introduction," *SIAM Review*, Vol. 31, No. 4, December 1989, pp. 614-627.
- ²⁷ Kim, Y.I. and Strganac, T.W., "Aeroelastic Stability of Damages Composite Structures," AIAA 33rd Structures, Structural Dynamics and Materials Conference, AIAA Paper 92-2392, April, 1992.

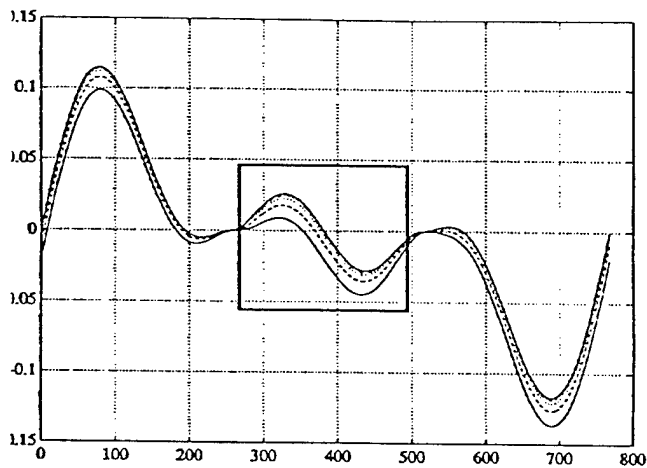

Figure (1) : Full Domain,
Clamped Plate Solution

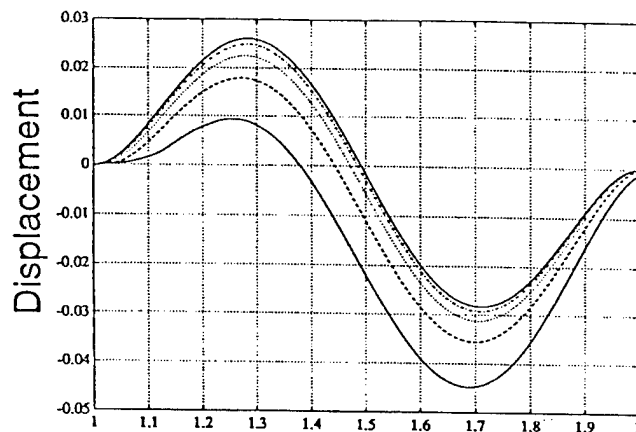

Figure (2) : Embedded Domain,
Clamped Plate Solution

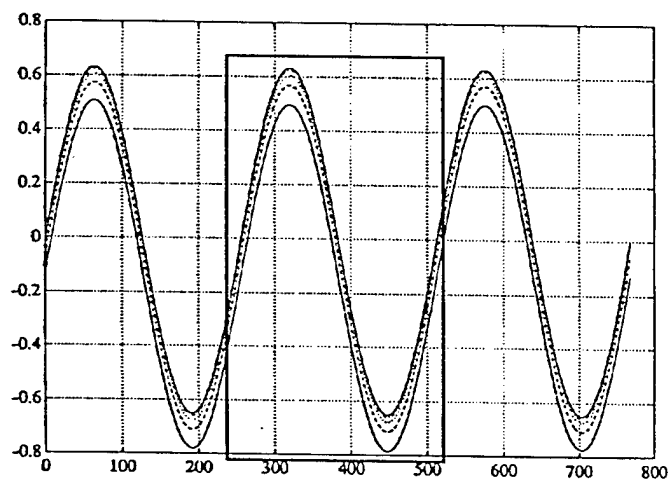

Figure (3) : Full Domain,
Simply Supported Plate Solution

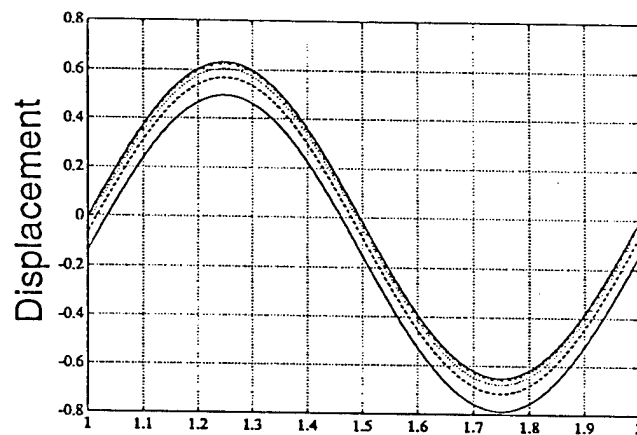

Figure (4) : Embedded Domain,
Simply Supported Plate Solution

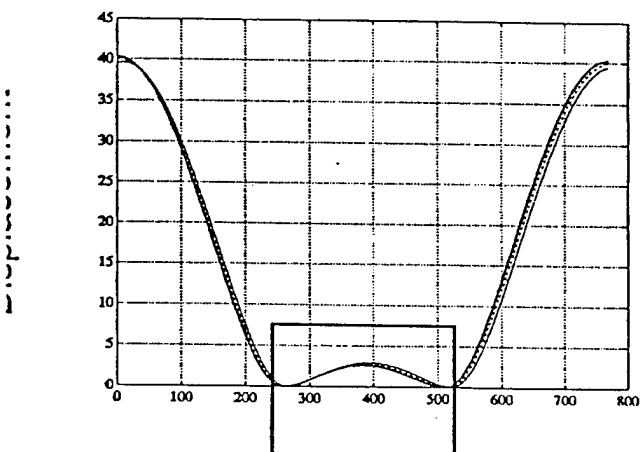

Figure (5) : Full Domain,
Clamped Plate Solution

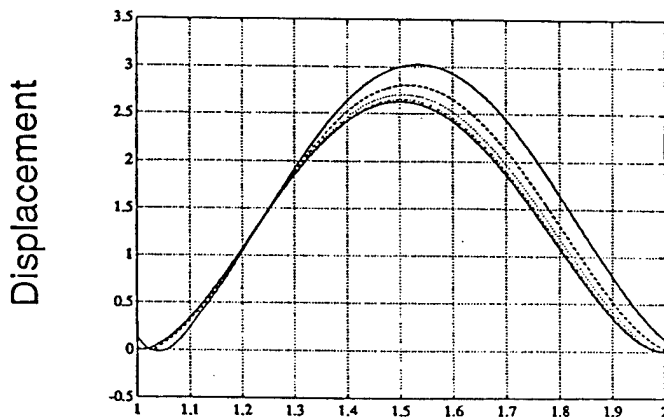

Figure (6) : Embedded Domain,
Clamped Plate Solution

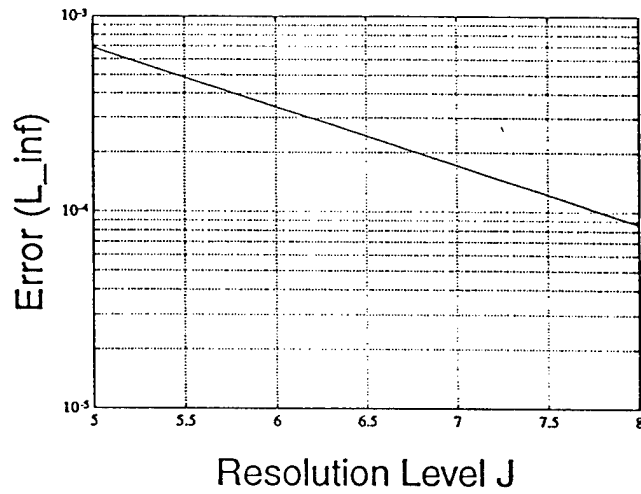

Figure (7) Asymptotic Convergence Rate, Clamped Plate 1

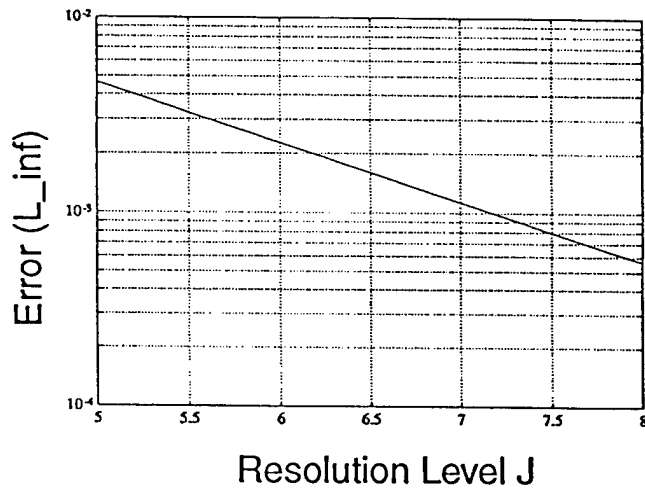

Figure (8) Asymptotic Convergence Rate, Hinged Plate 1

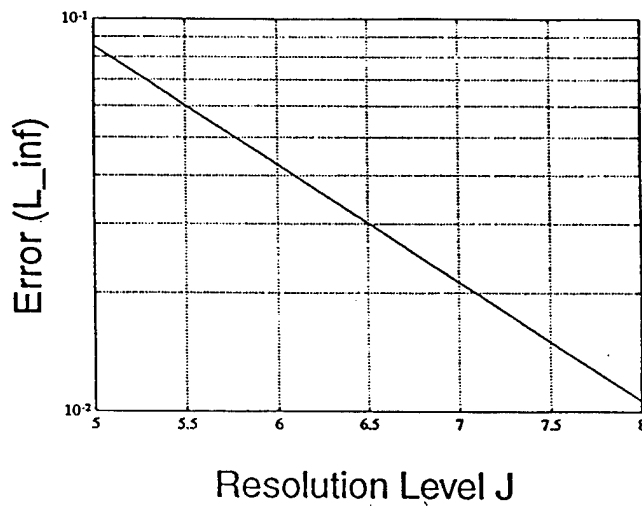

Figure (9) Asymptotic Convergence Rate, Clamped Plate 2

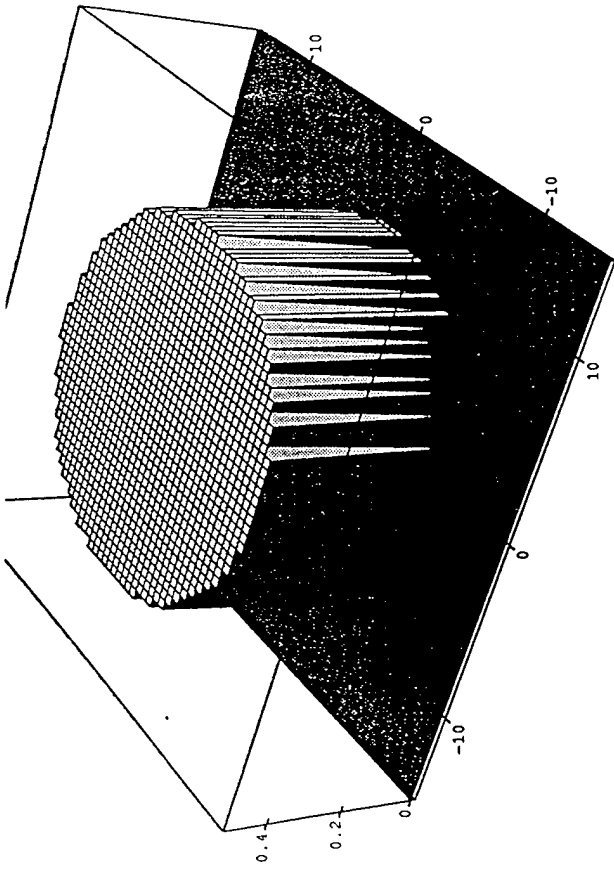

Figure (10) Characteristic Function, Circle

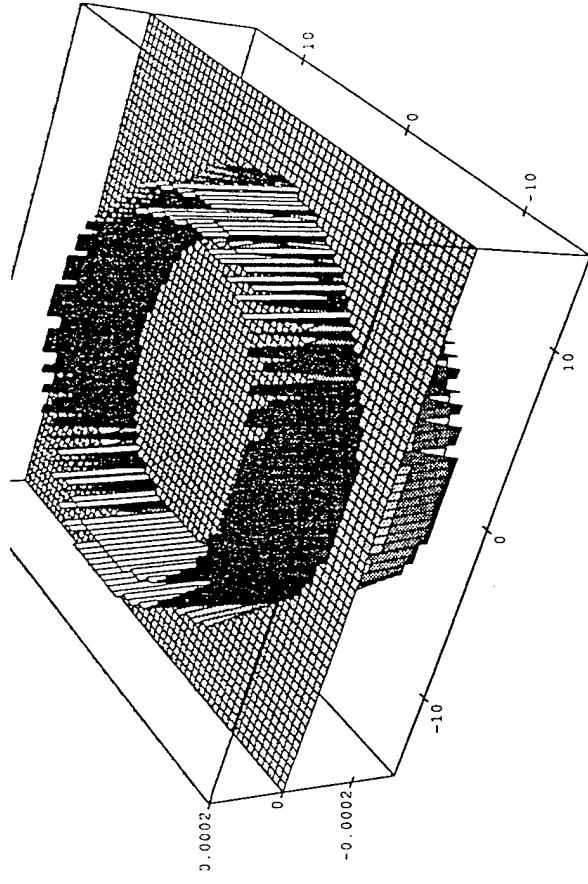

Figure (11) Boundary Measure, Circle

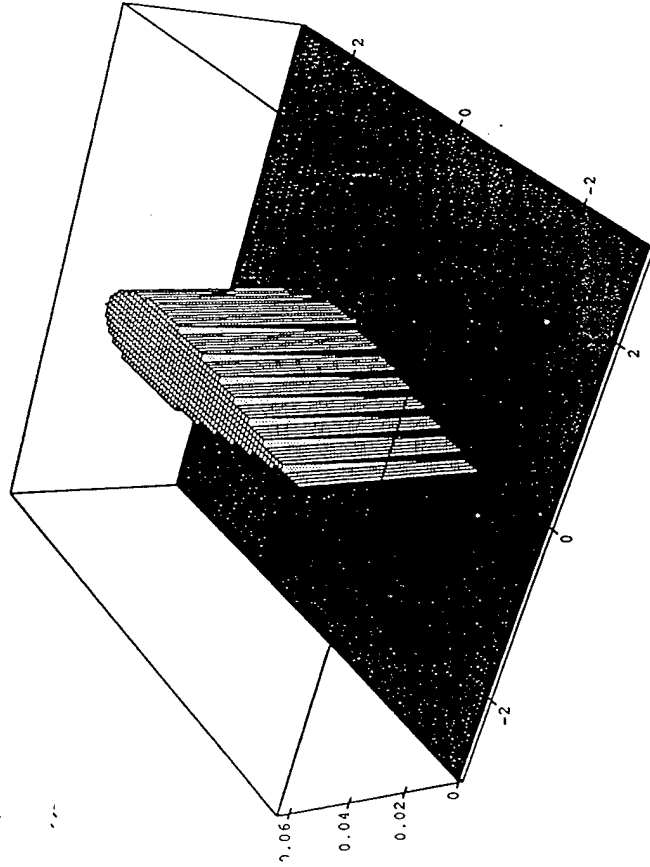

Figure (12) Characteristic Function, Airfoil

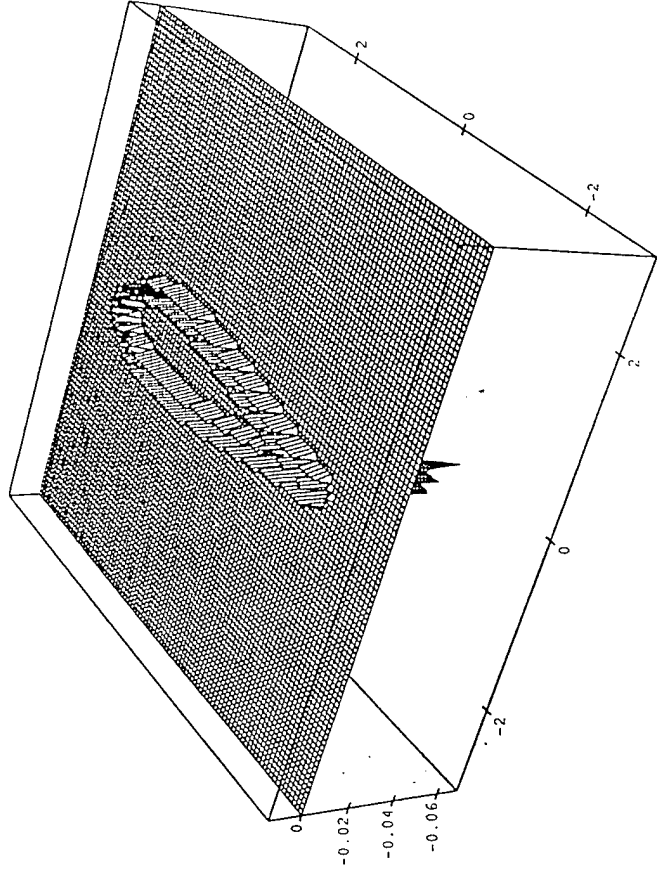

Figure (13) Boundary Measure, Airfoil

Table (1) Approximated Arclength for Circle $x^2 + y^2 = 100$

Level	Exact Length	Approximated Length	Error
$j = 0$	62.8319	62.812821	-0.030295 %
$j = 1$	62.8319	62.815614	-0.0258435 %
$j = 2$	62.8319	62.809639	-0.0353548 %
$j = 3$	62.8319	62.842482	+0.0169165 %
$j = 4$	62.8319	62.831550	-0.0005570 %

Attachment(2)

(2) *Nonlinear Flutter of Composite Plates with Damage Evolution*, Y. Kim, T.Strganac and A.Kurdila, AIAA-93-1546.



AIAA 93-1546

**Nonlinear Flutter of Composite Plates
with Damage Evolution**

*Young Ik Kim, Thomas W. Strganac,
and Andrew J. Kurdila*

*Texas A&M University
College Station, Texas*

**34th
AIAA/ASME/ASCE/AHS/ASC
Structures, Structural Dynamics and
Materials Conference
AIAA/ASME
Adaptive Structures Forum
April 19-22, 1993 / La Jolla, CA**

NONLINEAR FLUTTER OF COMPOSITE PLATES WITH DAMAGE EVOLUTION

*Young Ik Kim**, *Thomas W. Strganac***, and *Andrew J. Kurdila***

*Department of Aerospace Engineering
Texas A & M University
College Station, Texas*

ABSTRACT

The investigators present a study of dynamic and aeroelastic response of structures which evolve due to damage. Aeroelastic response is shown to be dependent upon the distribution and accumulation of damage. In turn, the damage is dependent upon the presence of the aerodynamic loads. Dynamic characteristics are unique to the coupled damage / aeroelastic system and are developed as part of the solution methodology. In this study, the damage is due to the natural progression of microcracking of the composite structure; yet, the control model presented is appropriate for distributed actuation systems. The stability boundary for aeroelastic flutter and divergence evolves due to damage. Control design based upon the min-max control theory is presented which addresses model uncertainties.

INTRODUCTION

Aeroelasticity is defined as the phenomenon resulting from the interaction between aerodynamic, inertial, and structural forces. A distinguishing characteristic of aeroelasticity is the presence of time dependent and displacement dependent aerodynamic loads. Traditionally, the elastic forces of the structure are assumed linear and the stiffness of the structure is assumed to remain constant for the life of the structure. However, these assumptions are not valid for structures which incorporate composite or active materials. Of particular interest in our research is the change in the aeroelastic stability due to the evolving structure. This evolution is the result of natural degradation of the structure due to a naturally-occurring progression of damage. This damage accumulation is dependent upon the history of the aerodynamic loads and the resulting deformations;

yet, these aerodynamic loads are dependent upon the increased flexibility of the structure.

The investigators examine the effect of damage accumulation in aeroelastic structures and elucidates the unique behavior of the dynamics for the evolutionary structure. The primary goal of the research includes the development of the fluid-structure model with structural evolution. The model permits the examination of dynamic response and aeroelastic stability characteristics of the evolving system, as well as damage detection and system identification.

The concept of actively suppressing dynamic or aeroelastic response by using smart materials is being pursued by several researchers. Control theory is required which is insensitive to partial loss of distributed actuation systems, classes of unmodelled damage effects, evolution of the material constitutive laws, or unmodelled nonlinear aerodynamic influences. Hence, another goal is the development of control theory for the evolutionary structure; these activities are addressed in a related paper.

A method has been developed to treat the interaction of aerodynamic forces, dynamics of the structure, and damage accumulation. Presently, the method is developed for the specific case of panel flutter. Panel flutter is defined as self-excited oscillatory motion caused when panels are exposed to high-speed airflow on one side of the structure (see Figure 1).^{1,2} Few researchers have examined the effects of evolution on aeroelastic phenomena.

Dowell briefly described the change in the aeroelastic stability arising from the degradation of the isotropic panel structure.³ Dowell suggested that nonlinear flutter analysis would permit the prediction of the fatigue life of the associated panel structure. Dowell further suggested that conventional fatigue data could be used for estimating the fatigue life of the panel structure specifically at flutter conditions. Xue,

* Graduate Research Assistant, Member AIAA

** Associate Professor, Senior Member AIAA

The governing equations for the linear aeroelastic behavior of the plate become

$$\rho h [\bar{M}] \{\dot{w}\} + g^* [\bar{C}_A] \{\dot{w}\} + [[\bar{K}] + \lambda^* [\bar{K}_A]] \{w\} = 0$$

where ρ is the density of the material, and h is the plate thickness. We also introduce the parameters $\lambda^* = \frac{2q}{\sqrt{M^2-1}}$ and $g^* = \lambda^* \frac{1}{U_\infty} \frac{(M^2-2)}{(M^2-1)}$ for convenience.

The matrices $[\bar{C}_A]$ and $[\bar{K}_A]$ represent unsteady aerodynamic contributions.

We assume a solution for these equations of the form $\{w\} = \{\bar{w}\} e^{\Omega t}$, where $\Omega = \delta + i\omega$. The equations are written in nondimensional form as

$$[[K] + \lambda[K_A] - \kappa[M]] \{\bar{w}\} = 0$$

where

$\lambda = \frac{a^3}{D_R} \lambda^*$, a = plate length, D_R = reference stiffness, $K_A = \frac{D_R}{a^3} \bar{K}_A$, and $K = \bar{K}$. The eigenvalue is defined as $\kappa = -\left(\frac{\Omega}{\omega_0}\right)^2 - g_a \left(\frac{\Omega}{\omega_0}\right)$, where $\omega_0 = \sqrt{\frac{D_R}{\rho h a^4}}$, $g_a = \sqrt{\frac{\lambda \mu}{M}}$, and $\mu = \frac{\rho_{air} a}{\rho h}$ for the case $M \gg 1$. The eigenvalues are complex and dependent upon flow conditions. The matrix $[K]$ includes the effect of damage and is dependent upon the prior load history.

Damage Model for the Structure

Composite materials are used for aircraft and spacecraft applications. The ability for composite materials to provide lightweight, response-tailored structures has been well documented. Adversely, microstructural damage is both inherent and unavoidable in these materials. Sources of damage include matrix cracking, delamination, fiber breakage, or fiber-matrix debonding. As a consequence, the research to characterize this damage has been quite active resulting in several analytically and experimentally based damage models.

We use a continuum mechanics approach for the damage model. This method follows the general formulation given by Coleman and Gurtin as described in their work on thermodynamics with internal state variables (ISV).⁷ The method proceeds from the assumption that ISVs can be implemented to describe the state of damage. Damage effects are introduced at the ply level; thus, the ISV method is independent of ply stacking sequence. An important characteristic of

the ISV approach is that an elastic medium with damage is treated as an equivalent homogeneous material.

The damage-dependent stiffness components ($[A']$, $[B']$, and $[D']$) are described in terms of the damage-dependent, angle-ply stiffness, $[\bar{Q}']$.⁸ Talerja defines a parameter, ξ , to describe damage within $[\bar{Q}']$. The stiffness of the composite laminate with damage is found as

$$(A'_{ij}, B'_{ij}, D'_{ij}) = \int \bar{Q}'_{ij}(1, z, z^2) dz$$

where

$$\bar{Q}'_{ij} = \bar{Q}_{ij} [E_1(\xi), E_2(\xi), \nu_{12}(\xi), G_{12}(\xi)]$$

The properties for the principal directions of a lamina are given by

$$E_1 = E_1^0 + 2\xi(C_3 + C_8(\nu_{12}^0)^2 - C_{16}\nu_{12}^0)$$

$$E_2 = E_2^0 + 2\xi(C_8 + C_3(\nu_{21}^0) - C_{16}\nu_{21}^0)$$

$$\nu_{12} = \nu_{12}^0 + \xi\left(\frac{1-\nu_{12}^0\nu_{21}^0}{E_2^0}\right)(C_{16} - 2C_8\nu_{12}^0)$$

$$G_{12} = G_{12}^0 + 2\xi C_{13}$$

where E_1^0 , E_2^0 , ν_{12}^0 , and G_{12}^0 are properties of the undamaged lamina. C_3 , C_8 , C_{13} , and C_{16} are constants phenomenological in nature. The damage parameter ξ represents the crack density, the magnitude of which is subject to a damage growth law.

The damage growth model incorporates the efforts of Allen, et al and Talreja.⁹⁻¹⁴

$$\dot{\alpha}_{mn}^p = \Omega_{mn}^p(\epsilon_{kl}, T, \alpha_{kl}^q)$$

where α_{mn}^p is the set of p ISVs, ϵ_{kl} is the strain, T is the temperature, and the overdot represents the derivative with respect to time.

The ISVs are defined as

$$\alpha_{ij} = \frac{1}{V_L} \int_S u_i n_j dS$$

where α_{ij} are components of the ISVs, V_L is the local volume in which homogeneity is assumed; u_i is the crack-face displacement, and n_j is the normal.

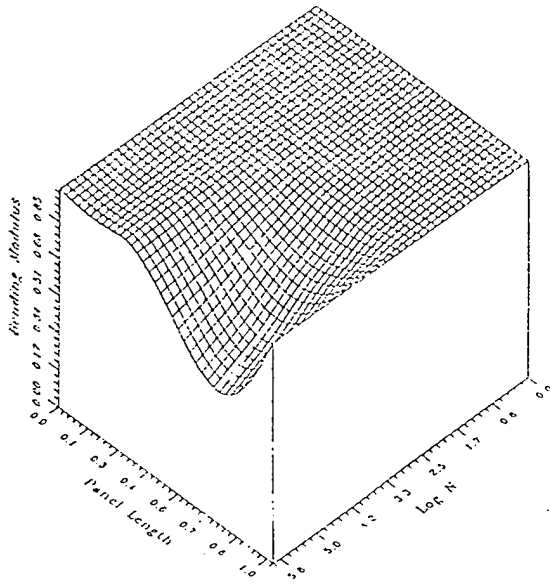

Fig.3 The evolution of stiffness for the aeroelastic structure.

use of adaptive control strategies. Adaptive control is imperative for models such as those described herein. The basis for this control strategy will be an extension of the adaptive Hamiltonian control theory.

Although some efforts have been made to derive active control strategies for aeroelastic structures using smart materials, this research is in the early stage of development. The authors are aware of

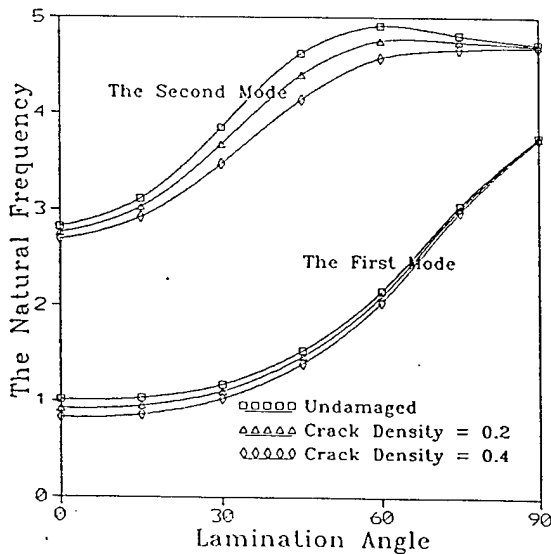

Fig. 4. The natural frequencies of a composite plate with the progression of microstructural damage.

no research that treats the fundamental issue of robustness of control design with respect to actuator degradation expected during routine operation, let alone the possibility of sensor or actuator failure. While numerous research papers on the use of smart materials for active control are available, the works of Scott and Rogers are particularly pertinent.^{16,17} In Scott, an LQR strategy is employed to design piezoelectric controls to reduce panel flutter and raise the value of dynamic pressure associated with flutter. The analytical results are extremely promising. On the other hand, the work of Rogers uses shape memory alloys to reduce crack growth in composites. One potential drawback with the approach taken by Scott is that the LQR design strategy does not account a priori for injected disturbances or material change which will develop in fatigue or damage. Likewise, Rogers clearly demonstrates that shape memory alloys have the potential to significantly reduce local stress concentrations; however, an active control strategy based upon some optimality principle does not exist. Furthermore, the approach in Rogers' work deals with degradation of the composite laminate while the integrity of the control is unaffected.

The design of control strategies for the aeroelastic model with damage accumulation can be interpreted as a two player game. The simplest explanation is achieved by examining the prior governing equations but including control. In this case, the two right hand side terms have "adversarial" roles,

$$[M]\{\ddot{w}\} + [C]\{\dot{w}\} + [\bar{k}]\{w\} = [[K_D] + [A]]\{w\} + [B]\{u\}$$

The stiffness damage and aeroelastic terms, $[[K_D] + [A]]$, tend to destabilize the system, while the control terms, $[B]$, are selected to offset this effect. The destabilizing terms represent localized damage from microcracking or delamination, actuation loss, unmodelled disturbances, or unmodelled nonlinear effects.

The investigators have extended the above rudimentary model to account for distributed parameter, or infinite dimensional, models of system dynamics for classes of disturbances and uncertainty. A more detailed discussion of this approach can be found in related papers.^{18,19,20}

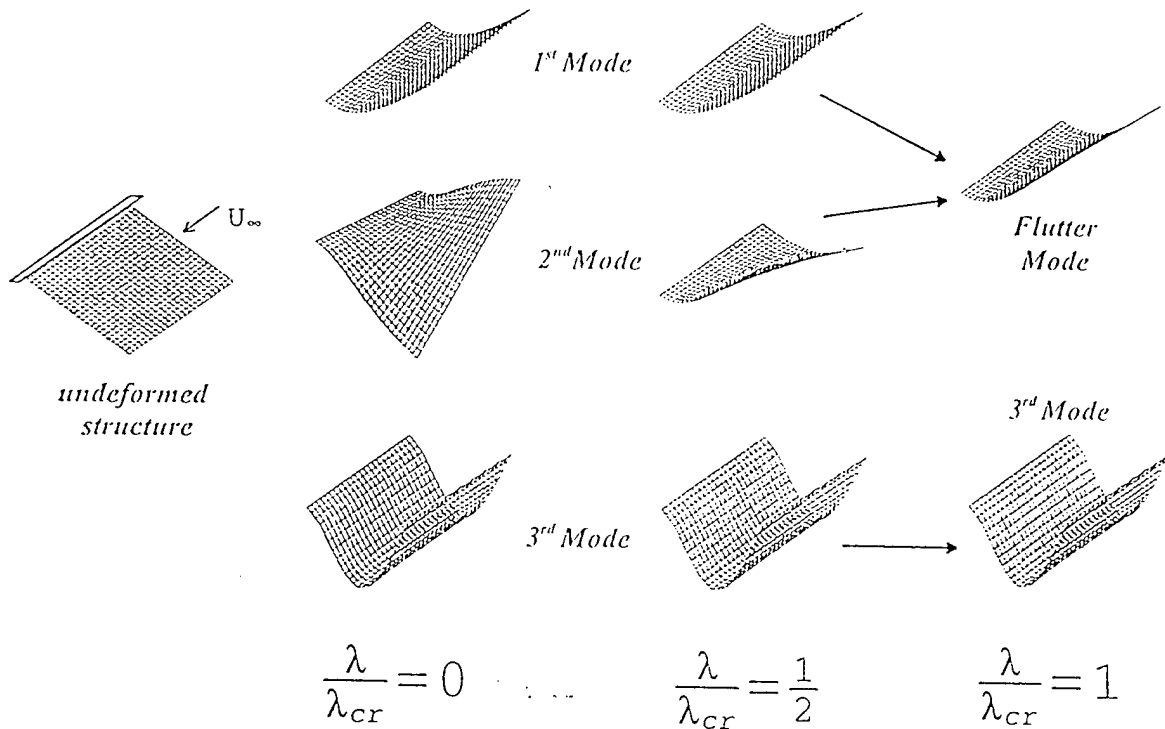

Fig. 6. The mode shapes of the cantilevered composite plate. Some modes are influenced by aerodynamic loads. The primary bending and twist mode coalesce to form the aeroelastic mode in first

Of particular interest is the reduction in the critical dynamic pressure for the case of damage growth due to the stress field, but the increase in the critical dynamic pressure for the case of uniform damage.

The mode shapes of the aeroelastic structure are dependent upon the dynamic pressure. The first three mode shapes are shown in figure 6 for increasing flow conditions. At flutter, the first two modes coalesce to form a single aeroelastic mode. The third mode is not influenced at these conditions. Although the frequencies show a significant change due to damage, the differences in the mode shapes due to damage are not remarkable.

The aeroelastic boundary is dependent upon damage and fiber orientation. The aeroelastic stability boundary is presented in fig. 7 for several orientations. Uniform damage is assumed to illustrate the effect of damage on this boundary. The minimum boundary is presented: the structure is limited by flutter for certain fiber orientations fiber angles; the structure is limited by divergence for other fiber orientations. Damage has a significant effect on the stability boundary.

Damage is not uniformly distributed; rather, the distribution is dependent upon the stress field which is not symmetric due to the presence of aerodynamic loads. The stress distribution for the composite lamina

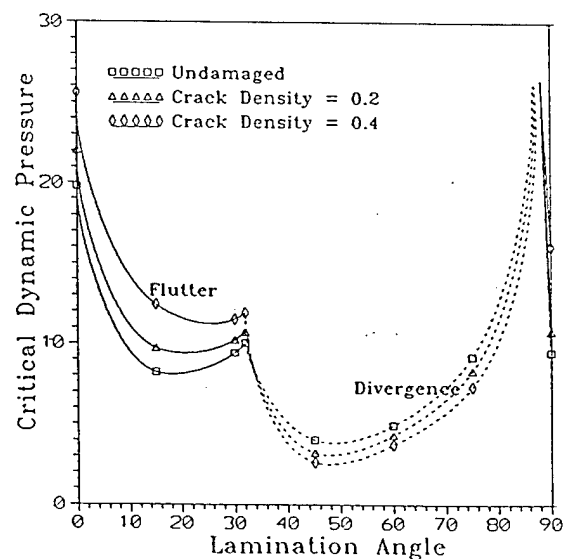

Fig. 7. The aeroelastic boundary for the composite structure. Flutter and divergence depend upon the lamina orientation and microstructural damage.

- ⁷ Coleman, B.D. and Gurtin, M.E., "Thermodynamics with Internal State Variables", *Journal of Chemical Physics*, Vol.47, 1967.
- ⁸ Sanders, D.R., Kim, Y.I., and Stubbs, N., "Nondestructive Evaluation of Damage in Composite Structures using Modal Parameters", *Experimental Mechanics*, September, 1992.
- ⁹ Allen, D.H., Harris, C.E. and Groves, S.E., "A Thermomechanical Constitutive Theory for Elastic Composites with Distributed Damage. Part I: Theoretical Development", *International Journal of Solids and Structures*, Vol.23, No.9, 1987.
- ¹⁰ Allen, D.H., Harris, C.E. and Groves, S.E., "A Thermomechanical Constitutive Theory for Elastic Composites with Distributed Damage. Part II: Application to Matrix Cracking in Laminated Composites", *International Solids and Structures*, Vol.23, No.9, 1987.
- ¹¹ Allen, D.H., Groves, S.E., and Harris, C.E., "A Cumulative Damage Model for Continuous Fiber Composite Laminates with Matrix Cracking and Interply Delaminations", *Composite Materials: Testing and Design* (8th Conference), ASTM STP, American Society for Testing and Materials, 1987.
- ¹² Harris, C.E. and Allen, D.H., "A Continuum Damage Model for Laminated Composite", *SAMPE Journal*, Vol.24, 1988.
- ¹³ Talreja, R., "A Continuum Mechanics Characterization of Damage in Composite Materials", *Proceedings of The Royal Society London*, Vol. A399, 1985.
- ¹⁴ Talreja, R., "Stiffness Properties of Composite Laminates with Matrix Cracking and Interior Delamination", *Engineering Fracture Mechanics*, Vols. 5-6., 1986.
- ¹⁵ Lo, D.C., Allen, D.H., and Harris, C.E., "A Continuum Model for Damage Evolution in Laminated Composites", *Inelastic Deformations of Composite Materials*, G.J. Dvorak, Ed. Springer-Verlag, 1990.
- ¹⁶ Scott, R.C. and Weisshaar, T.A., Controlling Panel Flutter Using Adaptive Materials,
- ¹⁷ Rogers, C.A., Liang, C., and Li, S., Active Damage Control of Hybrid Materials Systems Using Induced Strain Actuator, AIAA 32nd Structures, Structural Dynamics and Materials Conference, Vol. 2, pp 1190-1203, April 1991.
- ¹⁸ Kurdila, A.J., Fabiano, R., Strganac, T.W., and Hsu, S., Semigroup Approximation and Robust Stabilization of Distributed Parameter Systems, NASA Workshop on Distributed Parameter Modelling and Control of Flexible Aerospace Systems, NASA Langley Research Center, June 1992.
- ¹⁹ Ko, J., Kim, C., Kurdila, A.J., and Strganac, T.W., Wavelet Galerkin Methods for Game Theoretic Control of Distributed Parameter Systems, AIAA 34th Structures, Structural Dynamics, and Materials Conference, AIAA Paper No. 93-1674, April 1993.
- ²⁰ Fabiano, R.H., Kurdila, A.J., and Strganac, T.W., Robust Control of Distributed Parameter Systems with Structural Uncertainty, Proceedings of the Conference on Computation and Control III, Progress in Systems and Control Theory, K. Bowers and J. Lund, Ed., 1992.
- ²¹ Kim, Y.I. and Strganac, T.W., Aeroelastic Stability of Damaged Composite Structures, AIAA 33rd Structures, Structural Dynamics and Materials Conference, AIAA Paper 92-2392, April 1992.

Attachment (3)

(3) *Wavelet-Galerkin Methods for Game Theoretic Control of Distributed Parameter Systems*,
A.Kurdila and J.Ko, AIAA-93-1674

Wavelet Galerkin Methods for Game
Theoretic Control of Distributed
Parameter Systems

Jeonghwan Ko* , Cheolho Kim* , Andrew J. Kurdila†, and Thomas W. Strganac‡

Center for Mechanics and Control
Department of Aerospace Engineering
Texas A&M University
College Station, Texas 77843-3141

Abstract

This paper presents a novel strategy for obtaining finite dimensional approximations of Riccati operators arising in game theoretic control problems on Hilbert spaces. While extensive progress has been made in the utilization of the newly developed field of wavelet analysis in signal and image processing, for less progress has been made in application to computational mechanics. This fact is surprising considering the inherent multiresolution properties of wavelet analysis. This paper derives a wavelet galerkin formulation of a specific class of computational control problems: zero sum dynamic games on Hilbert spaces. This work extends previous research in that not only are convergence, exponential stability and robust stability of soft constrained differential games on Hilbert spaces considered, but quantitative numerical conditioning results are also presented. In fact, a precise bound is given on the error induced by truncating wavelet quadratures used in the weak formulation of computational control problems. The theory presented is verified by modeling a robust control strategy for a beam subjected to piezoceramic actuation and structured uncertainty.

Nomenclature

$\{h_0, \dots, h_{2N-1}\}$ Daubechies coefficients set for scaling function

The research in this paper has been supported in part by AFOSR grant F49620-92-J-0450 under the supervision of Dr. Spencer Wu, and the Institute for Scientific Computing at Texas A&M University.

Copyright ©1993 by the American Institute of Aeronautics and Astronautics, Inc. All rights reserved.

*Graduate Student, Department of Aerospace Engineering, Member AIAA.

†Assistant Professor, Department of Aerospace Engineering, Member AIAA.

‡Associate Professor, Department of Aerospace Engineering, Senior Member AIAA.

$\{b_0, \dots, b_{2N-1}\}$	Daubechies coefficients set for wavelet function
$\delta_{p,q}$	Kronecker delta function
$\phi(x)$	Scaling function
$\phi_k^j(x)$	Dilated and translated scaling function
$\psi_k^j(x)$	Dilated and translated wavelet function
N	Genus of the Daubechies wavelet system
c	First moment of Daubechies scaling function
p, q	Indices for translation
f	Any function in L_2
$\Lambda_{l_1, l_2}^{d_1, d_2}$	General connection coefficient
l_1, l_2	Indices for translation
d_1, d_2	Orders of differentiation
y	Displacement of beam
u	Control input
w	Disturbance input
Z	Integers
V_j	Multiresolution subspace
P_j	Outhogonal projection
C_k^j	Scaling basis coefficients
d_k^j	Wavelet basis coefficient
$A, \Delta A$	Infinitesimal generator, structured perturbation
$B, \Delta B$	Control influence, structured perturbation
J_0, J_1	Cost functional
H, H_n	(Hilbert) State space, approximating subspace
$H(x)$	Heaviside function
$H_i(x)$	Piezoceramic actuator distributions

ϵ_i Structured perturbation scaling
 δ_i Structured perturbation

Introduction

With the ground breaking work of ^{1,2}, wavelets and multiresolution analysis have become a predominant area of research in scientific computing. To a large extent, most work to date has focussed on image processing ^{3,4} and signal processing². Still the potential for major advances in computational techniques for partial differential equations¹ and integral equations⁵ have also been noted. Just as recently, the advantages of multiresolution analysis in certain applications in computational mechanics has been established^{6,7}.

In the computational mechanics area, the finite element method has become the standard by which other numerical techniques are measured. One general feature of the finite element method is that as the mesh size h becomes smaller, the resulting matrix of the algebraic equations has a condition number increasing at the rate of $(\frac{1}{h^p})$. This effect can result in very slow convergence rates when classes of iterative techniques are used to solve the resulting algebraic equations. On the other hand, ^{8,9} and ¹² have shown that the wavelet-based partial differential equation formulations yield a matrix which is proven to have a nearly constant condition number with simple diagonal preconditioning, independent from the mesh size. When one considers its rapid convergence properties and the relatively simple computational implementation⁶, it is apparent that there is an enormous potential for significant development of wavelet-Galerkin methods in computational mechanics.

In order to solve differential equations of any type using a Galerkin method, one eventually needs the approximation of the derivative of some basis functions. If one uses a wavelet basis, such as the Daubechies wavelet system, this requires the calculation of connection coefficients having the form

$$\Lambda_k = \int \frac{d\phi}{dx}(x)\phi(x-k) dx$$

where ϕ is a wavelet scaling function. While the connection coefficients for some wavelet systems can be calculated in closed form ^{8,9}, ³, or to any prescribed accuracy using numerical techniques ¹⁰, truncated quadratures must be used in practice.

Wavelet Interpolation

In this paper Daubechies wavelets are employed exclusively, which are introduced in ¹. Let ϕ be the Daubechies scaling function of order N ($N\phi$ in ¹), and

let $\{h_0, h_1, \dots, h_{2N-1}\}$ be the corresponding coefficients for the 2-scale difference equation

$$\phi(x) = \sqrt{2} \sum_{k=0}^{2N-1} h_k \phi(2x-k), \quad \phi(x) \in L^2(\mathbb{R}) \quad (2.1)$$

The coefficients $\{h_0, h_1, \dots, h_{2N-1}\}$ satisfy

$$\sqrt{2} \sum_{k=0}^{2N-1} h_k = 2 \quad (2.2)$$

$$\sum_{k=0}^{2N-1} h_k h_{k+2l} = \delta_{0,l}, \quad l \in \mathbb{Z}$$

where $\delta_{l,m}$ is the Kronecker delta function. The coefficients $\{h_k\}$ for various N are given in ¹. By choosing

$$b_k := (-1)^{k+1} h_{2N-1-k} \quad (2.3)$$

[Daubechies] derives a compactly supported wavelet function $\psi(x)$ from the scaling function $\phi(x)$ via

$$\psi(x) = \sum_{k=0}^{2N-1} b_k \phi(2x-k), \quad \psi(x) \in L^2(\mathbb{R}) \quad (2.4)$$

Since the coefficients h_k 's are finite, the functions ϕ and ψ both have finite support in the interval $[0, 2N-1]$, and they are orthogonal to themselves and to each other.

One can define the wavelet system associated with ϕ by

$$\begin{aligned} \phi_k^j(x) &:= 2^{j/2} \phi(2^j x - k) \\ \psi_k^j(x) &:= 2^{j/2} \psi(2^j x - k) \end{aligned} \quad (2.5)$$

where $k \in \mathbb{Z}$, $j \in \mathbb{Z}^+$ (the nonnegative integers). Then the above functions have following properties :

$$\text{supp} \left(\phi_k^j(x), \psi_k^j(x) \right) = \left[\frac{k}{2^j}, \frac{k+2N-1}{2^j} \right]$$

$$\|\phi_k^j\|_{L^2(\mathbb{R})} = 1 \quad (2.6)$$

$$\sum_{k \in \mathbb{Z}} \phi_k^j(x) = 2^{j/2}, \quad x \in \mathbb{R}$$

$$\int_{\mathbb{R}} x^m \psi(x) dx = 0, \quad m = 0, \dots, N-1$$

Moreover $\phi, \psi \in C^{\alpha(N)}$ where, for example, $\alpha(2) \approx 0.55$, $\alpha(3) \approx 1.088$, $\alpha(4) \approx 1.618$. Due to the orthogonality of $\phi(x)$ and $\psi(x)$, the dilated and scaled wavelet system $\phi_k^j(x)$ and $\psi_k^j(x)$ also are orthonormal.

$$\begin{aligned} \int_{\mathbb{R}} \phi_k^j(x) \phi_m^l(x) dx &= \delta_{j,l} \cdot \delta_{k,m} \\ \int_{\mathbb{R}} \psi_k^j(x) \psi_m^l(x) dx &= \delta_{j,l} \cdot \delta_{k,m} \end{aligned} \quad (2.7)$$

If one defines

$$\begin{aligned} V_j &:= \text{clos}(\text{span}(\phi_k^j(x), k \in \mathbf{Z}, j \text{ fixed})) \quad (2.8) \\ W_j &:= \text{clos}(\text{span}(\psi_k^j(x), k \in \mathbf{Z}, j \text{ fixed})) \end{aligned}$$

one obtains a multiresolution analysis having the following properties :

- (i) $\dots \subset V_{n-1} \subset V_n \subset V_{n+1} \subset \dots$
- (ii) $\text{clos}_{L^2}(\cup_{n \in \mathbf{Z}} V_n) = L^2(\mathbf{R})$
- (iii) $\cap_{n \in \mathbf{Z}} V_n = 0$ (2.9)
- (iv) $V_n = V_{n-1} \oplus W_{n-1}$
- (v) $\oplus_{n \in \mathbf{Z}} W_n := \dots \oplus W_{-1} \oplus W_0 \oplus W_1 \oplus \dots = L^2(\mathbf{R})$

Let P_j denote the orthogonal projection $L^2(\mathbf{R}) \rightarrow V_j$. Then $P_j f$ converges to f in the L^2 norm,

$$\lim_{j \rightarrow \infty} P_j f = f \quad (2.10)$$

Let $f^j(x)$ be the projection of f onto V_j , i.e.

$$f^j(x) = P_j f, \quad f^j \in V_j \quad (2.11)$$

From the MRA (Multiresolution analysis) property (iv), $f^j(x)$ can be decomposed into two functions such that

$$f^j(x) = f^{j-1}(x) + g^{j-1}(x) \quad (2.12)$$

where

$$f^{j-1}(x) \in V_{j-1} \quad \text{and} \quad g^{j-1}(x) \in W_{j-1} \quad (2.13)$$

If one continues the decomposition M times

$$\begin{aligned} f^j(x) &= f^{j-M}(x) + g^{j-M}(x) \\ &\quad + g^{j-M+1}(x) + \dots + g^{j-1}(x) \end{aligned} \quad (2.14)$$

Since one can express $f^j(x)$ in terms of the scaling function, the above decomposition can be rewritten as

$$\begin{aligned} f^j(x) &= \sum_k c_k^j \phi_k^j(x) \\ &= \sum_k c_k^{j-1} \phi_k^{j-1}(x) + \sum_k d_k^{j-1} \psi_k^{j-1}(x) \quad (2.15) \\ &= \sum_k c_k^{j-M} \phi_k^{j-M}(x) + \sum_k d_k^{j-M} \psi_k^{j-M}(x) \\ &\quad + \dots + \sum_k d_k^{j-1} \psi_k^{j-1}(x) \end{aligned}$$

As a result, one can derive the relationships between the coefficients set c_k^j , and c_k^{j-1}, d_k^{j-1} ,

$$c_k^{j-1} = \frac{1}{\sqrt{2}} \sum_l c_l^j h_{l-2k} \quad (2.16)$$

$$d_k^{j-1} = \frac{1}{\sqrt{2}} \sum_l c_l^j b_{l-2k}$$

or, conversely

$$c_k^j = \frac{1}{\sqrt{2}} \sum_l \left(c_l^{j-1} h_{k-2l} + \sum_l d_l^{j-1} b_{k-2l} \right) \quad (2.17)$$

Approximations to the coefficients c_k^j to express the function $f^j(x)$ can be calculated using the following quadrature formula⁶

$$c_k^j = \frac{1}{2^{j/2}} f \left(\frac{k+c}{2^j} \right) \quad (2.18)$$

where c is some constant defined in the following theorem.

Theorem Assume the function $f \in C^2(\Omega)$, where Ω is a bounded open set in \mathbf{R}^2 . Let for $j \in \mathbf{N}$,

$$\begin{aligned} f^j(x, y) &:= \frac{1}{2^j} \sum_{p, q \in \Lambda} f \left(\frac{p+c}{2^j}, \frac{q+c}{2^j} \right) \phi_p^j(x) \phi_q^j(y), \\ &\quad x, y \in \Omega \end{aligned} \quad (2.19)$$

where the index set $\Lambda = \{i \in \mathbf{Z} : \text{supp}(\phi_i^j) \cap \Omega \neq \emptyset\}$ and $c := \int x \phi dx = \frac{\sqrt{2}}{2} \sum_{k=0}^{2N-1} k h_k$. Then

$$\|f - f^j\|_{L^2(\Omega)} \leq C(1/2^j)^2$$

and

$$\|f - f^j\|_{H^1(\Omega)} \leq C/2^j$$

where C is a constant depending only on the diameter of Ω , N , and the maximum modulus of the first and second order derivatives of f on Ω .

Wavelet Differentiation

A critical feature and advantage of employing a wavelet-Galerkin basis in applications to computational mechanics is that explicit formulae can be derived for classes of differential operators of the connection coefficients discussed earlier. Techniques to accomplish this representation are discussed in ^{11, 8, 9, 5}. The approach taken in this paper employs translations and dilations of the scaling function only as in ⁶, as opposed to using the associated wavelet bases themselves. As in the last section, if a function $f(x)$ has the approximate representation $f^j(x)$,

$$f^j(x) = \sum_{p \in \Lambda} f_p^j \phi_p^j(x) \quad (3.1)$$

then one can differentiate this expression to achieve

$$\frac{df^j}{dx}(x) = \sum_{p \in \Lambda} f_p^j \frac{d}{dx} (\phi_p^j(x)) \quad (3.2)$$

Consequently, the solution for the derivative of $f^j(x)$ reduces to the calculation of

$$\frac{d}{dx} (\phi_p^j(x)) \quad \text{for all } p \in N \quad (3.3)$$

However, one can always expand the derivative in form of the basis functions

$$\frac{d}{dx} (\phi_p^j(x)) = \sum_k \alpha_{k,p} \phi_k^j(x) \quad (3.4)$$

Taking the L^2 -inner product of the above equation with an arbitrary basis function $\phi_r^j(x)$, one finds that

$$\alpha_{r,p} = \int \frac{d}{dx} (\phi_p^j(x)) \phi_r^j(x) dx \quad (3.5)$$

By a change of variables one can show that

$$\alpha_{r,p} = 2^j \int \frac{d\phi}{d\xi}(\xi) \phi(\xi + r - p) d\xi, \quad \xi = 2^j x + p \quad (3.6)$$

This equation is one example of the general two-term coefficients defined by ¹¹

$$\Lambda_{l_1, l_2}^{d_1, d_2} = \int \frac{d^{d_1}}{dx^{d_1}} \phi(x - l_1) \frac{d^{d_2}}{dx^{d_2}} (\phi(x - l_2)) dx \quad (3.7)$$

In particular,

$$\alpha_{r,p} = 2^j \Lambda_{0, p-r}^{1,0} \quad (3.8)$$

so that the final expression for the derivative of $f^j(x)$ becomes

$$\begin{aligned} \frac{df^j}{dx}(x) &= \sum_{p \in \Lambda} f_p^j \sum_r 2^j \Lambda_{0, p-r}^{1,0} \phi_r^j(x) \\ &= \sum_{p \in \Lambda} \sum_r 2^j f_p^j \Lambda_{0, p-r}^{1,0} \phi_r^j(x) \end{aligned} \quad (3.9)$$

It is important to note that these connection coefficients can be calculated once, stored in a program and used repeatedly. Detailed discussions of their calculation can be found in ^{11, 10}, and ⁵. Symbolic manipulation programs to calculate these coefficients to arbitrary order have been developed by the author.

Game Theoretic Control

As noted earlier, an enormous literature has accumulated over the past ten years regarding the convergence of finite dimensional approximations to the infinite dimensional linear quadratic regulator problem.

This problem is formulated by considering the abstract Cauchy problem on a Hilbert space H

$$\begin{aligned} \dot{x}(t) &= Ax(t) + Bu(t) \\ x(0) &= x_0. \end{aligned} \quad (4.1)$$

where U is a Hilbert space, $B \in L(U, H)$ and A is the infinitesimal generator of a strongly continuous semigroup $T(t)$ on H . By defining the cost functional

$$J_0(u) = \int_0^\infty \{ |Cx(t)|_H^2 + \langle Ru, u \rangle \} dt, \quad (4.2)$$

where $C \in L(H, H)$ and R is a positive definite selfadjoint bounded operator on U , the LQR problem is to find $u^0 \in \bar{U} = L^2(0, \infty; U)$ such that

$$J_0(u^0) = \inf_{u \in \bar{U}} J_0(u) \quad (4.3)$$

subject the equations of dynamics. However, the formulation in equations (4.1) and (4.2) does not account for any exogeneous disturbance, or uncertainty, in the model. To obtain a theory that makes provision for disturbance attenuation and uncertainty for infinite dimensional models, the authors have extended certain results from finite dimensional H^∞ / game theoretic control and approximation theory for the LQR problem in equations (4.1) and (4.2) ^{17, 18, 19}.

The theory presented in ^{17, 18, 19} considers the abstract Cauchy problem

$$\begin{aligned} \dot{x}(t) &= (A + \Delta A)x(t) + (B + \Delta B)u(t) \\ x(0) &= x_0, \end{aligned} \quad (4.4)$$

where $\Delta A \in L(H, H)$ and $\Delta B \in L(U, H)$ are bounded linear operators representing the structured uncertainty in the model and the control system. Kurdila ¹⁹ and Fabiano ¹⁹ extend the finite dimensional results in ²² by assuming that one can factor the perturbations ΔA and ΔB as

$$\begin{aligned} \Delta A &= DL_A E \\ \Delta B &= FL_B G \end{aligned} \quad (4.5)$$

where $D, E \in L(H, H)$, $F \in L(U, H)$, $G \in L(U, U)$ are known, and $L_A \in L(H, H)$, $L_B \in L(U, U)$ are unknown. The robust stability result in ²⁰ and ¹⁷ can be derived by introducing the fictitious disturbances

$$\begin{aligned} w_1 &= L_A y_1 \\ w_2 &= L_B y_2 \end{aligned} \quad (4.6)$$

and associated observations

$$\begin{aligned} y_1 &= Ex \\ y_2 &= Gu. \end{aligned} \quad (4.7)$$

These equations can be expressed more compactly by letting $w = (w_1, w_2) \in H \times H$ and $y = (y_1, y_2) \in H \times U$. In this case

$$w = \begin{bmatrix} L_A & 0 \\ 0 & L_B \end{bmatrix} y \quad (4.8)$$

From these definitions, the system model with structured uncertainty can be interpreted as a form of the original system with injected disturbance and can be written as

$$\begin{aligned} \dot{x}(t) &= Ax(t) + Bu(t) + \Gamma w(t) \\ x(0) &= x_0. \end{aligned} \quad (4.9)$$

Here $\Gamma \in L(H \times H, H)$ is defined by $\Gamma(w_1, w_2) = Dw_1 + Fw_2$. As noted in ¹⁷, (4.9) can be treated in the differential game framework by considering the cost

$$\begin{aligned} J_1(u, w) &= \int_0^\infty \left\{ |Cx|_H^2 + \langle Ru, u \rangle_U \right. \\ &\quad \left. + |y|_{H \times U}^2 - \frac{1}{\gamma^2} |w|_{H \times H}^2 \right\} dt \\ &= \int_0^\infty \left\{ \langle Qx, x \rangle_H + \langle \hat{R}u, u \rangle_U \right. \\ &\quad \left. - \frac{1}{\gamma^2} |w|_W^2 \right\} dt, \end{aligned} \quad (4.10)$$

where $Q = C^*C + E^*E$, $\hat{R} = R + G^*G$, and $W = H \times H$. With this soft-constrained linear quadratic dynamic game, one can associate the Hilbert space counterpart of the well known finite dimensional Riccati equation ²⁴

$$A^*\Pi + \Pi A + Q - \Pi(B\hat{R}^{-1}B^* - \gamma^2\Phi\Phi^*)\Pi = 0. \quad (4.11)$$

Reference ¹⁹ derives the following result extending to infinite dimensional systems the robust stability theorem proven in ²².

Theorem 2.2 Suppose that (C, A) is detectable. If Π is a nonnegative definite solution of (4.11), then the feedback control $u(t) = -\hat{R}^{-1}B^*\Pi x(t)$ stabilizes (4.4) for all $|L_A| < \gamma$, $|L_B| < \gamma$.

As pointed out in ¹⁹ the result in ²² requires that (Q, A) be detectable, while this result only requires that (C, A) be detectable.

In some applications, such as the one considered in ¹⁹ and in the next section, standard results on the convergence of approximations to the infinite dimensional LQR problem [e.g. ¹⁵, ¹⁴] can be applied to approximate the game theoretic control problem discussed above. Let $\{H_n\}_{n=1}^\infty$ be a family of finite dimensional approximating subspaces of H such that

$$H = \overline{\bigcup_{n=1}^\infty H_n}$$

and suppose that $A_n \in L(H_n, H_n)$, $\Omega \in L(H, H_n)$, and $Q_n \in L(H_n, H_n)$, while P_n is the orthogonal projection

onto H_n . The n th approximating algebraic Riccati equation can be written as an operator equation on H_n

$$A_n^*\Pi_n + A_n\Pi_n - \Pi_n\Omega_n\Omega_n\Pi_n + Q_n = 0$$

The following theorem is derived in ¹⁹

Theorem 2.3 Suppose that for each $x \in H$ one has

$$(i) T_n(t)P_n x \rightarrow T(t)x \quad \text{and} \quad T_n^*(t)P_n x \rightarrow T^*(t)x$$

$$(ii) \Omega_n x \rightarrow \Omega x \quad \text{and} \quad \Omega_n^* P_n x \rightarrow \Omega^* x$$

(iii) $Q_n P_n x \rightarrow Qx$ and the family of pairs (A_n, Ω_n) and (A_n, Ω_n) are uniformly stabilizable and uniformly detectable, respectively. Then the solution Π_n of the finite dimensional approximation algebraic Riccati equation converges strongly to Π , the unique solution of the game theoretic algebraic Riccati equation

$$\lim_{n \rightarrow \infty} \|\Pi x - \Pi_n P_n x\| \rightarrow 0$$

Numerical Examples

As a numerical example, this section applies the theory presented in the paper to the control of a beam with piezoceramic actuators and subject to model uncertainty. In practice, the model uncertainty may be due to imprecise actuator characterization, actuator loss of authority due to material degradation or damage. Figure (3) and (4) depict a redundantly controlled beam with piezoceramic actuators. In the absence of model uncertainty, the governing equations characterizing the dynamic response due to piezoelectric actuation can be written

$$\begin{aligned} \rho h \frac{\partial^2 y}{\partial t^2} + EI \frac{\partial^4 y}{\partial x^4} + c_1 \frac{\partial y}{\partial t} + k_1 y \\ = \sum_i^N g_i \frac{\partial^2}{\partial x^2} (H_i(x)) u_i(t) \end{aligned} \quad (5.1)$$

where

$$H_i(x) = H(x - \alpha_i) - H(x - \beta_i) \quad (5.2)$$

and where ρ is the material density, h is the laminae thickness, EI is the bending modulus, c_1 is the viscous damping coefficient, k_1 is the stiffness constant of the beam foundation, and g_i is the piezoelectric gain. Each g_i depends upon the specific laminate geometry. The interested reader should see ²³ or ²⁵ for details. To account for several regions of degradation or damage, structured uncertainty is represented in the system as

$$\begin{aligned} \rho h \frac{\partial^2 y}{\partial t^2} + EI \frac{\partial^4 y}{\partial x^4} + c_1 \frac{\partial y}{\partial t} + k_1 y \\ = \sum_i^N \left(g_i \frac{\partial^2}{\partial x^2} (H_i(x)) + \epsilon_i \Delta_i(x) \right) u_i(t) \end{aligned} \quad (5.3)$$

or, alternatively, as injected disturbances

$$\begin{aligned} & \rho h \frac{\partial^2 y}{\partial t^2} + EI \frac{\partial^4 y}{\partial x^4} + c_1 \frac{\partial y}{\partial t} + k_1 y \\ &= \sum_i^N g_i \frac{\partial^2}{\partial x^2} (H_i(x)) u_i(t) \\ &+ \sum_i^M \epsilon_i \gamma_i(x) w_i(t), \end{aligned} \quad (5.4)$$

The utility of wavelet approximation for control problems becomes evident when one represents the control influence functions $H_i(x)$ and uncertainty distributions $\gamma_i(x)$ in terms of their wavelet interpolates as defined in section (3)

$$H_i^J(x) = \sum_r h_{i,r}^J \phi_r^J(x) \quad (5.5)$$

$$\gamma_i^J(x) = \sum_r \gamma_{i,r}^J \phi_r^J(x)$$

By substituting the galerkin approximation

$$y^J(x) = \sum_r y_r^J(t) \phi_r^J(x) \quad (5.6)$$

into equation (5.1), multiplying by the test function $v = \phi_i^J(x)$, the resulting governing equations become

$$\begin{aligned} & \sum_i \int_0^1 \phi_i^J(x) \phi_i^J(x) dx \ddot{y}_i^J(t) \\ &+ EI \sum_i \int_0^1 \phi_i^J(x) \frac{\partial^4}{\partial x^4} (\phi_i^J(x)) dx y_i^J(t) \\ &+ c_1 \sum_i \int_0^1 \phi_i^J(x) \phi_i^J(x) dx \dot{y}_i^J(t) \\ &+ k_1 \sum_i \int_0^1 \phi_i^J(x) \phi_i^J(x) dx y_i^J(t) \\ &= \sum_i g_i \sum_r h_{i,r}^J \int_0^1 \phi_i^J(x) \frac{\partial^2}{\partial x^2} (\phi_r^J(x)) dx u_i(t) \\ &+ \sum_i \epsilon_i \sum_r \gamma_{i,r}^J \int_0^1 \phi_i^J(x) \phi_r^J(x) dx w_i(t) \end{aligned} \quad (5.7)$$

By using the definition of the connection coefficients and the wavelet differentiation techniques presented in section (3), these equations reduce to

$$\begin{aligned} & \sum_i (\delta_{l,i} \ddot{y}_i^J(t) + c_1 \delta_{l,i} \dot{y}_i^J(t)) \\ &+ \sum_i (k_1 \delta_{l,i} + 2^{4J} EI \Lambda_{i,l}^{2,2}) y_i^J(t) \end{aligned} \quad (5.8)$$

$$\begin{aligned} &= 2^{2J} \sum_i \sum_r \Lambda_{i,r}^{0,2} g_i h_{i,r}^J u_i(t) \\ &+ \sum_i \sum_r \epsilon_i \gamma_{i,r}^J \delta_{l,r} w_i(t) \end{aligned}$$

Results

This paper has presented an innovative formulation using a multiresolution wavelet analysis of distributed control problems associated with soft constrained differential games on Hilbert space. As opposed to approximate optimal controls derived using linear control theory, the game theoretic approximations inherently provide for structured uncertainty. Numerical verification of the theory has demonstrated that the formulation is well-suited for modeling piezoceramic actuation, and suggests avenues of research for the control synthesis accounting for the loss of actuation. Future research will focus on the conditioning and multigrid solution of the multiresolution analysis, as well as formulations of fluid-structure interaction problems with robust control.

References

1. Daubechies, I., "Orthonormal Bases of Compactly Supported Wavelets," *Communications on Pure and Applied Mathematics*, Vol. XLI, 1988, pp. 909-996.
2. Mallat, S. G., "A Theory for Multi Resolution Signal Decomposition : The Wavelet Representation," *IEEE Transactions on Pattern Analysis and Machine Intelligence*, Vol. 11, No. 7, July 1989, pp. 674-693.
3. Chui, C. K., *Wavelets : A Tutorial in Theory and Applications*, Academic Press, 1992.
4. Glowinski, R., W. M. Lawton, M. Ravachol, and E. Tenenbaum, "Wavelet Solution of Linear and Nonlinear Elliptic, Parabolic and Hyperbolic Problems in One Space Dimension," Technical Report AD890527.1, Aware Inc., 1989.
5. Alpert, B. K., "Wavelets and Other Bases for Fast Numerical Linear Algebra," *Wavelets : A Tutorial in Theory and Applications*, Editor: Chui, Academic Press, 1992, pp. 181-216.
6. Wells, R. O., Jr., and X. Zhou, "Wavelet Interpolation and Approximate Solutions of Elliptic Partial Differential Equations," Technical Report 92-03, Rice University, Computational Mathematics Laboratory.
7. Wells, R. O., Jr., and X. Zhou, "Wavelet Solutions for the Dirichlet Problem," Technical Report 92-02,

Rice University, Computational Mathematics Laboratory.

8. Beylkin, G., "On the Representation of Operators in Bases of Compactly Supported Wavelets"
9. Beylkin, G., R. Coifman, and V. Rokhlin, "Fast Wavelet Transforms and Numerical Algorithms I," *Communications on Pure and Applied Mathematics*, Vol. XLIV, 1991, pp. 141-183.
10. Resnikoff, H. L., "Wavelets and Adaptive Signal Processing," Technical Report AD910805, Aware Inc., 1991.
11. Latto, A., H. L. Resnikoff, and E. Tenenbaum, "The Evaluation of Connection Coefficients of Compactly Supported Wavelets," Technical Report AD910708, Aware Inc., 1991.
12. Jaffard, S., and Ph. Laurencot, "Orthonormal Wavelets, Analysis of Operators, and Applications to Numerical Analysis," *Wavelets: A Tutorial in Theory and Applications*, Editor: Chui, Academic Press, 1992, pp. 543-601.
13. Brislawn, C., and I. G. Rosen, "Wavelet Based Approximation in the Control of Distributed Parameter Systems," *Numerical Functional Analysis and Optimization*, Vol. 12, 1991, pp. 33-77.
14. Ito, K., Strong convergence and convergence rates of approximating solutions for algebraic Riccati equations in Hilbert spaces, in *Distributed Parameter Systems*, Springer Lec. Notes in Control and Inf. Sci., 102, 1987, 153-166.
15. Kappel, F. and D. Salamon, An approximation theorem for the algebraic Riccati equation, *SIAM J. Control and Optimization*, 28, 1990, 1136-1147.
16. Peterson, I.R., Some new results on algebraic Riccati equations arising in linear quadratic differential games and the stabilization of uncertain systems, *Systems and Control Letters*, 10, 1988, 341-348.
17. R. Fabiano, A. J. Kurdila, and C. Kim, "Numerical Methods for Robust Control Design for Distributed Parameter Systems," Proceedings of the 31st Conference on Decision and Control, Tucson, Arizona, December 1992.
18. Andrew J. Kurdila, R. H. Fabiano, and Thomas Strganac, "Robust Control of Distributed Parameter Systems with Structured Uncertainty," proceedings of the Conference on Computation and Control III.
19. A. J. Kurdila, R. Fabiano, C. Kim, and S. Hsu, "Convergence of Robust Control Design For Distributed Parameter Systems," AAS/AIAA space-flight Mechanics Meeting, AAS92-155, Colorado, Feb.24-26, 1992.
20. A. J. Kurdila, R. Fabiano, T. Strganac, and S. Hsu, "Semigroup Approximation and Robust Stabilization of Distributed Parameter Systems," presented at the NASA Workshop on Distributed Parameter Modeling and Control of Flexible Aerospace Systems, Jun8-9,1992.
21. Pritchard, A.J. and S. Townley, Robustness optimization for abstract, uncertain control systems: unbounded inputs and perturbations, Proc. IFAC Symposium on DPS, Perpignan, June, 1989, Eds. El Jai and Amaroux, 117-121.
22. Rhee, I. and J. Speyer, A game theoretic controller for a linear time-invariant system with parameter uncertainty and its application to the space station, AIAA paper number AIAA-90-3220-CP, 1990.
23. C. K. Lee, and F. C. Moon, "Model Sensors/Actuator," Transaction of the ASME, Vol. 57, June 1990.
24. Tamer, Basar, and Pierre, Bernhard, " H^∞ -Optimal Control and Related Minmax Design Problem," Birkhauser, Boston, 1991.
25. H. T. Banks, W. Fang, R. J. Silcox, and R.C. Smith, "Approximation Methods for Control of Acoustic/Structure Models with Piezoceramic Actuators," ICSA Report No. 91-88., Dec. 1991.

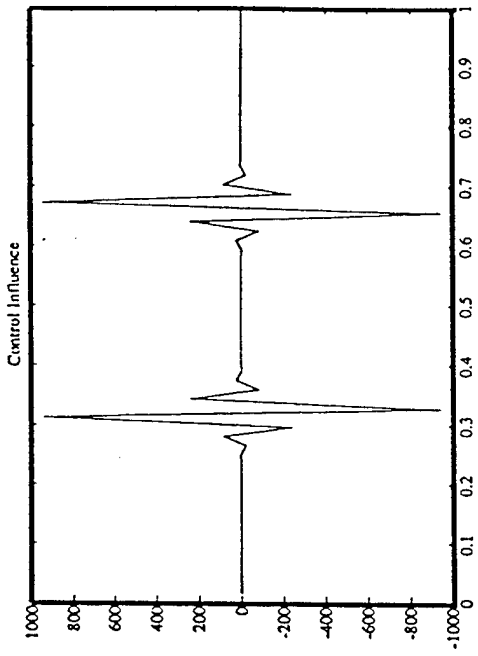

Figure (3) Control Influence Function

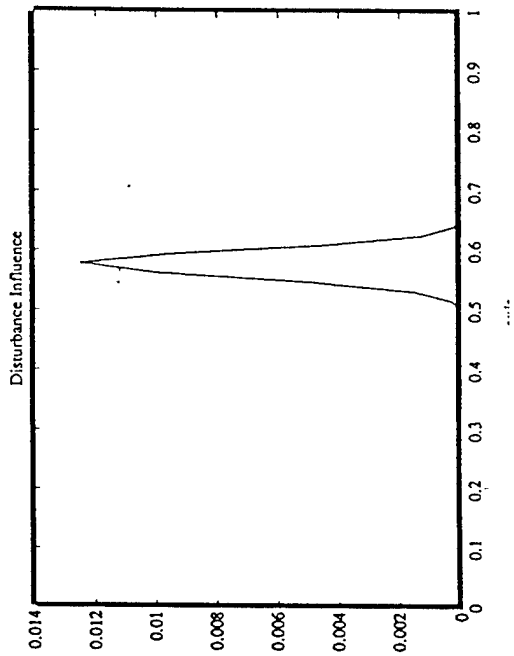

Figure (4) Control Actuation Uncertainty Function

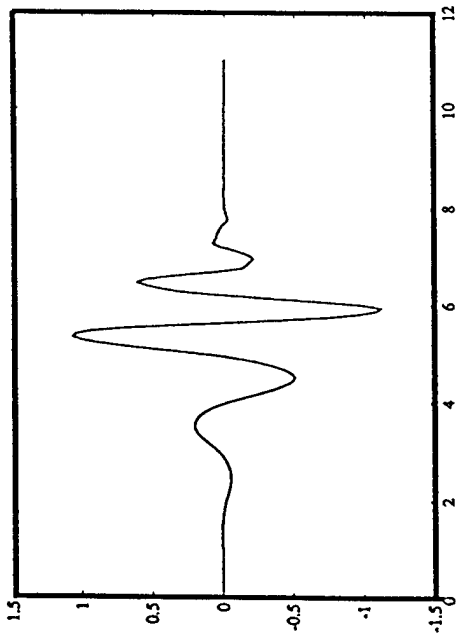

Figure (1) Daubechies Wavelet Function, M=6

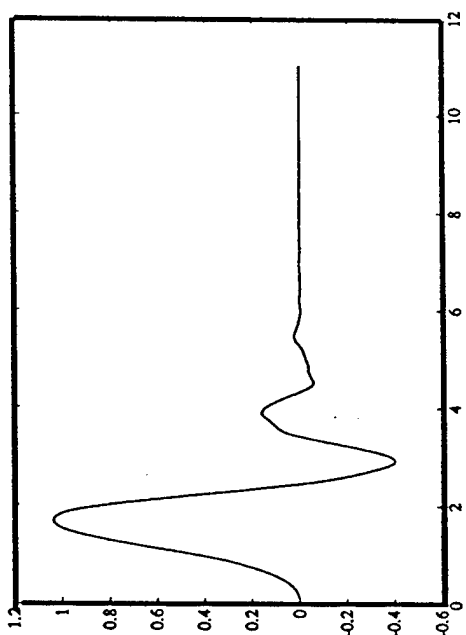

Figure (2) Daubechies Scaling Function, M=6

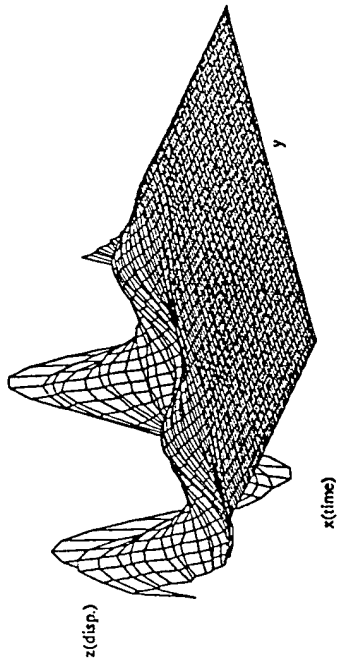

Figure (5) Transient Response, $J=5$, LQR

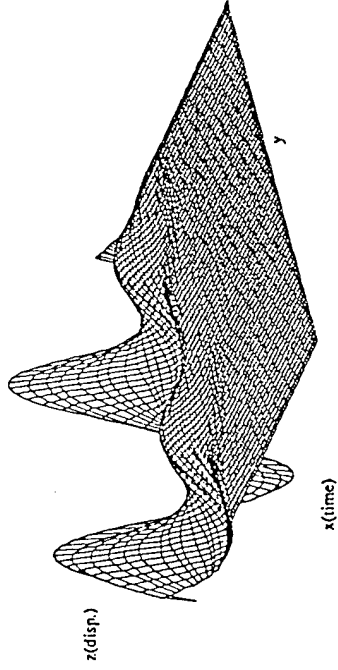

Figure (7) Transient Response, $J=6$, LQR

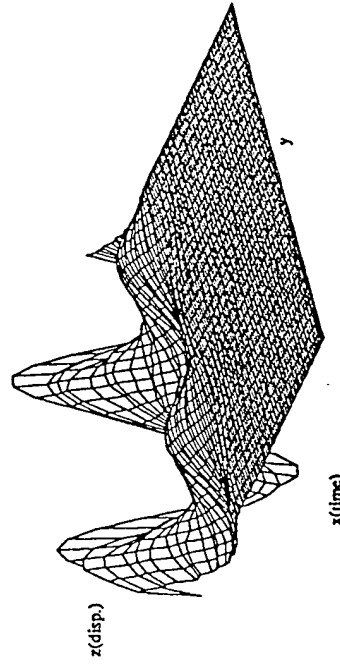

Figure (6) Transient Response, $J=5$,
Game Theoretic Control

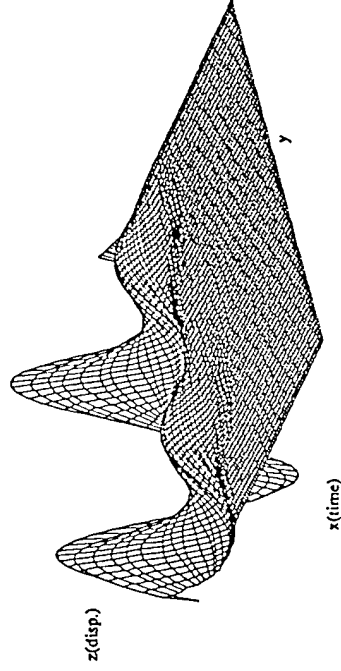

Figure (8) Transient Response, $J=6$,
Game Theoretic Control

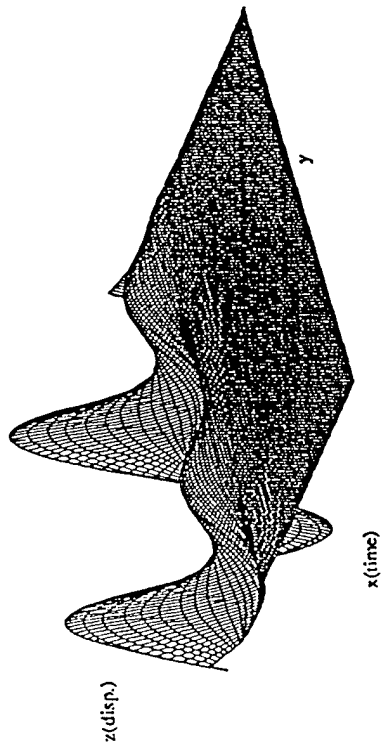

Figure (9) Transient Response, $J=6$, LQR

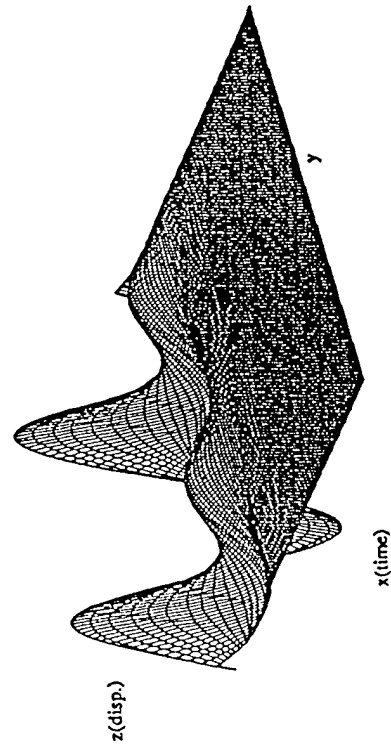

Figure (10) Transient Response, $J=6$,
Game Theoretic Control

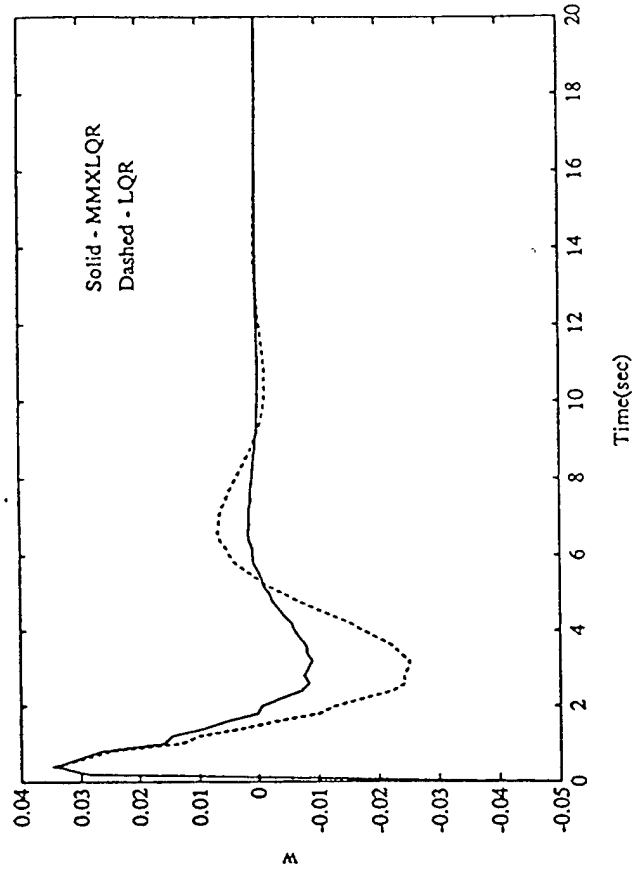

Figure (11) Center Node Transient Response
Comparison, LQR vs Game Theoretic, $J=7$

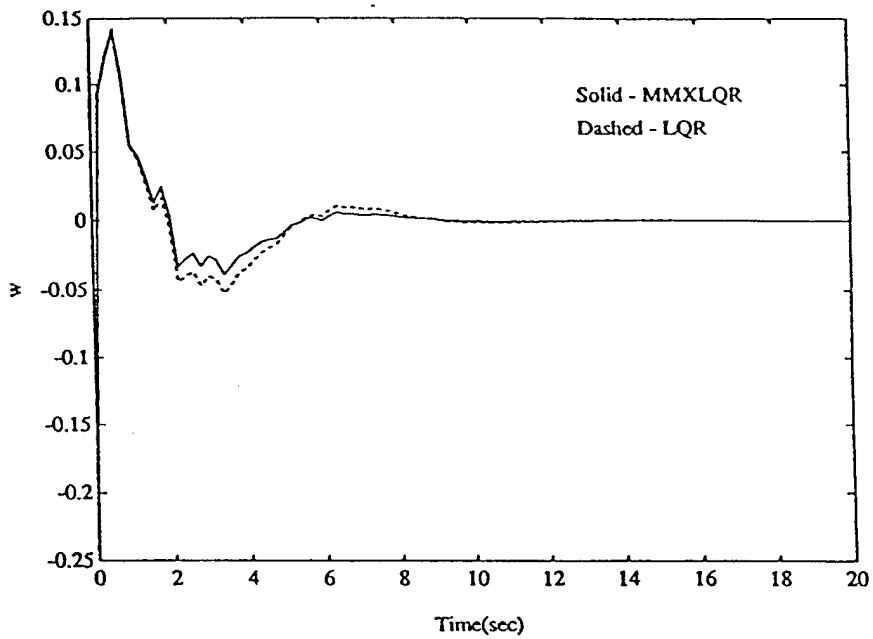

Figure (12) Center Node Transient Response Comparison, LQR vs Game Theoretic, $J=5$

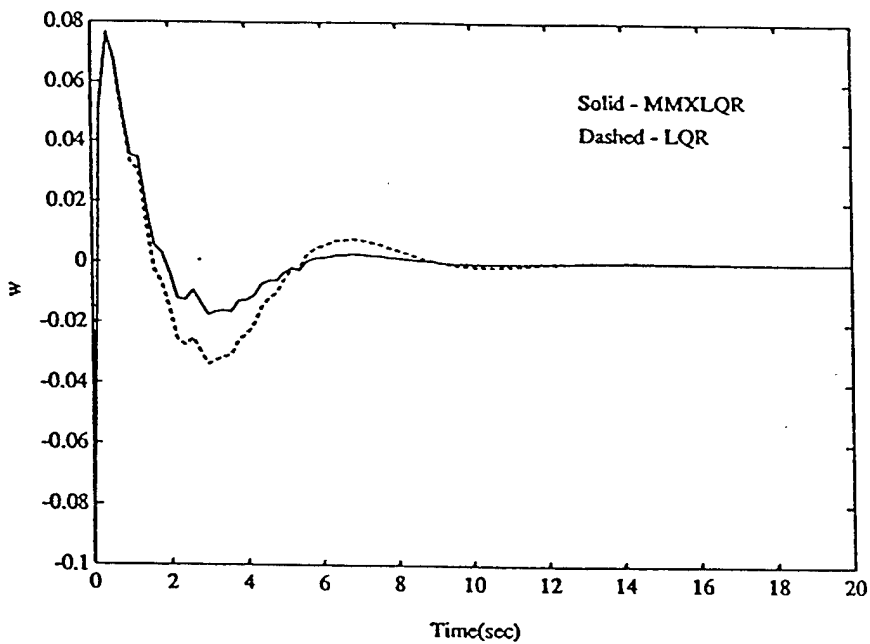

Figure (13) Center Node Transient Response Comparison, LQR vs Game Theoretic, $J=6$

Attachment (4)

(4) *Dynamic Response and Game Theoretic Control of Evolving Structural Systems*, T. Strganac, A. Kurdila, C. Kim and Y. Kim, AIAA-94-1720.

**Dynamic Response and Game Theoretic Control
of Evolving Structural Systems**

**Thomas W. Strganac, Andrew J. Kurdila,
Cheolho Kim, and Young Ik Kim**

**Center for Mechanics and Control
Department of Aerospace Engineering
Texas A & M University
College Station, Texas 77843-3141**

AIAA 94-1720

**35th AIAA / ASME / ASCE / AHS / ASC
Structures, Structural Dynamics and Materials Conference
&
AIAA Dynamics Specialists Conference
&
AIAA Adaptive Structures Forum**

**Hilton Head, South Carolina
April 1994**

DYNAMIC RESPONSE AND GAME THEORETIC CONTROL OF EVOLVING STRUCTURAL SYSTEMS

Thomas W. Strganac*, Andrew J. Kurdila*, Cheolho Kim**, and Young Ik Kim**

Center for Mechanics and Control
Department of Aerospace Engineering
Texas A&M University
College Station, Texas 77843-3141

ABSTRACT

The authors present a study of the dynamic response and control of coupled fluid-structure systems in which the primary structure or distributed control system evolves. These systems include control sensing and control actuation elements embedded in the structure. Structural systems considered are those in which damage occurs on a slow time scale, or damage that occurs due to microcracking and delamination. Aeroelastic response is shown to be dependent upon the distribution and accumulation of damage, which itself is dependent upon the presence of the aerodynamic loads. Dynamic characteristics are unique to the coupled damage / aeroelastic system and are developed as part of the solution methodology. The authors establish the importance of the intrinsic interdependence of stability and damage, and establish the importance of deriving a control theory for uncertainties in the evolving system. Findings indicate significant changes occur in the dynamic response characteristics due to damage. These results further suggest some control strategies can encounter difficulties with these evolving systems.

INTRODUCTION

Currently, the research community is vigorously exploring the concept of actively suppressing dynamic instabilities by using "smart" materials. Furthermore, the engineering community has developed new materials - such as composite materials, piezoelectric materials, and shape memory alloys - to tailor the structural response. The primary objectives of the research described in the paper include the development and verification of a control model for the coupled fluid-structure-control system with structural/control evolution. Much of the related research does not consider the existence

*Associate Professor, Senior Member AIAA.

**Graduate Research Assistant, Member AIAA.

of damage or change in the constitutive behavior. Control methodologies are required which address the partial loss of distributed actuation systems, distributed damage of the structure, or evolution of the material constitutive laws. Control theories are required which are fault tolerant with respect to loss of either sensing or actuation capabilities over portions of the structure. The investigators examine the effect of damage accumulation in aeroelastic structures and elucidate the unique behavior of the dynamics for the evolutionary structure. The primary goal of the research includes the development of the fluid-structure control model with structural evolution. The model permits the examination of dynamic response and aeroelastic stability characteristics of the evolving system, as well as damage detection and system identification.

Aeroelasticity is the phenomenon resulting from the interaction between aerodynamic, inertial, and structural forces. A distinguishing characteristic of aeroelasticity is the presence of time dependent and displacement dependent aerodynamic loads. Traditionally, the elastic forces of the structure are assumed linear and the stiffness of the structure is assumed to remain constant for the life of the structure. However, these assumptions are not valid for structures which incorporate composite or active materials. A method is developed to treat the interaction of aerodynamic forces, dynamics of the structure, damage accumulation, and control. The method is developed for the case of panel flutter which is a self-excited oscillatory instability caused when panels are exposed to high-speed airflow on one side of the structure¹. Few researchers have examined the effects of evolution on aeroelastic phenomena. Kim et.al² and Strganac et.al³ present the development of an aeroelastic model in which damage is inherent.

Dowell briefly described the change in the aeroelastic stability arising from the degradation of the isotropic panel structure⁴. Dowell suggested that nonlinear flutter analysis would permit the prediction of the fatigue life of the associated panel structure. Dowell further suggested that conventional fatigue data could be used for estimating the fatigue life of the panel structure specifically at flutter conditions. Xue, et.al studied the fatigue life of beams with thermal effects⁵. Frequencies and stresses for the limit-cycle behavior of these

The damage-dependent stiffness components ($[A']$, $[B']$, and $[D']$) are described in terms of the damage-dependent, angle-ply stiffness, $[\bar{Q}']^0$. Talerja defines a parameter, ξ , to describe damage within $[\bar{Q}']$. The stiffness of the composite laminate with damage is found as

$$(A'_{ij}, B'_{ij}, C'_{ij}) = \int \bar{Q}'_{ij}(1, z, z^2) dz \quad (3.2)$$

where

$$\bar{Q}'_{ij} = \bar{Q}'_{ij}[E_1(\xi), E_2(\xi), \nu_{12}(\xi), G_{12}(\xi)]$$

The properties for the principal directions of a lamina are given by

$$\begin{aligned} E_1 &= E_1^0 + 2\xi(C_3 + C_8(\nu_{12}^0)^2 - C_{16}\nu_{12}^0) \\ E_2 &= E_2^0 + 2\xi(C_8 + C_3(\nu_{21}^0)^2 - C_{16}\nu_{21}^0) \\ \nu_{12} &= \nu_{12}^0 + \xi\left(\frac{1 - \nu_{12}^0\nu_{21}^0}{E_2^0}\right)(C_{16} + 2C_8\nu_{12}^0) \\ G_{12} &= G_{12}^0 - 2\xi C_{13} \end{aligned} \quad (3.3)$$

where E_1^0, E_2^0, ν_{12}^0 , and G_{12}^0 are properties of the undamaged lamina. C_3, C_8, C_{13} , and C_{16} are phenomenological constants. The damage parameter, ξ , represents the crack density, the magnitude of which is subject to a damage growth law. The damage growth law for matrix cracking is given as¹⁰

$$d\alpha_{22} = \frac{d\alpha_{22}}{dS} k G^n dN \quad (3.4)$$

where α_{22} is the ISV representing matrix cracking, k and n are material constants, G is the strain energy release rate, S is the crack surface, and N is the number of cycles. The ISV is converted to the damage parameter, ξ .

Game Theoretic Control

The presence of damage to the primary structure, or the partial loss of distributed actuator systems, presents unique difficulties in feedback control. Hence, a game-theoretic control methodology is derived in this paper for distributed parameter systems subject to model uncertainties arising from classes of damage. In some recent work, conventional linear quadratic regulator (LQR) and linear quadratic Gaussian (LQG) control strategies have been employed to enhance vibration suppression in aeroelastic problems¹¹. However, it is well known that LQG control designs can exhibit arbitrarily poor response for unmodelled perturbations, and adaptive materials can exhibit different response characteristics over time due to evolution of their constitutive laws. Hence, innovative strategies for the realization of controllers associated with game-theoretic

control, appropriate for direct treatment of the governing partial differential equations, are derived. Game-theoretic control accounts for a class of disturbances subject to well-defined classes of initial conditions. Our results show a significant improvement compared to traditional LQR/LQG methods. Although some efforts have been made to derive active control strategies for aeroelastic structures using smart materials, this research is in the early stage of development. The authors are aware of no research that treats the fundamental issue of robustness of control design with respect to actuator degradation expected during routine operation, let alone the possibility of sensor or actuator failure. While numerous research papers on the use of smart materials for active control are available, the works of Scott and Rogers are particularly pertinent^{11,12}. In Scott, an LQR strategy is employed to design piezoelectric controls to reduce panel flutter and raise the value of dynamic pressure associated with flutter. The analytical results are extremely promising. On the other hand, the work of Rogers uses shape memory alloys to reduce crack growth in composites. One potential drawback with the approach taken by Scott is that the LQR design strategy does not account a priori for injected disturbances or material change which will develop in fatigue or damage. Likewise, Rogers clearly demonstrates that shape memory alloys have the potential to significantly reduce local stress concentrations; however, an active control strategy based upon some optimality principle does not exist. Furthermore, the approach in Rogers deals with degradation of the composite laminate while the integrity of the control is unaffected.

To motivate the design of control strategies for the aeroelastic model with damage accumulation, the governing equations can be interpreted as a two player game. The simplest explanation is achieved by examining the prior governing equations, but including control. In this case, the two right hand side terms have "adversarial" roles,

$$[M]\{\ddot{w}\} + [C]\{\dot{w}\} + [K]\{w\} = [[K_D] + [A]]\{w\} + [B]\{u\} \quad (4.1)$$

The stiffness damage and aeroelastic terms, $[[K_D] + [A]]$, tend to destabilize the system, while the control terms, $[B]$, are selected to offset this effect. The destabilizing terms represent localized damage from microcracking or delamination, actuation loss, and other unmodelled disturbances. The control design philosophy employed in this paper can be formulated by first considering the abstract Cauchy problem on a Hilbert space H

$$\begin{aligned} \dot{x}(t) &= Ax(t) + Bu(t) \\ x(0) &= x_0 \\ y(x) &= Cx(t) \end{aligned} \quad (4.2)$$

where $B \in L(U, H)$ (i.e., the linear operator from U into H), U is a Hilbert space, and A is the infinitesimal

following modification¹⁴ of a result due to Zabczyk^{20,21} is required.

Lemma 4.1 Suppose that $K \in L(H)$ and (C, A) is detectable. If there is an operator $\Pi \geq 0$ satisfying the Liapunov equation

$$\langle \Pi x, Ay \rangle + \langle Ax, \Pi y \rangle = -\langle Cx, Cy \rangle - \langle Kx, Ky \rangle \quad (4.13)$$

$\forall x, y \in \text{dom} A$ then A is stable. Now, the following result can be derived, in a manner similar to the approach in Rhee¹³ and Fabiano¹⁴.

Theorem 4.2 Suppose that (C, A) is detectable. If Π is a nonnegative definite solution of (4.13), then the feedback control $u(t) = -\hat{R}^{-1} B^* \Pi x(t)$ stabilizes (4.5) for all $\|L_A\| < \gamma$, $\|L_B\| < \gamma$.

Proof: In Hilbert space, it must be shown that the closed loop operator $A_c = A + \Delta A - (B + \Delta B) \hat{R}^{-1} B^* \Pi$ is stable. Note that (4.12) can be written as

$$\langle \Pi x, A\hat{y} \rangle + \langle Ax, \Pi\hat{y} \rangle + \langle Qx, \hat{y} \rangle - \langle (B\hat{R}^{-1}B^* - \gamma^2[\hat{D}\hat{D}^* + \hat{F}\hat{F}^*])\Pi x, \Pi\hat{y} \rangle = 0 \quad (4.14)$$

for all $x, \hat{y} \in \text{dom} A$. It follows that

$$\begin{aligned} \langle \Pi x, A_c\hat{y} \rangle + \langle A_c x, \Pi\hat{y} \rangle &= \langle \Pi x, A\hat{y} \rangle + \langle \Pi x, \Delta A\hat{y} \rangle \\ &- \langle \Pi x, (B + \Delta B)\hat{R}^{-1}B^*\Pi\hat{y} \rangle \\ &+ \langle Ax, \Pi\hat{y} \rangle + \langle \Delta Ax, \Pi\hat{y} \rangle + \langle Qx, \hat{y} \rangle \\ &- \langle (B\hat{R}^{-1}B^* - \gamma^2[\hat{D}\hat{D}^* + \hat{F}\hat{F}^*])\Pi x, \Pi\hat{y} \rangle \\ &- \gamma^2 \langle (\hat{D}\hat{D}^* + \hat{F}\hat{F}^*)\Pi x, \Pi\hat{y} \rangle - \langle Qx, \hat{y} \rangle \\ &- \langle \Delta B\hat{R}^{-1}B^*\Pi x, \Pi\hat{y} \rangle \end{aligned}$$

The underlined terms cancel to zero, so that

$$\begin{aligned} \langle \Pi x, A_c\hat{y} \rangle + \langle A_c x, \Pi\hat{y} \rangle &= \\ &- \langle Cx, C\hat{y} \rangle - \gamma^2 \langle D^*\Pi x, D^*\Pi\hat{y} \rangle - \gamma^2 \langle \hat{F}^*\Pi x, \hat{F}^*\Pi\hat{y} \rangle \\ &- \langle B^*\Pi x, \hat{R}^{-1}B^*\Pi\hat{y} \rangle + \langle \Pi x, \hat{D}\hat{L}_A\hat{E}\hat{y} \rangle - \langle \hat{E}x, \hat{E}\hat{y} \rangle \\ &+ \langle \hat{D}\hat{L}_A\hat{E}x, \Pi\hat{y} \rangle - \langle \Pi x, \hat{F}\hat{L}_B\hat{G}\hat{R}^{-1}B^*\Pi\hat{y} \rangle \\ &- \langle \hat{F}\hat{L}_B\hat{G}\hat{R}^{-1}B^*\Pi x, \Pi\hat{y} \rangle \end{aligned}$$

Continuing, we have

$$\begin{aligned} \langle \Pi x, A_c\hat{y} \rangle + \langle A_c x, \Pi\hat{y} \rangle &= -\langle Cx, C\hat{y} \rangle \\ &- \gamma^2 \langle (\hat{D}^*\Pi - \frac{1}{\gamma^2}\hat{L}_A\hat{E})x, (\hat{D}^*\Pi - \frac{1}{\gamma^2}\hat{L}_A\hat{E})\hat{y} \rangle \\ &- \frac{1}{\gamma^2} \langle (\gamma^2\hat{F}^* + \hat{L}_B\hat{G}\hat{R}^{-1}B^*)\Pi x, \\ &\quad (\gamma^2\hat{F}^* + \hat{L}_B\hat{G}\hat{R}^{-1}B^*)\Pi\hat{y} \rangle \\ &- \langle R\hat{R}^{-1}B^*\Pi x, \hat{R}^{-1}B^*\Pi\hat{y} \rangle - \langle \hat{E}x, (I - \frac{1}{\gamma^2}\hat{L}_A^*\hat{L}_A)\hat{E}\hat{y} \rangle \\ &- \langle \hat{G}\hat{R}^{-1}B^*\Pi x, (I - \frac{1}{\gamma^2}\hat{L}_B^*\hat{L}_B)\hat{G}\hat{R}^{-1}B^*\Pi\hat{y} \rangle \end{aligned}$$

Now if $\|L_A\| < \gamma$ and $\|L_B\| < \gamma$, where $\|\cdot\|$ is the operator norm, then the right hand side can be written

as $-\langle Cx, Cy \rangle - \langle Kx, Ky \rangle$, so that the result follows from Lemma 3.1. One should carefully note that the above proof relies on the fact that $DD^*: H \rightarrow H$, for example, $D^*: H \rightarrow H^N$. The proof in Rhee¹³ and Fabiano¹⁴ is structured such that $D^*: H \rightarrow H$.

Control Formulation

As an illustration, we examine a beam (Fig.1) problem with piezoelectric actuation. In practice, the model uncertainty may be due to imprecise actuator characterization, actuator loss of authority due to material degradation, mis-calibration, microcracking or delamination. In the absence of model uncertainty, the governing equations characterizing the dynamic response due to piezoelectric actuation can be idealized as

$$\begin{aligned} \rho h \frac{\partial^2 y}{\partial t^2} + EI(x) \frac{\partial^4 y}{\partial x^4} + c_1 \frac{\partial y}{\partial t} + k_1 y \\ = g \frac{\partial^2}{\partial x^2} [H(x)] u(t) \end{aligned} \quad (5.1)$$

where

$$H(x) = H(x - \alpha) - H(x - \beta) \quad (5.2)$$

is the Heaviside function and ρ is the material density, h is the laminae thickness, $EI(x)$ is the bending modulus, c_1 is the viscous damping coefficient, k_1 is the stiffness constant of the beam foundation, and g is the piezoelectric gain. To account for several regions of degradation or damage, structured uncertainty is represented in the system as

$$\begin{aligned} \rho h \frac{\partial^2 y}{\partial t^2} + \frac{\partial^2}{\partial x^2} [(EI(x) + \epsilon_{EI} \Delta_{EI}) \frac{\partial^2 y}{\partial x^2}] + c_1 \frac{\partial y}{\partial t} + k_1 y \\ = g \frac{\partial^2}{\partial x^2} ([H(x)] + \epsilon_b \Delta_b(x)) u(t) \end{aligned} \quad (5.3)$$

The boundary conditions are given by

$$\begin{aligned} y(t, 0) = y_x(t, 0) = 0 \\ [(EI(x) + \epsilon_{EI} \Delta_{EI}(x)) Y_{xx}(t, x)]_{x=1} = 0 \\ \frac{\partial}{\partial x} [(EI(x) + \epsilon_{EI} \Delta_{EI}(x)) Y_{xx}(t, x)]_{x=1} = 0 \end{aligned}$$

and initial conditions are

$$y(0, x) = y_0(x), \quad y_t(0, x) = y_1(x)$$

In this equation $y(t, x)$ represents the transverse displacement of the beam at time t and position x along the beam of length L . This system can be formulated

bounds with respect to the different uncertainty. In figure 14, the distribution of $EI(x)$ from the microcrack density data derived in this paper is used in conjunction with the game theoretic control law. Figure 15 shows the control influence matrix $b(x)$. In this case, the maximum allowable perturbation has been selected as the maximum from the microcrack density over a portion of the plate. From these performance results, we can see the game theoretic control with the multi-player game theory is more robust than the LQR control law.

CONCLUDING REMARKS

The use of composites and active materials requires the characterization of naturally-occurring, unavoidable damage effects. Dynamic and aeroelastic response is dependent upon damage. In turn, the growth and distribution of damage is not uniform; rather, damage growth is dependent upon the presence of the aerodynamic loads. Modal and stability characteristics provide a noninvasive measure for damage detection and system identification. Active control of aeroelastic structures must account for failure of the primary structure, sensors, and actuators.

ACKNOWLEDGEMENT

This research has been partially supported by AFOSR grant F49620-92-J-0450, the authors wish to thank the AFOSR for their support.

REFERENCES

- 1 Dowell, E.H., "Aeroelasticity of plates and shells", Noordhoff International Publishing, Leyden, Netherlands, 1975.
- 2 Kim, Y.I. and Strganac, T.W., Aeroelastic Stability of Damaged Composite Structures, *AIAA 33rd Structures, Structural Dynamics and Materials Conference*, *AIAA Paper 92-2392*, April 1992.
- 3 Strganac, T., Kim, Y.I., and Kurdila, A.J., "Nonlinear Flutter of Composite Plates with Damage Evolution", *AIAA 34th Structures, Structural Dynamics, and Materials Conference*, *AIAA Paper No. 93-1546*, April 1993.
- 4 Dowell, E.H., "Fatigue Life Estimation of Fluttering Panels", *AIAA Journal* Vol.8, No.10, 1970.
- 5 Xue, David Y. and Mei, Chuh, "Finite Element Nonlinear Flutter and Fatigue Life of 2-D Panels with Temperature Effects", *AIAA 32nd Structures, Structural Dynamics, and Materials Conference*, 1991.
- 6 Chen, Wen-Hwa and Lin, Heng-Chih, "Flutter Analysis of Thin Cracked Panels Using the Finite Element Method", *AIAA Journal* Vol.23, No.5, 1985.
- 7 Ashley, H. and Zartarian, G., "Piston Theory - A New Aerodynamic Tool for The Aeroelastician", *Journal of The Aeronautical Sciences*, Vol. 23, No.12, pp 1109-1118, 1956.
- 8 Coleman, B.D. and Gurtin, M.E., "Thermodynamics with Internal State Variables", *Journal of Chemical Physics*, Vol.47, 1967.
- 9 Sanders, D.R., Kim, Y.I., and Stubbs, N., "Nondestructive Evaluation of Damage in Composite Structures using Modal Parameters", *Experimental Mechanics*, September, 1992.
- 10 Lo, D.C., Allen, D.H., and Harris, C.E., "A Continuum Model for Damage Evolution in Laminated Composites", *Inelastic Deformations of Composite Materials*, G.J. Dvorak, Ed. Springer-Verlag, 1990.
- 11 Scott, R.C. and Weisshaar, T.A., Controlling Panel Flutter Using Adaptive Materials.
- 12 Rogers, C.A., Liang, C., and Li, S., Active Damage Control of Hybrid Materials Systems Using Induced Strain Actuator, *AIAA 32nd Structures, Structural Dynamics and Materials Conference*, Vol. 2, pp 1190-1203, April 1991.
- 13 Rhee, I. and J. Speyer, A game theoretic controller for a linear time-invariant system with parameter uncertainty and its application to the space station, *AIAA paper number AIAA-90-3220-CP*, 1990.
- 14 R. Fabiano, A. J. Kurdila, and C. Kim, "Numerical Methods for Robust Control Design for Distributed Parameter Systems," *Proceedings of the 31st Conference on Decision and Control*, Tucson, Arizona. December 1992.
- 15 Fabiano, R.H., Kurdila, A.J., and Strganac, T.W., Robust Control of Distributed Parameter Systems with Structural Uncertainty, *Proceedings of the Conference on Computation and Control III*, Progress in Systems and Control Theory, K. Bowers and J. Lund, Ed., 1992.
- 16 Bensoussan, A., Saddle points of convex concave functionals, in *Differential Games and Related Topics*, H.W. Kuhn and G.P. Szego, eds., North-Holland, Amsterdam, 1971, 177-200.
- 17 B.van Keulen, M. Peters and R. Curtain, " H^∞ -control with state-feedback: the infinite dimensional case", to appear in the *Journal of Mathematical System, Estimation and Control*.
- 18 Tamer, Basar, and Pierre, Bernhard, " H^∞ -Optimal Control and Related Minmax Design Problem," Birkhauser, Boston, 1991.
- 19 Gibson, J.S., Linear-quadratic optimal control of hereditary differential systems: infinite dimensional

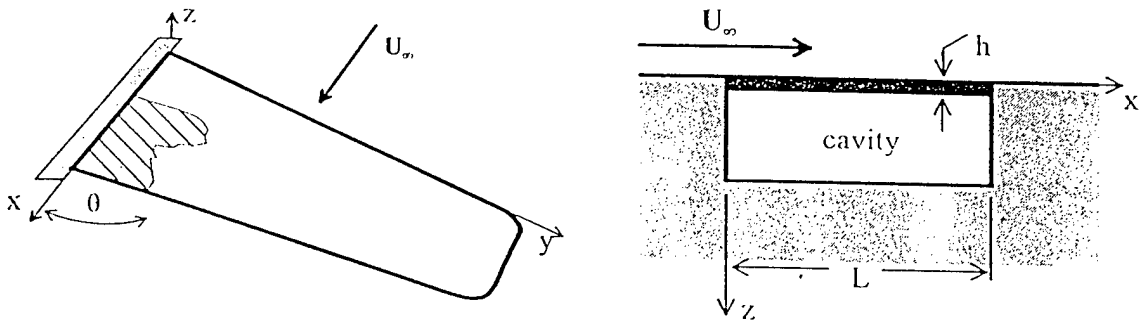

Fig. 1. Aeroelastic stability and control is predicted for a composite wing structure with distributed damage. The left view illustrates the wing structure. The right view illustrates the "beam" case of panel flutter.

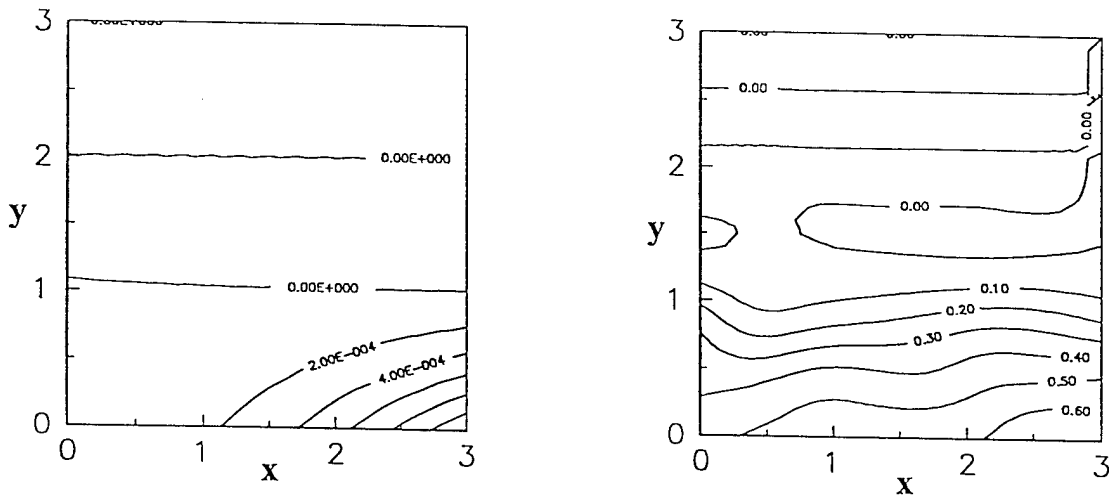

Fig. 2. Damage is not uniform and depends upon the aeroelastic response. The distribution of damage is shown for an outer ply of the wing structure (left view - early damage; right view - prior to failure).

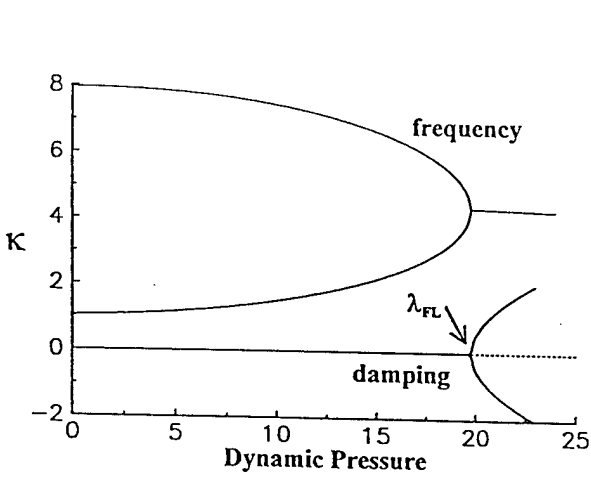

Fig. 3. The frequency and damping characteristics depend on the dynamic pressure. Flutter occurs as two (or more) modes coalesce to a common frequency and the system becomes undamped.

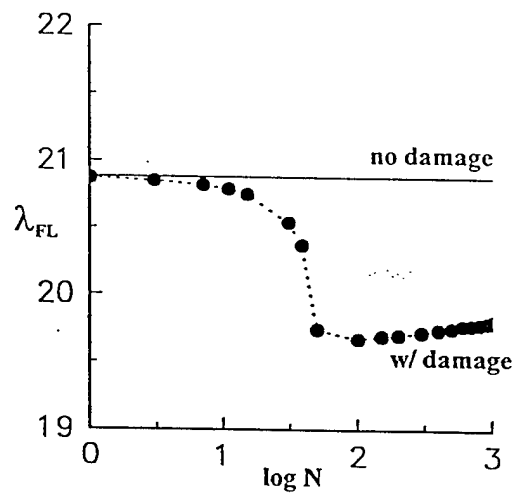

Fig. 4. Aeroelastic instabilities change with time (N) due to the growth of damage. The flutter boundary reflects the spatial and temporal distribution of stress and damage.

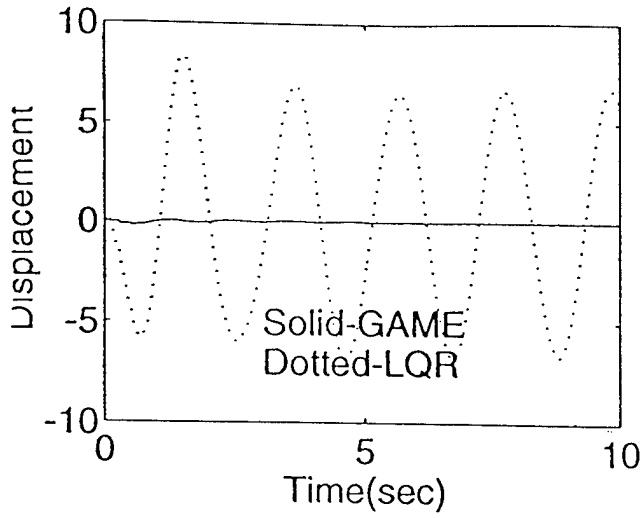

Fig. 11. Initial Response at Center

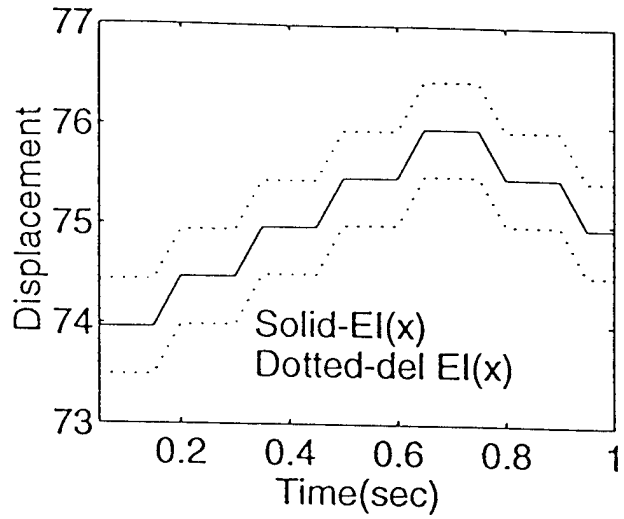

Fig. 12. Variation of EI(x) ($\gamma=0.0064$)

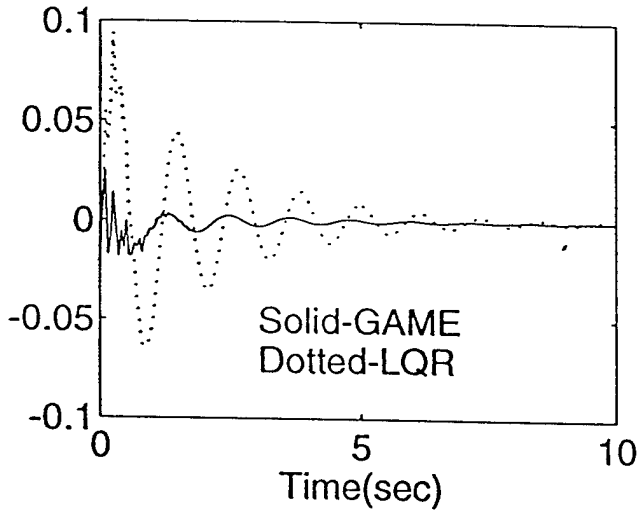

Fig. 13. Initial Response at Center

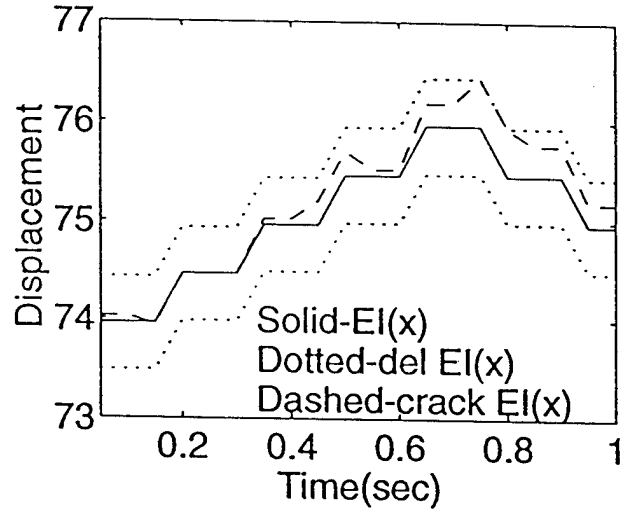

Fig. 14. Variation of EI(x) (using crack density data)

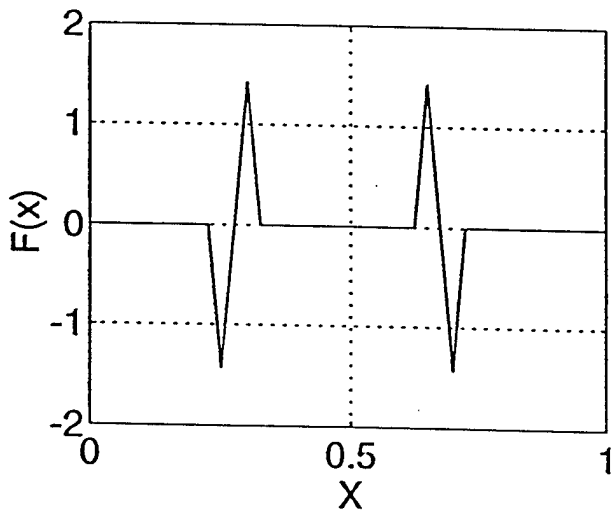

Fig. 15. Control Force