

NAVAL POSTGRADUATE SCHOOL MONTEREY, CALIFORNIA



THESIS

**POWER PLANT AND
DRIVE TRAIN IMPROVEMENTS
OF THE
NPS *HUMMINGBIRD*
REMOTELY PILOTED HELICOPTER**

by

Robert E. Conway

September, 1996

Thesis Advisor:

E. Roberts Wood

Approved for public release; distribution is unlimited.

19970121 207

DTIC QUALITY INSPECTED 1

REPORT DOCUMENTATION PAGE

Form Approved OMB No. 0704-0188

Public reporting burden for this collection of information is estimated to average 1 hour per response, including the time for reviewing instruction, searching existing data sources, gathering and maintaining the data needed, and completing and reviewing the collection of information. Send comments regarding this burden estimate or any other aspect of this collection of information, including suggestions for reducing this burden, to Washington Headquarters Services, Directorate for Information Operations and Reports, 1215 Jefferson Davis Highway, Suite 1204, Arlington, VA 22202-4302, and to the Office of Management and Budget, Paperwork Reduction Project (0704-0188) Washington DC 20503.

1. AGENCY USE ONLY (Leave blank)	2. REPORT DATE September 1996	3. REPORT TYPE AND DATES COVERED Master's Thesis	
4. TITLE AND SUBTITLE POWER PLANT AND DRIVE TRAIN IMPROVEMENTS OF THE NPS <i>HUMMINGBIRD</i> REMOTELY PILOTED HELICOPTER		5. FUNDING NUMBERS	
6. AUTHOR(S) Conway, Robert E.		8. PERFORMING ORGANIZATION REPORT NUMBER	
7. PERFORMING ORGANIZATION NAME(S) AND ADDRESS(ES) Naval Postgraduate School Monterey CA 93943-5000			
9. SPONSORING/MONITORING AGENCY NAME(S) AND ADDRESS(ES)		10. SPONSORING/MONITORING AGENCY REPORT NUMBER	
11. SUPPLEMENTARY NOTES The views expressed in this thesis are those of the author and do not reflect the official policy or position of the Department of Defense or the U.S. Government.			
12a. DISTRIBUTION/AVAILABILITY STATEMENT Approved for public release; distribution is unlimited.		12b. DISTRIBUTION CODE	
13. ABSTRACT (maximum 200 words) Originally designed as a target drone for the U.S. Army, the NPS <i>Hummingbird</i> has undergone several modifications to convert it into a reliable research platform. The 165 pound remotely piloted helicopter (RPH) is powered by a Weslake Aeromarine Engines Limited (WAEL) 342 two stroke, twin cylinder, 25 hp, gasoline engine. An engine failure due to cylinder overheating halted research efforts until investigation as to the cause and subsequent corrections could be made. Costing approximately \$3000 per engine, another failure is unacceptable. The tasks undertaken in this thesis were to investigate the cause of the overheat failure and improve the engine cooling system. Cooling system corrections required total redesigns of the engine cooling and engine start systems. Additionally, research of the RPH's history revealed a need for a torsional shock absorber to be incorporated in the drive train to increase component life. The changes made to <i>Hummingbird</i> provide a decrease in empty weight, minimal center of gravity change and, most importantly, an increase in user safety furnishing the Department of Aeronautics and Astronautics with a dependable vehicle for rotary wing research.			
14. SUBJECT TERMS: Helicopter, Radio-Controlled, Power Plant, Drive Train, Unmanned Aerial Vehicle		15. NUMBER OF PAGES 102	16. PRICE CODE
17. SECURITY CLASSIFICATION OF REPORT Unclassified	18. SECURITY CLASSIFICATION OF THIS PAGE Unclassified	19. SECURITY CLASSIFICATION OF ABSTRACT Unclassified	20. LIMITATION OF ABSTRACT UL

Approved for public release; distribution is unlimited.

**POWER PLANT AND DRIVE TRAIN IMPROVEMENTS
OF THE
NPS *HUMMINGBIRD* REMOTELY PILOTED HELICOPTER**

Robert E. Conway
Lieutenant Commander, United States Navy
B.S., United States Naval Academy, 1985

Submitted in partial fulfillment
of the requirements for the degree of

MASTER OF SCIENCE IN AERONAUTICAL ENGINEERING

from the

**NAVAL POSTGRADUATE SCHOOL
September 1996**

Author:

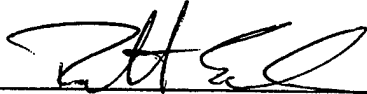

Robert E. Conway

Approved by:

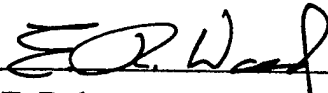

E. Roberts Wood, Thesis Advisor



Richard M. Howard, Second Reader

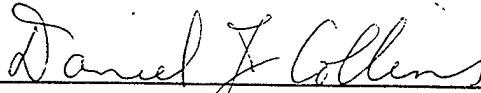

Daniel J. Collins, Chairman

Department of Aeronautics and Astronautics

ABSTRACT

Originally designed as a target drone for the U.S. Army, the NPS *Hummingbird* has undergone several modifications to convert it into a reliable research platform. The 165 pound remotely piloted helicopter (RPH) is powered by a Westlake Aeromarine Engines Limited (WAEL) 342 two stroke, twin cylinder, 25 hp, gasoline engine. An engine failure due to cylinder overheating halted research efforts until investigation as to the cause and subsequent corrections could be made. Costing approximately \$3000 per engine, another failure is unacceptable. The tasks undertaken in this thesis were to investigate the cause of the overheat failure and improve the engine cooling system. Cooling system corrections required total redesigns of the engine cooling and engine start systems. Additionally, research of the RPH's history revealed a need for a torsional shock absorber to be incorporated in the drive train to increase component life. The changes made to *Hummingbird* provide a decrease in empty weight, minimal center of gravity change and, most importantly, an increase in user safety furnishing the Department of Aeronautics and Astronautics with a dependable vehicle for rotary wing research.

TABLE OF CONTENTS

I. INTRODUCTION	1
II. BACKGROUND INVESTIGATION	3
III. BASIS FOR MODIFICATIONS	5
A. STARTER	5
1. Original Configuration	5
2. Starter Deficiencies	6
B. ENGINE COOLING SYSTEM	7
1. Original Configuration	7
2. Cooling System Deficiencies	8
C. DRIVE TRAIN	13
1. Original Configuration	13
2. Drive Train Deficiencies	14
IV. ENGINE BREAK-IN AND TESTING	17
A. ENGINE TESTING SET-UP	17
1. Engine Test Stand	17
2. Hand-held Engine Starter	19
B. ENGINE TEST PROCEDURE	21

C.	ENGINE TEST RESULTS.	22
V.	DESIGN MODIFICATIONS	27
A.	STARTER	27
1.	Design Considerations	27
2.	Starter Design Implementation	28
3.	Starter Operation	33
B.	ENGINE COOLING SYSTEM	33
1.	Design Considerations.	33
2.	Cooling System Design Implementation	34
a.	Cylinder Heads	34
(1)	Upper Engine Mount.	36
(2)	Adapter Installation.	36
b.	Component Removal	38
c.	Cooling System	39
C.	DRIVE TRAIN	41
1.	Design Considerations	41
2.	Shock Absorber Design	41
VI.	GROUND TESTING	45
VII.	CONCLUSIONS AND RECOMMENDATIONS	47

A.	CONCLUSIONS	47
B.	RECOMMENDATIONS	49
1.	RPH Storage	49
2.	UAV Lab Space	49
3.	Complete Implementation of Torsional Shock Absorber ...	50
4.	Power Plant	50
5.	Configure <i>Hummingbird</i> for Forward Flight	50
6.	Main Rotor Head Design	51
7.	NOTAR® Research	51
 APPENDIX A: LIST OF SUPPLIERS		53
 APPENDIX B: POINTS OF CONTACT		55
 APPENDIX C: PRESTOLITE MBJ-4407 PERFORMANCE CHART AND ELECTRICAL SCHEMATICS		57
 APPENDIX D: SPECIFICATIONS FOR DESIGNED PARTS		59
 APPENDIX E: OPERATORS HANDBOOK FOR WAE 342 LIMITED ENGINE SERIES 2100D		65

LIST OF REFERENCES 87

INITIAL DISTRIBUTION LIST 89

LIST OF FIGURES

Figure 1. Original Starting System Configuration	6
Figure 2. Layout of Engine Cooling Components	8
Figure 3. Existing Engine Cooling Cowling	10
Figure 4. Exhaust Manifold Position	11
Figure 5. Right Side View of <i>Hummingbird</i> Without Ventilation Port	12
Figure 6. Main Transmission	14
Figure 7. Engine Test Apparatus	18
Figure 8. WAEL 342 in the Test Configuration	19
Figure 9. Hand-held Starter	20
Figure 10. CHT Comparison for Large and Small Cylinder Heads.	25
Figure 11. Top View of Starter.	28
Figure 12. Bottom View of Starter.	29
Figure 13. Starter Mounted to Landing Gear.	31
Figure 14. Starter Coupled to Engine.	32
Figure 15. Size Comparison of Cylinder Heads.	35
Figure 16. Upper Engine Mount.	37
Figure 17. Spacer Bolt.	38
Figure 18. Cooling Fan and Drive Configuration.	40
Figure 19. Intermediate Shaft of the Main Transmission.	42
Figure 20. Layout of Shock Absorber Components.	44

ACKNOWLEDGMENTS

I wish to acknowledge several key individuals without whose help this project would not have been possible. First and foremost I would like to thank God for the strength and perseverance to get through these last nine months. I would also like to especially thank the Aerospace Engineering Technician Mr. Don Meeks. His knowledge and expertise in UAV's was invaluable to me not having any background at all in model aviation. His dedication shown by working after hours until my work was completed was uplifting. Also deserving my gratitude is Dr. Wood. After all the setbacks and aggravations he was always there to help me gather myself back together, sort out the problem and move on. I would also like to thank my family for providing me with encouragement and understanding during the trying times of my thesis research. Finally, a general thank you to all those who I pestered as I used them as sounding boards for my ideas and theories.

I. INTRODUCTION

Recent achievements of the Naval Postgraduate School's Aeronautics and Astronautics Department in helicopter research have emphasized the importance of the work done here. The outstanding performance of NPS design teams in the American Helicopter Society's annual helicopter design competition, valuable student and staff research and exposure in local media and professional publications have positioned the Aeronautics and Astronautics Department as a leader in helicopter research. Among the many resources of the department is the NPS *Hummingbird*, part of the remotely piloted helicopter (RPH) research program. The *Hummingbird* is a unique rotary wing aircraft that possesses characteristics well suited for scale model research in Higher Harmonic Control (HHC), NOTAR[®], and other rotary wing fields. To date there have been at least three inquiries from outside sources for future experimentation on the NPS *Hummingbird*. In order to comply with these and other requests, several design deficiencies have been corrected to bring the aircraft from its original configuration as a target drone to its current status as a reliable rotary wing test platform.

Thus far, necessary design modifications to the airframe, main rotor and transmission have been completed and implemented in order to have a reliable RPH suitable for quality research. Due to an overheat failure of one of the *Hummingbird's* two inventory Weslake Aeromarine Engines Limited (WAEL) 342 engines, ground and flight testing was halted until an investigation as to the cause of the overheat and subsequent corrections could be made. The WAEL 342 engine is a 342 cc, two-stroke, simultaneously firing, twin cylinder

gasoline engine produced by Target Technology Ltd. in the United Kingdom. It possesses a maximum power rating of 25 hp at a rated speed of 7000 rpm and a maximum torque of 24 ft-lb at 4000 rpm. It is an ultra-lightweight power plant designed, developed and manufactured specifically for remotely piloted vehicles (RPV) and unmanned aerial vehicle (UAV) installations. The scope of the following research is to investigate current power plant deficiencies and to provide adequate solutions for effective engine cooling and drive train reliability in order to avoid future costly delays in RPH research.

Modification of the engine cooling system included increasing engine cylinder heat dissipation and improving interior fuselage ventilation. To facilitate the cooling system improvement a redesign of the engine starting system was implemented which allowed for a significant increase in payload capability and a decrease in gross weight while, most importantly, increasing user safety. A drive train modification consisting of the design of a torsional shock absorber was also required to prolong the life of the drive train and main rotor components by protecting it from observed engine torque impulses. The ultimate goal of this study was to modify the current power plant and drive train to provide sufficient power and maximum airframe dependability and safety while keeping gross weight changes, center of gravity shifts and modification costs to a minimum.

II. BACKGROUND INVESTIGATION

In order to effectively trouble shoot the engine cooling problems, it was first necessary to obtain information about the WAEL 342 engine. There was no supporting documentation except an engine operators manual which was included with the RPH and spare parts from Mr. John Gorham, the original designer. The engine operator's manual had a company name, Weslake Aeromarine Engines Ltd. in the United Kingdom, but no address or other points of contact. Investigation began by tracking down the engine listing in the 1980-1981, 1981-1982 and 1982-1983 editions of Janes' All the World's Aircraft. Weslake Aeromarine was the company that built the engine as of that year and a telephone call was put through to find out more, current information. It was learned that Weslake was bought out and included as subdivision of the company Normalair-Garrett Ltd. who had sold the manufacturing rights of the WAEL 342 to a company named Target Technology Ltd., also in Great Britain. Information concerning the engine's performance, cost and support was requested from this company and received via facsimile.

The engine documentation stated that the WAEL 342 engine was designed for external use only in air streams of approximately 150 kph or 93 mph. This definitely meant that some sort of cooling system designed specifically for the *Hummingbird's* internal use was required. The fax also contained information on engine performance and a larger cylinder head that was used for improved cylinder cooling purposes. Included price information made it absolutely clear that purchasing a replacement engine was to be a last

resort. A thirty day price quote on 25 April 1996 put the WAEL 342 at £1855.85 or \$2969.36 per unit for a quantity of one to nine engines.

An American affiliate of Target Technology Ltd. was also listed in the fax. Southwest Aerospace in Tustin Ca. was contacted to find out more information about the WAEL 342. A Mr. Ian Matyear was able to provide data on purchasing the WAEL 342 engine and its components. He also provided another source of information, Mr. Ken Beckman, who had vast experience with similar size RPH's. Mr. Beckman proved to be an invaluable source of information as he was quite familiar with the *Hummingbird's* original design. During the RPH's initial development as a target drone for the U. S. Army, Mr. Beckman reported on the status of this project to Boeing Aircraft Company, the primary contractor, as to the progress of the subcontractor, Gorham Model Products. He mentioned that the cooling system installed was an after thought as engines before had failed due to overheating and also described many of the other deficiencies as they had existed prior to NPS student's modifications. He also mentioned that there existed "wild" torque fluctuations in the engine and that there was a possibility of main rotor and drive train damage and, most importantly, a potential safety hazard. Reports of engine runaway and main rotor separation due to excessive shock and vibrations were among his so told cautions. He suggested that some sort of torsional shock device be installed to remedy this situation.

In all, the above investigation proved to be very necessary and of great benefit in providing adequate solutions to the current problems. Mr. Beckman's information and advice from his first hand experience with this RPH was an inestimable value to this project. The above sources will be of great help throughout the life of the *Hummingbird* program.

II. BASIS FOR MODIFICATIONS

As previously stated, in order to successfully modify the *Hummingbird's* engine cooling system it was necessary to include improvements and redesigns of the starting, engine cooling and drive-train systems. Investigation of the *Hummingbird's* history, both prior to and after the Naval Postgraduate School's acquisition, and close inspection of the drive-train layout yielded observation of several design weaknesses. The following is a discussion of the deficiencies in the original power plant and drive train configurations.

A. STARTER

1. Original Configuration

The original starter was a permanent attachment to the *Hummingbird*. The starter motor was a 12 volt electrical motor which was hard-mounted to the airframe close to the forward engine cylinder. The starter motor shaft was fitted with a 1 inch diameter sprocket which drove another 7 inch sprocket through a chain drive providing a 7:1 mechanical advantage for the starter motor. A one-way bearing on the 7 inch sprocket provided for starting force in the counterclockwise direction and freewheeling in the clockwise direction as viewed from the top of the RPH. Two DC power cables ran from positive and negative cable receptacles in the left side of the forward fuselage to the starter motor. Figure 1 shows this configuration.

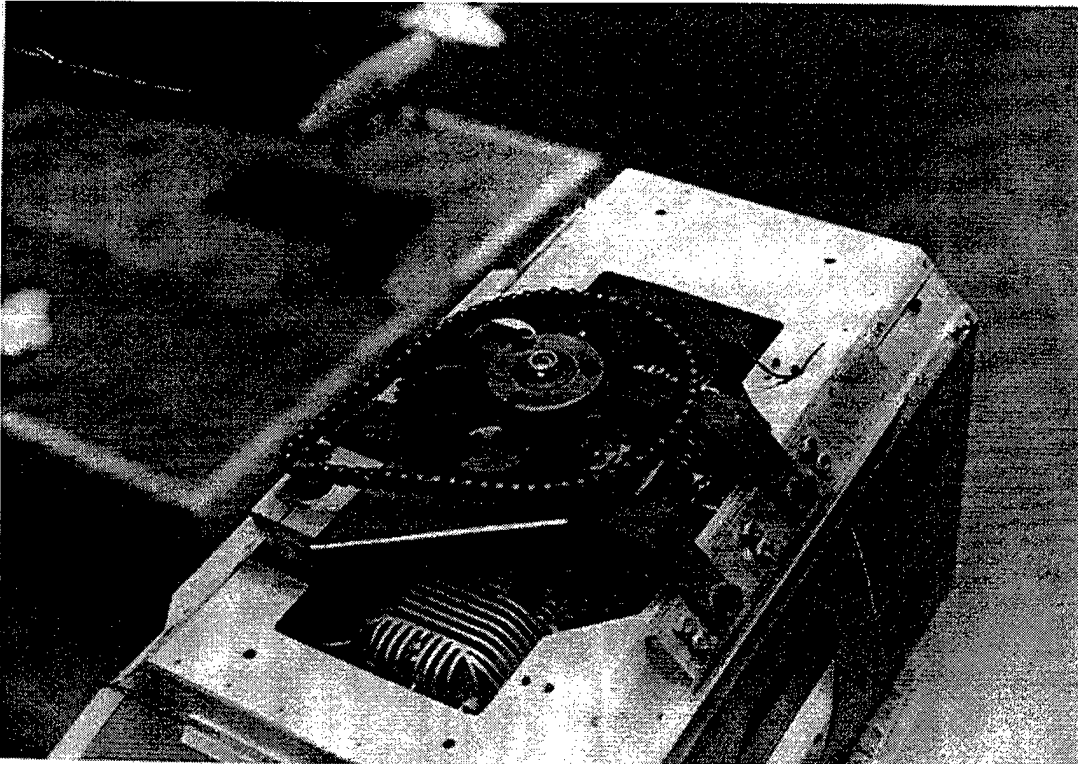

Figure 1. Original Starting System Configuration

To start the *Hummingbird*, external power cables were hooked up to a 12 volt automobile battery which provided power to the starter motor. Once achieving a starting rpm of approximately 1000 rpm the WAEL 342 cc gasoline engine ran independently. The external power cables then had to be physically pulled out of the receptacles from approximately ten feet away.

2. Starter Deficiencies

The starter motor was found to be under powered. Prior starting attempts required two fully charged 12 volt marine batteries connected in series (24 volts total) for the electric motor to provide enough starting torque to the engine. This configuration ran the risk of burning out the starter motor and causing an electrical fire on the airframe.

Removal of the power cables risked entanglement of the cables in the main rotor system as the cables were free to whip as they were pulled from the fuselage. The main rotor arc extends 5 feet from the rotor hub and sits approximately 3 feet off the ground. Entanglement of the cables is an unnecessary risk to the program and a safety hazard.

The starter motor and its associated hardware weighs approximately 8 pounds or approximately five percent of the *Hummingbird's* advertised gross weight. Elimination of this weight would provide an attractive thirteen percent increase in payload capability or compensate for the weight of the modifications.

Finally, the starter which was mounted very close to the forward engine cylinder and the 7 inch sprocket mounted on the lower engine drive shaft restricted cooling air from flowing smoothly over the cylinder's heat fins. A fiberglass cowling that directed airflow over the engine had to be modified by cutting away an approximately 3x5 inch section in order to accommodate the starter motor installation which reduced the engine-cooling system efficiency.

B. ENGINE COOLING SYSTEM

1. Original Configuration

The configuration of the engine-cooling system was as follows. A 6 inch diameter vane-axial impeller was mounted to the engine drive shaft which rotated at speeds between 3000 and 7000 rpm. A crudely manufactured cowling was installed over the engine and impeller with the top of the impeller exposed just above the cowling. The cowling was constructed of fiberglass and fit closely around the engine. A make-shift diffuser, similar to those found in smaller scale model helicopter cooling systems, was molded into the top

of the cowling to provide an increase in pressure to reduce losses in the system. The air was directed out the bottom of the fuselage and into the atmosphere. Figure 2 shows the layout of the cooling system components.

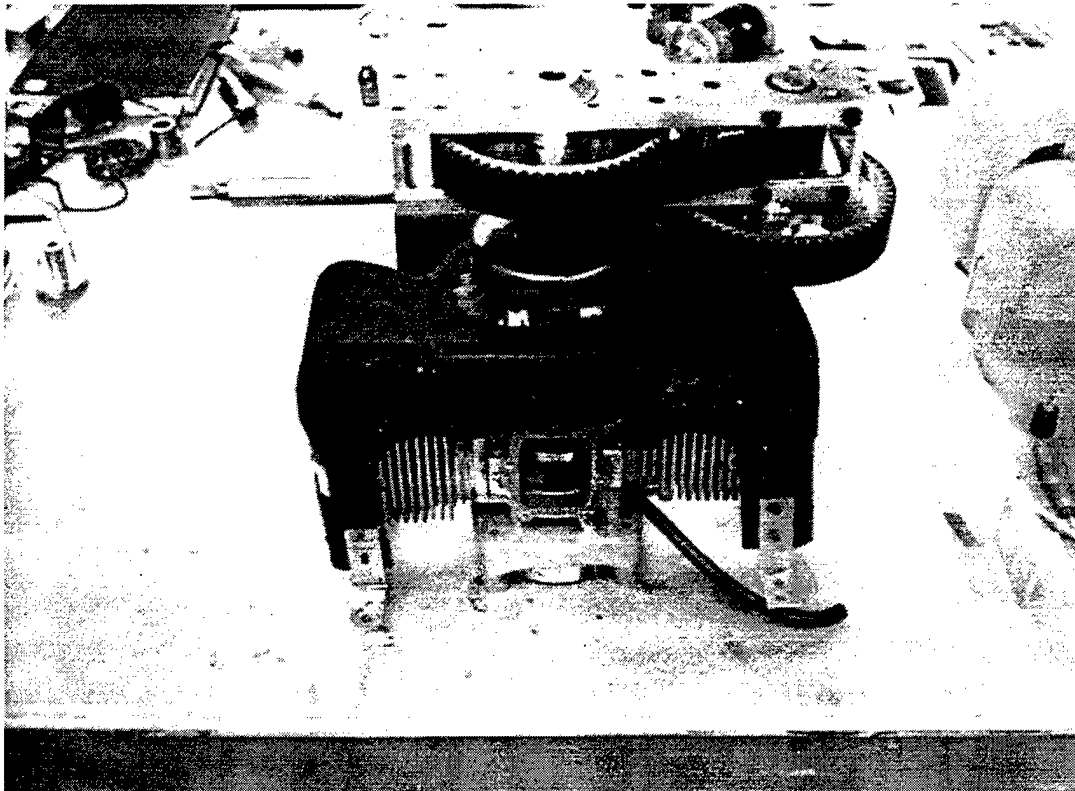

Figure 2. Layout of Engine Cooling Components

2. Cooling System Deficiencies

The original design of the *Hummingbird's* engine-cooling system was proven inadequate by failure of the engine due to overheating. The engine manual states that the maximum cylinder head temperature measured at the spark plug gasket is not to exceed 482° F and maximum exhaust gas temperature is not to exceed 1022° F. Upon inspection of the

failed engine, deep scoring was found in both cylinders. The pistons were locked into the cylinders and unable to be removed. Deposits of metal were also found fused to the cylinder walls pointing to a massive overtemp of the engine.

A partial reassembly of the power plant and drive train provided clues to the overheating problem. The engine manual specifically states:

CAUTION:

THE ENGINE IS AIR COOLED AND MUST NOT BE RUN IN STATIC CONDITIONS UNLESS AN ADEQUATE COOLING AIRFLOW IS SUPPLIED. MAXIMUM CYLINDER HEAD TEMPERATURES MUST NOT BE EXCEEDED.

The "cooling air-flow" was insufficient for the following reasons. First the cooling system was designed to draw air in to the center of the engine and then to direct it out along the cylinder. The cooling fins were perpendicular to the direction of flow causing the airflow to be disrupted as it moved further away from the center of the engine. Sufficient airflow to the cylinder head was therefore not available. A significant amount of the fiberglass cowling that directed the airflow over the engine had also been trimmed away to accommodate the starter and exhaust components. In order to mount the starter an approximately 3x5 inch square had to be removed. Other cut-outs for the engine exhaust, decompressors (small ports mounted on both cylinder barrels to aid in engine ignition) and mounting hardware, shown in Figure 3, had widdled away at the intended design rendering this component ineffective.



Figure 3. Existing Engine Cooling Cowling

One of the main contributors to the cooling problem was the engine exhaust system. The exhaust system consisted of an exhaust manifold and a 12 inch long, 1 ½ inch diameter flexible steel tube. The manifold collected exhaust from both cylinders and provided limited noise muffling. The manifold is constructed of stainless steel with an attachment for the flexible tube in the rear. The tube ran from the manifold, around the rear of the engine and exited from the bottom of the fuselage. The maximum allowable cylinder head temperature is 482 °F and the maximum allowable exhaust gas temperature is 1022 °F. As will be discussed later, average observed exhaust gas temperature with proper fuel-air mixture is 600 °F to 700 °F. The manifold and exhaust pipe were radiating 600 °F to 700 °F over 182.7 square inches inside a mostly enclosed fuselage with virtually little outside air entering the

fuselage interior during ground runs aside from an insignificant amount of main rotor wash. The exhaust manifold was also positioned just 2 inches from the intake of the cooling fan as seen in figure 4.

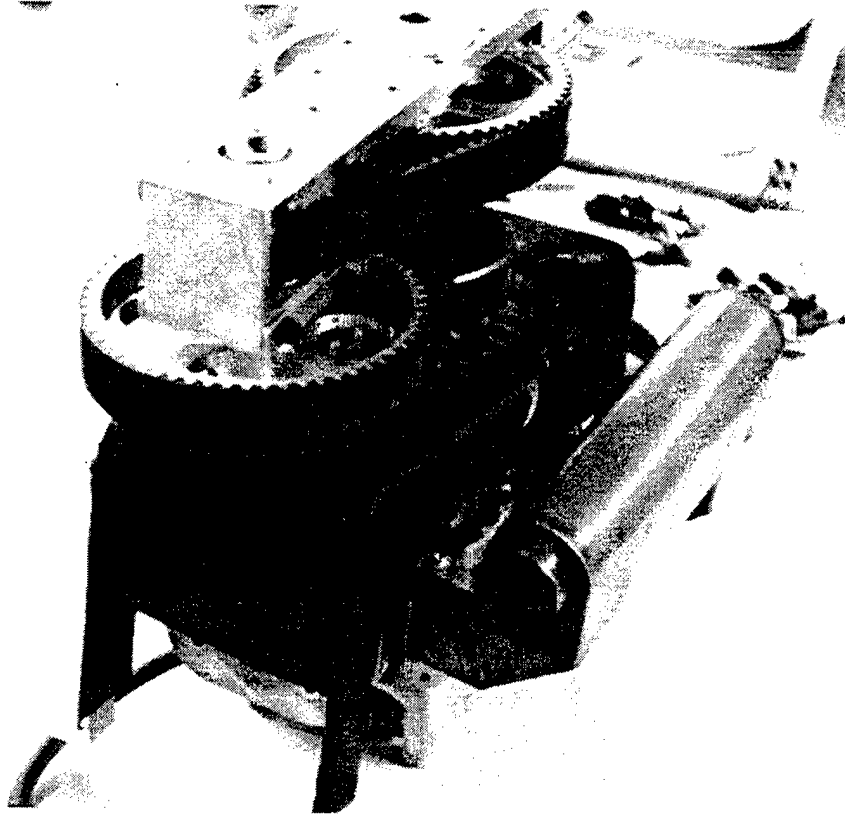

Figure 4. Exhaust Manifold Position

The result was an intake of cooling air with an equal or higher temperature than the maximum cylinder head temperature.

Prior ground tests of the *Hummingbird* at NPS were conducted with the fiberglass front body shell off to allow the maximum heat dissipation and ventilation possible. Photographs of RPH's similar to the *Hummingbird* show ventilation holes cut in both sides of the front body shell. The *Hummingbird*, however, only had one hole cut in the left side. Figure 5 shows a right side view of the RPH with no ventilation hole cut in the fiberglass

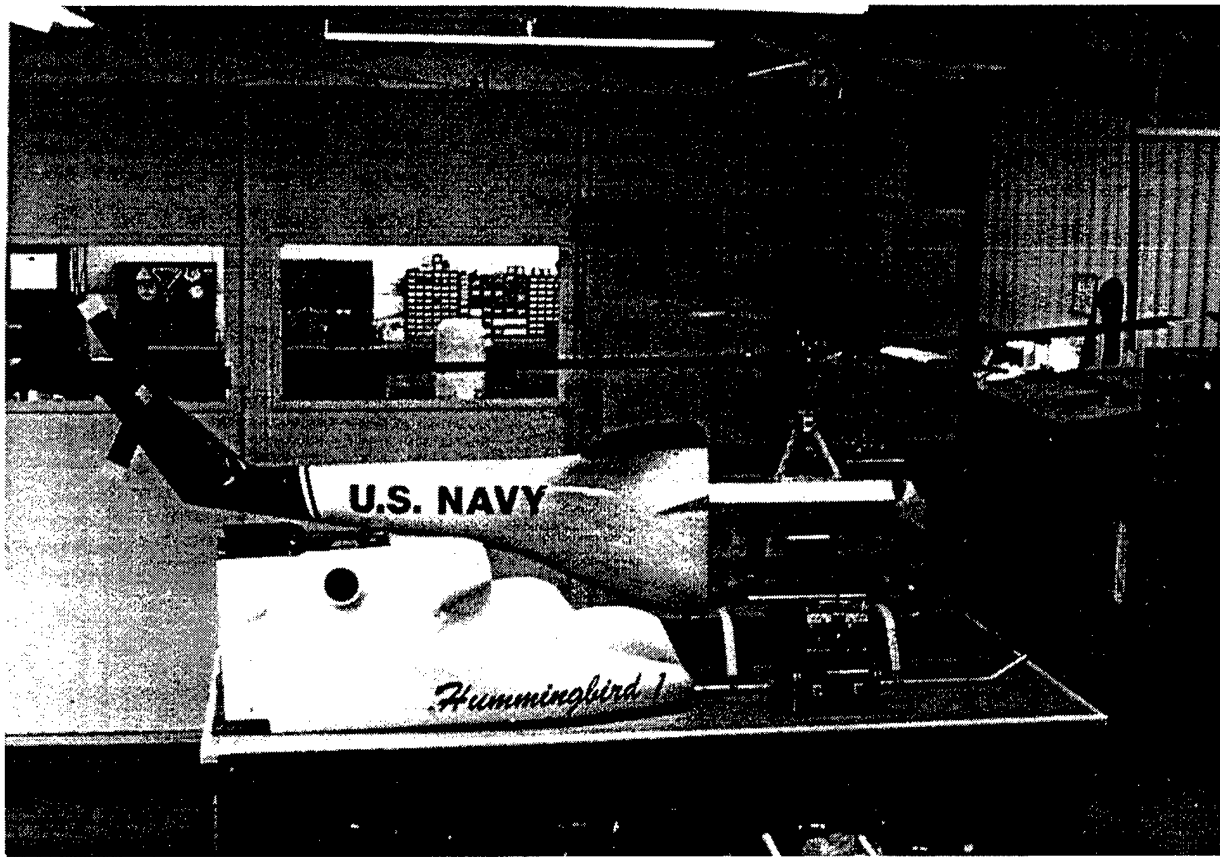

Figure 5. Right Side View of *Hummingbird* Without Ventilation Port body shell and the exhaust manifold's position just inside the fuselage. The solid fiberglass shell on right side allowed a build up of the exhaust manifold temperature which could have further increased the cooling air temperature at the intake of the cooling fan. The object seen in the hole in the fuselage in Figure 6 is the exhaust manifold.

One final cause of overheating was an improper engine operation and improper adjustment of the engine's fuel mixture in the carburetor. The engines received from Gorham Model Products had no information as to total engine time and previous carburetor adjustment settings. The damaged engine was most likely a new engine requiring a two hour break-in period which was not accomplished. The carburetor's high and low speed needle

jets, initially set at the factory and possibly moved during shipment, were not checked for proper adjustment. Cylinder head and exhaust gas temperatures were seen to vary a great deal ($\pm 100^\circ$ for cylinder head and $\pm 150^\circ$ for exhaust gas temperature) during the engine break-in period carburetor adjustments. Thus, maladjustment of the carburetor settings can very easily cause an overheat problem.

C. DRIVE TRAIN

1. Original Configuration

The drive train begins at the engine drive shaft. The vane-axial cooling fan and centrifugal coupler were mounted on a shaft extension and a drive pulley is attached to the top of the centrifugal coupler. A drive belt connects this pulley to an intermediate shaft to which a sprague clutch is mounted for autorotational capability. Another belt drive is connected to a pulley which is keyed to the main rotor shaft. The tail rotor take-off is driven by bevel gear mounted to this pulley. Total gear reduction is 10:1 from the engine to the main rotor shaft and 3.2:1 to the intermediate shaft. The tail rotor drive shaft turns at 40% of the engine shaft speed. Figure 6 shows the main transmission layout.

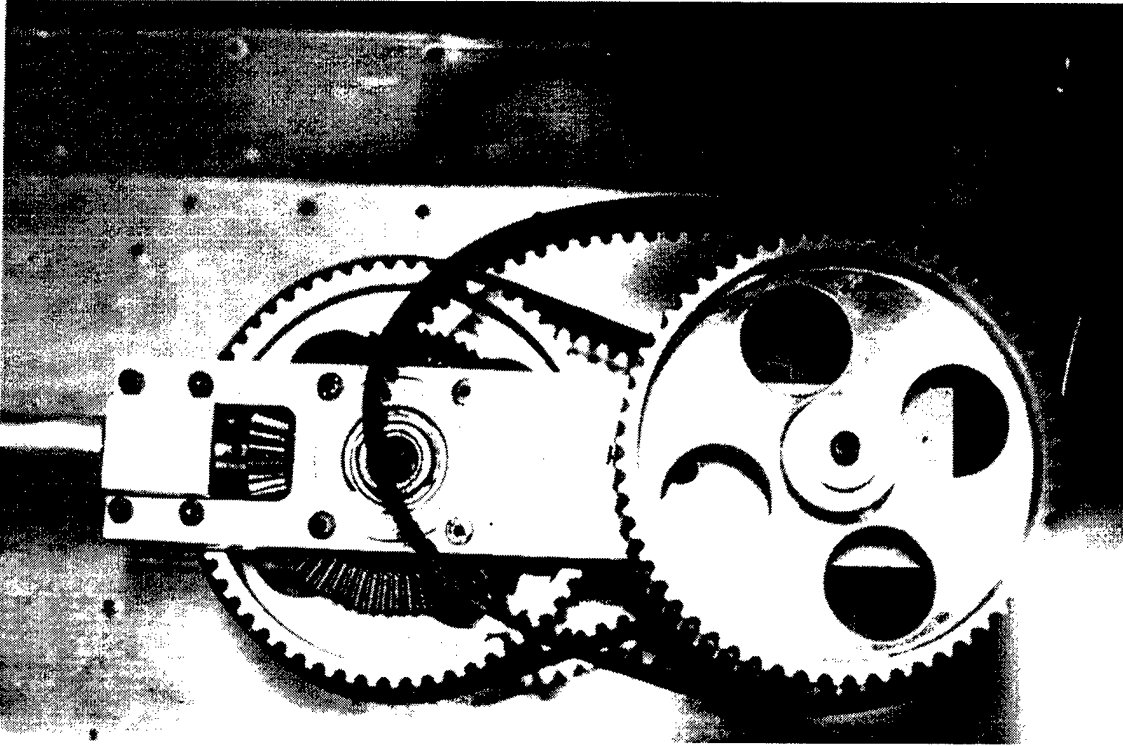

Figure 6. Main Transmission

2. Drive Train Deficiencies

As mentioned in the background investigation chapter, massive torque fluctuations due to unsteady idle speeds exist. These torque fluctuations were reported to, however unverified, snap the main rotor shaft of a similar RPH. In any case, fluctuations in engine torque are magnified ten times at the main rotor shaft due to the 10:1 mechanical advantage given by the transmission. With the exception of the hard rubber belts and limited slipping in the centrifugal coupling, there is nothing to absorb any sort of shock caused by torque

fluctuation in the unmodified drive train. The incorporation of a shock absorber was determined necessary in order to prolong drive train component life and reduce airframe vibrations.

IV. ENGINE BREAK-IN AND TESTING

The engine tested was a brand new WAEL 342 with no operating time accumulated. The engine manual requires a two hour break-in period before it is put to any application. A break-in schedule consisting of several low power runs at short time durations (5-10 minutes in length) and varying power runs at longer time intervals was conducted. In conjunction with these runs, engine cylinder head and exhaust gas temperatures (CHT, EGT) were monitored to determine the relationship between power and the measured temperatures, allow the correct setting of the high and low speed needle jets on the carburetor and provide clues as to how to contain the temperatures while mounted inside the helicopter's fuselage.

A. ENGINE TESTING SET-UP

1. Engine Test Stand

The engine was mounted on a test stand designed to measure thrust and rolling moment of the AROD UAV. The rolling moment was the only measurement taken and allowed the determination of engine power. Thrust measurements were not needed for the performance calculations. The moment was computed by reading a force gage which was mounted at the end of a 9 inch moment arm, as seen in Figure 7, and then converted to horsepower after obtaining engine rpm by a strobe tachometer. To provide a working load during the testing and break-in procedures a 30 inch diameter birch propeller (commonly used in ultra light aircraft applications) was installed. Figure 8 shows the engine rigged for testing. The direction of rotation of the engine was opposite to the direction of rotation of

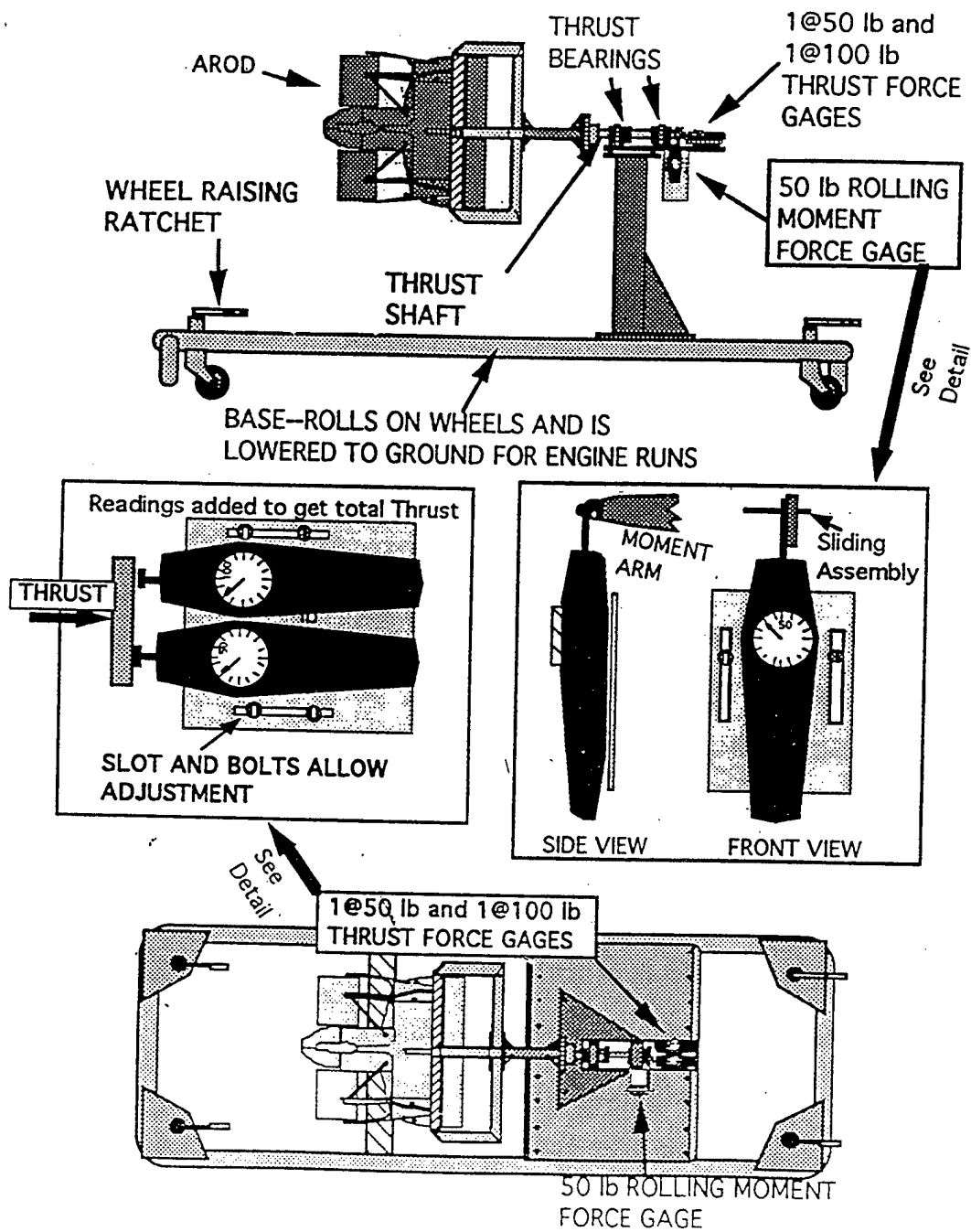

Figure 7. Engine Test Apparatus

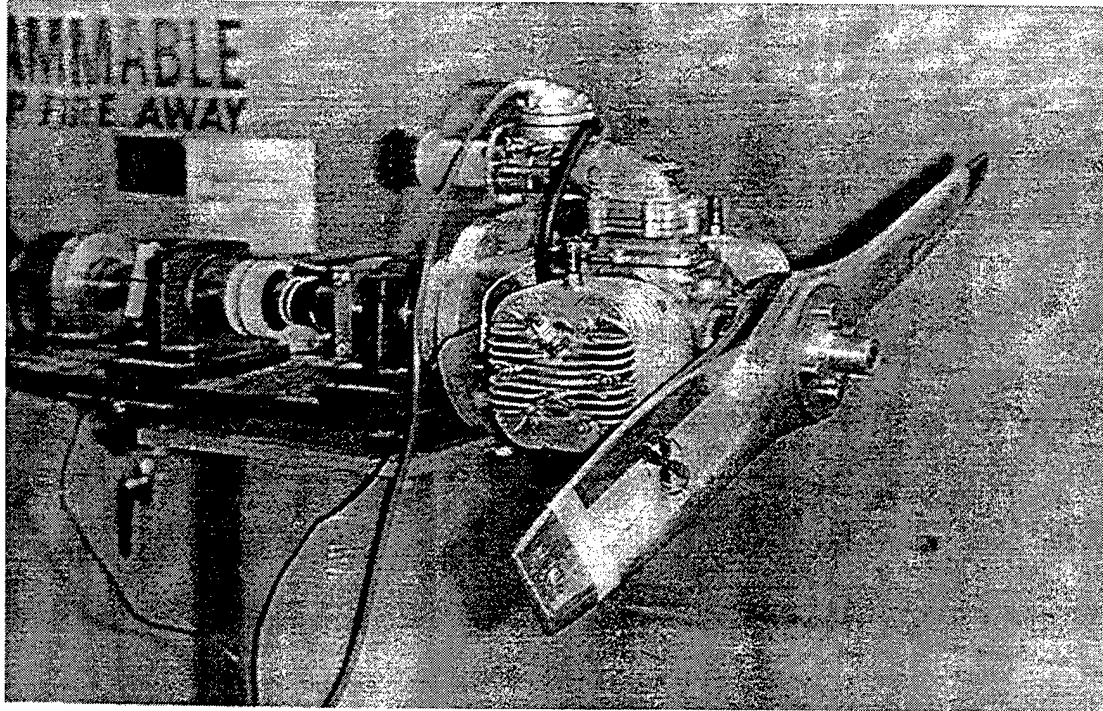

Figure 8. WAEL 342 in the Test Configuration

the propeller. For this reason the propeller had to be mounted backwards. A one gallon fuel tank provided a 25:1 fuel-oil mixture to the engine. As a precaution a 24 inch diameter room fan was placed to direct airflow over the engine. This later proved to be ineffective.

2. Hand-held Engine Starter

The engine was started by a hand-held starter which contained a new starter motor shown in figure 9. With the need to start the engine in a counter-clockwise viewing the engine from the rear on the test stand, a starter with this rotation was sought. Also at this

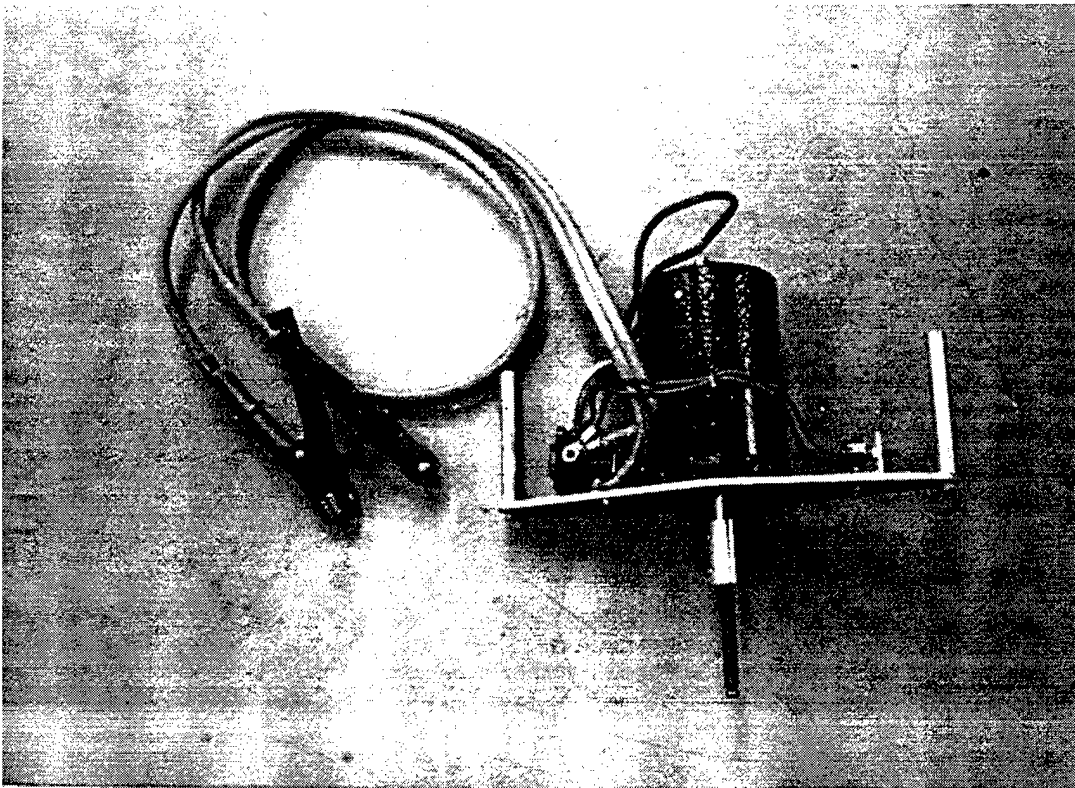

Figure 9. Hand-held Starter

stage of the research the direction of rotation of the external starter design had not yet been decided. Therefore a starter with the capability of providing adequate torque in both directions was prudent. The Prestolite MBJ-4407 winch motor was chosen for its availability, power and dual directional capability. The performance specifications for this motor can be found in appendix C.

The coupling of the starter to the engine shaft was accomplished through the use of a hex-ball wrench on the starter and a hex-socket bolt mounted to the propeller. The hex-ball gives the advantage of providing constant torque while allowing small misalignments of the starter shaft. The hex-ball also does not jam into the socket which becomes a large

safety feature when hand starting a 25 hp engine. A 3/8 hex-ball was pressed into a cylindrical block of aluminum. The bottom half of this 2 inch block was bored to fit the starter motor's 3/4 inch drive shaft. The wrench coupling was then pinned to the starter motor shaft. A mounting plate for the starter motor, a momentary contact switch, solenoid and two handles were fabricated and the above components assembled. A set of automobile jumper cables was modified by adding eye terminals to one set of ends of the jumper cables. The electrical connections were then wired to the assembly in accordance with the supplied wiring diagram. The hand-held starter is shown in Figure 10.

Thermocouples were placed at the exhaust pipe and sparkplug to measure the EGT and CHT, respectively. The thermocouple leads were connected to a digital readout which displayed the two temperatures on two separate channels. Tests were conducted in static air conditions with the only air flow over the cylinders being a low velocity induced flow caused by the propeller. With the reversed mounting of the propeller, the induced air flow was drawn over the engine cylinders and thrust forward. Finally, a "kill" switch was installed to ground the electrical connection from the magneto to the spark plugs enabling controlled engine shutdown.

B. ENGINE TEST PROCEDURE

For each day of engine testing, the ambient air temperature was recorded. The safety procedures in the engine manual were then reviewed. The engine starting checklist also in the engine manual was then followed for engine start. The starter rig was connected to a 12 volt marine gel-cell battery via the jumper cables and the hex-ball wrench drive was

inserted into the hex socket on the propeller's hub. The switch on the starter was thrown and the starter held in place until the engine fired. Once running the engine temperatures were recorded at various engine rpm.

C. ENGINE TEST RESULTS

Although ambient air temperatures were recorded for each day of engine operation, the difference in the temperatures from day to day was proportionally insignificant to the recorded engine temperatures. Therefore all engine temperature information assumes an average ambient temperature of 65 °F.

The first engine run was conducted only to start the engine for break-in and to observe the engine and engine temperature behavior. Minor carburetor adjustment was made to obtain behavioral information also. This run revealed an idle rpm of about 3100 rpm and idle cylinder head and exhaust temperatures of 235°F and 594°F, respectively. A maximum throttle setting was briefly set. This power setting showed a maximum rpm of 4400, a maximum exhaust gas temperature of 618°F and a cylinder head temperature that would have greatly exceeded the 482°F maximum if left to continue operating. This power regime displayed evidence of the overtemp experienced by the failed engine and a requirement for cylinder cooling.

Seeking a balance between temperature limits and reducing engine operating roughness, the high speed needle jet on the carburetor was set to minimize maximum power cylinder head temperature through a slightly rich air-fuel mixture and minimize roughness at idle throttle settings through a slightly lean mixture. The needle jets were adjusted by rotating them by 1/8 th of a turn and noting the results until a favorable condition existed.

The WAEL 342 is rated at 25 hp maximum power at 7000 rpm. After calculating the brake horsepower from the torque reading it was determined that the engine was delivering maximum power due to the propeller load at 4400 rpm. Until the final carburetor settings were achieved, the CHT and EGT were seen to vary as much as 100 °F and 150 °F, respectively. Subsequent runs on the engine began to show consistent temperature behavior with proper carburetor adjustment. The chart below shows the typical results for the properly adjusted engine.

Typical CHT and EGT at Various Engine RPM

RPM	CHT (°F : 482 °F Max)	EGT (°F : 1022 °F Max)
3100 (idle)	233	602
3700	322	615
4000	378	611
4400 (full throttle)	Exceeded limit	625

The maximum cylinder head temperature was unable to be contained but was reduced to a slow creep through 482°F. The room fan use was discontinued after noticing that there was no difference in cylinder head temperature with or without the fan running. The engine exhausted the one gallon fuel supply in 35 minutes putting the fuel consumption rate at 11.7 lb/hr which is consistent with the engine performance data provided by Target Technology Ltd..

To see the effects of forced air over the cylinder a backpack-type leaf blower was borrowed from the greens keeper shack at the NPS golf course. The blower provided an advertised 150 mph air flow through a 4 square inch opening at full throttle. At a full

throttle setting on the WAEL and a mid to full throttle setting on the blower, the CHT was contained well below 482°F at approximately 420 - 450°F. The results of this experiment revealed that it was possible to contain the temperature through a forced air device.

A pronounced torque fluctuation as described by Mr. Beckman was also evident. These fluctuations were load driven as they were seen to be more pronounced at low loads at lower rpm than at high loads. The fluctuations could not be determined during engine operation due to the test configuration; however, once the engine was shut down telltale scoring on the scale face showed an approximate ± 10 ft-lb fluctuation at idle power and ± 1 to 2 ft-lb fluctuations at full power. This multiplied by the 10:1 mechanical advantage provided by the transmission can mean a ± 100 ft-lb fluctuation at the main rotor mast. This observation confirmed the torque fluctuation claims of Mr. Beckman.

During the engine testing phase the oversized cylinder heads were received. Several modifications to the engine had to be made in order to accommodate the increased size of the heads. The spark plug wiring had to be lengthened to reach over the new head to the spark plug. A spark plug cap retainer had to be manufactured to keep the spark plug cap from sliding off the longer plugs due to the engine vibrations. Finally, longer cylinder head bolts were installed to compensate for the increased head thickness. Once the new cylinder heads were installed, the engine was run to observe the effects of the increased area on CHT and EGT.

The engine was again tested in static air conditions. Runs initially at idle power settings showed an approximate 25°F decrease in CHT and, as expected, no change in EGT. Runs at maximum throttle showed a maximum CHT of 435°F. The effect of the increased

area of the cylinder head reduced the maximum CHT by over 47°F in static conditions. A comparison of the EGT and CHT observed with the two sizes of cylinder heads is shown in Figure 10.

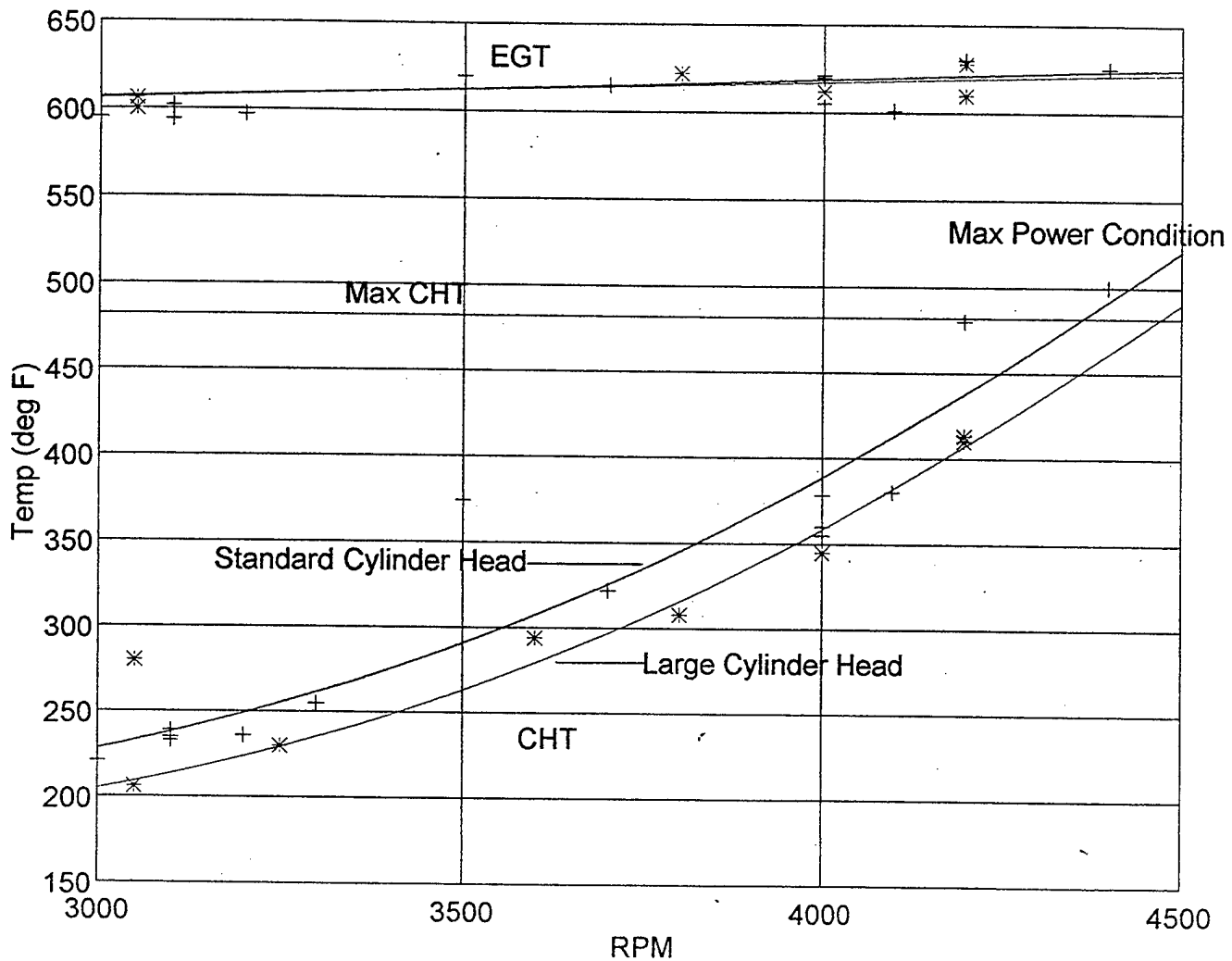

Figure 10. CHT Comparison for Large and Small Cylinder Heads

This determination moved the cooling system design away from a high mass flow system to an interior ventilation or low mass flow system in which the induced air flow velocities over the engine on the test stand would be matched or increased inside the fuselage.

The engine break-in was accomplished without incident and approximately 3 hours and 20 minutes of engine operating time were accumulated. The engine performance information provided by Target Technology Ltd. was also verified as being consistent with observed engine performance. Most importantly it was shown that the larger cylinder heads provided enough heat dissipation to contain the maximum CHT at full throttle settings in static air conditions.

V. DESIGN MODIFICATIONS

The following modifications were made in order to overcome the previously discussed deficiencies. The general design constraints throughout were to minimize complexity, minimize weight and CG changes, minimize cost and increase user safety.

A. STARTER

1. Design Considerations

Looking at its airflow obstruction effects and inability to perform reliably, it was decided to completely redesign the engine starting system. A major factor considered along with overcoming the existing deficiencies was the requirement to start the engine on the UAV test stand. Most UAV engines including the WAEL 342 in a fixed wing application need a counterclockwise torque for start. However, due to mounting constraints on this test stand, a starter must be able to provide starting torque in a clockwise direction as one faces the propeller. This demonstrated early on in the design that a starter capable of providing torque in both directions would be practical.

As mentioned earlier, removal of the starting system's eight pounds would provide an attractive 13% increase in payload weight or compensate for the weight of the modifications. This benefit coupled with an assured starter motor weight increase due to the increased power requirement and dual direction capability drove the starter system redesign to an external configuration.

Along with the external design requirement was the need to accomplish an engine start remotely and not to have the starter interfere with flight operations. Some sort of drop

away device would be useful and would allow the starter assembly to be removed from the operating area safely without possibility of main rotor entanglement or other interference. The final design provides a starter capable of starting *Hummingbird* on the ground for flight operations or on a test stand such as the one acquired in LT Booth's thesis [ref. 5].

2. Starter Design Implementation

The starter assembly's final design is as shown in Figures 11 and 12. It consists of a 0.25" x 9" x 20" base plate to which the driving components are mounted. The starter motor is the 12 volt Prestolite MBJ-4407 winch motor used in the hand held starter. A 1:1 drive ratio was proven effective by the hand held starter during the engine tests. Originally

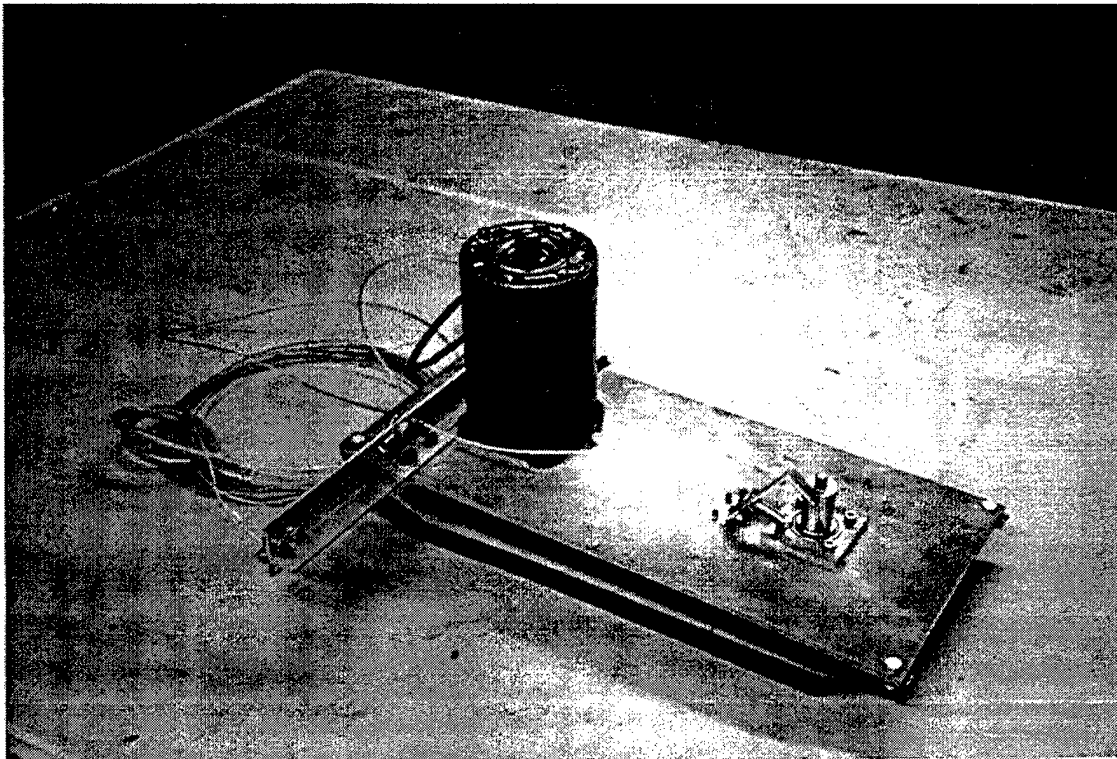

Figure 11. Top View of Starter

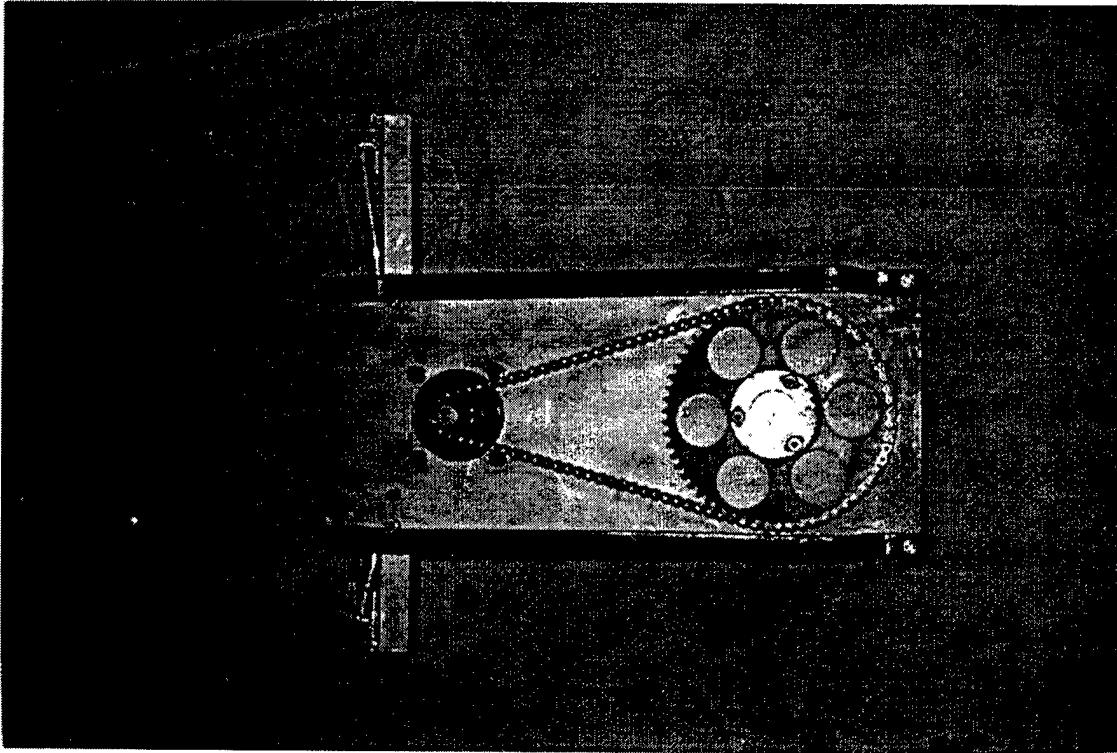

Figure 12. Bottom View of Starter

the motor was mounted as follows. The starter motor mounts to the plate with the drive shaft passing through the plate from top to bottom. A 7 inch sprocket taken from the spare *Hummingbird* parts is mounted to the end of the shaft. An insert for the sprocket had to be designed and manufactured to replace a one-way bearing of the original design to eliminate any slippage. A chain drives another 7 inch sprocket which is mounted to the engine starting drive shaft. This sprocket contains a one way bearing which allows for torque application during start and freewheeling when the engine rpm exceeds the starter rpm. The original insert for the one way bearing was designed for the tapered shaft that mounted to the bottom of the engine by means of friction only which caused some damage due to metal-to-metal

slippage. A new piece was designed and manufactured to accommodate a straight shaft and key. The sprocket is attached to the drive shaft which passes upward through the plate. A 3/8 inch hex-ball drive wrench is pressed into an adapter which rides on a thrust bearing to prevent excessive wear of the starter drive shaft components. The ball drive wrench again gives the benefit of allowing small misalignments which occur during engine start and allows the starting assembly to drop free of the structure without jamming in the drive socket. The thin neck of the wrench is also the most convenient place for the starter to structurally fail should normal starting forces be exceeded.

In an initial functional test of the starter in the above configuration it was shown that there was insufficient power to turn the engine drive shaft. At best the starter was turning the engine at 60 rpm well short of the 1000 rpm called for in the engine specifications. A mechanical advantage similar to the one seen in the previous starter design was then incorporated. A 1.4 inch diameter sprocket, seen in Figure 12, was obtained and installed providing an approximate 5:1 mechanical advantage. A functional test on the starter in this configuration showed adequate rotational speed for engine start.

A 3/8 inch impact socket is mounted to the bottom of the engine. To mount this socket, the original tapered mounting adapter which provided for attachment of the 7 inch sprocket to the engine shaft was machined from the original tapered shaft to a 1/2 inch drive socket wrench mount.

The starter is held in place at four points shown in Figures 13 and 14 keeping entirely off the ground when attached for engine start. The first two are on each landing gear strut. Two pins and mechanical stops prevent fore and aft as well as lateral movement. These two

pins are connected by a spring so that both pins release after an over-the-center lock is cleared. The third point is the 3/8 inch hex ball socket which limits horizontal planar movement when coupled to the engine. The fourth point is a spring-loaded latch assembly connected to a cross bar under the engine which keeps the starter coupled to the engine during start. Two 30 foot lengths of small diameter cable are connected to the assembly which allows starter disengagement and towing the assembly clear of the operating area. Skids are installed to pull the assembly clear. The skids are formed with a semi-circular protrusion on the front. This feature unloads the 20 pound weight on the pins that hold the

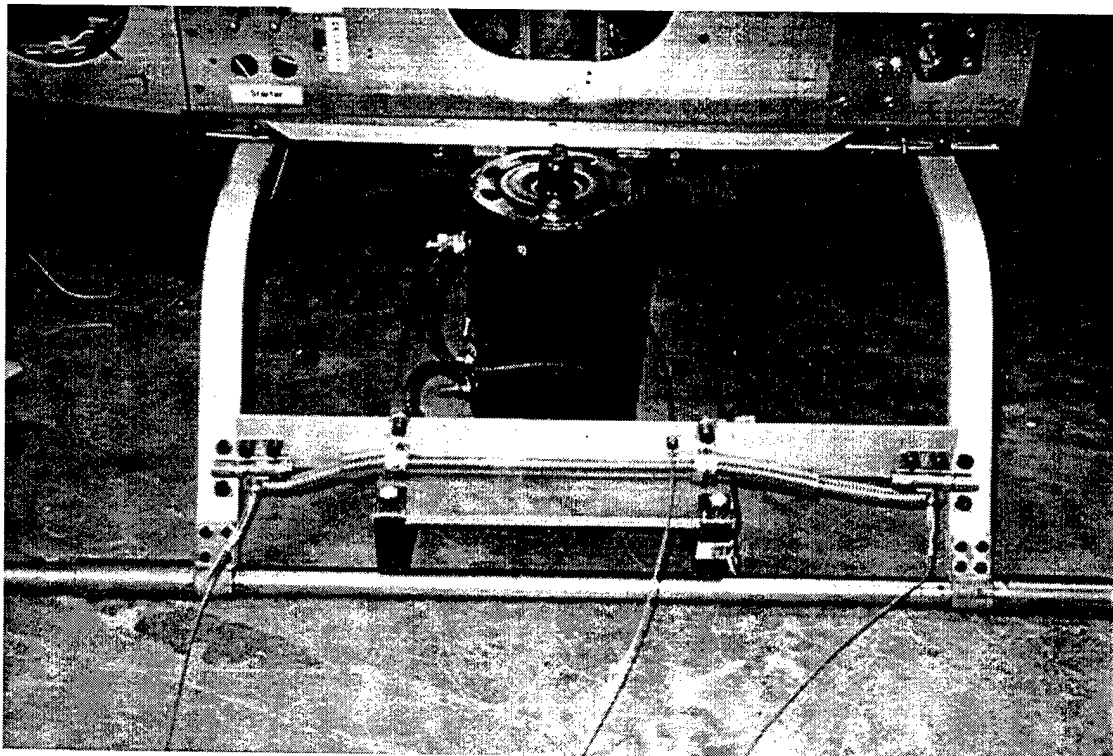

Figure 13. Starter Mounted to Landing Gear

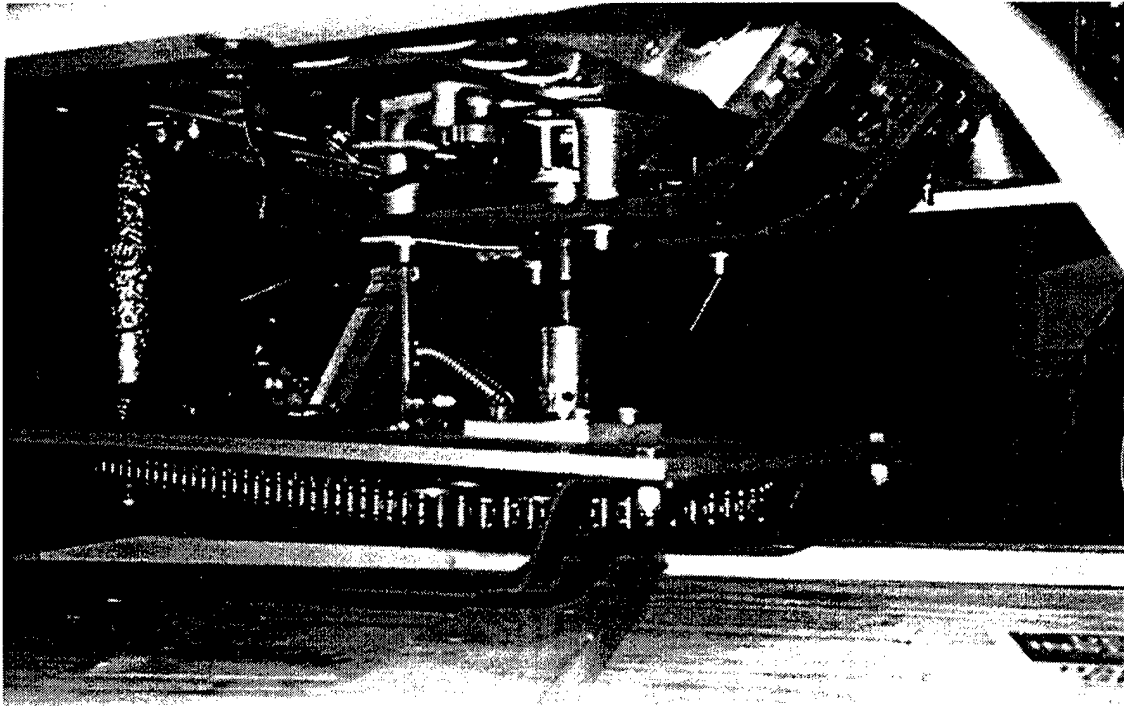

Figure 14. Starter Coupled to Engine

starter assembly to the landing gear skids when the starter is disengaged from the engine to ease in the pin release.

The electrical configuration consists of two 30 foot lengths of 4 gage DC wire attached to the starter motor. This distance puts the operator well outside of the 5 foot rotor radius and allows operation from outside the test area behind Building 230 at NPS. The leads are connected to the starter for the desired direction of rotation. At the operator's end, the leads are connected to a 12 volt car battery directly or through a solenoid. A momentary contact switch can be connected or direct momentary connection of the leads to the battery will start the engine.

3. Starter Operation

Engine start is accomplished in the following manner. The starter is set into position with all pins in place. The electrical connections are checked for proper hook-up and security. Once the area is clear and it is determined that it is safe to start the engine, the momentary contact switch is thrown and the starter engages the engine. Once the engine has fired the small diameter cable is pulled to disengage the starter from the engine via the spring loaded latch. Once the starter has dropped away another cable is pulled to release the pins on the main landing gear struts. Once the starter assembly is disconnected from the aircraft it is towed clear of the helicopter's operations area.

B. ENGINE COOLING SYSTEM

The engine cooling system was totally redesigned and modifications were made several engine components to accommodate the new system. Each deficiency listed in the engine cooling system deficiencies chapter was addressed and corrected resulting in a properly designed cooling system for the WAEL 342 engine's internal use.

1. Design Considerations

In order to effectively cool the engine cylinders it was necessary to remove as many obstructions to the cooling air flow as possible. The interior of the engine compartment is approximately 2.5 cubic feet. The engine and drive train occupies approximately forty percent of this space. The objective was to maintain an unobstructed flow of air through the engine compartment and supply cooling air from outside of the fuselage without inadvertent preheating as found in the previous design. The amount of cooling air to pass through the

engine compartment was based on the observations of the induced flow while the engine was on the test stand.

The need to know the maximum engine cylinder temperatures that the *Hummingbird* could encounter drove the size and therefore the configuration of the cooling fan that was to be installed. The cylinder head temperatures with the enlarged cylinder heads once installed was the ultimate driving force behind the cooling system design. Once again a simple design was desired in order to increase reliability, simplify maintainability and minimize cost and center of gravity shifts.

2. Cooling System Design Implementation

a. Cylinder Heads

As previously stated, the standard cylinder heads which was originally installed on the engine was replaced with the larger cylinder heads and are shown in comparison with each other in Figure 15. The effects of the improved heat dissipation through the significant increase in surface area have already been discussed. The larger heads required a standard size spark plug rather than the short plug used in the standard head. The engine manual called for a Bosch W6 BC spark plug with a 12.7 mm reach. An equivalent substitute plug, Splitfire SF 412C, was used due to the unavailability of the Bosch plug. The Splitfire plug has a smooth ceramic insulator where as other spark plugs have ridged ones. The smoothness caused the spark plug cap to slide off and disconnect during engine operation. To remedy this problem, retaining clips were installed to prevent the caps from working loose.

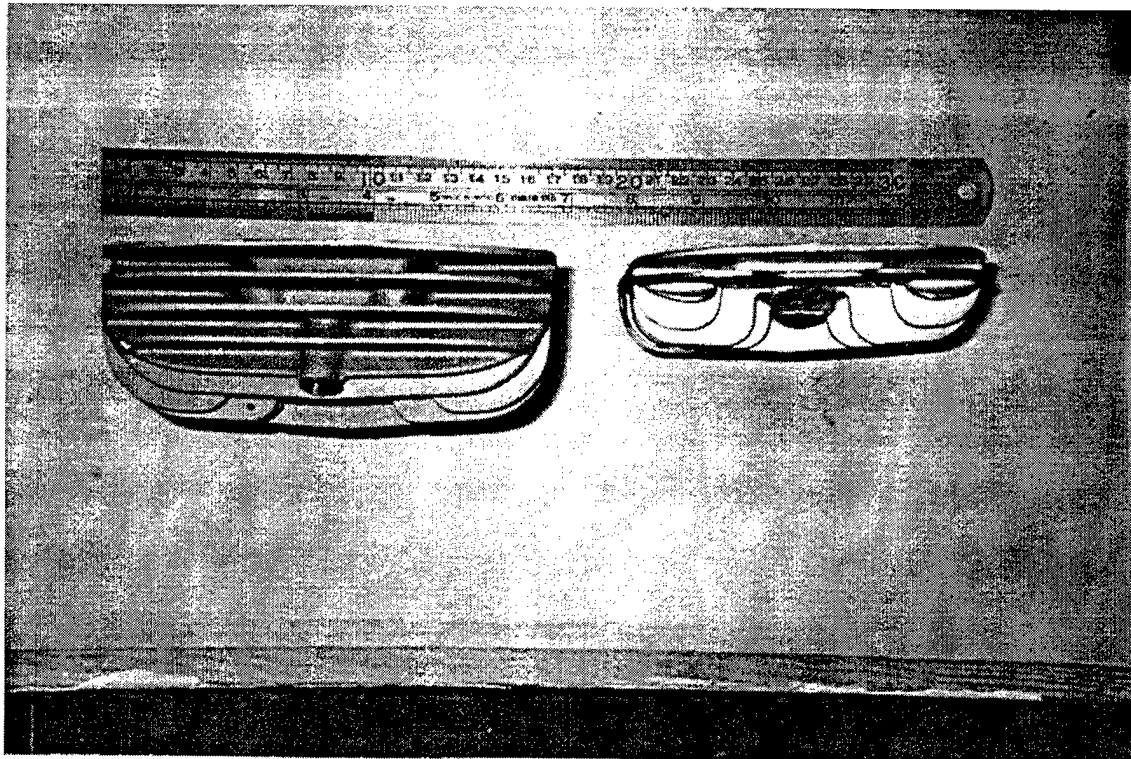
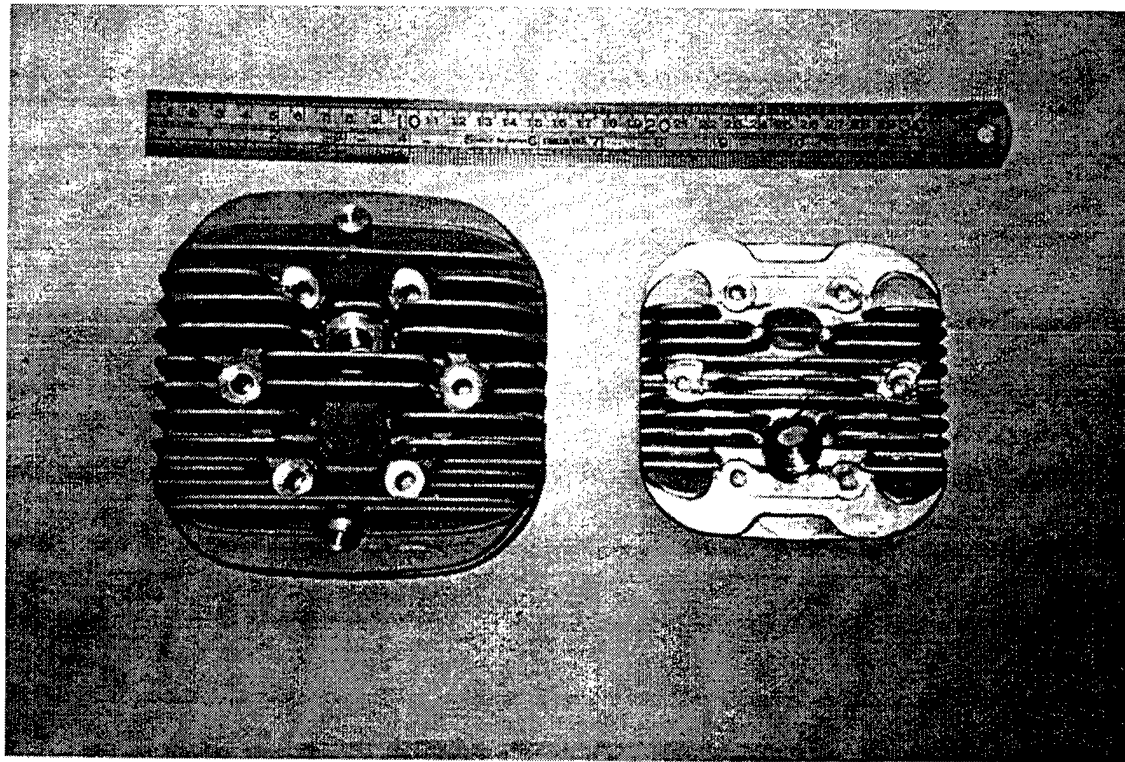

Figure 15. Size Comparison of Cylinder Heads.

(1) Upper Engine Mount. As the engine required some minor modification on the test stand, the *Hummingbird* required some airframe modification to accommodate the new enlarged cylinder heads. The four engine mounting points on the bottom of the airframe remained unchanged; however, the upper engine mounting bracket that was installed as a part of LT Greg Fick's [ref. 3] modifications shown in Figure 16 had to be moved aft by at least 1.04 inches due to the difference in the cylinder head thicknesses. The two side stiffening plates were moved aft to provide the necessary airframe support for the bracket's new position.

The bracket modification led to another problem. The upper engine mount braced the engine through two of the six 6 mm cylinder head bolts. The existing cylinder head bolt was not long enough to provide support for the cylinder head and also pass through the upper engine mount. Attempts to find longer bolts and 6mm threaded rod failed as no local supplier carried the longer bolts or metric size threaded rod. As a result, two adapters which acted as a cylinder head bolt, spacer and upper engine mount attachment point were designed to custom fit this application. Figure 17 shows this piece. The cylinder head bolt segment is 6 mm in diameter and includes the correct cylinder head bolt thread length. The spacer was designed to provide a gap between the cylinder head and upper mount brace so there will be no damage inflicted on the cylinder head heat fins while the both the engine and airframe vibrate. The remainder consists of the mounting bracket threads which are also 6 mm in diameter.

(2) Adapter Installation. To install the adapter the cylinder head bolt portion is first screwed in to place. To accomplish this two nuts must be locked

UPPER REAR ENGINE SUPPORT BRACKET

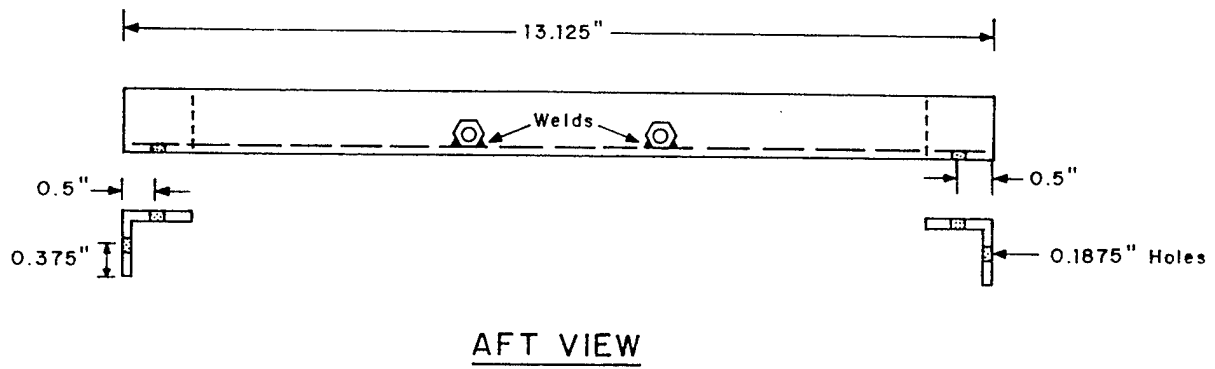
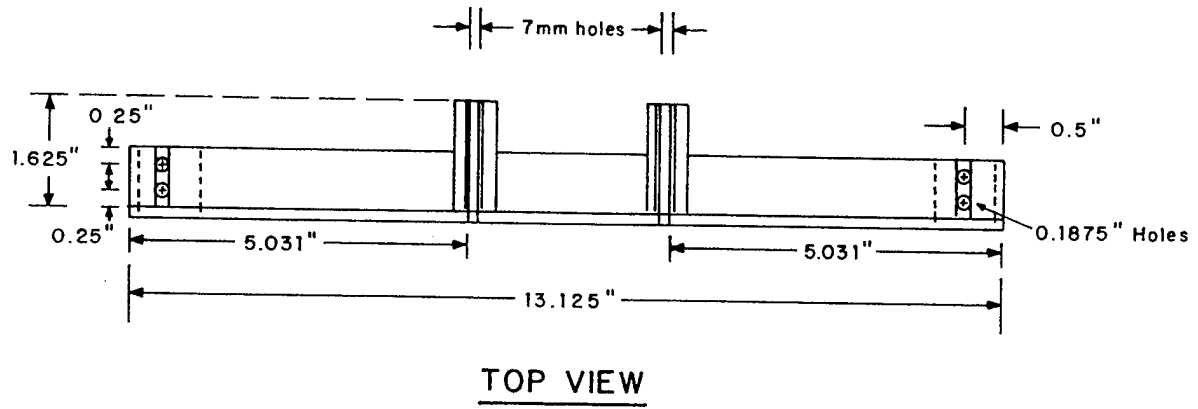

Figure 16. Upper Engine Mount

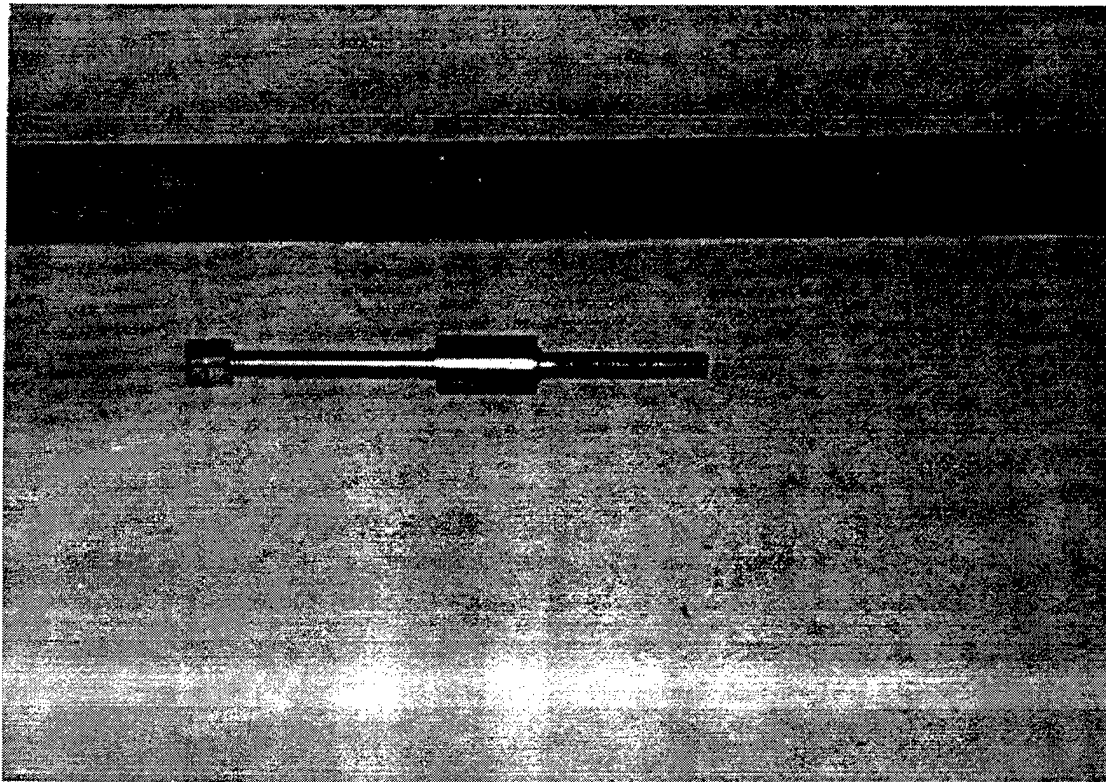

Figure 17. Spacer Bolt

against each other on the mounting bracket end and then the whole piece torqued to the cylinder head bolt torque specification. The two nuts are then removed and the mounting bracket is then slid over the free end. The mounting bracket is then secured by a two lock washers and nuts.

b. Component Removal

Several original components were removed in order to improve cooling air flow and/or to make room for design improvements. As previously mentioned the starter was removed as a weight saving measure. Removing this equipment also freed room for the

cooling air to flow more efficiently. The fiberglass cowling that previously directed the airflow over the cylinders and the vane-axial impeller was removed to accommodate a new air moving system and to further reduce the obstructions to the cooling air flow. Finally the original exhaust manifold and exhaust pipe were removed and replaced with two aluminum tube exhaust pipes that exhaust below the fuselage eliminating the undesirable heat source inside the fuselage.

c. Cooling System

After considering many options of cooling fans, configurations and suggestions from industry, a simple and reliable design was implemented. The cooling air velocity through the engine compartment was observed during the engine tests and a system to move air through at this speed was introduced. Two air-conditioning condenser fans rated at 500 cfm at 3000 rpm were purchased for less than \$6.00 and mounted to ventilate the new 1.3 cubic foot engine compartment. One fan was modified to fit on the tail rotor drive take-off shaft off the main transmission which rotates at 40 percent of the engine rpm or 1200 to 2800 rpm. The other fan was mounted to the rear wall of the engine compartment. As shown in Figure 20, the lower fan is driven by a belt drive configuration and rotates at the same rpm as the tail rotor drive shaft. The tail rotor shaft mounted fan provides cooling air primarily to the forward cylinder while the belt driven fan provides ventilation to the aft cylinder.

Information on this fan was unavailable. Measurement of the cooling fan air flow at 1500 rpm (approximate fan rpm at engine idle) showed approximately 345 cfm. Assuming a linear increase in air flow with increasing rpm as seen in several other fan

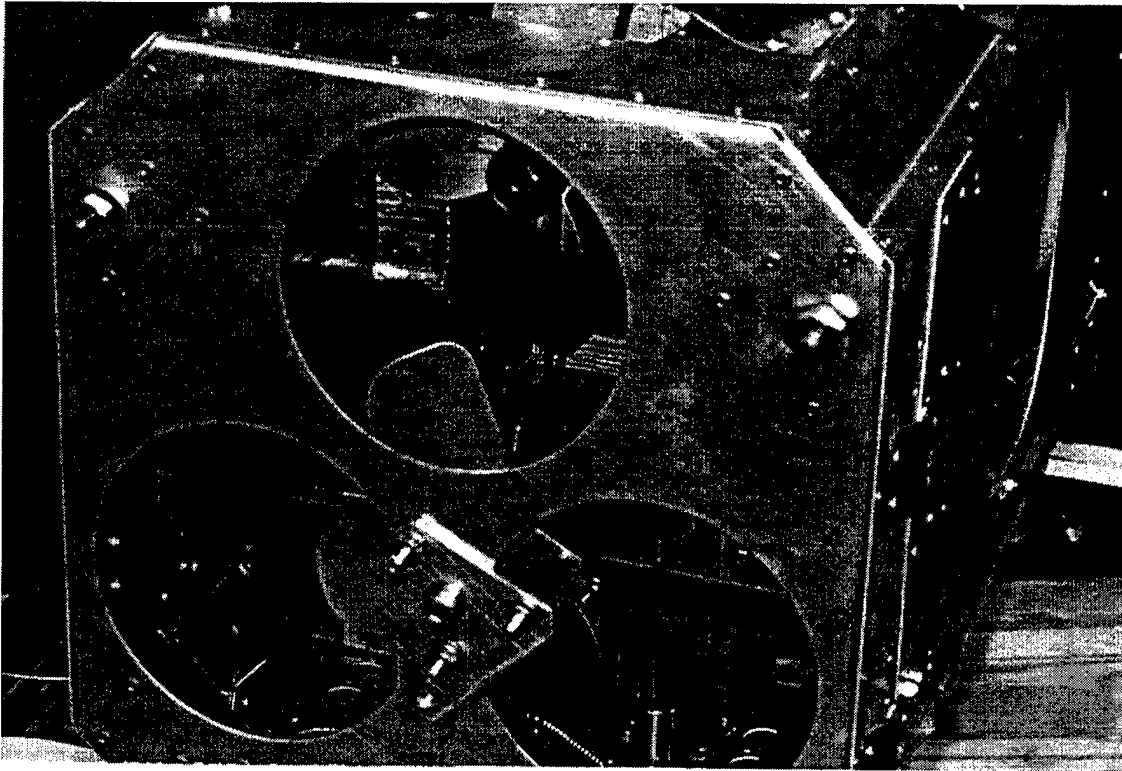

Figure 18. Cooling Fan and Drive Configuration

performance charts, the air flow at 2800 rpm is estimated at 480 cfm. Thus the two fans together produce 960 cfm at 7000 engine rpm through the engine compartment which exceeds the air flow pattern seen on the engine test stand.

The engine compartment was partitioned to keep the cooling air close to outside ambient temperature and direct the airflow to the critical engine areas. Thin sheet metal was installed to form fore to aft bulkheads on the left and right sides of the engine. Another partition was placed between the two longitudinal bulkheads to direct most of air from the belt driven fan over the aft cylinder. This partitioning reduces the space to be ventilated and directs the flow of air from the exterior of the fuselage, through the engine

compartment and out the bottom of the aircraft. Cooling air enters primarily through the two ports on the left and right sides of the compartment in forward flight to the fan inlets without interfering with the cooling air flow inside the partition.

LT Greg Fick [ref. 3] recommended in his thesis that the WAEL 342 engine be down rated from 25 hp to 18 hp which leaves ample power available for the fan drive system. The power required to operate the installed fans is estimated to be a small fraction of the 7 hp rated excess power.

C. DRIVE TRAIN

1. Design Considerations

The foretold and observed torque fluctuations of the engine were measured at a maximum of 10 ft-lb. Ideally the location in which to dampen the shock would be at the point of the maximum moment which in this case is the main rotor shaft. However, there is no room for any addition to this space due to the main rotor control rods and other connections. Balancing available space and shock reduction requirements placed the shock absorber design location at the intermediate shaft where the transmission picks up the engine drive. At this point the mechanical advantage is 3.2:1 putting the torque impulses at ± 32 ft-lbs. A shock absorber must be able to withstand and dampen this shock moment in addition to a maximum constant driving torque of 77 ft-lbs (24 ft-lbs from engine) at the intermediate shaft.

2. Shock Absorber Design

The intermediate shaft on the transmission shown in Figure 19 was selected as the location for the shock absorber assembly. The shock absorber itself is a Metalastik®

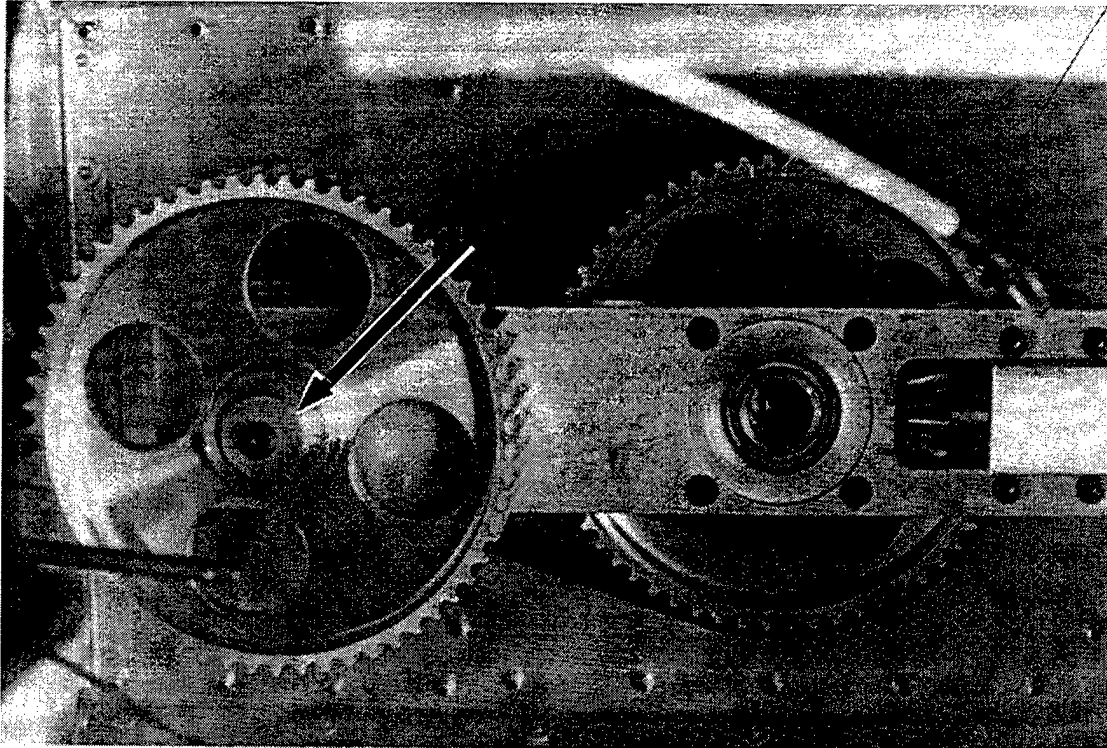

Figure 19. Intermediate Shaft of the Main Transmission

Rotoflex® coupling. It consists of a hexagon of rubber with six metal inserts bonded into position. It also contains metal interleaves bonded into the rubber for increased torque capacity when required. The coupling must be able to withstand a 76.8 ft-lb sustained load plus a 32 ft-lb impulse load totaling a maximum load of 108.8 ft-lbs. The 76.8 ft-lb moment was obtained by using the maximum torque rating of 24 ft-lbs and multiplied by 3.2 for the load at the intermediate shaft. . A coupling closest to this specification was ordered. This size coupling gives a safety margin of 1.33 computed for rated maximum torque to estimated

torque applied and is the largest size that will fit in the design location.

In the unmodified configuration the drive gear seen in Figure 19 is keyed to the intermediate shaft. In the modified configuration the gear is free to rotate about the shaft on a needle bearing. Mounted to the bottom of the gear's web by four bolts is the top plate of the shock absorber. This 0.375 inch thick and 4.5 inch diameter plate connects to the coupling with three of the six bolts and is also free to rotate about the shaft. The other three bolts connect the bottom plate of the shock absorber assembly. This plate is also 0.375 inch and 4.5 inch diameter and is keyed to the shaft and allows a shock dampened driving moment to pass through the rest of the drive train. A 0.125 inch thick spacer ring is mounted between the top plate and gear web to provide space for the bolt heads and washers mounting the two plates to the coupling. The design dimensions of the plates were obtained by strength of materials methods using the expected loads and applying a 1.5 safety factor.

The current intermediate shaft had to be lengthened to accommodate the extra components. The original shaft was 3.5 inches and was redesigned as a 6 inch shaft. A snap ring on the bottom of the shaft keeps the components in place. Two key slots in the shaft provide a mounting point for the bottom plate.

Due to unforeseen delays the shock absorber was unable to be installed. The installation calls for the upper plate and spacer ring to be mounted directly to the gear's web by four small bolts. A needle bearing is to be pressed into the inside of the drive gear allowing it to move freely about the shaft. The Rotoflex® coupling is then bolted to the upper plate and the lower plate bolted to the coupling. After the shaft keys and snap ring is in place, the assembly is then placed into the transmission. The Figure 20 shows the

unfinished components of the shock absorber system in the position they are to be mounted. The drawings in appendix D show the final form of the upper and lower plates, spacer ring and modified drive shaft.

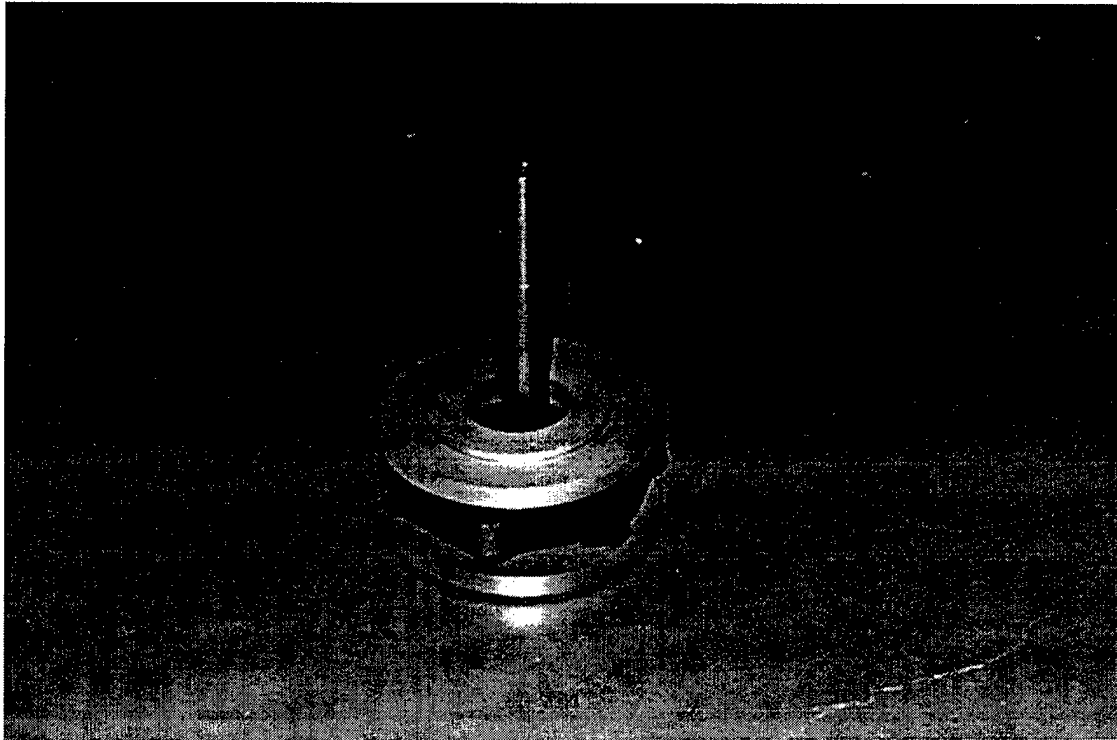

Figure 20. Layout of Shock Absorber Components

VI. GROUND TESTING

Initial ground tests of the *Hummingbird* were conducted to confirm the effectiveness of the design modifications. The tests were run in the fenced helicopter test area just behind building 230 at the NPS golf course. The *Hummingbird* was assembled without the forward fiberglass and tied to the ground with straps hooked to pad-eyes. The starter was put into position on the aircraft and the starter cables and electrical wires were connected and placed outside the fenced in area. A momentary hard connection to the battery was used to operate the starter.

Several attempts were made at starting the engine. The starter was determined as having enough rotational speed but the engine did not fire. Engine start was attempted seven times in two separate tests. Trouble shooting the systems led to the following possible problem areas.

First, the engine had not been started for four weeks prior to this test. Slow starting characteristics were noticed when long periods between engine tests existed in the engine test phase. In an effort to obtain ignition the throttle was opened fully and closed several times possibly flooding the engine. Flooding was confirmed by a strong gasoline smell from the exhaust pipes upon initial inspection of the RPH.

A possible inadvertent grounding of the magneto was another hypothesis and subsequently investigated. Prior to the test the UAV technician had difficulty with the aircrafts radio operated engine "kill" switch. However, the investigation showed proper electrical connection and continuity.

Finally, the strongest theory resulted from the above investigation. When removing the rear cylinder spark plug cap it was noticed that it was easier to remove than the forward one. This could indicate that the rear spark plug was not electrically connected causing the problem. The spark plug caps had not been inspected for security since the engine's installation approximately two weeks prior to the ground tests.

Along with the above problem the starter had suffered minor damage. The head of the hex-ball drive snapped off twice during the engine start attempts. The design feature of structural failure location convenience was proven by this. During the repair of the hex-ball, minor damage to the insert of the 7 inch sprocket was discovered. The insert was peeked where the clutch mechanism engaged. The shallow depth deformations were found around its entire circumference. The design dimensions and material of the insert was copied exactly from the *hummingbird's* original starter with the only difference being a straight bore to fit the 0.75 inch starter motor shaft where the original design incorporated a tapered bore. The aircraft mounted starter insert showed no evidence of this damage.

The most probable cause for the starter damage and engine starting trouble is thought to be the following. Prior to the first wrench head failure a popping noise indicative of engine ignition was heard; however, ignition was not sustained. Disconnection of one spark plug could cause this. The sudden unloading and loading of the starter caused by the firing of one cylinder would cause the peeing and wrench head failure. Necessary corrections are currently underway to remedy the starter damage and spark plug cap problem. Further ground testing will be an area of future study.

VII. CONCLUSIONS AND RECOMMENDATIONS

A. CONCLUSIONS

The critical shortcomings of the *Hummingbird's* power plant and drive train have been overcome through careful redesigning of the affected systems. While the power plant still possesses certain undesirable characteristics such as excess noise and vibration levels, the major design weaknesses of the discussed systems have been rectified in through design and experimentation. *Hummingbird* is now a more reliable platform ready for further ground testing and RPH research.

An extended reference list of personnel and information was developed in the background investigation of the WAEL 342 engine. Companies, points of contact and other information that will aid throughout the life of the *Hummingbird* have been documented.

The WAEL 342 engine was successfully tested and broken in with approximately 3.4 hours of accumulated operating time. Proper high and low speed needle jet setting were made to give the engine the smoothest operation and lowest possible cylinder head temperatures. The previous heavy and bulky exhaust manifold and pipe were replaced by lighter and more directly routed exhaust pipes preventing excess temperature build-up in the engine compartment that caused inefficient cooling in the original RPH design.

An improved starter for aircraft engine start and a hand-held starter for engine tests were designed, manufactured and shown effective in starting the WAEL 342. The use of the Prestolite MBJ-4407 provides unique flexibility in starting the engine in the *Hummingbird's* various configurations. The same starter motor used with the two starter designs starts the

WAEEL 342 on the engine test stand, in the *Hummingbird* mounted to an aircraft test stand and in the *Hummingbird* configured for flight operations.

An improved cooling system has been designed. The cooling air preheating problem of the previous design has been eliminated through the partitioning of the engine compartment and opening of the right side of the fiberglass body. Cooler engine temperatures attained during the engine tests by increasing the cylinder head size and properly setting the fuel mixtures reduced the cooling air volume required thus reduced the power requirements for the cooling system. Further ground testing is needed to confirm the efficiency of this system.

The torsional shock absorber will effectively reduce the torque fluctuations reported by Mr. Ken Beckman and observed during engine tests. Once installed the drive train components will experience reduced shock which will lengthen the life and increase the reliability.

The general goals in each of the system improvements have been successfully met. The reliability has been improved by the shock absorber and cooling system redesigns. The CG remained virtually unchanged as all the components removed and installed were at or very near the CG. Cost was kept to a minimum by incorporating a materiel acquisition hierarchy of recycling old *Hummingbird* parts, purchasing off-the-shelf items and finally using commercially produced items such as the larger cylinder heads and flexible coupling. The empty weight of *Hummingbird* was decreased by 5 pounds after all modifications. The removed items totaled 11 lbs and the installed items totaled 6 lbs. The empty weight of the RPH is now 119 lbs weighed on a TOLEDO industrial scale.

Finally and most importantly, user safety was significantly increased by the remote starting system. The system's components are kept on the ground at all times resulting in no interference with the rotor system and starts can be accomplished outside of the RPH test area for ground tests and at a safe 30 foot distance during flight operations. The Aeronautics and Astronautics Department is now in a position to continue with valuable RPH research.

B. RECOMMENDATIONS

The many design shortcomings of *Hummingbird* have been overcome to take the RPH from a target drone to a reliable research platform. However, there are still some ground and flight issues left to be resolved. Further improvements can also be made for specific fields of study such as Higher Harmonic Control (HHC) and NOTAR® research.

1. RPH Storage

The first six weeks of this research was spent identifying and assembling the parts of the *Hummingbird*. The RPH was haphazardly packed away and a box of small parts and other hardware was rolled over eliminating whatever order existed in the box. Valuable time was wasted. It is therefore recommended that the *Hummingbird* be completely assembled, with the exception of the main rotor blades and tail boom, prior to long term storage and that the RPH be stored in the helicopter research storage room in Halligan Hall. This will save valuable thesis time and better acquaint the student with the RPH.

2. UAV Lab Space

Whenever the *Hummingbird* is an active thesis project, a work bench should be provided at the UAV lab and not Building 230. While Building 230 provides a lot of room to work, necessary tools and the expertise of the UAV lab technician, Don Meeks, is

unavailable. Duplicating the required tools for an RPH lab in Building 230 would be very expensive and Mr. Meeks' presence is indispensable.

3. Complete Implementation of Torsional Shock Absorber

Unforeseen delays prevented the installation of this item. While the *Hummingbird* can be run and tested without it, the shock absorber should be installed as soon as possible to prolong the life of the drive train components.

4. Power Plant

The current air-cooled power plant (WAEL 342) has been improved for use in the RPH. However, other similar size RPH's use a liquid-cooled engine. An investigation should be made into suitable power plants, both liquid and air-cooled, to study the advantages and disadvantages of both. Ultimately, a selection of the best power plant should be considered and possibly implemented in the *Hummingbird*. As previously mentioned the power plant still vibrates excessively. A study into isolating the engine from the airframe is warranted. Reducing these vibrations would increase the life of the *Hummingbird* airframe and provide better flight vibration analysis in HHC research.

5. Configure *Hummingbird* for Forward Flight

Horizontal stabilizers are required for *Hummingbird* to achieve forward flight. Historical photos show similar RPH's with the stabilizers in place and attachment points are evident on the *Hummingbird*. A sample tailboom stabilizer is included in the *Hummingbird* parts inventory. Design and implementation of horizontal stabilizers are required to explore the entire flight regime.

6. Main Rotor Head Design

Currently the *Hummingbird* has a two-bladed main rotor head. In order to explore HHC, a three or four bladed rotor head is required. Instrumentation of this rotor head can also be implemented to research rotor blade and rotor head forces and moments when subjected to various flight maneuvers regimes.

7. NOTAR® Research

The design modifications made in this thesis were geared not to interfere with the NOTAR® tailboom designed and built by LT Robert King [ref. 4]. Investigation of configurations for counter-torque thrust should be commenced to further the NOTAR® portion of the RPH program. The NOTAR® tail is currently stored unprotected in Building 230. The tail boom and associated equipment should be moved and stored in the helicopter research storage room in Halligan Hall.

APPENDIX A: LIST OF SUPPLIERS

<u>Company</u>	<u>Items</u>	<u>City</u>	<u>Phone Number</u>
Allen's Starter Shop	Prestolite MBJ-4407	Seaside, Ca.	(408) 899-7689
Gerardi Bearing Co.	Chain, Sprocket, Bearings	Salinas, Ca.	(408) 422-5371
Grainger Inc.	Cooling Fans	Salinas, Ca.	(408) 757-0991
Grand Auto	Splitfire Spark Plugs	Seaside, Ca.	(408) 394-1472
Kragen Auto	Various Engine Support Equip.	Seaside, Ca.	(408) 396-7515
Lacey Automotive	3/8 in. Impact Socket	Seaside, Ca.	(408) 394-1418
Metalastik Inc.	Rotoflex Coupling	Schaumburg, Il.	(847) 519-1300
Orchard Supply	Hardware/Hex-ball	Sand City, Ca.	(408) 899-5144
Southwest Aerospace	WAEL 342 and its accessories	Tustin, Ca.	(714) 832-1333

APPENDIX B: POINTS OF CONTACT

<u>Point of Contact</u>	<u>Organization</u>	<u>Phone</u>	<u>Fax</u>
Ms. Debbie Smith	Target Technology Ltd.	011-44-1233-639762	011-44-1233-624883
Mr. Ian Matyear	Southwest Aerospace	(714) 832-1333	(714) 832-6090
Mr. Ken Beckman	N/A	(204) 339-0791	(204) 338-3702
Mr. Dave Davis	Chief Designer for Gorham's RPH's	Unknown	Unknown
Mr. John Gorham	Gorham Associates	(818) 889-2151	(818) 991-2740
Mr. Patrick O'Shea*	Russel Associates	(206) 455-3694	Unknown
Mr. Randy Messer	Prestolite Electric	(800) 346-8093	(800) 997-6202

* Mr. O'Shea represents several companies in the Bay area that may be helpful in future RPH research.

APPENDIX C: PRESTOLITE MBJ-4407 PERFORMANCE CHART AND ELECTRICAL SCHEMATICS

4-3-73

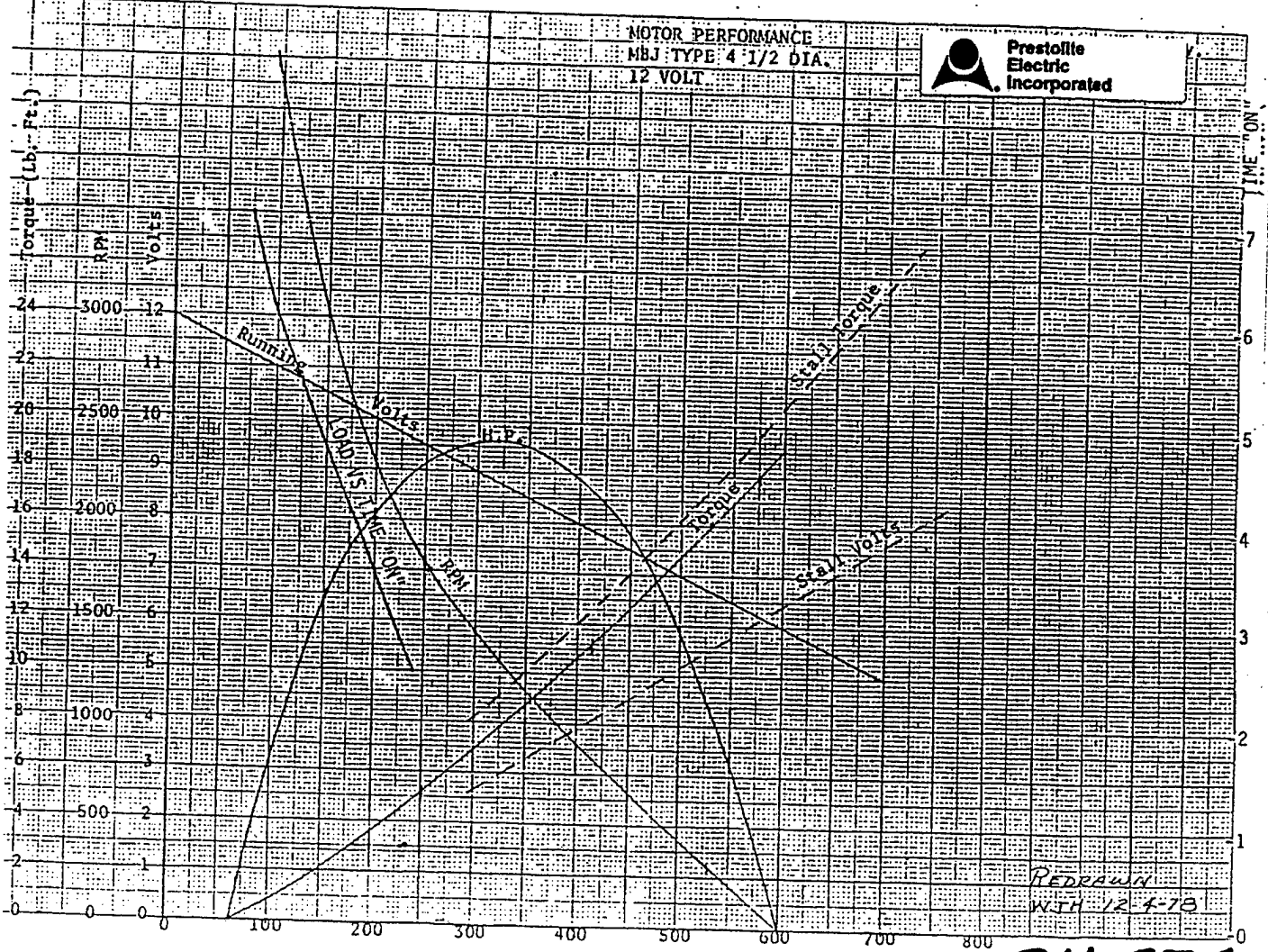

CU-674

TWO SOLENOID WIRING SCHEMATIC (4 LARGE TERM. - 2 SMALL TERM.)

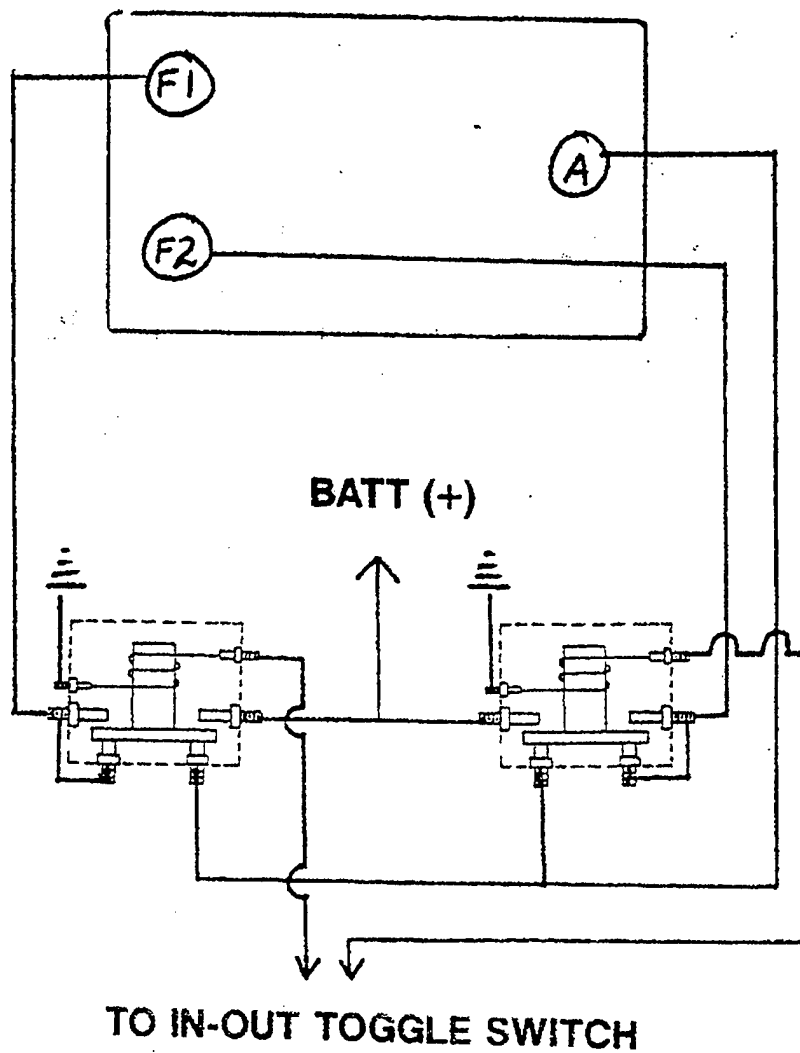

APPENDIX D: SPECIFICATIONS FOR DESIGNED PARTS

ENGINE SHAFT STARTER MOUNT

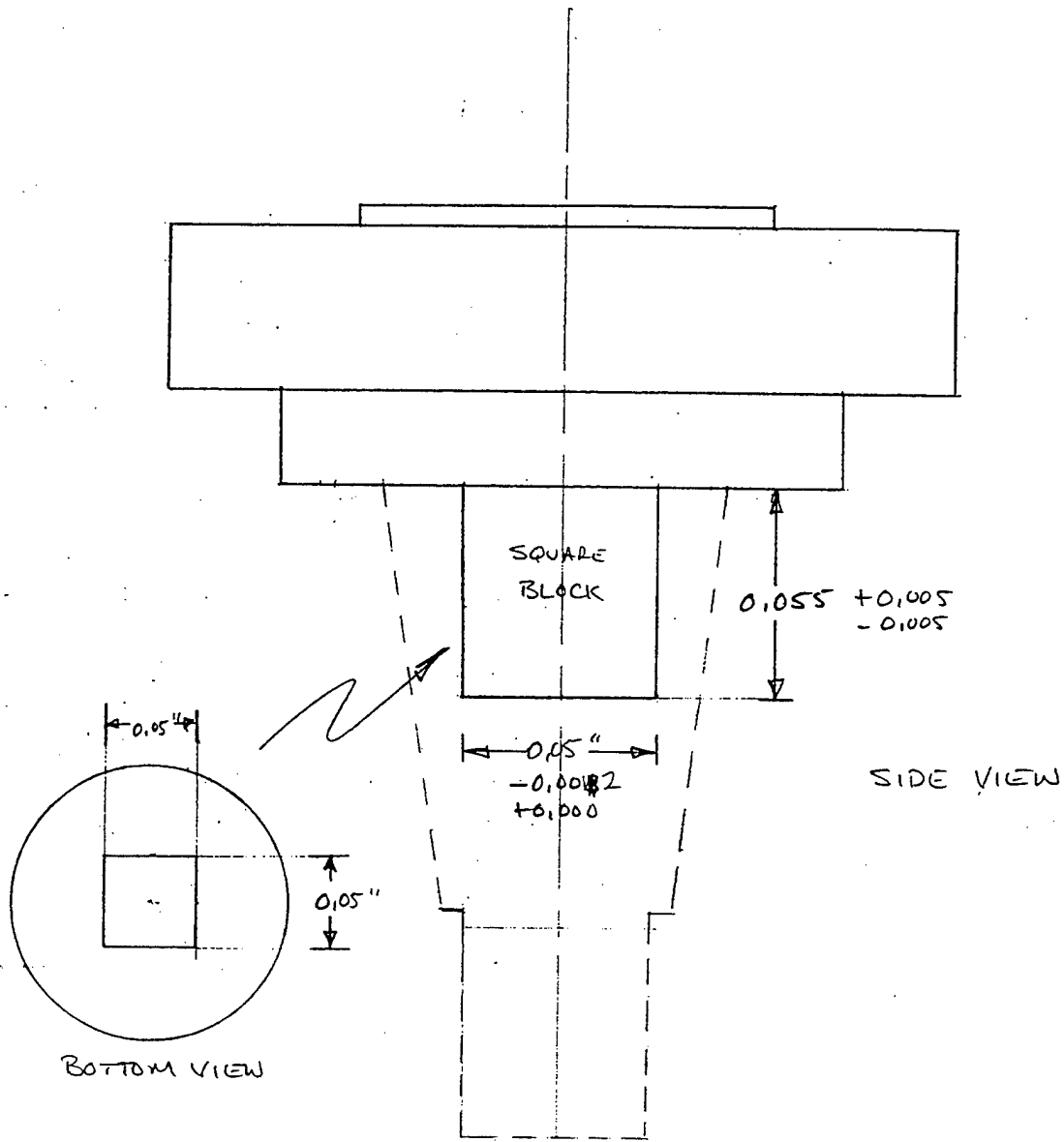

NEED EXISTING MATERIAL MILLEY
AWAY TO LEAVE 0.05×0.05 SQUARE

UPPER SHOCK ABSORBER MOUNT

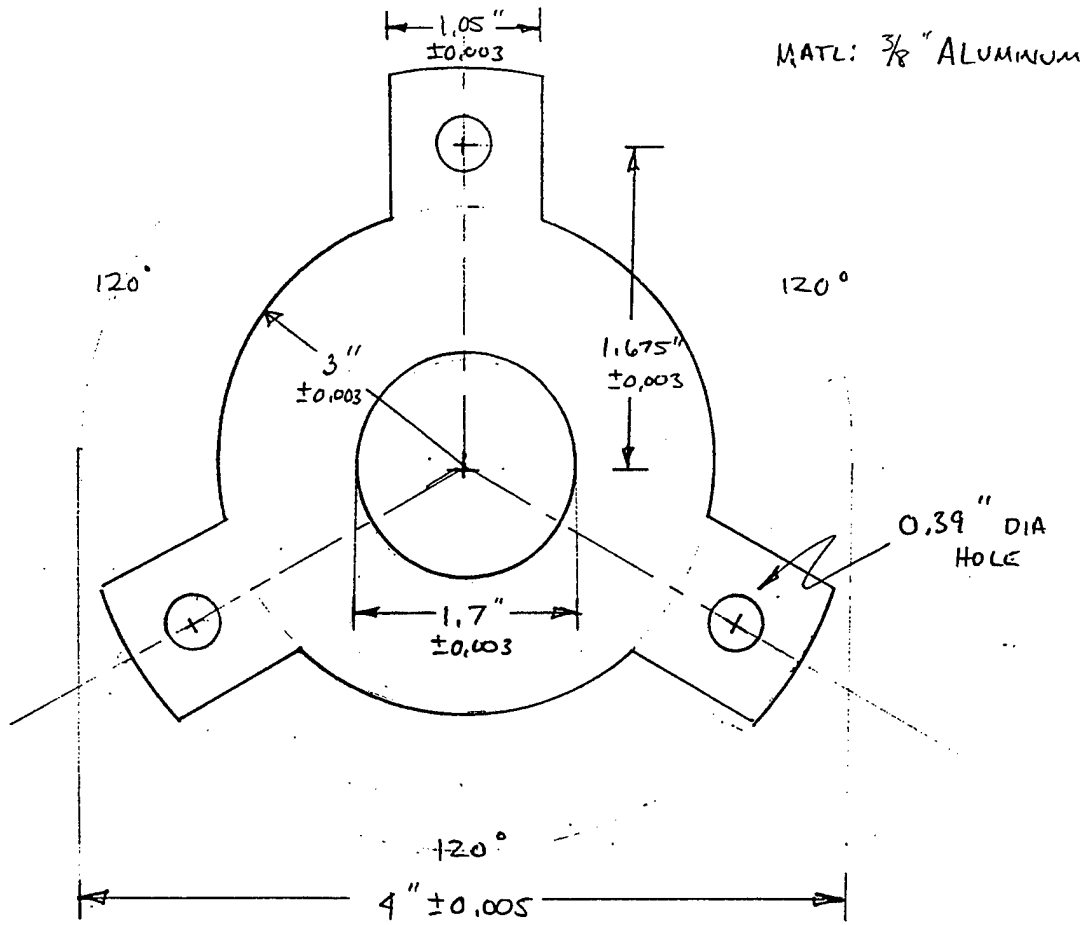

SPACER RING

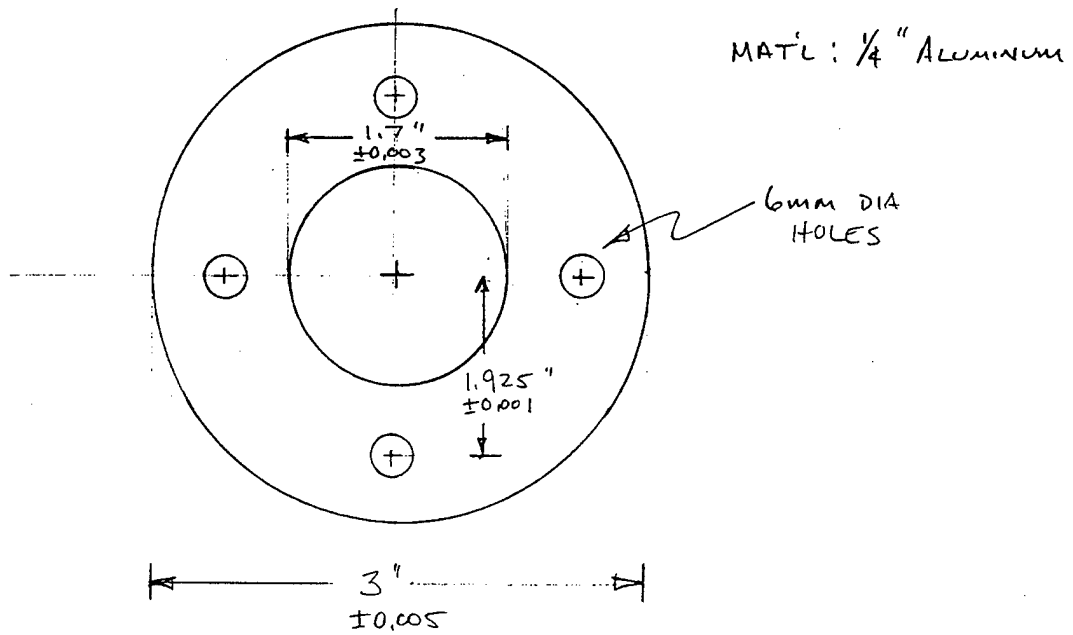

LOWER SHOCK ABSORBER MOUNT

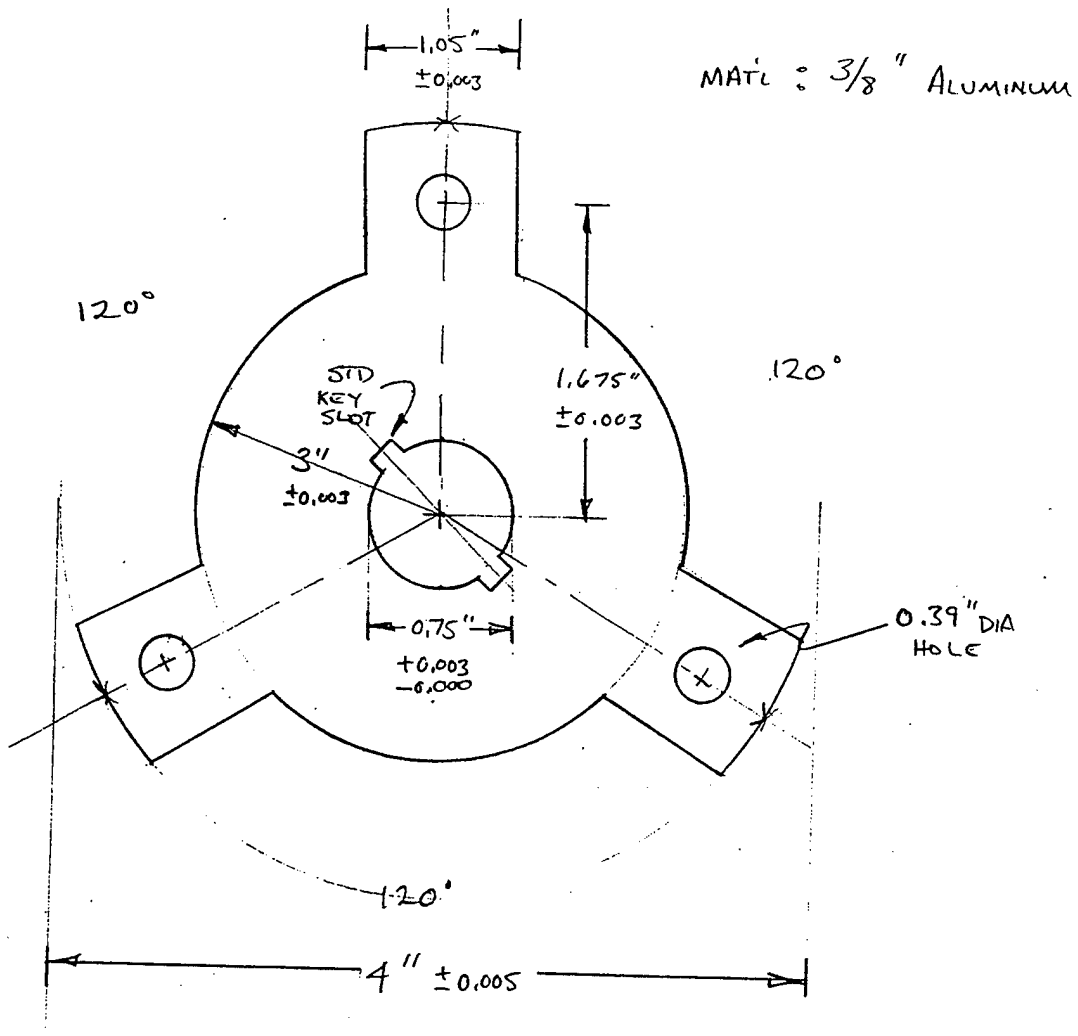

INTERMEDIATE SHAFT

MATL: STEEL

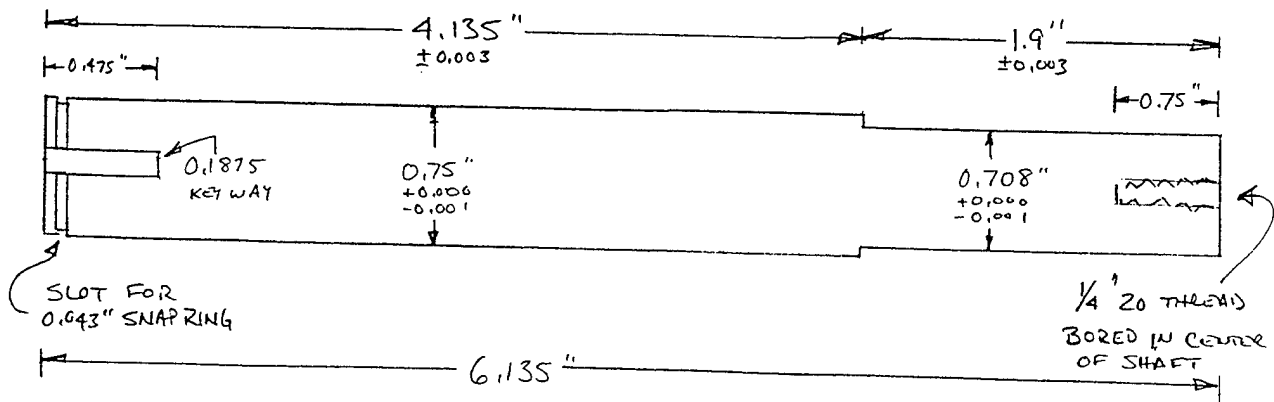

7" SPROCKET INSERT

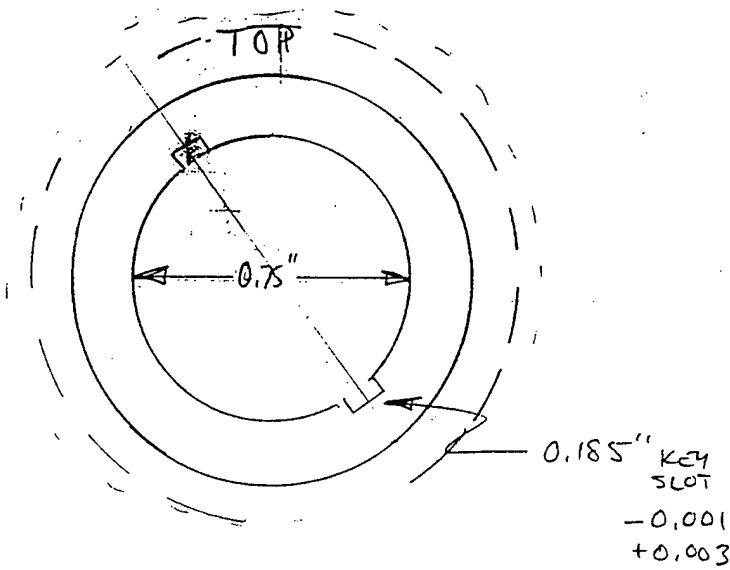
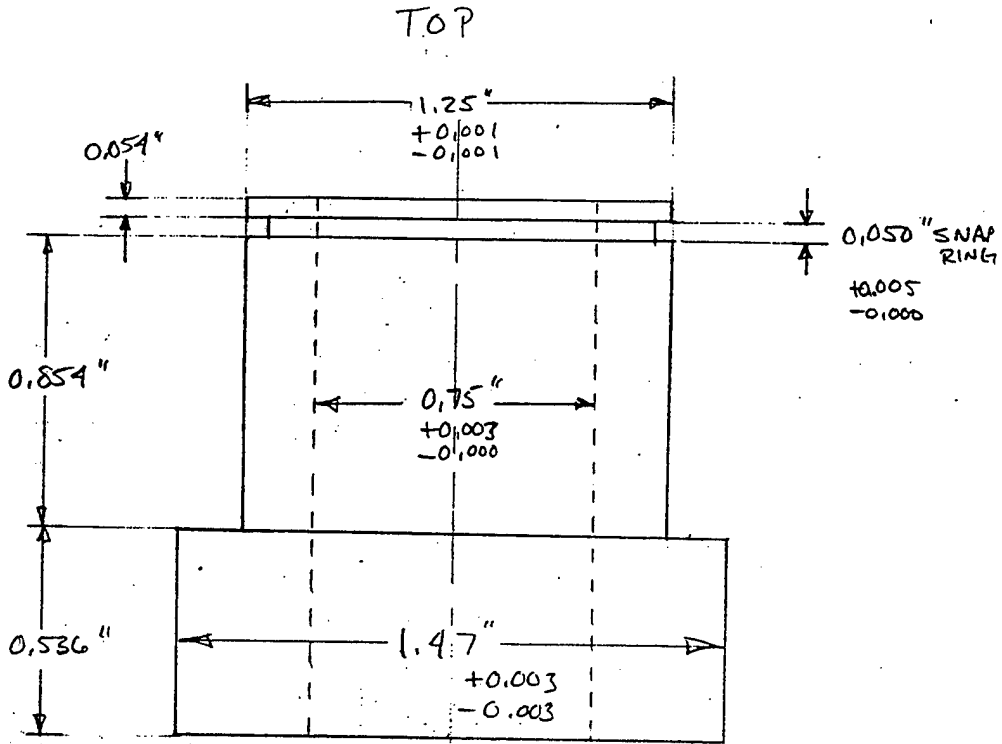

NEED ENTIRE PIECE MANUFACTURED

MATERIAL: HARDENED STEEL

SPACER BOLT

MAT'L : 1/2" STEEL
CYLINDRICAL ROD.

ALL TOLERANCES ± 0.005 "

6mm .1 THREAD

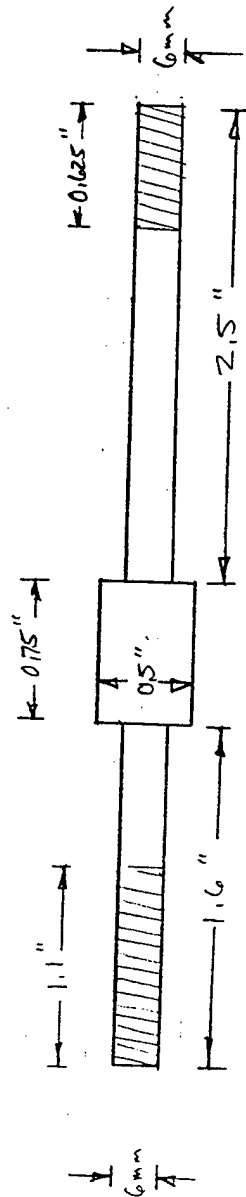

APPENDIX E: OPERATORS HANDBOOK FOR WAE 342 LIMITED ENGINE SERIES 2100D

2.0 SAFETY

Throughout this Manual are WARNING and CAUTION notes to warn of safety hazards to be avoided while installing, operating, maintaining or servicing the W.A.E. Limited 342 engine.

Operators should be familiar with the contents of this handbook with emphasis on these notes.

Make sure ignition switch is in OFF position and spark plugs leads are disconnected before working on any part of the engine or ancillary equipment.

Make no attempt to clean or adjust an engine while it is running. Special care should be taken when covers/guards are removed and covers/guards must always be refitted when work is completed.

Fire is a hazard; do not add fuel to tank while engine is running. Stop engine and allow a cooling period to prevent spilled fuel from igniting on contact with hot engine parts.

Do not operate the engine in a closed building.

It is extremely important to make sure that hands, feet and clothing are clear of all rotating and moving parts before starting the engine.

All rotating parts should be guarded where possible.

After servicing any part of the engine make sure all safety guards are refitted and secured.

Warning/safety signs are supplied with the W.A.E. Limited 342 engine and should be attached in a prominent position on the airframe and fuel tank as appropriate.

It is the responsibility of the operator to ensure that the equipment is not operated unless it is maintained in a safe condition.

DON'T operate in a closed building

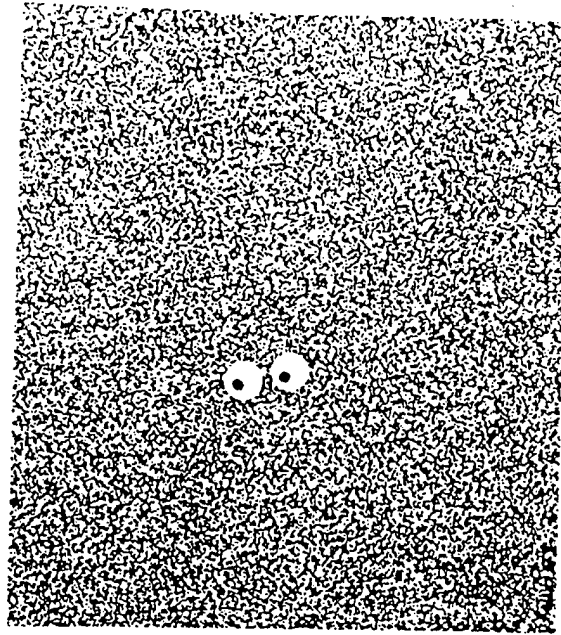

DON'T smoke while mixing fuel

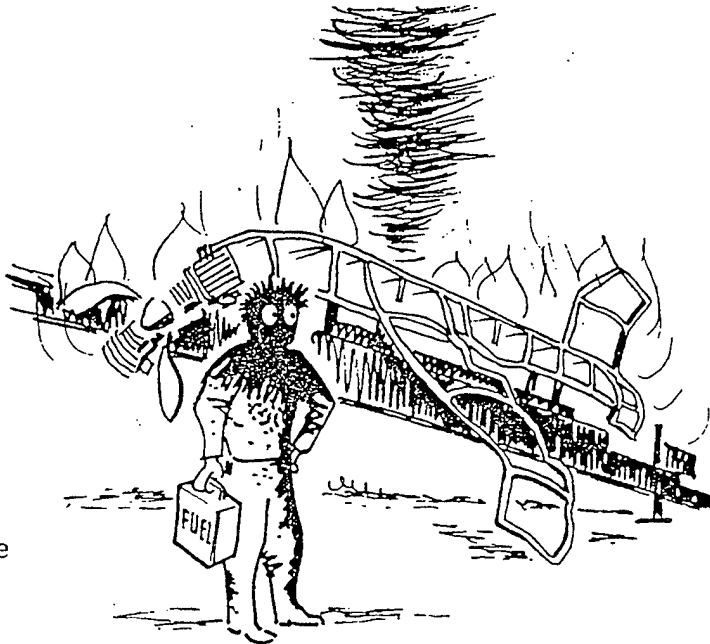

DON'T add fuel while engine is running

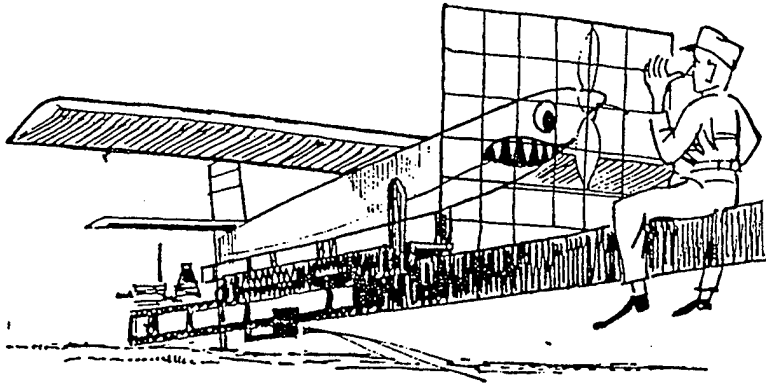

DO make sure all guards, if fitted, are replaced

DO make sure that all rotating parts are free from obstructions before starting engine.

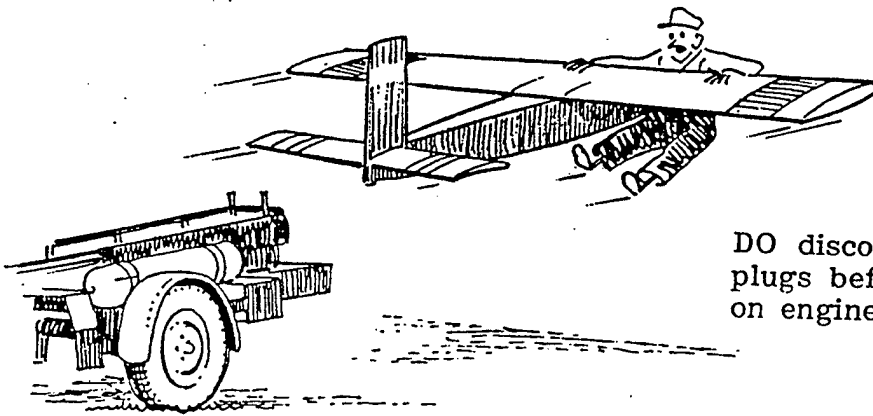
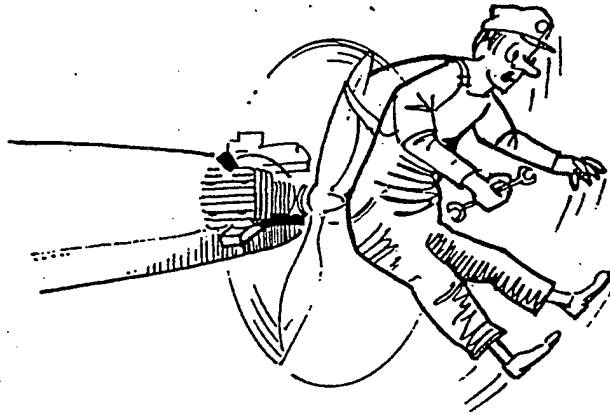

DO disconnect spark plugs before working on engine

DO make sure engine is properly secured to mounting bracket and airframe

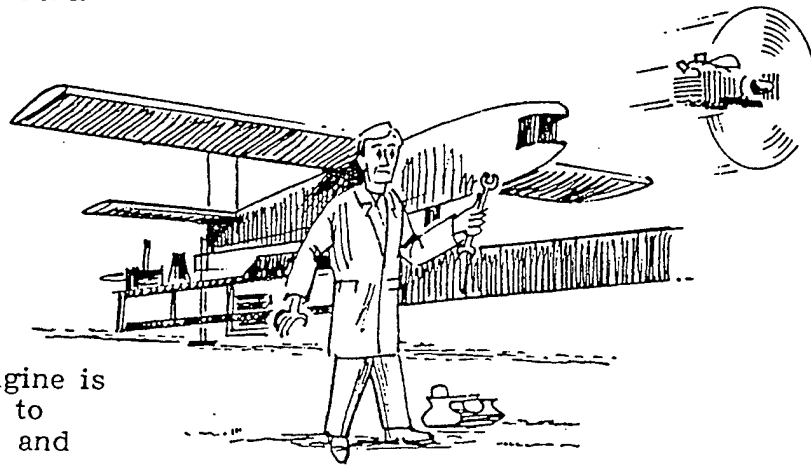

4.0 SPECIFICATION AND GENERAL DATA

The W.A.E. Limited 342 is an air-cooled, simultaneously-firing, horizontally - opposed, twin-cylinder engine of two-cycle operation.

CAUTION:

THE ENGINE IS AIRCOOLED AND MUST NOT BE RUN IN STATIC CONDITIONS UNLESS AN ADEQUATE COOLING AIRFLOW IS SUPPLIED. MAXIMUM CYLINDER HEAD TEMPERATURES MUST NOT BE EXCEEDED.

4.1 Specification

A three-piece forged-steel crankshaft, running on deep-groove ball bearings, is housed in a two-piece cast aluminium crankcase.

Mounted on the crankshaft are two forged-steel connecting rods, running on caged needle-roller bearings, pistons and flywheel assembly.

The cylinders are cast aluminium with vertically arranged cooling fins, to provide effective cooling from air passing around the engine. The bores are specially treated.

Ignition is provided by an engine-mounted, capacitor-discharge system, comprising an electronic module, ignition coils and spark plugs, and incorporating automatic-ignition advance.

The carburettor is mounted on the crankcase on a reed valve housing and manifold.

4.2 GENERAL DATA - SERIES 2100D ENGINE

Weight..... Ranges from 8.0 kg (17.5 lbs) to
10.4 kg (23 lbs) Depending on configuration
See appropriate Inst. Drawing

Dimensions..... (See Installation Drawing)

Bore..... 66 mm (2.59 in)

Stroke..... 50 mm (1.96 in)

Cubic capacity..... 342 cc (20.9 cu.in)

Compression ratio..... 7.1 (effective)

Compression pressure (cold)..... 930-965 kPa
(135-140 psig)

Power at rated speed..... 25 bhp (18,64 kw)
to SAEJ 607(a)

Maximum speed rated..... 7000 rev/min

Idle speed..... 1500-3000 rev/min
(Depending on propeller)

Maximum torque..... 32.50 Nm (24 lbf.ft.)
at 4000 rev/min

Carburettor..... Mikuni BN-34-30
Diaphragm Type

CAUTION:

CHANGES IN EXHAUST SYSTEMS
AND/OR AIR CLEANERS WILL
REQUIRE RE-ADJUSTMENT OF
CARBURETTOR NEEDLE JETS.

Fuel Consumption..... Approx. 5.6 litres/hour @
5250 rev/min
Against propeller load

Type of Fuel..... gasoline/oil 4% (25:1)

Gasoline..... RON 92 octane minimum

CAUTION:

**LEAD-FREE GASOLINE
MUST NOT BE USED**

Oil..... Finamix 2-stroke
or Silkolene Comp 2
Pre-mix

CAUTION;

**MULTIGRADE OIL
MUST NOT BE USED**

Fuel pipe..... 6,0 mm i.d. (0.25 in)
(not supplied) to SAE J30d

Airgap between electronic
module and flywheel..... 0,46 to 0,51 mm
(0.018 to 0.020 in)

Spark Plug

Standard Cylinder head..... Bosch WSR 6F (9.5 mm reach)

SPARK SF 412C ± 0.02

Large Cylinder head..... Bosch W6 BC (12.7 mm reach)

Spark Plug Gap

Bosch WSR 6F..... 0,50 to 0.56 mm
(0,020 to 0,022 in)

Bosch W6 BC..... 0,7 to 0,8 mm
(0.028 to 0.031 in)

Cylinder head temperature (maximum)..... 250 deg C
(Measured at spark plug gasket) (482 deg F)

Exhaust gas temperature (maximum)..... 550 deg C
(Measured 25-30 mm from exhaust flange) (1022 deg F)

Spark plug torque setting..... 29,80 Nm
(22 lbf.ft)

CAUTION:

SPARK PLUG GASKET MUST BE REMOVED
IF A CYLINDER HEAD TEMPERATURE
THERMOCOUPLE IS USED.

Cylinder head screws..... 12.2 Nm (108 lbf.in)
torque setting. NOTE: RE-TORQUE CYLINDER HEAD
SCREWS AFTER INITIAL 2 HOURS RUNNING.

Cylinder base screws..... 12.2 Nm (108 lbf.in)
torque setting

CAUTION:

TORQUE WRENCH MUST BY USED TO
ENSURE CORRECT TORQUE SETTING

NOTE: ALL TORQUE CHECKS MUST BE
CARRIED OUT WITH THE ENGINE COLD.

5.0 INSTALLATION

WARNING:

BEFORE OPERATING, ENGINE MUST BE SECURED TO MOUNTING BRACKET OR AIRFRAME. FAILURE TO SECURE ENGINE CORRECTLY MAY RESULT IN DAMAGE TO AIRFRAME AND/OR LOSS OF ENGINE AND INJURY TO OPERATOR.

CAUTION:

ALWAYS ENSURE IGNITION IS SWITCHED OFF (GROUNDED), WHEN ROTATING ENGINE CRANKSHAFT WITH SPARK PLUGS REMOVED FROM CYLINDERS, OTHERWISE DAMAGE TO IGNITION SYSTEM WILL OCCUR.

- 5.1 Remove all protective coverings.
- 5.2 Remove keeper-plate from ignition flywheel.
- 5.3 Fit recommended air inlet horn and/or air filter suitable for the installation. (See Installation Drawing).

WARNING:

THE MOUNTING BRACKET MUST BE OF A DESIGN THAT WILL NOT FAIL UNDER NORMAL RUNNING CONDITIONS.

- 5.4 Fit engine to engine mounting bracket on airframe (refer to Installation Drawing).

Base Mounting 4 x M8 screws with suitable fastener locking device, minimum thread engagement 15 mm. Torque screws to 14 Nm (124 lbf ins) maximum.

Rear Mounting 6 x M6 screws with suitable fastener locking device, minimum thread engagement 10 mm. Torque screws to 8 Nm (72 lbf ins) maximum.

- 5.5 Fit 73 mm stub exhaust pipes or installation exhaust system, using gaskets supplied (refer to Installation Drawing) and torque tighten bolts to 6 Nm (53 lbf ins) maximum.
- 5.6 Connect fuel line (customer supply) to carburettor fuel connector (FIGURE 5-1). Ensure a fuel filter 50 microns (0.002 in) is incorporated in fuel line.
- 5.7 Connect throttle cable (customer supply) to carburettor throttle lever (FIGURE 5-1).

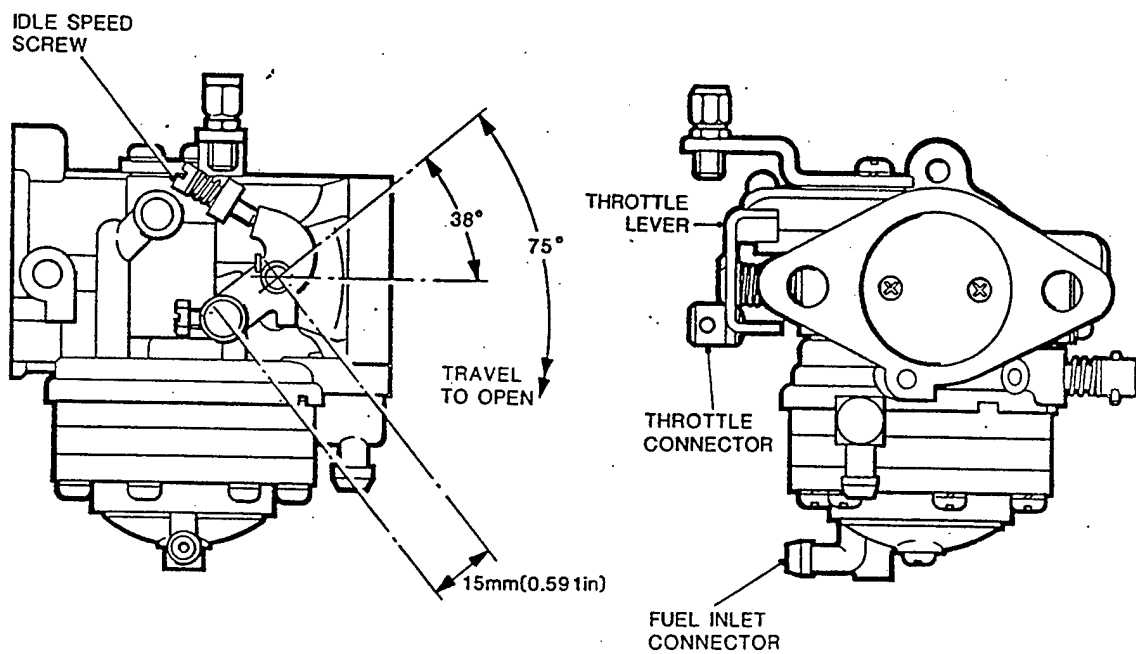

FIGURE 5-1 : CARBURETTOR

- 5.8 Connect ignition cut-out wire to ignition switch (customer supply) (reference FIGURE 5-2).
- 5.9 Remove protection caps from spark plug holes and rotate engine crankshaft 4 - 5 times to clear excess oil from the engine. Check and gap, new spark plugs and install. Torque to 29.80 Nm (22 lbf ft).

NOTE: Spark plug gap, see general data.

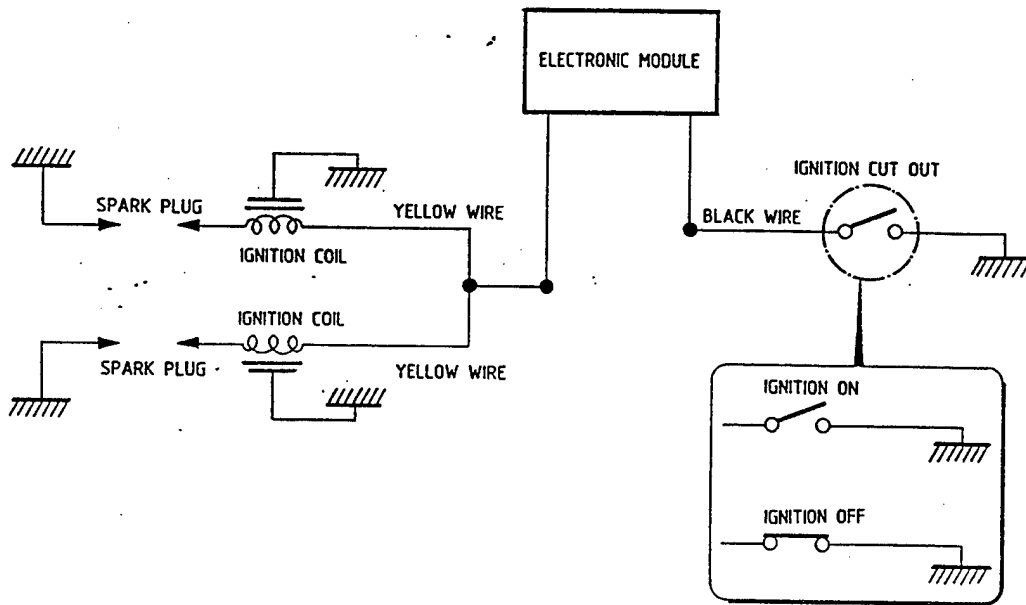

FIGURE 5-2 : IGNITION SYSTEM - CIRCUIT DIAGRAM

WARNING:

**MAKE SURE ALL ROTATING PARTS ARE
FREE OF OBSTRUCTIONS BEFORE
STARTING THE ENGINE**

- 5.10 Start engine and set carburettor to give an engine idle speed of 2400 rev/min or as required. (See adjustments and maintenance for setting of carburettor).

CAUTION:

**ENGINE MUST BE UNDER NORMAL
OPERATING LOAD (PROPELLER
INSTALLED) BEFORE ENGINE
IS STARTED.**

6.0 OPERATION

WARNING:

DO NOT FILL FUEL TANK TO MAXIMUM CAPACITY. COOL GASOLINE EXPANDS CONSIDERABLY, DUE TO HIGHER OUTSIDE TEMPERATURES, AND BUILDS UP PRESSURE IN FUEL TANK. THIS CAN CAUSE FUEL LEAKAGE AND A POTENTIAL FIRE HAZARD. ENSURE FUEL TANK IS PROPERLY VENTED.

6.1 Recommended Gasoline

Use only leaded automotive gasoline that has a minimum octane rating of 92 RON.

If recommended gasoline is not available, contact the engine manufacturer.

CAUTION:

DO NOT USE UNLEADED GASOLINE.

WARNING:

GASOLINE IS EXTREMELY FLAMMABLE AND HIGHLY EXPLOSIVE UNDER CERTAIN CONDITIONS. ALWAYS STOP ENGINE AND DO NOT SMOKE OR ALLOW NAKED FLAMES OR SPARK NEAR WHEN REFUELLING. ALWAYS MIX IN WELL-VENTILATED AREAS.

6.2 Recommended Lubricant

Use only (Petrofina) Finamix 2-stroke oil or Bel-Ray MC-1+. If recommended 2-stroke oil is not available, contact the engine manufacturer.

CAUTION:

DO NOT UNDER ANY CIRCUMSTANCES USE MULTIGRADE OILS.

6.3 Fuel Mixture

The correct fuel mixture is 1 part of oil to 25 parts of gasoline (4% oil mixture).

Metric Measure	U.S. Measure	Imperial Measure
160 cc oil to each 4 litres of gasoline	5 fluid oz oil to each 1 U.S. gallon of gasoline	6 fluid oz oil to each 1 Imp gallon of gasoline
USE AT 25:1 RATIO, AS SHOWN ABOVE		

IMPORTANT:

USING LESS THAN THE RECOMMENDED PROPORTION OF OIL MAY RESULT IN SERIOUS ENGINE DAMAGE FOR LACK OF SUFFICIENT LUBRICATION. USING MORE THAN THE RECOMMENDATIONS COULD CAUSE SPARK PLUG FOULING, ERRATIC CARBURATION, EXCESSIVE SMOKING AND FASTER-THAN-NORMAL CARBON ACCUMULATION.

CAUTION:

GASOLINE IS EXTREMELY FLAMMABLE AND HIGHLY EXPLOSIVE UNDER CERTAIN CONDITIONS. OBSERVE FIRE PREVENTION RULES, PARTICULARLY THE MATTER OF SMOKING. MIX FUEL OUTDOORS OR AT LEAST IN A WELL VENTILATED LOCATION.

Use only clean oil and gasoline containers as even a very small particle of dirt can cause carburation problems.

Mix fuel accurately in a remote tank. To ensure thorough mixing of oil and gasoline, fill container with gasoline to one quarter full, add oil and then add balance of gasoline. Mix thoroughly before using.

NOTE: Always use fresh gasoline.

6.4 Starting

WARNING:

MAKE SURE ALL ROTATING PARTS ARE FREE OF OBSTRUCTIONS BEFORE STARTING ENGINE.

CAUTION:

THE ENGINE IS AIRCOOLED AND MUST NOT BE RUN IN STATIC CONDITIONS UNLESS AN ADEQUATE COOLING AIR-FLOW IS SUPPLIED.

- 6.4.1 Check that spark plug leads are securely connected to spark plug terminals.
- 6.4.2 Turn on fuel supply.
- 6.4.3 Set decompressors by depressing caps situated on cylinder barrels (FIGURE 6-1).

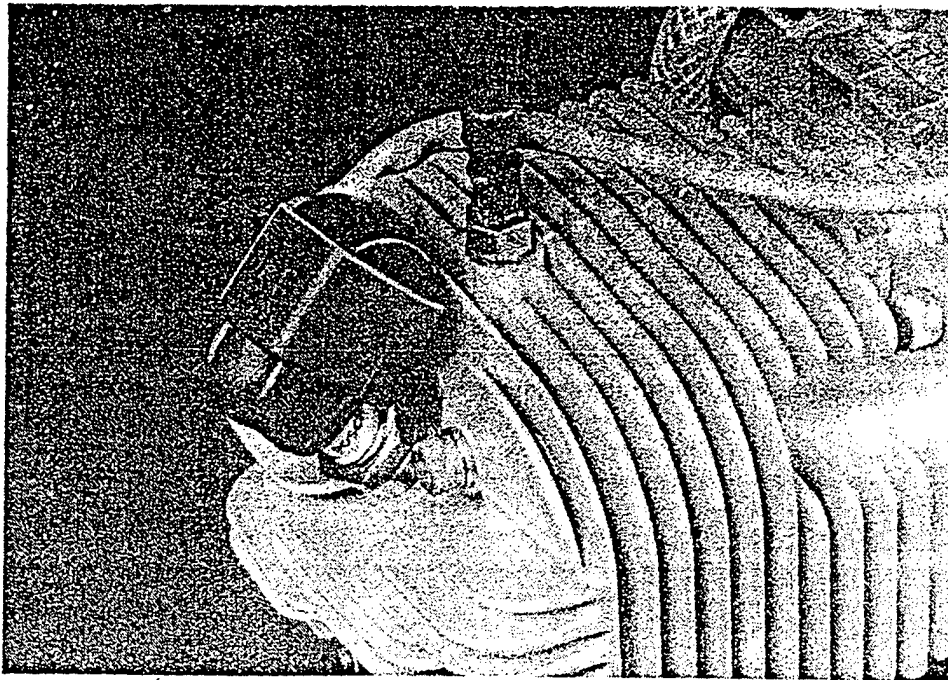

FIGURE 6-1

6.4.5 On a cold engine (first start), move throttle control to approximately half-open position.

NOTE: With the engine warm, it can be started at idle position.

6.4.6 Turn the ignition switch to ON position.

6.4.7 Crank engine until engine fires and continues to run.

NOTE: A minimum starting speed of 1,000 rev/min is required.

6.4.8 Move throttle control to 'idle' position.

NOTE: Decompressors must be depressed each time engine fires, but fails to start.

6.5 Stopping

6.5.1 Move throttle control to 'idle' position.

6.5.2 Turn ignition switch to OFF position.

WARNING:

DISCONNECT SPARK PLUG LEADS BEFORE WORKING ON ANY PART OF ENGINE OR ACCESSORIES.

6.6 Break-in (New engine)

CAUTION:

FOLLOW BREAK-IN PROCEDURE CAREFULLY.

During the first 60 minutes, operate the engine for short periods of time at varying speeds up to three-quarters-open throttle. Avoid operating at low and continuous speeds to prevent build-up of heat. After this period use the engine as required without exceeding the specified maximum temperatures.

NOTE: RE-TORQUE CYLINDER HEAD SCREWS AFTER INITIAL 2 HOURS RUNNING.

NOTE: During break-in 10cc of "Molyslip E" per 5 litres of gasoline may be used to improve lubrication and protect the engine. Continued use of Molyslip E in the quantities specified will not adversely affect the engine and may prolong its useful life.

7.0 INSPECTION AND SERVICE

Check the following items before each period of operation.

7.1 Fuel

Before starting the engine, be sure that there is an adequate amount of fuel in the tank. The fuel ratio must be 25:1 mixture of gasoline and oil.

CAUTION:

DO NOT FILL FUEL TANK COMPLETELY FULL. GASOLINE WILL EXPAND AS IT WARMS, CAUSING LEAKAGE AND A FIRE HAZARD IF THERE IS NOT ROOM FOR EXPANSION.

7.2 Fuel Line Connections

Check fuel line connections from fuel tank to engine for leaks. Make sure fuel line is firmly connected.

7.3 Spark Plugs

Keep spark plugs clean; a fouled plug can be the cause of serious engine problems. Make sure spark plug connections are tight.

Do not sand-blast, scrape or otherwise attempt to service spark plugs that are in a poor condition - best engine results are obtained with new spark plugs.

7.4 Cooling

Make sure baffles and cooling shrouds (if fitted) are in place and secure. Check that air intake openings are clean and unrestricted. Ensure cooling fins on the engine are clean and not damaged or broken.

WARNING:

DO NOT OPERATE ENGINE WITH DAMAGED OR BROKEN COOLING FINS.

The engine is air cooled and must not be run in static conditions unless an adequate cooling airflow is supplied to keep the cylinder head temperature within the specified limit (see general data).

WARNING:

**AFTER SERVICING, MAKE SURE ALL SAFETY
GUARDS ARE REPLACED AND SECURED.**

8.0 ADJUSTMENTS AND MAINTENANCE

WARNING:

MAKE SURE IGNITION SWITCH IS IN OFF POSITION AND SPARK PLUGS LEADS ARE DISCONNECTED BEFORE WORKING ON ANY PART OF THE ENGINE OR ANCILLARY EQUIPMENT.

8.1 Spark Plugs

Replace spark plugs every 25 running hours or as required.

Remove spark plugs and check condition; replace if carbon fouled or if porcelain is cracked. The colour of the spark plug is a good indication of operating conditions. Take corrective action if other than normal operation is indicated. Refer to spark condition chart below:

BLACK	TAN	WHITE
CARBON FOULING	NORMAL	OVERHEATING

When installing spark plug, set plug gap (see general data) and clean the spark plug seat in the cylinder head. Install plug and gasket and torque tighten to 29,80 Nm (22 lbf ft.).

8.2 Carburettor Adjustments

WARNING:

WHEN ADJUSTMENT IS MADE WITH ENGINE RUNNING, BE EXTREMELY CAREFUL NOT TO TOUCH MOVING PARTS AND HOT AREAS.

The tendency for the engine to "4 stroke" can be reduced by a slightly lean mixture. A low idle speed will impair engine acceleration or throttle response when the throttle is opened rapidly.

If rich, the "4 stroking" will be pronounced and the engine will accelerate quickly up to a point - after which the rpm will not increase. A good rule is to have the idle mixture slightly rich, in order to avoid the possibility of having the engine stop, and to allow better throttle response.

NOTE: All adjustments must be made with the air filter and/or inlet horn installed. If adjustments are made with the filter and/or inlet horn removed, the carburation will be incorrect when the filter and/or inlet horn is reinstalled.

Adjustment of the high-speed needle jet must be done while monitoring the spark plug gasket temperatures and the engine speed. The high-speed adjustment is made with a hot engine, once the idle adjustments have been satisfactorily completed.

The engine should be fully warmed up before any adjustment is made to the carburettor.

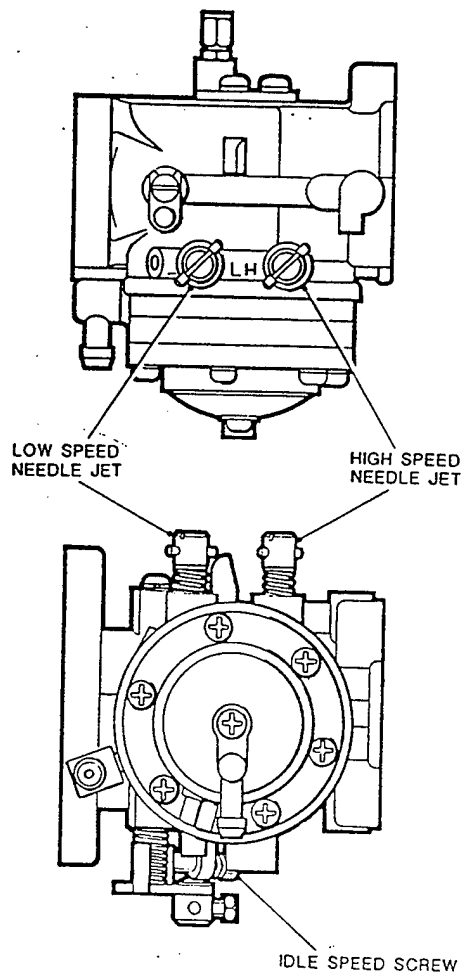

The initial carburettor "Hi" and "Lo" needle jets and the idle-stop screw are adjusted at the factory, if further adjustment is required due to installation and/or geographical location, then:

- Screw idle-speed screw in or out to obtain required idle speed.
- The low-speed needle jet should be adjusted to obtain a smooth idle.

The carburettor will require repeated re-adjustments between the idle-speed screw and the low-speed needle jet, until a smooth idle is obtained at the required idle speed.

NOTE: Clockwise adjustment of the adjusting screws decreases the amount of fuel/oil mixture delivered and vice-versa.

8.3 Factors that can affect carburation

In some instances, carburation which has been properly set up in particular conditions, can then be upset by certain factors, i.e.:

- change of fuel used
- change in atmospheric pressure
- change in air temperature
- change in exhaust systems.

If in any doubt, contact engine manufacturer.

- 8.3.1 Check initially to see how easy the engine responds to the throttle when opened smoothly and fully. A certain amount of sluggishness is an indication of a lean mixture and it is necessary to quickly open the high-speed screw until the engine begins to "4 stroke". Again, open the throttle smoothly until it is fully open, while watching the rpms obtained. Continue this evaluation by slightly 'leaning' the high-speed mixture each time the throttle response is checked and the rpms read. This is continued until the mixture needs to be richened in order to obtain the highest possible rpms with the propeller installed.

The best initial choice is where the carburation is the richest possible but without an rpm drop.

Following the running-in of the new engine a readjustment will be required.

NOTE: While optimising the carburation, it is necessary that the engine holds maximum rpm for a few seconds during each tachometer reading. For this reason a slightly rich mixture can prevent the risk of engine seizure, which can happen to new engines running lean.

8.3.2 Change in atmospheric pressure and in air temperature

Variations in pressure or temperature cause a change in the air density and consequently a change in the fuel/air ratio and further tuning may therefore become necessary.

A decrease in atmospheric pressure, with consequent decrease in air density, causes a mixture enrichment and smaller needle jet openings will therefore be required.

Altitude variations also produce changes in the carburation and they too cause changes in the air density. Prolonged use of an engine at an altitude higher than 1500 metres (5000 ft approx), for which the carburation was originally set up for operation at around sea level, would require a change of needle jet settings in proportion to the pressure change.

In this case too, a decrease in pressure should be compensated by a reduction of the needle jet openings.

Furthermore, a lowering of air temperature produces an increase in air density and consequently a mixture weakening; therefore an increase in the needle jet openings is required.

Summarising, it can be said that any decrease in air pressure, increase in altitude or in air temperature should be compensated for by a decrease in the needle jet openings.

Conversely, any increase in pressure or decrease in altitude or in temperature should be compensated by an increase in the needle jet openings.

8.3.3 Changes in exhaust system

The carburettor supplied is calibrated to suit a stub pipe exhaust system 73 mm long, if any other exhaust system is fitted, then the carburettor may require recalibration.

8.4 Storage

The storage of the engine is important to both its life and trouble-free operation. Before storage the following procedure should be carried out:

Drain the carburettor by allowing the engine to run at idle speed with the fuel line disconnected, until the engine stops, indicating the carburettor has run dry.

WARNING:

MAKE SURE IGNITION SWITCH IS IN OFF POSITION AND DISCONNECT SPARK PLUG LEADS BEFORE WORKING ON ENGINE.

Clean the exterior of the engine thoroughly and replace the keeper plate on the ignition flywheel.

Remove spark plugs and pour approximately 5cc of the recommended 2-stroke oil (see general data) into each cylinder and crank the engine by hand a few times to spread the oil throughout the cylinders. Replace the spark plugs leaving the spark plug leads disconnected.

During storage crank the engine by hand each month, with the spark plugs removed.

LIST OF REFERENCES

1. Vandiver, J.L., *RPH Preliminary Design, Trend Analysis and Initial Analysis of the NPS Hummingbird*, Master's Thesis, Naval Postgraduate School, Monterey, California, September 1992.
2. Borno, L.M., *Design and Construction of a 1/4 Scale NOTAR System for UAV and Full-Scale Research*, Master's Thesis, Naval Postgraduate School, Monterey, California, March 1993.
3. Fick, G.J., *Aquisition, Design Modification, Assembly, and Ground Test of the NPS Hummingbird Remotely Piloted Helicopter*, Master's Thesis, Naval Postgraduate School, Monterey, California, September 1993.
4. King, R.L., *Evaluation of Alternative Concepts for Rotorcraft Direct-Jet Thrusters for Circulation and Control Anti-torque Systems*, Master's Thesis, Naval Postgraduate School, Monterey, California, September 1993.
5. Booth, A.J., *Final Modification of NPS Hummingbird Remotely Piloted Helicopter in Preparation for Flight*, Master's Thesis, Naval Postgraduate School, Monterey, California, December 1995.
6. Prouty, R.W., Helicopter Performance, Stability, and Control, PWS Publishers, 1986.
7. Taylor, John W.R., Munson, Kenneth, Jane's All the World's Aircraft, Jane's Publishing Company, 730 Fifth Avenue New York, New York, 1980-1981.
8. Taylor, John W.R., Munson, Kenneth, Jane's All the World's Aircraft, Jane's Publishing Company, 730 Fifth Avenue New York, New York, 1981-1982.
9. Taylor, John W.R., Munson, Kenneth, Jane's All the World's Aircraft, Jane's Publishing Company, 730 Fifth Avenue New York, New York, 1982-1983.
10. Incropera, Frank P., DeWitt, David P., Fundamentals of Heat Transfer, John Wiley & Sons, New York, 1985.
11. Blair, Gordon P., The Basic Design of Two-Stroke Engines, Society of Automotive Engineers, Inc., 1990.
12. Weslake Aeromarine Engines Ltd, *Operators Handbook for WAE Limited 342 Engine Series 2100D*, Normalair-Garrett, Ltd., 1985.

13. *Aircraft Spruce and Specialty Company Catalog*, Aircraft Spruce and Specialty, Fullerton, California, 1992-1993.
14. *Grainger's Industrial and Commercial Equipment Supplies Catalog - Fall 1993 General Catalog No. 384*, W.W.Grainger Inc., 1993.

INITIAL DISTRIBUTION LIST

	No. Copies
1. Defense Technical Information Center 8725 John J. Kingman Rd., STE 0944 Ft. Belvoir, VA 22060-6218	2
2. Dudley Knox Library Naval Postgraduate School 411 Dyer Rd. Monterey, CA 93943-5101RPH program.	2
3. Department of Aeronautics and Astronautics, Code AA Naval Postgraduate School Monterey, Ca. 93943-5000	2
4. Professor E. Roberts Wood, Code AA/Wd Department of Aeronautics and Astronautics Naval Postgraduate School Monterey, Ca. 93943-5000	4
5. Professor Richard M. Howard, Code AA/Ho Department of Aeronautics and Astronautics Naval Postgraduate School Monterey, Ca. 93943-5000	1
6. Professor Joshua H. Gordis, Code ME/Go Department of Aeronautics and Astronautics Naval Postgraduate School Monterey, Ca. 93943-5000	1
7. Aerospace Engineering Technician Don Meeks, Code AA/Mk Department of Aeronautics and Astronautics Naval Postgraduate School Monterey, Ca. 93943-5000	2
8. LCDR Robert E. Conway 1417 Second St. Apt. G-202 Coronado, Ca. 92118	3