

**VOLUME I
PERFORMANCE FLIGHT TESTING**

**APPENDIX F
DERIVATIONS**

1962

DTIC QUALITY INSPECTED 4

19970116 068

**USAF TEST PILOT SCHOOL
EDWARDS AFB, CA**

DISTRIBUTION STATEMENT A

**Approved for public release;
Distribution Unlimited**

F.1 DERIVATION OF EULER EQUATION (Chapter 2)

Starting with Newton's Second Law

$$F = ma$$

for an element moving along a streamline with velocity V in the X direction

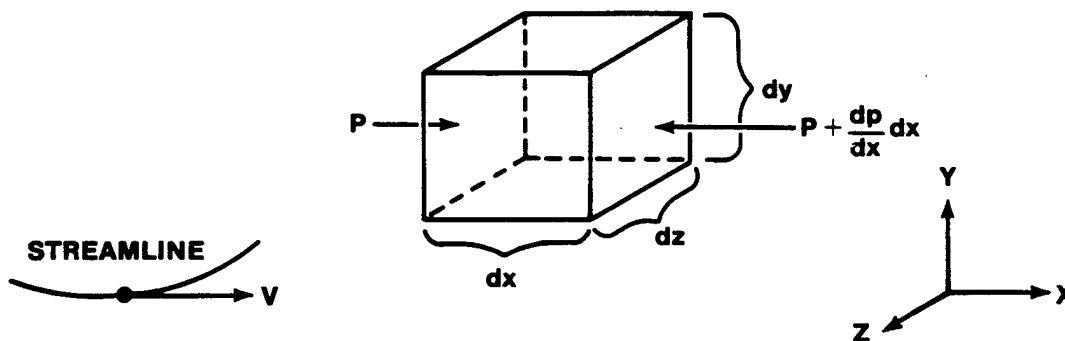

FIGURE F.1.1. FORCES ON A FLUID PARTICLE

$$\Sigma F_x = p dy dz - (p + \frac{dp}{dx} dx) dy dz$$

or

$$F_x = - \frac{dp}{dx} (dx dy dz)$$

$$\text{mass} = (\text{volume}) (\text{density})$$

i.e.,

$$m = \rho (dx dy dz)$$

$$a = \frac{dV}{dt} = \frac{dV}{dx} \frac{dx}{dt} = \frac{dV}{dx} V$$

$$\therefore - \frac{dp}{dx} (dx dy dz) = \rho (dx dy dz) V \frac{dV}{dx}$$

$$\boxed{dp = -\rho V dV}$$

F.2 DERIVATION OF STANDARD ATMOSPHERE RELATIONS (Chapter 5)

Beginning with Equation 5.4 from 5.7

$$\frac{dP_a}{P_a} = - \frac{G}{R T_a} dH$$

Since $T_a = f(H)$ below 36,089 ft due to the lapse rate, L , we can substitute

$$T_a = T_{a_{SL}} - LH = T_{a_{SL}} \left(1 - \frac{L}{T_{a_{SL}}} H \right)$$

Therefore,

$$\frac{dP_a}{P_a} = - \frac{G}{RT_{a_{SL}}} \frac{dH}{\left(1 - \frac{L}{T_{a_{SL}}} H \right)}$$

Upon integration we get

$$\int_{P_{a_{SL}}}^{P_a} \frac{dP_a}{P_a} = \ln \frac{P_a}{P_{a_{SL}}} \tag{F.2.1}$$

and

$$\begin{aligned} - \frac{G}{RT_{a_{SL}}} \int_0^H \frac{dH}{\left(1 - \frac{L}{T_{a_{SL}}} H \right)} &= - \frac{G}{RT_{a_{SL}}} \left[- \frac{T_{a_{SL}}}{L} \ln \left(1 - \frac{L}{T_{a_{SL}}} H \right) - 0 \right] \\ &= \frac{G}{RL} \ln \left(1 - \frac{L}{T_{a_{SL}}} H \right) \end{aligned} \tag{F.2.2}$$

Equate F.2.1 and F.2.2, the two sides of Equation 5.4

$$\ln \left(\frac{P_a}{P_{a_{SL}}} \right) = \frac{G}{RL} \ln \left(1 - \frac{L}{T_{a_{SL}}} H \right)$$

DERIVATION F.2 (Continued)

or

$$\frac{P_a}{P_{a_{SL}}} = \left(1 - \frac{L}{T_{a_{SL}}} H \right)^{G/RL}$$

$$= (1 - K_1 H)^{K_2}$$

Finally, since

$$P_a \propto \rho_a T_a$$

we can get the expression for ρ from

$$\sigma = \frac{\rho_a}{\rho_{a_{SL}}} = \frac{P_a}{T_a} \bigg/ \frac{P_{a_{SL}}}{T_{a_{SL}}} = \left(\frac{P_a}{P_{a_{SL}}} \right) \left(\frac{T_{a_{SL}}}{T_a} \right) = \delta/\theta$$

$$\sigma = \frac{(1 - K_1 H)^{K_2}}{(1 - K_1 H)}$$

$$\sigma = (1 - K_1 H)^{K_2 - 1}$$

Similar derivations can be done for $H > 36,089$ ft.

F.3 DERIVATION OF SPEED OF SOUND (Chapter 6)

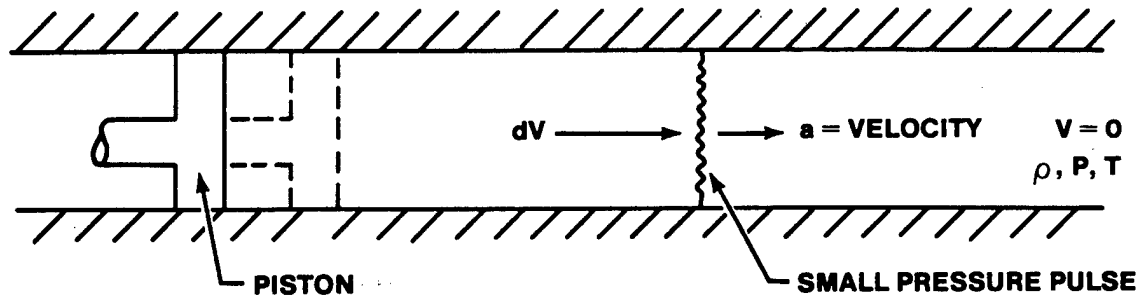

FIGURE F.3.1. PROPAGATION OF A SMALL PRESSURE PULSE IN A FRICTIONLESS PIPE

With the piston stationary the velocity in the pipe is zero, and the fluid has some density, pressure, and temperature. Displacing the piston to the dotted position (an infinitely small distance) causes a small pressure pulse (dP). This small dP travels down the pipe at a speed defined as the speed of sound, a , for the fluid in the pipe. This speed of an infinitely small pressure pulse is also known as acoustic velocity. Behind the pressure pulse the air has a small dV because the piston has displaced the fluid. While not obvious, this fact can be verified experimentally. To analyze this situation mathematically, a coordinate change will be made. Such a change is common in almost all fluid mechanics and aerodynamics courses and is the basis for wind tunnel testing. The math model in Figure F.3.2 transforms to that shown in Figure F.3.3. Notice that the pressure wave in Figure F.3.3 is stationary.

DERIVATION F.3 (Continued)

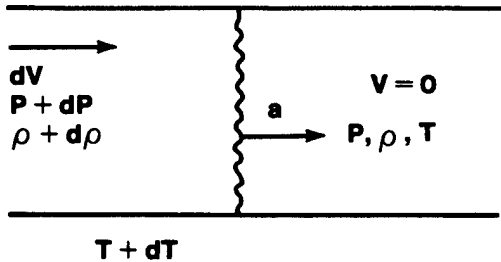

FIGURE F.3.2. MOVING WAVE

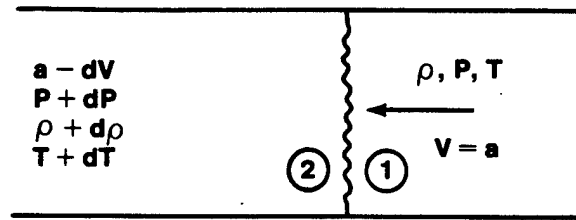

FIGURE F.3.3. STATIONARY WAVE

Evaluating the momentum equation across the pressure pulse from (2) to (1) in Figure F.3.3

$$dP + \rho V dV = 0$$

$$dP = P_2 - P_1 = P + dP - P = dP$$

$$dV = V_2 - V_1 = a - dV - a = -dV$$

Substituting

$$dP + \rho a (-dV) = 0$$

$$dP = \rho a dV \tag{F.3.1}$$

Evaluating the continuity equation across the pressure pulse from (2) to (1) gives

$$\rho AV = \text{Constant}$$

$$(\rho AV)_2 = (\rho AV)_1$$

$$(\rho + d\rho)(a - dV) = \rho a$$

$$\rho a - \rho dV + a d\rho - d\rho dV = \rho a$$

$$d\rho = (\rho/a) dV \tag{F.3.2}$$

DERIVATION F.3 (continued)

Dividing Equation F.3.1 by F.3.2

$$\frac{dP}{d\rho} = \frac{\rho a dV}{(\rho/a) dV}$$

$$\sqrt{\frac{dP}{d\rho}} = a$$

F.4 DERIVATION OF STEADY FLOW ENERGY EQUATION (Chapter 6)

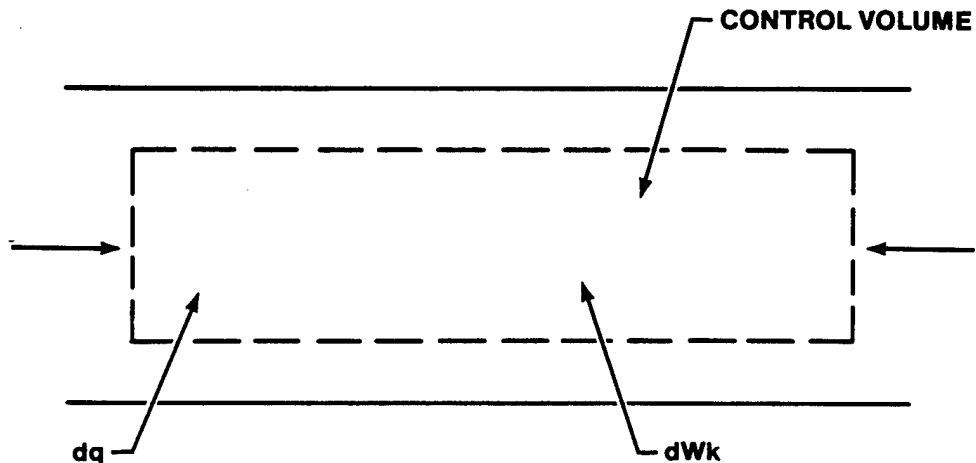

FIGURE F.4.1. CONTROL VOLUME FOR ENERGY BALANCE

$$de = dq - dW \quad (\text{First Law of Thermodynamics}) \quad (\text{F.4.1})$$

$dW \equiv$ Work

$dW_K \equiv$ Shaft work

$dq \equiv$ Heat transfer

$de \equiv$ Energy (Capacity of flow to do work). Several types of energy are possible.

First kinetic energy:

$$KE \equiv \frac{1}{2} mV^2$$

$$d(KE) = mVdV$$

or for a unit mass

$$d(KE) = VdV$$

DERIVATION F.4 (Continued)

A second type of energy is potential energy:

$$d(\text{PE}) = gdz$$

Internal energy is energy due to random motion of the molecules of the fluid. Consider the two fluid molecules in the accompanying sketch.

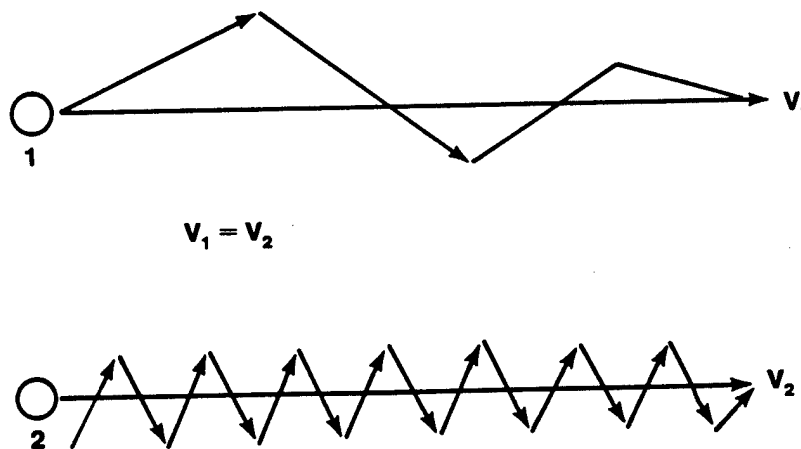

FIGURE F.4.2. MOLECULAR MOTION

The kinetic energy of each molecule is the same, because the average velocities v_1 and v_2 are equal. However, molecule 2 obviously has more random energy and therefore, more energy. This type of energy, called internal energy, u , is solely dependent on absolute temperature. This type of energy is a fluid property.

Expansion and flow work are separated from shaft work and will be written on the energy side of Equation F.4.1 by convention. Expansion work is the work done in order to expand or compress a unit mass of matter

$$d(\text{Expansion Work}) = PdV$$

Flow work is the work done in moving the unit mass of matter

$$D(\text{Flow work}) = v dP$$

DERIVATION F.4 (Continued)

Now, substituting all of these energy and work definitions into Equation F.4.1

$$VdV + gdz + du + Pdv + vdP = dq - dW_K \quad (F.4.2)$$

$$gdz + VdV + du + Pdv + vdP = dq - dW_K$$

But

$$Pdv + vdP = d(Pv) = d\left(\frac{P}{\rho}\right)$$

$$VdV + du + d\left(\frac{P}{\rho}\right) = gdz = dq - dW_K \quad (F.4.3)$$

Recalling the definition of enthalpy

$$h \equiv u + \frac{P}{\rho}$$

$$dh = du + d\left(\frac{P}{\rho}\right)$$

Substituting into Equation F.4.3

$$gdz + VdV = dh = dq - dW_K \quad (F.4.4)$$

Integrating

$$q - W_K = h_2 - h_1 + \frac{v_2^2 - v_1^2}{2} + g(z_2 - z_1) \quad (F.4.5)$$

Potential energy change in our problems can be considered negligible when compared to the kinetic and internal energy changes of our system. In the case of an adiabatic process with no shaft work, Equation F.4.5 reduces to

$$h_2 - h_1 + \frac{v_2^2 - v_1^2}{2} = 0$$

or

$$h + \frac{v^2}{2} = \text{constant} \quad (F.4.6)$$

F.5 RELATIONSHIP BETWEEN M AND M* (Chapter 6)

Starting with Equation F.4.6 in Derivation F.4

$$h + \frac{V^2}{2} = \text{constant}$$

Substituting for h

$$\frac{V^2}{2} + c_p T = c_p T_T = \frac{V^{*2}}{2} + c_p T^*$$

Using $a^2 = \gamma RT$ $a^{*2} = \gamma R T^*$

$$T = \frac{a^2}{\gamma R} \quad T^* = \frac{a^{*2}}{\gamma R} \quad R = c_p - c_v \quad \gamma = \frac{c_p}{c_v}$$

$$\therefore T = \frac{a^2}{\frac{c_p}{c_v} (c_p - c_v)} \quad T^* = \frac{a^{*2}}{\frac{c_p}{c_v} (c_p - c_v)}$$

Substituting into Equation (F.4.6)

$$\frac{V^2}{2} + \frac{c_p a^2}{\frac{c_p}{c_v} (c_p - c_v)} = \frac{V^{*2}}{2} + \frac{c_p a^{*2}}{\frac{c_p}{c_v} (c_p - c_v)}$$

$$\frac{V^2}{2} + \frac{a^2}{\left(\frac{c_p}{c_v} - 1\right)} = \frac{V^{*2}}{2} + \frac{a^{*2}}{\left(\frac{c_p}{c_v} - 1\right)}$$

For local sonic conditions $M = 1.0 = \frac{V^*}{a^*} \quad \therefore V^* = a^*$

$$\frac{V^2}{2} + \frac{a^2}{\gamma - 1} = \frac{a^{*2}}{2} + \frac{a^{*2}}{\gamma - 1} = \frac{(\gamma - 1) a^{*2} + 2a^{*2}}{2(\gamma - 1)}$$

DERIVATION F.5 (Continued)

Dividing by V^2

$$\frac{1}{2} + \frac{a^2}{V^2 (\gamma - 1)} = \frac{a^{*2} (\gamma - 1 + 2)}{V^2 2(\gamma - 1)} = \frac{a^{*2} (\gamma + 1)}{V^2 2(\gamma - 1)}$$

But $M \equiv \frac{V}{a}$ $M^* \equiv \frac{V}{a^*}$

So

$$\frac{1}{2} + \frac{1}{M^2 (\gamma - 1)} = \frac{1}{M^{*2}} \frac{(\gamma + 1)}{2 (\gamma - 1)} \quad \text{(F.5.1)}$$

Solving for M^2

$$\frac{1}{M^2 (\gamma - 1)} = \frac{1}{M^{*2}} \frac{\gamma + 1}{2 (\gamma - 1)} - \frac{1}{2} = \frac{\gamma + 1 - M^{*2} (\gamma - 1)}{2 (\gamma - 1) M^{*2}}$$

Or

$$M^2 = \frac{\frac{2}{\gamma + 1} M^{*2}}{\left[1 - \frac{\gamma - 1}{\gamma + 1} M^{*2} \right]} \quad \text{Now solve F.5.1 for } M^{*2}$$

$$M^{*2} = \frac{(\gamma + 1) M^2}{M^2 (\gamma - 1) + 2}$$

$$\therefore \boxed{M^{*2} = \frac{\frac{\gamma + 1}{2} M^2}{1 + \frac{\gamma - 1}{2} M^2}}$$

F.6 NORMAL SHOCK RELATIONS (Chapter 6)

Assume: Adiabatic flow, thin shock, constant cross-sectional area, properties constant throughout area 1, and throughout area 2

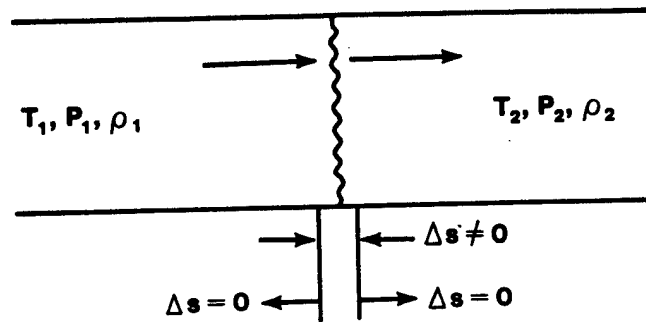

$$\frac{T_{T1}}{T_1} = \left(1 + \frac{\gamma - 1}{2} M_1^2\right)$$

(F.6.1) Since process is adiabatic

$$T_{T1} = T_{T2} = T_T \quad \therefore \text{Divide (F.6.1) by (F.6.2)}$$

$$\frac{T_{T2}}{T_2} = \left(1 + \frac{\gamma - 1}{2} M_2^2\right) \tag{F.6.2}$$

$$\frac{T_2}{T_1} = \frac{1 + \frac{\gamma - 1}{2} M_1^2}{1 + \frac{\gamma - 1}{2} M_2^2} \tag{F.6.3}$$

DERIVATION F.6 (Continued)

$$\text{From continuity } \rho_1 AV_1 = \rho_2 AV_2 \text{ or } \rho_1 V_1 = \rho_2 V_2 \quad (\text{F.6.4})$$

From perfect gas law $P = \rho RT$ or $\frac{P}{RT} = \rho$ Substitute into F.6.4

$$\frac{P_1}{RT_1} V_1 = \frac{P_2}{RT_2} V_2$$

Or

$$\frac{T_2}{T_1} = \frac{P_2 V_2}{P_1 V_1}$$

But

$$M = \frac{V}{a}; \quad V = Ma = M \sqrt{\gamma RT}$$

$$\frac{T_2}{T_1} = \frac{P_2 M_2 \sqrt{\gamma RT_2}}{P_1 M_1 \sqrt{\gamma RT_1}}$$

$$\frac{T_2}{T_1} = \left[\frac{P_2}{P_1} \frac{M_2}{M_1} \right]^2 \quad (\text{F.6.5})$$

Equate (F.6.3) and (F.6.5)

$$\frac{P_2}{P_1} \frac{M_2}{M_1} = \frac{\sqrt{1 + \frac{\gamma - 1}{2} M_1^2}}{\sqrt{1 + \frac{\gamma - 1}{2} M_2^2}} \quad (\text{F.6.6})$$

Use momentum Equation $dP + \rho V dV = 0$ and from continuity of $\rho V = \text{constant}$

$$P + \rho V^2 = \text{const}$$

DERIVATION F.6 (Continued)

$$P_1 + \rho_1 V_1^2 = P_2 + \rho_2 V_2^2$$

$$V = M \sqrt{\gamma RT} \quad \rho = \frac{P}{RT} \text{ again}$$

$$P_1 + M_1^2 \frac{\gamma RT_1 P_1}{RT_1} = P_2 + M_2^2 \frac{\gamma RT_2 P_2}{RT_2}$$

Factoring each side

$$P_1 \left[1 + \gamma M_1^2 \right] = P_2 \left[1 + \gamma M_2^2 \right]$$

$$\frac{P_2}{P_1} = \frac{1 + \gamma M_1^2}{1 + \gamma M_2^2} \quad (\text{F.6.6a})$$

Substitute into Equation F.6.6 and rearrange

$$\frac{1 + M_1^2}{1 + M_2^2} = \frac{M_1}{M_2} \frac{\sqrt{1 + \frac{\gamma - 1}{2} M_1^2}}{\sqrt{1 + \frac{\gamma - 1}{2} M_2^2}} \quad (\text{F.6.7})$$

Solving for M_2^2

$$M_2^2 = \frac{M_1^2 + \frac{2}{\gamma - 1}}{\frac{2\gamma}{\gamma - 1} M_1^2 - 1} \quad (\text{F.6.8})$$

Substituting Equation F.6.8 into Equation F.6.6a and Equation F.6.3 gives

DERIVATION F.6 (Continued)

$$\frac{P_2}{P_1} = \frac{2\gamma}{\gamma + 1} M_1^2 - \frac{\gamma - 1}{\gamma + 1} = \frac{1 - \gamma + 2\gamma M_1^2}{\gamma + 1}$$

$$\frac{T_2}{T_1} = \left[\frac{2\gamma}{\gamma + 1} M_1^2 - \frac{\gamma - 1}{\gamma + 1} \right] \left[\frac{\gamma - 1}{\gamma + 1} + \frac{2}{(\gamma + 1) M_1^2} \right] \quad (\text{F.6.9})$$

ρ_2/ρ_1 can be similarly attained with lots of algebra.

$$\frac{\rho_2}{\rho_1} = \frac{(\gamma + 1) M_1^2}{2 + (\gamma - 1) M_1^2} \quad (\text{F.6.10})$$

F.7 SHOCKS IN SUPERSONIC FLOW: (Chapter 6)

A shock has been described as a discontinuity between supersonic and subsonic flow. Nothing has been said concerning the conditions under which it can or cannot occur. First, the existence of a shock wave must be physically justified, and then the conditions that must exist before a shock will form must be determined.

It will be shown that a shock is a discontinuity between supersonic and subsonic flow and it will be shown that a shock can ONLY occur when flow goes from supersonic to subsonic conditions.

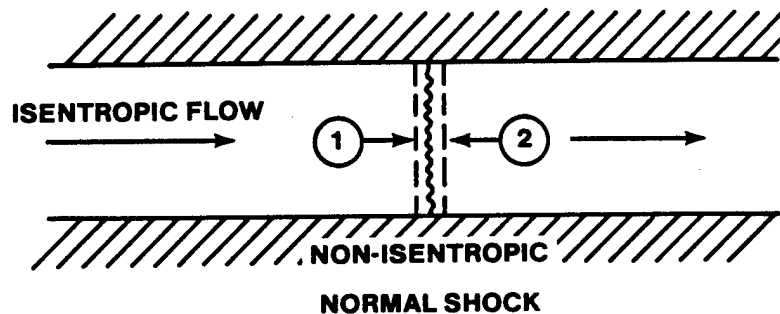

FIGURE F.7.1. NORMAL SHOCK

The mass flow rate through a shock is a constant, i.e., no mass is added or destroyed by the shock, and the cross-sectional area through the shock is assumed constant. Therefore, the continuity and momentum equations may be written

$$\dot{m} = \rho VA = \text{constant} \quad (\text{F.7.1})$$

$$\dot{m} = \rho_1 V_1 = \rho_2 V_2 = \text{constant}$$

$$dP + \rho V dV = 0 \quad (\text{F.7.2})$$

DERIVATION F.7 (Continued)

Evaluating Equation F.7.2 at Stations 1 and 2 (Figure F.7.1) and substituting m for ρV gives

$$P_2 - P_1 = \dot{m} V_1 - V_2$$

Dividing the momentum equation by the continuity equation:

$$\frac{P_2}{\rho_2 V_2} - \frac{P_1}{\rho_1 V_1} = V_1 - V_2 \quad (\text{F.7.3})$$

Multiplying Equation F.7.3 by γ and substituting $a^2 = \frac{\gamma P}{\rho}$

$$\frac{a_2^2}{V_2} - \frac{a_1^2}{V_1} = \gamma (V_1 - V_2) \quad (\text{F.7.4})$$

Writing the energy equation for a point in the free stream and at local sonic conditions:

$$\begin{aligned} c_p T_T &= c_p T + 1/2 V^2 \\ &= c_p T^* + 1/2 V^{*2} \end{aligned} \quad (\text{F.7.5})$$

Substitute the following values for $c_p T$ and V^* into Equation F.7.5:

$$c_p T = c_p \left(\frac{\gamma c_v}{c_p} \right) \left(\frac{R}{c_p - c_v} \right) T = \frac{a^2}{\gamma - 1}$$

$$c_p T^* = \frac{a^{*2}}{\gamma - 1}$$

$$V^* = a^*, \text{ since } M = 1$$

DERIVATION F.7 (Continued)

and solving for a^2

$$a^2 = \frac{\gamma + 1}{2} a^{*2} - \frac{\gamma - 1}{2} V^2 \quad (\text{F.7.6})$$

Substituting this equation into Equation F.7.4 and rearranging (since $a^*_2 = a^*_1 = a^*$)

$$\frac{a^{*2}}{V_1 V_2} (V_1 - V_2) = V_1 - V_2 \quad (\text{F.7.7})$$

If V_1 equals V_2 , Equation F.7.7 has a trivial solution, i.e., $0 = 0$, or that no velocity discontinuity exists in the flow. It is an experimental fact that V_1 does not equal V_2 across a shock and that shock waves are present under certain flow conditions. Dividing by $(V_1 - V_2)$ admits that there is a velocity discontinuity in the mathematical flow description and

$$a^{*2} = V_1 V_2 \quad (\text{F.7.8})$$

a^* is the speed of sound at local sonic conditions and can be shown to be a constant through the shock. The shock is assumed to be an adiabatic process, therefore

$$T_{T1} = T_{T2}$$

and

$$\frac{T^*}{T} = \text{constant} \quad (\text{F.7.9})$$

DERIVATION F.7 (Continued)

Therefore

$$T^*_1 = T^*_2$$

or

$$a^*_1 = a^*_2$$

From Equation F.7.8 it can be seen that if V_1 is greater than a^* , then V_2 must be less than a^* in order for the equality to hold. This can be written

$$\frac{V_1}{a^*} = \frac{a^*}{V_2}$$

and from definition of M^*

$$M^*_1 = \frac{1}{M^*_2} \quad (7.10)$$

Equation F.7.10 shows that if M^*_1 is greater than 1.0, then M^*_1 must be less than 1.0, i.e., if $M^*_1 = 2.0$, then $M^*_2 = .5$.

If there is a velocity discontinuity in the flow, then the velocity on one side of the discontinuity must be subsonic and on the other side must be supersonic. This relationship between M^*_1 and M^*_2 gives no insight as to which side of the shock is subsonic and which side is supersonic.

Supersonic side of shock:

Next it must be established which side of the shock must be supersonic. Experiments have proven that a shock occurs only when the upstream Mach is greater than 1.0, but why? In answer to this question, an equation for the change in entropy has been written

$$dS = c_p \frac{dT}{T} = R \frac{dP}{P}$$

DERIVATION F.7 (Continued)

Integrating and rearranging this expression

$$\frac{\Delta S}{R} = \frac{c_p}{R} \ln T \bigg|_1^2 - \ln P \bigg|_1^2 \quad (\text{F.7.11})$$

where 1 and 2 refer to the stations upstream and downstream of the shock wave. Evaluating this equation with the stagnation properties at Stations 1 and 2.

$$\frac{\Delta S}{R} = \frac{c_p}{R} \ln \frac{T_{T2}}{T_{T1}} - \ln \frac{P_{T2}}{P_{T1}}$$

and since $T_{T2} = T_{T1}$, and $\ln 1 = 0$

$$\frac{\Delta S}{R} = - \ln \frac{P_{T2}}{P_{T1}} \quad (\text{F.7.12})$$

The second law of thermodynamics states that entropy may only increase. Therefore ΔS in Equation F.7.12 is positive.

In P_{T2}/P_{T1} must be negative or $P_{T2}/P_{T1} < 1$. If an equation relating P_{T2}/P_{T1} to M_1 can be derived, the question of which side of a shock wave is supersonic will be solved.

Using Equation F.7.11 to equate the entropy change in terms of free stream conditions to the entropy change in terms of stagnation conditions:

$$- \ln \frac{P_{T2}}{P_{T1}} = \frac{c_p}{R} \ln \frac{T_2}{T_1} - \ln \frac{P_2}{P_1}$$

DERIVATION F.7 (Continued)

Rearranging

$$\frac{P_{T_2}}{P_{T_1}} = \frac{\frac{P_2}{P_1}}{\left(\frac{T_2}{T_1}\right)^{\frac{\gamma}{\gamma-1}}} = \left[\frac{\left(\frac{\rho_2}{\rho_1}\right)^\gamma}{\frac{P_2}{P_1}} \right]^{\frac{1}{\gamma-1}}$$

Substituting in the normal shock equations for P_2/P_1 and ρ_1/ρ_2 and rearranging

$$\frac{P_{T_2}}{P_{T_1}} = \left[\frac{1}{\left(\frac{\gamma-1}{\gamma+1} + \frac{2}{(\gamma+1)M_1^2}\right)^\gamma \left(\frac{2\gamma}{\gamma+1}M_1^2 - \frac{\gamma-1}{\gamma+1}\right)} \right]^{\frac{1}{\gamma-1}} \quad (\text{F.7.13})$$

Substituting into Equation F.7.12 the upstream conditions necessary for an increase in entropy can be determined.

$$\frac{\Delta S}{R} = -\ln \left[\frac{1}{\left(\frac{\gamma-1}{\gamma+1} + \frac{2}{(\gamma+1)M_1^2}\right)^\gamma \left(\frac{2\gamma}{\gamma+1}M_1^2 - \frac{\gamma-1}{\gamma+1}\right)} \right]^{\frac{1}{\gamma-1}} \quad (\text{F.7.14})$$

when

$$M_1 = 1.0; \quad P_{T_2}/P_{T_1} = 1; \quad \Delta S = 0$$

$$M_1 > 1.0; \quad P_{T_2}/P_{T_1} < 1.0; \quad \Delta S \text{ is positive}$$

$$M_1 < 1.0; \quad P_{T_2}/P_{T_1} > 1.0; \quad \Delta S \text{ is negative}$$

The case where $M < 1.0$ is contrary to the requirement that entropy must always increase, consequently it is not possible for a shock to form when the flow goes from subsonic to supersonic velocity.

Notice that when $M = 1$, $\Delta S = 0$. This is the case of the isentropic sound wave or weakest possible normal shock since changes across it are so small that no entropy change is produced.

F.8 LINEAR THIN WING THEORY (ACKERET THEORY) (Chapter 6)

To develop the Ackeret Theory, the following must be satisfied:

1. Geometric and trigometric flow relations
2. Conservation of mass
3. Conservation of momentum

Geometric and Trigometric Relations:

The geometry of an expansion flow is shown in Figure F.8.1. The flow for a compression Mach wave is exactly the same except $d\delta$, dV , and dV_N are negative. Thus the expansion case equations will be valid for the compression case if the signs are reversed. Only the expansion case equations will be developed.

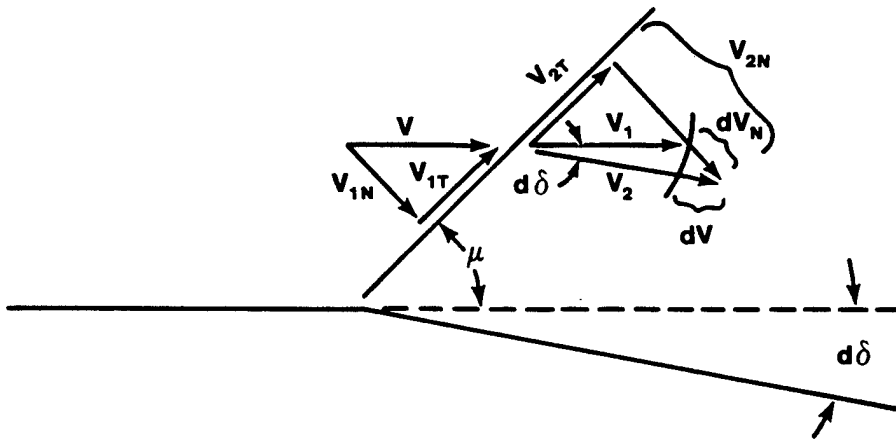

FIGURE F.8.1. EXPANSION FLOW

DERIVATION F.8 (Continued)

Since $d\delta$ is small then

$$dV = \text{change in magnitude of } V = dV_N \sin \mu$$

$$dV_N = \frac{dV}{\sin \mu} \quad (\text{F.8.1})$$

also

$$d\delta = \frac{dV_N \cos \mu}{V} \quad (\text{F.8.2})$$

Substituting Equation F.8.1 into Equation F.8.2

$$d\delta = \frac{dV}{V} \frac{\cos \mu}{\sin \mu} = \frac{dV}{V} \frac{1}{\tan \mu}$$

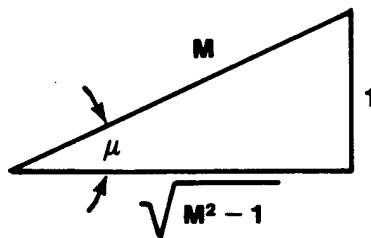

FIGURE F.8.2.

From definition of sine and

$$\sin \mu = \frac{1}{M} \quad (\text{F.8.3})$$

Figure F.8.2 can be constructed. From Figure F.8.2

$$\tan \mu = \frac{1}{\sqrt{M^2 - 1}} \quad (\text{F.8.4})$$

DERIVATION F.8 (Continued)

and

$$d\delta = \frac{dV}{V} \frac{1}{\sqrt{M^2 - 1}}$$

or

$$\frac{dV}{V} = \frac{d\delta}{\sqrt{M^2 - 1}} \quad (\text{F.8.5})$$

Conservation of Mass:

If we consider a constant area across the Mach wave then from the conservation of mass equation

$$\rho_1 V_{1N} = \rho_2 V_{2N} \quad (\text{F.8.6})$$

and

$$\rho_2 = \rho_1 + d\rho$$

$$V_{2N} = V_{1N} + dV_N$$

or

$$\rho_1 V_{1N} = (\rho_1 + d\rho)(V_{1N} + dV_N) \quad (\text{F.8.7})$$

Simplifying Equation 8.7 and dropping $d\rho dV_N$ as insignificant

$$V_{1N} d\rho + \rho_1 dV_N = 0 \quad (\text{F.8.8})$$

Conservation of Momentum:

Parallel to the Mach waves there are no pressure differential forces and thus no momentum flux change parallel to the Mach waves and the conservation of momentum equation becomes

$$(\rho_1 V_{1N}) V_{1T} = (\rho_2 V_{2N}) V_{2T} \quad (\text{F.8.9})$$

DERIVATION F.8 (Continued)

but from conservation of mass

$$\rho_1 V_{1N} = \rho_2 V_{2N} \quad (\text{F.8.6})$$

and

$$V_{1T} = V_{2T}$$

There is a pressure differential normal to the wave and by Newton's second law, this pressure differential per unit area must equal the rate of change of momentum

or

$$(\rho_1 V_{1N}) V_{1N} - (\rho_2 V_{2N}) V_{2N} = P_2 - P_1 \quad (\text{F.8.10})$$

but

$$\rho_1 V_{1N} = \rho_2 V_{2N} \quad (\text{F.8.6})$$

$$V_{2N} = V_{1N} + dV_N \quad (\text{F.8.11})$$

$$P_2 = P_1 + dP \quad (\text{F.8.12})$$

Substituting Equations F.8.6, F.8.11, and F.8.12 into Equation F.8.10 gives

$$V_{1N} dV_N + \frac{dP}{\rho_1} = 0$$

or

$$dV_N = - \frac{dP}{\rho_1 V_{1N}} \quad (\text{F.8.13})$$

DERIVATION F.8 (Continued)

Now we will combine the relationships of the three previous sections. Substituting Equation F.8.13 into Equation F.8.8 gives

$$V_{1N} d\rho - \rho_1 \frac{dP}{\rho_1 V_{1N}} = 0$$

rearranging gives

$$V_{1N}^2 = \frac{dP}{d\rho} = a^2$$

but

$$a^2 = \gamma RT_1 = \gamma \frac{P_1}{\rho_1}$$

Thus

$$V_{1N}^2 = \frac{\gamma P_1}{\rho_1}$$

or

$$\rho_1 = \frac{\gamma P_1}{V_{1N}^2} \tag{F.8.14}$$

Substituting Equation F.8.14 into Equation F.8.13 and rearranging gives

$$dP = \frac{\gamma P_1}{V_{1N}^2} V_{1N} dV_N = - \frac{\gamma P_1}{V_{1N}} dV_N \tag{F.8.15}$$

substituting Equations F.8.1 and F.8.3 into Equation F.8.15 gives

$$dP = - \frac{\gamma P_1}{V_{1N}} M dV$$

Multiply right side by V/V and substituting a for V_{1N} gives

$$dP = - \gamma P_1 M^2 \frac{dV}{V}$$

DERIVATION F.8 (Continued)

Substituting in Equation F.8.5 gives

$$dP = - \frac{\gamma P_1 M^2 d\delta}{\sqrt{M^2 - 1}} \quad (\text{F.8.16})$$

Equation F.8.16 is valid for an expansion and for a compression the equation is

$$dP = - \frac{\gamma P_1 M^2 d\delta}{\sqrt{M^2 - 1}} \quad (\text{F.8.17})$$

If $d\delta$ is small but not infinitesimal, then $d\delta$ becomes δ and dP becomes ΔP .
For an approximation

$$\Delta P = + \frac{\gamma P_1 M^2}{\sqrt{M^2 - 1}}$$

Defining a pressure coefficient

$$C_p \equiv \frac{\Delta P}{q} = \frac{2\delta}{\sqrt{M^2 - 1}} \quad (\text{F.8.18})$$

F.9 DERIVATION OF THRUST EQUATION FOR A TURBOJET (Chapter 7)

The following equations from thermodynamics and physics will be required and are presented here for quick reference.

From gas dynamics for one-dimensional gas flow

$$\frac{T_{\text{TOTAL}}}{T_{\text{STATIC}}} = \frac{T_T}{T} = \left(1 + \frac{\gamma - 1}{\gamma} M^2\right)^{\frac{\gamma}{\gamma - 1}} \quad (\text{F.9.1})$$

$$\frac{P_{\text{TOTAL}}}{P_{\text{STATIC}}} = \frac{P_T}{P} = \left(1 + \frac{\gamma - 1}{2} M^2\right)^{\frac{\gamma}{\gamma - 1}} \quad (\text{F.9.2})$$

For an isentropic process

$$\left(\frac{P_1}{P_2}\right)^{\frac{\gamma - 1}{\gamma}} = \frac{T_1}{T_2} \quad (\text{F.9.3})$$

Mach

$$M = \frac{V}{\sqrt{\gamma RT}} \quad (\text{F.9.4})$$

General thrust equation

$$F_n = \frac{W}{g} (V_{10} - V_0) \quad (\text{F.9.5})$$

DERIVATION F.9 (Continued)

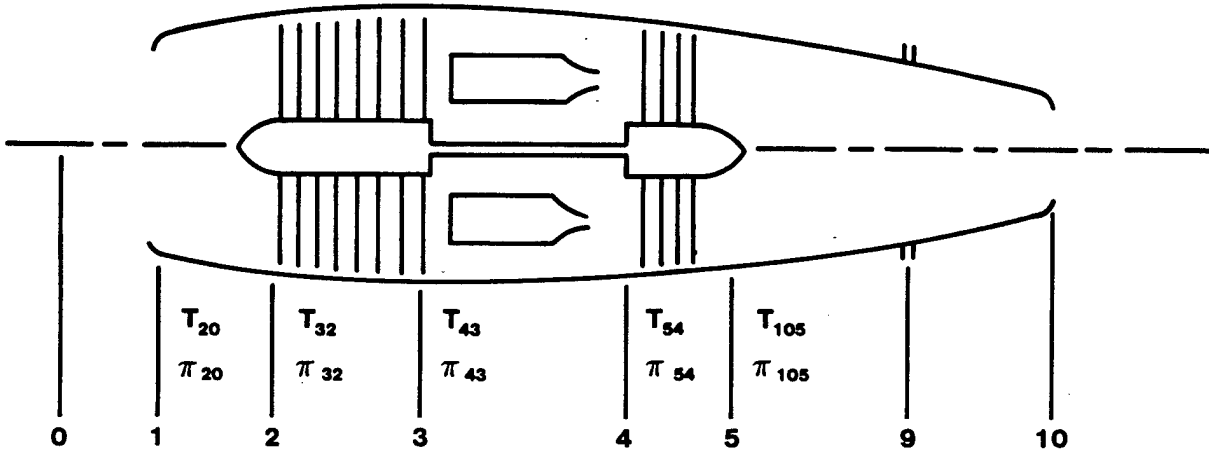

FIGURE F.9.1. STATION DESIGNATIONS AND PARAMETER DEFINITIONS

Define

$$T_{20} = \frac{T_{T2}}{T_0}$$

$$\pi_{20} = \frac{P_{T2}}{P_0}$$

$$T_{32} = \frac{T_{T3}}{T_{T2}}$$

$$\pi_{32} = \frac{P_{T3}}{P_{T2}}$$

$$T_{43} = \frac{T_{T4}}{T_{T3}}$$

$$\pi_{43} = \frac{P_{T4}}{P_{T3}}$$

$$T_{54} = \frac{T_{T5}}{T_{T4}}$$

$$\pi_{54} = \frac{P_{T5}}{P_{T4}}$$

$$T_{105} = \frac{T_{T10}}{T_{T5}}$$

$$\pi_{105} = \frac{P_{T10}}{P_{T5}}$$

NOTE:

$$T_{105} = \pi_{43} = \pi_{105} = 1$$

DERIVATION F.9 (Continued)

Required: $F_n = f$ (temperatures)

Solution:

Apply Equation F.9.1

$$T_{T10} = T_{10} \left(1 + \frac{\gamma-1}{2} M_{10}^2 \right) = T_{10} T_{10} T_{32} T_{43} T_{54} T_{105}$$

and note $T_{105} = 1$

Apply Equation F.9.6

$$P_{T10} = P_{10} = \left(1 + \frac{\gamma-1}{2} M_{10}^2 \right) = P_o \pi_{20} \pi_{32} \pi_{43} \pi_{54} \pi_{105} \quad (\text{F.9.7})$$

and note $\pi_{43} = \pi_{105} = 1$

Assume the nozzle expands gas to ambient pressure so $P_{10} = P_o$.

Equation F.9.7 yields

$$\left(1 + \frac{\gamma-1}{2} M_{10}^2 \right) = \pi_{20} \pi_{32} \pi_{54} \frac{\gamma-1}{\gamma} \quad (\text{F.9.8})$$

From Equation F.9.6

$$\frac{T_{10}}{T_o} = \frac{T_{20} T_{20} T_{32} T_{43} T_{54}}{\left(1 + \frac{\gamma-1}{2} M_{10}^2 \right)} \quad (\text{F.9.9})$$

Combining Equations F.9.8 and F.9.10

$$T_{10} = \frac{\pi_{20} \pi_{32} \pi_{43} \pi_{54}}{\left(P_{20} P_{32} P_{54} \frac{\gamma-1}{\gamma} \right)} \quad (\text{F.9.10})$$

DERIVATION F.9. (Continued)

From Equation F.9.3

$$\pi_{20} \frac{\gamma-1}{\gamma} = T_{20}, \quad \pi_{32} \frac{\gamma-1}{\gamma} = T_{32}, \quad \pi_{54} \frac{\gamma-1}{\gamma} = T_{54}$$

Substituting these expressions into Equation F.9.10

$$\frac{T_{10}}{T_0} = T_{43} \quad (\text{F.9.11})$$

Dividing Equation F.9.9 by Equation F.9.11

$$\left(1 + \frac{\gamma-1}{\gamma} M_{10}^2 \right) = T_{20} T_{32} T_{54}$$

Solve for M_{10}^2 :

$$M_{10}^2 = \left(\frac{2}{\gamma-1} \right) (T_{20} T_{32} T_{54} - 1) \quad (\text{F.9.12})$$

From Equation F.9.1

$$T_{20} = \left(1 + \frac{\gamma-1}{2} M_0^2 \right)$$

Solve for M_0^2 :

$$M_0^2 = \left(\frac{2}{\gamma-1} \right) T_{20} \quad (\text{F.9.13})$$

Dividing Equation F.9.13 by Equation F.9.12

$$\left(\frac{M_{10}^2}{M_0^2} \right) = \frac{T_{20} T_{32} T_{54} - 1}{T_{20} - 1} \quad (\text{F.9.14})$$

DERIVATION F.9 (Continued)

From Equation F.9.4

$$M_{10} = V_{10} \sqrt{\gamma R T_{10}}$$

$$M_0 = V_0 \sqrt{\gamma R T_0}$$

Hence

$$\left(\frac{M_{10}^2}{M_0^2} \right) = \left(\frac{V_{10}^2}{V_0^2} \right) \frac{T_{10}}{T_0} = \left(\frac{V_{10}}{V_0} \right)^2 T_{43} \quad (\text{F.9.15})$$

where Equation F.9.11 was used in the last step.

Combining Equations F.9.15 and F.9.16

$$\left(\frac{V_{10}}{V_0} \right)^2 = T_{43} \left(\frac{T_{20} T_{32} T_{54}}{T_{20} - 1} \right) - 1 \quad (\text{F.9.16})$$

Since $W_c = W_T$

$$h_{T3} - h_{T2} = h_{T4} - h_{T5}$$

$$T_{T3} - T_{T2} = T_{T4} - T_{T5}$$

$$T_{T2} (T_{32} - 1) = T_{T2} T_{32} T_{43} (1 - T_{54})$$

$$T_{54} = 1 - \frac{(T_{32} - 1)}{(T_{43} T_{32})} \quad (\text{F.9.17})$$

Substitute Equation F.9.17 into F.9.16

$$\frac{V_{10}}{V_0} = \sqrt{\frac{T_{20}}{(T_{20} - 1) (T_{43} - 1) (T_{32} - 1) + (T_{43})}} \quad (\text{F.9.18})$$

DERIVATION F.9 (Continued)

From Equation F.9.5

$$F_n = \frac{W}{g} (V_{10} - V_0)$$

$$= \frac{W}{g} V_0 \left(\frac{V_{10}}{V_0} - 1 \right) \quad (\text{F.9.19})$$

Substituting Equation F.9.18 into F.9.19

$$F_n = \frac{W}{g} V_0 \left[\sqrt{\frac{T_{20}}{(T_{20} - 1)} (T_{43} - 1) (T_{32} - 1) + T_{43} - 1} \right] \quad (\text{F.9.20})$$

Equation F.9.20 shows that net thrust is dependent only on three design parameters.

$$T_{43} = \frac{T_{T4}}{T_{T3}} \text{ proportional to fuel flow}$$

$$T_{32} = \frac{T_{T3}}{T_{T2}} \text{ proportional to compressor ratio}$$

$$T_{20} = \frac{T_{T2}}{T_0} \text{ proportional to Mach}$$

If T_{32} approaches 1, a ramjet results and Equation F.9.20 reduces to

$$F_n = \frac{W}{g} V_0 \left(\sqrt{T_{43}} - 1 \right) \quad (\text{F.9.21})$$

What is the static thrust ($M = 0$) of the ramjet and turbojet?

Ramjet:

$$\lim_{M_0 \rightarrow 0} F_n = \lim_{M_0 \rightarrow 0} \left[\frac{W}{g} V_0 \left(\sqrt{T_{43}} - 1 \right) \right]$$

DERIVATION F.9 (Continued)

Note: $V_0 = a M_0$ where a is the speed of sound and T_{43} is independent of Mach

$$= \frac{W}{g} a \left(\sqrt{T_{43}} \right)^{-1} \lim_{M_0 \rightarrow 0} M_0 = 0$$

This, of course, is the expected result as a ramjet does not produce any static thrust.

Turbojet:

$$\lim_{M_0 \rightarrow 0} F_n = \lim_{M_0 \rightarrow 0} \frac{W}{g} V_0 \left[\sqrt{\frac{T_{20}}{(T_{20} - 1)} (T_{43} - 1) (T_{32} - 1) + T_{43} - 1} \right]$$

Since

$$T_{T_2} = T_{T0}$$

$$T_{20} = \frac{T_{T2}}{T_0} = 1 + \frac{\gamma - 1}{2} M_0^2$$

and

$$\frac{T_{20}}{T_{20} - 1} = \frac{1 + \frac{\gamma - 1}{2} M_0^2}{\frac{\gamma - 1}{2} M_0^2}$$

Substituting and simplifying

$$= \frac{W}{g} a \lim_{M_0 \rightarrow 0} \sqrt{\frac{1 + \frac{\gamma - 1}{2} M_0^2}{\frac{\gamma - 1}{2} M_0^2} (T_{43} - 1) (T_{32} - 1) + T_{43} M_0^2 - M_0}$$

DERIVATION F.9 (Continued)

Thus

$$F_{n\text{STATIC}} = \frac{W}{g} a \sqrt{\frac{2}{\gamma - 1} (T_{43} - 1) (T_{32} - 1)} \quad (\text{F.9.22})$$

which shows that unlike the ramjet, the turbojet produces thrust at zero velocity.

F.10 ALTERNATE DERIVATION OF IDEAL NET THRUST EQUATION FOR A TURBOJET
(Chapter 7)

Starting with

$$F_n = \frac{W_a}{g} (V_{10} - V_0) \quad (\text{F.10.1})$$

We want to express F_n in terms of engine parameters and flight conditions.

From cycle analysis

$$V_{10}^2 = 2gJ (h_{T9} - h_{10}) \text{ where } h_{T5} = h_{T9} \quad (\text{F.10.2})$$

$$V_0^2 = 2gJ (h_{T0} - h_0) \text{ where } h_{T0} = h_{T2} \quad (\text{F.10.3})$$

Subtracting Equation F.10.3 from Equation F.10.2

$$V_{10}^2 - V_0^2 = 2gJ [h_{T5} - h_{10} - h_{T2} + h_0] \quad (\text{F.10.4})$$

Since

$$W_c = h_{T3} - h_{T2} = W_T = h_{T4} - h_{T5}$$

then

$$h_{T5} - h_{T2} = h_{T4} - h_{T3} \quad (\text{F.10.5})$$

Substituting Equation F.10.5 into Equation F.10.4

$$\begin{aligned} V_{10}^2 - V_0^2 &= 2gJ [(h_{T4} - h_{10}) - (h_{T3} - h_0)] \\ &= 2gJ C_p [(T_{T4} - T_{10}) - (T_{T3} - T_0)] \\ &= 2gJ C_p \left[T_{T4} \left(1 - \frac{T_{10}}{T_{T4}} \right) - T_0 \left(\frac{T_{T3}}{T_0} - 1 \right) \right] \quad (\text{F.10.6}) \end{aligned}$$

DERIVATION F.10 (Continued)

However for isentropic flow

$$\frac{T_{T3}}{T_{10}} = \left(\frac{P_{T3}}{P_0} \right)^{\frac{\gamma - 1}{\gamma}} \quad (\text{F.10.7})$$

$$\frac{T_{T4}}{T_0} = \left(\frac{P_{T4}}{P_{10}} \right)^{\frac{\gamma - 1}{\gamma}} = \left(\frac{P_{T3}}{P_0} \right)^{\frac{\gamma - 1}{\gamma}} \quad (\text{F.10.8})$$

since for an ideal process

$$P_{T3} = P_{T4}$$

and

$$P_{10} = P_0$$

Substituting Equations F.10.8 and F.10.7 into Equation F.10.6 and subtracting V_0^2 ,

$$V_{10}^2 = 2gJ C_p \left\{ T_{T4} \left[1 - \left(\frac{P_0}{P_{T3}} \right)^{\frac{\gamma - 1}{\gamma}} \right] - \left[T_0 \left(\frac{P_{T3}}{P_0} \right)^{\frac{\gamma - 1}{\gamma}} - 1 \right] \right\} V_0^2 \quad (\text{F.10.9})$$

Note

$$\frac{P_{T3}}{P_0} = \frac{P_{T3}}{P_{T2}} \cdot \frac{P_{T2}}{P_{T1}} \cdot \frac{P_{T1}}{P_0} = CR \left(1 + \frac{\gamma - 1}{\gamma} M_0^2 \right) = CR f(M)$$

The last term is the ram recovery, $f(M)$

DERIVATION F.10 (Continued)

Solving for V_{10} ; $T_{T4} = TIT$ in Equation F.10.9,

$$V_{10} = \sqrt{2gJC_p \left\{ TIT \left[1 - \left(\frac{1}{CR f(M)} \right)^{\frac{\gamma-1}{\gamma}} \right] - T_0 \left[(CR f(M))^{\frac{\gamma-1}{\gamma}} - 1 \right] \right\} V_0^2} \quad (F.10.10)$$

Hence from Equations F.10.1 and F.10.10

$$F_n = \frac{W_a}{g} \left[\sqrt{2gJC_p \left\{ TIT \left[1 - \left(\frac{1}{CR f(M)} \right)^{\frac{\gamma-1}{\gamma}} \right] - T_0 \left[(CR f(M))^{\frac{\gamma-1}{\gamma}} - 1 \right] \right\} V_0^2} \right] V_0 \quad (F.10.11)$$

$$= f (TIT, CR, M_0, T_0)$$