

**VOLUME I
PERFORMANCE FLIGHT TESTING PHASE**

**CHAPTER 3
LOW L/D**

19970116 089

DTIC QUALITY INSPECTED 4

JANUARY 1992

**USAF TEST PILOT SCHOOL
EDWARDS AIR FORCE BASE, CALIFORNIA**

DISTRIBUTION STATEMENT A

Approved for public release;
Distribution Unlimited

Many of the research aircraft flown since the late 1940s have been air launched, rocket powered vehicles which have been landed power-off on one of the dry lakebeds in the Edwards complex. Most of the landing patterns for these aircraft have been characterized by high airspeeds, high descent rates, and low lift to drag ratios. Pattern shapes have not been consistent. That is, some aircraft entered on a base leg with only a 90-degree turn to final; some straight in approaches have been flown; also, 180°, 270°, and 360° patterns have been used. Pattern characteristics have been dictated by the aircraft performance, operational policies, and data requirements. However, whatever the characteristics, it is obvious from the high risk of power off approaches that a simulator aircraft for practicing approaches is an absolute safety requirement. Simulation is especially important prior to the first flight of a new aircraft, or prior to the checkout flight of a new pilot in a proven aircraft. Also, the frequency of flights of air launched vehicles is usually low (not more than two flights per month). Therefore, simulation is valuable for maintaining proficiency in these types of approaches in between actual test flights.

These notes have been written to explain the airborne simulation procedures used for the X-24B research aircraft. They cover the areas of the X-24B envelope which are simulated, the procedure used for selecting a simulator aircraft, and the simulation profiles flown. Considerations for simulation of flame-out approaches of other aircraft are also covered.

Finally, recommendations are made concerning the use of similar profiles by the USAF Test Pilot School.

It is desirable to simulate as much of the flight envelope of the experimental aircraft as possible. However, the flight characteristics and performance of aircraft like the X-24B make simulation of much of the envelope impossible. The X-24B is flown in two basic configurations, transonic and subsonic. These configurations are dictated by the requirement to maintain directional stability as flow breakdown occurs around the vertical fins. Above 0.7 Mach the upper flaps are biased open to 40 degrees and the lower flaps provide pitch control by operating open between 20 and 25 degrees for most angles of attack (see Figure 1). In this configuration, the rudders are biased to zero degrees. Below 0.7 Mach, the upper flaps are biased open to 20 degrees and the rudders are biased to 10 degrees toe in. Pitch control is provided by the lower flaps operating between 0 and 15 degrees. At higher angles of attack, the lower flaps are closed all the way and pitch control is then provided by the upper flaps moving open and closed in response to control stick longitudinal motions. These flap bias positions are controlled by a speed brake switch located on a T-33 aft cockpit throttle which is mounted on the left console of the X-24B cockpit. During the landing pattern, the flaps are used as a speed brake to provide very effective glide slope and airspeed control by being biased in and out to intermediate settings.

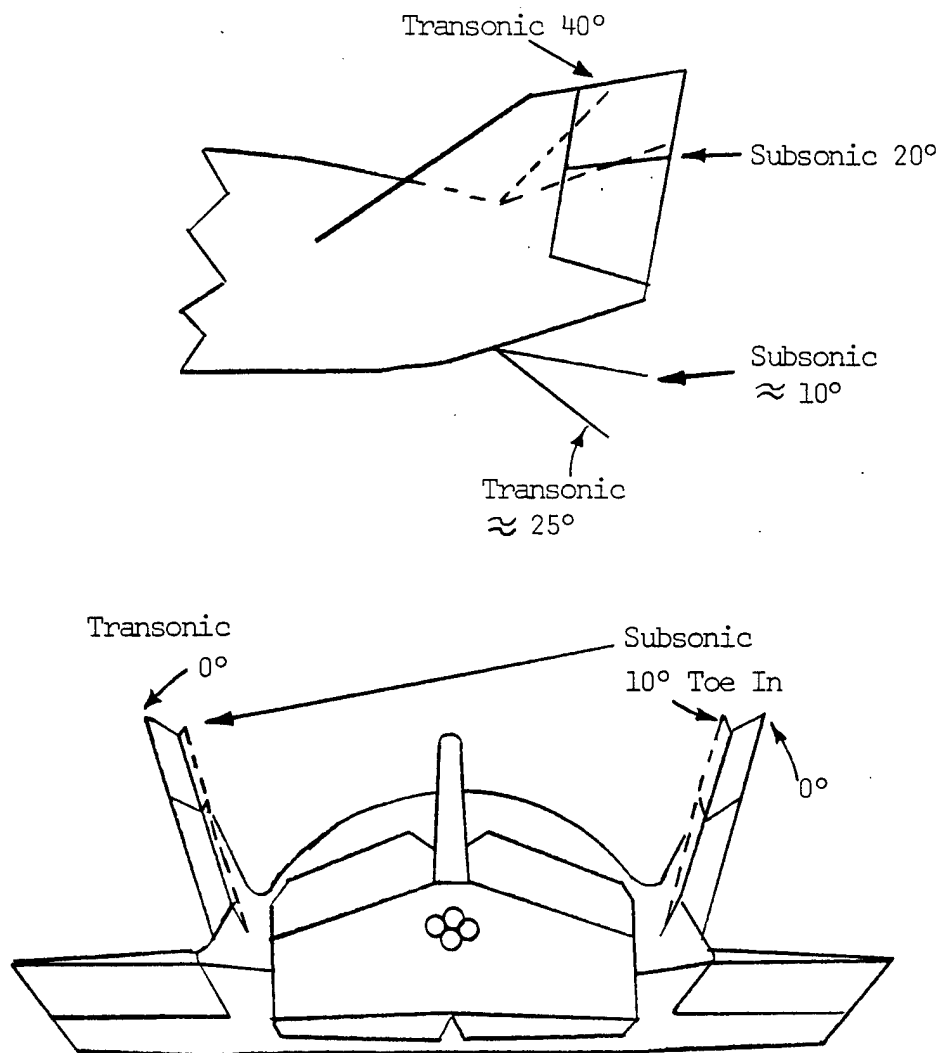

X-24B
 TRANSONIC AND SUBSONIC
 FLAP AND RUDDER CONFIGURATIONS

FIGURE 1

Both these configurations are high drag configurations compared to present day fighters. The transonic configuration (40 degree upper flap bias) has a maximum lift to drag ratio (L/D) of about 2.5, and the subsonic configuration (20 degree upper flap bias) has a maximum L/D of 4.0. This means that a suitable simulator aircraft for the X-24B must be able to match these L/D ratios at the same airspeeds flown by the test aircraft. In terms of a glide flight profile in the transonic configuration, this can be translated into the ability to descend from 45,000 feet to 30,000 feet in 75 seconds, while maintaining indicated airspeeds between 185 and 215 knots. Generally speaking, the subsonic configuration is used from 30,000 feet to the surface with airspeed and L/D varying from 200 KIAS to 300 KIAS and 4.0 to 2.5 respectively. Simulation of this portion of the flight envelope can be done fairly accurately as will be discussed in more detail later.

The boost portion of a powered flight profile does not lend itself to simulation with a fighter aircraft. After launch from 45,000 feet and 190 KIAS, the angle of attack is maintained at 15 degrees while the engine is ignited. The aircraft is then rotated at that angle of attack until the initial descent is arrested and the climb begins. This takes two to three thousand feet. During the rotation and ignition sequence, the airspeed builds to around 260 KIAS with a maximum Mach of approximately 0.9 Mach. A constant angle of attack is maintained to a preplanned climb angle, after which, a constant climb angle is maintained while the indicated airspeed is allowed to decrease. It decreases as low as 140 KIAS on some profiles. At

a predetermined indicated Mach, the aircraft is pushed over to 5 degrees angle of attack to accelerate. Maximum Mach is around 1.5 and maximum altitude 70,000 feet. After burnout, the initial portion of the descent is then flown at low angles of attack with a high rate of descent around 25,000 feet per minute. This rate of descent is continued during data maneuvers until approximately 30,000 feet where the change to the subsonic configuration is made to fly the landing pattern.

The fidelity of the simulation during the flare for landing is also questionable. Stick forces and displacement, visibility over the nose, the degree of aircraft rotation, and the airspeed bleed rate all vary from aircraft to aircraft during this maneuver. Therefore, it is not likely that a fighter can be flown in a manner which will precisely duplicate the test aircraft performance or handling qualities during the deceleration and touchdown.

During the X-15, M2, HL-10, and X-24A flight test programs, the F-104 aircraft was used as a simulator aircraft by both the Air Force and NASA. However, the Air Force F-104s were phased out of the inventory between the completion of the X-24A and the beginning of the X-24B programs. This made it necessary for the Air Force to select a replacement aircraft from available Flight Test Center resources - the F-4 or T-38. The following factors were considered in choosing the T-38 for the job:

1. L/D Spectrum. The T-38 was found to have a more favorable L/D spectrum. The F-4 will not glide at sufficiently low L/D ratios in any usable configuration. The correct L/D can be obtained by carrying empty rocket pods, but this was not considered a usable configuration because of the need to repeatedly upload and download the pods. The F-4 can also attain the desired L/D ratios with gear down, speed brakes down and full flaps with the flap blowup switch deactivated. However, it was discovered that with the speed brakes and flaps down the flap actuators fail, causing damage to the wings and flaps. With gear down, full flaps and the flap blowup switch deactivated, no damage occurs, but the flaps physically retract at around 230 KIAS. In addition, if the F-4 were flown frequently at 300 KIAS with the gear down, the gear doors would have to be modified to strengthen them. With gear down and speed brakes out, the T-38 will adequately simulate the X-24B subsonic configuration. It will also do it with gear down, speed brakes out and 45 percent flaps. No modifications are required to fly at 300 KIAS with the gear down, and no gear door problems have occurred in six years of experience at the Flight Test Center or during the space shuttle simulations conducted by NASA Houston in 1970. Gear is extended and retracted below 240 KIAS, however.

2. Handling Qualities. Both the F-4 and T-38 aircraft were considered to have adequate handling qualities for the simulation of the X-24B subsonic configuration. In this case, it is not meant that the F-4 or T-38 handling qualities simulate those of the X-24B. It simply means

that the F-4 or T-38 handling qualities are such that in either aircraft the pilot workload would be low enough during the simulation that both aircraft would be safe for that task. The T-38 handling qualities were considered better than those of the F-4.

3. Availability and Sortie Rate. Although fewer T-38 aircraft than F-4s were possessed by the Flight Test Center, it was considered more attractive because of its demonstrated high sortie rate. Also, the T-38 was in less demand for high priority support missions, such as F-15 chase.

4. Cost. The T-38 was more attractive because cost per flying hour was only 40 percent of the F-4 cost.

The T-38 simulation is not as satisfactory as the F-104. This is because the T-38 cannot accurately simulate the X-24B transonic configuration (Figure 2). This means that the entire glide flight profile from launch to touchdown cannot be simulated. More important, abort profiles for powered flights cannot be duplicated. The T-38 cannot attain the high rate of descent which the F-104 can with gear down, land flaps down, speed brakes out and idle power. This means that the pilot cannot experience the high energy dissipation rate which is required when an abort is made from close in to an emergency runway. This inadequacy has been partially overcome in the X-24B program by NASA providing training in the abort profiles for the Air Force pilot in their two-seat F-104B.

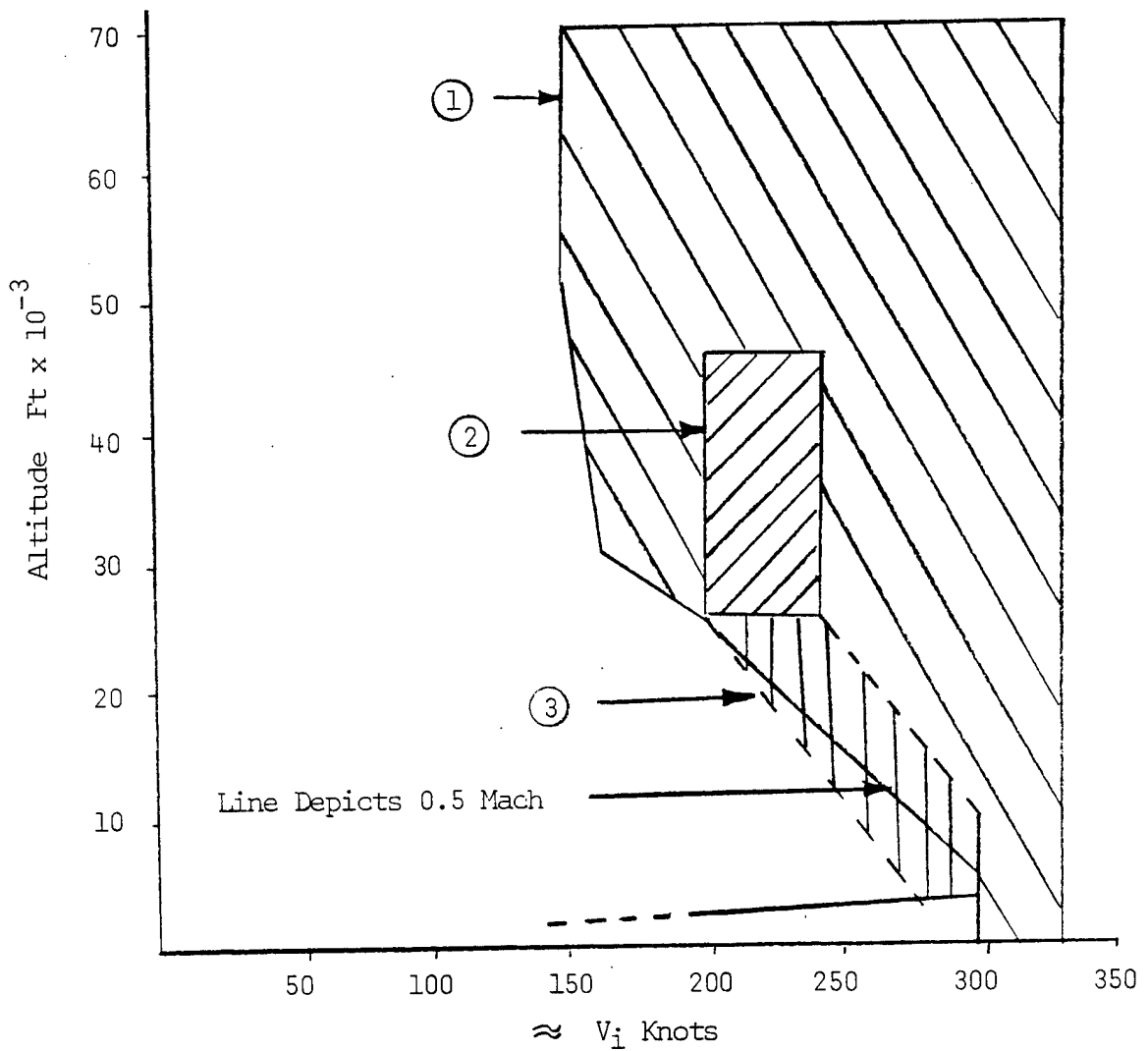

ENVELOPE OVERLAY X-24B, F-104, T-38

①  Exclusive X-24B envelope.

②  F-104 simulation possible with gear and land flaps down, speed brakes out, idle RPM. Simulates transonic configuration of X-24B up to 240 KIAS, the land flap airspeed limit.

③  T-38 or F-104 simulation possible.
 T-38, gear down, speed brakes out, RPM for L/D.
 F-104, gear and takeoff flaps down, speed brakes out, RPM for L/D. Simulates X-24B subsonic configuration at 0.5 Mach.

FIGURE 2

After determining that the T-38 could definitely simulate the X-24B subsonic configuration, it was necessary to establish the RPM versus airspeed relationships as a function of gross weight (Figure 3). This was done by calculating predicted RPM settings based on idle thrust and J-85 engine data. These RPM settings were then confirmed by flying formation sawtooth descents with a NASA F-104 for which accurate RPM settings had previously been established. (The NASA F-104 RPM settings have since been confirmed as accurate during descents in formation with the X-24B.)

T-38 CONFIGURATION
GEAR AND SPEED BRAKES

X-24B Simulation. $\delta U_B = -20^\circ$ $\delta R_B = -10^\circ$ $\delta A_B = 7^\circ$

Mach = 0.5

Fuel Remaining (lbs)	210 KCAS	260 KCAS	310 KCAS
	% RPM	% RPM	% RPM
3,000	72.0	70.5	73.5
2,500	74.5	74.0	76.5
2,000	75.5	77.5	81.0
1,500	77.0	79.5	85.0
1,000	78.5	83.0	88.5
500	80.0	85.5	90.5
Alt =	25K	15K	5K

FIGURE 3

The predicted RPM settings were obtained in the following manner: Wind tunnel lift and drag data for the X-24B were combined in a plot of L/D versus $\frac{C_L S}{W}$ and $\frac{V_e}{\sqrt{n_Z}}$ at various Mach numbers (Figure 4). The L/D of the vehicle defines the flight path angle. The goal, then, in plotting L/D versus the above parameters is to allow the comparison of aircraft with different wing loadings and centers of gravity at the same L/D, load factor, and equivalent airspeed. Center of gravity is not a significant factor in the plots for fighter aircraft such as the T-38, F-104, or F-4. However, it is important for the X-24B because of the significant change in trim drag with a change in center of gravity.

A similar plot for the T-38 was then made based on flight test values of lift and drag obtained at the chosen Mach number and altitudes. Note that this L/D is an effective L/D which includes thrust effects. The X-24B pattern is flown near 0.5 Mach number from 25,000 feet to 5,000 feet. Therefore, RPM settings were established for 25,000, 15,000, and 5,000 feet at 0.5 Mach and various increments of fuel remaining. Lift and drag data for these conditions could be obtained from wind tunnel data, flight test data from the Category II performance flight tests, or from flight test data obtained in sawtooth descents performed at idle thrust in various configurations. However, the latter source is probably the most accurate and available because data at such unusual altitudes and Mach numbers for the required configurations is not available. That is, the Category II test team probably found little need to determine the performance of the T-38 at 0.5 Mach and 10,000 feet with gear down and speed brakes out.

X-24B, 60% CG, W/S = 25.04 psf, Wind Tunnel Data
 F-4C, W/S = 61.04 psf, 2,000 lbs Fuel, Cat II Drag Data - Wind Tunnel Data
 F-38, W/S = 59.44 psf, 2,000 lbs Fuel, Sawtooth Descents

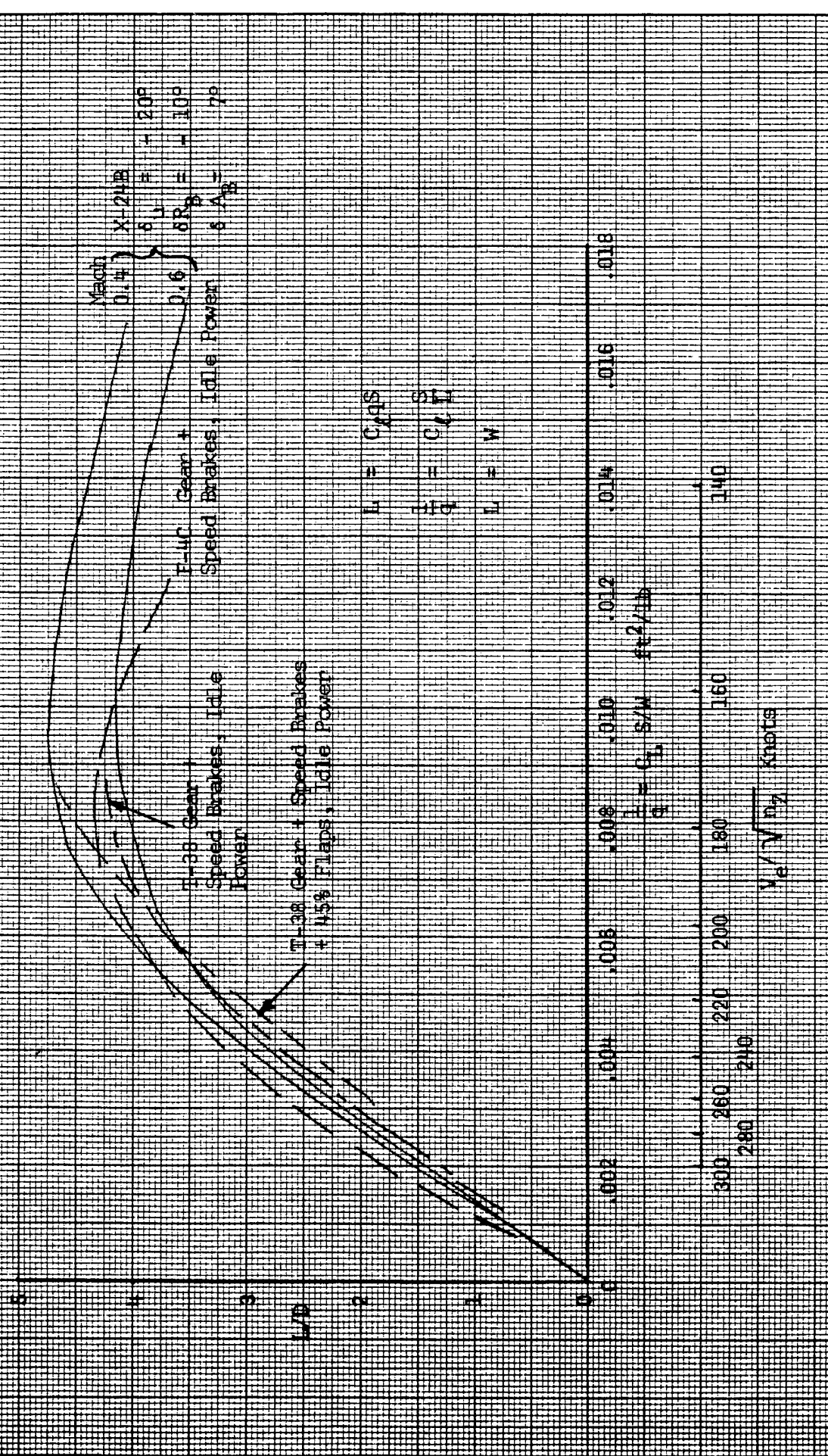
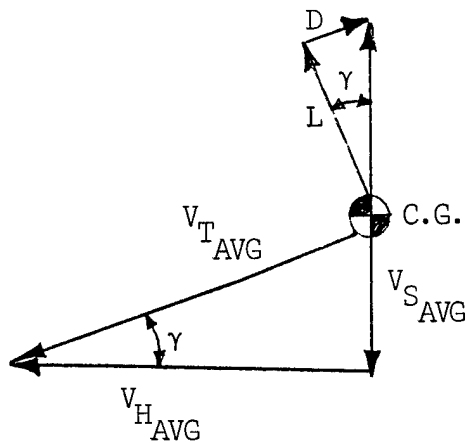

FIGURE 6. PERFORMANCE OF THE X-24B, F-38 and F-4C

The L/D of the T-38 was directly available from the average sink speed and the average true airspeed flown during the sawtooth descents. The relationships for obtaining L/D directly can be illustrated graphically.



- γ - Flight Path Angle
- L - Lift
- D - Drag
- $V_{S\text{AVG}}$ - Average Sink Speed
- $V_{H\text{AVG}}$ - Average Horizontal Speed
- $V_{T\text{AVG}}$ - Average True Speed

Sawtooth descents at constant indicated airspeed can be used to determine average true airspeed and sink speed over an altitude band. From these values, the flight path angle can be determined. Then

$$\frac{L}{D} = \text{COT } \gamma$$

An alternate, and perhaps more efficient, sawtooth descent is a descent at constant indicated Mach using a real time printout of flight path angle. These descents should be made perpendicular to the known winds in both directions and the wind correction of the computer program should be used (RADAPS, DECK 4001).

After L/D is obtained as a function of gross weight, C_L should be computed as a means for determining the effective drag coefficient at idle thrust, $C_{D_{EFF_{IDLE}}}$. The relationships for this are

$$V_e = \frac{V_e}{M} M$$

$$q = \frac{V_e^2}{2qS}$$

$$C_L = \frac{nW}{qS}$$

$$C_{D_{EFF_{IDLE}}} = \frac{C_L D}{L}$$

Using the plot of L/D vs $C_L S/W$, the L/D of the T-38 can be obtained as function of gross weight and equivalent airspeed using these relationships

$$V_e = \frac{V_e}{M} M$$

(M is the chosen Mach number for the simulator and V_e/M is a function of altitude, see page 126 of Flight Test Engineering Handbook)

$$q = \frac{V_e^2}{2qS}$$

V_e is in knots
 q is in psf

$$C_L S/W = \frac{1}{q}$$

The lift coefficient, C_L , and the effective drag coefficient at idle thrust, $C_{D_{EFF_{IDLE}}}$, of the T-38 are calculated from

$$C_L = \frac{nW}{qS} \quad n = \cos \alpha \text{ or can assume } n = 1$$

$$C_{D_{EFF_{IDLE}}} = C_L \frac{1}{L/D}$$

The desired T-38 drag coefficient $C_{D_{EFF_{IDLE}}}$ is determined from the desired L/D at these conditions (Mach and V_e), which is the X-24B L/D. Then $C_{D_{EFF_{DESIRED}}} = \frac{C_L D}{L}$ at the desired X-24B L/D. The needed reduction in drag coefficient is then

$$\Delta C_D = C_{D_{EFF_{IDLE}}} - C_{D_{EFF_{DESIRED}}}$$

The reduction in drag coefficient is accomplished by adding thrust.

$$\Delta F_N = \Delta C_D qS$$

$$\text{Then } \Delta F_N + F_{N_{IDLE}} = F_{N_{REQUIRED}}$$

The RPM for the required thrust is determined from the engine curves as a function of Mach and altitude (Figures 5, 6, 7, 8). In the case of the F-4, the effective drag coefficient at idle is too low for X-24B simulation with gear down and speed brakes out. Therefore, at the required altitudes and Mach number, the F-4 cannot be used as an X-24B simulator without the addition of another drag device.

J85-GE-5
 STANDARD DAY
 M = 0.5
 THRUST PER ENGINE

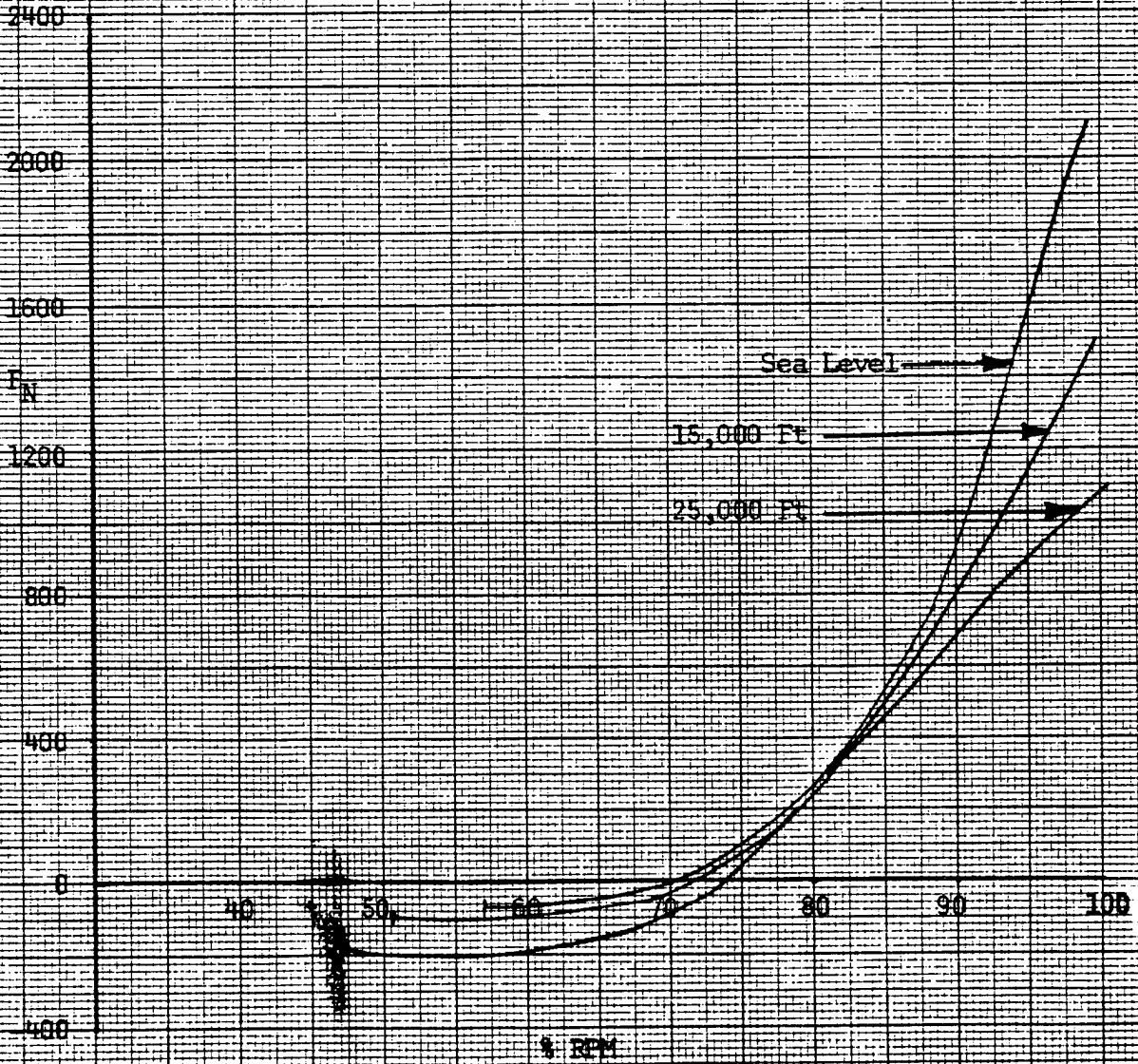

FIGURE 5

J85-CE-5
SEA LEVEL
STANDARD DAY
T = 59.12°F

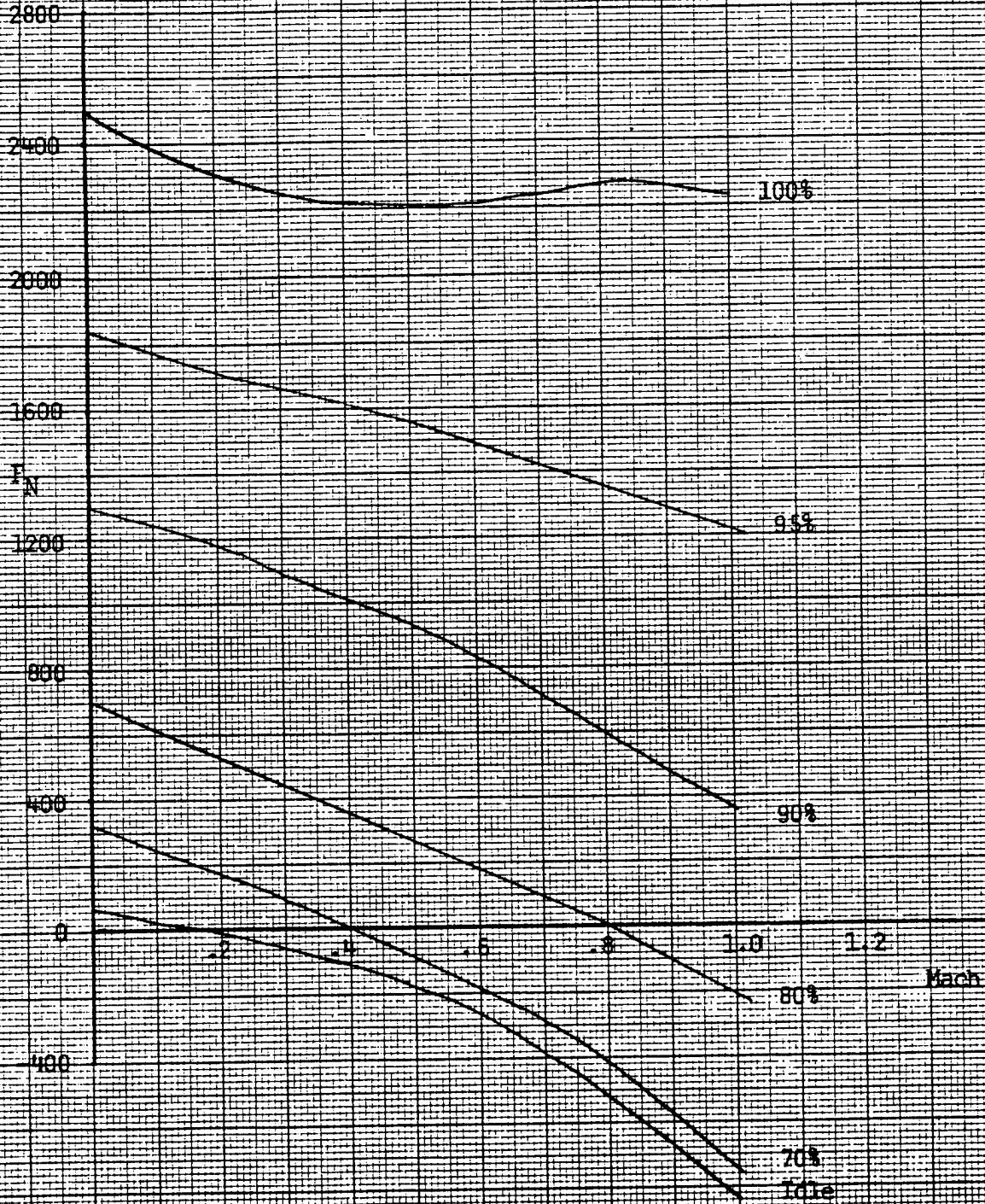

FIGURE 6

J85-GE-5
15,000 FC
STANDARD DAY
T = 5.62°F

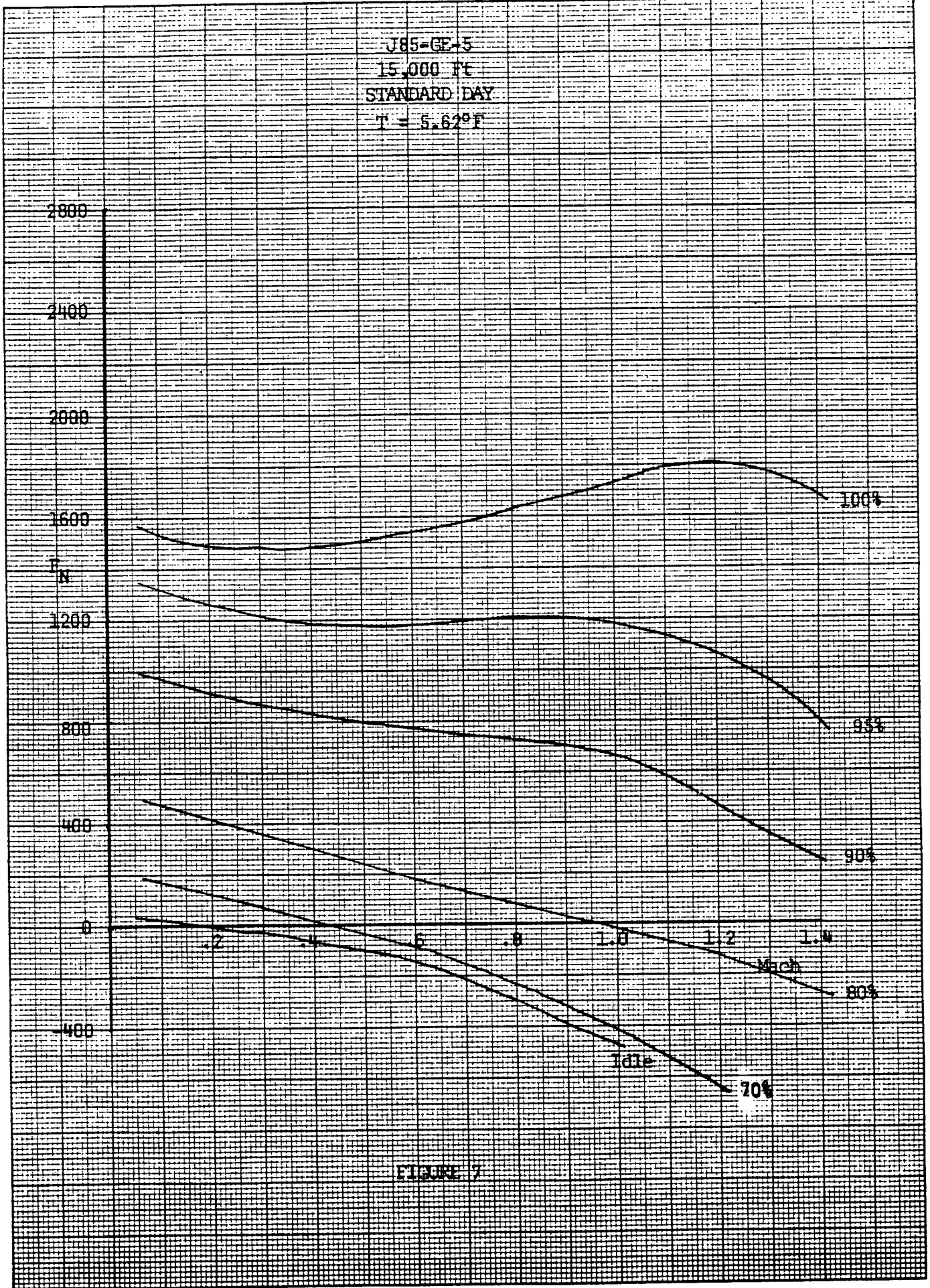

FIGURE 7

T85-CF-6
25,000 Lb
STANDARD DAY
T₀ = 30.08°F

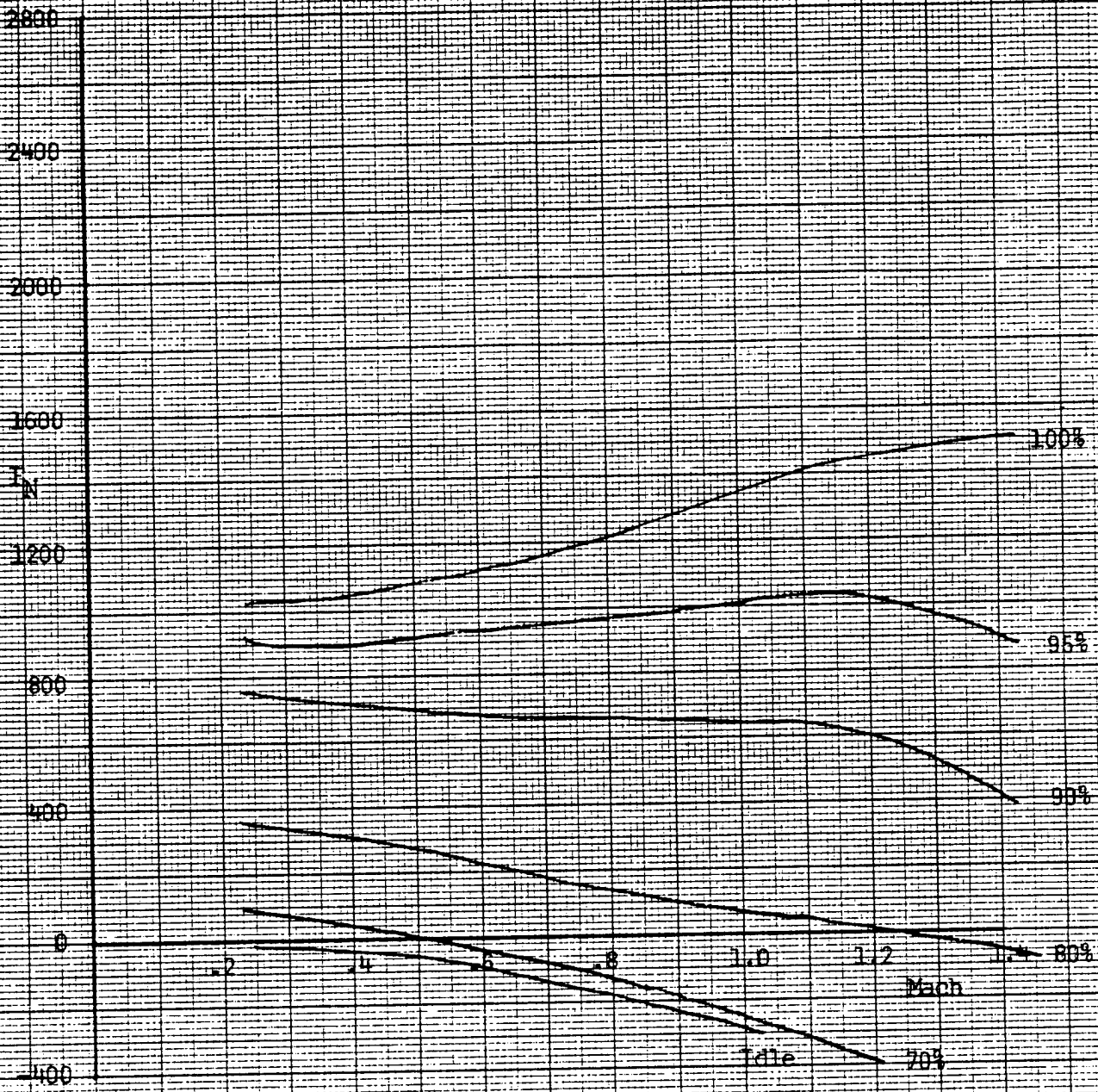

FIGURE 8

Two methods can be used to simulate a constant glide path angle (L/D) as the gross weight changes. The first is to vary RPM; the second is to vary airspeed. In the X-24B simulation, we want to maintain the same pattern airspeeds, so we vary the RPM to maintain L/D constant.

An examination of Figure 3 shows that to maintain a constant L/D at a constant indicated airspeed, it is necessary to increase RPM as aircraft gross weight is decreased. Figure 9 illustrates this relationship in a slightly different manner. In this case, L/D is shown to vary as a function of gross weight and equivalent airspeed at a constant Mach number of 0.5 and idle thrust. Therefore, under these conditions, decreasing indicated airspeed must be flown to fly at a constant L/D.

Sailplane operations provide another insight into this concept. The maximum L/D capability of a given sailplane is defined by its aerodynamic efficiency, and is not a function of its gross weight. Therefore, a two seat sailplane can attain the same maximum L/D with one or both cockpits filled (Figure 10). However, it must be flown at different airspeeds to keep the L/D constant. At the higher airspeed for the higher gross weight, the increase in drag is offset by the increased thrust component of the weight which is pointed down the flight path. During X-24B simulation, the airspeed is held constant (instead of slowing down) and the required thrust vector is provided by the engine(s), rather than by aircraft weight.

T-38 L/D vs $V_p/\sqrt{T_z}$

As a Function of Fuel Remaining in Pounds - 0.5M
IDLE THRUST

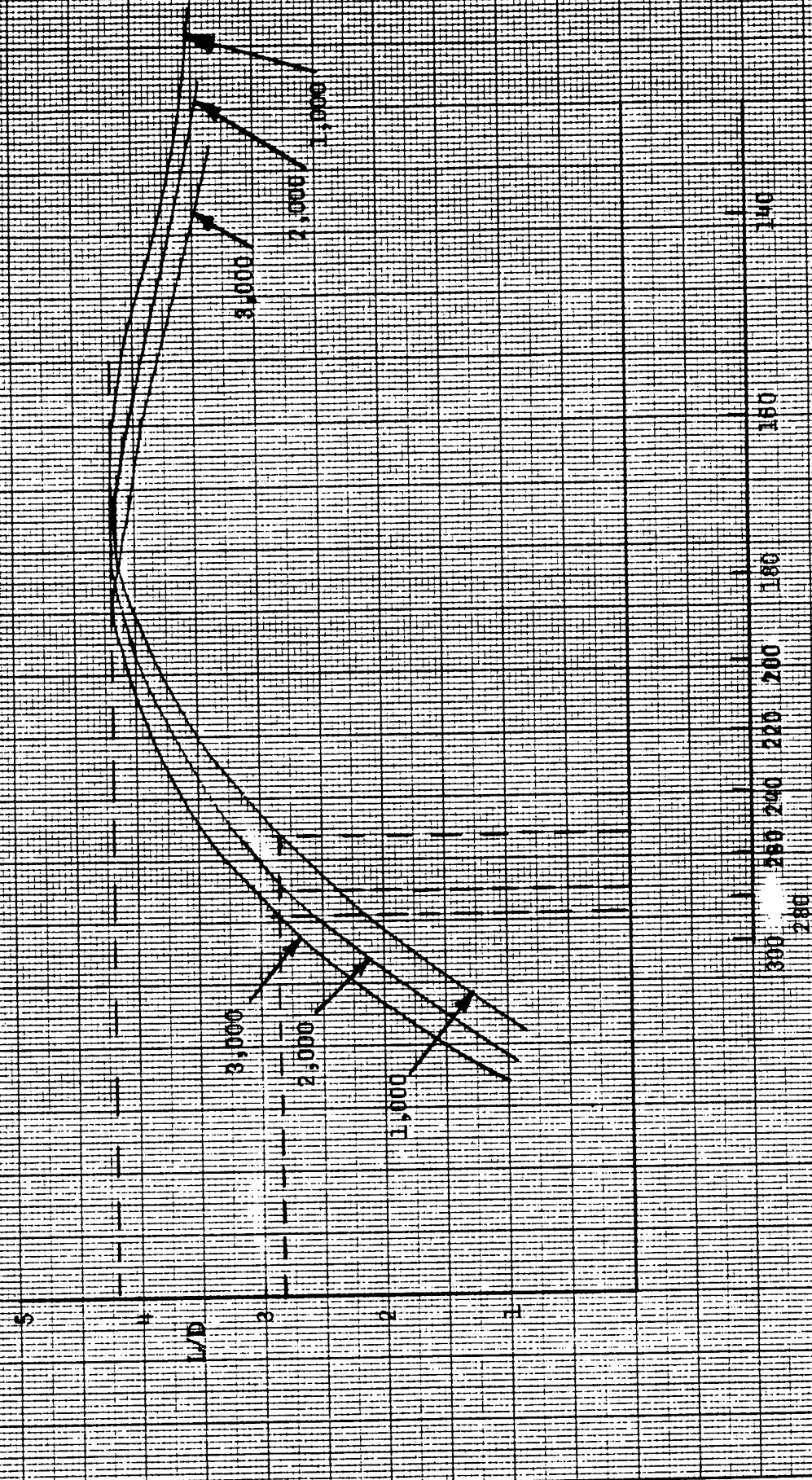

FIGURE 9

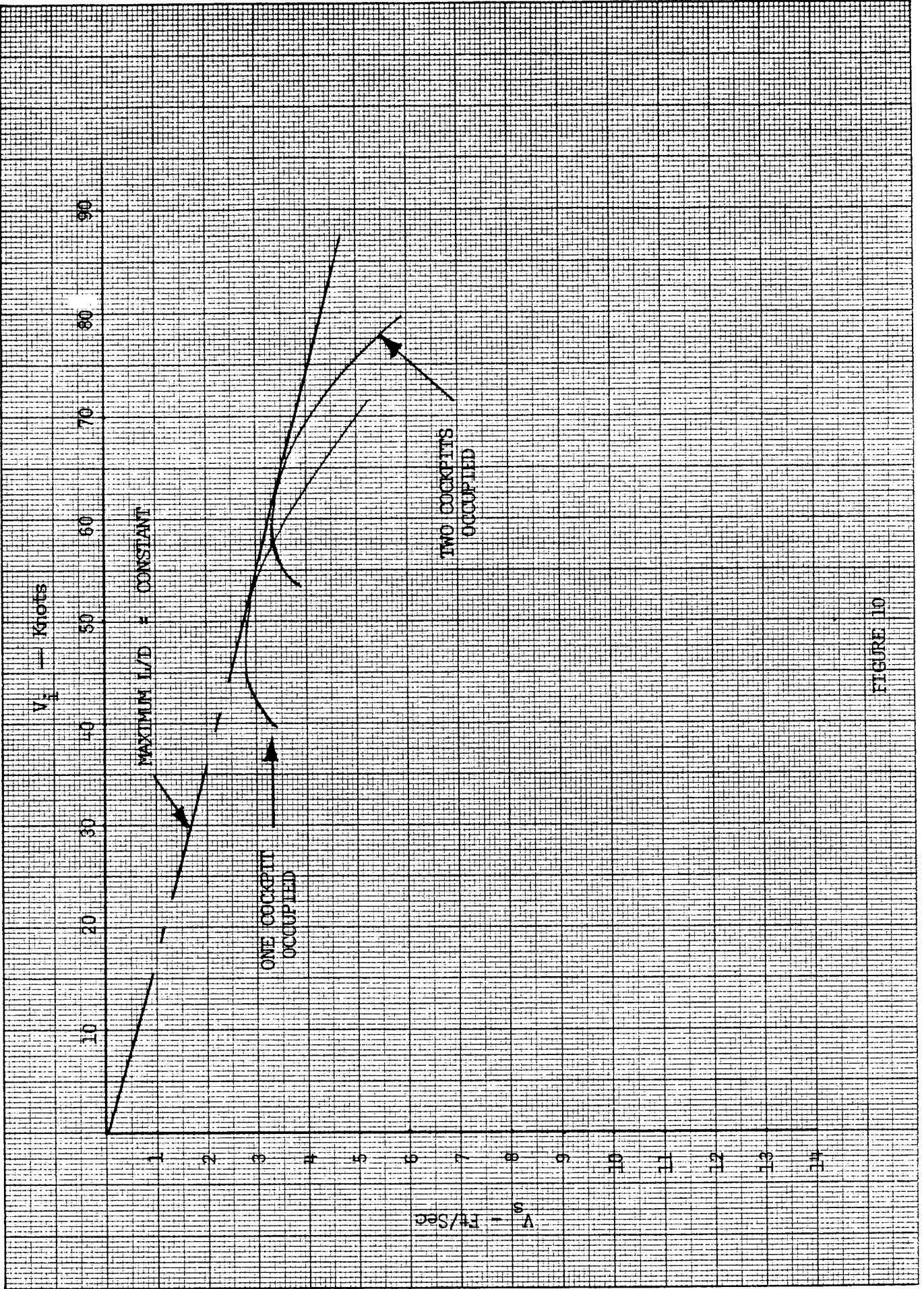
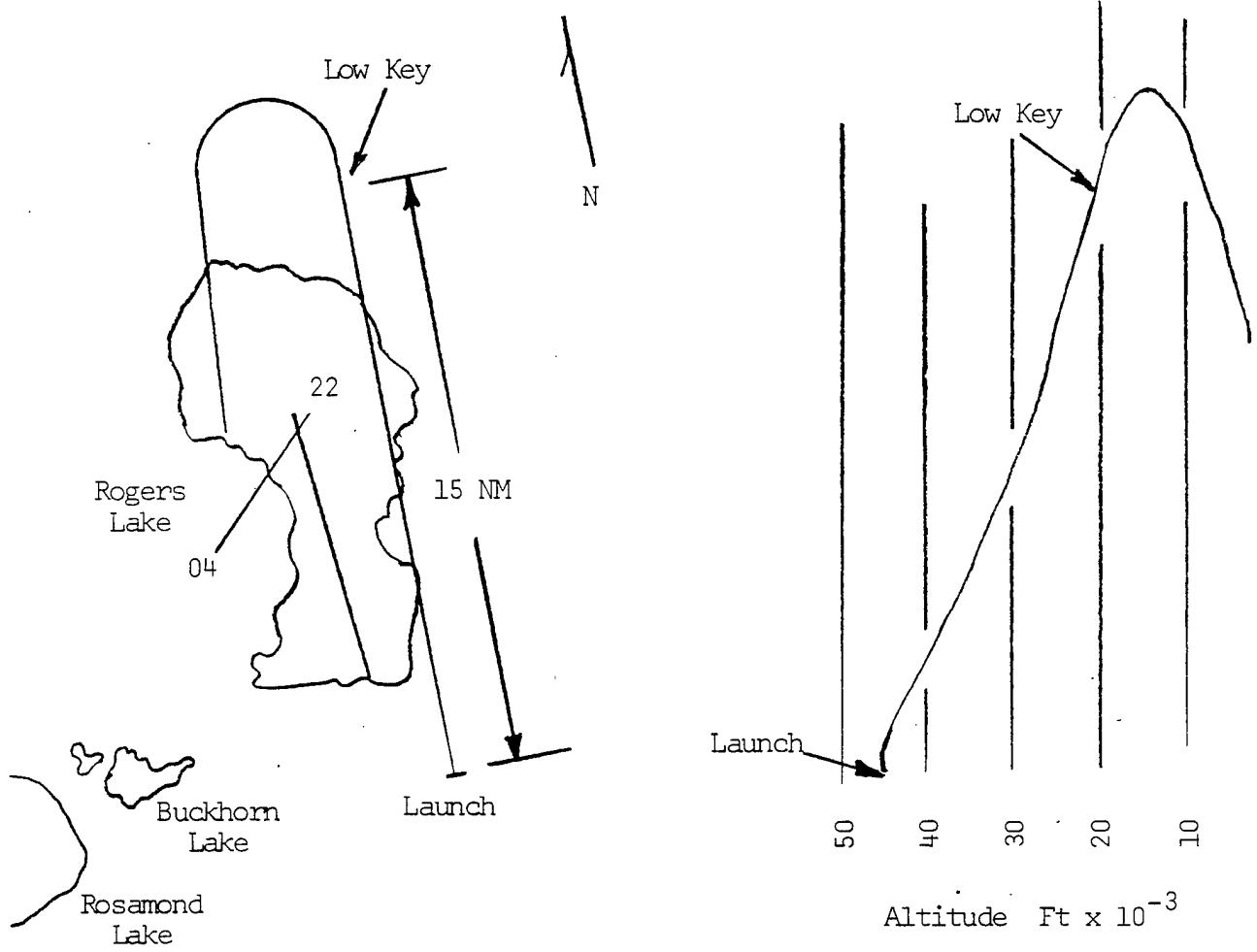

FIGURE 10

The X-24B glide flight and powered flight profiles are depicted in Figures 11 and 12. Simulation with the T-38 is accomplished from 30,000 feet down, which is in general where the X-24B is placed in the subsonic configuration. Simulation of that portion of a glide flight profile is very straightforward as the X-24B normal pattern for a glide flight profile is highly predictable. Simulation of powered flight, normal and abort profiles is less straightforward because a "normal pattern" does not exist because of the impossibility of predicting when an abort will occur, or of guaranteeing descent exactly on profile after a complete engine burn.

An oblique view of the normal X-24B landing approach is depicted in Figure 13. This is also the profile flown for simulation of a glide flight or the landing pattern portion of a powered flight. In general, the primary landing runway for the X-24B is lakebed runway 18. Flights are planned to other runways only when dictated by poor lakebed conditions after rain or snow.

Five to seven simulated approaches can be flown during a T-38 simulation mission. The number depends on the pattern entry altitude, the use of an efficient climb schedule, and whether climb is made with military power or afterburner. The approaches are controlled by Edwards tower on the normal tower UHF frequency (318.1), and the ground tracks are monitored by Edwards approach control using Mode 3 Code 4000 as an identifying IFF/SIF squawk. After takeoff, normal check-in and identification is made with approach control. Edwards approach control then releases the aircraft back to Edwards tower, and no further UHF contact is made with approach control.



X-24B GLIDE FLIGHT PROFILE

FIGURE 11

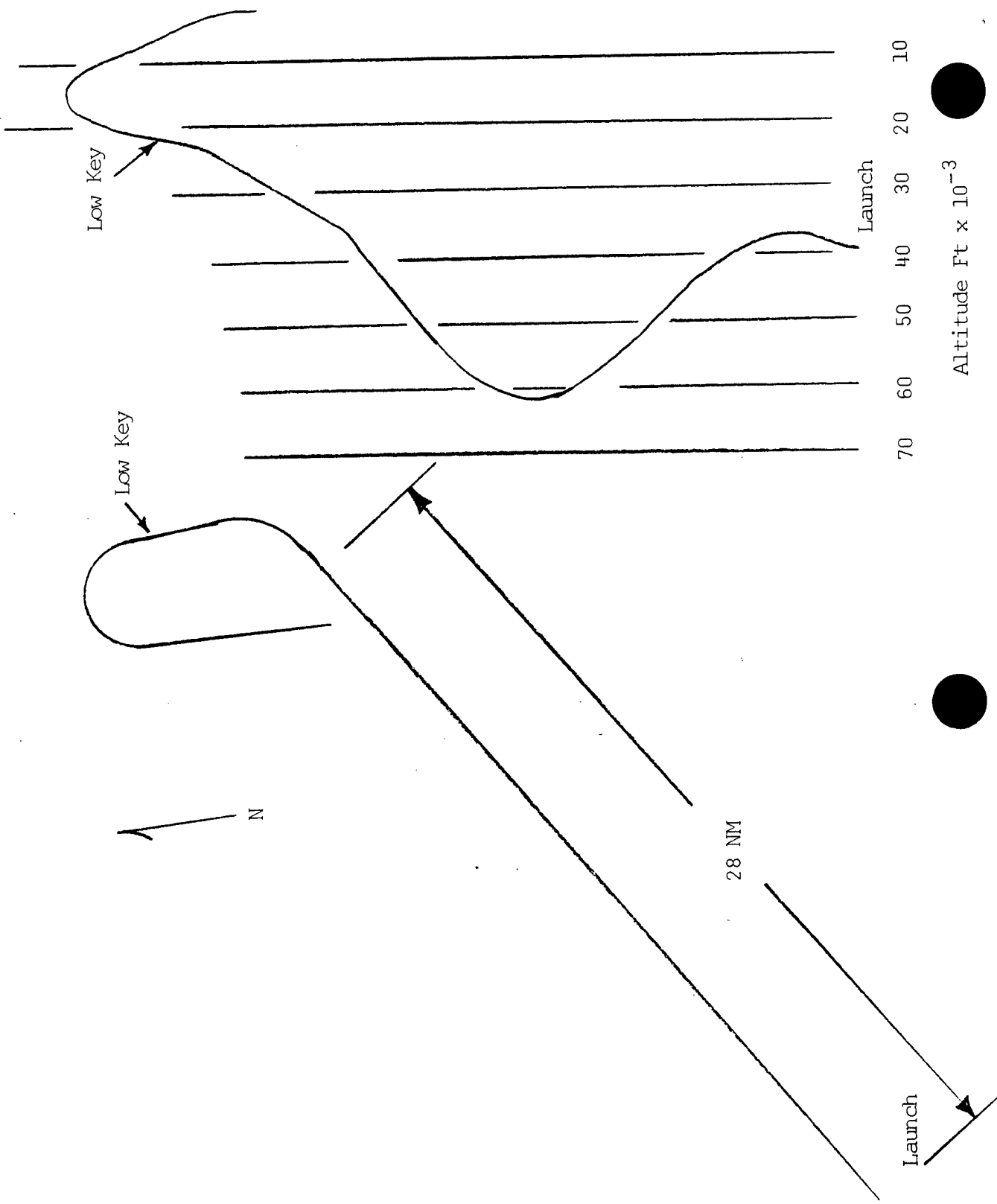

X-24B POWERED FLIGHT PROFILE

FIGURE 12

X-24B LANDING APPROACH PROFILE
 AND AIRBORNE SIMULATOR PROFILE
 RUNWAY ELEVATION 2,300 FT

Pattern Entry -
 Set Configuration and
 RPM for 220 KIAS Glide
 to Low Key

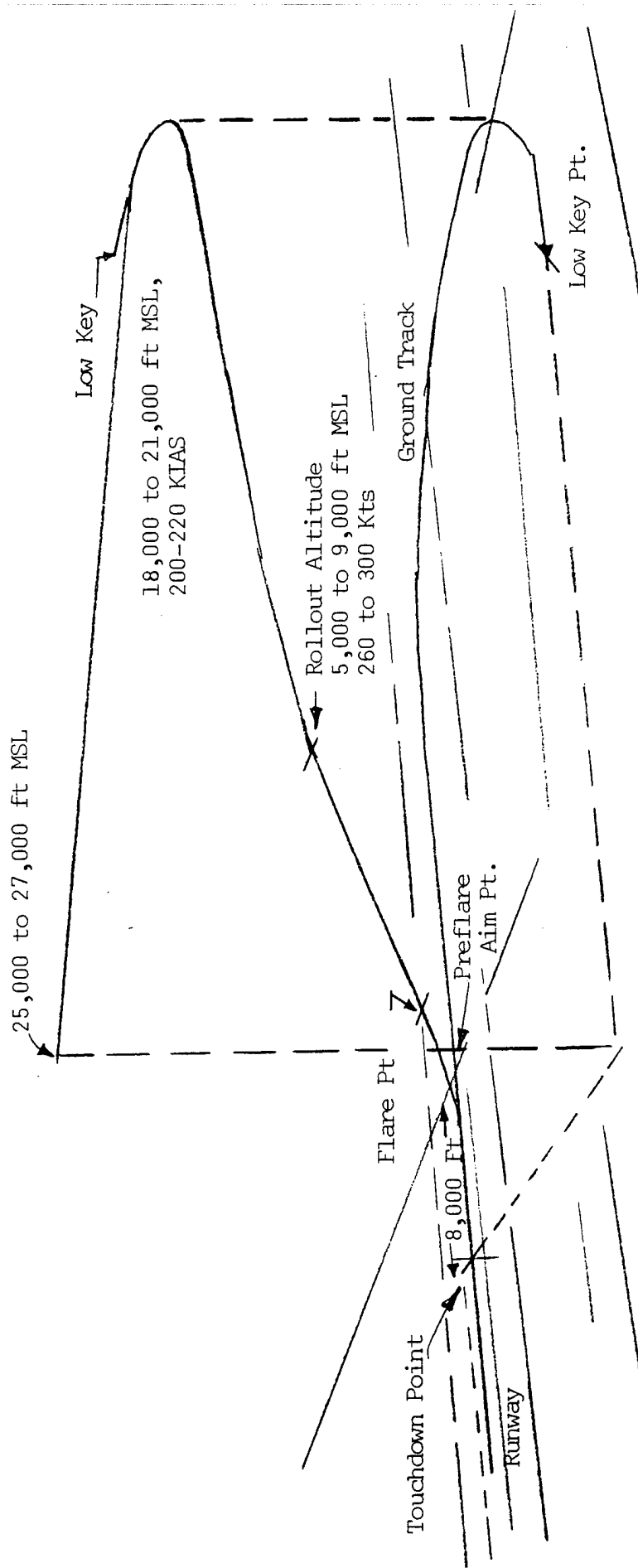

FIGURE 13

An efficient climb schedule for the T-38 in military power consists of climbing at 350 KIAS to 0.65 indicated Mach number. A climb to 10,000 to 12,000 feet on a westerly heading and then reversing to an easterly heading works well for putting the aircraft at the pattern entry altitude at the right conditions to configure for the approach. An airspeed bleed rate should be used through the last two or three thousand feet to reduce the airspeed to 200 - 220 KIAS, rolling out wings level on the reciprocal of the runway heading. Gear and speed brakes are then lowered, and the RPM is set to correspond with the fuel weight, interpolating as necessary from Figure 3. This entry point is 25,000 - 27,000 feet above mean sea level (MSL), displaced laterally from the touchdown point approximately 3.5 nautical miles. Glide to the low key point is then made at 210 KIAS.

The low key point is 18,000 - 21,000 feet MSL at 200 - 220 KIAS and heading 360 degrees. It is still 3.5 nautical miles abeam the landing runway with the preflare aim point back at 7 to 8 o'clock from the aircraft for a left hand pattern. At low key a 30 to 40 degree banked descending turn is initiated, allowing the airspeed to increase to approximately 250 KIAS by the 90 degree point where the altitude should be 15,000 to 17,000 feet and the ground distance from the touchdown point is approximately six nautical miles.

Airspeed is allowed to increase from the 90 degree point and roll out onto final approach is adjusted to arrive at a keyhole at 260 KIAS to

300 KIAS and 5,000 to 9,000 feet MSL, aimed at the preflare aim point. Final approach is then a constant, wings level glide with a flight path angle (γ) of about -18° . On a 300 knot approach, flare is initiated at 3,400 feet MSL by starting a gentle pitch rate which will arrest the sink rate by 200 to 100 feet above ground level (AGL). Load factor at flare initiation is only 1.5 to 2.0 "g". As the flare is initiated the throttles are slowly brought to idle so that most of the flare to touchdown is flown at idle thrust. Airspeed decrease during the period when the sink rate is being arrested is about 30 knots. A slight sink rate is then maintained as the airspeed bleeds from 270 to 240 knots, and the gear down point is reached at approximately 50 feet AGL. The aircraft is then descended so as to be below 20 feet by 220 knots and 5 feet by 190 knots. Touchdown in the X-24B is made between 190 and 170 knots, but in the T-38 touchdown speed is best kept below 180 knots because of the tire limit speed of 195 knots. On a 60°F day, touchdown at 188 KIAS results in a true speed of 195 knots, and on a 100°F day this indicated speed is reduced to 180 knots. Touchdown below 160 KIAS in the T-38 with no flaps and the throttles at idle is slightly uncomfortable because of the developing buffet. The T-38 pitch attitude at touchdown, or during the last portion of the flare from 220 KIAS, is much flatter than the X-24B, if touchdown is made at 180 KIAS. At 160 KIAS, the T-38 begins to show a marked nose rotation, but aircraft control is deteriorating. This is especially true if the final few feet of flare have been misjudged and a higher pitch rate is being initiated to arrest a building sink rate. Therefore, touchdown in the T-38 should be made

between 180 and 160 KIAS, but preferably between 180 and 170 KIAS. The nose gear cannot be held off after touchdown in the X-24B, but should be held off in the T-38 to minimize the possibility of foreign object damage (FOD) to the engines. Also, the number of touchdowns on the lakebed should be minimized because of the greater possibility of FOD, and also, because of the requirement to preserve the lakebed surface. Desired touchdown point on runway 04/22 is 10,000 feet remaining. Go around should be initiated if touchdown has not occurred by the center taxiway. The maximum comfortable crosswind acceptable for T-38 touch and go landings from these approaches is 10 knots. Also, the T-38 is uncomfortable in turbulence and gusting wind conditions because of its tendency to upset laterally. Descent below 10 feet is not recommended during gusting wind conditions and turbulence. On any low approach the throttles should be advanced and speed brakes retracted at 190 knots. This allows a comfortable acceleration margin while still allowing a good estimation of where touchdown would have been.

Turn out from lakebed runway 18 should be made to the right, turning and climbing so as not to disturb the people working on contractor's row or at NASA. Other traffic patterns which must be considered during the lakebed 18 approach or departure are the patterns for runways 24/06 at North Base, the tower flyby pattern, and the drop zone. Pattern calls consist of one minute to low key to runway 18, low key runway 18 with

gear checked, and on the go from runway 18 with intentions. The call at one minute to low key is made at the time the aircraft is configured for the approach. Calls for runway 22/04 are the same. In general, patterns to the main runway should be made from the northwest side because of the bombing range and alpha corridor. That is, a right hand pattern is flown to runway 22 and a left hand pattern to runway 04.

The ultimate objective of a power off approach is to make a safe landing reasonably close to the desired touchdown point. Reaching that point is an iterative combination of a number of factors. Probably the first step is to determine the desired touchdown speed. This speed is dictated by the margin of aircraft control in all three axes: longitudinal, lateral and directional. Touchdown speeds below a safe control speed are unacceptable, of course. The desired touchdown speed is also a function of aircraft geometry. An aircraft may be highly controllable below an airspeed at which the aft section is dangerously close to dragging (YF-16). In some cases, this may present a ground control problem. For example, in the case of the YF-16 a minimum touchdown speed of 135 KIAS is dictated by geometry, but at that speed the aircraft still has good flying speed. This means that positive control after touchdown is reduced for a period, especially in gusting crosswinds, because the aircraft remains very light on its gear until 115 KIAS. Another constraint on touchdown speed is the tire limit speed. The X-24B uses T-38 main gear tires which intentionally have been shaved to the first cord to allow touchdown at true speeds in excess of 195 knots. High main gear loads may

dictate a relatively high touchdown speed in order to increase control over the sink rate at touchdown. That is, if a high sink rate at touchdown would be a disaster then touchdown should be made at a speed where longitudinal control authority and stability and incremental lift available are adequate to arrest that level of sink rate (F-104).

After determining the touchdown speed, the final approach speed should be determined. The final approach speed is also a function of several considerations. The minimum final approach speed may be dictated by the ability to flare, or by the ability to accurately fly to the pre-flare aim point and touchdown near the desired touchdown point. The "dirty L/D" flown by the Test Pilot School in the F-104 was an approach where minimum flare airspeed was very important (Figure 14). This approach was flown with gear down, takeoff flaps, speed brakes out and 80% RPM at 295 KIAS. This resulted in a flight path angle of -29 degrees, and a sink rate on final in excess of 22,000 FPM. In this configuration 280 KIAS was considered the minimum safe airspeed to attempt a flare. At airspeeds below 280 knots, sufficient angle of attack could not be safely attained to arrest the sink rate because of the F-104 longitudinal instability above 15 degrees angle of attack (pitch up). The opposite problem occurs when flare capability is not in question, but the aircraft is flown too close to its maximum L/D capability (assuming an L/D available of four or more). In this case, touchdown accuracy deteriorates because it becomes more difficult to account for winds and errors made earlier in the pattern, prior to reaching final. In a way, it is similar to dive

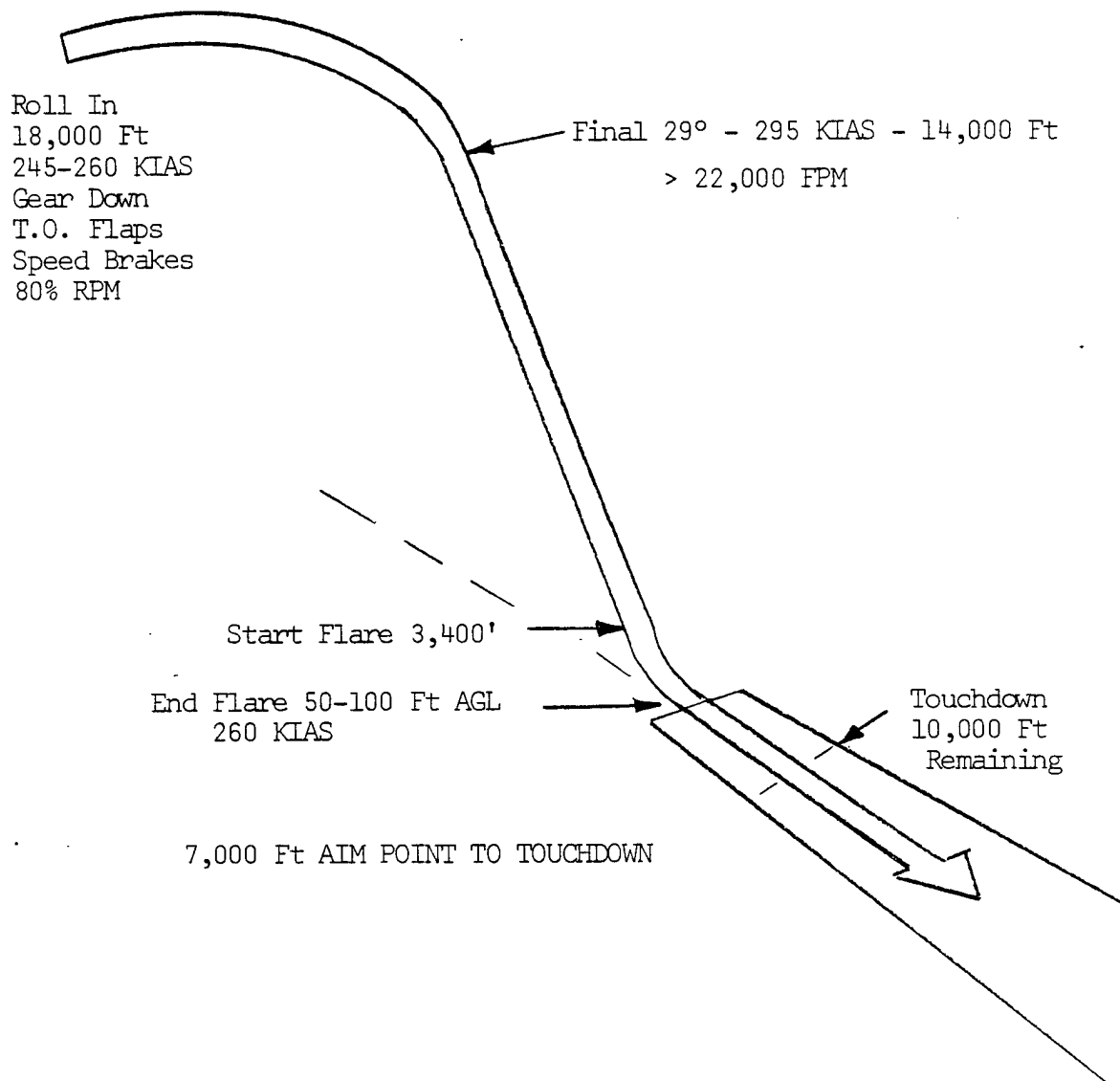

USAF TEST PILOT SCHOOL

DIRTY L/D - F-104

FIGURE 14

bombing where the longer the time of flight of the bomb, the larger are the impact errors. For a given length final approach, the shorter time on final will yield the better touchdown accuracy.

The maximum final approach speed is often dictated by some aircraft structural limit. In the "dirty" approach at the Test Pilot School, 295 KIAS was considered maximum because that was the Flight Manual gear limit speed with the gear extended, and no attempt was made to obtain clearance for a higher limit. When the T-38 was chosen to simulate the X-24B, it was necessary to obtain engineering and safety clearance to extend the gear down airspeed limit from 240 to 300 KIAS. In the case of the X-24B, maximum final approach airspeed is approximately 325 KIAS because of the aircraft calibrated airspeed limit of 330 knots.

The distance and time from flare to touchdown can also define a maximum final approach airspeed because an extremely long time can adversely affect touchdown accuracy. An example of such an approach was the 500 KIAS "Clean L/D" flown at the Test Pilot School in the F-104 (Figure 15). This approach was flown at idle RPM with gear and flaps up and speed brakes out. Dive angle was approximately 38 degrees with a rate of descent around 29,000 FPM. In this case, the preflare aim point could be maintained precisely, but it was difficult to determine the exact location of the correct aim point because it was 24,000 feet

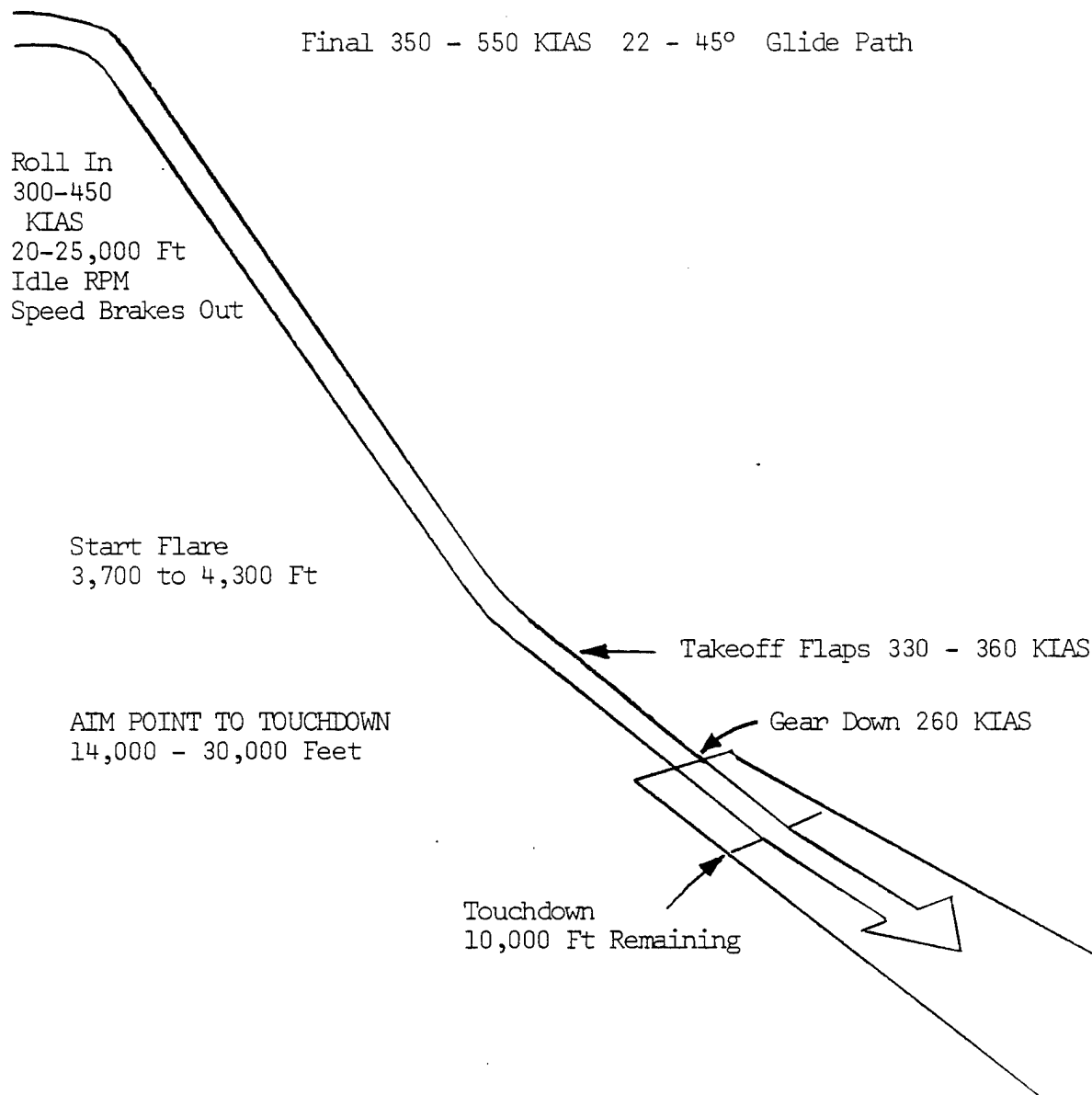

USAF TEST PILOT SCHOOL

CLEAN L/D - F-104

FIGURE 15

from touchdown and the time of flight from flare initiation to touchdown was excessive. This long distance and time also made it difficult to establish the shallow glide slope after the flare during which the takeoff flaps were lowered at 330 KIAS and the gear at 260 KIAS. There was a marked tendency to get too low too soon and be forced to level off at 20 to 30 feet while waiting to lower the gear at 260 KIAS. Another bad feature of the approach was the requirement for very flat terrain prior to the gear down point. It was a comfortable approach to runway 22, but was uncomfortable to lakebed runway 18 or runway 04 because of the desert terrain prior to the gear down point.

The actual aim final approach airspeed should be roughly midway between the minimum and the maximum airspeeds, and should allow about a 10% variance either way. This 10% adjustment factor allows for airspeed changes caused by gusts or wind shears, and it also makes it possible to make fine adjustments to the glide slope in order to maintain a constant preflare aim point. An example of a poor arrangement in this regard was the "dirty L/D" in the F-104. As discussed previously, it was very important to hold 295 KIAS. And, although maximum wind limits were 10 knots with gusts less than 5 knots, it was not uncommon to encounter 10 knot changes in airspeed caused by wind shears on final. This meant that the landing gear were routinely flown past their airspeed limit, or worse yet, when the airspeed suddenly decreased 10 knots, it meant that

an immediate nose down correction was necessary to preserve the ability to flare. Another bad aspect of being committed to 295 KIAS on the "dirty" was that no glide slope correction was possible. Thus, it was not possible to correct to the desired aim point in order to make a correction to the touchdown point. The "dirty" was an approach flown from the 90 degree point, which meant that the accuracy of the entire approach was determined during the roll in from that point to final. After that, no correction was possible because of the F-104 limitations which gave essentially no latitude for airspeed variance from 295 KIAS. The X-24B, by comparison, gives excellent latitude in varying the final approach airspeed. If 290 KIAS were considered the nominal final approach speed for the X-24B, it would have a comfortable 30 knot buffer either side of that speed to absorb gusts or allow glide path control. This is a very desirable characteristic.

The final approach airspeed, then, is largely dependent on the aircraft handling and performance characteristics during the flare, which is that time from the start of pullout to touchdown. Final approach is flown at a constant, low angle of attack, which means that airspeed is high relative to touchdown speed. The X-24B angle of attack on final is 5 degrees. At flare initiation, angle of attack is raised to another fairly constant value. This increases the load factor and causes a pitch rate as the sink rate is arrested. The sink rate is arrested by 100 to 200 feet AGL where another constant glide path is established to touchdown.

The flare initiation altitude is established by determining the altitude required to arrest the sink rate using a comfortable pitch rate and increase in load factor. Or, in other words, using only a moderate increase in angle of attack. For the X-24B flare, angle of attack is increased from 5 degrees on final to 8 degrees during the initial stage of the flare where the rate of sink is arrested. This takes about 1,000 feet of altitude for that aircraft and bleeds off about 30 knots of airspeed at a load factor of around 1.7 "g". However, in general, the flare is not flown with reference to these parameters. Altitude is cross-checked to start the flare, and then the pilot simply rotates the aircraft at a rate which will arrest the descent at the desired altitude above the ground.

The final glide path is shallow, about 3 degrees, with angle of attack and pitch attitude slowly increasing as the airspeed bleeds off to the touchdown. It is during this time that the final landing configuration is established, unless it is an aircraft which is configured prior to, or at, pattern entry (F-15, YF-16, F-4, T-33, etc.). If the landing gear are to be extended during the final glide, gear extension time and pitching moment changes are important considerations. The X-24A had an adverse nose down pitching moment as the gear extended. In the X-24B, this deficiency was corrected by reversing the direction of nose gear travel, such that the X-24B has almost no transient response during gear extension. The space shuttle gear will also be extended during this portion of the flare. Because of the large mass of its landing gear, it

is expected that the extension time will be a minimum of 6 to 10 seconds (compared with 1 second for the X-24B). This long extension time will have a bearing on how much airspeed will be required at the start of the 3-degree final glide path.

Other considerations during the final flare and touchdown are the airspeed bleed rate, the ability to adjust the final sink rate, the changes in aircraft stability after gear extension or as the angle of attack increases, and visibility. All these items contribute to the ease or difficulty in controlling the final touchdown. If the airspeed bleed rate is too high, the adjustment of the touchdown sink rate will be possible on only one attempt. That is, the sink rate can only be arrested on the first attempt to touchdown. After the first attempt, any rotation to higher angle of attack will only increase the sink rate because of the large airspeed loss during the first rotation. This means that the aircraft must be landed perfectly on the first rotation after entering the 3-degree glide slope. On the other hand, if the airspeed bleed rate is too low, a long flat flare covering excessive distance will result. Landing from the 3-degree glide path is a tracking task very similar to strafing. It must be possible for the pilot to approach the correct pitch attitude and bring the sink rate to zero during the one to two seconds that the touchdown airspeed is correct. A loss of aircraft response to pilot inputs during this time can be disconcerting. For example, the X-24B lower flap comes completely closed during a touchdown

at 180 KIAS with a sink rate less than 2 feet per second. This means that for several seconds that the only inputs made to the aircraft are made from the stability augmentation system. Fortunately, the basic stability of the X-24B at this time is very good, and all touchdowns to date have been very smooth and controlled. Finally, it is obvious that control of the touchdown will be lost if the pilot loses visual contact with the runway during the last crucial seconds. Cockpit design should be such that the pilot can see over the nose at an increment of angle of attack above that for normal touchdown.

The entry to final sets the minimum low key altitude and airspeed. From this minimum a comfortable normal altitude and airspeed for low key is established. In the case of the lifting bodies, data requirements tend to set a maximum on these two parameters in order to provide more time for data acquisition. In the case of a flameout approach for a fighter, the minimum pattern entry is generally emphasized because of the uncertainty about the glide distance required from flameout to pattern entry.

Another consideration which can dictate a minimum time for the glide or pattern is battery life or other emergency power source for the hydraulic systems.

The important concept in flying the pattern or gliding to the pattern is to understand the options for L/D control. These are the use of a

drag device to dissipate energy, the variation of airspeed toward or away from the speed for best L/D, and, of course, the variation in ground track towards or away from the pattern or the final approach. A good general rule, where possible, is to plan the approach so that extra altitude must be dissipated. This is because it is much easier to dissipate extra energy than it is to conserve minimum energy. The X-24B approach described in these notes has a good pad of energy planned into the pattern. On every approach flown in the X-24B to date, the flaps have been used somewhere past low key to get rid of the extra altitude planned into the approach. This extra altitude could also be dissipated by lowering the nose early to increase the airspeed and lower the L/D. Or, if the L/D is maintained high, the energy can be dissipated by increasing the ground track and flying a larger pattern. This is the least acceptable method, however, because as the pattern size is increased touchdown accuracy is decreased. If the pattern is entered with very low energy at low key (15,000 feet), then there is no choice but to fly at or near maximum L/D in order to reach final approach with enough altitude to push-over and accelerate to an acceptable flare airspeed. In the X-24B simulations using the T-38, this minimum altitude appears to be 6,200 feet to provide a flare airspeed of 260 KIAS after a push-over from 210 KIAS. The push-over and flare are uncomfortable at best, and this sort of poor planning is certainly best avoided. However, with a surprise flameout in a fighter (YF-16, etc.), the situation may very well develop. The point to remember, then, is that you must have enough altitude to attain flare airspeed for your aircraft. If you don't have that, then ejection is

probably the most acceptable alternative. A pattern entered with enough altitude to require some energy dissipation is the most comfortable and the most accurate in terms of touchdown control.

These notes have covered the considerations for choosing a simulator aircraft for power off approaches of a test aircraft. The focus has been on the X-24B program, but considerations involving other aircraft have been mentioned as applicable. At least one curriculum mission devoted to L/D approaches would be a meaningful part of the TPS curriculum. This mission should be flown in the T-38 and encompass five or six X-24B approaches to lakebed runway 18 with low approaches, or to runway 22/04 with touch and go's from the 10,000 foot remaining marker. In order to broaden the spectrum of exposure, L/D approaches should be worked into other curriculum missions as additions to existing mission cards. For example, simulated flameout approaches are already flown in the T-33. The T-33 or F-4 are good simulators of the YF-16, and the patterns and RPM settings could be obtained from the Lightweight Fighter Joint Test Force and refined for School use. The B-52 is also an impressive airplane in an L/D approach, and it would probably be a very good idea to work one L/D into each qualitative evaluation. The combination of good L/D notes and a minimum of flying exposure to the L/D problem should help the TPS graduate formulate a satisfactory training program for power off approaches, should he be confronted with this requirement at some future date after graduation.