

ARMY RESEARCH LABORATORY



Inadvertent Activation of Controls Literature Search

Patricia M. Burcham

ARL-MR-337

OCTOBER 1996

19970124 058

DTIC QUALITY INSPECTED 3

The findings in this report are not to be construed as an official Department of the Army position unless so designated by other authorized documents.

Citation of manufacturer's or trade names does not constitute an official endorsement or approval of the use thereof.

Destroy this report when it is no longer needed. Do not return it to the originator.

Army Research Laboratory

Aberdeen Proving Ground, MD 21005-5425

ARL-MR-337

October 1996

Inadvertent Activation of Controls Literature Search

Patricia M. Burcham
Human Research & Engineering Directorate

DTIC QUALITY INSPECTED 6

Approved for public release; distribution is unlimited.

Abstract

A literature and military documentation search was conducted to identify typical human factors engineering (HFE) design considerations to minimize inadvertent activation of controls. This report discusses findings of the search.

CONTENTS

BACKGROUND	3
FINDINGS	3
MIL-STD-1472D	3
Van Cott and Kinkade, 1972	4
Salvendy, 1987	5
Helander, 1981	7
McCormick, 1970	11
NASA-STD-3000, July 1995	13
RECOMMENDATIONS AND CONCLUSIONS	15
REFERENCES	17
APPENDIX	
A. Figures	19
DISTRIBUTION LIST	31
TABLES	
1. Control Movement Stereotypes	7
2. Recommended Controls for the Case When Both Force and Range of Settings are Important	10

INADVERTENT ACTIVATION OF CONTROLS LITERATURE SEARCH

BACKGROUND

An integrated product and process development (IPPD) effort at the Unmanned Ground Vehicle/Systems Joint Project Office (UGV/SJPO) identified a number of issues concerning existing tactical unmanned ground vehicles (TUGV) requirements and constraints. The Human Research & Engineering Directorate (HRED) of the U.S. Army Research Laboratory (ARL) was tasked to conduct a literature and military documentation search to identify soldier-machine interface design guidelines to minimize the probability of inadvertent activation of controls. Inadvertent control actuation may occur because of inadequate separation between controls, poor location, getting clothing or other material caught, usage of the control as a handhold or foothold, or misidentification because of inadequate labeling or coding. The following report includes results of the research effort to address Study No. TUV-013; TUGV issue 129 (see PM-UGV, 1995).

FINDINGS

MIL-STD-1472D (Department of Defense, 1989).

Paragraph 5.4.2.2.2.6 Inadvertent operation.

“When it is critical to prevent inadvertent activation of one knob as the other is being adjusted, a secondary knob control movement shall be required (e.g., pressing the top knob before it can be engaged with its control shaft). Where inadvertent movement is undesirable but not necessarily critical, knob diameter/depth relationships should be optimized as shown in Appendix A, Figure A-1. Contrasting colors between knobs may also be used to improve individual knob identification.”

Note. This paragraph was also presented in MIL-HDBK-759B, paragraph 5.2.1.6.10.6 (Department of Defense, 1992).

Paragraph 5.4.3.1.8.5 Snagging and inadvertent contact.

“Use, location and operating axis of push-pull type controls shall preclude the possibility of operator's:

- a. Bumping a control while getting into or out of position (as in a vehicle).

b. Snagging clothing, communication cables, or other equipment items on the control.

c. Inadvertently deactuating the control setting while reaching for another control.”

Van Cott and Kinkade, 1972

Paragraph 8.2.5 Preventing Accidental Activation

It is always desirable to reduce the possibility of accidentally activating controls. However, in the application of any of the various methods of physically protecting controls against inadvertent activation, it is necessary to consider the extent to which other human engineering design criteria are compromised. For example, protection against accidental activation is so serious that it is mandatory to design the control assembly to eliminate the possibility.

Methods of physically protecting controls against inadvertent activation include

a. Recessing. Controls can be recessed so that they do not protrude above the control panel surface. A related technique is to place raised barriers around the control. A disadvantage of this method is the amount of panel space that must be used.

b. Location. Controls can be located so that they are unlikely to be hit accidentally. This can be accomplished by isolating one control from others and by arranging controls so that the sequence of operations is not conducive to accidental activation.

c. Orientation. The direction of movement of the control can be oriented along an axis in which accidental forces are least likely to occur, but care should be taken to ensure that recommended direction-of-motion relationships are not violated.

d. Covering. Protective covers or guards can be placed over the control. If the control is to be operated frequently, however, this method probably cannot be used or will be disabled.

e. Locking. Controls can be locked in position. This method generally requires the sequential application of force in at least two directions to release and operate the control. This method is undesirable, however, if the control is used frequently.

f. Operation sequencing. A series of interlocks can prevent Step 2 from being performed before Step 1, Step 3, or before Step 2, and so forth. There are two variations of this method. In the first, all the steps preceding the last one have a direct effect on system output (e.g., a bomb-release control that cannot be operated unless the control that arms the bomb has already been activated). This variation cannot, of course, be used when the sequence of operation differs from situation to situation. In the second variation, the steps preceding the last one have no direct effect on system output other than to permit the next control operation to be performed. In the simplest situation, a preliminary operation (e.g., pushing a button, squeezing a trigger) releases the control from its normal operation.

g. Resistance. Use of the proper kind or kinds and amount of resistance prevents accidental forces (e.g. below the breakout force) from activating the control.

Salvendy, 1987

Paragraph 5.3.8 Safety Requirements, pages 598-599

“Spurious actuation of a control may be caused by the operator, by unauthorized persons, or by surrounding influences such as mechanical vibrations or the falling down of objects. Inadvertent actuation of a control by the operator may be caused by slipping off of a control and actuating a neighboring control, because of inadequate distance between one control and the next, getting one’s clothes caught, and/or supporting oneself by holding onto a control. Inadvertent actuation of a control may also result from wrong operation by the operator, for example, due to unfavorable coding. The design principles discussed above should therefore also be seen in the light of safety aspects.

The marginal conditions of safety must be taken into consideration as early as in the definition of the design parameters. Shape and surface of the control must be designed so that slipping of a control is prevented, in order to avoid injury to the worker and spurious actuation. A push button may, for example, be provided with a concave top or with extra-fine profiles. If controls have to be mounted on rotating shafts, provision will have to be made for clutches, so that the transmission of power can be interrupted. For actuation, it will first be necessary to apply an axial force. If this cannot be realized, controls will have to be used, in which getting clothing caught is not possible; that is, disk handwheels with a closed stay must be used instead of cranks and spoked handwheels.

In the case of important controls, in which inadvertent actuation would endanger persons and the system, provision will have to be made for additional safeguards. Such undesirable actuation can be prevented or minimized by the following design measures, which are based on various cause-and-effect principles such as the interruption or complication of the flux of force.

- a. Covering of the control
- b. Recessing or shielding of the control
- c. Controls not to be arranged within the supporting and main movement area of arms and legs
- d. Direction of control movement is not identical to the direction of movement of the body or its extremities
- e. Making provision for large tripping forces
- f. Making provision for frictionally actuated instead of positively actuated controls (e.g., finger slide instead of push button)
- g. Detachable controls (controls must not be interchangeable)
- h. Two-dimensional control (one degree of freedom for unlocking), lockable control malfunctional control (one control for unlocking or for simultaneous operation (two-hand control, dead man's control))

Keys are to be regarded as special forms of controls that can be used for rotational actuating movements for two or several steps. By removal of the key, a high degree of safety is guaranteed against unauthorized and inadvertent operation. The design measures mentioned above will have to be supplemented by notices in the form of the various coding possibilities. It is obvious that safety measures in part do not satisfy the requirements of ergonomics. Covers and recessed controls, for example, prevent quick actuation of controls, large tripping forces place greater stresses and strains on the operator, and the movements of controls in directions other than the preferred anatomical directions do not permit any favorable transfer of forces. Thus it may be necessary to compromise, with due consideration of the priorities.”

Helander, 1981

Paragraph 6.6.3 Controls, pgs. 164-170

“People usually have expectations regarding how a control should be moved. For example, an electric switch is expected to turn the light on when moved upward. Expectations of this type are called ‘control movement stereotypes’, Table 1. Some of the more important stereotypes imply that any increase of controlled variable (such as speed, voltage, and rpm) should be initiated by a clockwise rotation for a rotary switch, or a movement downward for a pedal, or a movement upward or away from the body for a lever. The design of controls should use these preprogrammed inclinations because operators learn to use controls faster and make fewer errors when controls move in the expected ways.

Table 1
Control Movement Stereotypes

Function	Direction of movement
On	Up, right, forward, clockwise, pull (push-pull type switch)
Off	Down, left, rearward, counterclockwise, push
Right	Clockwise, right
Left	Counterclockwise, left
Raise	Up, back
Lower	Down, forward
Retract	Up, rearward, pull
Extend	Down, forward, push
Increase	Forward, up, right, clockwise
Decrease	Rearward, down, left, counterclockwise
Open valve	Counterclockwise
Close valve	Clockwise

If there are space constraints that make it necessary to position controls where an operator must locate them without seeing them, designers should consider the following error tendencies:

- a. When controls are above shoulder level, operators tend to reach too low.
- b. When controls are on either side of the operator, he tends to reach too far to the rear.
- c. When controls are placed below shoulder level, operators tend to reach too high.

It is important to keep these error tendencies in mind when designing control layouts so that the operator does not activate other critical controls by mistake.

Once the needed controls have been determined, it is important to code them so that they can easily be distinguished and are easy to operate without errors. Coding implies adding distinguishing features to the controls in one way or another. The designer may code by location, color, size, shape, labeling or mode of operation (or combinations of two or more of these features).

Coding by location is important. People seem to be very good at remembering where things are located on the space around them (e.g., it is easy to find a light switch in a familiar room, even in the dark). Coding by location provides the opportunity to arrange the controls in functional groups so that the controls located together are identical in function, used together in specific tasks, and/or related to one equipment or system component, for example, engine controls separated from boom controls.

When the operator uses several controls in sequence with the same hand, the controls should be arranged in horizontal rows from left to right, in order of operation. If the horizontal rows are impractical, the controls could be arranged in vertical rows from top to bottom.

The most important controls should be positioned where they are easily reached. The following factors determine importance:

- a. Frequency and duration of use.
- b. Accuracy and speed of operation required.
- c. Ease of manipulation in terms of force, precision, and speed.

The most important controls should be located at a height between the operator's waist and shoulder and within a radius of 16 inches from the normal working position. They should be grouped together, preferably to the right front of the operator (to be operated by the right hand). When this is not possible, they can also be positioned to the left front. Refer to Appendix A, Figure A-2 for optimum and maximum hand and foot control space.

Controls that are used less frequently and are less important should be located within 20 inches of the normal work position. Controls that are used infrequently may be placed to the side. These might be covered, mounted behind hinged doors, or recessed into the instrument panel to reduce distraction and prevent inadvertent operation.

Coding by color is an obvious way of making controls easy to distinguish. Color coding requires that the operator look at the controls. This may increase operator time. Therefore, color should not be used as the only coding technique. The number of colors that can be used is usually limited to the ones that are easy to name and refer to. The most commonly used are red, orange, yellow, green, and blue. Color coding is inadequate in dimly lit environments and color-coded equipment or controls cannot be used in underground or poorly illuminated areas.

Coding by size can make it easy to identify a control both by sight and by touch. Controls that are frequently used should be made larger than other controls. Size coding is frequently used for knobs on the ends of levers. Safe recognition of the sizes requires that the number of sizes used be limited to three. This is especially important for emergency situations, when people are more error prone.

Coding by shape greatly enhances the discriminability of the controls by touch alone. Ideally, the shape of the control should suggest the controlled function. Recognition by touch takes a fairly long time, so shape coding should not be primarily relied upon.

Labeling is an effective way of identifying controls, provided there is adequate illumination to read the labels. There are a few general recommendations for the design of labels.

- a. Black letters on white background are preferred unless the illumination level is below 1 footcandle (f.c.) or the eye is dark adapted, in which case, white letters on a black background are preferred.

b. Capital letters are preferred with a width-to-height ratio of 3:5 and a stroke width-to-height ratio of 1:6 to 1:8. Assuming a viewing distance of 28 inches, the letter height should be at least 0.20 inch. Lettering should always be horizontal.

c. The label should be placed on or beside the control. Only common words or abbreviations should be used. Abstract symbols should be avoided since they require special training.

Coding by control resistance or other control movement characteristics can help the operator in identifying controls (see Table 2). Resistance affects the precision and speed of the control, control feel, and smoothness of control movement, thereby reducing the susceptibility to accidental activation.

If the hand is used to manipulate the control, the resistance should be at least 2 lb (this does not apply to finger-operated controls). If the hand and entire arm are used, the minimum resistance should be 10 to 20 lb; for forearm and hand, 5 lb.”

Table 2

Recommended Controls for the Case When Both Force and Range of Settings are Important

Forces and settings	Control
<i>Small force settings</i>	
2 discrete	Pushbutton or toggle switch
3 discrete	Toggle switch or rotary selector switch
4 to 24 discrete	Rotary selector switch
Small range of continuous	Knob or lever settings
Large range of continuous	Crank or rotating knob settings
<i>Large force settings</i>	
2 discrete	Detent lever, large hand push button, or foot push button
3 to 24 discrete	Detent lever, rotary selector switch
Small range of continuous	Handwheel, rotary pedal, or lever
Large range of continuous	Large crank, handwheel settings

McCormick, 1970

Identification of Controls, pages 337-346

The identification of controls is essentially a coding problem. Coding methods include shape, texture, size, location, and operational method (see Appendix A, Figure A-3).

a. *Shape Coding*. The accuracy of control identification is the primary consideration in shape coding (Appendix A, Figure A-4). Tactual discrimination and symbolic association contribute to identification.

The U.S. Air Force developed 15 knob designs which are rarely confused with each other. There are three designs, each designed to serve a specific purpose:

Class A: *Multiple rotation*. "These knobs are for use on controls which require twirling or spinning, for which the adjustment range is one full turn or more, and for which the knob position is not a critical item of information in the control operation."

Class B: *Fractional rotation*. "These knobs are for use on controls which do not require spinning or twirling, for which the adjustment range usually is less than one full turn, and for which the knob position is not a critical item of information in control operation."

Class C: *Detent Positioning*. "These knobs are for use on discrete setting controls."

The 15 knobs are shown in Appendix A, Figure A-5. Some of the knobs were confused with each other; therefore, such combinations should not be used together if identification is critical. These combinations were ab, co, cd#, do#, eg#, kp, ln, lo, np, op#. Those denoted with a # sign were confused only while wearing gloves. It is suggested that the knobs be not more than 4 inches in their maximum dimension and not less than 1/2 inch (except for class C, for which a 3/4-inch minimum is suggested). They should not be less than 1/2 inch or more than 1 inch in height.

b. *Symbolic associations of controls*. The learning of control use can be simplified if in addition to being discriminable by touch, the controls have shapes associated with their use. Examples of standard knob shapes developed by the United States Air Force include a landing gear knob shaped like a landing wheel, a flap control shaped like a wing, and a fire extinguishing control shaped like a fire extinguisher handle as seen in Appendix A, Figure A-6.

c. *Texture coding of controls*. Control devices varied in their surface texture were studied in several experiments with flat cylindrical knobs. The conclusion was that three surfaces characteristics, namely, smooth, fluted, and knurled, can be used with reasonably accurate discrimination.

d. *Size coding of controls*. Size coding is not as useful as shape coding. The combination of textured surfaces, thickness, and diameters can be used to distinguish individual control devices. The differences in sizes of ganged, where two or more knobs are mounted on concentric shafts with various sizes superimposed on each other like layers of a wedding cake, need to be great enough to make them clearly distinguishable (see Appendix A, Figure A-7).

e. *Location coding of controls*. Location coding include shifting your foot from the accelerator to the brake pedal, feeling for the light switch at night, or blindly grasping for a machine control. A study by Fitts and Crannell revealed that accuracy was greatest when the toggle switches were arranged vertically. For vertically arranged control locations, a separation of at least 5 inches is desirable. For horizontally arranged controls, a minimum separation of 8 inches is preferred.

f. *Operational method of coding controls*. Each control has its own unique method for its operation. Each can only be activated by movement that is unique to it (e.g., one control may be a push-pull type while another may be a rotary type). This method of coding should be avoided except where it seems to be uniquely appropriate. This method would be inappropriate when there is any premium on time in the operation of a control or when operating errors are of considerable importance.

General principles include

(1) *Shape and texture*.

Desirable features: Useful with low illumination or when a control may be identified and operated by feel; can supplement visual identification; useful in standardizing controls for identification.

Undesirable features: Limited number of controls that can be identified (fewer for texture than for shape); glove usage reduces human discrimination.

(2) *Location*.

Desirable features: Same as those for shape and texture.

Undesirable features: Limited number of controls that can be identified; may increase space requirements; identification not as certain (may be desirable to combine with other coding scheme).

(3) *Color.*

Desirable features: Useful for visual identification; useful for standardization of controls; moderate number of coding categories possible.

Undesirable features: Must be directly viewed (however, can be combined with other coding methods); cannot be used under poor illumination; adequate color vision requirement.

(4) *Labels.*

Desirable features: Large number can be identified; little to no training required.

Undesirable features: Must be directly viewed; cannot be used under poor illumination; may require additional space.

(5) *Operational method.*

Desirable features: Often cannot be used incorrectly (control is usually operable in only one way); can capitalize on compatible relationships (but not necessarily).

Undesirable features: Must be tried before knowing whether correct control has been selected; specific design might have to incorporate incompatible relationships.

NASA-STD-3000, July 1995

Control Location

9.3.3.2 Accidental Actuation Design.

“Requirements for reducing accidental actuation of controls are presented below.

a. *Design and Location* - Controls shall be designed and located so as to minimize susceptibility to being moved accidentally. Particular attention shall be given to critical controls whose inadvertent operation might cause damage to equipment, injury to personnel, or degradation of system functions.

b. *Protective Methods* - Adequate protection shall be provided for controls that are susceptible to accidental actuation. Protective methods include but are not limited to those listed below.

(1) Locate and orient the controls so that the operator is not likely to strike or move them accidentally in the normal sequence of control movements.

(2) Recess, shield, or otherwise surround the controls by physical barriers. The control shall be entirely contained within the envelope described by the recess or barrier.

(3) Cover or guard the controls. Safety or lockwire shall not be used.

(4) If a cover guard is used, its location when open should not interfere with the operation of the protected device or adjacent controls.

(5) Provide the controls with interlocks so that extra movement (e.g., lifting switch out of a locked detent position) or the prior operation of a related or locking control is required.

(6) Provide the controls with resistance (i.e., viscous or coulomb friction, spring-loading, or inertia) so that definite or sustained effort is required for actuation.

(7) Provide the controls with a lock to prevent the control from passing through a position without delay when strict sequential actuation is necessary (i.e., the control moved only to the next position, then delayed).

c. *Noninterference* - Protection devices shall not interfere with the normal operation of controls or the reading associated displays.

d. *High Traffic Areas* - Critical controls shall not be located in high traffic paths or translation paths. If controls must be placed in these locations, means shall be used to prevent inadvertent actuation (i.e., pull to unlatch toggle switches).

e. *Dead-Man Controls* - When appropriate, controls that result in system shutdown to a noncritical operating state when force is removed shall be used when operator incapacity can produce a critical system condition.

f. *Barrier Guards*:

(1) Barrier guard spacing requirements for use with toggle switches, rotary switches, and thumbwheels are shown in Appendix A, Figures A-8 and A-9.

(2) Accidental actuation of controls can result when crew members use barrier guards as handholds. Barrier guards shall be designed and located so as to minimize this problem.

g. *Recessed Switch Protection* - During conditions when barrier guards are not applicable, rotary switches that control critical experiment or vehicle functions shall be recessed as shown in Appendix A, Figure A-8.

h. *Detachment* - Covers and guards shall be designed to prevent accidental detachment during operational periods.

i. *Position Indication* - When protective covers are used, control position shall be evident without requiring cover removal.

j. *Hidden Controls* - When hidden controls (i.e., controls that can not be directly viewed) are required they shall be guarded to prevent inadvertent actuation.

k. *Hand Controllers* - Hand controllers shall have a separate on/off control to prevent inadvertent actuation when the controller is not in use.

l. *Circuit Breaker Protection* - When circuit breakers are ganged in a common array, a cover shall be used as an additional security measure to prevent inadvertent actuation or damage."

RECOMMENDATIONS AND CONCLUSIONS

The design guidelines obtained from the references discussed in this report were somewhat redundant; however, each reference provided varying design approaches with relation to their respective dependence on existing conditions. MIL-STD-1472D and MIL-HDBK-759B

were limited in guidelines specifically related to inadvertent activation of controls while NASA-STD-3000 provided detailed alternatives. Although dated, the most comprehensive information was revealed in Helander, 1981, and McCormick, 1970.

Helander discusses the importance of recognizing control stereotypes, related error tendencies, and the importance of appropriate coding and location of controls. Environmental conditions such as illumination, ambient temperature, and vibration must be taken into consideration when determining the best alternative for each situation.

McCormick also places emphasis on coding techniques in proper control identification. More specifically, tactual discrimination and symbolic association are discussed.

Some of the safeguards to consider for minimizing susceptibility of inadvertent control activation include adequate separation between controls (e.g., bare or gloved hand), barrier guards, recessed switches, covers, interlocks, operation sequencing, and location. When weighing these options, it is important to consider the extent to which human engineering design criteria may be compromised. Cause and effect of coding techniques should be thoroughly reviewed during the design process.

REFERENCES

- Bradley, J.V., & Stump, N.E. (December 1955). Minimum allowable dimensions for controls mounted on concentric shafts (TR 55-355). USAF, WADC.
- Department of Defense (14 March 1989). Human engineering design criteria for military systems, equipment, and facilities (MIL-STD-1472D, pp. 84, 101). Washington, DC: Author.
- Department of Defense (30 June 1992). Human factors engineering design for army materiel (MIL-HDBK-759B[MI], pp. 45). Washington, DC: Author.
- Helander, M. (ed.) (1981). Human factors/ergonomics for building and construction, pp. 164-170 John Wiley & Sons.
- Hunt, D.P. (August 1953). The coding of aircraft controls (TR 53-221). USAF, WADC.
- Jenkins, W.O. (1947). The tactual discrimination of shapes for coding aircraft-type controls, in P.M. Fitts (ed.), Psychological research on equipment design, (Research Report 19). Army Air Force, Aviation Psychology Program.
- McCormick, E.J. (1970). Human factors engineering. McGraw-Hill Book Company, pp. 338-343.
- NASA (July 1995). Man-Systems integration standards, Volume II, Revision B, pp. (9-26) - (9-27). (NASA-STD-3000).
- PM-UGV (2 Oct 1995). TUGV issues list database, HRED issues. Aberdeen Proving Ground, MD: Author.
- Salvendy, G. (ed.) (1987). Handbook of human factors, pp. 598-599. John Wiley & Sons, Inc.
- Van Cott, H.P., & Kinkade, R.G. (eds.) (1972). Human engineering guide to equipment design. McGraw-Hill Company.

APPENDIX A

FIGURES

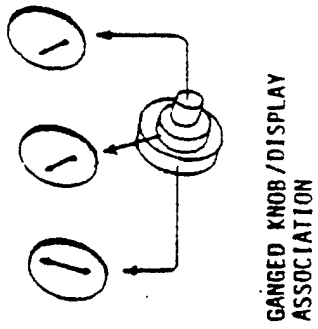

GANGED KNOB/DISPLAY ASSOCIATION

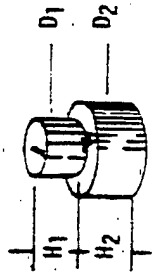
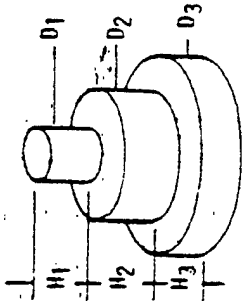

DIMENSIONS

		TWO KNOB ASSEMBLY			THREE KNOB ASSEMBLY						
		H ₁	H ₂	D ₁	D ₂	H ₁	H ₂	H ₃	D ₁	D ₂	D ₃
MINIMUM		16 mm (5/8")	13 mm (1/2")	13 mm (1/2")	22 mm (7/8")	19 mm (3/4")	19 mm (3/4")	6 mm (1/4")	13 mm (1/2")	44 mm (1-3/4")	75 mm (3")
MAXIMUM					100 mm (4")						100 mm (4")

TORQUE

		TORQUE		SEPARATION			
		*	**	ONE HAND INDIVIDUALLY		TWO HANDS SIMULTANEOUSLY	
				BARE	GLOVED	BARE	GLOVED
MINIMUM				25 mm (1")	63 mm (2-1/2")	50 mm (2")	90 mm (3-1/2")
OPTIMUM				50 mm (2")	90 mm (3-1/2")	75 mm (3")	100 mm (4")
MAXIMUM		32 mN·m (4-1/2 in.-oz.)	42 mN·m (6 in.-oz.)				

*To and including 25 mm (1") diameter knobs.
 **Greater than 25 mm (1") diameter knobs.

Figure A-1. Ganged knobs (MIL-STD-1472D).

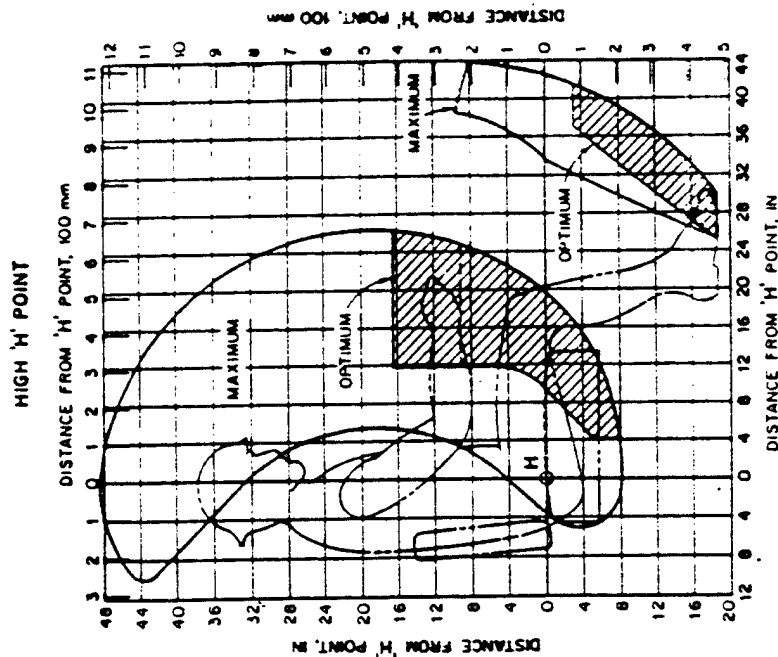
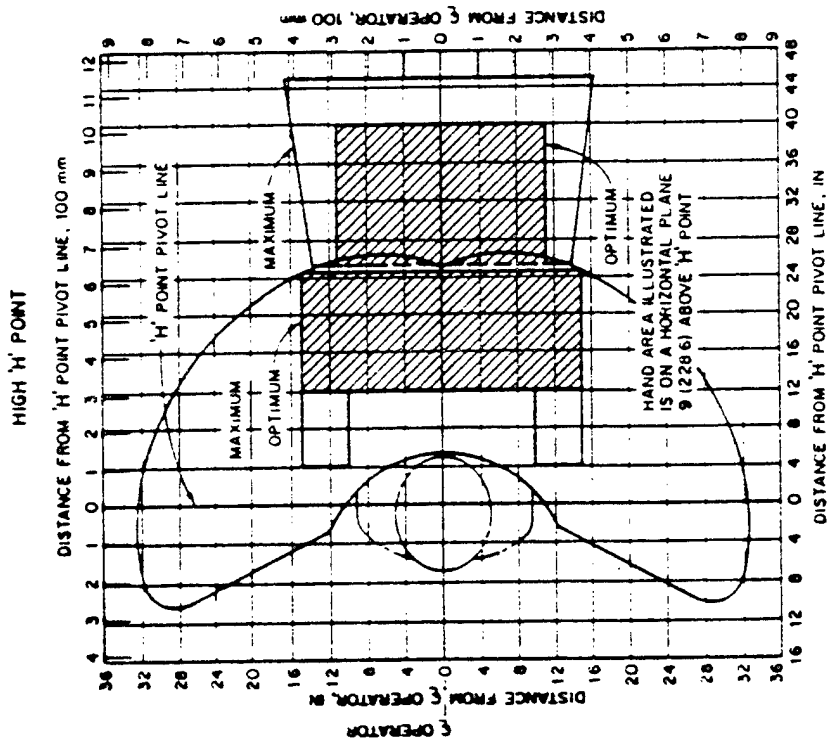

Figure A-2. Optimum and maximum hand and foot control space for high hip-point (H) location. (The figure illustrates a 95th percentile U.S. male construction worker with the seat in the rear position of fore-and-aft adjustment. Provision of 4-inch adjustability accommodates 90% of the operator population. [Source: SAE J898 Recommended Practice, SAE, 1980])

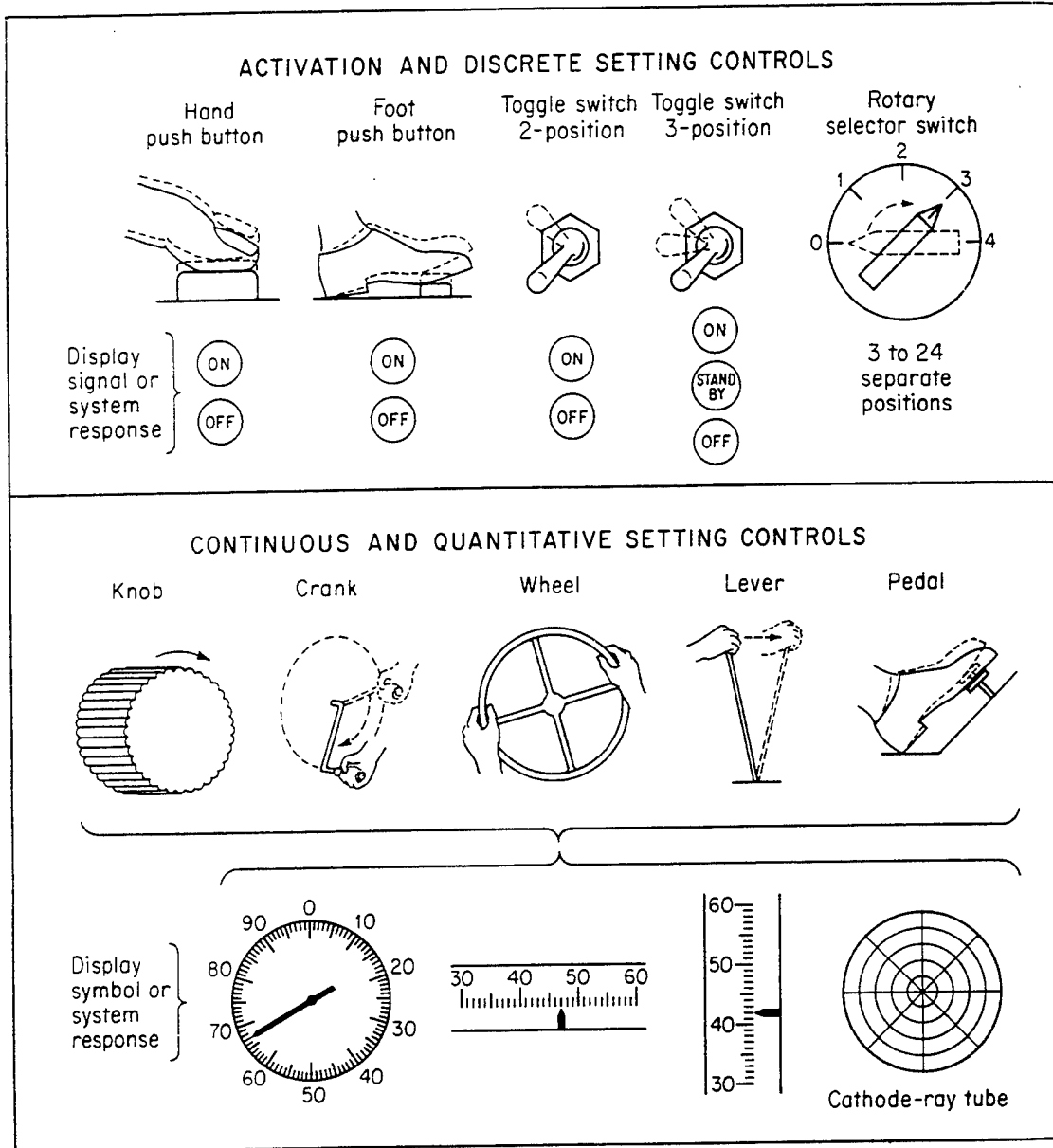

Figure A-3. Examples of some types of control devices and their uses (McCormick, 1970).

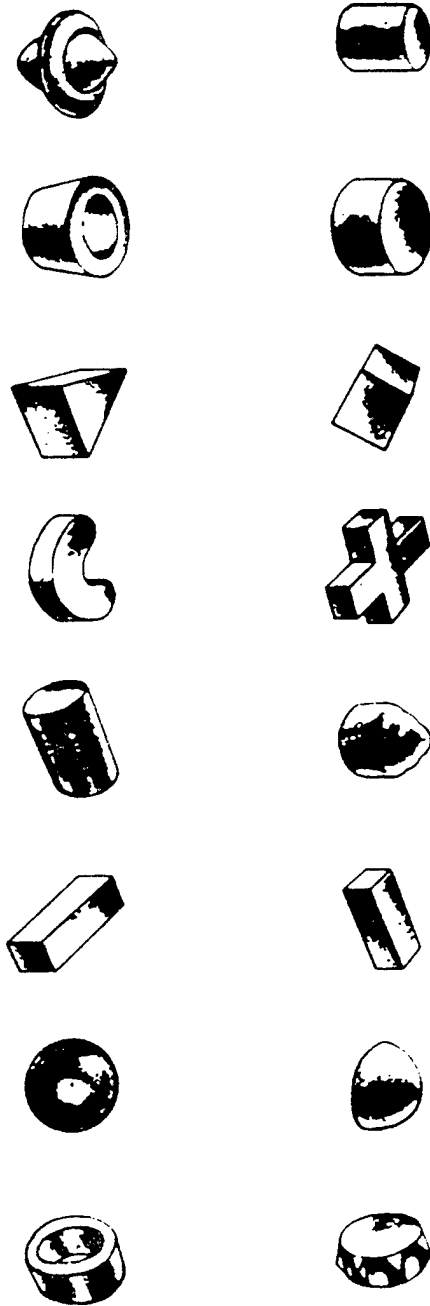

Figure A-4. Two sets of knobs for levers that are distinguishable by touch alone. (The shapes in each set are rarely confused with each other [Jenkins, 1947].)

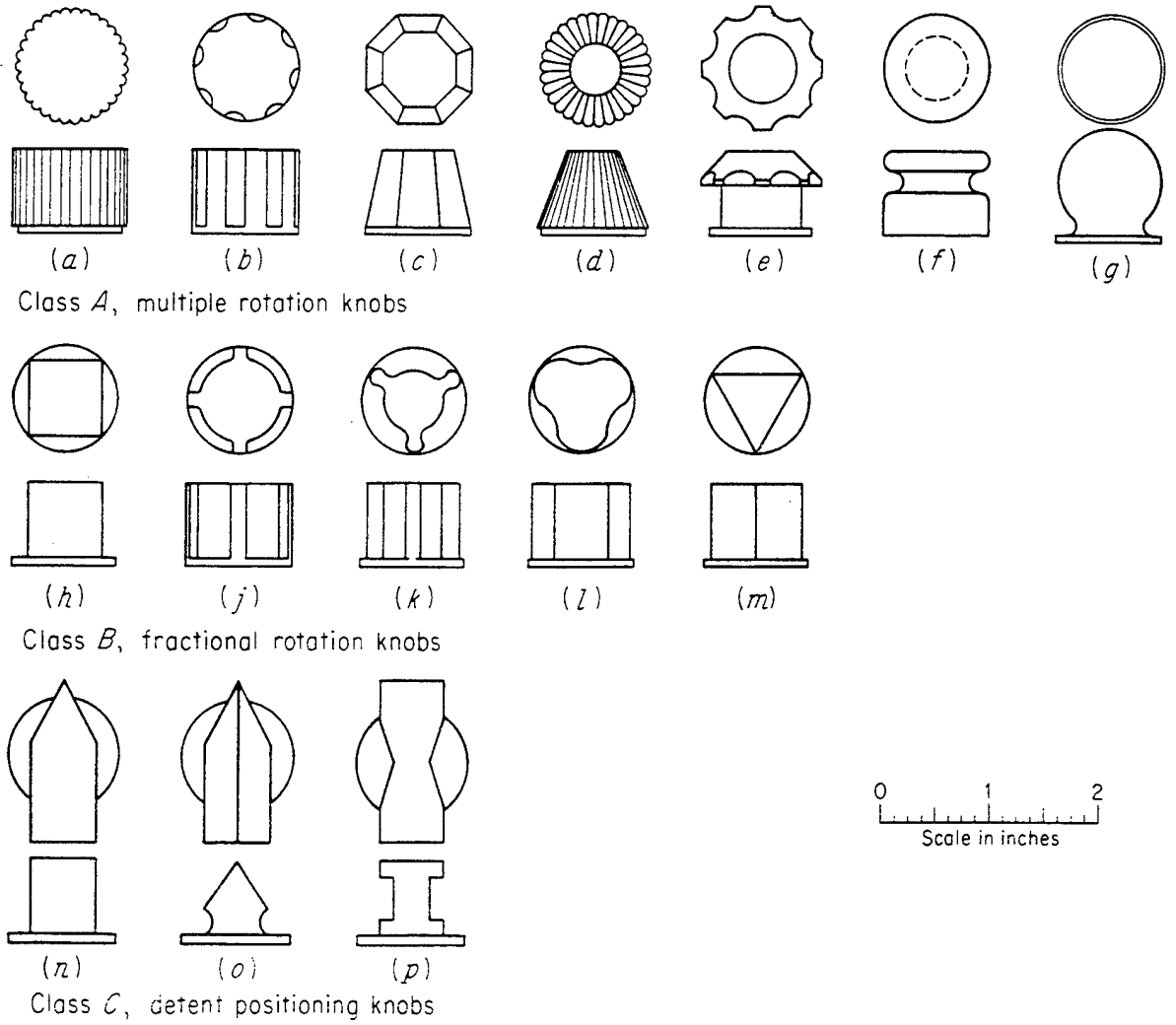

Figure A-5. Knob designs of three classes that are seldom confused by touch (Hunt, 1953).

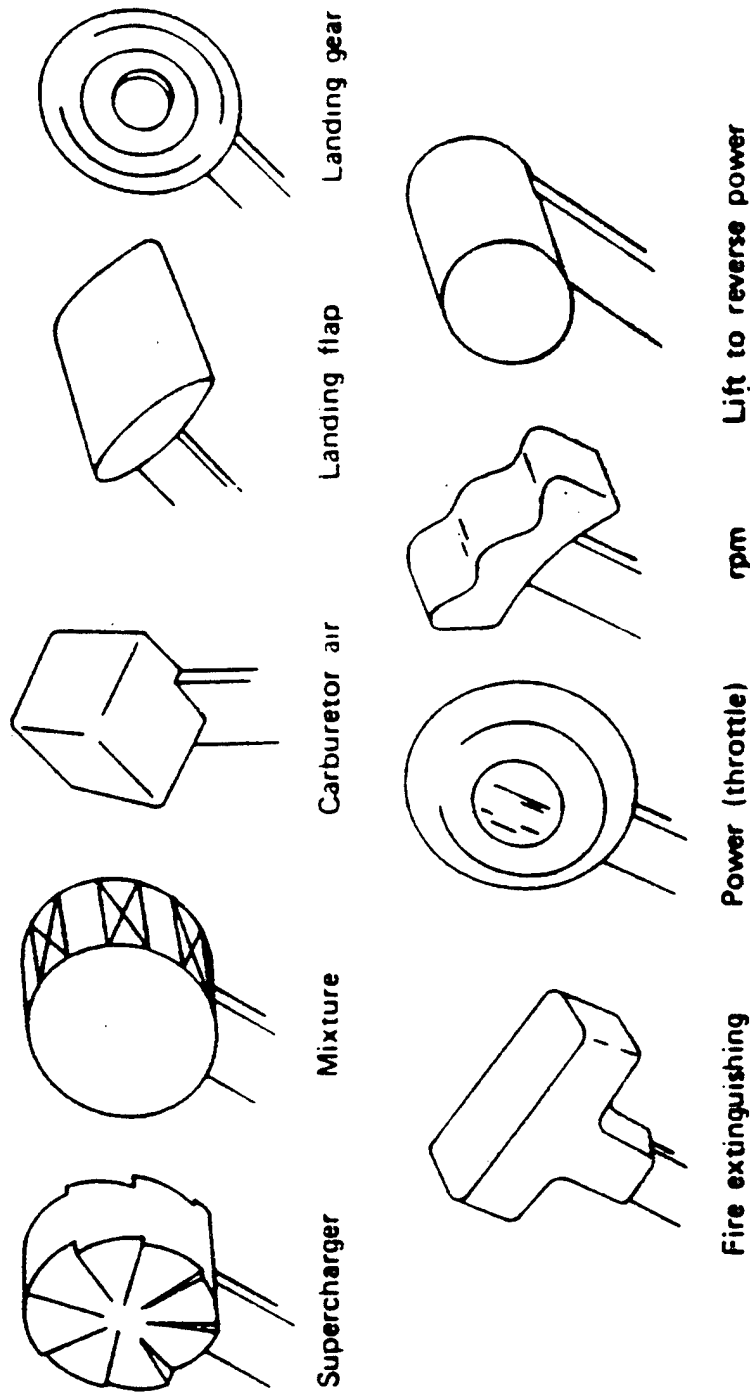

Figure A-6. Standardized shape-coded knobs for U.S. Air Force aircraft. (Some have symbolic association with their functions.)

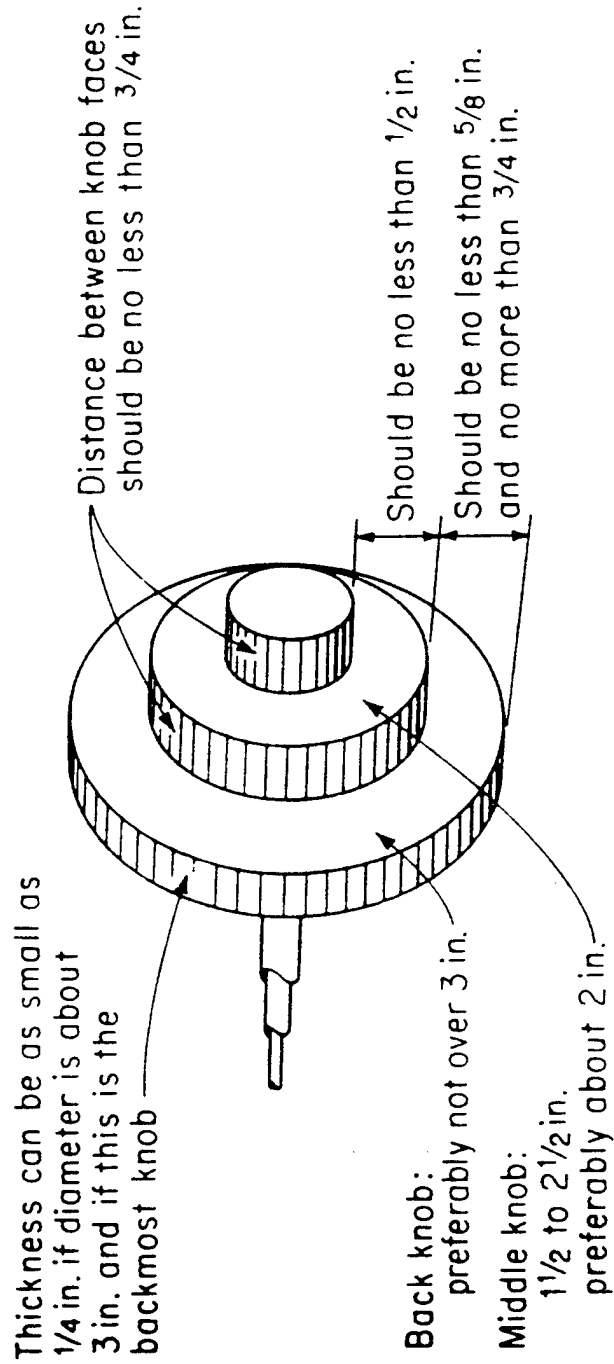

Figure A-7. Dimensions of concentrically mounted knobs that are desirable in order to allow human beings to differentiate knobs by touch (Bradley & Stump, 1955).

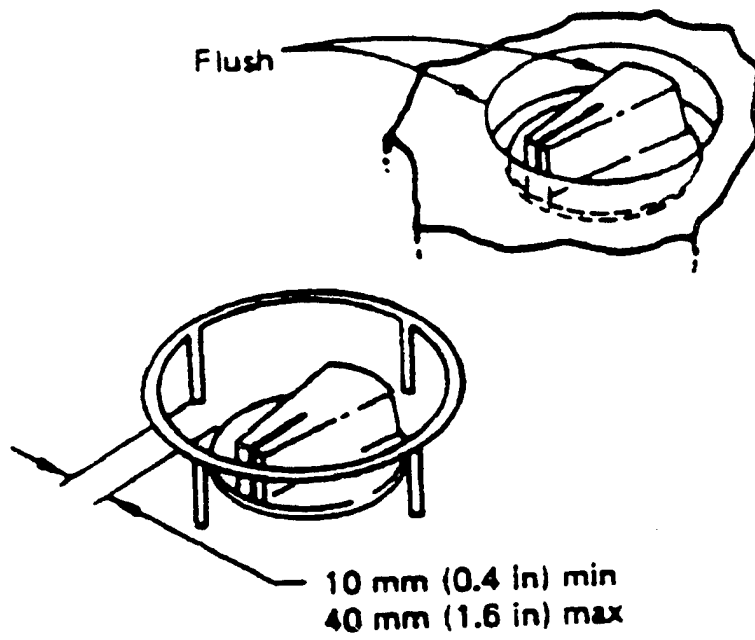

Figure A-8. Rotary switch guard (NASA, 1995).

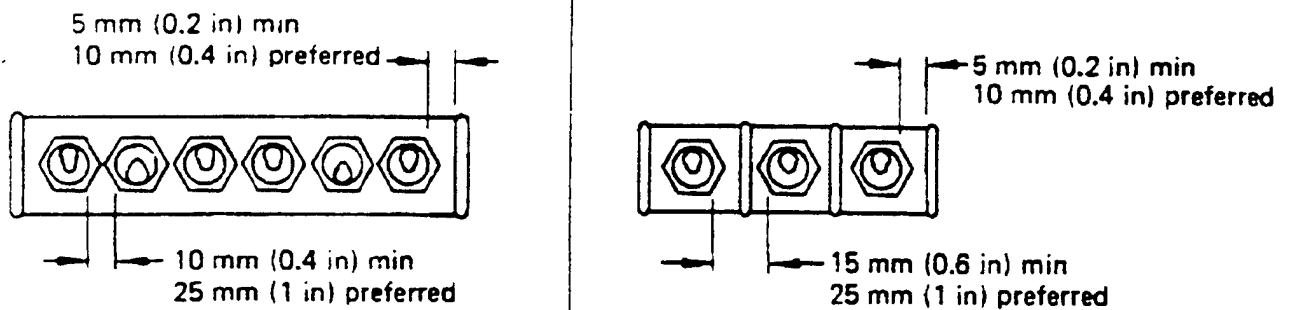
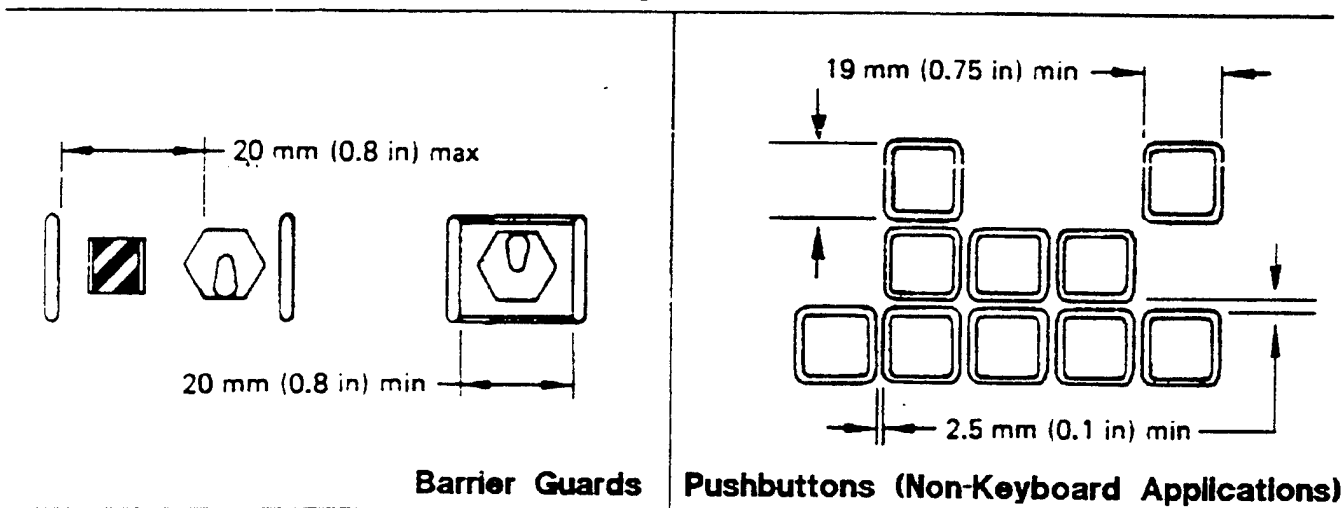
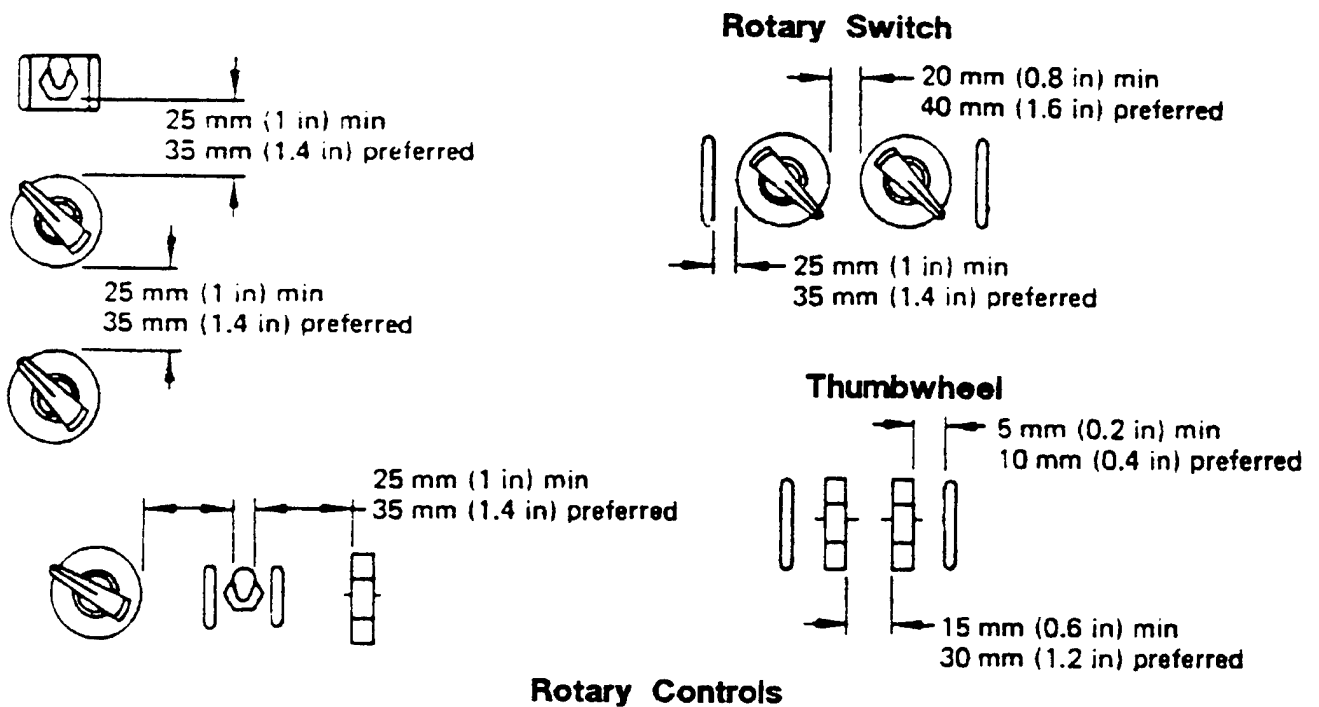

Figure A-9. Control spacing requirements for ungloved operation (NASA, 1995).

<u>NO. OF COPIES</u>	<u>ORGANIZATION</u>
2	ADMINISTRATOR DEFENSE TECHNICAL INFO CENTER ATTN DTIC DDA 8725 JOHN J KINGMAN RD STE 0944 FT BELVOIR VA 22060-6218
1	DIRECTOR US ARMY RESEARCH LABORATORY ATTN AMSRL OP SD TA/ RECORDS MANAGEMENT 2800 POWDER MILL RD ADELPHI MD 20783-1197
1	DIRECTOR US ARMY RESEARCH LABORATORY ATTN AMSRL OP SD TL/ TECHNICAL LIBRARY 2800 POWDER MILL RD ADELPHI MD 207830-1197
1	DIRECTOR US ARMY RESEARCH LABORATORY ATTN AMSRL OP SD TP/ TECH PUBLISHING BRANCH 2800 POWDER MILL RD ADELPHI MD 20783-1197
<u>ABERDEEN PROVING GROUND</u>	
5	DIRECTOR US ARMY RESEARCH LABORATORY ATTN AMSRL OP AP L (TECH LIB) BLDG 305 APG AA
1	LIBRARY ARL BUILDING 459 APG-AA

REPORT DOCUMENTATION PAGE

Form Approved
OMB No. 0704-0188

Public reporting burden for this collection of information is estimated to average 1 hour per response, including the time for reviewing instructions, searching existing data sources, gathering and maintaining the data needed, and completing and reviewing the collection of information. Send comments regarding this burden estimate or any other aspect of this collection of information, including suggestions for reducing this burden, to Washington Headquarters Services, Directorate for Information Operations and Reports, 1215 Jefferson Davis Highway, Suite 1204, Arlington, VA 22202-4302, and to the Office of Management and Budget, Paperwork Reduction Project (0704-0188), Washington, DC 20503.

1. AGENCY USE ONLY (Leave blank)		2. REPORT DATE October 1996	3. REPORT TYPE AND DATES COVERED Final	
4. TITLE AND SUBTITLE Inadvertent Activation of Controls Literature Search			5. FUNDING NUMBERS AMS Code 622716.H700011 PR: 1L162716AH70 PE: 6.27.16	
6. AUTHOR(S) Burcham, P.M.				
7. PERFORMING ORGANIZATION NAME(S) AND ADDRESS(ES) U.S. Army Research Laboratory Human Research & Engineering Directorate Aberdeen Proving Ground, MD 21005-5425			8. PERFORMING ORGANIZATION REPORT NUMBER	
9. SPONSORING/MONITORING AGENCY NAME(S) AND ADDRESS(ES) U.S. Army Research Laboratory Human Research & Engineering Directorate Aberdeen Proving Ground, MD 21005-5425			10. SPONSORING/MONITORING AGENCY REPORT NUMBER ARL-MR-337	
11. SUPPLEMENTARY NOTES				
12a. DISTRIBUTION/AVAILABILITY STATEMENT Approved for public release; distribution is unlimited.			12b. DISTRIBUTION CODE	
13. ABSTRACT (Maximum 200 words) A literature and military documentation search was conducted to identify typical human factors engineering (HFE) design considerations to minimize inadvertent activation of controls. This report discusses findings of the search.				
14. SUBJECT TERMS design human-item interface human factors inadvertent control activation			15. NUMBER OF PAGES 35	
			16. PRICE CODE	
17. SECURITY CLASSIFICATION OF REPORT Unclassified	18. SECURITY CLASSIFICATION OF THIS PAGE Unclassified	19. SECURITY CLASSIFICATION OF ABSTRACT Unclassified	20. LIMITATION OF ABSTRACT	