

Report No. CG-D-01-97

Fire Safety Analysis of the 225' WLB(R) Seagoing Buoy Tender

Chester M. Sprague, P.E.

Center for Firesafety Studies
Worcester Polytechnic Institute
100 Institute Road
Worcester, MA 01609-2280

Derek White, P.E.

Hughes Associates, Inc.
3610 Commerce Drive
Suite 817
Baltimore, MD 21227-1652

Brian Dolph

U.S. Coast Guard
Research and Development Center
1082 Shennecossett Road
Groton, CT 06340-6096



Final Report
December 1996

This document is available to the U.S. public through the
National Technical Information Service, Springfield, Virginia 22161

Prepared for:

U.S. Department of Transportation
United States Coast Guard
Independent Operational Test & Evaluation
1082 Shennecossett Road
Groton, CT 06340-6096

DTIC QUALITY INSPECTED &

19970122 045

NOTICE

This document is disseminated under the sponsorship of the Department of Transportation in the interest of information exchange. The United States Government assumes no liability for its contents or use thereof.

The United States Government does not endorse products or manufacturers. Trade or manufacturers' names appear herein solely because they are considered essential to the object of this report.

The contents of this report reflect the views of the Coast Guard Research & Development Center. This report does not constitute a standard, specification, or regulation.



Anthony L. Rowek
Anthony L. Rowek
Technical Director
United States Coast Guard
Research & Development Center
1082 Shennecossett Road
Groton, CT 06340-6096

1. Report No. CG-D-01-97		2. Government Accession No.		3. Recipient's Catalog No.	
4. Title and Subtitle Fire Safety Analysis of the 225' WLB(R) Seagoing Buoy Tender				5. Report Date December 1996	
				6. Performing Organization Code 181301.9209.1.4.3	
7. Author(s) Chester M. Sprague, P.E., Derek White, P.E., and Brian Dolph				8. Performing Organization Report No. R&DC 23/96	
				9. Performing Organization Name and Address Worcester Polytechnic Institute 100 Institute Road Worcester, MA 01609 Hughes Associates, Inc. 3610 Commerce Drive Suite 817 Baltimore, MD 21227-1652 U.S. Coast Guard R&D Center 1082 Shennecossett Road Groton, CT 06340-6096	
12. Sponsoring Agency Name and Address U.S. Coast Guard Research and Development Center Independent Operational Test & Evaluation 1082 Shennecossett Road Groton, CT 06340-6096				10. Work Unit No. (TRAIS) SHRD Report No. 110	
				11. Contract or Grant No. DTCG39-95-F-E00379	
15. Supplementary Notes The Coast Guard technical point of contact and COTR is Brian Dolph of the U.S. Coast Guard Research and Development Center. The Project Officer is CDR Thacker of the IOT&E Staff.				13. Type of Report and Period Covered Final Report	
				14. Sponsoring Agency Code R&DC IOT&E	
16. Abstract <p>This report documents the results of a comprehensive fire safety analysis of the 225' WLB(R) Seagoing Buoy Tender. The Ship Fire Safety Engineering Methodology (SFSEM) and associated computer program, SAFE version 2.2, were utilized as an analytical tool to perform the analysis. The SFSEM is a probabilistic based fire risk analysis methodology. It is useful to conduct a structured and comprehensive analysis of the performance of all types of surface ships as a fire safety system. The SFSEM provides an integrated framework for analyzing fires on ships in comparison to established fire safety objectives. It accounts for all relevant aspects of fire safety including the growth and spread of fire, the effectiveness of passive design features such as barriers, and active fire protection features such as fixed and portable fire extinguishing systems as well as manual fire suppression.</p> <p>SAFE implements the SFSEM and evaluates the probability of spaces and barriers limiting a fire. The evaluation is conducted on a compartment-by-compartment basis. SAFE calculates the probable paths of fire spread for a user-specified time duration. SFSEM/SAFE has been successfully used to analyze the fire safety design of existing as well as proposed ships.</p> <p>The input data was based on actual data collected during a ship visit on the CGC JUNIPER. Results show that with all passive and active fire protection features in effect the cutter exceeds the established fire safety objectives by a substantial margin. Significant conclusions include that the minimal manning levels proposed for this cutter are feasible due to the well-designed and comprehensive fire and smoke detection system installed in the cutter coupled with the installation of automated fire protection systems in engineering spaces and other compartments with especially hazardous fuel loads. However, the minimal crew size is dependent on shore support to augment their ability to perform the preventive maintenance required to ensure the reliability of the systems they are depending upon. A fire protection doctrine tailored for this class of cutter is included as an appendix.</p>					
17. Key Words Fire Protection, Cutter, Fire Doctrine, Fire Safety, Ship Fire, Engineering Methodology, Coast Guard, Buoy Tender			18. Distribution Statement This document is available to the U.S. public through the National Technical Information Service, Springfield, VA 22161.		
19. Security Classif. (of this report) UNCLASSIFIED		20. SECURITY CLASSIF. (of this page) UNCLASSIFIED		21. No. of Pages	22. Price

METRIC CONVERSION FACTORS

Approximate Conversions to Metric Measures

Symbol	When You Know	Multiply By	To Find	Symbol
LENGTH				
in	inches	* 2.5	centimeters	cm
ft	feet	30	centimeters	cm
yd	yards	0.9	meters	m
mi	miles	1.6	kilometers	km
AREA				
in ²	square inches	6.5	square centimeters	cm ²
ft ²	square feet	0.09	square meters	m ²
yd ²	square yards	0.8	square meters	m ²
mi ²	square miles	2.6	square kilometers	km ²
	acres	0.4	hectares	ha
MASS (WEIGHT)				
oz	ounces	28	grams	g
lb	pounds	0.45	kilograms	kg
	short tons (2000 lb)	0.9	tonnes	t
VOLUME				
tsp	teaspoons	5	milliliters	ml
tbsp	tablespoons	15	milliliters	ml
fl oz	fluid ounces	30	milliliters	ml
c	cups	0.24	liters	l
pt	pints	0.47	liters	l
qt	quarts	0.95	liters	l
gal	gallons	3.8	liters	l
ft ³	cubic feet	0.03	cubic meters	m ³
yd ³	cubic yards	0.76	cubic meters	m ³
TEMPERATURE (EXACT)				
°F	Fahrenheit temperature	5/9 (after subtracting 32)	Celsius temperature	°C

* 1 in = 2.54 (exactly).

Approximate Conversions from Metric Measures

Symbol	When You Know	Multiply By	To Find	Symbol
LENGTH				
mm	millimeters	0.04	inches	in
cm	centimeters	0.4	inches	in
m	meters	3.3	feet	ft
m	meters	1.1	yards	yd
km	kilometers	0.6	miles	mi
AREA				
cm ²	square centimeters	0.16	square inches	in ²
m ²	square meters	1.2	square yards	yd ²
km ²	square kilometers	0.4	square miles	mi ²
ha	hectares (10,000 m ²)	2.5	acres	ac
MASS (WEIGHT)				
g	grams	0.035	ounces	oz
kg	kilograms	2.2	pounds	lb
t	tonnes (1000 kg)	1.1	short tons	st
VOLUME				
ml	milliliters	0.03	fluid ounces	fl oz
l	liters	0.125	cups	c
l	liters	2.1	pints	pt
l	liters	1.06	quarts	qt
l	liters	0.26	gallons	gal
m ³	cubic meters	35	cubic feet	ft ³
m ³	cubic meters	1.3	cubic yards	yd ³
TEMPERATURE (EXACT)				
°C	Celsius temperature	9/5 (then add 32)	Fahrenheit temperature	°F

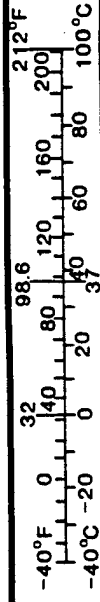

TABLE OF CONTENTS

LIST OF ABBREVIATIONS AND TERMS.....	ix
ACKNOWLEDGEMENTS.....	xx
1. INTRODUCTION	1-1
1.1. BACKGROUND	1-1
1.1.1. WLB (R) SEAGOING BUOY TENDER	1-1
1.1.2. SMALL CUTTER FIRE PROTECTION PROJECT	1-2
1.2. SCOPE	1-2
1.3. OBJECTIVES.....	1-3
1.4. TECHNICAL APPROACH.....	1-3
2. SHIP FIRE SAFETY ENGINEERING METHODOLOGY	2-1
2.1. INTRODUCTION.....	2-1
2.2. SFSEM OVERVIEW.....	2-1
2.2.1. SFSEM FRAMEWORK	2-1
2.2.2. ESTABLISH FIRE SAFETY OBJECTIVES	2-2
2.2.3. ENGINEERING ANALYSES MODULES	2-4
2.2.3.1. Prevent Established Burning Module	2-5
2.2.3.2. Flame Movement Module.....	2-8
2.2.3.3. Smoke Movement Module.....	2-8
2.2.3.4. People Movement Module.....	2-8
2.2.3.5. Structural Frame Module	2-9
2.2.4. SFSEM APPLICATIONS.....	2-9
2.2.4.1. Fire Safety Design Analysis	2-9
2.2.4.2. Fire Investigations.....	2-10
2.2.4.3. Future Applications.....	2-10
2.3. SAFE OVERVIEW	2-11
2.3.1. SAFE FRAMEWORK.....	2-11
2.3.2. AUTOCAD	2-11
2.3.3. DATABASE	2-12
2.3.4. PASCAL PROGRAMS.....	2-12
2.3.5. COMPARISON OF SAFE VERSIONS 2.1A AND 2.2.....	2-12
2.4. FIRE SAFETY ANALYSIS PROCEDURE.....	2-13
2.4.1. PRELIMINARY FIRE SAFETY ANALYSIS.....	2-14
2.4.1.1. Prevention.....	2-14
2.4.1.2. Detection	2-14
2.4.1.3. Containment	2-15
2.4.1.4. Extinguishment.....	2-15
2.4.2. DETAILED FIRE SAFETY ANALYSIS.....	2-15
2.4.2.1. Load Database With Ship's Geometry.....	2-16
2.4.2.2. Conduct Ship Visit.....	2-16
2.4.2.3. Load Safe Input Values.....	2-17

2.4.2.4. Calculate FRI Times And Post-FRI Heat Release Rates.....	2-18
2.4.2.5. Run Probabilistic Model	2-19
2.4.2.6. Analyze Baseline Results	2-20
2.4.2.7. Analyze Fire Protection Alternatives.....	2-21
2.4.2.8. Conduct Cost-Benefit Analysis	2-22
2.4.2.9. Document Results.....	2-22
2.5. PREVIOUS FIRE SAFETY ANALYSES USING SFSEM/SAFE.....	2-22
2.5.1. POLAR ICEBREAKER REPLACEMENT (PIR)	2-22
2.5.2. CGC VIGOROUS (WMEC 627).....	2-23
2.5.3. SMALL CUTTER FIRE PROTECTION PROJECT (SCFP).....	2-23
2.5.4. CGC VINDICATOR.....	2-24
2.5.5. MAIN VERTICAL ZONE LENGTH EVALUATION.....	2-24
3. FIRE SAFETY ANALYSIS OF THE WLB (R)	3-1
3.1. FIRE SAFETY AUDIT.....	3-1
3.1.1. PREVENTION	3-2
3.1.2. DETECTION.....	3-2
3.1.3. CONTAINMENT	3-3
3.1.4. EXTINGUISHMENT.....	3-4
3.2. PRELIMINARY FIRE SAFETY ANALYSIS.....	3-5
3.2.1. FACTUAL INPUT DATA	3-6
3.2.1.1. Ship's Geometry	3-6
3.2.1.2. Automated and Manual Fire Protection Systems	3-6
3.2.1.3. Smoke Detectors.....	3-6
3.2.1.4. Ventilation	3-7
3.2.1.5. Fuel Loads.....	3-7
3.2.2. SUBJECTIVE INPUT DATA	3-7
3.2.2.1. Probabilities of Flame Termination.....	3-7
3.2.2.2. Fire Safety Objectives	3-8
3.2.2.3. Percent Monitored	3-8
3.2.2.4. Fire Growth Models.....	3-8
3.2.3. HISTORICAL RECORDS OF FIRES ON OTHER CUTTERS.....	3-8
3.2.4. PRELIMINARY BASELINE RESULTS (PRE-SHIP VISIT)	3-9
3.3. DETAILED FIRE SAFETY ANALYSIS USING SFSEM/SAFE (POST-SHIP VISIT).....	3-13
3.3.1. LOAD DATABASE WITH SHIP'S GEOMETRY	3-13
3.3.2. CONDUCT SHIP VISIT	3-13
3.3.3. LOAD SAFE INPUT VALUES.....	3-13
3.3.4. CALCULATE FRI TIMES AND POST-FRI HEAT RELEASE RATES	3-14
3.3.5. RUN PROBABILISTIC MODEL	3-14
3.3.6. ANALYZE BASELINE RESULTS	3-15
3.3.6.1. Individual Target Option	3-16
3.3.6.2. Barrier Option	3-20
3.3.6.3. Path Option	3-20
3.3.7. CONDUCT COST-BENEFIT ANALYSIS.....	3-26
3.3.8. DOCUMENT RESULTS.....	3-26
4. FIRE-PROTECTION DOCTRINE	4-1
4.1. BACKGROUND.....	4-1
4.1.1. MAIN SPACE FIREFIGHTING DOCTRINE	4-1

4.1.2. FIRE PROTECTION DOCTRINE	4-1
4.1.2.1. Fire Protection Doctrine Format.....	4-1
4.1.2.2. Scope.....	4-2
4.1.2.3. Future Revisions	4-3
4.2. FIRE PROTECTION DOCTRINE FOR THE WLB (R)	4-3
5. CONCLUSIONS AND RECOMMENDATIONS.....	5-1
5.1. FIRE SAFETY ANALYSIS.....	5-1
5.1.1. PRELIMINARY FIRE SAFETY ANALYSIS	5-1
5.1.2. BASELINE FIRE SAFETY ANALYSIS.....	5-2
5.2. FIRE PROTECTION DOCTRINE.....	5-3

REFERENCES

APPENDICES

- A. COMPARTMENTATION**
- B. BASELINE INPUT DATA**
- C. WLB (R) FIRE SAFETY ANALYSIS RESULTS**
 - Individual Target Output Option
 - Barrier Output Option
 - Path Output Option
- D. PRELIMINARY BASELINE INPUT DATA**
- E. FIRE PROTECTION DOCTRINE**
 - Part A. Principles of Fire Science
 - Part B. Policies for Firefighting on Large Cutters
 - Part C. Procedures for Firefighting on CGC JUNIPER

LIST OF FIGURES

Figure 2.1	Role of the SFSEM in Fire Safety Design Analysis.....	2-10
Figure 3.1	Cumulative L-curve of Fire Path from 1-85-3-L.....	3-21
Figure 3.2	Cumulative L-curve of Fire Path from 4-12-0-E.....	3-22
Figure 3.3	Envelope of Cumulative L-curves of Fire Paths from 4-66-0-E.....	3-23
Figure 3.4	Envelope of Cumulative L-curves of Fire Paths from 4-82-0-E.....	3-24

LIST OF TABLES

Table 2.1	SFSEM Modules.....	2-1
Table 2.2	Fire Frequency Data.....	2-7
Table 2.3	Probabilities of Flame Termination in a Typical Engineerroom.....	2-18
Table 2.4	Standard Scenarios.....	2-19
Table 2.5	Non-Standard Scenarios.....	2-20
Table 3.1	Historical Records of Reported Fires in WMEC's.....	3-9
Table 3.2	WLB (R) Relative Loss Factors, Scenarios 1 & 3, Preliminary Baseline Results.....	3-11
Table 3.3	WLB (R) Relative Loss Factors, Scenarios 1, 4, 7, & 10, Preliminary Baseline Results.....	3-12
Table 3.4	WLB (R) Relative Loss Factors, Scenarios 1, 2, & 3, Baseline Results.....	3-18
Table 3.5	WLB (R) Relative Loss Factors, Scenarios 1, 4, 7, & 10 Baseline Results.....	3-19
Table 4.1	Compartments for Inclusion in Part C of the Fire Protection Doctrine.....	4-5

LIST OF ABBREVIATIONS AND TERMS

- A Curve** - The resulting curve when A values for increasing areas of a compartment are plotted on a graph with probability of flame limitation on the ordinate axis (logarithmic scale) with the origin at the top left and the deck area of the compartment on the abscissa axis (linear scale). See "A Value".
- A Value (%)** - The probability that an automated fixed fire protection system installed in a compartment will successfully extinguish the fire before FRI occurs given that the fire did not self-terminate and was not extinguished by manual firefighting efforts. Each compartment is assigned three A-values: the probability of flame limitation given EB in the room of origin, the probability of flame limitation given EB has occurred in the room as a result of a thermal (Tbar) failure of a barrier, and the probability of flame limitation given EB has occurred in the room as a result of a durability (Dbar) failure of a barrier. In SAFE, these values are abbreviated OA, TA and DA respectively
- Active Fire Protection** - Fire protection features designed to limit flame movement by automatic detection, automatic/automated fire extinguishing systems, and manual suppression systems or equipment. Examples of active fire protection features are: automatic sprinkler systems, fire extinguishers, and trained firefighting teams. See "Passive Fire Protection".
- AFFF** - Aqueous Film Forming Foam. A firefighting agent particularly effective against class B fires.
- Alpha (kilowatts per second squared)** - The fire growth coefficient in the pre-FRI heat release rate algorithm. Generally, alpha is set to .001 for slow growth, .01 for moderate growth, .1 for fast growth and 1.0 for ultra-fast fire growth. Engineering judgment is used to select an appropriate alpha for the combustibles in a compartment and intermediate values are frequently used. See "Pre-FRI Heat Release Rate".
- Alternative Data Set** - Data sets identified as "Alternative" have had the baseline input values to SAFE adjusted as necessary to reflect the impact of the proposed alterations or modifications which affect the ships' firesafety system. See "Baseline Data Set".
- ASTM E119 Test Rating (hours and minutes)** - A rating in hours and minutes specifying time to failure of a material in the standard fire test conducted in accordance with the requirements of ASTM standard test E119.
- AutoCAD** - Commercially available software used to display the plan views of a ship's compartmentation on each deck level.
- Barrier** - Any vertical or horizontal surface which tends to impede, slow, or stop the spread of heat, flames, and combustion products from one space to another. In a ship, barriers may be bulkheads (joiner, watertight, or structural), decks or overheads. See "Zero-Strength Barrier".
- Baseline Data Set** - Data sets identified as "Baseline" utilize input values to the SAFE program based on the physical condition of the ship found during the ship visit and are not influenced by any modifications or alterations which may be proposed as a result of an analysis. See "Alternative Data Set".

Beyler/Peatross Algorithm - The algorithm used in SAFE, version 2.2, to calculate FRI-time for compartment fires. Primary variables include heat release rate, heat loss through the boundaries and the incoming air. See "FRI-Time".

Blackout - The cessation of visible flaming (not to be mistaken for extinguishment which is the cessation of combustion).

Bulkhead - The equivalent in a ship to a wall in a building. Bulkheads can be structural or joiner, insulated or bare. They may be constructed of aluminum, steel, or composite such as marinite or nomex. Together with overheads, they serve to segment the ship into various compartments.

CBO (minutes) - Compartment Burnout - The point in the fire growth curve where exhaustion of all fuel due to pyrolysis occurs.

Ceiling Point - The point in growth of a compartment fire when the flames first touch or involve the ceiling.

Cellulosics - One of two classifications of fuel on board ship. Cellulosics are characterized as ash-producing; examples are wood, paper, and textile products. See "Fuel Load and Petro-Chemicals".

Class A Fire - A fire involving cellulosic type products (wood, cotton, paper, etc.) that produce ash as a combustion product. Water is the primary firefighting agent and extinguishes the fire by cooling the fuel below the ignition point. See "Class B Fire" and "Class C Fire".

Class B Fire - A fire involving flammable liquids (fuel oil, lube oil, gasoline, etc.) that burn vigorously without producing ash. AFFF is the primary firefighting agent and extinguishes the fire by smothering the fire with a thick layer of foam that floats on the surface of the fuel. See "Class A Fire" and "Class C Fire".

Class C Fire - A fire involving energized electrical equipment. Class A fires frequently involve class A or B fires as well. Electrical fires are usually extinguished when the electrical power to the affected equipment is secured, however the associated class A or B fire may continue to burn. CO₂ is the primary firefighting agent and extinguishes the fire by smothering the fire without damaging electrical or electronic components. See "Class A Fire" and "Class B Fire".

CO₂ - Carbon Dioxide. A firefighting agent particularly effective against class C fires.

Combustion - Rapid oxidation in which a fuel pyrolyzes or turns into a vapor and mixes with oxygen at an extremely rapid rate accompanied by the release of intense heat and light visible as flames. See "Fire" and "Pyrolysis".

Compartment - An enclosed space in a ship usually identified with a unique identifying number consisting of deck, forward frame, relation to centerline, and a letter designating the function or type of compartment. See "Plan ID".

Condition of Readiness - One of three material conditions of readiness set by the Commanding Officer of a military ship. All accesses such as doors, hatches and scuttles, and other fittings having damage control value, are labeled X, Y, or Z. In condition Xray all Yoke and Zebra accesses and fittings are open and Xray are closed; in condition Yoke all Zebra

accesses and fittings are open and Xray and Yoke are closed; in condition Zebra, all accesses and fittings are closed.

Configuration - The type of fire protection under consideration in a given fire scenario for a SAFE computer model run. Options include Passive only (I), Passive and Automatic Detection/Fixed Fire extinguishing (I and A), Passive and Manual suppression (I and M), or all three (I, A, and M)

COR - Circular of Requirements. A document that describes the specifications for a proposed ship design.

CSRLI - Cutter Standard Repair Locker Inventory. The allowance for damage control equipment on board a Cutter as specified in a U.S. Coast Guard Commandant Instruction.

CUI - Compartment Use Indicator - An abbreviated designation for a compartment selected from a list provided in SAFE used to define the type or function of the compartment and establish default values for various fire parameters.

Cum L (%) - The accumulated probability that a fire will be limited (thus points on an "L-curve") in this or some previous compartment in a particular fire path. "1 - Cum L", therefore, is the probability that the fire will spread.

D-Adjust (%) - A user-specified parameter that can range from 0 to -99% to modify the Dbar values for a barrier. Usually used to account for deterioration of the barrier. An open door is not considered a derating of the barrier. See "Dbar".

Data Set - A data set describes those characteristics of a ship which affect its performance as a firesafety system. It includes information describing particular aspects of a compartment such as geometry, construction, fuel type and load, automatic detection and monitoring systems, ventilation and fire protection systems. See "Alternative Data Set" and "Baseline Data Set".

Dbar (%) - The probability of a durability failure of a barrier which would permit massive transfer of heat into the adjacent compartment.

DCA - Damage Control Assistant. A designated ship's officer who is responsible for the damage control organization on the ship.

Deck - The equivalent in a ship to a floor in a building. Decks can be continuous or stepped, insulated or bare. They can be constructed of aluminum, steel, or composite such as nomex. They can be covered with tile, carpet, or a poured floor covering such as terrazzo on one side and sheathing, insulation or both on the other. Together with overheads and bulkheads they serve to segment the ship into various compartments.

Destroyed Barrier - When a barrier is "destroyed" in a model run, heat from the burning compartment is transferred to the adjacent compartment if that room is not at full room involvement. The amount of heat transferred is a function of the barrier material and is referred to as residual heat transfer. See "Residual Heat Transfer".

Door - An opening through a bulkhead providing access to a compartment. If a door is open it is equivalent to a durability failure of the associated bulkhead.

- Dur IAM (%)** - The probability of terminating a fire originating in a compartment due to a durability barrier failure. The probability is calculated from a combination of the I, A, and M curves for that room. If the room is a room of origin, Dur IAM is not applicable.
- EB** - Established Burning - The point in the fire growth curve between ignition and FRI when the fire starts to grow exponentially with respect to time. In SAFE, it is assumed that this exponential growth varies with the 2nd power of time. EB is usually considered equivalent to a flame 10" high. EB also signifies the demarcation between fire prevention and the beginning of the ship's response to the fire.
- EEBD** - Emergency Escape Breathing Device. This self contained device provides 15 minutes of oxygen to an individual for the purpose of escaping from a fire.
- Enclosure Point** - The point in the fire growth curve where the fire starts to become influenced by a barrier.
- Engineering Judgment** - The assessment of risk in a probabilistic model utilizing subjective probabilities. In the SFSEM, engineering judgment is synonymous with an analyst's degree of belief. In this context an analyst is a domain knowledgeable individual whose judgment is augmented by all available data including results of deterministic computer models.
- Extinguishment** - The cessation of combustion (not to be confused with blackout which is the cessation of visible flaming.)
- Failed Barrier** - When a barrier has "failed" in a SAFE computer model run, EB is assumed in the adjacent compartment, if that room is not already burning. The failure mode is thermal (T_{bar}) if the barrier's $T_{bar} > D_{bar}$; conversely if $D_{bar} \geq T_{bar}$, the failure mode is D_{bar} .
- FAL** - Frequency of Acceptable Loss. The frequency with which a compartment can sustain a given Magnitude of Acceptable Loss (MAL). The FAL and MAL together establish the firesafety objectives (FSOs) for a given compartment. See "MAL" and "FSO".
- FFS** - Fire Free State. The status of a compartment relative to fire before ignition has occurred.
- Fire** - Combustion. Usually destructive and undesirable in a ship. See "Combustion" and "Pyrolysis".
- Fire Growth Model** - One of 16 models of fire growth defined in SAFE that describe the characteristics of the fuel load in a compartment. The fire growth model determines the fire growth coefficient, alpha, and the maximum heat release rate, Q_{max} . See "Alpha" and "Qmax".
- Fire Path** - The sequential spread of fire from the compartment of origin through a failed barrier into an adjacent compartment, then through another barrier into another space and so on until the fire is limited. Multiple fire paths indicate simultaneous failure of more than one barrier permitting the fire to spread into multiple compartments.
- Firesafety System** - A term used to address the overall performance of a ship as it relates to fire safety. It considers the ship as a whole and accounts for such things as compartment geometry, construction, fuel type and load, automatic detection and monitoring systems, ventilation and fire protection systems.

- Flashover** - A phenomena characteristic of compartment fires denoted by the rapid and sudden propagation of flame through the unburned gases and vapors collected at the top of the enclosure. Flashover is invariably accompanied by full room involvement (FRI). FRI conditions are untenable for humans without self-contained breathing devices.
- FLLR** - Flammable Liquid Line Rupture. A scenario used in SAFE to model a class B spray fire. The key user defined variables include the amount of fuel due to the rupture that is added to the compartment's fuel load, the room of origin and its associated FRI time and I value.
- Frequency of EB (losses per compartment year)** - A frequency based on historic fire casualty data compiled from data provided by the U.S. Naval Safety Center and the Coast Guard's MISREP mishap reporting system.
- FRI** - Full Room Involvement - The point in the fire growth curve when the temperature in a compartment has increased 500C above ambient. FRI conditions include surface burning of all combustibles and survival for unprotected personnel is not possible.
- FRI Time (minutes)** - The elapsed time from EB to FRI calculated in SAFE using the Beyler-Peatross algorithm. See "FRI".
- FSOs** - Fire Safety Objectives - Performance standard, ideally established by cognizant authorities, for a compartment accounting for mission protection, property protection and life safety. The SFSEM is designed to analyze, quantify and compare the ship's performance as a firesafety system to achieve the established FSOs on a compartment basis. The FAL and MAL together establish the FSOs for a given compartment. See "FAL" and "MAL".
- Fuel-Controlled Burning** - When sufficient ventilation is available, fuel controlled burning will occur. The fire is limited by the fuel surface available for combustion. See "Ventilation-Controlled Burning".
- Fuel Load (BTU's/sq ft)** - The total heat energy available for release from combustible materials in a compartment. In SAFE, fuel loads are expressed as fuel load density, where the total fuel load in a compartment is divided by the compartment area. Fuel loads are entered in SAFE for: cellulotics, plastics, and petroleum-based flammable liquids. Cellulotics and plastics are entered in lbs/sq ft while flammable liquids are entered as gallons. The heat energy content of cellulotics is approximately 8000 BTU's/lb; plastics and flammable liquids are approximately 16000 Btu's/lb (flammable liquids are assumed to weigh 8 lbs/gallon).
- FY** - Fiscal Year (For example, FY96 is Oct. 1, 1995 to Sept. 30, 1996).
- Halon** - Halogenated Hydrocarbon. A firefighting agent particularly effective against all classes of fires, but presently banned from further production in accordance with the Montreal Protocol due to its atmospheric ozone-depleting characteristics.
- Hatch** - An opening through a deck providing access to a compartment. If a hatch greater than or equal to 400 square inches is open, it is equivalent to a durability failure of the associated barrier.

Heat Energy Impact (HEI) (kBTU's/sq ft) - The thermal heat flux to which the barrier is subjected during a fire. See "Pre-FRI Heat Release Rate" and "Post-FRI Heat Release Rate".

HVAC - Heating Ventilation and Air Conditioning system. The system on board a ship which supplies and/or exhausts warm and/or cool conditioned air to interior compartments.

I-Curve - The resulting curve when I values for a compartment reaching the enclosure point, the ceiling point, and the room point are plotted on a graph with probability of flame limitation on the ordinate axis (logarithmic scale), with the origin at the top left, and the area of fire involvement on the abscissa axis (linear scale). See "I-Value"

Ignition - Point in the fire growth curve that denotes the beginning of pyrolysis of combustible fuel.

Ign Mode - Ignition Mode. In SAFE one of three ways a compartment can reach EB: orig (as room of origin), therm (due to a thermal (Tbar) failure), or dur (due to a durability (Dbar) failure).

Intermediate Barrier Value (IBV) - The probability that the barrier will be successful in limiting the spread of fire. In SAFE, IBV is calculated as $IBV = P(FPC) * P(BF)$, where P(FPC) is the probability of failure in limiting the fire in the previous compartment (1-Cum L in the previous compartment) and P(BF) is the probability of this barrier failing to limit the fire ($1 - (Tbar + Dbar)$).

I Value (%) - The probability that the fire will self-extinguish at some point between EB and FRI given that the fire was not extinguished by automated systems or by manual firefighting efforts. Each compartment is assigned three I-values: the probability of flame limitation given EB in the room of origin, the probability of flame limitation given EB has occurred in the room as a result of a thermal (Tbar) failure of a barrier, and the probability of flame limitation given EB has occurred in the room as a result of a durability (Dbar) failure of a barrier. In SAFE, these values are abbreviated OI, TI and DI respectively.

L Curve - A graph which plots the cumulative probability of limiting the flame on the Y axis against time or some other suitable parameter on the X axis such as the number of rooms in a fire path or the deck area of a particular compartment. Convention calls for plotting 0 as the probability of limiting the flame at the top of the Y axis and 100% as the probability of limiting the flame on the X axis. See "cum-L"

L-Value (%) - The probability that a fire will be limited in a given compartment calculated from the I, A, and M values for that compartment. See Figure 6-9 for a graphic representation of the L-curve for a compartment.

MAL - Magnitude of Acceptable Loss - The severity of damage that can be tolerated in a compartment. FAL and MAL together establish the FSOs for a given compartment. See "FAL" and "FSOs".

Material ID - A three-character identifier to describe one of a compartment's barriers selected from the catalog of available barrier materials.

M-Curve - The resulting curve when M-values for increasing areas of a compartment are plotted on a graph with probability of flame limitation on the ordinate axis (logarithmic scale) with

the origin at the top left and the deck area of the compartment on the abscissa axis (linear scale). See "M-Value".

M Value (%) - The probability that manual firefighting efforts will successfully extinguish the fire before FRI occurs given that the fire did not self-terminate and was not extinguished by automated fire protection systems. Each compartment is assigned three M-values: the probability of flame limitation given EB in the room of origin, the probability of flame limitation given EB has occurred in the room as a result of a thermal (Tbar) failure of a barrier, and the probability of flame limitation given EB has occurred in the room as a result of a durability (Dbar) failure of a barrier. In SAFE, these values are abbreviated OM, TM and DM respectively

NFTI - Naval Firefighting Thermal Imager. A hand held device used to locate the source of flames in a compartment by sensing the temperature of the fire.

Non-Standard Scenario - Similar in all respects to a Standard Scenario except that it considers reduced levels of available fire protection systems.

NSTM - Naval Ship's Technical Manual. A set of regulations and guidelines issued by the U.S. Navy and frequently cited in U.S. Coast Guard regulations.

NWP - Naval Warfare Publication. A U.S. Navy publication.

OBA - Oxygen Breathing Apparatus. A self contained device that supplies oxygen to facilitate firefighting in untenable atmospheres.

One-Shot Halon System - A total flooding system with the capability to completely flood the protected space one time with the required concentration level of Halon 1301.

Overhead - The equivalent in a ship to a ceiling in a building. Overheads can be continuous or stepped, insulated or bare. They can be constructed from steel, aluminum, or a composite material such as nomex or celotex. They can be covered with sheathing, insulation, or both on one side and covered with carpet, tile or a poured floor such as terrazzo on the other. Together with bulkheads, they serve to segment the ship into various compartments.

P-250 - A portable gasoline-powered pump used for firefighting and dewatering.

Passive Fire Protection - Fire protection features designed to limit flame movement by their presence alone. Barriers are the best example of passive fire protection, intumescent coatings, fire doors, fuel load distribution, and insulation of hot surfaces are other examples. See "Active Fire Protection".

Percent Heat Release (%) - A percentage of the remaining heat in a burning compartment that is transferred to an adjacent compartment as a result of a durability (Dbar) failure of the barrier. The percent heat release is a function of the barrier material and can be found in the catalog of barrier materials. See "Residual Heat Transfer".

Percent Monitored At Sea (%) - An estimate of the percentage of time around the clock while a ship is underway that a compartment is monitored to detect the presence of smoke and flames. Both personnel and fire/smoke/heat detectors can monitor a compartment.

Percent Monitored In Port (%) - An estimate of the percentage of time around the clock while a ship is in port that a compartment is monitored to detect the presence of smoke and flames. Both personnel and fire/smoke/heat detectors can monitor a compartment.

Petro-Chemicals - One of two classifications of fuel on ships. Petroleum-based chemical products are characterized by having twice the heat energy per pound than cellulose type of fuel. Examples of petro-chemicals include: flammable liquids and synthetic polymers such as plastics and polyester. See "Fuel Load and Cellulosics".

PIR - Polar Icebreaker Replacement - Design for the replacement of the Coast Guard's Polar Icebreaker class. The PIR project in 1987 was the first time the SFSEM was utilized to analyze the firesafety performance of a Coast Guard Cutter.

PKP - Potassium Bicarbonate. A dry chemical firefighting agent frequently used in portable fire extinguishers. The only authorized dry chemical portable fire extinguisher permitted on board Coast Guard Cutters.

Plan ID - A unique identifier for compartments as used in the Booklet of General Plans and other ship's drawings. The four fields that make up the identifier are: deck number, forward frame number, relationship to the centerline (1 for starboard, 2 for port, 0 for centerline), and compartment use indicator. Examples are 3-66-0-E, and 01-40-2-L.

Post-FRI Heat Release Rate (kW) - The rate that heat is released from the burning fuel in a compartment during the fully developed fire realm and calculated in accordance with the following expression: $Q = 1500 * A * H^{.5}$. In SAFE, the ventilation factor, $A * H^{.5}$, takes into account the height and area of all ventilation openings. Open doors, hatches, windows, etc. are assumed to be ventilation openings. The numerical coefficient, 1500, assumes stoichiometric burning conditions.

Pre-FRI Heat Release Rate (kW) - The rate that heat is released from the burning fuel in a compartment during the fire growth realm and calculated according to: $Q = \text{Alpha} * t^2$. The heat energy produced is used as a key variable in the Beyler-Peatross algorithm for calculating compartment fire temperatures; when the temperature exceeds ambient by 500 degrees celsius, full room involvement (FRI) is assumed to exist in the compartment. See Appendix B.

Pyrolysis - The conversion of solid fuel into flammable vapor by the application of heat.

Qmax - The maximum permissible value of the heat release rate. Qmax is the upper limit for Q in the Beyler-Peatross algorithm and is a function of the fire growth model. See "Fire Growth Model".

Radiation Point - The transition point between smoldering combustion and the point where a fire grows proportionally to time squared. This point (beginning of exponential fire growth) is also referred to as Established Burning (EB) since this is the point where radiational feedback to the fuel bed becomes the predominant mode of heat transfer.

Relative Frequency of Acceptable Loss|Fire Free State - Relative Frequency of Acceptable Loss of a compartment given Fire Free State, calculated in SAFE by summing the probabilities of a target compartment or set failing to meet its FSOs over all fire paths, from all possible rooms of origin, multiplied by the frequency of EB in each room of origin.

Residual Heat Transfer (%) - The amount of unburned fuel that is transferred from a burning compartment to an adjacent room upon barrier failure if the adjacent compartment is not at full room involvement. This parameter is a function of the barrier material and can be found in the catalog of available barrier materials. See "Percent Heat Release".

RLF - Relative Loss Factor - RLFs are calculated in SAFE as a means of assessing whether a target compartment or set meets FSOs. A Relative Loss Factor > 1 indicates that a target compartment has failed to meet its FSOs. This factor is determined by multiplying the target's Relative Frequency of Acceptable Loss given Fire Free State of the target in failures/year (calculated during a given run of SAFE) by the assigned frequency of acceptable loss in years. A target is considered lost if its level of fire involvement in a given path exceeds the level specified by its MAL rating.

Room of Origin - The compartment in a fire path where EB first occurs.

Room Point - The point in the growth of a compartment fire where flames fully involve the compartment. See "Full Room Involvement".

SAFE - Ship Applied Fire Engineering - The computerized implementation of the SFSEM. SAFE is actually an integrated series of computer programs utilizing AutoCAD and the INFORMIX relational database management system

Scenario - A situation defined by the user before executing a SAFE probabilistic model run. Such parameters as run time, ship location, material condition of readiness and firefighting configuration are specified.

SCFP - Small Cutter Fire Protection. Project sponsored by Commandant (G-ENE) to analyze firesafety on cutters less than 180' in length.

SFSEM - The Ship Fire Safety Engineering Methodology. A probabilistic-based risk analysis methodology used to analyze all aspects of the ship's performance in response to a fire compared to pre-established FSOs.

Shell Plating - The ship's hull consisting of the underwater body and the freeboard Main Deck and below. The ship's superstructure is above the Main Deck. Shell plating can be steel or aluminum.

SHIPALT - Ship Alteration. A document that describes an authorized change to the configuration, compartmentation, or other major alteration to a ship. The purpose of SHIPALTS is to standardize the configuration of all ships in a class.

Ship Location - A ship is either "at sea" or "in port" for the purpose of setting up a model run in SAFE.

SOLAS - Safety of Life at Sea. An international convention prompted by the Titanic disaster and amended several times since that time that establishes international regulations for building ships to ensure the safety of passengers.

Standard Scenario - Scenarios that describe a ship's location and material condition of readiness with passive automated and manual fire protection capabilities in effect. Since this describes a ship under normal operating conditions, these scenarios are referred to as standard scenarios. See "Non-Standard Scenario"

Stepped Deck - That portion of a deck which is not in the same horizontal plane as the majority of the deck.

Stoichiometric - A term that describes ideal burning which assumes there is sufficient oxygen to ensure 100% combustion of available fuel. Stoichiometric burning produces the hottest fire temperatures, therefore sufficient ventilation to produce stoichiometric conditions is assumed in the SFSEM where fire protection systems should be designed for worst case conditions.

Superstructure - The ship's structure above the Main Deck. The superstructure can be steel or aluminum.

T-Adjust (%) - A value that can range from 0 to -99% that is applied to the Tbar value of a specified barrier to account for cracks or other flaws that would reduce its ability to resist a thermal or hot spot failure. An open door or window is not considered a derating of the barrier.

Target - A compartment or set of compartments which are analyzed in a probabilistic model run for the frequency and magnitude of fire loss due to fires started in every possible room of origin. A target set of compartments may be selected because they contain components necessary to perform a ship's mission. In this manner the likelihood of mission failure can be ascertained.

Tbar (%) - The probability of a thermal failure of a barrier which would permit a small, hot spot ignition in the adjacent compartment.

Therm IAM (%) - The probability of terminating a fire originating in a compartment due to a thermal barrier failure. The probability is calculated from a combination of the I, A, and M curves for that room. If the room is a room of origin, Therm IAM is not applicable.

Two-Shot Halon System - A total flooding system with the capability to completely flood the protected space two times with the required concentration level of Halon 1301. This system is designed such that each shot of Halon is released from a different location in the vessel.

USCGC - United States Coast Guard Cutter

Vent Area (sq in) - The sum of all the ventilation openings in a compartment, excluding doors and hatches but including ventilation grates in a door. Used to calculate the post-FRI heat release rate. See "Post-FRI Heat Release Rate".

Vent Height (in) - The average of the vertical height of all vent openings in a compartment. The height of the compartment itself is used for horizontal vents.

Ventilation Controlled Burning - When insufficient ventilation is available, ventilation controlled burning occurs. The fire is limited by the air supply available for combustion. See "Fuel Controlled Burning".

Ventilation Factor - A factor, $A \cdot H^5$, that describes the primary variables in the post-FRI heat release rate calculation in SAFE. These variables are the area and height of the ventilation opening(s) in a compartment. In compartments with multiple vents, areas are summed and heights are averaged.

WLB (R) - Seagoing Buoy Tender. The "R" indicates that this is a replacement for an existing class of buoy tender.

WLM (R) - River Buoy Tender. The "R" indicates that this is a replacement for an existing class of buoy tender.

XRAY, YOKE and ZEBRA - Material Conditions of Readiness. Successively increasing levels of watertight integrity for controlling damage. At each level, additional access closures, valves and fittings are required to be closed to limit fire and flooding.

Zero-Strength Barrier - An imaginary boundary used to model extremely long passageways and multiple deck compartments. The barrier is presumed to have no thermal resistance.

ACKNOWLEDGMENTS

The authors are indebted to the numerous people who generously contributed their time and expertise in conducting the fire safety analysis of the USCGC JUNIPER. Mr. Ajay Prasad worked diligently with AutoCAD to produce the ship's drawings and SAFE to produce numerous runs of the probabilistic model during the fire safety analysis phase of the project. In addition he supported the preparation of the final report by creating many of the appendices. Mr. Paul Sincaglia provided excellent support during the project. Dr. Craig Beyler and Mr. Joseph Scheffey also provided invaluable comments based on their review of the text and fire protection doctrine respectively. Ms. Betty Romberg and Ms. Doris Rich cheerfully provided essential assistance to Mr. Ajay Prasad with AUTOCAD and SAFE. The professional and dedicated contributions provided by these individuals and the entire project team is gratefully acknowledged and truly appreciated.

1. INTRODUCTION

1.1. BACKGROUND

The U.S. Coast Guard operates a large fleet of buoy tenders to maintain an extensive system of floating and fixed aids to navigation in the navigable waters of the United States including harbors, rivers, and coastal regions. The fleet includes 180' seagoing buoy tenders, 157' and 133' coastal buoy tenders, and a variety of construction and river tenders that operate on the "western" rivers such as the Mississippi, Missouri, and Ohio Rivers as well as selected bays and harbors such as the Chesapeake Bay. The fleet is geographically dispersed over the Atlantic and Pacific seaboards, Alaska, Hawaii, the Gulf of Mexico and all five Great Lakes. Due to the age of the existing cutters in the buoy tender fleet, the Coast Guard is in the process of replacing two classes of buoy tenders.

The Coast Guard has awarded two contracts to Marinette Marine Shipyard, Marinette, WI, to design and build a replacement class of buoy tenders for the aging 180' seagoing buoy tender and 157' coastal buoy tender. "WLB (R)" is the designation for the replacement seagoing buoy tender. "WLM (R)" is the designation for the replacement coastal buoy tender. Marinette Marine is responsible for designing and building these ships in accordance with the guidance provided in the Circular of Requirements (COR) and other applicable regulatory authorities. The COR requires installation of certain firefighting equipment and ensures that fire safety is considered in the design. However, a formal fire safety analysis is not required by the COR. [1]

A fire safety analysis of the WLM (R) was conducted as part of the Small Cutter Fire Protection (SCFP) project. The results of this project clearly demonstrated the utility of analyzing the fire safety design early in the construction of the lead cutter in a new class of ships. The WLM (R) was studied in the conceptual design phase before construction of the vessel had begun. The lead cutter, CGC JUNIPER, in the WLB (R) class had been completed when this project was begun, however the ship had not yet been delivered to the Coast Guard. The following sections provide additional background information on the WLB (R) Seagoing Buoy Tender and the SCFP project.

1.1.1. WLB (R) SEAGOING BUOY TENDER

A fire safety analysis of the lead ship in the WLB (R) class was desired by the Coast Guard for two primary reasons:

- Possible deficiencies in the fire safety design identified early in the construction of the class would permit cost-effective corrections for remaining cutters in the class.
- The planned crew size for this class of cutter is much smaller than other cutters of comparable length and complexity, consequently there is a concern that adequate firefighting equipment and fire protection systems are installed to supplant the protection offered by larger crews on other ships.

A fire safety analysis is enhanced if the ship is available to collect actual data concerning fuel loads and other details pertinent to the fire safety design of the ship. Since the JUNIPER had not been delivered to the Coast Guard when the project started, it was not possible to visit the ship until late in the project. Therefore the preliminary results of the fire safety analysis of the ship

were based on information available from the COR and ship's drawings. After the ship was delivered to the Coast Guard a ship visit on JUNIPER was accomplished so that actual data could be collected and subsequently utilized in the analysis.

1.1.2. SMALL CUTTER FIRE PROTECTION PROJECT

The Small Cutter Fire Protection Project (SCFP) was initiated to examine all aspects of fire protection in small cutters (less than 180' in length). The original scope of the SCFP spanned nine classes of small Coast Guard Cutters including most of the patrol boats, tugboats and construction/river tenders in the Coast Guard fleet. The primary objectives included analyzing the fire safety of the nine cutter classes and recommending improvements where needed. The deliverables in the project included interim and final technical reports which incorporated a fire protection doctrine tailored to suit each class of cutter studied. The technical approach for studying the cutters specified the use of the Ship Fire Safety Engineering Method (SFSEM) as the analytical tool to evaluate shipboard fire safety.

The SFSEM is a probabilistic-based risk analysis methodology which provides an integrated framework to account for all relevant aspects of shipboard fire protection. The Theoretical Basis of the SFSEM is documented and available in the Safety and Human Resources Division Library at the U.S. Coast Guard Research and Development Center. [2] The SFSEM is designed to evaluate the ship's performance compared to pre-established fire safety objectives (FSO). The methodology quantifies the contribution of passive and active fire protection systems, thus it provides a means for analyzing and comparing design alternatives to improve the overall fire protection on the cutter. Since the SFSEM had only been used once before in the Polar Icebreaker Replacement Project, a secondary objective was established in the SCFP to analyze the utility of this methodology and identify areas of improvement.

As documented in the final technical report for the SCFP project, the utility of the SFSEM to analyze existing ships, the ability to identify problem compartments which fail to meet fire safety objectives, and the ability to analyze the effectiveness of hypothetical design alternatives to correct the problems was clearly demonstrated. [3] The limitations of SAFE are also documented in the Theoretical Basis of the SFSEM.[2] The SFSEM was successfully used in a similar manner to analyze the fire safety design of the WLM (R) in the conceptual design phase. The SFSEM was again specified as the analytical tool to evaluate the fire safety of the WLB (R).

1.2. SCOPE

The scope of this project is limited to analyzing the fire safety of the CGC JUNIPER, the lead ship in the 225' WLB (R) Seagoing Buoy Tender class. A ship visit was conducted on the CGC HORNBEAM early in the project to gain insight into typical fuel loads and standard operating procedures for an existing 180' seagoing buoy tender. A ship visit was conducted on the CGC JUNIPER late in the project after the ship was delivered to the Coast Guard. Thus preliminary results of the fire safety analysis of the WLB (R) were based on the COR, the ship's drawings and the HORNBEAM ship visit however the latter detailed fire safety analysis of the WLB (R) was based on data collected during the JUNIPER ship visit.

The format for a new and expanded fire protection doctrine was developed during the SCFP project. The doctrine provides recommended procedures for fighting all classes of fires in

all types of compartments whereas the existing main space fire doctrine only deals with class B fires in the main machinery spaces. Due to the planned minimal crew size and the existence of numerous automated fire protection systems on the WLB (R), the scope of this project was expanded to include development of a fire protection doctrine for the WLB (R) similar to those developed in the SCFP project.

1.3. OBJECTIVES

Two primary objectives were established for this project. The first and most important primary objective was to thoroughly evaluate the fire safety design of the WLB (R) class. In this context, "fire safety design" includes the compartmentation, outfitting and construction materials, fire protection systems, firefighting equipment, firefighting procedures and tactics and any other aspect of the proposed design that pertains to fire safety. Since the design of the ship is subject to constant improvement, this analysis was based on information concerning the design available to the USCG Research and Development Center in September 1995. Initially this information consisted of the COR and the Booklet of General Plans supplemented by a visit to the CGC HORNBEAM in October 1995. The accuracy of the information was greatly improved as a result of the ship visit to the CGC JUNIPER in March 1996.

The WLB (R) was to be studied in its normal operating configuration, in port and at sea, with a full complement of outfit and crew; it was assumed that the ship would be intact, and not subject to fires resulting from enemy action or arson. Compartments which fail to meet pre-established fire safety objectives were to be thoroughly studied to determine reasons for the problem. This includes an analysis of all the fire paths which contributed to the failure of the compartment to meet the FSOs. Hypothetical alternatives to improve the fire safety of any problem compartments were to be identified and a cost benefit analysis conducted to form the basis for recommendations to Coast Guard Headquarters. The Coast Guard, could then consider the costs that would be incurred in issuing an engineering change proposal as opposed to retrofitting the delivered ships using the SHIPALT process.

The other primary objective was to develop a tailored fire protection doctrine for the WLB (R). As a result of the work done in the SCFP, the fire protection doctrine for Coast Guard Cutters has been significantly expanded in scope and reformatted into three parts. Since Parts A and B of the fire protection doctrine in the new format were developed previously and apply to this cutter, only Part C requires development as part of this project. The entire fire protection doctrine is included in Appendix E of this report for the sake of completeness. The doctrine specifies procedures for combating class A, B, and C fires in port and at sea in all types of compartments in the cutter. The scenarios are limited to those that are reasonable to expect, for example a class A fire in the Berthing Area, a class B fire in the Engine Room, and a class C fire in the Pilot House. Only procedures, tactics, and equipment currently authorized by SHIPALT and in consonance with published Commandant policy in the Naval Engineers Manual (Commandant Instruction M9000.6B) and other official documents such as NSTM, Chapters 555 and 079 are incorporated in the new doctrine. [4, 5, 6]

1.4. TECHNICAL APPROACH

This project is organized into four phases:

- Conduct background research
- Perform fire safety analysis
- Develop fire protection doctrine
- Prepare final report

The background research phase includes a review of the drawings and specifications in the COR that describe the details of the fire protection equipment and systems planned for installation in the vessel. This phase also includes modeling the compartmentation in AutoCAD as a necessary prerequisite for using the SFSEM and its related computer programs, SAFE, which implements the Method. The fire safety analysis phase includes a thorough review of the baseline fire safety levels of the ship on a compartment basis. This phase also includes a study of alternative enhancements to improve the fire safety of any compartments which fail to meet their FSOs or to study particular ship design features that pertain to fire safety. Finally, the fire safety analysis phase includes the identification of probable fire paths from selected rooms of origin to enhance the crew's firefighting training. The fire protection doctrine phase involves the development of Part C which describes the procedures and tactics for combating all classes of fires in all types of compartments. Finally, the results of the study are documented in this final report and the new doctrine is included as Appendix E.

The technical approach used to perform the fire safety analysis is similar to that used in the SCFP and documented in the Theoretical Basis of the SFSEM and the SAFE User Manual. [2, 7] These documents describe a nine step procedure for conducting the analysis. This procedure has been established and refined over the past nine years during which thirteen classes of Coast Guard cutters have been analyzed. The final reports for these studies are available at the USCG Research and Development Center. [3, 8, 9, 10, 11, 12]

The approach for performing a fire safety analysis on the baseline data set uses the individual target output option in SAFE to determine and rank-order baseline fire safety levels of every compartment compared to pre-established fire safety objectives. In this context, "baseline" refers to the ship "as is" without any hypothetical improvements in the fire safety design. The technical approach used in the SCFP was altered for the WLB (R) due to its much larger size and many more compartments compared to small cutters. The changes included using default values as starting points for fuel loads, FSOs and probabilities of flame limitation and then tailoring these values for observed conditions instead of individual calculations for each compartment. It was discovered recently that the target output options in SAFE provide imprecise but conservative results. Therefore the target option results were augmented by the barrier and path options. These results also permit the determination of probable fire paths from compartments determined to be likely rooms of origin.

The technical approach used to develop the fire protection doctrine for the WLB (R) included analyzing the existing main space fire protection doctrine. This provided a good starting point for developing procedures to combat class B fires in the machinery spaces. The new doctrine was developed taking into account the feedback from various reviews of the final reports submitted in the SCFP. The new doctrine also incorporates procedures for class A and class C fires as well. Information from a variety of sources was utilized to develop these procedures and tactics including:

- Naval Ships Technical Manual, chapters 555 and 079, vols. 1-4 [5, 6]
- Surface Ship Survivability Manual, NWP 62-1 (Rev C) [13]
- Cutter Casualty Control Manuals [14]
- Vessel Safety Manual [15]
- Marine Fire Prevention, Firefighting, and Fire Safety [16]

Each cutter in the WLB (R) class will have to tailor part C of the new doctrine to account for any differences between themselves and the CGC JUNIPER. Differences may exist due to uncompleted (or unauthorized) SHIPALTS and other changes pertaining to the fire safety design of other ships in the class. In addition, differences may exist due to compartmentation and other changes that are peculiar to a sub-class. Crew members, who have been transferred to JUNIPER from other small cutters, will have to study both Parts B and Part C of the doctrine for their new ship. In addition, damage control personnel or others generally familiar with fire science will not have to study Part A. Maintenance of the new fire protection doctrine should be simplified. The Commandant would be the appropriate authority responsible for updating and maintaining Parts A and B of the doctrine. The individual cutter would tailor and maintain Part C in accordance with the guidance provided in Parts A and B.

Section 2 of this report provides an explanation of the SFSEM and its implementing computer programs, SAFE. An understanding of the SFSEM/SAFE is essential to comprehending the results of the fire safety analysis discussed in section 3. These results identified certain compartments which are more likely to be rooms of origin than other compartments in the ship. Consequently a discussion is included in section 3 concerning probable fire paths from these rooms of origin. Section 4 provides an explanation and background information concerning the fire protection doctrine developed for the WLB (R). Section 5 provides the conclusions and recommendations that were developed as a result of the preliminary and detailed fire safety analyses accomplished in this project. Appendix A includes a tabulation of all compartments in the WLB (R) as well as profile drawings and plan views of all decks. Appendix B is the documentation of all input data that comprises the baseline data set. This information was collected during the ship visit and determined from a review of the COR and ship's drawings. Appendix C contains the detailed output results from running the individual target option as well as the barrier and path options on potential rooms of origin. Appendix D contains tables of various input data that were used to perform the preliminary baseline analysis but which were subsequently changed due to the information collected during the JUNIPER ship visit. Appendix E includes the complete fire protection doctrine developed for the WLB (R) class based on information pertinent to the CGC JUNIPER.

2. SHIP FIRE SAFETY ENGINEERING METHODOLOGY

2.1. INTRODUCTION

The overall fire safety of a ship is not obvious. It is dependent upon many factors, including the vast number of fire scenarios that are possible. Furthermore, a ship is actually a fire safety system, because it demonstrates performance in all phases of the life cycle of fire from prevention through detection, containment, and extinguishment. To perform a fire safety analysis, a means is required to evaluate a ship's response to fires as a fire safety system. The analysis should be able to show how the fire safety system would perform if various alternatives such as better fire boundaries, improved fire detection, or more effective manual firefighting techniques were used. In other words, a means of modeling fires on ships is required which accounts for all the relevant aspects of fire and firefighting in an integrated framework. The Ship Fire Safety Engineering Methodology (SFSEM) provides this integrated framework. The following sections furnish an overview of some of the more important features of SFSEM and its implementing computer program, Ship Applied Fire Engineering (SAFE). The SFSEM and SAFE are discussed in detail in documentation available at the Coast Guard Research and Development Center in the Safety and Human Resources Division Library. [2, 7]

2.2. SFSEM OVERVIEW

2.2.1. SFSEM FRAMEWORK

The ship, as a fire safety system, refers to the performance of a ship in all relevant aspects of fire from preventing fires in the first place, to responding to the flames and smoke produced from fires. In addition, the ability of passengers and crew to escape from a fire and the inherent ability of the ship's structure to withstand the fire's assault are also relevant considerations of a ship as a fire safety system. The SFSEM is designed to provide a comprehensive analysis of all aspects of the ship's performance as a fire safety system. It is designed in a modular fashion so that each of these considerations can be studied in isolation and so that the completed modules of the methodology can serve a useful purpose while others are being developed. The complete SFSEM consists of six modules categorized as shown in Table 2.1.

Table 2.1 SFSEM Modules

Performance Identification Module
Establish Fire Safety Objectives (FSOs)
Engineering Analysis Modules
Prevent Established Burning (EB)
Flame Movement
Smoke Movement
People Movement
Structural Frame

The Establish FSOs, Prevent EB and Flame Movement modules are incorporated in the current version of SFSEM [2]; the other three modules are under development at the present time or will be developed in the future. The following sections provide an overview of these six individual modules.

2.2.2. ESTABLISH FIRE SAFETY OBJECTIVES

In order to analyze the performance of a ship as a fire safety system, there must be acceptable performance standards or criteria established by authorities knowledgeable of fire protection engineering principles and practices. These criteria are referred to as Fire Safety Objectives (FSOs). Ideally, FSOs are established by cognizant authorities taking into consideration life safety, property protection and mission impairment. Cognizant authorities in the Coast Guard are the appropriate program and support managers in Coast Guard Headquarters. In the absence of such input, FSOs are established by the engineer/analyst using the process described in this section.

FSOs are designed to establish the performance standard for a fire safety system taking into account all aspects of fire including flame movement, smoke movement, people movement (egress for the occupants), and the ability of the structure to withstand the fire's assault. In the SFSEM, smoke movement, people movement, and structural analysis modules are not yet fully developed, therefore the FSOs are presently established considering flame movement only.

FSOs were established for the WLB (R) for each compartment utilizing the so-called traditional approach. It is the approach used over the past eight years in the fire safety analysis of twelve classes of Coast Guard Cutters. A number of limitations and drawbacks have been identified with the traditional approach, and there has been some discussion concerning the practicality and validity of establishing FSOs on a compartment basis. [17, 18] Even with these concerns, the traditional approach has merit and is considered valid. A Fault Tree Analysis (FTA) approach to establish FSOs is currently under development but is not yet available. The following paragraphs describe the traditional approach in more detail.

FSOs are established for each compartment in the cutter that may be analyzed by SAFE. Currently, magazines, flammable liquid tanks, and helicopter hangars are not analyzed due to the inability of SAFE to deal with explosion hazards. All other compartments are rated for both Magnitude of Acceptable Loss (MAL) and Frequency of Acceptable Loss (FAL). The MAL is established by assigning a rating to each of the following four factors for each compartment and then weighting these factors to determine an overall rating for the compartment:

- Life Safety (LS)
- Property Protection (PP)
- Primary Mission (PM)
- Secondary Mission (SM)

The weighting factors are different for each module in the SFSEM. For example, in the flame movement module, damage from flames affects the primary mission of the ship more than it causes life safety concerns. Whereas considering the effects of smoke, life safety will be the primary concern compared to the property damage. Thus the weighting factors for the four

factors are adjusted for each module in the SFSEM. The weighting factors used to assign a MAL rating to each compartment in the WLB (R) considering flame movement only are shown in the following expression:

$$\text{MAL} = 0.1 \cdot \text{LS} + 0.3 \cdot \text{PP} + 0.4 \cdot \text{PM} + 0.2 \cdot \text{SM}$$

The MAL rating for each factor is permitted to be one of the following four integer values:

1. Established Burning (EB) is not acceptable
2. EB is acceptable but Full Room Involvement (FRI) is not
3. FRI is acceptable but Compartment Burnout (CBO) is not
4. CBO is acceptable

A MAL rating is assigned to each factor for each compartment, then the overall MAL rating is calculated according to the algebraic expression shown above and the truncated MAL rating is assigned to the compartment. For example, if the results of the calculation is 3.37, a MAL of 3 is assigned.

The ratings are assigned for each factor using engineering judgment and considering the effect flame movement has on each factor. Compartments whose total loss (CBO) would not significantly affect the ship's primary or secondary mission are typically assigned a rating of 4 for factors PM and SM. For example, most sanitary spaces, gear lockers, passageways, voids, water tanks, ladders, cofferdams, and certain storerooms, if totally lost, would not prevent the ship from performing its primary or secondary mission. Note, a compartment may contain a significant fuel load and contribute materially to the spread of a fire, but if its loss does not significantly affect the ship's mission, it receives a rating of 4. At the other extreme, flammable materials storage lockers, paint lockers, and other compartments containing extremely flammable materials representing a significant fire hazard are normally assigned a rating of 1 for the factors PM and SM.

The balance of the compartments are normally assigned a rating of 2 or 3 for the factors PM and SM. In general, if the compartment contains equipment vital to the ship's primary or secondary mission, and if its loss would likely result in the ship aborting its patrol and returning to homeport for repairs, it would be assigned a 2. On the other hand, if the compartment's loss would degrade but not prevent the ship's ability to perform its mission, it would receive a 3 rating. Examples of compartments typically rated 2 for the factors PM or SM are the Engine Room, Bridge, and Galley. Berthing Areas, Ship's Offices and Labs/Workshops are typically assigned a 3 rating for the factors PM and SM.

A compartment's cost to replace is the primary consideration for assigning a rating to the property protection (PP) factor. Obviously, Engineering Spaces such as the Engine Room, Emergency Generator Room, Auxiliary Machinery Rooms contain very expensive machinery not only from an acquisition point of view but the costs involved in the labor to install and align the equipment is significant as well. Thus these spaces are typically assigned a rating of 2 for the PP

factor. A rating of 1 is assigned for those spaces such as paint lockers and flammable materials storage lockers for the PP factor due to their potentially rapid fire growth which would consume their contents. A rating of 4 is assigned for the PP factor to those spaces whose total loss would be considered minimal (compared to other spaces). Finally, a rating of 3 is assigned for the PP factor to those compartments whose cost is not minimal but is considered far less than major engineering spaces. Examples of spaces assigned a 3 rating for the PP factor include the Galley, Scullery and spaces with some minor machinery such as sewage machinery spaces and potable water equipment rooms.

Ratings for the life safety (LS) factor take into account the likelihood that personnel will be injured by the fire (not the smoke or toxic gases). This probability is affected by the likelihood that the space will be occupied, the accessibility of the space, the quantity of personnel likely to be in the space, and the likelihood that the occupants will be sleeping. Thus spaces such as the Paint Locker where personnel would be in danger even if EB occurs are assigned a rating of 1 for the LS factor. If EB can occur but personnel are not likely to be in serious danger unless FRI occurs receive a rating of 2 for the LS factor. If FRI can be tolerated but the entire compartment would have to be lost before personnel are in danger of being injured, a rating of 3 would be appropriate for the LS factor. Finally, if a compartment can be totally lost and still not endanger personnel, a rating of 4 can be assigned to the LS factor. After a rating has been assigned to all four factors the overall MAL rating for the compartment is calculated. This value is then used in the calculation for the FAL as described in the next paragraph.

The FAL is coupled to the MAL. For example, it may be considered acceptable to lose a compartment with a MAL = 4 once a year but compartments with a MAL = 1 may be lost only once in a ship's lifetime (30 years). Based on MAL and FAL ratings established by engineering judgment for similar compartments in several classes of cutters, a correlation between MAL and FAL was determined by fitting a curve to the data points. The following algebraic relationship expresses this correlation and is now used to establish the FAL based on the MAL rating for each compartment:

$$FAL = 32.25 - (1.766 * MAL) - (0.214 * MAL^2) - (0.222 * MAL^3)$$

The FSOs established for the WLB (R) using the traditional approach described above are tabulated in Appendix B in Table B.3.

2.2.3. ENGINEERING ANALYSES MODULES

Engineering analyses comprise the other five modules in the SFSEM. Prevent EB is designed to analyze the actions taken to prevent a fire from occurring in the first place, as well as the initial actions taken by a person discovering a fire in its incipient stage. Flame Movement, Smoke Movement, People Movement, and Structural Frame are modules that analyze the ship's ability to respond to a fire that has reached EB. Each of these analyses is designed to provide information that will allow a comparison of the ship's performance relative to the established FSOs. The following sections provide an overview of each of these modules.

2.2.3.1. Prevent Established Burning Module

In fire protection engineering terms, Established Burning (EB) defines the point when radiation feedback to the fuel bed begins to dominate as the heat transfer mode and the heat release rate of the pyrolyzing fuel may rapidly increase if proper conditions for combustion exist. From a layman's perspective, it is the smallest flame one would worry about. For example, a cigarette lighter flame would be of concern in a compartment such as a paint locker, but a flame would have to be considerably larger to be a concern in a cargo hold. The specific fire size that defines EB can thus range in size from a spark to a flame height of four feet or more. A ten inch high flame is commonly accepted as the smallest flame on a ship that constitutes EB.

The probability that EB will occur is equivalent to the probability that fire prevention (in its broadest sense) failed. The probability of EB can be calculated by multiplying the probability of ignition times the probability that the fire will grow to the critical size defined as EB. Calculating this probability is primarily useful in a study of the fire prevention phase, however, it is also used in the calculation of the probability of limiting flame spread.

The Prevent EB module analyzes the probability of EB occurring in a compartment. There are two basic approaches to accomplish this analysis. The first approach calls for evaluating the probability of each event that would lead to EB including overheating, ignition, and growth from ignition to EB. The other approach is simply to analyze historical records if sufficient data exists.

Fire safety analyses of Coast Guard Cutters to date have utilized historical records to establish the frequency of EB since adequate data from the U.S. Naval Safety Center and U.S. Coast Guard Headquarters is available for each type of compartment aboard a cutter. Military ships, including Coast Guard Cutters, are required to report all fires that result in damage or personal injury. This provides the opportunity to utilize historical records to determine the frequency of EB. Historical data does not involve the subjective judgment required in determining probabilities. Therefore the alternative "Frequency of EB" is utilized in the SFSEM.

Historical reports of fires on all classes of Coast Guard Cutters was obtained from the Commandant (G-KSE-4), U.S. Coast Guard, for the period 1984 through 1992. This data was combined with data received from the U.S. Naval Safety Center on 21 classes of large naval vessels during the period 1975 through 1986 to refine the reported fire frequencies. For the purposes of the SFSEM, similar compartments were grouped by compartment use indicator (CUI). CUI categories were adapted from the standard nomenclature used by the Coast Guard and Navy to identify compartment usage. Some CUIs were further subdivided in order to reflect a more accurate assignment of reported fire frequency. Based on experience, it is estimated that approximately half of all fires which reach EB do little or no damage to the vessel and result in no injuries to personnel; thus they are unreported. As a result, the "reported frequency of EB" based on historical data was doubled and called "adjusted fire frequency" to account for unreported fires. The number of fires reported and adjusted fire frequency values from the combined Navy and Coast Guard data is shown in Table 2.2 grouped according to CUI.

Note that the Main Propulsion Mechanical (EM) and Emergency Auxiliary Generator Rooms (QE) exhibit adjusted fire frequencies which are orders of magnitude greater than other compartments. This fact has a substantial impact on the results of a fire safety analysis using the SFSEM.

The data provided by the Commandant (G-KSE-4) was also analyzed to obtain information such as the frequency that arson is a problem, the frequency of fires that spread to other compartments from the room of origin, the class of fires that most frequently occur, the type of compartment where high dollar loss fires occur, etc.

Table 2.2 Fire Frequency Data

Type of Compartment	Compartment Use Indicator (CUI)	Number of Fires Reported	Adjusted Fire Frequency (1) (Fires per Compt Year)
Cargo Hold	AA	0 (2)	0.0001 (3)
Gear Locker	AG	19	0.0010
Refrigerated Storage	AR	3	0.0009
Storeroom	AS	34	0.0009
Ship Control Area	C	4	0.0012
Main Propulsion Electrical (4)	EE	7	0.0031
Main Propulsion Mechanical	EM	148	0.0272
Fuel Oil, Lube Oil Tank	F	0 (2)	0.0001 (3)
JP-5 Fuel Tank	J	0 (2)	0.0001 (3)
Hazardous Material Storage	K	4	0.0013
Berthing Space	L1, L2, L5	20	0.0008
Wardroom, Mess, Lounge Space	LL	7	0.0008
Medical, Dental Space (4)	LM	0	0.0001
Passageway, Staircase, Vestibule	LP	3	0.0001
Sanitary Space	LW	4	0.0002
Explosives Storage	M	1	0.0001
Auxiliary Machine Space (4)	QA	89	0.0029
Emergency Aux. Generator Room (4)	QE	23	0.0204
Fan Room	QF	7	0.0004
Galley Pantry, Scullery	QG	13	0.0026
Helicopter Hangar	QH	3	0.0036
Laundry	QL	5	0.0031
Office Space (4)	QO	5	0.0004
Shops, Labs	QS	15	0.0018
Trunk, Hoist, Dumbwaiter	TH	0 (2)	0.0001
Stack, Uptake	TU	5	0.0013
Void, Cofferdam	V	1	0.0001 (3)
Water, Peak, Ballast Tank	W	1 (2)	0.0004

NOTES:

1. Taken as twice the reported fire frequency
2. Based on 1986 - 1991 USCG data only. (All other numbers of fires based on both USN and USCG data.)
3. Default value used in cases where no fires have been reported, or when calculated adjusted frequency is below 0.00005
4. New compartment types added since analysis of first three small cutters in the SCFP project

2.2.3.2. Flame Movement Module

If a fire grows beyond EB, the goal of shipboard firefighting is to limit the spread of the fire to the room of origin. If the fire breaches the compartment boundaries (or barriers) in the room of origin, the fire may spread to involve adjacent compartments. Thus, from the perspective of flame movement, fire spreads from compartment to compartment by attacking and destroying the barriers separating the compartments. Fire will continue to spread if there is adequate fuel and oxygen to sustain fire growth. The SFSEM first evaluates the probability of extinguishing the fire in a room of origin; then it considers the probability of the compartment barriers successfully limiting the fire from spreading to adjacent compartments. Finally, it evaluates the probability of extinguishing the fire in the adjacent compartments, then the adjacent compartment's barriers are evaluated and so on. This process is repeated for every possible room of origin and every possible fire path until the probability of limiting the fire is 1.0 (100%) or until the user-specified time has elapsed, whichever comes first. Results are accumulated for each compartment as a target of fire and compared to FSOs. The results identify areas where fire protection systems need to be improved, and where they can be reduced and still achieve desired levels of fire protection. A key assumption in the SFSEM is that stoichiometric burning conditions exist. This conservative assumption assures that worse case conditions are considered in the analysis. In the flame movement module of the SFSEM probabilities are determined based on engineering judgment or degree of belief of the analyst. While the methodology is fundamentally probabilistic, certain aspects in fire science lend themselves to deterministic solutions. Deterministic algorithms are incorporated wherever sufficient data exists to validate them. The philosophy also considers the fact that the human mind is limited in the number of factors it can integrate simultaneously. The framework of the SFSEM breaks all events into smaller subevents so that the analyst can focus his or her engineering judgment on relatively few factors, while the computer programs carry out the extensive calculations necessary to aggregate the results.

2.2.3.3. Smoke Movement Module

Fires produce smoke and toxic gases as products of combustion. In addition, certain firefighting agents such as Halon may create toxic gases in the process of extinguishing the fire. Other extinguishing agents such as CO₂ significantly reduce available oxygen. Carbon monoxide, in particular, is extremely lethal; CO is a product of combustion and is produced regardless of the extinguishing agent used. The obscuration from the smoke and the untenable atmosphere from toxic gases more often result in a life-threatening situation than the flames themselves. An analysis of the smoke movement in a fire is therefore vitally important in determining the ship's performance relative to life safety objectives. Unfortunately, the analysis of smoke movement in a ship with its installed ventilation systems is extremely complex. Considerable research has been devoted to smoke movement by fire protection engineers in the academic as well as research and development communities. The smoke movement module should be the next module integrated into the SFSEM.

2.2.3.4. People Movement Module

In the event of a fire emergency on a ship, passengers and off-duty crew have to proceed to areas of refuge. On-duty crewmen in certain spaces such as the Bridge and Engineering Control Center cannot evacuate due to the need to operate the ship's propulsion and navigation

systems. In wartime, battle stations also remain occupied during a fire due to the need to defend the ship and operate the ship's weapons systems. Consequently, certain compartments require fire protection systems adequate to protect occupants who cannot evacuate for one reason or another. The people movement module will be designed to analyze egress routes to areas of refuge and evaluate the adequacy of fire protection systems for defending people in place. This module should be developed and integrated into the SFSEM in the future.

2.2.3.5. Structural Frame Module

Watertight bulkheads and decks on ships provide the necessary segregation for adequate protection against progressive flooding. The watertight compartments thus created are further subdivided with non-structural bulkheads to provide segregation of ship functions and accommodate the ship's missions. Most watertight boundaries in ships are steel to provide the necessary structural strength to resist the hydrostatic forces that may be encountered due to progressive flooding. The structural collapse of steel bulkheads and decks in the first hour or so of a fire is unlikely. However, some ships such as hydrofoils, fast patrol boats, surface effect ships and other weight-critical vessels are constructed of aluminum. This material loses structural strength at relatively low temperatures compared to steel. The structural frame module is intended to analyze the effects of fire on the structural members of the ship. This module should also be developed and integrated into the SFSEM in the future.

2.2.4. SFSEM APPLICATIONS

The flame movement module of the SFSEM is a probabilistic-based risk analysis methodology. This means that the results are based primarily on probabilities determined by engineering judgment of the engineer/analyst as opposed to deterministic calculations of conditions precisely known. Therefore, the results are the most useful when the analyst uses the methodology to compare outcomes on a relative basis. Analyzing competing preliminary designs to identify the best design with respect to fire safety is an example of such a potential application. It is also appropriate to compare, on the same ship, the effectiveness of different fire protection alternatives.

The SFSEM has been used in the past to analyze the preliminary fire safety design of the Polar Icebreaker Replacement (PIR) and the WLM(R). It has also been used extensively in the SCFP to analyze the fire safety design of nine classes of active small U. S. Coast Guard Cutters. Prior to the WLB (R) project, the most recent application was the analysis of the VINDICATOR after conversion to a Coast Guard Medium Endurance Cutter. It has been demonstrated therefore that the SFSEM has utility to analyze proposed, as well as existing, fire safety designs of ships. The following sections describe the past as well as potential future applications for the SFSEM.

2.2.4.1. Fire Safety Design Analysis

The SFSEM permits an evaluation of individual fire protection components within a ship. It can compare alternative fire protection measures against a baseline or in a relative sense to each other. The basic flowchart for this process is illustrated in Figure 2.1. The SFSEM can be used to compare alternative fire protection components that are in the same category such as evaluating the effectiveness of different firefighting agents. Its true value, however, lies in its ability to compare heretofore incomparable entities such as evaluating the relative effectiveness of

a barrier and a firefighting technique. This sort of comparison is especially useful to answer “what-if” questions often raised by decision-makers. Note that actual or proposed components can be evaluated on actual or proposed ships. Furthermore the SFSEM and the reports generated by SAFE provide the necessary documentation to support a serious study of the fire safety levels of these vessels.

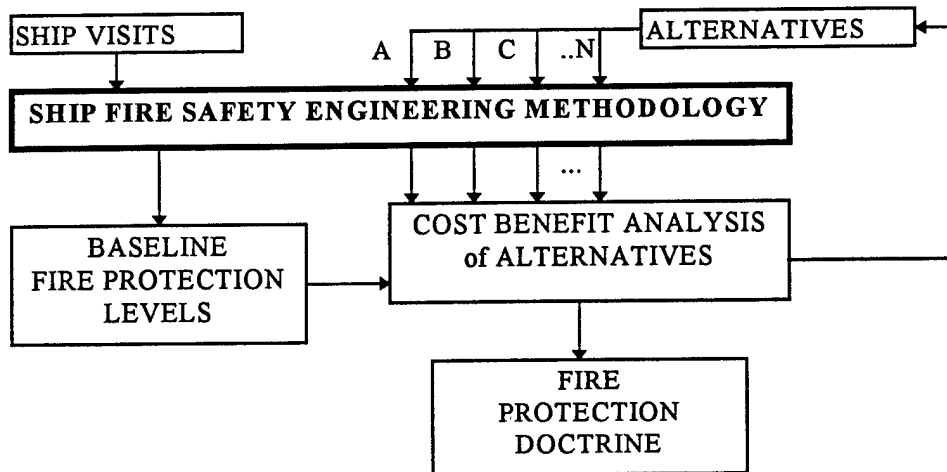

Figure 2.1 Role of the SFSEM in Fire Safety Design Analysis

2.2.4.2. Fire Investigations

The focus of fire investigations is usually a search for the cause or origin of the fire and frequently includes an investigation for negligence or dereliction of duty. Certainly, the loss of valuable property and lives warrants an investigation and a determination of responsibility, but the performance of the ship as a fire safety system is often overlooked. Moreover, there has been a lack of analytical tools with which to assess this performance. The SFSEM is not the proper tool to conduct a forensic type of fire reconstruction analysis. There are deterministic computer fire models which are more appropriate for this type of analysis. However, the SFSEM can be used to analyze the possible fire paths compared to the actual fire paths to gain insight into the ship’s response to the fire. Furthermore, most ships are one vessel in a class of similar ships. An analysis of a fire may yield valuable information which would benefit the rest of the class.

2.2.4.3. Future Applications

In the future, the SFSEM may be used for equivalency determinations. The SFSEM provides the ability to quantify the contribution of fire protection features such as passive, automated, or manual firefighting features to achieve FSOs. Therefore, the means exist to verify an equivalent feature. For example, installing an automated fire protection system such as sprinklers may be determined equivalent to the passive fire protection currently provided by the existing watertight boundaries which act as fire boundaries. The SFSEM does not take into

account flooding, therefore removing an existing bulkhead may be compensated by installing the sprinkler system for the purposes of fire safety, but flooding the "larger" compartment thus created may result in the ship sinking. The SFSEM only considers fire safety related issues.

The effectiveness of damage control teams in response to shipboard fires varies considerably from ship to ship. Even within a ship, the response can vary between daytime and nighttime and especially over a period of time following firefighting team training. Moreover there is a significant difference in the size of the crew available to respond to a fire between in port and at sea conditions. The evaluation of the time between initial notification of the Bridge and the agent application is one of the significant variables. This variable could be used as the basic standard of measurement for damage control firefighting teams. Evaluation of this base measure, compared with other measures of firefighting agent delivery, can provide evaluation of levels of fire protection for different compartments within the ship or a comparison of different ships within the same class. This would serve to point out areas where damage control training was deficient. The SFSEM could also be used in a similar manner to evaluate the effectiveness of the ship's fire protection doctrine.

2.3. SAFE OVERVIEW

2.3.1. SAFE FRAMEWORK

SAFE is a programming system that automates portions of the SFSEM. It is actually an integrated series of programs requiring engineering evaluations, ship geometry, and ship features as input. SAFE employs both AutoCAD and an external database in order to organize the large amounts of data required to perform a fire safety analysis, to provide a user-friendly and manageable means of data entry, and to display the results in a meaningful manner. SAFE enables a person to describe the layout of a ship through AutoCAD, enter data values for compartments and barriers into a database, and run a probabilistic fire model on a ship. These data values, as well as results of running the probabilistic model, can be output in tabular and/or graphical form. The SAFE User Manual provides the details necessary to use SAFE to conduct a fire safety analysis on a ship. [7] Version 1.0 was used in the PIR study. Versions 2.0, 2.1 and 2.1A were used to analyze the ten classes of small cutters. Version 2.2 was used to analyze the VINDICATOR and the WLB (R). The analyst should be a fire protection engineer with shipboard experience.

2.3.2. AUTOCAD

SAFE requires an accurate representation of the ship's geometry in order to determine connectivity between compartments and thus predict fire growth through these compartments. To provide this geometry, the coordinates of the corner points ("vertices") of each compartment's deck, the compartment elevation, and the compartment height are needed. SAFE utilizes AutoCAD as a tool for drafting a simplified version of the general arrangement deck plans of the ship so this information can be obtained. AutoCAD is also used to tailor default values assigned by the database and to display graphic results of the analysis.

2.3.3. DATABASE

The database is loaded, using information from the AutoCAD drawing and database entry screens, with all the values it needs to run the probabilistic model. General ship information is entered through a database screen, then the ".dxf" (drawing exchange format) files created in AutoCAD are used to calculate the ship geometry. Once the ship geometry is complete, information from the ship visit forms are entered. Certain fire parameters are assigned default values. AutoCAD permits tailoring these default values. Database reports are available to display fire parameters assigned to each compartment and barrier.

2.3.4. PASCAL PROGRAMS

Integrated into SAFE are numerous Pascal programs which provide three critical functions of the SFSEM:

- **Connectivity Generation.** Based on the AutoCAD drawings, SAFE determines the connectivity between compartments. Specifically, it determines which segments of bulkheads and decks are in common between compartments. Modelling this correctly is important because the SFSEM relies on the principle that fire spreads from one compartment to another by attacking and destroying the barriers between compartments.
- **FRI Time and Heat Release Rate Calculations.** The FRI time algorithm utilizes the Beyler-Peatross algorithm. [19] The coefficients for this algorithm are based on full-scale shipboard testing at the USCG Fire and Safety Test Detachment in Mobile, Alabama. The post-FRI heat release rate calculation is based on compartment ventilation assuming "worst case" stoichiometric burning (adequate oxygen to support combustion of all available fuel).
- **Probabilistic Modeling.** A run of the fire model begins with a compartment which has experienced ignition and fire growth to the point where the fire size meets the definition of "EB". At the point when EB is reached, the clock is set to time 0 (minutes) in the compartment referred to as the room of origin. The fire is allowed to grow until FRI is achieved in the room of origin or until the flames are limited by passive, automated or manual means prior to FRI. The variables in the equation that describes fire growth in the pre-FRI fire growth regime are explained in the Theoretical Basis of the SFSEM. [2] If FRI is achieved; however, the model then calculates and accumulates the heat energy impact on the barriers in the room of origin and determines the probability of failure for each barrier from the catalog of Tbar and Dbar curves for barrier materials. Heat energy impact is calculated in the post-FRI fire growth regime according to the model for heat release rate assuming stoichiometric burning. If a barrier failure occurs, EB is established in the adjacent compartment and the fire growth cycle is started again. This space-barrier progression is allowed to continue until the fire is limited or until a predetermined, user-specified time has elapsed. In this space-barrier propagation, the probabilistic model builds a set of fire paths from each possible room of origin and accumulates results so that the compartments may be rank ordered in their performance as "targets" of the fire compared to the established FSOs.

2.3.5. COMPARISON OF SAFE VERSIONS 2.1A AND 2.2

Version 2.2 of SAFE was used in the analysis of the VINDICATOR and the WLB (R). This version contains many improvements over versions 2.1 and 2.1A which were utilized in the

SCFP. The majority of these improvements deal with making SAFE easier and more flexible to use, but several changes, which are outlined below, may affect the results of a fire safety analysis.

- An option was incorporated into the probabilistic model which allows a flammable liquid line rupture (FLLR) to be simulated. This option allows a scenario to be created whereby a user-specified engineering compartment is selected as the room of origin experiencing a FLLR. Its I value, FRI time, and liquid fuel load may be modified by the user to more accurately reflect the increased probability of fire propagation associated with a FLLR scenario.
- The user was given the ability to adjust FRI times for individual compartments. In prior versions, if a user was dissatisfied with any compartment's calculated FRI time, he or she could only adjust input values and recalculate FRI time. With version 2.2, the calculated FRI time itself may be adjusted.
- The probabilistic model's barrier option was altered to allow the user to focus on which compartments are the most problematic as compartments of fire origin. It shows an ordered list of barriers in the room of origin sorted by those with the highest probability of failure given EB and a second list of the same barriers sorted by those with the highest frequency of failure given Fire Free State (FFS).
- The frequency of EB in Medical and Dental Spaces (CUI=LM) was changed from 0.0004 to 0.0001 fires per compartment year. No fires on Coast Guard cutters have been reported in these spaces over the eight year period of time when frequency data was tabulated. None of the ships analyzed using SAFE 2.1 and 2.1A had Medical and Dental Spaces, so this frequency change had no impact on prior analyses.
- Qmax values for fire growth models 1-6 and 8-10 were improperly calculated in SAFE versions 2.1 and 2.1A. This was corrected in version 2.2 and generally resulted in slightly lower Relative Loss Factors in target compartments.
- The formula for converting gallons of flammable liquid fuel to an equivalent amount of cellulose in pounds was increased from 6.8 pounds per gallon to 8.0 pounds per gallon. This represents the conversion for fuel oil which is the predominant liquid fuel on board Coast Guard cutters.

2.4. FIRE SAFETY ANALYSIS PROCEDURE

A fire safety analysis is conducted in the following phases:

- Preliminary Fire Safety Analysis. A preliminary analysis is conducted and documentation is collected in conjunction with a visit to the ship when possible. Information required to run the computer programs associated with the SFSEM is also collected and verified during this stage.
- Detailed Fire Safety Analysis using SFSEM/SAFE. The SFSEM and its implementing computer programs, SAFE, are used to perform a detailed fire safety analysis of existing "baseline" fire protection levels and to study hypothetical changes to the fire safety design of the ship.

The following sections will address various aspects of the process used to analyze cutter fire safety.

2.4.1. PRELIMINARY FIRE SAFETY ANALYSIS

Information required to conduct a preliminary fire safety analysis is collected during the ship visit. The ship visit has the following specific purposes as explained in the Theoretical Basis of the SFSEM [2]:

- Conduct fire safety audit
- Collect detailed information to accomplish the fire safety analysis using the SFSEM/SAFE
- Collect and review all relevant documentation concerning firefighting procedures
- Observe fire drill

The fire safety audit is conducted to identify existing passive and active fire protection features and procedures, determine fuel loads and any unusual fire hazards, and to evaluate the accessibility of compartments for firefighting and egress routes for personnel. When possible, a fire drill is observed to assess the characteristic time it takes to set ZEBRA and to enable the analyst to assess manual firefighting effectiveness. The cutter's Main Space Fire Protection Doctrine, Casualty Control Manual, Compartment Check-off Lists, and Repair Locker Inventory and other critical information regarding the cutter's firefighting procedures is collected and reviewed. The results of this review are organized according to the phases in the life cycle of a fire commencing with prevention, and proceeding through detection, containment, and extinguishment. These four phases are discussed in the following sections.

2.4.1.1. Prevention

The four basic principals of fire prevention which should be observed routinely to reduce shipboard fires are:

1. Frequent inspections
2. Proper stowage of combustibles
3. Training and education
4. Enforcement of fire prevention policies and practices such as good housekeeping

The fire prevention phase also includes first aid or the initial attempts to extinguish a fire after ignition occurs but before the fire grows substantially beyond the point described as EB. The ship is examined for adherence to the four principals described above and to identify procedures and equipment the ship routinely uses for first aid.

2.4.1.2. Detection

There are two ways a fire can be detected on board ship - by a crew member or by an installed monitoring device. As the proposed crew levels decrease with the minimal manning concept, it becomes more important to install sophisticated and comprehensive fire detection systems to ensure early detection of fire while the fire is small and more amenable to extinguishment. Moreover, fire grows exponentially with time, and it is significantly easier to extinguish a small fire compared to a large fire. All compartments are checked for the presence of required monitoring devices. A spot check of the operating condition of smoke detectors is

accomplished if possible. The ship's watch quarter and station bill is reviewed to help determine manning levels in compartments during various operating conditions.

2.4.1.3. Containment

If a fire grows beyond EB, it is desirable to contain the fire within the room of origin to minimize the damage. Containment of a fire can be accomplished through passive or active means. Passive measures include adequacy of compartmentation, use of non-combustible construction materials, and control of quantity, type and distribution of fuel loads. Active measures include setting condition ZEBRA and securing ventilation, fuel and electrical power in the affected spaces. All bulkheads and decks which serve as barriers to contain the fire are examined to determine their adequacy for this purpose. The location of isolation valves, remote shutdowns, and fire dampers is also observed and noted.

2.4.1.4. Extinguishment

Extinguishment requires appropriate firefighting equipment in strategic locations, adequate protective equipment and clothing for firefighters, and personnel adequately trained to operate the equipment and work as a team. Firefighting equipment includes both manually operated and automatic/automated systems. Protective equipment and clothing include emergency escape breathing devices, oxygen breathing apparatus (OBA), firefighting ensembles, flash gear, etc., and hand held detection devices such as firefinder or the naval firefighting thermal imager (NFTI). The ship is thoroughly inspected to identify the location, type, size and number of firefighting equipment onboard. The damage control lockers are inspected for contents and the fire protection doctrine reviewed. The state of crew training in firefighting procedures is also ascertained, if possible.

2.4.2. DETAILED FIRE SAFETY ANALYSIS

A nine step procedure for conducting a detailed fire safety analysis using the SFSEM/SAFE has been developed and refined over the course of conducting previous analyses. Prior to conducting the analysis, it is necessary to obtain the ship's general arrangement drawings in AutoCAD. This may require a preliminary ship visit to obtain the information necessary to properly model the ship's geometry. Since most ship drawings are in the form of paper copies, as opposed to AutoCAD renditions, it is usually necessary to create the AutoCAD drawings from paper copies. Once the ship has been modeled in AutoCAD, the following procedure is used to perform a complete fire safety analysis:

1. Load Database With Ship's Geometry
2. Conduct Ship Visit
3. Load Safe Input Value
4. Calculate FRI Times and Post-FRI Heat Release Rates
5. Run Probabilistic Model
6. Analyze Baseline Results
7. Analyze Fire Protection Alternatives

8. Conduct Cost-Benefit Analysis

9. Document Results

These steps are discussed in the following sections.

2.4.2.1. Load Database With Ship's Geometry

The simple, yet accurate, representation of the ship's geometry created in AutoCAD is utilized by SAFE's connectivity generator to produce a listing of all compartments on the ship. Also produced is a listing of each compartment's barriers which connect them to other compartments or to the weather. Once these lists have been verified for accuracy, they are loaded into SAFE's database and ship visit forms are produced.

2.4.2.2. Conduct Ship Visit

The SFSEM/SAFE requires an extensive amount of data to facilitate an analysis of the cutter's fire safety. Preprinted ship visit forms ensure information concerning fuel loads, compartmentation, ventilation, FSOs and other required data is collected in an efficient manner. This information is also used by the engineer/analyst to temper the engineering judgment required to develop the probabilistic values entered into SAFE.

It is essential that the engineer/analyst personally visit the ship. During the ship visit, the engineer/analyst:

- Completes the ship visit forms and verifies the accuracy of all information on the preprinted forms.
- Photographs compartments to document fuel loads, unusual fire protection features, accesses, egress routes, ventilation openings, etc.
- Ideally, observes an "in port" fire drill and notes the time to set condition ZEBRA. If it is impractical to observe an actual fire drill, the characteristic time to set ZEBRA may be obtained from the ship's records.
- Obtains copies of the ship's main space fire doctrine, casualty control manual, and compartment check-off lists if these documents were not previously collected.
- Discusses with the Commanding Officer and Operations Officer the various missions of the ship and which compartments contain equipment which supports these missions. This information aids in establishing realistic fire safety objectives (FSOs).
- Discusses with the Engineering Officer and Damage Control Assistant (DCA) the state of the crew's firefighting training. In addition, the general condition of the ship (whether it is well maintained and clean or not), and the overall attitude and sense of pride in the ship the crew displays is noted. This information is used in the determination of certain input values which are assigned by engineering judgment.

The quality of the fire safety analysis is directly proportional to the quality of the information collected during the ship visit. Typical small cutter ship visits requires two working days for two engineer/analysts. Large cutters may require additional time.

An actual ship may not exist to visit and the engineer/analyst may find it necessary to work with preliminary designs of the proposed ship. In this event, the engineer/analyst should visit a similar ship (in size, design, and mission) to aid the engineer's judgment in predicting what the input values will be once the ship is built. In addition, the Circular of Requirements (COR) and information provided by the shipyard, can augment the knowledge gained by visiting a similar ship.

2.4.2.3. Load Safe Input Values

This step includes refining the ship's geometry with any new information gathered during the ship visit, determining all required fire parameters, performing the data entry of the information on the ship visit forms and verifying the accuracy of the data entry. The values now in the database comprise the "baseline data set" for the ship. This baseline data set permits discrimination from data associated with hypothetical alternatives that may be analyzed later in the analysis.

The probabilities of flame termination and barrier failure in each compartment are the key values the analyst determines based on engineering judgment. There are three ways a fire can occur in a compartment. The fire can:

1. Originate in the compartment (EB)
2. Enter from an adjacent compartment via a hot spot or thermal failure (Tbar) of a connecting barrier
3. Enter from an adjacent compartment via a massive or durability failure (Dbar) of a connecting barrier.

There are also three ways a fire can be limited or terminate in a compartment:

1. Self extinguishment (I),
2. Suppression by automated/fixed fire extinguishing systems (A),
3. Manual suppression (M).

Therefore, a 3 x 3 matrix of nine probabilities of flame termination are required to completely characterize the probability of flame limitation in each compartment. Probability is the numerical measure for expressing the likelihood of an event. The terms probability, likelihood, and degree of belief are considered to be synonymous in this context. The numerical measure of probability can vary from zero to one. A probability of zero indicates that an event will never happen, while a value of one indicates that it will always happen. A value between zero and one indicates the relative likelihood of the occurrence of the event, in this case, the probability that a fire will be limited or extinguished. Probability is often expressed as a percentage between 0 and 100, as is the case with the values shown in Table 2.3.

Table 2.3 is an example of the probabilities that are assigned to a typical engine room. This table shows that it is more likely that a fire will be limited if the fire enters the compartment as a result of a hot spot failure in a bulkhead (Tbar) than if it enters the compartment as a result of a massive failure of the bulkhead (Dbar). Moreover, it is least likely for a fire to be limited if the fire originates in the compartment (EB). Similarly, it is more likely that automated/fixed systems will limit a fire than manual firefighting efforts because these systems tend to be reliable and use

highly effective firefighting agents such as Halon 1301 or CO₂ compared to water typically used by firefighters. A fire is also more likely to self extinguish than be suppressed by manual firefighting efforts. These probabilities are assigned based on engineering judgment of the engineer/analyst tempered by the values assigned to similar compartments on other Coast Guard Cutters.

Table 2.3 Probabilities of Flame Termination in a Typical Engineroom

	EB	Tbar	Dbar
I	40	48	44
A	90	99	99
M	20	24	22

A catalog of barrier materials exists for a number of different barrier materials commonly encountered in ship construction. The catalog contains graphs which plot probability of failure versus heat energy impact for each barrier material for each failure mode (Tbar and Dbar). The key points on these curves are tabulated in Attachment B.2.1 to Appendix B. These values were determined in accordance with the procedures for establishing Tbar and Dbar curves documented in the Theoretical Basis of the SFSEM. [2]

In addition to the probabilistic values assigned to compartments and their barriers, other more deterministic values collected during the ship visit are also loaded into the SAFE database. MAL and FAL, the two components of Fire Safety Objectives as discussed in Section 2.2.2, are entered into SAFE at this time as well.

2.4.2.4. Calculate FRI Times And Post-FRI Heat Release Rates

Flashover is the sudden propagation of flames through the unburned gases and vapors collected at the top of the compartment. Flashover invariably leads to full room involvement conditions where all combustibles are surface burning and conditions are untenable for life without self-contained breathing devices and thermal protective clothing. Thus flashover and the elapsed time to FRI (FRI time) are important parameters in fire growth. After all input values have been assigned, the Full Room Involvement time (FRI time) and post-FRI heat release rates are calculated for each compartment. FRI times may be reviewed and adjusted, or input values used to calculate FRI may be adjusted and FRI may be recalculated. FRI times are calculated in SAFE in accordance with the Beyler/Peatross algorithm. [19] Basically, this algorithm calculates the time in minutes for the temperature in a compartment to rise 500 degrees Celsius above ambient. This elapsed time is referred to as FRI time. The major variables include the pre-FRI heat release rate of the burning fuel, the heat lost through the barriers and the incoming air. The coefficients for this algorithm were determined from full-scale ship fire tests conducted at the U. S. Coast Guard Fire Safety Test Detachment, Mobile, AL.

The variables in the post-FRI heat release rate calculation are included in the ventilation factor: $A \cdot H^{0.5}$. This factor takes into account the height and area of a single vertical ventilation

opening which is providing natural (unforced) ventilation. The coefficient for this variable is based on the worst-case assumption of stoichiometric combustion. Some ship compartments are served by multiple vents and frequently use forced ventilation through horizontal vents; thus, determining vent opening height becomes problematic. An appropriate post-FRI heat release rate deterministic algorithm, validated by full scale ship tests, is one of the areas of improvement needed in the continuing development of the SFSEM.

2.4.2.5. Run Probabilistic Model

Once the database has been loaded with all required input, the probabilistic model is run on the baseline data set to establish the baseline fire safety levels of the ship. Several parameters have to be specified in order to run the model. These parameters are specified in "scenarios". Standard scenarios include conditions normally encountered on board ship, whereas non-standard scenarios permit altering these conditions to permit a more robust analysis. A more detailed discussion of scenarios is provided later in this section.

An important parameter that has to be specified in a scenario is the material condition of readiness. A cutter is typically in material readiness condition XRAY (all access closures, valves and fittings marked "X" closed) or YOKE (all access closures, valves and fittings marked "X" or "Y" closed). Condition ZEBRA (all access closures, valves, and fittings marked "X," "Y," or "Z" closed) is set only in emergencies such as fire, collision, or enemy attack. SAFE simulates the setting of condition ZEBRA during a model run after a calculated "time to detection" plus a "time to set ZEBRA" has been reached.

The ship is normally in port or at sea. In port, material condition XRAY is usually in effect during working hours, otherwise condition YOKE is set (at night and on weekends for example). At sea, material condition YOKE is normally set. Since the doors and other accesses serve a vitally important role in containing fire spread it is necessary to specify the material condition of readiness in the scenario so that the SFSEM properly models the status of the doors, scuttles, hatches, windows, etc.

A scenario in SAFE includes user-defined parameters such as material condition of readiness, ship location (at sea or in port), firefighting configuration, barrier failure criteria, simulation run time, etc. Standard scenarios are established to describe operating conditions for the cutter over the majority of its life cycle as shown in Table 2.4. A non-standard scenario specifies varying levels of fire protection in effect as shown in Table 2.5. Note that all three lines of defense are in effect (I, A, and M) in all three standard scenarios shown in Table 2.4. Certain conditions on some ships result in virtually no difference in the two in port standard scenarios or in the two YOKE scenarios. In these cases, the three standard scenarios may be reduced to two.

Table 2.4 Standard Scenarios

Scenario #	1	2	3
Configuration	X-RAY	YOKE	YOKE
Location	In-Port	In-Port	At-Sea
Fire Protection Level	I, A & M	I, A & M	I, A & M

Table 2.5 lists nine non-standard scenarios (scenarios 4 through 12) which describe "other than normal" conditions. For example, in order to evaluate the ship's response to a fire while underway without considering the contributions provided by automated (A) or manual (M) firefighting, scenario number 12 in Table 2.5 would be utilized. This scenario describes the ship at sea, under normal steaming conditions, but does not include the contributions provided by any automated/fixed fire protection systems or the manual firefighting efforts of the crew.

Table 2.5 Non-Standard Scenarios

Scenario #	4	5	6
Configuration	X-RAY	YOKE	YOKE
Location	In-Port	In-Port	At-Sea
Fire Protection Levels	I & A	I & A	I & A
Scenario #	7	8	9
Configuration	X-RAY	YOKE	YOKE
Location	In-Port	In-Port	At-Sea
Fire Protection Level	I & M	I & M	I & M
Scenario #	10	11	12
Configuration	X-RAY	YOKE	YOKE
Location	In-Port	In-Port	At Sea
Fire Protection Level	I	I	I

2.4.2.6. Analyze Baseline Results

The first step in the detailed fire safety analysis of a ship with the SFSEM is a determination of its existing fire safety. To facilitate discussion, this result is referred to as the "baseline". Baseline Data Sets reflect input values to the SAFE program which are based on the physical condition of the ship found during the ship visit and are not influenced by any modifications or alterations which may be proposed as a result of this analysis.

The baseline analysis is designed to identify compartments which fail to meet FSOs so that attention can be focused on these compartments. Ideally, multiple hypothetical alternatives are identified and studied that improve the fire safety to minimally acceptable levels. A cost-benefit analysis can then be conducted to form the basis for recommendations.

When a scenario is specified for the probabilistic model, the user may select from a variety of output options including, but not limited to:

- Individual Target Option which provides results of individual compartments as targets of fire. This option provides a rapid look at all compartments and their performance compared to fire safety objectives.
- Target Set Option which considers sets of mission-critical compartments as targets of fire. This option is also useful for analyzing the fire safety of the entire ship as a fire safety system.
- Barrier Option which provides details for plotting the probability of flame limitation in each compartment (L curve) and the probability of failure of its associated barriers. This option is useful for considering a limited number of compartments in detail.

- Path Option which provides details of all fire paths from a single room of fire origin. Unlike the target options, the barrier and path options do not normalize results compared to FSOs.

Results from all options are available as summary and detailed level reports. The individual target option results may also be displayed graphically. The individual target option has been utilized most extensively to conduct a fire safety analysis. It produces Relative Loss Factors (RLFs) for each compartment which represent a relative comparison of a compartment's frequency of loss with its FSOs.

The results of using the individual target option with the standard scenarios on the baseline data set are carefully examined to determine how well the ship performs as a fire safety system in response to a fire. This is accomplished by examining RLFs for "target" compartments. RLFs greater than 1.0 indicate the target compartment failed to meet the FSOs established for that compartment and an improvement in fire protection is needed. A target compartment with a RLF equal to 1.0 indicates the compartment meets its FSOs. A target with a RLF less than 1.0 indicates the compartment exceeds its FSOs and a reduction in fire protection may be acceptable. There are at least three possible reasons that a compartment fails to meet FSOs (more than one can apply):

- The target compartment itself lacks adequate fire protection.
- Another compartment is responsible for fires that spread and ultimately involve the target compartment.
- FSO's for the target compartment were not set properly.

Note that the results from the individual target option focus on the target compartments which do not meet their FSOs, they do not provide any insight as to the primary sources of the fires that ultimately caused the loss of the targets. Determining the source, or cause for each failed compartment may involve running the probabilistic model with different output options such as the barrier or path options. For example, the path option may yield information that many of the fire paths that ultimately involve the target compartment actually originate in another compartment. Thus improving the fire protection in the appropriate room of origin may improve the results in the target compartment as well as the room of origin!

2.4.2.7. Analyze Fire Protection Alternatives

To determine ways to improve the fire safety of compartments which fail to meet FSOs, or less typically, to determine ways to reduce fire safety in over-protected compartments, hypothetical alternatives may be efficiently analyzed in SAFE. The alternatives studied should be consistent with the goals established by the sponsor. For example, in the SCFP the sponsor's goals for the ten cutter classes analyzed were: (1) reduce the dependence on manual firefighting without a reduction in fire safety levels for the cutter and, (2) identify potential improvements to fire safety so that all compartments meet FSOs in all three standard scenarios. These goals were achieved by running non-standard scenarios (Manual Firefighting "turned off"), then modifying the baseline data set for alternatives that enhance Passive or Automated Firefighting to determine if the improvement is equivalent to the contribution provided by manual firefighting. This step can be a protracted exercise but should be continued until the goals of the analysis are achieved or until all reasonable alternatives have been analyzed.

An alternative data set modifies the parameters of the baseline data set such that it represents the conditions that would be in effect if that alternative were employed on the cutter. Baseline or alternative data sets may be analyzed in combination with standard or non-standard scenarios to consider various alternatives. Once the situation is defined by the analyst, values are assigned that numerically represent the appropriate probabilities involved. Alternatives may also be rank-ordered by RLF for their effect on fire safety (i.e. lower RLFs equate to greater fire safety).

This step usually involves analyzing alternatives to identify improvements in compartments which fail to achieve FSOs. In those cases where the baseline fire safety levels exceed FSOs by a substantial margin in all compartments, no improvements would be indicated. In these cases this step can still serve a useful purpose. For example, certain features of the existing fire safety design may be hypothetically eliminated so that the effect on fire safety can clearly be demonstrated or justify a recommendation to eliminate "over-protection". Another "alternative" may be to study certain fire safety features to achieve the sponsor's objectives. For example, the sponsor may desire to identify an equivalent barrier, or firefighting agent, even though FSOs are being achieved. Thus the effect of replacing Halon with CO₂ or AFFF could be studied to determine the effect on fire safety levels due to the fact Halon causes environmental damage.

2.4.2.8. Conduct Cost-Benefit Analysis

If multiple alternatives are identified, a cost-benefit analysis can be conducted to recommend the most cost effective alternatives. Alternatively a weight-benefit or volume-benefit analysis may be substituted depending on the sponsor's objectives. In either event, the "benefit" is quantified by the improvement in the RLFs. The "cost" should take into account the direct and indirect costs of implementing the change. For example the weight, volume or price are examples of direct costs while inconvenience to the crew, damage to the environment, or impact on other missions are examples of indirect costs.

2.4.2.9. Document Results

The final report should document the results of the baseline analysis and consideration of all alternatives. Reports from SAFE can be generated and included to provide supporting data. Graphic reports from SAFE (including color-graphics) can significantly enhance the report. For example SAFE can generate deck plans which portray compartments which fail to meet FSOs in red, while compartments colored yellow, green or blue are progressively "safer".

2.5. PREVIOUS FIRE SAFETY ANALYSES USING SFSEM/SAFE

2.5.1. POLAR ICEBREAKER REPLACEMENT (PIR)

The preliminary design of the U.S. Coast Guard PIR was analyzed using the SFSEM/SAFE in 1987. [8] This project was important for several reasons. It was the first formal fire safety analysis of a preliminary design of a Coast Guard Cutter. It was also the first time that U.S. Coast Guard naval engineers/management delineated FSOs in detail. Finally it was the first major application of this methodology. The results are considered highly satisfactory; Coast Guard management realized their assessment of FSOs was too lenient but that the exercise has merit. The analysis pointed out several deficiencies in the fire safety design such as

identification of redundant fire protection systems and where additional barriers should be installed. The project also served to identify areas where the SFSEM needed further development. Version 1.0 of SAFE was used for the PIR.

2.5.2. CGC VIGOROUS (WMEC 627)

A fire safety analysis of the Coast Guard Cutter VIGOROUS was conducted as a term project in a graduate level course in fire protection engineering at the Worcester Polytechnic Institute in 1990. [20] The methodology inherent in the SFSEM was utilized to analyze compartments below the main deck. The focus of this evaluation was on machinery, storage, and living/berthing areas. The analysis served two important purposes, first it pointed out the need for a computer program to automate the calculations so that a thorough analysis could be conducted in a reasonable time. Secondly the methodology was shown to be appropriate to identify deficiencies in the fire safety design of the vessel. In the case of the VIGOROUS it was clearly evident that the major deficiency was lack of an automatic fire detection system. The analysis also identified weaknesses in the fire protection systems for five specific compartments below the main deck. The SFSEM facilitated an evaluation of alternative fire safety designs to alleviate these problems. The project team also conducted a limited analysis of an actual fire on VIGOROUS that occurred in 1989; results of this analysis are documented in the Theoretical Basis of the SFSEM. [2]. While this effort yielded some interesting results, in general, the SFSEM should not be used to conduct a forensic-type post-mortem analysis of a real fire.

2.5.3. SMALL CUTTER FIRE PROTECTION PROJECT (SCFP)

The SCFP Project was a comprehensive effort to analyze the fire safety of small U.S. Coast Guard Cutters between 65' and 180' in length. The final reports in the project document and summarize the major results, conclusions and recommendations provided in the four interim reports submitted during the course of the project. [3, 10, 11, 12, 21, 22] In addition, the final reports include a detailed fire protection doctrine tailored for ten classes of Patrol Boats, Tugboats, and Buoy Tenders. Each cutter class doctrine provides information pertinent to fire science in part A, firefighting policy and guidance provided by the Commandant, U.S. Coast Guard for small cutters in part B, and procedures for combating all classes of fires in all conceivable compartments in part C.

The SAFE programs, versions 2.0, 2.1 and 2.1A, were utilized as the analytical tool to conduct a comprehensive analysis of the baseline fire safety and hypothetical improvements to achieve pre-established FSOs in the SCFP. [3, 12] Results indicate that the majority of compartments in small cutters meet FSOs with their existing passive and active fire protection features in effect. The methodology was shown to be a valuable tool to evaluate heretofore incomparable entities such as a better barrier or a more effective firefighting system and quantify their effectiveness. This study clearly demonstrates that it is feasible to reduce reliance on manual firefighting in small cutters by enhancing selective passive and active fire protection features. This study also identified several areas where the SFSEM could be enhanced to improve its effectiveness. Recommendations are also made to improve the fire safety of the cutters studied. [3, 10, 11, 12]

2.5.4. CGC VINDICATOR

The 225' CGC VINDICATOR is the first ex-USNS Ocean Surveillance Ship to be converted for use as a U.S. Coast Guard Medium Endurance Cutter. The Coast Guard planned to operate this ship under the minimally manned crew concept. In addition, since the ship only had one repair locker, a proposed location for a second repair locker was desired. The Coast Guard also wanted a fire protection doctrine developed for this class of cutter. This objective required the development of Part B of the fire protection doctrine for "large" cutters. Results of the fire safety analysis revealed that the ship exceeded fire safety objectives with all passive and active fire protection features in effect. However the passive fire protection on this cutter must be augmented by either automated or manual fire protection in order for all compartments to meet FSOs. This particular cutter had some unusual fire hazards, for example celotex dropped ceilings and marine plywood paneling are installed throughout the Main Deck, O1 Deck and O2 Deck. In addition one-piece fiberglass toilet/shower units are installed in every sanitary space. The analysis using the SFSEM clearly demonstrated that these hazards did not result in unacceptable fire protection levels in the ship. The complete technical report on this project is available through the National Technical Information Service. [9]

2.5.5. MAIN VERTICAL ZONE LENGTH EVALUATION

The SFSEM was used to study the impact on fire safety of a proposal to exceed the maximum length of a main vertical fire zone on a riverboat. [23] This project was accomplished by a six member team as a term project in a graduate level course at Worcester Polytechnic Institute in 1993. The maximum length of vertical fire zones was established by the Safety of Life at Sea (SOLAS) convention. The U.S. Coast Guard is responsible for regulating domestic ship construction and is frequently faced with the need to make a decision concerning equivalencies to requirements specified in the Code of Federal Regulations and applicable SOLAS regulations. The analysis revealed that lengthening the main vertical fire zone in this case actually decreases the fire growth hazard potential. This project was significant in that it demonstrated the feasibility of using a performance based methodology such as the SFSEM to assist in judgments of proposed equivalencies to prescriptive fire regulations.

3. FIRE SAFETY ANALYSIS OF THE WLB (R)

The most important objective in this project is to evaluate the fire safety of the WLB (R). The basic technical approach includes an analysis of the cutter's fire protection compared to its fire safety objectives using the Ship Fire Safety Engineering Method (SFSEM) as the computer-based analytical tool. This section of the report will discuss the results of the fire safety audit as well as the preliminary and detailed fire safety analyses of the WLB (R) using the SFSEM.

Normally a ship visit is performed to collect pertinent data needed to run the probabilistic model in SAFE. At the outset of the project however, it was not feasible to conduct a ship visit so a preliminary baseline analysis was performed which relied on default values, information obtained from the COR, and ship's drawings for much of the input data. This analysis will be referred to in this report as the preliminary baseline. Subsequently a ship visit was performed on the lead cutter, JUNIPER, in the WLB (R) class of seagoing buoy tenders. Data collected during this ship visit was curtailed due to scheduling conflicts, however sufficient data was collected to justify performing another baseline analysis. Actual data collected on board the cutter is clearly more accurate and representative than the data used in the preliminary baseline. Therefore results from the analysis of the baseline data set (ship visit data) is referred to in this report as the baseline results from the detailed fire safety analysis.

The following sections of this report will address the specific fire safety analysis results organized as follows:

- Fire Safety Audit. A fire safety audit is performed in conjunction with the JUNIPER ship visit. In addition, all relevant documentation pertaining to the fire safety of the cutter is thoroughly reviewed.
- Preliminary Baseline Analysis. The SFSEM and its implementing computer programs, SAFE, are used to perform a fire safety analysis based on a preliminary baseline data set populated with default values and data collected from drawings.
- Detailed Fire Safety Analysis. The SFSEM and its implementing computer programs, SAFE, are used to perform a detailed fire safety analysis based on the baseline data set populated from data collected during the JUNIPER ship visit.

3.1. FIRE SAFETY AUDIT

A fire safety audit consists of a review of documentation and observations of fire hazards and other conditions pertinent to fire safety noted during the ship visit. A review of the following documentation relevant to the fire safety design of the JUNIPER was conducted:

- Various Seagoing Buoy Tender (WLB) Drawings, prepared by Marinette Marine Corporation, Marinette, WI
- WLB (R) Circular of Requirements for the Seagoing Buoy Tender, published by the U. S. Coast Guard, dated 8/12/94 [1]
- USCGC JUNIPER Instruction 9555.1, Subject: Machinery Space Fire Fighting Doctrine for Class Bravo Fires, undated [24]

- Compartment Check-off Lists for the Seagoing Buoy Tender prepared by Marinette Marine Corporation, 11/29/95 [25]

The results of the fire safety audit are presented in the following sections organized according to the life cycle stages of a fire incident that starts with prevention and evolves through detection, containment, and extinguishment.

3.1.1. PREVENTION

The following observations were noted that directly affect this cutter's ability to prevent a fire:

- The ship is new and the crew displays the pride typically seen on a new cutter. This may account for the fact the ship is neat and clean with most items appropriately stowed. In particular there was no evidence of improperly stowed flammable liquids or compressed flammable gases.
- Engineering spaces are especially clean with no buildup of grease and oil in the bilges or on the external surfaces of the machinery. Good housekeeping practices such as those observed on the JUNIPER are a major factor in preventing unwanted ignitions.
- AFFF portable extinguishers are installed in some compartments. The Engineering Officer noted that these extinguishers are on board due to his insistence. This type of extinguisher is considered highly appropriate for the class B fire threats on this class cutter, however other cutters in the class may not be equipped with such AFFF portable extinguishers.

The compartmentation was reviewed to determine if adequate means of egress exist for crew members to escape from a fire and to assess the ability of the crew to access each compartment for the purpose of firefighting. The proposed compartmentation appears to be quite adequate to permit egress from all normally occupied spaces. It also appears that there is adequate access for firefighting to all compartments where a potential fire could occur.

The fire prevention phase also includes first aid or the initial attempts to extinguish a fire after ignition occurs but before the fire grows substantially beyond the point described as EB. First aid primarily involves an analysis of the type, quantity, and location of portable extinguishers. CO₂, PKP and AFFF portable extinguishers are installed throughout the cutter. Locations of extinguishers are noted in Part C of the fire protection doctrine in Appendix E of this report as well as in JUNIPER Instruction 9555.1 [24]. It appears that there are sufficient quantities of the appropriate types of portable extinguishers installed in suitable locations for the expected fire threat.

3.1.2. DETECTION

The minimal crew concept is extremely apparent on this cutter. The ship is much larger than a 210' (68 crew members) and approaches that of a 270' (100 crew members) yet there are only 40 crew members on the WLB (R). It is clear from informal discussions with various crew members that the crew is relying on the installed fire detection and automated fire suppression systems for fire safety. This emphasizes the need for the installed equipment to be as reliable as possible. There are two serious concerns that adversely affect the reliability of installed equipment on this ship. First, the ship has been delivered without a plan in effect for shore

support for preventive maintenance. The crew size may degrade their ability to properly maintain all of the sophisticated equipment and systems on this cutter. Therefore the reliability of the equipment that they are depending on may deteriorate. Secondly, unacceptably high vibration levels have been noted underway especially aft of the Mess Deck. The stern thruster motor for example, has already been replaced due to a failure related to excessive vibration. Severe vibration may also adversely affect the reliability of the fire detection and suppression equipment installed in the affected area of the ship.

The fire detection system installed on the WLB (R) is a Pyrotronics 3 Fire Alarm System. The system includes smoke (ionization), thermal, photoelectric, or flame detectors located in nearly every compartment. In addition the cutter is divided into 11 designated fire detection zones. The fire detection and alarm system provides audible and visual signals in the alarm/annunciator panel located in the Pilot House when abnormal or dangerous conditions trigger the sensing devices. The following specific comments are noted concerning the fire detection system on the WLB (R):

- The smoke detector in the Steering Gear Room (1-102-0-E) installed in the overhead near the entrance door is poorly located. It is installed inside deep frames such that the smoke layer would have to be several inches thick before the detector could sense the smoke and activate the alarm. It is feasible to relocate the detector to a more advantageous location such as directly over the hazard (steering gear). In addition, installation of additional detectors in adjacent "pockets" would improve the likelihood of early detection.
- Each fire zone contains one or more compartments, but the applicable fire zone is not identified in a visible manner within the compartment. Therefore a crewmember cannot generally notify the Pilot House which zone the fire is located in (although the compartment identification is readily apparent).
- Manual pull fire stations are located in strategic locations throughout the cutter, in addition there are multiple internal communication systems available to contact the Pilot House. It appears that the Pilot House could be notified very quickly in the event fire or smoke is detected.

3.1.3. CONTAINMENT

The minimal manning of this cutter and the large numbers of doors, hatches, windows, etc. precludes the crew's ability to rapidly "set ZEBRA" (close all the doors and hatches) throughout the ship. The crew on JUNIPER has apparently adopted the philosophy that ZEBRA will be set initially only in the area surrounding the fire, and as time and manpower permits, other doors and fittings will be closed. It takes approximately three minutes for the JUNIPER crew to set ZEBRA in the vicinity of the fire as opposed to approximately the same time for a crew on other cutters to set ZEBRA throughout the entire ship. While this approach seems adequate for small fires contained to the room of origin, a larger fire may overwhelm a small crew's ability to close the doors in advance of the spreading fire. Moreover setting ZEBRA only in the vicinity of the reported fire could permit the fire to spread rapidly if the location were reported inaccurately.

The ship visit and a review of the available documentation revealed the existence of the following problems which may contribute to an inability to contain the fire to a room of origin or enhance its ability to spread:

- There are several large hatches (3' x 5' and 3' x 6') installed on the main and second deck which are not fitted with a spring-loading device to enable one person to safely and quickly open or close the hatch. These hatches must be closed in a fire emergency and opened to permit access for firefighting. It is estimated that each hatch weighs in excess of 300 pounds, thus it takes two or three crew members to open or close a hatch. Apparently there are plans to retrofit these hatches with spring-loaded devices.
- Damage control fittings (e.g. watertight doors and hatches) are labeled with a damage control classification (e.g. X, Y, Z, W, etc) as required by the Naval Ships Technical Manual (NSTM), Chapter 079. It appears however, that many of the fittings are classified inconsistently and in some cases incorrectly. All fittings were assigned a classification in the preliminary baseline analysis based on the authors' interpretation of NSTM 079, notable differences were observed later during the ship visit. When the baseline analysis was performed the classification of the doors and hatches was changed to those found during the ship visit.
- Compartment check-off lists (CCOL) serve a useful purpose to quickly point out the existence and location of vital damage control items such as isolation valves and portable fire extinguishers used to contain a fire. The Engineering Officer reported that these lists are not always 100% accurate. There was insufficient time during the ship visit to verify the accuracy of all CCOLs. It is extremely important that these lists portray accurate and complete information concerning the location of all damage control fittings and firefighting equipment such as smoke detectors and portable fire extinguishers.
- Smoke curtains are installed in strategic locations such as passageways and at the base of ladders in companionways.

3.1.4. EXTINGUISHMENT

The following firefighting systems and equipment are installed on the JUNIPER.

- The firemain system is supplied by two electric fire pumps. Each fire pump is designed to provide the capacity, pressure, volume, and flow to support the simultaneous operation of the aft AFFF station Main Machinery Room sprinkler system, two firefighting stations, and either the Main Machinery Room or the Auxiliary Machinery Room 205 gpm dewatering eductor.
- The #1 fire pump is installed in the Main Machinery Room and #2 fire pump is installed in the Auxiliary Machinery Room. Seven remote controllers permit each fire pump to be operated from the following spaces: Pilot House, Main Machinery Control Console, Forward and Aft AFFF Stations, Damage Control Power Panel, Main Machinery Room, and Auxiliary Machinery Room.
- Two P-250 portable fire pumps are available for firefighting and dewatering. Two P-1 portable pumps and two electric submersible pumps are available for dewatering.
- Individual fixed CO₂ total flooding systems are installed in the Main Machinery Room, Auxiliary Machinery Room, Emergency Generator Room and Flammable Liquids Storeroom.
- Two fixed AFFF systems are installed to serve machinery spaces. Each system consists of a fixed AFFF proportioning station, bilge sprinkling nozzles, overhead sprinkling nozzles, and

AFFF hose stations. The following compartments are served by one of these systems: Bow Thruster Machinery Room, Main Machinery Room, Auxiliary Machinery Room, Stern Thruster Machinery Room, Steering Gear Room, SOR Machinery Room, and the Incinerator Room

- Dry type water sprinkler systems are installed to serve the Magazines and the Cargo Hold. Both systems consist of open orifice spray heads fitted to a hard pipe water distribution system. Both 360 degree dispersion deflectors and side wall type nozzles are installed to provide total coverage.
- Portable CO₂, PKP and AFFF extinguishers are installed throughout the cutter.

The above list clearly shows that this cutter is equipped with adequate quantities and appropriate types of automated and manual fire extinguishment equipment for responding to any fire emergency in any space. Informal discussions with crew members revealed heavy reliance on the sophisticated fire detection and automated fire suppression systems installed on this cutter to supplant the protection offered by a larger crew. As noted above, this emphasizes the need for conscientious preventive maintenance of this equipment to ensure the highest possible state of readiness and reliability. The lack of manpower on this cutter adversely affects their ability to perform preventive maintenance and the high vibration levels noted on this cutter adversely affects the reliability of the equipment.

3.2. PRELIMINARY FIRE SAFETY ANALYSIS

The preliminary baseline analysis was based on a review of the drawings and the COR. Since a ship visit was not feasible during this stage of the project, default values were used for some input data. The baseline data set was subsequently changed based on data collected during the ship visit and used to perform the baseline analysis. The following sections discuss the input data needed to run SAFE and presents the results of the preliminary baseline analysis.

There are two general types of input data required for SAFE to analyze the baseline and alternatives, factual and subjective. Factual data includes:

- type and location of bulkhead and deck materials
- compartment deck area and height
- type, location and quantity of automated and manual fire protection equipment
- type, location and quantity of smoke detectors
- size and orientation of ventilation duct openings (exhaust and supply)
- estimates of cellulose, plastics, and flammable liquid fuel loads

Subjective data is established based on engineering judgment and comparisons to similar parameters on other ships. This data includes:

- probabilities of flame termination
- firesafety objectives
- percent time each compartment is monitored

- applicable fire growth models

The following sections provide additional information concerning input data collected for the WLB (R) analysis categorized into factual and subjective input data.

3.2.1. FACTUAL INPUT DATA

Factual data is taken from drawings, other official documentation, or determined during the ship visit. Factual data also includes estimated data. For example it would be possible to exactly determine a compartment's fuel load by weighing each combustible. Since this is impractical, fuel loads are estimated based on engineering judgment and using rules of thumb determined from experience gained in numerous ship visits. The following sections describe the factual (and estimated) input data. Subjective input data which relies on engineering judgment is then discussed.

3.2.1.1. Ship's Geometry

The ship's drawings were converted into a three-dimension rendition using AUTOCAD, Release 13. Each compartment shown on the Booklet of General Plans was assigned a Compartment Use Indicator (CUI). Most of the default values established in SAFE are based on CUI. Since much of the input data for the WLB (R) relies on default values to a greater extent than other cutters previously analyzed, CUI assignments are particularly important. Type and location of bulkhead and deck materials are taken from ship's drawings, verified during the ship visit, and are documented in Appendix B, Table B.2. Compartment height and deck area are determined from the AUTOCAD drawings and shown in Appendix B, Table B.1.1.

3.2.1.2. Automated and Manual Fire Protection Systems

The location, type and quantity of installed and portable fire protection systems were obtained from the COR, ship's drawings, and the JUNIPER Main Machinery Space Fire Protection Doctrine. [24] This information is recorded in Appendix B, Table B.5. In general, this cutter is well protected with automated systems that include bilge and overhead AFFF sprinkling systems, water sprinkling systems, and CO₂ total flooding systems. As shown in Table B.5, some compartments are protected with two automated systems. The galley stove and deep fat fryer are protected by an aqueous potassium carbonate system. Portable AFFF, CO₂ and PKP fire extinguishers are located throughout the cutter. Finally firemain stations are installed throughout the cutter and include AFFF reentry hose stations.

3.2.1.3. Smoke Detectors

The Circular of Requirements (COR) for the WLB and the ship's drawings provide explicit detail concerning the type, location and quantity of fire and smoke detectors that are required to be installed. Ship's drawings, the JUNIPER Main Machinery Space Fire Protection Doctrine, and the CCOLs document where these devices are actually located on board the cutter. [24, 25] This information was verified during the ship visit. The type and quantity of all installed fire and smoke detectors are shown in Appendix B, Table B.4, including the calculated time to detection.

3.2.1.4. Ventilation

Prior to the actual ship visit, available drawings lacked the details necessary for accurate determinations of the area and height of each ventilation duct and opening. The Coastal Buoy Tender (WLM (R)) is a similar, albeit smaller buoy tender also built by Marinette Marine Shipyard. Therefore, the ventilation details for the preliminary baseline analysis of the WLB (R), recorded in Appendix D, Table D.1.2, were assumed to be similar to the data collected for the WLM (R). [12] Ventilation is a very important fire parameter in the pre-FRI and Post FRI fire growth regimes. Ventilation details were determined during the ship visit where the area and height of each ventilation opening was physically measured. The area and average height of all ventilation openings measured during the ship visit and used in the baseline analysis is recorded in Appendix B, Table B.1.2. The ship visit showed that ventilation data are significantly different on the WLB (R) compared to the WLM (R).

3.2.1.5. Fuel Loads

For the preliminary baseline analysis, estimates of cellulose, plastics and flammable liquid fuel loads, documented in Appendix D, Table D.7 were based on similar compartments in other cutters previously analyzed and also on conditions observed in the CGC HORNBEAM, a 180' Seagoing Buoy Tender. Fuel loads were estimated during the JUNIPER ship visit, recorded in Appendix B, Table B.7, and used to perform the baseline analysis. Marinette Marine Shipyard is in the process of retrofitting the JUNIPER with acoustic insulation installed on exposed portions of bulkheads in selected compartments apparently to reduce noise levels to acceptable levels specified in the COR. Since it is unknown which compartments will eventually receive this treatment, the contribution of the acoustic insulation was not taken into account as a fuel load in any compartment.

3.2.2. SUBJECTIVE INPUT DATA

Engineering judgment expresses an experienced and knowledgeable person's degree of belief. The SFSEM is a probabilistic-based fire risk analysis methodology. Engineering judgment is therefore appropriate to determine the likelihood that a fire will be terminated in a given compartment, assign firesafety objectives, and establish other important parameters needed to run SAFE as discussed in the following sections.

3.2.2.1. Probabilities of Flame Termination

For the preliminary baseline analysis probabilities of passive, automated and manual means of flame termination for each compartment were determined based on engineering judgment, and values assigned to similar compartments in previous cutters. SAFE default values were also used extensively, especially for the probabilities of flame termination in compartments entered as a result of a thermal or massive failure of a barrier. Probabilities of flame termination used in the preliminary baseline data set are documented in Appendix D, Table D.4.

During the ship visit it was discovered that the WLB (R) has plans for a five person in port duty section consisting of an OOD, a EOW, and three other watchstanders. In view of the extremely small in port duty section and other information collected during the ship visit the probabilities of flame termination especially for manual fire protection were revisited. The probabilities of flame termination were thus developed for both in port and at sea scenarios for the

baseline analysis as shown in Appendix B, Tables B.6.1 and B.6.2. In general, M values are reduced for in port scenarios compared to at sea scenarios.

3.2.2.2. Fire Safety Objectives

The frequency and magnitude of acceptable loss for each compartment are based on values for similar compartments established for cutters previously analyzed. Appendix B, Table B.3 lists the assigned FSOs for each compartment in the WLB (R).

3.2.2.3. Percent Monitored

The time to detect a fire is a function of the percent time a compartment is monitored. There are two possible ways a compartment can be monitored: by the ship's crew or by an installed fire detector. In those compartments monitored by an installed detector, 95% is assigned as the percent time the compartment is monitored both in port and at sea. This value reflects the reliability expected with the type of detectors proposed for installation in this cutter. In other compartments engineering judgment was utilized to assign a percent time the compartment is expected to be monitored (visited) by a crew member. The percentage of time each compartment is monitored in port and at sea is documented in Appendix B, Table B.4.

3.2.2.4. Fire Growth Models

There are 16 available fire growth models in SAFE that describe the nature and distribution of fuel packages. The model selected pre-determines two extremely important fire growth parameters: alpha and Qmax. Alpha is the fire growth coefficient in the heat release rate formula in the pre-FRI fire growth regime. Qmax describes the maximum heat release rate that is permitted regardless of the fuel load. These parameters in the fire growth models were based on empirical data collected in full scale tests. These tests were conducted in warehouses, basements, and other non-shipboard scenarios. Consequently many of the available fire growth models are a poor match to shipboard conditions. As in all previous cutter firesafety analyses, fire growth models for the WLB (R) were selected that most closely represent conditions observed and documented in Appendix B, Table B.8. There is some concern that the alpha and Qmax thus assigned to some compartments based on the selected fire growth model, may be higher than the observed fuel loads would justify. In general, high alpha and Qmax values would result in short FRI times and therefore higher relative loss factors would be expected. In other words, the results in some compartments may indicate a more dangerous condition than actual fuel load characteristics would warrant. Thus fire growth models are considered conservative.

3.2.3. HISTORICAL RECORDS OF FIRES ON OTHER CUTTERS

The Coast Guard MISREP database was researched for historical records of reported fires on all Coast Guard Cutters of comparable length and complexity to the WLB (R) during the period FY88 through FY92. In the Coast Guard fleet 34 medium endurance cutters (WMEC) are considered comparable in length and complexity to the WLB (R) as shown in Table 3.1. The number of cutter-years of data is reduced slightly due to the fact the last three 270' "BEAR" class cutters were delivered to the Coast Guard after October 1988. This table also shows the number of reported fires for each of these cutter classes. **There were 13 reported fires in 134 cutter-years of data, therefore based on statistics it may be concluded that a Medium Endurance**

Cutter will experience a reportable fire once every 10.3 years. Of these 13 fires, five were class A, four were class B and four were class C. Eleven of these fires were contained and extinguished within the room of origin and two spread to involve multiple compartments. Therefore fires that spread beyond the room of origin can be expected to occur on a WMEC once every 67 years, or the fleet of 34 existing WMEC's can expect a multiple room fire once every two years. This data is considered relevant to the WLB (R) class of seagoing buoy tenders.

Table 3.1 Historical Records of Reported Fires in WMEC's

Class of WMEC	Number of Cutters in Class	Number of Cutter-Years	Number of Reported Fires	Class A Fires	Class B Fires	Class C Fires
270'	13	50	3	1	2	0
213'	3	12	2	1	0	1
210'	16	64	6	2	2	2
205'	1	4	1	1	0	0
180'	1	4	1	0	0	1
Totals	34	134	13	5	4	4

3.2.4. PRELIMINARY BASELINE RESULTS (PRE-SHIP VISIT)

Tables 3.2 and 3.3 contain results of running the individual target output option in SAFE on the preliminary baseline data set for the WLB (R). The hierarchy for compartments listed in both tables is determined by the results from scenario 1 which includes the following conditions:

- Location: In Port
- Material Condition: XRAY
- SAFE Run Time: 60 minutes
- Fire Protection Features in Effect: Passive (I), Automated (A), and Manual (M)

The results are shown in terms of relative loss factors (RLF). These factors indicate the performance of a compartment normalized to its fire safety objectives. For example if a RLF = 1.0, the compartment meets it's FSOs. If a RLF is greater than 1.0 the compartment fails to meet it's FSOs and an improvement in fire protection is needed. If a RLF is less than 1.0 the compartment exceeds it's FSOs and may indicate that the compartment is over-protected and a reduction in fire protection may be justified. Compartments returning the highest RLF are listed first followed by compartments with RLFs of descending magnitude. It is obvious that these tables list only a small number of the 167 compartments in the WLB (R). Only compartments with a RLF that exceeds 0.01 in Scenario 1 are listed. Scenario 1 represents worse case (compared to scenarios 2 and 3) with all fire protection features in effect.

Table 3.2 displays results for standard scenarios 1 and 3 with all levels of fire protection (I, A, and M) in effect. Since there are no YOKE doors or hatches in the preliminary baseline data set, scenario 2 duplicates results from scenario 1, therefore results from scenario 2 are not shown. All compartments exceed their FSOs by a substantial margin both in port and at sea. Normally differences in manning levels in port and at sea result in longer times to detect a fire and therefore higher RLFs are expected in scenarios 1 and 2 compared to scenario 3. These differences are greatly reduced when there are a substantial number of automatic smoke detectors installed in the ship because their probability of detecting fires is not affected by reduced manning levels. There is a difference in results in the WLB (R) between in port and at sea (scenarios 1 and 3 in Table 3.2), however these differences are in the third and fourth decimal places and are lost when results are rounded to two decimal places. The A and M values used in the preliminary baseline data set (pre-ship visit) did not reflect the extraordinarily low manning levels in port. When this fact was discovered during the ship visit, A and M values were adjusted for the baseline data set used in the baseline analysis for in port scenarios (post ship visit).

Table 3.2
WLB-R RELATIVE LOSS FACTORS

Plan ID	Compartment Name	CUI	MAL	FAL	Run 3-11 Scenario 1 Xray, In Port	Run 3-15 Scenario 3 Yoke, At Sea
4-82-0-E	AUXILIARY MACHINERY ROOM	QA	2	22	0.26	0.26
1-66-0-L	CREW MESS	LL	2	24	0.25	0.25
4-66-0-E	MAIN MACHINERY ROOM	EM	2	26	0.21	0.21
03-76-0-Q	STACK	TU	2	21	0.19	0.19
01-78-3-E	EMERGENCY GENERATOR ROOM	QE	2	24	0.19	0.19
1-76-0-Q	MAIN MACHINERY ROOM UPTAKE	TU	2	26	0.18	0.18
1-85-2-Q	AFF STATION	QA	2	23	0.17	0.17
2-89-1-C	ENGINEERING CONTROL CENTER	C	2	24	0.16	0.16
2-57-4-E	WATER SUPPLY EQUIPMENT ROOM	QA	2	22	0.15	0.15
4-92-0-E	STERN THRUSTER MACHINERY ROOM	EM	2	24	0.14	0.14
1-66-1-Q	GALLEY ANNEX	QG	2	26	0.14	0.14
1-77-3-L	CREW LOUNGE	LL	3	16	0.11	0.11
1-18-2-Q	AFF STATION	QA	2	24	0.1	0.1
4-12-0-E	BOW THRUSTER MACHINERY ROOM	EM	2	24	0.1	0.1
1-74-2-Q	DAMAGE CONTROL REPAIR LOCKER NO. 2	QA	2	24	0.08	0.08
2-21-2-Q	POTABLE WATER PUMP ROOM	QA	2	24	0.08	0.08
1-18-1-Q	DAMAGE CONTROL REPAIR LOCKER NO. 1	QA	2	24	0.07	0.07
1-77-2-L	CPO MESS & LOUNGE	LL	3	16	0.07	0.07
1-21-2-Q	ATON SHOP	QS	2	23	0.06	0.06
2-57-1-Q	MACHINE SHOP	QS	2	20	0.06	0.06
2-48-2-E	SOR PUMP ROOM	QA	2	23	0.06	0.06
1-66-3-Q	SCULLERY	QG	2	26	0.05	0.05
03-66-01-C	ELECTRONICS IC & GYRO ROOM	C	2	24	0.04	0.04
03-56-0A-C	PILOT HOUSE	C	2	26	0.04	0.04
03-56-0B-C	PILOT HOUSE	C	2	26	0.03	0.03
02-66-0-C	RADIO ROOM	C	2	26	0.01	0.01
1-6-2-A	FLAMMABLE LIQUID STOREROOM	K	1	30	0.01	0.01

Compartments listed have
MAL of 1-3 and RLF>.01

All Scenarios include I, A, and M

Table 3.3
WLB-R RELATIVE LOSS FACTORS

Plan ID	Compartment Name	CUI	MAL	FAL	Run 3-11		Run 3-12		Run 3-13		Run 3-14	
					Scenario 1 I, A & M	I & A	Scenario 4 I & A	Scenario 7 I & M	Scenario 10 I Only			
4-82-0-E	AUXILIARY MACHINERY ROOM	QA	2	22	0.26	0.36	0.56	0.79				
1-66-0-L	CREW MESS	LL	2	24	0.25	0.57	0.71	1.53				
4-66-0-E	MAIN MACHINERY ROOM	EM	2	26	0.21	0.29	0.49	0.64				
03-76-0-Q	STACK	TU	2	21	0.19	0.33	0.41	0.73				
01-78-3-E	EMERGENCY GENERATOR ROOM	QE	2	24	0.19	0.32	0.54	0.98				
1-76-0-Q	MAIN MACHINERY ROOM URTAKE	TU	2	26	0.18	0.27	0.39	0.55				
1-85-2-Q	AFFF STATION	QA	2	23	0.17	0.27	0.35	0.55				
2-89-1-C	ENGINEERING CONTROL CENTER	C	2	24	0.16	0.27	0.34	0.54				
2-57-4-E	WATER SUPPLY EQUIPMENT ROOM	QA	2	22	0.15	0.22	0.31	0.42				
4-92-0-E	STERN THRUSTER MACHINERY ROOM	EM	2	24	0.14	0.19	0.33	0.45				
1-66-1-Q	GALLEY ANNEX	QG	2	26	0.14	0.38	0.43	1.04				
1-77-3-L	CREW LOUNGE	LL	3	16	0.11	0.23	0.29	0.61				
1-18-2-Q	AFFF STATION	QA	2	24	0.1	0.13	0.15	0.2				
4-12-0-E	BOW THRUSTER MACHINERY ROOM	EM	2	24	0.1	0.12	0.2	0.24				
1-74-2-Q	DAMAGE CONTROL REPAIR LOCKER NO. 2	QA	2	24	0.08	0.12	0.23	0.34				
2-21-2-Q	POTABLE WATER PUMP ROOM	QA	2	24	0.08	0.1	0.12	0.16				
1-18-1-Q	DAMAGE CONTROL REPAIR LOCKER NO. 1	QA	2	24	0.07	0.14	0.13	0.23				
1-77-2-L	CPO MESS & LOUNGE	LL	3	16	0.07	0.14	0.19	0.38				
1-21-2-Q	ATON SHOP	QS	2	23	0.06	0.13	0.1	0.25				
2-57-1-Q	MACHINE SHOP	QS	2	20	0.06	0.08	0.13	0.19				
2-48-2-E	SOR PUMP ROOM	QA	2	23	0.06	0.11	0.13	0.21				
1-66-3-Q	SCULLERY	QG	2	26	0.05	0.08	0.14	0.22				
03-66-01-C	ELECTRONICS IC & GYRO ROOM	C	2	24	0.04	0.08	0.04	0.08				
03-56-0A-C	PILOT HOUSE	C	2	26	0.04	0.06	0.04	0.06				
03-56-0B-C	PILOT HOUSE	C	2	26	0.03	0.05	0.03	0.05				
02-66-0-C	RADIO ROOM	C	2	26	0.01	0.03	0.01	0.04				
1-6-2-A	FLAMMABLE LIQUID STOREROOM	K	1	30	0.01	0.02	0.01	0.02				

Compartments listed have
MAL of 1-3 and RLF>.01

All Scenarios are Xray, In Port

Table 3.3 displays results in material condition XRAY, in port, with various combinations of fire protection features in effect (Scenarios 1, 4, 7, and 10) These results show that two compartments fail to meet FSOs and a third nearly fails with only passive fire protection in effect. Therefore passive fire protection has to be augmented by either automated or manual fire protection in order for the cutter to meet FSOs in all compartments. On the other hand, as shown in scenario 4, Table 3.3, all compartments exceed FSOs with passive and automated fire protection in effect. The preliminary baseline analysis thus indicates that the WLB (R) exceeds FSOs in all compartments without reliance on manual fire protection efforts by the crew.

It is important to note that these results are based on the preliminary baseline data set. The next section discusses the detailed fire safety analysis that was performed subsequent to the ship visit on the JUNIPER which permitted populating the baseline data set with actual data collected on board the cutter.

3.3. DETAILED FIRE SAFETY ANALYSIS USING SFSEM/SAFE (POST-SHIP VISIT)

The SFSEM was used to conduct a nine step fire safety analysis on the JUNIPER. The following sections discuss each of these steps in sequence.

3.3.1. LOAD DATABASE WITH SHIP'S GEOMETRY

The compartmentation shown on the general arrangement drawings was modeled in AutoCAD and the pre-printed ship visit forms were produced. The drawings thus produced in AutoCAD for each deck level are shown in Appendix A. Large compartments such as the Pilot House, Dry Provision Storeroom, one Void, four Salt Water Ballast Tanks and the long passageways on the Main Deck, 01 Deck, and 02 Deck were divided into multiple compartments connected by zero strength barriers for modeling purposes. Due to the extensive number of compartments, it was not possible to print the names of the compartments in the plan views of each deck. Therefore a table is added to each deck level drawing that provides the compartment names and identification numbers shown on the drawing. Information concerning the deck area and compartment height is tabulated in Appendix B, Table B.1.1.

3.3.2. CONDUCT SHIP VISIT

The data collected during the ship visit (Appendix B) compared to the data used in the preliminary baseline data set (Appendix D) clearly show significant differences concerning fuel loads, ventilation details, and determination of probabilities of flame termination. Other minor changes in fire safety objectives and damage control classifications of certain doors and hatches are not specifically listed in Appendix D. The quality of a fire safety analysis is directly proportional to the accuracy of the input data used in SAFE. In general it appears that default values, used when actual data is not available, lead to results that indicate the ship is safer than actual conditions would warrant as discussed in section 3.3.6 below.

3.3.3. LOAD SAFE INPUT VALUES

SAFE input values that were based on default values and a review of the COR and ship's drawings and used in the preliminary baseline analysis are documented in Appendices B and D.

Appendix B contains SAFE input values that were used in the baseline analysis. This data was based on the best information collected from all sources including the ship visit.

3.3.4. CALCULATE FRI TIMES AND POST-FRI HEAT RELEASE RATES

A fire growth model was selected for each compartment that most closely approximated the fuel loads noted during the ship visit based on engineering judgment and the definitions contained in Appendix C of the Theoretical Basis of the SFSEM [2]. The pre-FRI fire growth rate (α) used in the pre-FRI heat release rate calculation and the maximum heat release rate (Q_{max}) are pre-determined by the fire growth model selected. The Post-FRI heat release rates (Q) and FRI times are calculated in SAFE. All of these fire parameters are tabulated for each compartment in Appendix B, Table B.8. The algorithms for the calculations are also described in the Theoretical Basis of the SFSEM [2].

FRI time is a critically important fire parameter because it determines the length of time between EB and the development of sufficiently high compartment temperatures that full room involvement conditions is assured. When FRI is achieved, conditions in the compartment are assumed to be incapable of supporting life and the heat energy of the burning fuel is assumed to begin impacting the barriers. Therefore, if FRI is infinite (or greater than 60 minutes for practical purposes) the fire will be limited to the compartment. On the other hand if FRI is very short (for example, two or three minutes) there may be little chance that the fire party can respond quickly enough to extinguish the fire in the compartment unless there is little fuel load. In this event, the available fuel may be consumed quickly and the fire may be easily extinguished by the fire party. The ability to achieve FRI is dependent on ventilation. An assumption is made in SAFE that every compartment has enough ventilation to achieve FRI. In an actual ship many compartments may be rendered relatively air-tight, thus this is a conservative assumption. A review of the calculated FRI times tabulated in Appendix B, Table B.8 show expected results for all compartments.

3.3.5. RUN PROBABILISTIC MODEL

The individual target option was specified as an output option for running the probabilistic model in the fire safety analyses of previous cutters as well as the WLB (R). This option permits a rapid comparison of each compartment as a target compartment compared to pre-established fire safety objectives for fires that may originate in any compartment. In other words it provides a means to identify "victims" of fires which may start in any compartment (including the target) and ultimately involve the target compartment. Results of the baseline fire safety analysis with the individual target option run on the baseline data set is documented in Appendix C, Individual Target Option - Summary Level Report and discussed in section 3.3.6.1 of this report. These results do not however, provide a great deal of insight into the primary source compartments for fires that ultimately result in the loss of target compartments. Furthermore, a careful review of results achieved in previous analyses revealed that the target compartments with the highest RLFs (most frequently lost compared to FSOs) were not the engineering spaces which have the highest frequency of EB. This result seemed counter-intuitive and prompted a thorough review of the algorithm associated with this output option in SAFE.

The review of the individual target option revealed that the algorithm requires independent fire paths to accurately accumulate results for the calculation of RLFs. The methodology, however, models the real world which, in general, does not produce independent fire paths. Thus, the algorithm calculates imprecise, albeit conservative, RLFs. Results are more accurate for engineering spaces and less accurate for other spaces causing them to have higher-than-actual RLFs (less fire safe). Since these results do not lend any insight into the primary sources of fires, the probabilistic model was also run specifying the barrier output option to obtain information relative to sources of fires. Results of the baseline fire safety analysis with the barrier option run on the baseline data set is documented in Appendix C, Barrier Option - Summary Level Report. These results indicate that engineering spaces dominate as the most likely sources of all fires on the WLB (R) and are discussed in more detail in section 3.3.6.2 of this report. This result is expected in view of the fact that the frequency of EB is much greater in engineering spaces than in other spaces in the ship.

A review of the individual target option results provides insight into the performance of target compartments and a review of the barrier option provides insight into the sources of fires. By identifying probable fire paths (for one or two compartments beyond the room of origin) from likely rooms of origin, the crew can enhance their ability to develop realistic fire drill scenarios for training purposes. Accordingly, the results of the barrier option was used to help select probable rooms of origin and the path option in SAFE was run with these compartments selected as the rooms of origin. Results of the baseline fire safety analysis with the path option run on the baseline data set is documented in Appendix C, Path Option - Summary Level Report, and Path Option - Detail Level Report and discussed in section 3.3.6.3 of this report.

3.3.6. ANALYZE BASELINE RESULTS

The complete baseline results for the WLB (R) are documented in Appendix C in the form of summary level and/or detail level reports specifying the following output options in SAFE:

- Individual Target Option - Summary Level Report (all 12 standard and non standard scenarios)
- Barrier Option - Summary Level Report (XRAY, In Port, I, A, & M scenario)
- Path Option - Summary Level Report (YOKE, At Sea, I, A, & M scenario for the following rooms of origin: Auxiliary Machinery Room, Main Machinery Room, Bow Thruster Machinery Room, Crews Stateroom 1-85-3-L, and Cargo Hold)
- Path Option - Detail Level Report (YOKE, At Sea, I, A, & M scenario for the following rooms of origin: Auxiliary Machinery Room, Main Machinery Room, Bow Thruster Machinery Room, Crews Stateroom 1-85-3-L, and Cargo Hold)

The following summarizes some of the basic assumptions made in SAFE and by the analyst that affect the results of the fire safety analysis:

- FRI times are based on a rise of ambient temperatures in the compartment of 500 degrees celsius.
- Rate of heat release in the pre-FRI fire growth regime is based on an "alpha-T- squared" fire growth curve.

- Rate of heat release in the post-FRI fire growth regime is based on $1500 \cdot AH^{0.5}$, (stoichiometric combustion conditions).
- The Ingberg conversion is used for the determination of heat energy impact on the barriers. Moreover this heat energy is assumed to impact the barriers only after FRI is achieved.
- Fire paths are assumed to be independent in the individual target option. Since actual fire paths are dependent the results predict target compartments are not as safe as they are in reality.
- In a fire, ventilation fans are secured. Significantly less air can flow through the ductwork than the natural vent opening assumed in the calculations.
- Based on the reliability of the detectors, it is assumed that fire will be detected with 95% certainty in compartments protected by a single detector. If multiple detectors are in the space, it is assumed that fire will be detected with 99% certainty.
- An unimpaired, fully trained crew is assumed to be on board underway. Moreover it is assumed that a full complement of crew is on board.
- The large hatch covers on this cutter are modeled as vent openings since, without spring-loaded devices, it is unlikely they can be closed quickly when setting ZEBRA.

The net effect of these assumptions on the results is considered conservative. In other words it is believed that the fire safety of this ship is better (safer) than results indicate.

3.3.6.1. Individual Target Option

An excerpt from the individual target option results are shown in Tables 3.4 and 3.5 and list only compartments with RLFs greater than or equal to 0.10 and a MAL of 1 - 3 for selected scenarios. These two tables summarize the most interesting results of the baseline analysis. The RLFs shown in Table 3.4 for the two in port scenarios (XRAY and YOKE) are very similar. This indicates that there are relatively few doors, scuttles and hatches labeled YOKE. A review of the access classifications in Appendix B, Table B.2 reveals that there are only six doors, two large hatches, and eight small hatches labeled YOKE. Six of the eight small hatches lead to weather (which does not contribute to fire spread). Thus little difference between the two in port scenarios is to be expected.

A small portion of the differences in the two YOKE scenarios, in port and at sea (scenarios 2 and 3), shown in Table 3.4 may be attributed to the difference in the percent (time) monitored for each compartment in port and at sea as documented in Appendix B, Table B.4. In general, it is more likely that a crew member will discover a fire earlier at sea than in port due to the higher manning levels at sea. Therefore, lower RLFs (safer ship) are expected for at sea scenarios than in port scenarios. However, the percent time monitored is frequently driven by the presence of installed fire detectors. If a fire detector is present, the percent monitored is set to 95% for both inport and at sea conditions (less than 100% to account for the reliability of the instrument). Therefore, since a comprehensive fire detection system is installed in the WLB (R) that monitors most compartments, very little or no difference is expected in RLFs between the two YOKE scenarios (in port and at sea) attributable to percent time monitored. The differences between the two YOKE scenarios shown in Table 3.4 are undoubtedly due to the large

differences in the probability of manual extinguishment for a full crew at sea and a greatly reduced (5-person) crew in port.

Table 3.5 compares varying levels of fire protection for the in port, XRAY scenario. As expected, the RLFs increase with decreasing levels of fire protection. The results also show that the rank ordering of compartments from most dangerous (highest RLF) to safest (lowest RLF) is approximately the same among the four scenarios. **A thorough review of the baseline fire safety analysis results clearly show that with passive (I), automated (A), and manual (M) fire protection in effect, all compartments in the WLB (R) exceed FSOs by a substantial margin.** This means that no improvements are necessarily required to bring the WLB (R) up to minimally acceptable fire safety levels as defined in section 2.4.2.6. As shown in Table 3.5, all compartments meet FSOs with just I and A in effect, but with just I and M in effect, four compartments fail to meet FSOs and one additional compartment is close to failing as well. Ten compartments fail to meet FSOs and 1 compartment is marginally acceptable with just passive fire protection in effect. Therefore it is clear that automated fire extinguishment systems are required to augment passive fire protection in order for the WLB (R) to meet fire safety objectives. These results show that the crew on the WLB (R) must rely on the protection afforded by the automatic detection and fire extinguishment systems installed on this cutter. Therefore, the reliability of these equipments and systems is paramount.

Table 3.4
WLB-R RELATIVE LOSS FACTORS

Plan ID	Compartment Name	CUI	MAL	FAL	Run 24-152		Run 24-156		Run 23-148	
					Scenario 1 Xray, In Port	Scenario 2 Yoke, In Port	Scenario 2 Yoke, In Port	Scenario 3 Yoke, At Sea		
1-66-0-L	CREW MESS	LL	2	24	0.44	0.40	0.32			
01-68-0-Q	SHIPS OFFICE	QO	2	22	0.42	0.37	0.28			
03-76-0-Q	STACK	TU	2	21	0.37	0.31	0.25			
01-68-1-L	MEDICAL TREATMENT ROOM	LM	2	22	0.32	0.28	0.21			
1-66-1-Q	GALLEY ANNEX	QG	2	26	0.22	0.21	0.16			
02-66-0-C	RADIO ROOM	C	2	26	0.22	0.17	0.12			
01-78-3-E	EMERGENCY GENERATOR ROOM	QE	2	24	0.21	0.19	0.17			
1-76-0-Q	MAIN MACHINERY ROOM UPTAKE	TU	3	16	0.21	0.18	0.16			
4-66-0-E	MAIN MACHINERY ROOM	EM	2	26	0.20	0.17	0.16			
1-71-2-Q	ENG LOG OFFICE & DC CENTRAL	QO	2	22	0.19	0.18	0.15			
2-89-1-C	ENGINEERING CONTROL CENTER	C	2	24	0.17	0.14	0.13			
2-57-4-E	WATER SUPPLY EQUIPMENT ROOM	QA	2	22	0.16	0.13	0.12			
1-102-0-E	STEERING GEAR ROOM	EM	2	26	0.14	0.00	0.00			
4-92-0-E	STERN THRUSTER MACHINERY ROOM	EM	2	24	0.12	0.09	0.09			
4-82-0-E	AUXILIARY MACHINERY ROOM	QA	2	22	0.12	0.08	0.08			
03-56-0B-C	PILOT HOUSE (CHART AREA)	C	2	26	0.11	0.09	0.07			
02-73-0-Q	FAN ROOM	QF	2	22	0.11	0.09	0.07			
2-59-1-Q	ELEC/ELEX WORKSHOP & STOREROOM	QS	2	20	0.11	0.10	0.08			
2-57-1-Q	MACHINE SHOP	QS	2	20	0.10	0.09	0.08			

Compartments listed have
MAL of 1-3 and RLF>.1 in Scenario 1

All Scenarios include I, A, and M

Table 3.5
WLB-R RELATIVE LOSS FACTORS

Plan ID	Compartment Name	CUJ	MAL	FAL	Run 24-152 Scenario 1 I, A & M	Run 24-153 Scenario 4 I & A	Run 24-154 Scenario 7 I & M	Run 24-155 Scenario 10 I Only
1-66-0-L	CREW MESS	LL	2	24	0.44	0.87	1.70	3.30
01-68-0-Q	SHIPS OFFICE	QO	2	22	0.42	0.96	1.44	3.15
03-76-0-Q	STACK	TU	2	21	0.37	0.54	0.99	1.40
01-68-1-L	MEDICAL TREATMENT ROOM	LM	2	22	0.32	0.81	1.22	3.03
1-66-1-Q	GALLEY ANNEX	QG	2	26	0.22	0.45	0.88	1.74
02-66-0-C	RADIO ROOM	C	2	26	0.22	0.64	0.62	2.05
01-78-3-E	EMERGENCY GENERATOR ROOM	QE	2	24	0.21	0.30	1.13	2.02
1-76-0-Q	MAIN MACHINERY ROOM UPTAKE	TU	3	16	0.21	0.27	0.60	0.74
4-66-0-E	MAIN MACHINERY ROOM	EM	2	26	0.20	0.24	0.77	0.93
1-71-2-Q	ENG LOG OFFICE & DC CENTRAL	QO	2	22	0.19	0.35	0.80	1.34
2-89-1-C	ENGINEERING CONTROL CENTER	C	2	24	0.17	0.24	0.67	0.94
2-57-4-E	WATER SUPPLY EQUIPMENT ROOM	QA	2	22	0.16	0.21	0.50	0.68
1-102-0-E	STEERING GEAR ROOM	EM	2	26	0.14	0.15	0.24	0.26
4-92-0-E	STERN THRUSTER MACHINERY ROOM	EM	2	24	0.12	0.14	0.45	0.56
4-82-0-E	AUXILIARY MACHINERY ROOM	QA	2	22	0.12	0.14	0.55	0.68
03-56-0B-C	PILOT HOUSE (CHART AREA)	C	2	26	0.11	0.40	0.29	1.20
02-73-0-Q	FAN ROOM	QF	2	22	0.11	0.44	0.29	1.21
2-59-1-Q	ELEC/ELEX WORKSHOP & STOREROOM	QS	2	20	0.11	0.17	0.46	0.73
2-57-1-Q	MACHINE SHOP	QS	2	20	0.10	0.16	0.44	0.69

Compartments listed have
 MAL of 1-3 and RLF > .1 in Scenario 1

All Scenarios are Xray, In Port

3.3.6.2. Barrier Option

A review of the barrier option results in Appendix C show that, as expected, engineering spaces dominate as probable rooms of origin in the WLB (R). This is due to the higher frequencies of EB, the relatively short FRI times in these spaces, and the larger numbers of adjacent spaces which yields more fire paths.

A thorough review of the barrier option results provides insight into the most probable rooms of origin that may contribute to fires that eventually could involve multiple compartments. These results coupled with the path option results will then provide useful information on the adjacent rooms in potential fire paths and help the crew to formulate realistic fire drill scenarios. The next section discusses the path option results from the baseline analysis of the WLB (R).

3.3.6.3. Path Option

The path option in SAFE provides the following details for all fire paths from a user-specified room of origin in a user-specified scenario (e.g. YOKE, At Sea, I, A, & M in effect):

- The time established burning will occur in each room in the fire path
- The FRI time for each room in the fire path
- The time to compartment burnout for each room in the fire path
- The cumulative probability of limiting the fire in the room of origin and in each succeeding room in the fire path
- The cumulative probability of limiting the fire for each barrier that fails allowing the fire to enter the next room
- The mode of failure for each barrier (Tbar or Dbar)

The information provided in the path option provides the necessary information to construct a graphical representation of all possible cumulative L-curves from any specified room of origin. The barrier option and engineering judgment were used to select the Auxiliary Machinery Room (4-82-0-E), the Main Machinery Room (4-66-0-E), the Bow Thruster Machinery Room (4-12-0-E), the Cargo Hold (2-30-0-AA), and Crews Stateroom (1-85-3-L) as rooms of origin in the WLB(R). The path option was specified and summary level and detail level reports were generated for these compartments. The YOKE, At Sea, I, A, & M in effect scenario was selected because it is believed that in port fires will be fought with outside assistance due to the extremely small in port duty section. Results from the path option were used to construct L-curves, shown in Figures 3.1 through 3.4, that provide the following useful information:

- The L-curve for the fire path with the least cumulative probability of limiting the fire (the highest probability of fire spread).
- The L-curve for the fire path with the highest cumulative probability of limiting the fire (the least probability of fire spread).
- The expected time established burning will occur in each room in the fire path.
- The cumulative probability of limiting the fire for each room and barrier in the fire paths shown.

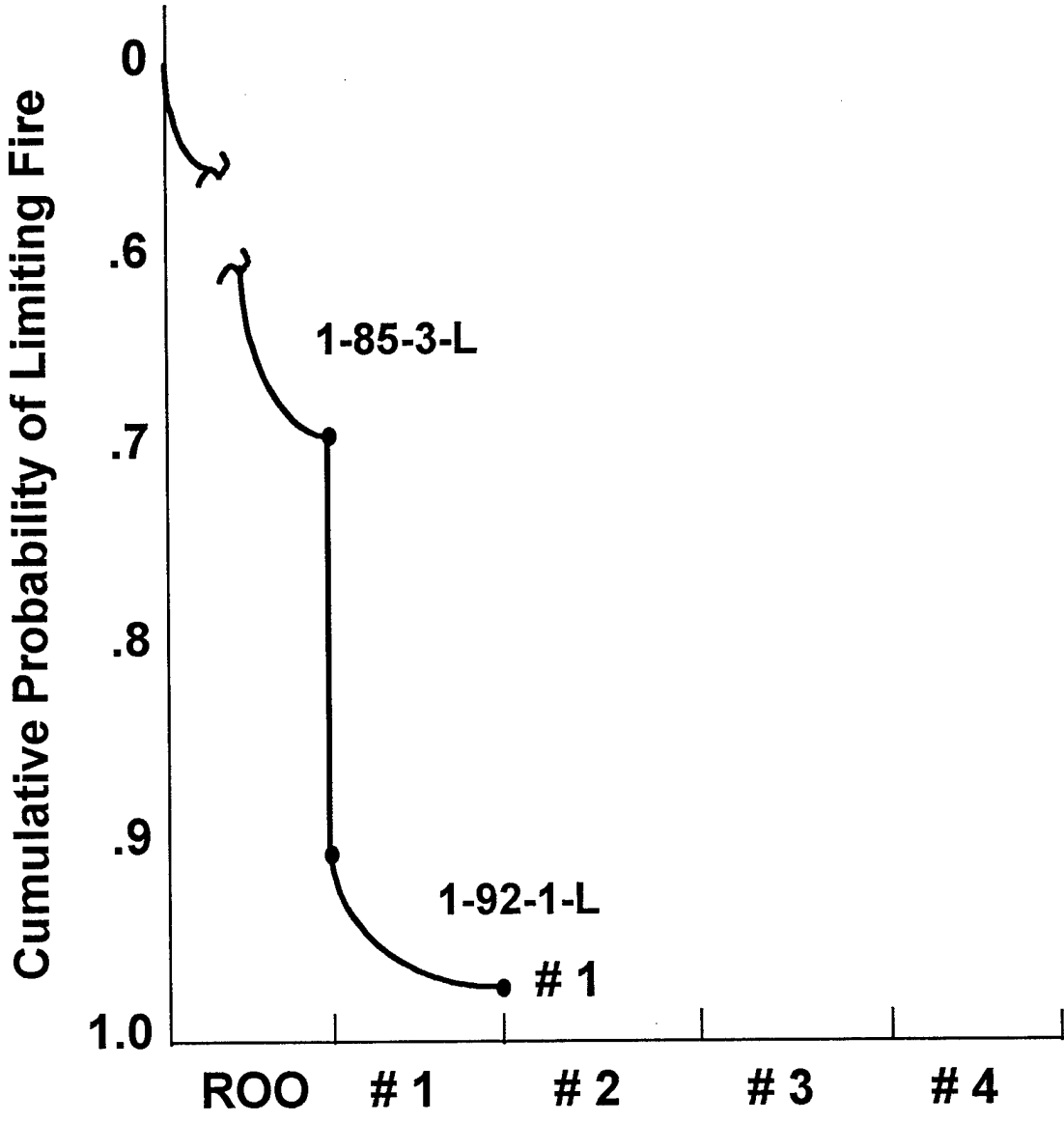

	Rooms in Fire Path	
Time to EB		
Path # 1	0	48
(minutes)		

Figure 3.1 Cumulative L-curve of Fire Paths from 1-85-3-L

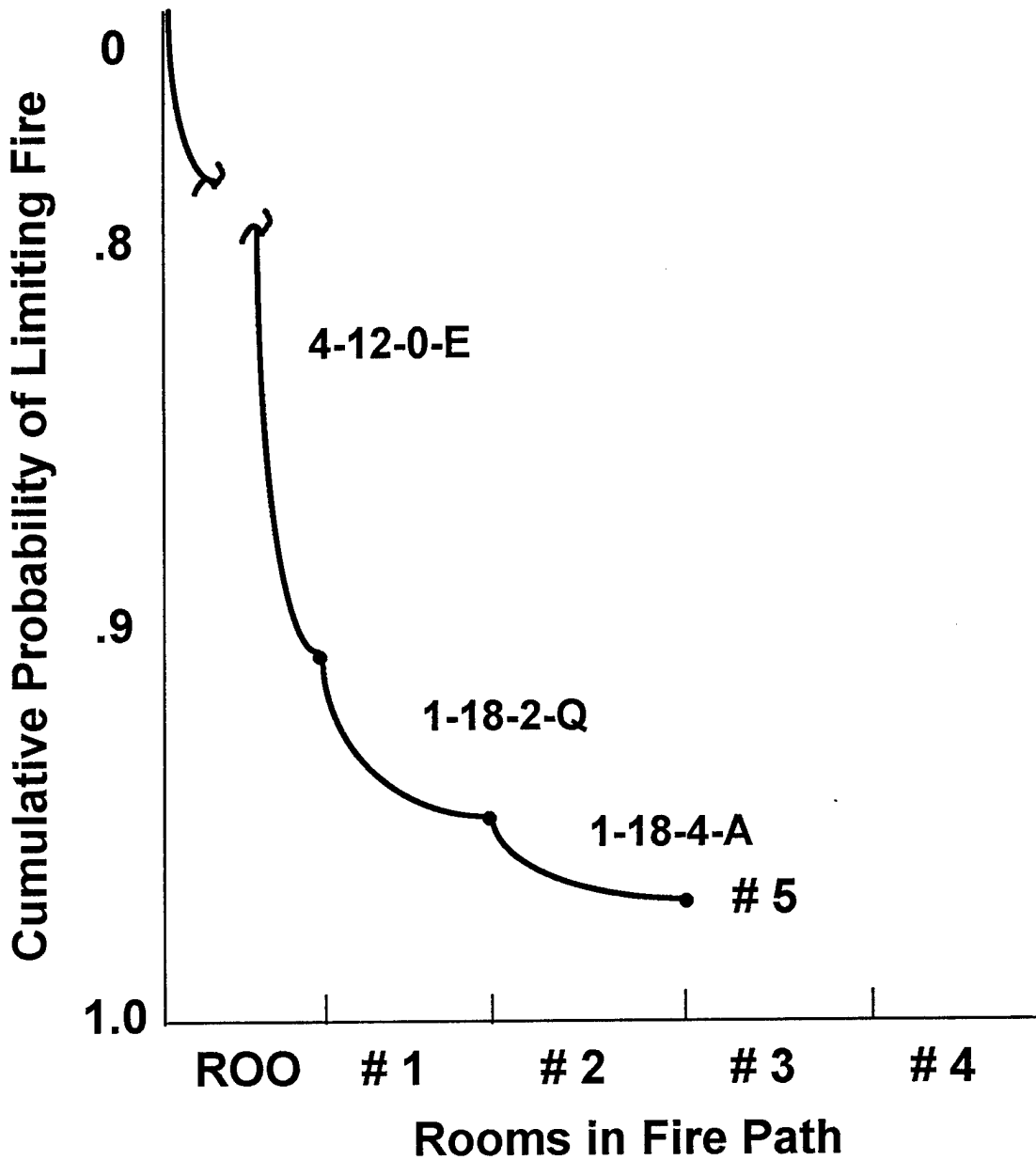

Time to EB Path # 5 (minutes)	ROO	# 1	# 2
	0	16	16

Figure 3.2 Cumulative L-curve of Fire Paths from 4-12-0-E

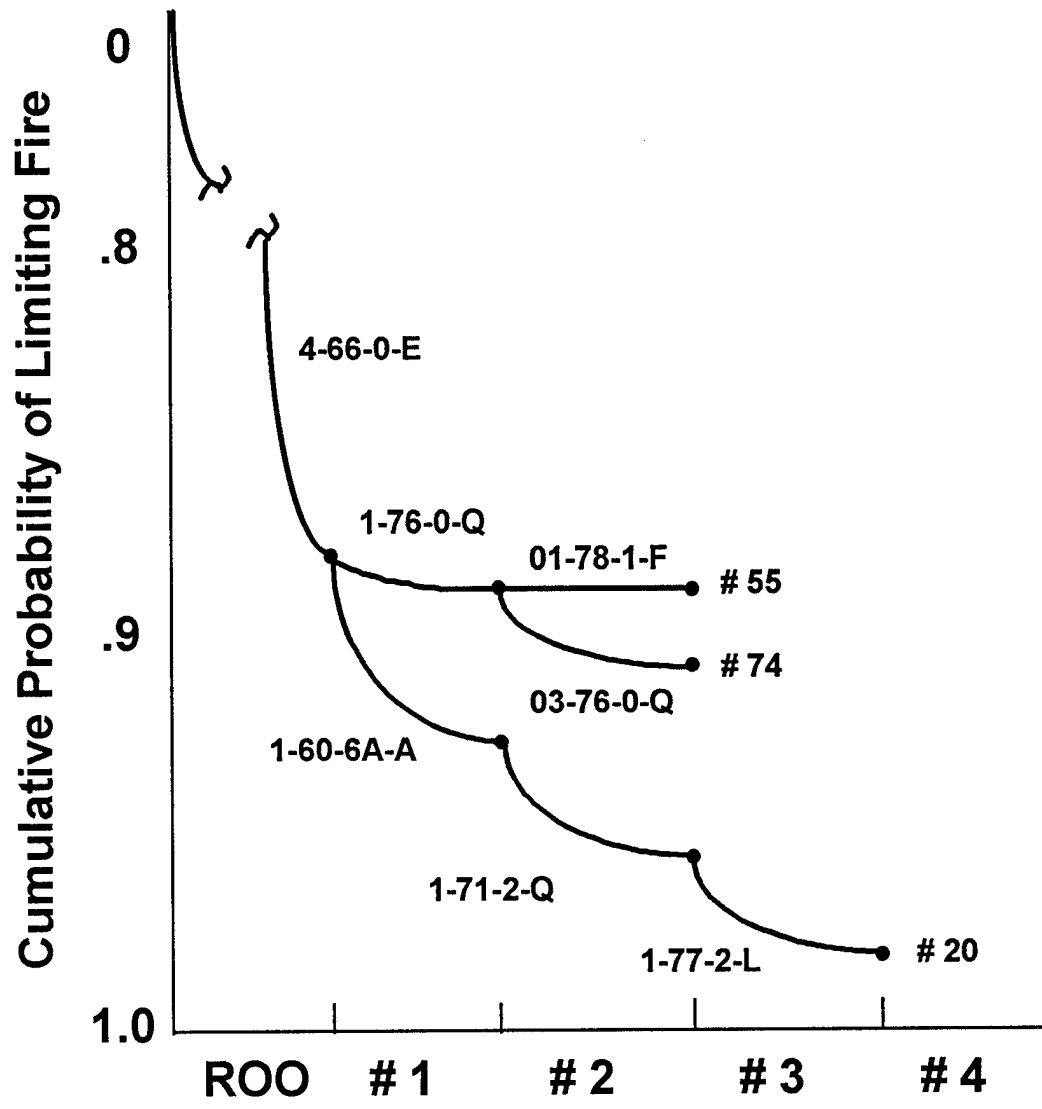

	ROO	# 1	# 2	# 3	# 4
Time to EB Path # 55 (minutes)	0	3	5		
Time to EB Path # 74 (minutes)	0	3	4		
Time to EB Path # 20 (minutes)	0	6	6	6	

Figure 3.3 Envelope of L-curve of Fire Paths from 4-66-0-E

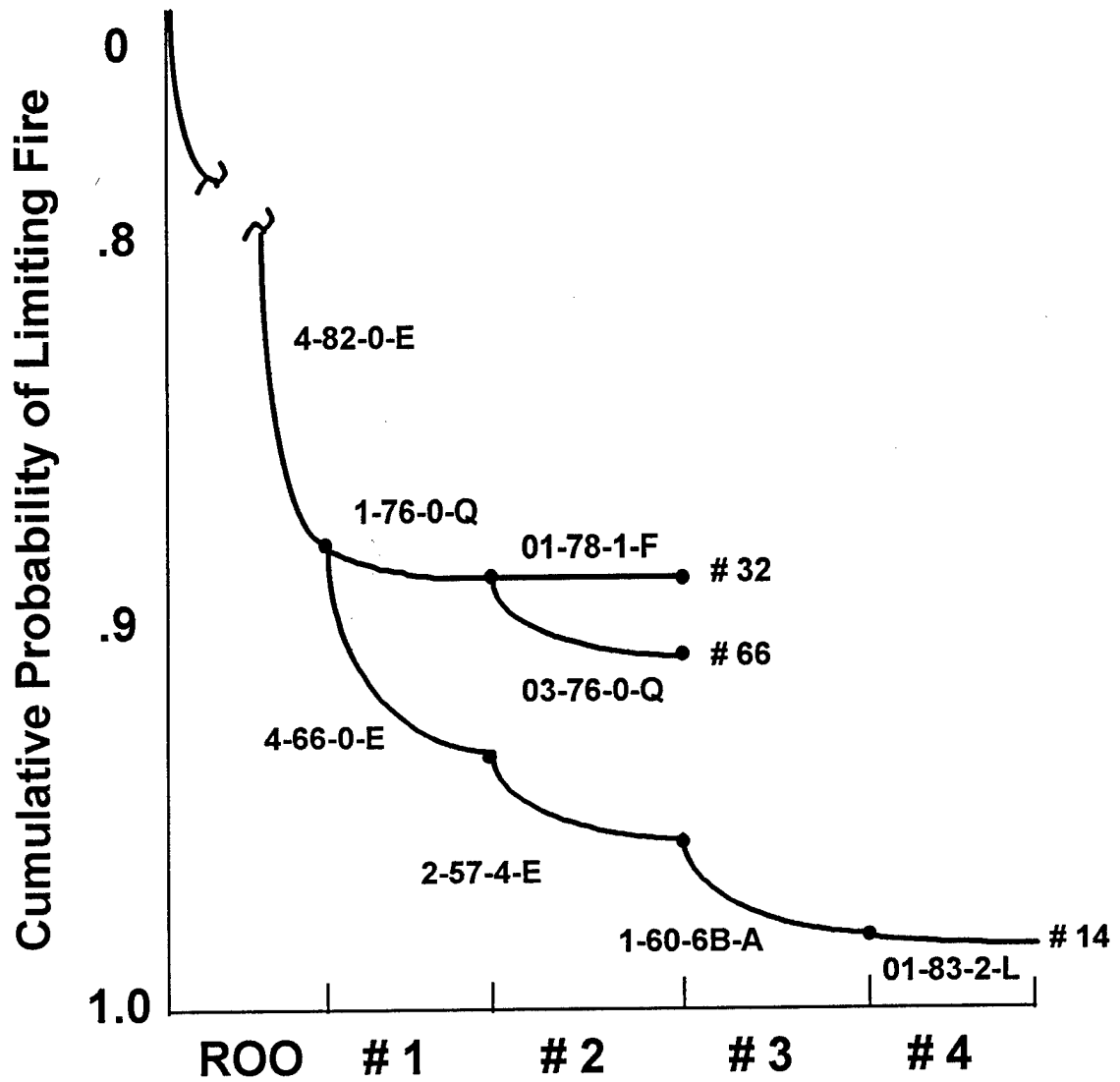

	ROO	# 1	# 2	# 3	# 4
Time to EB Path # 32 (minutes)	0	5	8		
Time to EB Path # 66 (minutes)	0	5	7		
Time to EB Path # 14 (minutes)	0	7	12	16	18

Figure 3.4 Envelope of L-curve of Fire Paths from 4-82-0-E

By plotting the L-curve for the highest and the least cumulative probability of limiting the fire, an "envelope" of L-curves is shown that brackets all the L-curves for the room of origin which may include dozens of additional fire paths. Figures 3.1 through 3.4 show the L-curves that were constructed for the five selected rooms of origin. Note the L-curve for the Cargo Hold is not shown because the fire did not spread to an adjacent compartment within the 60 minutes specified in the scenario. The following discussion presents observations from an analysis of the path option results illustrated by the L-curves shown in Figures 3.1 through 3.4

Each graph shows the cumulative probability of limiting the fire on the ordinate axis and the sequential rooms in the fire path on the abscissa axis. The room of origin is always shown as the first room in the path. Thus the probability of limiting the fire in the room of origin is the first data point plotted along the curve starting from zero at the top left of the graph. The vertical bar (e.g. from .7 to .9 in Figure 3.1) is a graphical illustration of the strength of the barrier between compartments 1-85-3-L and 1-92-1-L. Therefore as shown in Figure 3.1, there is a 70% probability that the fire will be limited in 1-85-3-L (the room of origin). There is a 20% probability that the barrier in 1-85-3-L will prevent the fire from spreading to 1-92-1-L. Finally there is a 98% probability that the fire will be limited somewhere along this path by the time 60 minutes elapses. Note that established burning will occur at minute 48 in 1-92-1-L if it is assumed that EB occurs at minute 0 in the room of origin. No other L-curve is drawn since the results from the path option show this to be the only potential fire path from this room of origin.

Figure 3.2 also shows a single fire path. The path option results indicate 10 potential paths from the Bow Thruster Machinery Room, 4-12-0-E, with cumulative probabilities that vary from 98% to 95% on paths that involve rooms other than 4-12-0-E. The envelope of L-curves is thus so narrow that it loses its significance other than to indicate that all fire paths are approximately equal in probability of limiting the fire. Therefore engineering judgment was used to select the fire path for plotting an L-curve that is considered most appropriate for constructing realistic fire drills. Figure 3.2 also shows no vertical bars between rooms in the fire path. There are two possibilities for a barrier to exhibit zero strength:

- Due to relatively short FRI times and high heat release rates in the compartment, the barrier experiences a Dbar or Tbar failure within the first minute of the compartment reaching FRI. SAFE analyzes the Tbar/Dbar curves once every minute. An open door is automatically a Dbar failure as is a zero strength barrier (such as between Two segments of a long passageway).
- The fire spreads into two or more rooms simultaneously through a common barrier, this is frequently the case when time to EB is identical for the spaces involved.

Examining the time to EB and a drawing of the spaces and how they adjoin will resolve the issue. For example the drawing will show a door if one exists and Table B.2 will specify whether the door is normally open or what DC classification is assigned. As shown in Figure 3.2 the room of origin will contain the fire for 16 minutes. Since EB occurs in both succeeding rooms in this path in 16 minutes and there is no door between them, the common barrier must have failed. In this case the overhead of the Bow Thruster Machinery Space fails, starting EB in the AFFF Station (1-18-2-Q) and the ATON Storeroom (1-18-4-A) simultaneously at minute 16.

Figure 3.3 shows an envelope of L-curves for fire paths from the Main Machinery Room, 4-66-0-E, as the room of origin. The path with the least probability of limiting the fire starts in

4-66-0-E, spreads to the Main Machinery Room Uptake, 1-76-0-Q, and then to the Emergency Generator Service Tank, 01-78-1-F, with EB occurring in 01-78-1-F in 5 minutes. A full service tank will act as a heat sink thus preventing failure of this barrier for a considerable period of time (not accounted for in SAFE). A partially empty tank would be especially dangerous in this scenario. This illustrates how an analysis using the SFSEM must be considered carefully when interpreting the results.

The plot of the L-curve with the highest probability of limiting the fire from 4-66-0-E shown in Figure 3.3 indicates that EB occurs in 6 minutes in 1-60-6A-A, 1-71-2-Q, and 1-77-2-L simultaneously. This is an indication that the fire spread into these compartments through a common barrier. A review of the Main Deck plan in Appendix A shows the common barrier to be the deck in these compartments (which is the overhead of 4-66-0-E in this area of the ship). Another slightly less likely scenario shown in Figure 3.3 is a fire that breaks into the Dry Provision Storeroom (1-60-6A-A), the Engineering Log Office & DC Central (1-71-2-Q), and the CPO Mess & Lounge (1-77-2-L) simultaneously in 6 minutes. These scenarios provide the envelope of the 81 potential fire paths from the Main Machinery Room shown in the path option results.

Figure 3.4 illustrates the envelope of L-curves for fire paths from The Auxiliary Machinery Room, (4-82-0-E). The fire path with the least probability of limiting the fire is similar to the fire path shown in Figure 3.3 from the Main Machinery Room once the fire reaches the Main Machinery Room Uptake. It is interesting to note that the fire path from the Auxiliary Machinery Room will result in EB in the Stack (03-76-0-Q) in 7 minutes with a 90% probability of limiting the flame compared to EB in the Emergency Generator Service Tank in 8 minutes with a 88.5% probability of limiting the flame. In other words while there is only a 1.5% difference in the probability of limiting the flame but there is 14% more time available for the fire party to respond (8 minutes compared to 7). It is very important to give equal consideration to both "time to EB" and "probability of extinguishing the fire" because ability to extinguish the fire is extremely sensitive to time. Therefore even though the path leading to the Emergency Generator Service Tank may be the most probable path of fire spread, the path leading to the Stack may be the most dangerous. It would be prudent to train fire parties to respond to both scenarios. Conclusions drawn from this analysis are based on small differences in results but it serves to illustrate the point.

3.3.7. CONDUCT COST-BENEFIT ANALYSIS

The goal of the fire safety analysis is to maximize the benefit (improvement in fire safety), while minimizing the costs (dollars and other intangible factors) of the changes. A cost-benefit analysis is thus considered an important part of alternative design evaluation. Within the constraints of time and allowable funds, as many alternatives as possible are studied to permit a useful cost-benefit analysis. Since all compartments in the WLB (R) exceed FSOs by a substantial margin, no improvements are required to bring the ship up to minimally acceptable standards. Accordingly, a cost-benefit analysis of alternatives is not applicable for the WLB (R).

3.3.8. DOCUMENT RESULTS

This report contains comprehensive results and provides the basis of assumptions and estimates when complete or factual information was not available. The appendices present the

input data and detailed output results. Additional insight may be gained by referring to the other technical reports and documents referenced throughout this report.

4. FIRE PROTECTION DOCTRINE

4.1. BACKGROUND

4.1.1. MAIN SPACE FIREFIGHTING DOCTRINE

The Main Space Firefighting Doctrine, published as Commandant Instruction M9555.1, applies to class B fires in the machinery spaces on all Coast Guard cutters 65' and greater in length. [26] The purpose of this doctrine is to delineate the tactics, philosophy, and procedures associated with the use and operation of the various firefighting systems and equipment on board the cutter for combating machinery space fires. The doctrine is structured to provide a basis for the proper actions and decisions of the firefighting crew and the considerations necessary in choosing the correct firefighting equipment and agent. The doctrine also defines personnel responsibilities and scenarios such as a major oil leak which could result in a class B fire.

The main space firefighting doctrine for Coast Guard cutters was written in a general manner to apply to all floating units. It was designed primarily for the larger cutters; all cutters were supposed to tailor the doctrine to suit their individual needs. The doctrine is difficult to tailor because crew sizes, state of training and installed firefighting equipment vary considerably in the Coast Guard fleet. Finally, the format of the doctrine was organized such that general information pertaining to fire science, guidance from the Commandant and other authorities, and specific tactical procedures for a particular cutter were mixed throughout the document. Consequently, an objective of the SCFP project was to provide a firefighting doctrine designed primarily for the needs of the small cutter. This objective was achieved by expanding the scope of the doctrine to include procedures for all classes of fire in all types of compartments and reformatting the doctrine into three parts. The new doctrine was designed to be applicable to small as well as large Coast Guard cutters as will be discussed in the following sections which describe the new fire protection doctrine.

4.1.2. FIRE PROTECTION DOCTRINE

Ten classes of small Coast Guard cutters were analyzed in the SCFP project. A fire protection doctrine was developed and tailored for each class of cutter; only minor changes are required for each cutter in the class to account for uncompleted SHIPALTS, changes in compartmentation due to different subclasses, etc. The format of the new doctrine is significantly different than the format of the Main Space Firefighting Doctrine. The following sections describe the format and scope of the new fire protection doctrine as well as procedures for maintaining this document.

4.1.2.1. Fire Protection Doctrine Format

The new fire protection doctrine is organized into three parts. Part A includes information and facts concerning fire science and firefighting such as the effectiveness of various firefighting agents on the different classes of fires. This part applies equally to all cutters (large and small) and rarely changes over time. The development of a new

firefighting agent would be an occasion worthy of updating Part A. Note this revision would not require the use of that agent on any particular ship.

Part B incorporates guidance promulgated by the Commandant, U. S. Coast Guard. The format of this new doctrine calls for two different versions of Part B - one applicable to small cutters (less than 180' in length) and the other applicable to large cutters (180' and greater in length). This distinction is based on several factors including crew size, type of hazard due to main propulsion equipment, quantity and timeliness of firefighting support likely to be available, and expected area of operations. At the Commandant's discretion, portions of Part B may be similar for both large and small cutters. Circumstances for activating a gas turbine enclosure local fire extinguishing system is an example of guidance the Commandant would provide in Part B for large cutters only since gas turbines are not used on small cutters. On the other hand, since small cutters are generally able to safely abandon ship due to their proximity to shore, the Commandant may provide guidance of when that would be appropriate for small cutters only.

Part C contains the tactical procedures to combat all classes of fires, in all types of compartments, in port and at sea. This part is developed for a representative cutter for each class. Other cutters in the class will have to tailor this part to account for uncompleted (or unauthorized) SHIPALTS and other differences that would require different tactics. **The Commanding Officer of the cutter has the responsibility to ensure this tailoring is accomplished in a timely manner and that such changes do not contradict the guidance provided in Parts A and B.**

4.1.2.2. Scope

This report provides a tailored fire protection doctrine, documented in Appendix E of this report, for the WLB (R). Part A of the fire protection doctrine, included in Appendix E to this report was previously developed as part of the SCFP. Part B was originally developed in conjunction with the CGC VINDICATOR fire safety analysis project. [9] Part C of the fire protection doctrine was specifically developed as part of this WLB (R) fire safety analysis project.

The fire protection doctrines developed for small cutters previously studied in the SCFP included firefighting procedures for every accessible compartment. This approach is impractical for the much larger WLB (R) due to the fact there are 134 accessible compartments in the cutter. The individual compartments selected for development of firefighting procedures were therefore limited to fifteen compartments. The following criteria was used to select these fifteen compartments:

- Firefighting procedures for each class of fire and typical combination of classes are desired in the doctrine
- Access or egress routes may not be immediately obvious for certain compartments
- Unusual firefighting tactics may be necessary to deal with conditions that exist in the compartment

- The compartment has a relatively high historic frequency of EB
- The fuel loads or fuel load densities are considered relatively high compared to other compartments
- Compartments designated as engineering spaces
- Compartments with automated fire protection systems installed
- Compartments which have relatively high RLFs in the Baseline Fire Safety Analysis
- Compartments which are considered critical to the ship's primary missions

4.1.2.3. Future Revisions

Part A of the doctrine presents the principles of fire science that pertain to shipboard firefighting and other factual information to enable a crew member to make the proper selection of firefighting equipment and fire suppression agents to combat a particular class of fire. Revisions to this part should rarely be required. The introduction of a new firefighting agent or equipment by industry is the most likely scenario that would require updating Part A. This revision is necessary if the new agent or equipment is used somewhere in the Coast Guard fleet.

Part B represents guidance from the Commandant and other Naval authorities applicable to either large cutters or small cutters. Recent conflagrations on the USS STARK and USS ROBERTS provided many lessons learned; these fires are examples of scenarios that would likely result in new or additional guidance provided to the fleet.

Changes to Part C will usually be required in the event of SHIPALTS that affect the firefighting capabilities or compartmentation of the Cutter. In addition, new Commanding Officers are likely to change Part C (within the constraints of Parts A and B) due to their own beliefs, experiences, and desires.

It is expected that the Commandant, U.S. Coast Guard will issue revisions to Parts A and B as necessary, while Commanding Officers will be responsible for revising Part C for their own cutter. The revision page of the doctrine should document the authority who issued the change.

4.2. FIRE PROTECTION DOCTRINE FOR THE WLB (R)

As noted above, Part C of the doctrine contains ship specific information relative to firefighting procedures on the WLB (R). This part of the doctrine was based on information collected during a ship visit to the JUNIPER, the lead cutter in the WLB (R) class. The ship visit was planned for two days and later shortened to one day due to scheduling conflicts. Therefore information in the doctrine is partially based on written information provided by the ship. Much of this information could not be verified for accuracy during the ship visit. Moreover lead cutters are frequently different than follow-on cutters in the class in areas such as compartmentation, installed equipment and outfitting. In fire protection terms this translates to different fuel loads, ignition sources, and potential fire scenarios. Consequently the JUNIPER should verify the accuracy of the

information in Part C of the doctrine prior to implementing it on the ship. In addition follow-on cutters in the WLB (R) class should tailor the doctrine to account for differences between themselves and the JUNIPER.

Due to the large number of compartments on this cutter, there was a need to reduce the number of individual scenarios to a reasonable number that would be described in Part C. Compartments to be included in Part C were identified by applying the criteria discussed in section 4.1.2.2 and shown in Table 4.1. The 15 compartments shown as rows in this table fit many of the criteria shown as columns and were thus selected for inclusion in Part C.

Table 4.1
 Compartments for Inclusion in Part C of the Fire Protection Doctrine

	FF procedures for each class of fire	Access or egress problems	Unusual FF tactics	High frequency of EB	High fuel load or fuel load density	Engineering spaces	Automated fire protection systems	Relatively high RLFs in baseline	Mission critical spaces
03-56-0-C	PILOT HOUSE	A/C							X
02-57-0-L	CO CABIN	C			X			X	
02-73-0-Q	FAN ROOM	A				X	X	X	
01-78-3-E	EMERGENCY GENERATOR ROOM	B		X		X	X		X
4-66-0-E	MAIN MACHINERY ROOM	B		X		X	X		
2-30-0-AA	CARGO HOLD	A					X		X
03-66-01-C	ELEX IC & GYRO ROOM	C						X	
4-82-0-E	AUXILIARY MACHINERY ROOM	B		X		X	X	X	X
4-92-0-E	STERN THRUSTER MACHINERY ROOM	C				X	X		X
4-12-0-E	BOW THRUSTER MACHINERY ROOM	C				X	X		X
2-49-0-E	SOR MACHINERY ROOM	B				X	X		X
1-102-0-E	STEERING GEAR ROOM	B				X	X		X
1-57-1-Q	GALLEY	B							X
1-105-2-Q	LAUNDRY	A			X				
1-6-2-A	FLAMMABLE LIQUID STOREROOM	B			X		X		

5. CONCLUSIONS AND RECOMMENDATIONS

This report describes the results of the fire safety analysis of the WLB (R). An interim report discussing the results of the preliminary baseline fire safety analysis was submitted but is not generally available in the literature, however it may be available upon request from the Safety and Human Resources Division, U. S. Coast Guard Research and Development Center [27]. Since this document is the final report in the project, the conclusions and recommendations presented herein include or modify those presented in the interim report. The two major objectives established for this project include the performance of a detailed fire safety analysis and development of a comprehensive fire protection doctrine for the WLB (R). This section of the report is organized in a manner that corresponds to these objectives.

5.1. FIRE SAFETY ANALYSIS

The most important objective in this project was to analyze the fire safety of the WLB (R). As the twelfth cutter to be analyzed using the Ship Fire Safety Engineering Methodology (SFSEM) in the past five years, fire safety analysis results for the WLB (R) may be compared to the results of the ten previously analyzed cutters in the Small Cutter Fire Protection Project and the VINDICATOR. [3, 9] Baseline results in the SCFP and VINDICATOR indicate that fire protection levels in most compartments, with passive, automated and active fire protection features in effect, generally meet Fire Safety Objectives (FSO). Results of the baseline fire safety analysis of the WLB (R) are consistent with the results discussed in the SCFP and VINDICATOR final reports and are in agreement with historical records for medium endurance cutters which are comparable in length and complexity to the WLB (R).

The following sections describe the conclusions and recommendations of the preliminary and baseline fire safety analyses.

5.1.1. PRELIMINARY FIRE SAFETY ANALYSIS

The preliminary analysis was limited in scope since it was not possible to visit the ship to collect actual data. Instead, information was taken from the ship's drawings and the COR, in addition default values were used for many of the input parameters in SAFE. The following conclusions and recommendations can be made in conjunction with the preliminary baseline analysis:

- In general, this cutter is very well protected with automated and manual fire protection systems that include bilge and overhead AFFF sprinkling systems, water sprinkling systems, and CO₂ total flooding systems. As shown in Table B.5, some compartments are protected with two automated systems. The galley stove and deep fat fryer are protected by an aqueous potassium carbonate system. Portable CO₂ and PKP fire extinguishers are located throughout the cutter. Finally firemain stations are installed throughout the cutter and include AFFF reentry hose stations.
- The WLB (R) is equipped with a well designed and comprehensive fire and smoke automatic detection system. The majority of accessible spaces are protected by at least one detector and many compartments have multiple detectors. The types of detectors installed are considered appropriate for the fire threat. Coupled with

multiple and convenient ways to contact the Pilothouse, the time to detection on this cutter is minimized compared to other Coast Guard cutters and is considered excellent.

- The WLB (R) is planned for operation with a minimal crew (40 crew members). The crew's ability to perform preventive maintenance is thus limited. Unfortunately the WLB (R) is equipped with many automated systems to support a minimal crew and these systems actually increase the preventive maintenance requirements. Very high vibration levels were reported which tend to adversely affect the reliability of automated equipment.
- As in all previous cutter firesafety analyses, fire growth models for the WLB (R) were selected that most closely represent conditions observed and documented in Appendix B, Table B.8. There is some concern that the alpha and Qmax thus assigned to some compartments based on the selected fire growth model, may be higher than the observed fuel loads would justify. In general, high alpha and Qmax values would result in short FRI times and therefore higher relative loss factors would be expected. In other words, the results in some compartments may indicate a more dangerous condition than actual fuel load characteristics would warrant.
- Preliminary Baseline Analysis results with the individual target option show that all compartments exceed fire safety objectives (FSO) with passive, automated and manual fire protection in effect. The baseline data set was subsequently changed As a result of better information collected during the JUNIPER ship visit. The baseline analysis revealed that results from the preliminary baseline based on default values indicated the ship was safer than actual conditions would warrant. Fuel loads, ventilation details and probabilities of flame termination were changed significantly based on actual data collected during the ship visit.

5.1.2. BASELINE FIRE SAFETY ANALYSIS

Based on a comprehensive fire safety analysis, all compartments in the WLB (R) meet FSOs by a substantial margin with passive, automated, and manual fire protection features in effect. Without considering the contribution provided by manual firefighting efforts, the WLB (R) meets FSOs in every compartment (just passive and automated fire protection in effect). However, without considering the contribution provided by automated fire suppression (I and M only), the WLB (R) fails to meet FSOs in 4 compartments with one other compartment marginally acceptable. Ten compartments fail to meet FSOs with just passive fire protection in effect, and several others are close to failing FSOs. Therefore passive fire protection must be augmented by automated fire suppression for the WLB (R) to meet FSOs in all compartments.

Based on historical records, the other classes of U.S. Coast Guard Medium Endurance Cutters had a frequency of reportable fires equal to 1 reportable fire every 10.3 years based on 134 cutter years of data (34 ships over 4 years). Therefore, relatively high fire safety levels are expected in cutters of this length and complexity.

Based on a thorough baseline fire safety analysis using the target option as well as the barrier and path options in SAFE, the following additional conclusions and recommendations are offered:

- The minimal crew size on this cutter is feasible due to the installation of a sophisticated and comprehensive fire and smoke detection system and the installation of appropriate and in some cases redundant automated fire extinguishment systems. However the crew must receive support in accomplishing the preventive maintenance to ensure the reliability of the equipment and systems they are relying upon.
- The planned inport duty section size (5 crew members) has an adverse effect on in port fire safety even though in port fire safety in every compartment meet fire safety objectives. The crew on this cutter is dependent on automated fire protection systems and outside assistance to combat major fires in port.
- The most probable path of fire spread may not necessarily be the most dangerous. A careful analysis of the results from the various options in SAFE can be effectively used to develop realistic fire scenarios to assist the crew in planning fire drills.
- The installation of AFFF portable fire extinguishers is considered an excellent and appropriate addition to combat small class B fires on this cutter.
- The large hatch covers should be retrofitted with a spring loaded device to enable a single crew member to easily open and secure the hatch.
- The existing fire detector in the Steering Gear Room should be relocated closer to the hazard and additional detectors in adjacent pockets of the overhead would improve the probability of early fire detection in this space.

5.2. FIRE PROTECTION DOCTRINE

The second objective in this project is the development of a tailored fire protection doctrine for the WLB (R). The new doctrine, submitted in its entirety with this report as Appendix E, describes procedures and tactics for combating all classes of fire in all types of compartments. The doctrine is in consonance with official Coast Guard policy published in the Naval Engineering Manual [4], and other official publications such as the Naval Ships' Technical Manuals [5, 6]. In addition, it incorporates approved recommendations and comments from Coast Guard Headquarters received in response to the interim technical reports previously submitted in the SCFP.

This doctrine reflects information taken from the Main Machinery Space Fire Protection Doctrine (JUNIPER Instruction 9555.1). [24] This Instruction is assumed to be accurate; time constraints during the ship visit precluded verification of the information. **Due to these assumptions and retrofits that frequently occur on new ships, it is imperative that the factual information in this doctrine be updated, based on a thorough ship-check by the crew, prior to using this doctrine for training or indoctrination of the crew.** Due to incomplete information, certain portions of Part C of the new fire protection doctrine are necessarily incomplete. For example the location of AFFF extinguishers is unknown at this time because they are being installed as they are received. Missing information should be included during the ship check discussed above.

REFERENCES

1. WLB (R) Seagoing Buoy Tender Circular of Requirements, Published by Commandant, U.S. Coast Guard, August 12, 1994.
2. Sprague, Chester M., "Theoretical Basis of the Ship Fire Safety Engineering Methodology", Prepared for the U.S. Coast Guard Research and Development Center, Safety and Human Resources Division, 1082 Shennecossett Road, Groton, CT 06340-6096, July 1992.
3. Sprague, Chester M., "Small Cutter Fire Protection Project", 2 Volumes, CompuCon, R&DC Report No. 13/94, Prepared for the U.S. Coast Guard Research and Development Center, Marine Fire and Safety Research Branch, 1082 Shennecossett Road, Groton, CT 06340-6096, November, 1994.
4. "Naval Engineering Manual," Commandant Instruction M9000.6B, Change 1, U.S. Department of Transportation, U.S. Coast Guard, May, 1994.
5. Naval Ships' Technical Manual, S9086-S3-STM-010, Chapter 555, "Shipboard Firefighting", First Revision, Author/Sponsor: Naval Sea Systems Command, 1 June 1993.
6. Naval Ships' Technical Manual, NAVSEA 0901-LP-079-0010, Chapter 079, "Damage Control, Stability and Buoyancy", Author/Sponsor: Naval Sea Systems Command, 15 August 1976.
7. Clouthier, Elizabeth; Rich, Doris; and Romberg, Betty, "SAFE User Manual Version 2.2, A Computer Model for the Implementation of The Ship Fire Safety Engineering Methodology", CompuCon, Prepared for the U.S. Coast Guard Research and Development Center, Safety and Human Resources Division, 1082 Shennecossett Road, Groton, CT 06340-6096, March, 1996.
8. Richards, Robert C., "Fire Safety Analysis of the Polar Icebreaker Replacement Design", 3 Volumes, Report No. CG-M-04-88, October, 1987.
9. Sprague, Chester M. and LT Dolph, Brian, "Fire Safety Analysis of the USCGC VINDICATOR (WMEC 3)", Technical Report, Prepared for the U.S. Coast Guard Research and Development Center, Marine Fire and Safety Research Branch, 1082 Shennecossett Road, Groton, CT 06340-6096, June, 1995.
10. Sprague, Chester M., "Fire Safety Analysis of Three Small Coast Guard Cutter Classes", CompuCon, 4 Volumes, Interim Technical Report, Prepared for the U.S. Coast Guard Research and Development Center, Marine Fire and Safety Research Branch, 1082 Shennecossett Road, Groton, CT 06340-6096, July, 1992.
11. Holmstedt, Herbert A., "Fire Safety Analysis of Six Small Coast Guard Cutter Classes", 7 Volumes, CompuCon, Technical Report, Prepared for the U.S. Coast Guard Research and Development Center, Marine Fire and Safety Research Branch, 1082 Shennecossett Road, Groton, CT 06340-6096, September, 1993.
12. Sprague, Chester M.; Holmstedt, Herbert A.; Romberg, Betty; and Dolph, Brian, "Fire Safety Analysis of the 175' WLM (R) Coastal Buoy Tender", Report No. 35/94,

Prepared for the U.S. Coast Guard Research and Development Center, Marine Fire and Safety Research Branch, 1082 Shennecossett Road, Groton, CT 06340-6096, December, 1994.

13. "Surface Ship Survivability Manual", Naval Warfare Publication 62-1 (Rev C), December, 1989.
14. Engineering Casualty Control Manuals, U.S. Department of Transportation, U.S. Coast Guard. (A separate Casualty Control Manual exists for each CG Cutter.)
15. "Vessel Safety Manual", North Pacific Fishing Vessel Owner's Association, Editor: John Sabella, 1986.
16. "Marine Fire Prevention, Firefighting and Fire Safety", Maritime Administration, U.S. Department of Commerce, Maritime Training Advisory Board, Published by the Robert J. Brady Co. for the National Maritime Research Center, 1979.
17. Bahadori, Hamid, "A Quantitative Procedure for Fire Risk Assessment of U.S. Coast Guard Vessels", Master's Thesis, submitted to Worcester Polytechnic Institute, October 1987.
18. Bahadori, Hamid, Beyler, Craig, Richards, Robert, and Romberg, Betty, "Using the Ship Fire Safety Engineering Methodology with Mission Oriented Objectives", Draft Paper, Center for Firsafety Studies, Worcester Polytechnic Institute, June 1991.
19. Peatross, Michelle, Beyler, Craig, and Back, Gerry, "Validation of Full Room Involvement Time Correlation Applicable to Steel Ship Compartments", Hughes Associates, Inc, Report No. 1117-001-1993, 1993.
20. Nash, Louis, Cummings, W. Mark, and Sprague, Chester M., "Fire Safety Analysis of the U.S. Coast Guard Cutter VIGOROUS, FP 570 Fire Protection Analysis", MFRB Technical Note 1056, prepared for U.S. Coast Guard Research and Development Center, Marine Fire and Safety Research Branch, 1082 Shennecossett Road, Groton, CT 06340-6096, December, 1990.
21. Sprague, Chester M., "Analysis of the Cutter Standard Repair Locker Inventory", CompuCon, Letter Report, Prepared for the U.S. Coast Guard Marine Safety Laboratories, December, 1990.
22. Sprague, Chester M., "Preliminary Fire Safety Analysis of Three Small Coast Guard Cutters", CompuCon, Interim Technical Report, Prepared for the U.S. Coast Guard Marine Safety Laboratories, June, 1991.
23. Dolph, Brian, "Main Vertical Fire Zone Evaluation", Prepared for U.S. Coast Guard Research and Development Center, Marine Fire and Safety Research Branch, 1082 Shennecossett Road, Groton, CT 06340-6096, Date ?.
24. Machinery Space Firefighting Doctrine for Class Bravo Fires, CGC JUNIPER Instruction M9555.1, undated.
25. Compartment Check-Off Lists for the Seagoing Buoy Tender, Prepared by Marinette Marine Corporation, November 29, 1995

26. Machinery Space Firefighting Doctrine for Class Bravo Fires, Commandant Instruction M9555.1, U.S. Department of Transportation, U.S. Coast Guard, June 15, 1989.
27. "Firesafety Analysis of the 225' Seagoing Buoy Tender, Preliminary Baseline Analysis Results", Unpublished Letter Report, Prepared for the U. S. Coast Guard Research and Development Center, Marine Fire and Safety Research Branch, December 21, 1995.

Appendix A

COMPARTMENTATION

This appendix includes outboard profile, inboard profile and plan views of all decks. The plan views include the access fittings for each compartment such as doors, scuttles, hatches, and operable windows. The compartmentation shown represents how the ship was modeled in AutoCAD for the fire safety analysis.

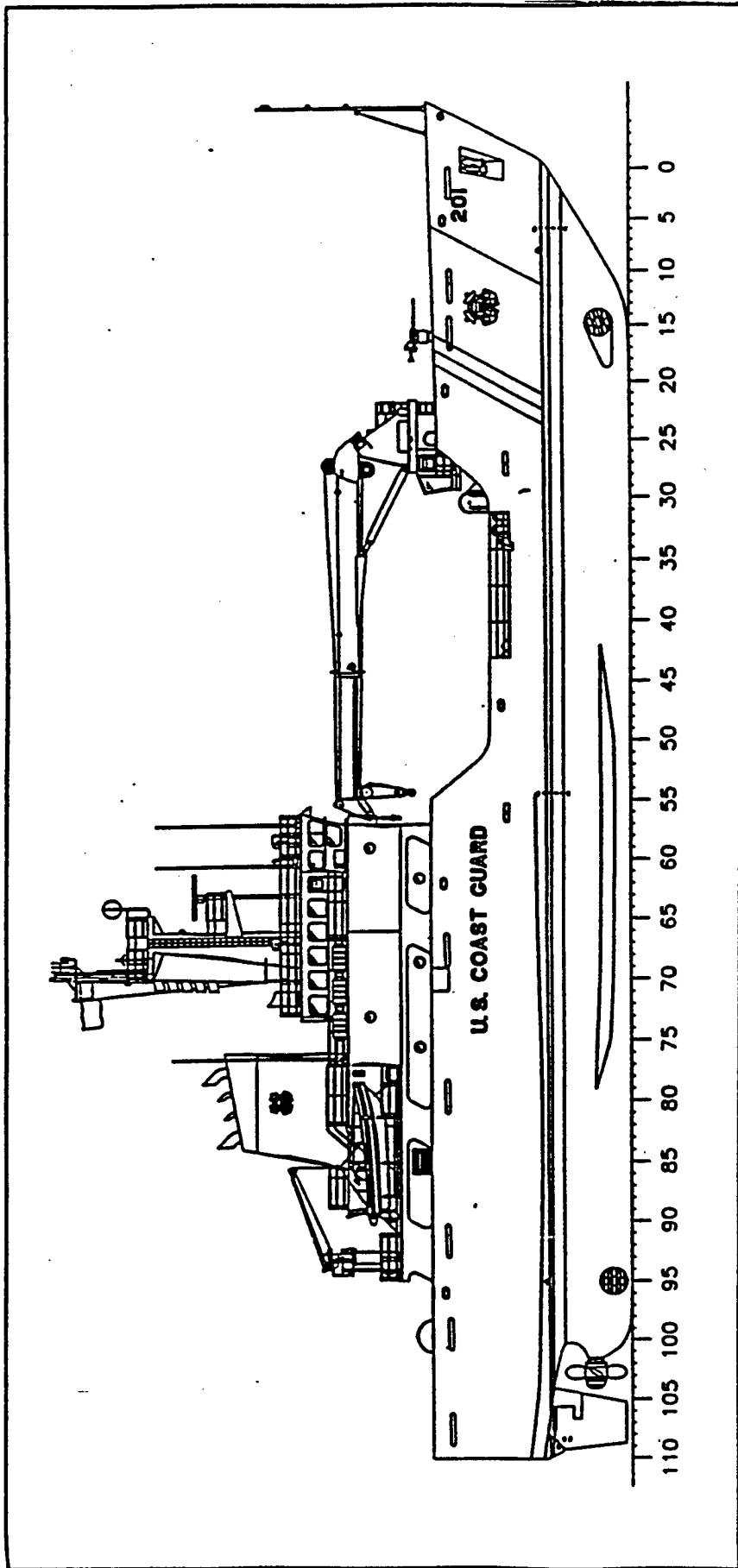

Figure 1. Outboard profile.

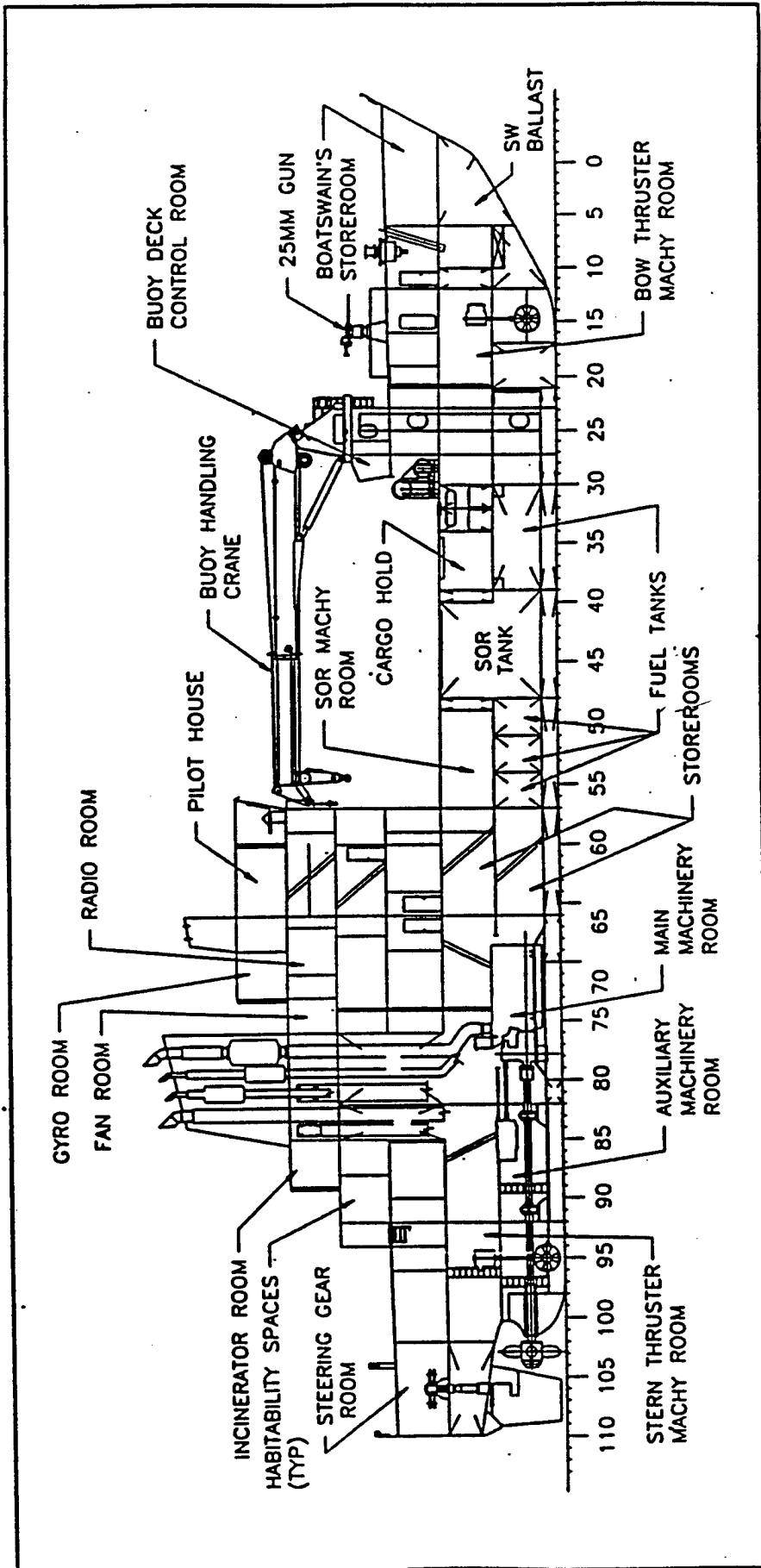
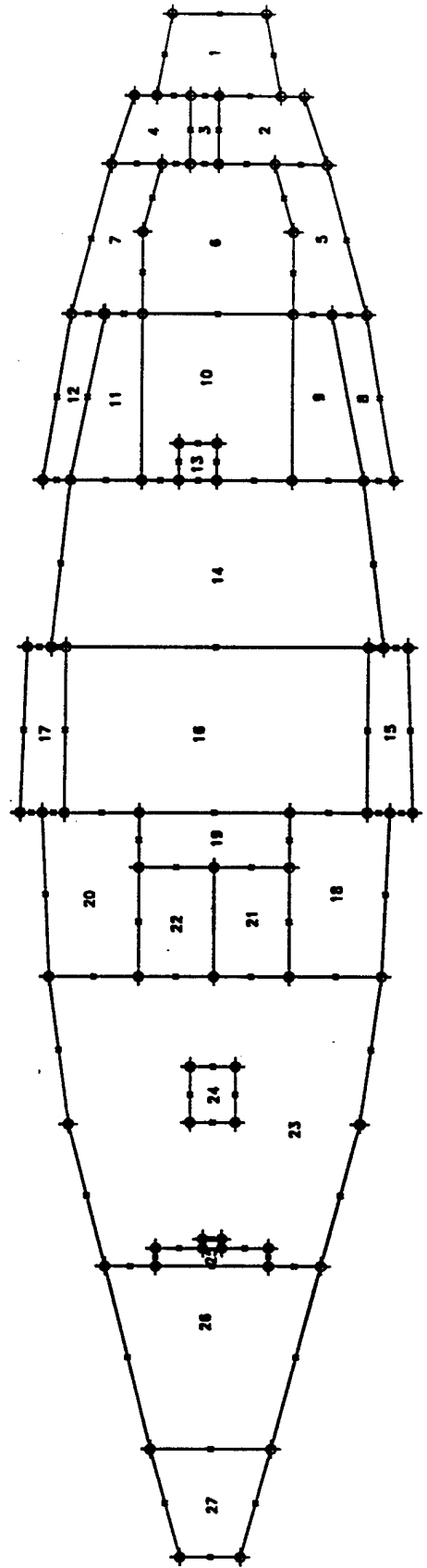

Figure 2. Inboard profile.

Plan ID	Compartment Name	Drawing Number
4-12-0-E	BOWTHRUSTER MCHRY ROOM	1
4-17-1-F	FUEL TANK	2
4-17-2-V	VOID	3
4-17-4-F	FUEL TANK	4
4-21-0C-W	SW BALLAST TANK	5
4-21-0B-W	SW BALLAST TANK	6
4-21-0A-W	SW BALLAST TANK	7
4-30-3-W	SW BALLAST TANK	8
4-30-1-F	FUEL TANK	9
4-30-0-F	FUEL TANK	10
4-30-2-F	FUEL TANK	11
4-30-4-W	SW BALLAST TANK	12
4-37-2-V	VOID	13
4-39-0-V	VOID	14
4-48-0C-W	SW BALLAST TANK	15
4-48-0B-W	SW BALLAST TANK	16
4-48-0A-W	SW BALLAST TANK	17
4-57-0C-W	SW BALLAST TANK	18
4-57-0B-W	SW BALLAST TANK	19
4-57-0A-W	SW BALLAST TANK	20
4-60-1-F	LO DRAIN TANK	21
4-60-2-F	OILY WATER TANK	22
4-66-0-E	MAIN MACHINERY ROOM	23
4-71-0-F	WASTE OIL TANK	24
4-80-0-W	SEA BAY	25
4-82-0-E	AUXILIARY MACHINERY ROOM	26
4-92-0-E	STERN THRUSTER MACHRY ROOM	27

Bottom



BOTTOM

Plan ID	Compartment Name	Drawing Number
4-8-0A-W	SW BALLAST TANK	31
4-8-0B-W	SW BALLAST TANK	32
3-21-0-L	PASSAGE	33
3-23-0-Q	CRANE PEDESTAL	34
3-25-1-M	MAGAZINE NO. 1	35
3-25-2-M	MAGAZINE NO. 2	36
4-39-0C-V	VOID	37
3-39-0-FF	SOR TANK	38
4-39-0A-V	VOID	39
3-48-1-F	FUEL TANK	40
3-48-0-FF	CARGO FUEL TANK	41
3-48-2-F	FUEL TANK	42
3-51-0-V	VOID	43
3-54-0-F	FUEL OIL OVFL TANK	44
3-57-0-A	SUPPLY DEPT. STOREROOM NO. 2	45
3-61-1-F	FUEL SERVICE TANK	46
3-62-2-F	FUEL SERVICE TANK	47

Plan ID	Compartment Name	Drawing Number
4-12-0-E	BOWTHRUSTER MCHRY ROOM	1
4-17-1-F	FUEL TANK	2
4-17-2-V	VOID	3
4-17-4-F	FUEL TANK	4
4-21-0C-W	SW BALLAST TANK	5
4-21-0A-W	SW BALLAST TANK	7
4-30-3-W	SW BALLAST TANK	8
4-30-1-F	FUEL TANK	9
4-30-0-F	FUEL TANK	10
4-30-2-F	FUEL TANK	11
4-30-4-W	SW BALLAST TANK	12
4-37-2-V	VOID	13
4-48-0C-W	SW BALLAST TANK	15
4-48-0A-W	SW BALLAST TANK	17
4-57-0C-W	SW BALLAST TANK	18
4-57-0A-W	SW BALLAST TANK	20
4-66-0-E	MAIN MACHINERY ROOM	23
4-82-0-E	AUXILIARY MACHINERY ROOM	26
4-92-0-E	STERN THRUSTER MACHRY ROOM	27
4-0-0-W	SW BALLAST TANK	28
4-6-0C-W	SW BALLAST TANK	29
3-6-0-Q	CHAIN LOCKER SUMP	30

Innerbottom

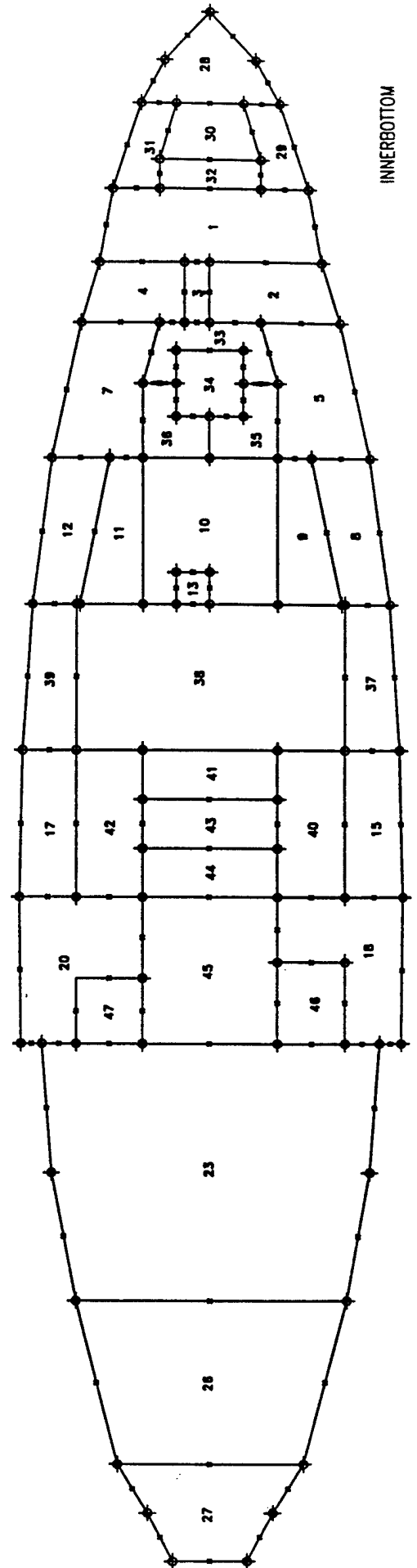

INNERBOTTOM

Plan ID	Compartment Name	Drawing Number
2-39-1-L	PASSAGE	60
2-39-0-V	COFFERDAM	61
2-39-2-V	VOID	62
2-48-1-L	PASSAGE	63
2-48-0-V	COFFERDAM	64
2-48-2-E	SOR PUMP ROOM	65
2-49-0-E	SOR MACHINERY ROOM	66
2-50-1-A	ENGINEER STOREROOM	67
2-53-1-L	VESTIBULE	68
2-57-1-Q	MACHINE SHOP	69
2-57-0-L	PASSAGE	70
2-57-2-A	SHIP STORE	71
2-57-4-E	WATER SUPPLY EQPT ROOM	72
2-59-1-Q	ELEC/ELEX WORKSHOP & STORER	73
2-89-1-C	ENGINEERING CONTROL CENTER	74

Plan ID	Compartment Name	Drawing Number
4-12-0-E	BOWTHRUSTER MCHRY ROOM	1
4-66-0-E	MAIN MACHINERY ROOM	23
4-82-0-E	AUXILIARY MACHINERY ROOM	26
4-82-0-E	STERN THRUSTER MACHRY ROOM	27
4-0-0-W	SW BALLAST TANK	28
4-6-0C-W	SW BALLAST TANK	29
4-6-0A-W	SW BALLAST TANK	31
3-23-0-Q	CRANE PEDESTAL	34
3-39-0-FF	SOR TANK	38
2-6-1-Q	CHAIN LOCKER	48
2-6-2-Q	CHAIN LOCKER	49
2-10-0-F	HYD OIL STG TANK	50
2-13-1-F	HPU RESERVOIR	51
2-13-2-F	HPU RESERVOIR	52
2-21-1-A	SUPPLY DEPT STOREROOM NO. 1	53
2-21-0-L	PASSAGE	54
2-21-2-Q	POTABLE WATER PUMP ROOM	55
2-25-1-WW	POTABLE WATER (CARGO)	56
2-25-2-W	POTABLE WATER (SHIP)	57
2-30-0-AA	CARGO HOLD	58
2-36-1-L	PASSAGE	59

1st Platform

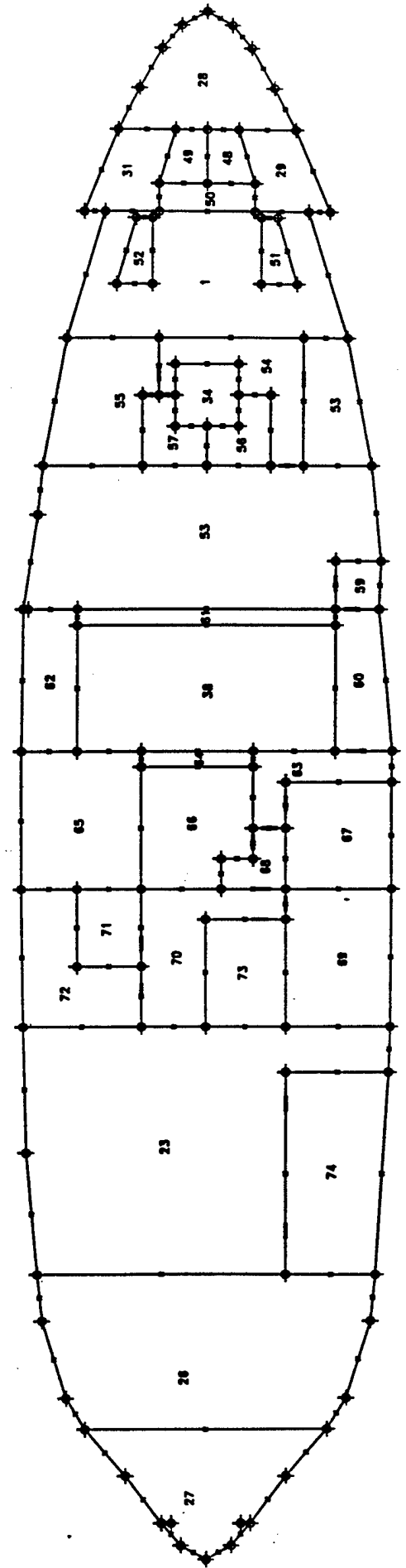

Main Deck

Plan ID	Compartment Name	Drawing Number
1-60-6A-A	DRY PROVISION STOREROOM	104
1-71-2-Q	ENG LOG OFFICE & DC CENTRAL	105
1-74-2-Q	DC REPAIR LKR NO. 2	106
1-76-0-Q	MMR (UPTAKE)	107
1-77-3-L	CREW LOUNGE	108
1-77-1-A	CREW LOCKER	109
1-77-2-L	CPO MESS & LOUNGE	110
1-80-1-E	VENT PLENUM	111
1-82-3-L	CREW WR, WC & SH	112
1-82-1-L	CREW WR, WC & SH	113
1-82-0-L	PASSAGE	114
1-82-2-Q	C.G. LKR W/ SINK	115
1-82-4-L	CREW WR, WC & SH	116
1-84-2-L	COMPANIONWAY	117
1-85-3-L	CREW SR	118
1-85-1-L	CREW SR	119
1-85-2-Q	AFF STA.	120
1-85-4-L	CREW SR	121
1-92-1-L	CREW SR	122
1-92-0-L	PASSAGE	123
1-92-2-L	CREW SR	124
1-96-1-L	CREW WR, WC & SH	125
1-96-0-L	CREW SR	126
1-97-2-Q	FAN ROOM	127
1-97-4-L	CREW WR, WC & SH	128
1-98-1-L	CREW WR, WC & SH	129
1-102-0-E	STEERING GEAR ROOM	130
1-102-2-A	DECK GEAR STOREROOM	131
1-105-2-Q	LAUNDRY	132



Plan ID	Compartment Name	Drawing Number
3-23-0-Q	CRANE PEDESTAL	34
1-0-0-A	BOATSWAIN STOREROOM NO. 1	75
1-6-1-A	BOATSWAIN STOREROOM NO. 2	76
1-6-2-A	FLAM. LIQ. STOREROOM	77
1-12-1B-L	PASSAGE	78
1-12-3-Q	BOATSWAIN SHOP	79
1-12-1A-L	PASSAGE	80
1-12-2-M	ARMORY	81
1-15-1-L	COMPANIONWAY	82
1-18-2-Q	AFF STA.	83
1-18-4-A	ATON STRM	84
1-18-1-Q	D.C. REPAIR LKR NO. 1	85
1-19-2-T	ESC TRUNK	86
1-21-3-L	COMPANIONWAY	87
1-21-1-L	VESTIBULE	88
1-21-2-Q	ATON SHOP	89
1-57-1-Q	GALLEY	90
1-57-3-Q	DUMBWAITER TRUNK	91
1-57-0-L	DECK WR & WC	92
1-57-2-L	PASSAGE	93
1-57-4-Q	CHANGE ROOM	94
1-59-2-L	COMPANIONWAY	95
1-60-1-L	GALLEY WR & WC	96
1-60-2-A	CHILL STRM	97
1-60-4-A	FREEZE STRM	98
1-60-6B-A	DRY PROVISION STOREROOM	99
1-66-3-Q	SCULLERY	100
1-66-1-Q	GALLEY ANNEX	101
1-66-0-L	CREW MESS	102
1-66-2-L	COMPANIONWAY	103

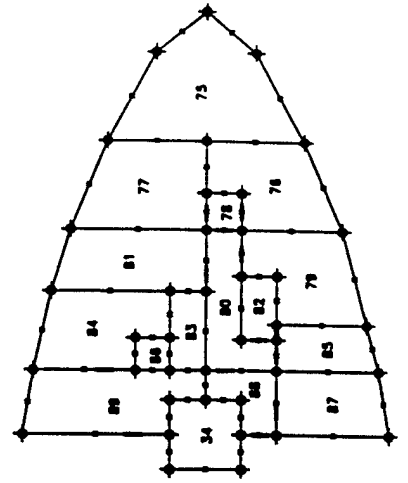

MAIN DECK

01 Level

Plan ID	Compartment Name	Drawing Number
1-57-3-Q	DUMBWAITER TRUNK	81
1-78-0-Q	MMR (UPTAKE)	107
01-27-0-C	BUOY DECK CONTROL BOOTH	133
01-57-0-Q	WARD ROOM PANTRY	134
01-57-2-L	CPO SR	135
01-57-4-L	CPO WR, WC, SH	136
01-60-1-L	WARDROOM MESSROOM & LOUNGE	137
01-60-0C-L	PASSAGE	138
01-83-2-L	CPO SR	139
01-60-0B-L	PASSAGE	140
01-86-2-L	PASSAGE	141
01-88-1-L	MEDICAL TREATMENT ROOM	142
01-88-0-Q	SHIP OFFICE	143
01-60-0A-L	PASSAGE	144
01-70-2-Q	C.G. LKR	145
01-71-2-L	CPO WR, WC, SH	146
01-74-1-L	MEDICAL TREATMENT WR, WC & SH	147
01-74-2-L	CPO SR	148
01-78-3-E	EMERGENCY GENERATOR ROOM	149
01-78-1-F	EMERGENCY GEN SERVICE TK	150
01-79-0A-L	PASSAGE	151
01-80-0-L	CREW SR	152
1-80-1-Q	VENT PLENUM	153
01-84-2-L	CREW WR, WC & SH	154
01-79-0B-L	PASSAGE	155
01-85-2-Q	FOUL WEATHER GEAR LKR	156
01-86-1-L	CREW SR	157
01-88-1-L	CREW WR, WC & SH	158
01-88-0-L	CREW SR	159
01-88-2-L	CREW SR	160
01-92-0-L	COMPANIONWAY	161

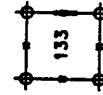
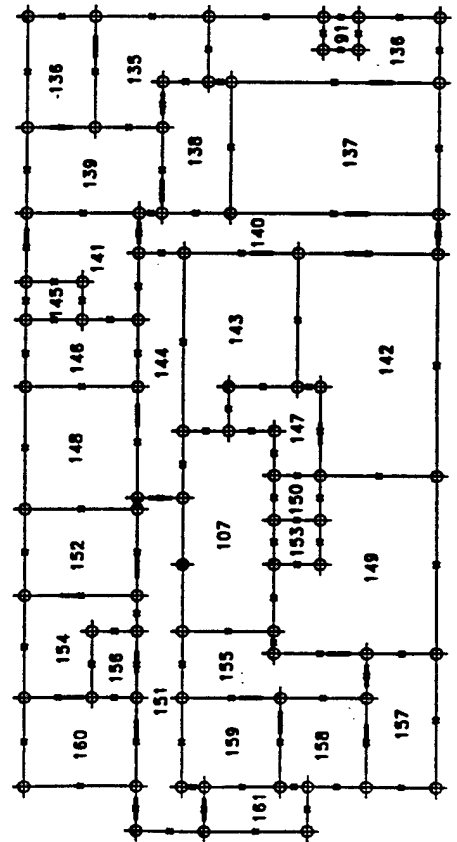

02 Level

Plan ID	Compartment Name	Drawing Number
1-76-0-Q	MMR (UPTAKE)	107
1-80-1-Q	VENT PLENUM	153
02-57-1-L	CO SR	162
02-57-0-L	CO CABIN	163
02-57-0C-L	PASSAGE	164
02-57-2-L	XO WR, WC, SH	165
02-57-4-L	XO SR	166
02-59-2-L	COMPANIONWAY	167
02-61-2-L	COMPANIONWAY	168
02-63-2-L	OFFICER SR	169
02-63-1-L	CO WR, WC, SH	170
02-66-1-L	OFFICER WR, WC, SH	171
02-66-0-C	RADIO ROOM	172
02-66-2-L	OFFICER WR, WC, SH	173
02-66-4-L	OFFICER WR, WC, SH	174
02-69-1-L	OFFICER SR	175
02-69-2-Q	CG LKR W/SINK	176
02-69-4-L	OFFICER SR	177
02-57-0A-L	PASSAGE	178
02-57-0B-L	PASSAGE	179
02-73-0-Q	FAN ROOM	180
02-75-1-Q	PFD & SURVIVAL SUIT LOCKER	181
02-75-2-Q	PFD & SURVIVAL SUIT LOCKER	182
02-85-0-Q	INCINERATOR ROOM	183

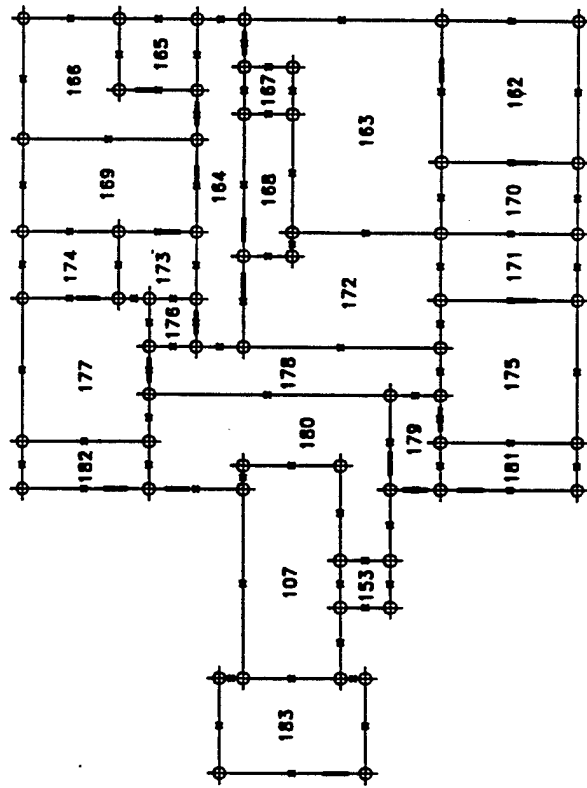

03 Level

Plan ID	Compartment Name	Drawing Number
03-56-0A-C	PILOT HOUSE	184
03-56-0B-C	PILOT HOUSE (CHART AREA)	185
03-56-0-L	DECK WR & WC	186
03-56-01-C	ELEX, IC & GYRO ROOM	187
03-76-0-Q	STACK	188

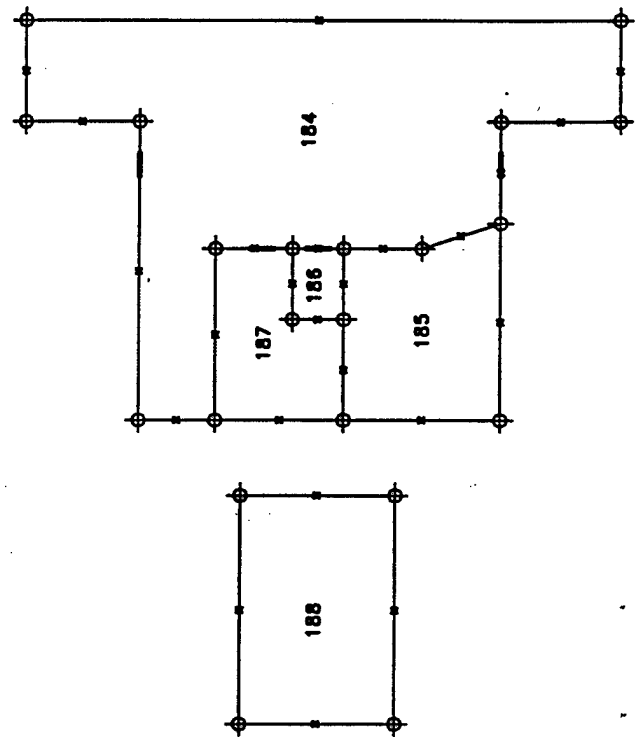

Appendix B Baseline Input Data

The various input data required to perform a fire safety analysis on the U. S. Coast Guard Seagoing Buoy Tender replacement (WLB (R)) class of cutter using SAFE is documented in Appendices B and D. In Appendix B the data used in the baseline data set (post-ship visit) are presented, in Appendix D the preliminary baseline data set (pre-ship visit) is presented.

The following is an index of the tables and attachments contained in this appendix.

B.1	Geometry	
	B.1.1 Compartment Height and Deck Area	B-2
	B.1.2 Ventilation Openings: Area and Average Height	B-6
B.2	Construction Materials	
	B.2.1 SAFE Provided Barrier Materials (attachment)	B-16
	B.2 Barrier Data	B-17
B.3	Fire Safety Objectives (MAL, FAL, and Frequency of EB)	
	B.3 Fire Safety Objectives	B-63
B.4	Fire Detection (% Time Monitored and Time to Detection)	
	B.4 Fire Detection	B-67
B.5	Automated and Manual Fire Protection Systems	
	B.5 Automated and Manual Fire Protection Systems	B-71
B.6	Probability of Flame Termination	
	B.6.1 Probability of Flame Termination (In Port)	B-75
	B.6.2 Probability of Flame Termination (At Sea)	B-80
B.7	Fuel Loads (Cellulosics, Plastics and Liquids)	
	B.7 Fuel Loads	B-84
B.8	Fire Growth Models, Heat Release Rates and FRI Times	
	B.8 Fire Growth Models, Rates and FRI Times	B-88

Table B.1.1 Compartment Height and Deck Area

Plan ID	Compartment Name	Height ft	Area sq ft
CUI=AA	(Cargo Hold)		
2-30-0-AA	CARGO HOLD	9	734.8
CUI=AG	(Gear Locker)		
3-6-0-Q	CHAIN LOCKER SUMP	8	70
2-6-1-Q	CHAIN LOCKER	9	35
2-6-2-Q	CHAIN LOCKER	9	35
1-77-1-A	CREW LOCKER	9.5	23.2
1-82-2-Q	C.G. LKR W/ SINK	9.5	16
01-70-2-Q	C.G. LKR	8.5	17
01-85-2-Q	FOUL WEATHER GEAR LKR	8.5	24
02-69-2-Q	CG LKR W/SINK	8.5	16
02-75-1-Q	PFD & SURVIVAL SUIT LOCKER	8.5	44
02-75-2-Q	PFD & SURVIVAL SUIT LOCKER	8.5	44
CUI=AR	(Refrigerated Storage)		
1-60-2-A	CHILL STRM	9.5	45.6
1-60-4-A	FREEZE STRM	9.5	45.6
CUI=AS	(Storeroom)		
3-57-0-A	SUPPLY DEPT. STOREROOM NO. 2	8	288
2-21-1-A	SUPPLY DEPT STOREROOM NO. 1	9	113.2
2-50-1-A	ENGINEER STOREROOM	9	182
2-57-2-A	SHIP STORE	9	81.6
1-0-0-A	BOATSWAIN STOREROOM NO. 1	9.5	202.8
1-6-1-A	BOATSWAIN STOREROOM NO. 2	9.5	121.3
1-18-4-A	ATON STRM	9.5	118
1-60-6A-A	DRY PROVISION STOREROOM	9.5	86.4
1-60-6B-A	DRY PROVISION STOREROOM	9.5	76.8
1-102-2-A	DECK GEAR STOREROOM	9.5	88.8
CUI=C	(Ship Control/Communications)		
2-89-1-C	ENGINEERING CONTROL CENTER	9	304.4
01-27-0-C	BUOY DECK CONTROL BOOTH	8.5	38.4
02-66-0-C	RADIO ROOM	8.5	145.6
03-56-0A-C	PILOT HOUSE	8.5	723.6
03-56-0B-C	PILOT HOUSE (CHART AREA)	8.5	169.2
03-66-01-C	ELEX, IC & GYRO ROOM	8.5	113.6
CUI=EM	(Main Propulsion - Mechanical)		
4-12-0-E	BOWTHRUSTER MCHRY ROOM	20	437
4-66-0-E	MAIN MACHINERY ROOM	20	1174.8
4-92-0-E	STERN THRUSTER MACHRY ROOM	20	274
1-102-0-E	STEERING GEAR ROOM	9.5	319.8
CUI=K	(Hazardous Material Storage)		
1-6-2-A	FLAM. LIQ. STOREROOM	9.5	138.9
CUI=L1	(Senior Officer's Cabin)		
02-57-0-L	CO CABIN	8.5	232
02-57-1-L	CO SR	8.5	132
02-57-4-L	XO SR	8.5	113.4
CUI=L2	(Officer/CPO Quarters)		
01-57-2-L	CPO SR	8.5	85.2
01-74-2-L	CPO SR	8.5	110
01-80-0-L	CREW SR	8.5	78
01-83-2-L	CPO SR	8.5	93.6
01-86-1-L	CREW SR	8.5	72
01-88-0-L	CREW SR	8.5	68.8
01-88-2-L	CREW SR	8.5	80
02-63-2-L	OFFICER SR	8.5	117

Table B.1.1 Compartment Height and Deck Area

Plan ID	Compartment Name	Height ft	Area sq ft
02-69-1-L	OFFICER SR	8.5	132
02-69-4-L	OFFICER SR	8.5	132
CUI=L5	(Crews Berthing)		
1-85-1-L	CREW SR	9.5	120
1-85-3-L	CREW SR	9.5	159.2
1-85-4-L	CREW SR	9.5	167.2
1-92-1-L	CREW SR	9.5	140.4
1-92-2-L	CREW SR	9.5	137.3
1-96-0-L	CREW SR	9.5	132
CUI=LL	(Wardroom/Mess/Lounge Areas)		
1-66-0-L	CREW MESS	9.5	555.2
1-77-2-L	CPO MESS & LOUNGE	9.5	150
1-77-3-L	CREW LOUNGE	9.5	150
01-60-1-L	WARDROOM MESSROOM & LOUNGE	8.5	216
CUI=LM	(Medical/Dental Spaces)		
01-68-1-L	MEDICAL TREATMENT ROOM	8.5	224
CUI=LP	(Passageway/Staircase/Vestibule)		
3-21-0-L	PASSAGE	8	71.6
2-21-0-L	PASSAGE	9	137.2
2-36-1-L	PASSAGE	9	33
2-39-1-L	PASSAGE	9	111.6
2-48-1-L	PASSAGE	9	92
2-53-1-L	VESTIBULE	9	48
2-57-0-L	PASSAGE	9	184
1-12-1A-L	PASSAGE	9.5	80
1-12-1B-L	PASSAGE	9.5	17.6
1-15-1-L	COMPANIONWAY	9.5	29.6
1-21-1-L	VESTIBULE	9.5	43.2
1-21-3-L	COMPANIONWAY	9.5	88.8
1-57-2-L	PASSAGE	9.5	106
1-59-2-L	COMPANIONWAY	9.5	40
1-66-2-L	COMPANIONWAY	9.5	52
1-82-0-L	PASSAGE	9.5	136
1-84-2-L	COMPANIONWAY	9.5	48
1-92-0-L	PASSAGE	9.5	184.8
01-60-0A-L	PASSAGE	8.5	88
01-60-0B-L	PASSAGE	8.5	93.6
01-60-0C-L	PASSAGE	8.5	72
01-66-2-L	PASSAGE	8.5	79
01-79-0A-L	PASSAGE	8.5	128
01-79-0B-L	PASSAGE	8.5	80
01-92-0-L	COMPANIONWAY	8.5	36
02-57-0A-L	PASSAGE	8.5	96
02-57-0B-L	PASSAGE	8.5	32
02-57-0C-L	PASSAGE	8.5	110.4
02-59-2-L	COMPANIONWAY	8.5	16
02-61-2-L	COMPANIONWAY	8.5	48
CUI=LW	(Sanitary Spaces)		
1-57-0-L	DECK WR & WC	9.5	40
1-57-4-Q	CHANGE ROOM	9.5	84
1-60-1-L	GALLEY WR & WC	9.5	32
1-82-1-L	CREW WR, WC & SH	9.5	56.4
1-82-3-L	CREW WR, WC & SH	9.5	57.6
1-82-4-L	CREW WR, WC & SH	9.5	66

Table B.1.1 Compartment Height and Deck Area

Plan ID	Compartment Name	Height ft	Area sq ft
1-96-1-L	CREW WR, WC & SH	9.5	60
1-97-4-L	CREW WR, WC & SH	9.5	70
1-98-1-L	CREW WR, WC & SH	9.5	62.4
01-57-4-L	CPO WR, WC, SH	8.5	61.2
01-71-2-L	CPO WR, WC, SH	8.5	60
01-74-1-L	MEDICAL TREATMENT WR, WC & SH	8.5	48
01-84-2-L	CREW WR, WC & SH	8.5	68
01-88-1-L	CREW WR, WC & SH	8.5	59.2
02-57-2-L	XO WR, WC, SH	8.5	39.6
02-63-1-L	CO WR, WC, SH	8.5	66
02-66-1-L	OFFICER WR, WC, SH	8.5	61.6
02-66-2-L	OFFICER WR, WC, SH	8.5	37
02-66-4-L	OFFICER WR, WC, SH	8.5	47
03-66-0-L	DECK WR & WC	8.5	22.4
CUI=QA	(Aux Machinery Spaces)		
4-82-0-E	AUXILIARY MACHINERY ROOM	29.5	756
2-21-2-Q	POTABLE WATER PUMP ROOM	9	193.6
2-48-2-E	SOR PUMP ROOM	9	270
2-49-0-E	SOR MACHINERY ROOM	9	208
2-57-4-E	WATER SUPPLY EQPT ROOM	9	186.6
1-18-1-Q	D.C. REPAIR LKR NO. 1	9.5	57.8
1-18-2-Q	AFFF STA.	9.5	36.8
1-74-2-Q	DC REPAIR LKR NO. 2	9.5	42
1-85-2-Q	AFFF STA.	9.5	40
CUI=QE	(Emergency Aux Generator Spaces)		
01-78-1-F	EMERGENCY GEN SERVICE TK	8.5	16
01-78-3-E	EMERGENCY GENERATOR ROOM	8.5	192
CUI=QF	(Fan Room)		
1-97-2-Q	FAN ROOM	9.5	60
02-73-0-Q	FAN ROOM	8.5	168
CUI=QG	(Galley/Pantry/Scullery)		
1-57-1-Q	GALLEY	9.5	349
1-66-1-Q	GALLEY ANNEX	9.5	84
1-66-3-Q	SCULLERY	9.5	90
01-57-0-Q	WARD ROOM PANTRY	8.5	111
02-85-0-Q	INCINERATOR ROOM	8.5	96
CUI=QL	(Laundry)		
1-105-2-Q	LAUNDRY	9.5	103
CUI=QO	(Office Spaces)		
1-71-2-Q	ENG LOG OFFICE & DC CENTRAL	9.5	108
01-68-0-Q	SHIP OFFICE	8.5	136
CUI=QS	(Shops)		
2-57-1-Q	MACHINE SHOP	9	232.2
2-59-1-Q	ELEC/ELEX WORKSHOP & STORERM	9	140
1-12-3-Q	BOATSWAIN SHOP	9.5	116.2
1-21-2-Q	ATON SHOP	9.5	132
CUI=TH	(Trunks/Hoists/Dumbwaiters)		
3-23-0-Q	CRANE PEDESTAL	26.5	64
1-19-2-T	ESC TRUNK	9.5	14.4
1-57-3-Q	DUMBWAITER TRUNK	18	9
1-80-1-E	VENT PLENUM	9.5	16.8
1-80-1-Q	VENT PLENUM	17	16
CUI=TU	(Stacks/Engine Uptakes)		
1-76-0-Q	MMR (UPTAKE)	26.5	144

Table B.1.1 Compartment Height and Deck Area

Plan ID	Compartment Name	Height ft	Area sq ft
03-76-0-Q	STACK	8.5	216
CUI=V	(Voids/Cofferdams)		
4-17-2-V	VOID	11	22.2
4-37-2-V	VOID	11	16
4-39-0-V	VOID	3	595.8
4-39-0A-V	VOID	8	108
4-39-0C-V	VOID	8	108
3-51-0-V	VOID	8	96
2-39-0-V	COFFERDAM	9	64
2-39-2-V	VOID	9	124.2
2-48-0-V	COFFERDAM	9	28
CUI=W	(Water Tank (empty))		
4-21-0A-W	SW BALLAST TANK	11	158.3
4-21-0B-W	SW BALLAST TANK	3	247.6
4-21-0C-W	SW BALLAST TANK	11	158.3
4-30-3-W	SW BALLAST TANK	11	115.2
4-30-4-W	SW BALLAST TANK	11	115.2
4-48-0A-W	SW BALLAST TANK	11	122.4
4-48-0B-W	SW BALLAST TANK	3	576
4-48-0C-W	SW BALLAST TANK	11	122.4
4-57-0A-W	SW BALLAST TANK	11	204.2
4-57-0B-W	SW BALLAST TANK	3	96
4-57-0C-W	SW BALLAST TANK	11	188.2
4-80-0-W	SEA BAY	3	26
4-0-0-W	SW BALLAST TANK	17	209.7
4-6-0A-W	SW BALLAST TANK	17	82.3
4-6-0B-W	SW BALLAST TANK	8	43.2
4-6-0C-W	SW BALLAST TANK	17	82.3
2-25-1-WW	POTABLE WATER (CARGO)	9	56
2-25-2-W	POTABLE WATER (SHIP)	9	56

Table B.1.2 Ventilation Openings: Area and Average Height

Plan ID	Compartment Name	# Vents	H/V	Area (In2)	Height (In.)	Total Area (In2)	Avg.Height (In.)
CUI=AA	(Cargo Hold)						
2-30-0-AA	CARGO HOLD					217	6
		1	V	81	9		
		1	V	100	10		
		1	V	36	1		
CUI=AG	(Gear Locker)						
3-6-0-Q	CHAIN LOCKER SUMP					246	10
2-6-1-Q	CHAIN LOCKER					246	10
2-6-2-Q	CHAIN LOCKER					246	10
1-77-1-A	CREW LOCKER					36	1
		1	V	36	1		
1-82-2-Q	C.G. LKR W/ SINK					261	7
		1	V	9	3		
		1	V	216	18		
		1	V	36	1		
01-70-2-Q	C.G. LKR					261	7
		1	V	9	3		
		1	V	216	18		
		1	V	36	1		
01-85-2-Q	FOUL WEATHER GEAR LKR					252	9
		1	V	216	18		
		1	V	36	1		
02-69-2-Q	CG LKR W/SINK					261	7
		1	V	9	3		
		1	V	216	18		
		1	V	36	1		
02-75-1-Q	PFD & SURVIVAL SUIT LOCKER					0	0
02-75-2-Q	PFD & SURVIVAL SUIT LOCKER					0	0
CUI=AR	(Refrigerated Storage)						
1-60-2-A	CHILL STRM					36	1
		1	V	36	1		
1-60-4-A	FREEZE STRM					36	1
		1	V	36	1		
CUI=AS	(Storeroom)						
3-57-0-A	SUPPLY DEPT. STOREROOM NO. 2					2160	96
		1	H	2160	96		
2-21-1-A	SUPPLY DEPT STOREROOM NO. 1					36	1
		1	V	36	1		
2-50-1-A	ENGINEER STOREROOM					85	4
		1	V	49	7		
		1	V	36	1		
2-57-2-A	SHIP STORE					61	54
		1	H	25	108		
		1	V	36	1		
1-0-0-A	BOATSWAIN STOREROOM NO. 1					16	114
		1	H	16	114		
1-6-1-A	BOATSWAIN STOREROOM NO. 2					52	57
		1	H	16	114		
		1	V	36	1		
1-18-4-A	ATON STRM					4	2
		1	V	4	2		
1-60-6A-A	DRY PROVISION STOREROOM					68	39
		1	H	16	114		
		1	V	16	4		

Table B.1.2 Ventilation Openings: Area and Average Height

Plan ID	Compartment Name	# Vents	H/V	Area (In2)	Height (In.)	Total Area (In2)	Avg.Height (In.)
		1	V	36	1		
1-60-6B-A	DRY PROVISION STOREROOM					144	1
		4	V	36	1		
1-102-2-A	DECK GEAR STOREROOM					140	24
		1	H	16	114		
		1	V	16	4		
		3	V	36	1		
CUI=C	(Ship Control/Communications)						
2-89-1-C	ENGINEERING CONTROL CENTER					315	65
		3	H	81	108		
		2	V	36	1		
01-27-0-C	BUOY DECK CONTROL BOOTH					36	1
		1	V	36	1		
02-66-0-C	RADIO ROOM					180	51
		1	H	144	102		
		1	V	36	1		
03-56-0A-C	PILOT HOUSE					4882	58
		2	V	702	27		
		2	V	703	37		
		5	H	400	102		
		2	V	36	1		
03-56-0B-C	PILOT HOUSE (CHART AREA)					1123	36
		1	H	400	102		
		1	V	600	20		
		1	V	42	14		
		1	V	81	9		
03-66-01-C	ELEX, IC & GYRO ROOM					159	8
		1	V	42	14		
		1	V	36	1		
		1	V	81	9		
CUI=EM	(Main Propulsion - Mechanical)						
4-12-0-E	BOWTHRUSTER MCHRY ROOM					612	240
		1	H	324	240		
		1	H	288	240		
4-66-0-E	MAIN MACHINERY ROOM					2046	13
		4	V	312	24		
		6	V	121	11		
		2	V	36	1		
4-92-0-E	STERN THRUSTER MACHRY ROOM					193	125
		1	H	72	240		
		1	V	121	11		
1-102-0-E	STEERING GEAR ROOM					110	4
		1	V	25	5		
		1	V	49	7		
		1	V	36	1		
CUI=K	(Hazardous Material Storage)						
1-6-2-A	FLAM. LIQ. STOREROOM					61	3
		1	V	25	5		
		1	V	36	1		
CUI=L1	(Senior Officer's Cabin)						
02-57-0-L	CO CABIN					432	28
		1	H	36	102		
		2	V	162	18		
		2	V	36	1		

Table B.1.2 Ventilation Openings: Area and Average Height

Plan ID	Compartment Name	# Vents	H/V	Area (In2)	Height (In.)	Total Area (In2)	Avg.Height (In.)
02-57-1-L	CO SR					486	28
		1	V	162	18		
		1	V	216	18		
		1	H	36	102		
		2	V	36	1		
02-57-4-L	XO SR					324	30
		1	V	216	18		
		1	H	36	102		
		2	V	36	1		
CUI=L2	(Officer/CPO Quarters)						
01-57-2-L	CPO SR					540	28
		1	H	36	102		
		2	V	216	18		
		2	V	36	1		
01-74-2-L	CPO SR					304	30
		1	H	16	102		
		1	V	216	18		
		2	V	36	1		
01-80-0-L	CREW SR					520	28
		1	H	16	102		
		2	V	216	18		
		2	V	36	1		
01-83-2-L	CPO SR					540	28
		2	V	216	18		
		1	H	36	102		
		2	V	36	1		
01-86-1-L	CREW SR					520	28
		1	H	16	102		
		2	V	216	18		
		2	V	36	1		
01-88-0-L	CREW SR					520	28
		1	H	16	102		
		2	V	216	18		
		2	V	36	1		
01-88-2-L	CREW SR					520	28
		1	H	16	102		
		2	V	216	18		
		2	V	36	1		
02-63-2-L	OFFICER SR					540	28
		1	H	36	102		
		2	V	216	18		
		2	V	36	1		
02-69-1-L	OFFICER SR					540	28
		1	H	36	102		
		2	V	216	18		
		2	V	36	1		
02-69-4-L	OFFICER SR					540	28
		1	H	36	102		
		2	V	216	18		
		2	V	36	1		
CUI=L5	(Crews Berthing)						
1-85-1-L	CREW SR					520	30
		1	H	16	114		
		2	V	216	18		

Table B.1.2 Ventilation Openings: Area and Average Height

Plan ID	Compartment Name	# Vents	H/V	Area (In2)	Height (In.)	Total Area (In2)	Avg.Height (In.)
		2	V	36	1		
1-85-3-L	CREW SR					520	30
		1	H	16	114		
		2	V	216	18		
		2	V	36	1		
1-85-4-L	CREW SR					520	30
		1	H	16	114		
		2	V	216	18		
		2	V	36	1		
1-92-1-L	CREW SR					520	30
		1	H	16	114		
		2	V	216	18		
		2	V	36	1		
1-92-2-L	CREW SR					520	30
		1	H	16	114		
		2	V	216	18		
		2	V	36	1		
1-96-0-L	CREW SR					520	30
		1	H	16	114		
		2	V	216	18		
		2	V	36	1		
CUI=LL	(Wardroom/Mess/Lounge Areas)						
1-66-0-L	CREW MESS					10338	43
		1	H	2592	114		
		7	V	36	1		
		3	V	2209	47		
		3	H	289	114		
1-77-2-L	CPO MESS & LOUNGE					132	76
		1	H	36	114		
		1	H	60	114		
		1	V	36	1		
1-77-3-L	CREW LOUNGE					288	44
		1	H	36	114		
		1	V	216	18		
		1	V	36	1		
01-60-1-L	WARDROOM MESSROOM & LOUNGE					324	30
		1	H	36	102		
		1	V	216	18		
		2	V	36	1		
CUI=LM	(Medical/Dental Spaces)						
01-68-1-L	MEDICAL TREATMENT ROOM					360	24
		1	H	36	102		
		1	V	216	18		
		3	V	36	1		
CUI=LP	(Passageway/Staircase/Vestibule)						
3-21-0-L	PASSAGE					104	2
		2	V	16	4		
		2	V	36	1		
2-21-0-L	PASSAGE					113	2
		1	V	16	4		
		1	V	25	5		
		2	V	36	1		
2-36-1-L	PASSAGE					56	2
		1	V	4	2		

Table B.1.2 Ventilation Openings: Area and Average Height

Plan ID	Compartment Name	# Vents	H/V	Area (In2)	Height (In.)	Total Area (In2)	Avg.Height (In.)
		1	V	16	4		
		1	V	36	1		
2-39-1-L	PASSAGE					16	4
		1	V	16	4		
2-48-1-L	PASSAGE					101	28
		1	H	4	108		
		1	V	25	5		
		2	V	36	1		
2-53-1-L	VESTIBULE					81	36
		1	H	9	108		
		2	V	36	1		
2-57-0-L	PASSAGE					2978	17
		1	H	2592	108		
		1	V	144	12		
		2	V	49	7		
		4	V	36	1		
1-12-1A-L	PASSAGE					186	2
		1	V	42	7		
		4	V	36	1		
1-12-1B-L	PASSAGE					0	0
1-15-1-L	COMPANIONWAY					36	1
		1	V	36	1		
1-21-1-L	VESTIBULE					44	1
		2	V	4	2		
		1	V	36	1		
1-21-3-L	COMPANIONWAY					36	1
		1	V	36	1		
1-57-2-L	PASSAGE					280	2
		1	V	60	6		
		1	V	40	5		
		5	V	36	1		
1-59-2-L	COMPANIONWAY					2628	57
		1	H	2592	114		
		1	V	36	1		
1-66-2-L	COMPANIONWAY					2196	57
		1	H	2160	114		
		1	V	36	1		
1-82-0-L	PASSAGE					1092	8
		4	V	216	18		
		1	V	48	8		
		5	V	36	1		
1-84-2-L	COMPANIONWAY					2628	57
		1	V	36	1		
		1	H	2592	114		
1-92-0-L	PASSAGE					3516	16
		1	H	2592	114		
		2	V	48	4		
		3	V	216	18		
		5	V	36	1		
01-60-0A-L	PASSAGE					696	30
		1	H	192	102		
		1	V	432	18		
		2	V	36	1		
01-60-0B-L	PASSAGE					616	5

Table B.1.2 Ventilation Openings: Area and Average Height

Plan ID	Compartment Name	# Vents	H/V	Area (In2)	Height (In.)	Total Area (In2)	Avg.Height (In.)
		2	V	216	18		
		1	V	4	2		
		5	V	36	1		
01-60-0C-L	PASSAGE					3096	28
		1	H	2592	102		
		2	V	216	18		
		2	V	36	1		
01-66-2-L	PASSAGE					2880	30
		1	H	2592	102		
		1	V	216	18		
		2	V	36	1		
01-79-0A-L	PASSAGE					1051	8
		1	V	198	22		
		1	V	25	5		
		3	V	216	18		
		5	V	36	1		
01-79-0B-L	PASSAGE					756	7
		2	V	324	18		
		3	V	36	1		
01-92-0-L	COMPANIONWAY					2628	51
		1	H	2592	102		
		1	V	36	1		
02-57-0A-L	PASSAGE					358	8
		1	V	25	5		
		1	V	216	18		
		1	V	81	9		
		1	V	36	1		
02-57-0B-L	PASSAGE					252	9
		1	V	216	18		
		1	V	36	1		
02-57-0C-L	PASSAGE					540	5
		2	V	162	18		
		6	V	36	1		
02-59-2-L	COMPANIONWAY					2628	51
		1	V	36	1		
		1	H	2592	102		
02-61-2-L	COMPANIONWAY					2628	51
		1	H	2592	102		
		1	V	36	1		
CUI=LW	(Sanitary Spaces)						
1-57-0-L	DECK WR & WC					52	2
		1	V	16	4		
		1	V	36	1		
1-57-4-Q	CHANGE ROOM					76	3
		1	V	40	5		
		1	V	36	1		
1-60-1-L	GALLEY WR & WC					152	5
		1	V	16	4		
		1	V	100	10		
		1	V	36	1		
1-82-1-L	CREW WR, WC & SH					484	10
		1	V	16	4		
		2	V	216	18		
		1	V	36	1		

Table B.1.2 Ventilation Openings: Area and Average Height

Plan ID	Compartment Name	# Vents	H/V	Area (In2)	Height (In.)	Total Area (In2)	Avg.Height (In.)
1-82-3-L	CREW WR, WC & SH					484	10
		1	V	16	4		
		2	V	216	18		
1-82-4-L	CREW WR, WC & SH	1	V	36	1	484	10
		1	V	16	4		
		2	V	216	18		
1-96-1-L	CREW WR, WC & SH	1	V	36	1	484	10
		1	V	16	4		
		2	V	216	18		
1-97-4-L	CREW WR, WC & SH	1	V	36	1	484	10
		1	V	16	4		
		2	V	216	18		
1-98-1-L	CREW WR, WC & SH	1	V	36	1	484	10
		1	V	16	4		
		2	V	216	18		
01-57-4-L	CPO WR, WC, SH	1	V	36	1	513	8
		2	V	216	18		
		1	V	9	3		
		2	V	36	1		
01-71-2-L	CPO WR, WC, SH	1	V	36	1	268	7
		1	V	16	4		
		1	V	216	18		
		1	V	36	1		
01-74-1-L	MEDICAL TREATMENT WR, WC & SH	1	H	25	102	277	40
		1	V	216	18		
		1	V	36	1		
01-84-2-L	CREW WR, WC & SH	2	V	36	1	513	8
		1	V	9	3		
		2	V	36	1		
01-88-1-L	CREW WR, WC & SH	2	V	36	1	520	8
		1	V	16	4		
		2	V	216	18		
02-57-2-L	XO WR, WC, SH	1	V	16	4	232	11
		1	V	216	18		
02-63-1-L	CO WR, WC, SH	1	H	36	102	288	40
		1	V	216	18		
		1	V	36	1		
02-66-1-L	OFFICER WR, WC, SH	1	V	36	1	268	7
		1	V	16	4		
		1	V	216	18		
02-66-2-L	OFFICER WR, WC, SH	1	V	16	4	268	7
		1	V	216	18		
		1	V	16	4		

Table B.1.2 Ventilation Openings: Area and Average Height

Plan ID	Compartment Name	# Vents	H/V	Area (In2)	Height (In.)	Total Area (In2)	Avg.Height (In.)
		1	V	36	1		
02-66-4-L	OFFICER WR, WC, SH					268	7
		1	V	216	18		
		1	V	16	4		
		1	V	36	1		
03-66-0-L	DECK WR & WC					52	2
		1	V	16	4		
		1	V	36	1		
CUI=QA	(Aux Machinery Spaces)						
4-82-0-E	AUXILIARY MACHINERY ROOM					1108	244
		4	H	121	354		
		2	V	312	24		
2-21-2-Q	POTABLE WATER PUMP ROOM					252	40
		1	H	96	108		
		1	V	120	12		
		1	V	36	1		
2-48-2-E	SOR PUMP ROOM					61	108
2-49-0-E	SOR MACHINERY ROOM					181	5
		1	V	25	5		
		1	V	120	10		
		1	V	36	1		
2-57-4-E	WATER SUPPLY EQPT ROOM					142	39
		1	H	25	108		
		1	V	81	9		
		1	V	36	1		
1-18-1-Q	D.C. REPAIR LKR NO. 1					0	0
1-18-2-Q	AFFF STA.					0	0
1-74-2-Q	DC REPAIR LKR NO. 2					36	1
		1	V	36	1		
1-85-2-Q	AFFF STA.					0	0
CUI=QE	(Emergency Aux Generator Spaces)						
01-78-1-F	EMERGENCY GEN SERVICE TK					0	0
01-78-3-E	EMERGENCY GENERATOR ROOM					2652	19
		1	V	24	6		
		2	V	1296	36		
		1	V	36	1		
CUI=QF	(Fan Room)						
1-97-2-Q	FAN ROOM					36	1
		1	V	36	1		
02-73-0-Q	FAN ROOM					36	1
		1	V	36	1		
CUI=QG	(Galley/Pantry/Scullery)						
1-57-1-Q	GALLEY					1421	68
		1	H	169	114		
		1	H	220	114		
		1	H	960	114		
		2	V	36	1		
1-66-1-Q	GALLEY ANNEX					6390	49
		1	H	40	114		
		2	V	3157	41		
		1	V	36	1		
1-66-3-Q	SCULLERY					545	34
		1	H	32	114		
		1	V	441	21		

Table B.1.2 Ventilation Openings: Area and Average Height

Plan ID	Compartment Name	# Vents	H/V	Area (ln2)	Height (ln.)	Total Area (ln2)	Avg.Height (ln.)
		2	V	36	1		
01-57-0-Q	WARD ROOM PANTRY					308	76
		1	H	72	102		
		2	H	100	102		
		1	V	36	1		
02-85-0-Q	INCINERATOR ROOM					130	8
		1	V	49	7		
		1	V	81	9		
CUI=QL	(Laundry)						
1-105-2-Q	LAUNDRY					97	4
		1	V	25	5		
		1	V	36	6		
		1	V	36	1		
CUI=QO	(Office Spaces)						
1-71-2-Q	ENG LOG OFFICE & DC CENTRAL					152	76
		1	H	16	114		
		1	H	100	114		
		1	V	36	1		
01-68-0-Q	SHIP OFFICE					368	55
		1	H	64	102		
		1	V	216	18		
		1	V	36	1		
		1	H	52	102		
CUI=QS	(Shops)						
2-57-1-Q	MACHINE SHOP					133	4
		1	V	48	6		
		1	V	49	7		
		1	V	36	1		
2-59-1-Q	ELEC/ELEX WORKSHOP & STORERM					109	4
		1	V	48	6		
		1	V	25	5		
		1	V	36	1		
1-12-3-Q	BOATSWAIN SHOP					85	3
		1	V	25	5		
		1	V	24	4		
		1	V	36	1		
1-21-2-Q	ATON SHOP					74	6
		1	V	25	5		
		1	V	49	7		
CUI=TH	(Trunks/Hoists/Dumbwaiters)						
3-23-0-Q	CRANE PEDESTAL					10	1
1-19-2-T	ESC TRUNK					10	1
1-57-3-Q	DUMBWAITER TRUNK					10	1
1-80-1-E	VENT PLENUM					10	1
1-80-1-Q	VENT PLENUM					10	1
CUI=TU	(Stacks/Engine Uptakes)						
1-76-0-Q	MMR (UPTAKE)					1296	48
03-76-0-Q	STACK					1296	48
CUI=V	(Voids/Cofferdams)						
4-17-2-V	VOID					0	0
4-37-2-V	VOID					0	0
4-39-0-V	VOID					0	0
4-39-0A-V	VOID					0	0
4-39-0C-V	VOID					0	0

Table B.1.2 Ventilation Openings: Area and Average Height

Plan ID	Compartment Name	# Vents	H/V	Area (ln2)	Height (ln.)	Total Area (ln2)	Avg.Height (ln.)
3-51-0-V	VOID					0	0
2-39-0-V	COFFERDAM					0	0
2-39-2-V	VOID					0	0
2-48-0-V	COFFERDAM					0	0
CUI=W	(Water Tank (empty))						
4-21-0A-W	SW BALLAST TANK					0	0
4-21-0B-W	SW BALLAST TANK					0	0
4-21-0C-W	SW BALLAST TANK					0	0
4-30-3-W	SW BALLAST TANK					0	0
4-30-4-W	SW BALLAST TANK					0	0
4-48-0A-W	SW BALLAST TANK					0	0
4-48-0B-W	SW BALLAST TANK					0	0
4-48-0C-W	SW BALLAST TANK					0	0
4-57-0A-W	SW BALLAST TANK					0	0
4-57-0B-W	SW BALLAST TANK					0	0
4-57-0C-W	SW BALLAST TANK					0	0
4-80-0-W	SEA BAY					0	0
4-0-0-W	SW BALLAST TANK					0	0
4-6-0A-W	SW BALLAST TANK					0	0
4-6-0B-W	SW BALLAST TANK					0	0
4-6-0C-W	SW BALLAST TANK					0	0
2-25-1-WW	POTABLE WATER (CARGO)					0	0
2-25-2-W	POTABLE WATER (SHIP)					0	0

Attachment B.2.1

SAFE PROVIDED BARRIER MATERIALS (English Units)

ID	Description	Structural or Non	Thickness inches	Density lb/ft ³	Spec Ht BTU/lb.F°	Therm.Cond BTU/min.ft.F°	Ht Rel %	Tbar			Dbar			
								X-1 kBTU/min.ft ²	X-2 kBTU/min.ft ²	X-3 kBTU/min.ft ²	X-1 kBTU/min.ft ²	X-2 kBTU/min.ft ²	X-3 kBTU/min.ft ²	
000	Zero-strength (includes screening and grating)	N	0.000	0	0.000	96.29	100	0	0	0	0	0	0	0
A21	1/4" Aluminum with thermal insulation	S	2.000	162	0.048	0.05	5	3	6	10	3	6	10	10
A2U	1/4" Aluminum	S	0.250	166	0.230	1.22	15	0	2	4	4	4	6	10
CSU	5/8" Celotex (overhead: below crawl space layer)	N	0.625	1	0.167	0.00	25	1	3	4	1	3	4	4
F2U	1/4" Fiberglass Toilet/Shower Enclosure	N	0.250	86	0.229	0.00	35	2	5	7	25	35	40	40
NPI	Nomex honeycomb core - plastic laminate & insulation	N	2.000	3	0.289	0.00	30	2	8	10	9	18	22	22
NPU	Nomex honeycomb core - plastic laminate facing	N	0.625	3	0.289	0.00	30	2	6	14	3	12	20	20
NSU	Nomex honeycomb core - stainless steel facing	N	0.625	3	0.289	0.00	25	8	20	30	55	80	105	105
P7P	7/8" Plywood - plastic laminate facing, both sides	N	0.875	34	0.290	0.00	15	6	12	21	10	20	27	27
S21	1/4" Steel with thermal insulation	S	2.000	487	0.024	0.01	5	5	15	18	75	100	120	120
S2U	1/4" Steel	S	0.250	490	0.119	0.44	5	1	4	10	60	80	100	100
S31	3/8" Steel with thermal insulation	S	2.000	487	0.024	0.01	5	6	18	20	80	110	130	130
S3U	3/8" Steel	S	0.375	490	0.119	0.44	5	1	4	10	65	85	105	105
S41	1/2" Steel with thermal insulation	S	2.000	487	0.024	0.01	5	6	18	20	80	110	130	130
S4U	1/2" Steel	S	0.500	490	0.119	0.44	5	2	5	12	70	90	110	110
S5U	5/8" Steel	S	0.625	490	0.119	0.44	5	2	5	12	75	95	115	115

Table B.2 Barrier Data

Barrier Materials			Plan ID	Compartment Name Adjacent Compartment	Area sq ft	Therm adj	Durab adj	Doors / Hatches	DC Rating
<1>	<2>	<3>							
			4-12-0-E	BOWTHRUSTER MCHRY ROOM	(CUI = EM)				
S3U	S3U	S3U	4-17-1-F	FUEL TANK	19.8	0	0		
S3I	S3U	S3U	4-17-1-F	FUEL TANK	105.6	0	0		
S3U	S3U	S3U	4-17-2-V	VOID	9	0	0		
S3I	S3U	S3U	4-17-2-V	VOID	24	0	0		
S3U	S3U	S3U	4-17-4-F	FUEL TANK	10.8	0	0		
S3I	S3U	S3U	4-17-4-F	FUEL TANK	81.6	0	0		
S3I	S3U	S3U	4-6-0A-W	SW BALLAST TANK	44.8	0	0		
S3I	S3U	S3U	4-6-0A-W	SW BALLAST TANK	59.4	0	0		
S3I	S3U	S3U	4-6-0B-W	SW BALLAST TANK	96	0	0		
S3I	S3U	S3U	4-6-0C-W	SW BALLAST TANK	44.8	0	0		
S3I	S3U	S3U	4-6-0C-W	SW BALLAST TANK	59.4	0	0		
S3I	S3U	S3U	2-10-0-F	HYD OIL STG TANK	108	0	0		
S3U		S3U	2-13-1-F	HPU RESERVOIR	39.6	0	0		
S3U		S3U	2-13-1-F	HPU RESERVOIR	80.4	0	0		
S3U		S3U	2-13-1-F	HPU RESERVOIR	18	0	0		
S3U		S3U	2-13-1-F	HPU RESERVOIR	77.4	0	0		
S3U		S3U	2-13-2-F	HPU RESERVOIR	39.6	0	0		
S3U		S3U	2-13-2-F	HPU RESERVOIR	77.4	0	0		
S3U		S3U	2-13-2-F	HPU RESERVOIR	18	0	0		
S3U		S3U	2-13-2-F	HPU RESERVOIR	80.4	0	0		
S3U	S3U	S3U	2-21-0-L	PASSAGE	162	0	0		
S3U	S3U	S3U	2-21-1-A	SUPPLY DEPT STOREROO	48.6	0	0		
S3U	S3U	S3U	2-21-2-Q	POTABLE WATER PUMP R	102.6	0	0		
S2I	S5U		(none)	(weather bulkhead)	27.4	0	0		
S2I	S5U		(none)	(weather bulkhead)	30	0	0		
S2I	S5U		(none)	(weather bulkhead)	27.4	0	0		
S2U	S5U		(none)	(weather bulkhead)	73.1	0	0		
S2I	S5U		(none)	(weather bulkhead)	73.1	0	0		
S2I	S5U		(none)	(weather bulkhead)	153.8	0	0		
S2I	S5U		(none)	(weather bulkhead)	153.8	0	0		
S4U			4-17-1-F	FUEL TANK	104.1	0	0		
S4U			4-17-2-V	VOID	22.2	0	0		
S4U			4-17-4-F	FUEL TANK	81.9	0	0		
S4U			2-13-1-F	HPU RESERVOIR	25.8	0	0		
S4U			2-13-2-F	HPU RESERVOIR	25.8	0	0		
S4U			1-12-1A-L	PASSAGE	80	0	0		
S4U			1-12-2-M	ARMORY	79.8	0	0		
S4U			1-12-3-Q	BOATSWAIN SHOP	67.2	0	0		
S4U			1-15-1-L	COMPANIONWAY	24.8	0	0	HL	X
								HS	Z
S4U			1-18-1-Q	D.C. REPAIR LKR NO.	46.5	0	0		
S4U			1-18-2-Q	AFFF STA.	36.8	0	0		
S4U			1-18-4-A	ATON STRM	87.5	0	0		
S4U			1-19-2-T	ESC TRUNK	14.4	0	0		
			4-17-2-V	VOID	(CUI = V)				
S3U	S3U	S3U	4-12-0-E	BOWTHRUSTER MCHRY RO	9	0	0		
S3U	S3U	S3I	4-12-0-E	BOWTHRUSTER MCHRY RO	24	0	0		
S3U		S3U	4-17-1-F	FUEL TANK	22.2	0	0		
S3U		S3U	4-17-1-F	FUEL TANK	59.2	0	0		
S3U		S3U	4-17-4-F	FUEL TANK	22.2	0	0		
S3U		S3U	4-17-4-F	FUEL TANK	59.2	0	0		
S3U	S3U	S3U	4-21-0B-W	SW BALLAST TANK	9	0	0		
S3U	S3U	S3I	3-21-0-L	PASSAGE	24	0	0		

Table B.2 Barrier Data

Barrier Materials			Plan ID	Compartment Name Adjacent Compartment	Area sq ft	Therm adj	Durab adj	Doors / Hatches	DC Rating
<1>	<2>	<3>							
S4U			4-12-0-E	BOWTHRUSTER MCHRY RO	22.2	0	0		
			4-21-0A-W	SW BALLAST TANK	(CUI = W)				
S3U	S3U	S3U	4-17-4-F	FUEL TANK	16.2	0	0		
S3U	S3U	S3U	4-17-4-F	FUEL TANK	75.2	0	0		
000		000	4-21-0B-W	SW BALLAST TANK	27	0	0		
000		000	4-21-0B-W	SW BALLAST TANK	23	0	0		
S3U	S3U	S3U	4-30-2-F	FUEL TANK	12	0	0		
S3U	S3U	S3U	4-30-2-F	FUEL TANK	32	0	0		
S3U	S3U	S3U	4-30-4-W	SW BALLAST TANK	10.8	0	0		
S3U	S3U	S3U	4-30-4-W	SW BALLAST TANK	56	0	0		
S3U		S3I	3-21-0-L	PASSAGE	61.3	0	0		
S3U		S3I	3-25-2-M	MAGAZINE NO. 2	72	0	0		
S2U	S5U		(none)	(weather bulkhead)	50.8	0	0		
S2U	S5U		(none)	(weather bulkhead)	134.3	0	0		
S4U			2-21-2-Q	POTABLE WATER PUMP R	158.3	0	0		
			4-21-0B-W	SW BALLAST TANK	(CUI = W)				
S3U	S3U	S3U	4-17-1-F	FUEL TANK	18	0	0		
S3U	S3U	S3U	4-17-2-V	VOID	9	0	0		
S3U	S3U	S3U	4-17-4-F	FUEL TANK	9	0	0		
000		000	4-21-0A-W	SW BALLAST TANK	27	0	0		
000		000	4-21-0A-W	SW BALLAST TANK	23	0	0		
000		000	4-21-0C-W	SW BALLAST TANK	27	0	0		
000		000	4-21-0C-W	SW BALLAST TANK	23	0	0		
S3U	S3U	S3U	4-30-0-F	FUEL TANK	48	0	0		
S4U			3-21-0-L	PASSAGE	71.6	0	0		
S4I			3-23-0-Q	CRANE PEDESTAL	64	0	0		
S4U			3-25-1-M	MAGAZINE NO. 1	56	0	0		
S4U			3-25-2-M	MAGAZINE NO. 2	56	0	0		
			4-21-0C-W	SW BALLAST TANK	(CUI = W)				
S3U	S3U	S3U	4-17-1-F	FUEL TANK	16.2	0	0		
S3U	S3U	S3U	4-17-1-F	FUEL TANK	75.2	0	0		
000		000	4-21-0B-W	SW BALLAST TANK	27	0	0		
000		000	4-21-0B-W	SW BALLAST TANK	23	0	0		
S3U	S3U	S3U	4-30-1-F	FUEL TANK	12	0	0		
S3U	S3U	S3U	4-30-1-F	FUEL TANK	32	0	0		
S3U	S3U	S3U	4-30-3-W	SW BALLAST TANK	10.8	0	0		
S3U	S3U	S3U	4-30-3-W	SW BALLAST TANK	56	0	0		
S3U		S3I	3-21-0-L	PASSAGE	61.3	0	0		
S3U		S3I	3-25-1-M	MAGAZINE NO. 1	72	0	0		
S2U	S5U		(none)	(weather bulkhead)	50.8	0	0		
S2U	S5U		(none)	(weather bulkhead)	134.3	0	0		
S4U			2-21-0-L	PASSAGE	73	0	0		
S4U			2-21-1-A	SUPPLY DEPT STOREROO	85.3	0	0		
			4-30-3-W	SW BALLAST TANK	(CUI = W)				
S3U	S3U	S3U	4-21-0C-W	SW BALLAST TANK	10.8	0	0		
S3U	S3U	S3U	4-21-0C-W	SW BALLAST TANK	56	0	0		
S3U		S3U	4-30-1-F	FUEL TANK	55	0	0		
S3U		S3U	4-30-1-F	FUEL TANK	146.9	0	0		
S3U	S3U	S3U	4-39-0C-V	VOID	43.2	0	0		
S3U	S5U		(none)	(weather bulkhead)	9.6	0	0		
S2U	S5U		(none)	(weather bulkhead)	54.7	0	0		
S2U	S5U		(none)	(weather bulkhead)	145.3	0	0		
S4U			2-30-0-AA	CARGO HOLD	85.2	0	0		
S4U			2-36-1-L	PASSAGE	30	0	0		

Table B.2 Barrier Data

Barrier Materials			Plan ID	Compartment Name Adjacent Compartment	Area sq ft	Therm adj	Durab adj	Doors / Hatches	DC Rating
<1>	<2>	<3>							
			4-30-4-W	SW BALLAST TANK	(CUI = W)				
S3U	S3U	S3U	4-21-0A-W	SW BALLAST TANK	10.8	0	0		
S3U	S3U	S3U	4-21-0A-W	SW BALLAST TANK	56	0	0		
S3U		S3U	4-30-2-F	FUEL TANK	55.1	0	0		
S3U		S3U	4-30-2-F	FUEL TANK	146.9	0	0		
S3U	S3U	S3U	4-39-0A-V	VOID	43.2	0	0		
S3U	S5U		(none)	(weather bulkhead)	9	0	0		
S2U	S5U		(none)	(weather bulkhead)	54.7	0	0		
S3U	S5U		(none)	(weather bulkhead)	145.3	0	0		
S4U			2-30-0-AA	CARGO HOLD	115.2	0	0		
			4-37-2-V	VOID	(CUI = V)				
S3U		S3U	4-30-0-F	FUEL TANK	12	0	0		
S3U		S3U	4-30-0-F	FUEL TANK	12	0	0		
S3U		S3U	4-30-0-F	FUEL TANK	12	0	0		
S3U		S3U	4-30-0-F	FUEL TANK	32	0	0		
S3U		S3U	4-30-0-F	FUEL TANK	32	0	0		
S3U		S3U	4-30-0-F	FUEL TANK	32	0	0		
S3U	S3U	S3U	4-39-0-V	VOID	12	0	0		
S3U	S3U	S3U	3-39-0-FF	SOR TANK	32	0	0		
S4U			2-30-0-AA	CARGO HOLD	16	0	0		
			4-39-0-V	VOID	(CUI = V)				
S3U	S3U	S3U	4-30-0-F	FUEL TANK	24	0	0		
S3U	S3U	S3U	4-30-0-F	FUEL TANK	12	0	0		
S3U	S3U	S3U	4-30-1-F	FUEL TANK	22.2	0	0		
S3U	S3U	S3U	4-30-2-F	FUEL TANK	22.8	0	0		
S3U	S3U	S3U	4-37-2-V	VOID	12	0	0		
S3U	S3U	S3U	4-48-0A-W	SW BALLAST TANK	4.8	0	0		
S2I	S3U	S3U	4-48-0B-W	SW BALLAST TANK	96	0	0		
S3U	S3U	S3U	4-48-0C-W	SW BALLAST TANK	4.8	0	0		
S2U	S5U		(none)	(weather bulkhead)	54.4	0	0		
S2U	S5U		(none)	(weather bulkhead)	54.3	0	0		
S4U			3-39-0-FF	SOR TANK	573.8	0	0		
S4U			4-39-0A-V	VOID	11.5	0	0		
S4U			4-39-0C-V	VOID	10.5	0	0		
			4-48-0A-W	SW BALLAST TANK	(CUI = W)				
S3U	S3U	S3U	4-39-0-V	VOID	4.8	0	0		
000		000	4-48-0B-W	SW BALLAST TANK	54	0	0		
S3U	S3U	S3U	4-57-0A-W	SW BALLAST TANK	7.2	0	0		
S3U	S3U	S3U	4-57-0A-W	SW BALLAST TANK	56	0	0		
S3U	S3U	S3U	4-39-0A-V	VOID	52.8	0	0		
S3U		S3U	3-48-2-F	FUEL TANK	144	0	0		
S2U	S5U		(none)	(weather bulkhead)	54	0	0		
S2U	S5U		(none)	(weather bulkhead)	144	0	0		
S3U	S5U		(none)	(weather bulkhead)	7.2	0	0		
S3U	S5U		(none)	(weather bulkhead)	7.8	0	0		
S4U			2-48-2-E	SOR PUMP ROOM	122.4	0	0		
			4-48-0B-W	SW BALLAST TANK	(CUI = W)				
S3U	S3U	S2I	4-39-0-V	VOID	96	0	0		
000		000	4-48-0A-W	SW BALLAST TANK	54	0	0		
000		000	4-48-0C-W	SW BALLAST TANK	54	0	0		
S3U	S3U	S3U	4-57-0A-W	SW BALLAST TANK	24	0	0		
S3U	S3U	S3U	4-57-0B-W	SW BALLAST TANK	48	0	0		
S3U	S3U	S3U	4-57-0C-W	SW BALLAST TANK	24	0	0		
S4U			3-48-0-FF	CARGO FUEL TANK	96	0	0		

Table B.2 Barrier Data

Barrier Materials			Plan ID	Compartment Name Adjacent Compartment	Area sq ft	Therm adj	Durab adj	Doors / Hatches	DC Rating
<1>	<2>	<3>							
S4U			3-48-1-F	FUEL TANK	144	0	0		
S4U			3-48-2-F	FUEL TANK	144	0	0		
S4U			3-51-0-V	VOID	96	0	0		
S4U			3-54-0-F	FUEL OIL OVFL TANK	96	0	0		
			4-48-0C-W	SW BALLAST TANK	(CUI = W)				
S3U	S3U	S3U	4-39-0-V	VOID	4.8	0	0		
000		000	4-48-0B-W	SW BALLAST TANK	54	0	0		
S3U	S3U	S3U	4-57-0C-W	SW BALLAST TANK	7.2	0	0		
S3U	S3U	S3U	4-57-0C-W	SW BALLAST TANK	56	0	0		
S3U	S3U	S3U	4-39-0C-V	VOID	52.8	0	0		
S3U		S3U	3-48-1-F	FUEL TANK	144	0	0		
S2U	S5U		(none)	(weather bulkhead)	54	0	0		
S3U	S5U		(none)	(weather bulkhead)	144	0	0		
S3U	S5U		(none)	(weather bulkhead)	7.2	0	0		
S3U	S5U		(none)	(weather bulkhead)	7.8	0	0		
S4U			2-48-1-L	PASSAGE	26.6	0	0		
S4U			2-50-1-A	ENGINEER STOREROOM	95.8	0	0		
			4-57-0A-W	SW BALLAST TANK	(CUI = W)				
S3U	S3U	S3U	4-48-0A-W	SW BALLAST TANK	7.2	0	0		
S3U	S3U	S3U	4-48-0A-W	SW BALLAST TANK	56	0	0		
S3U	S3U	S3U	4-48-0B-W	SW BALLAST TANK	24	0	0		
S3U		S3U	4-57-0B-W	SW BALLAST TANK	18	0	0		
S3U		S3U	4-60-2-F	OILY WATER TANK	36	0	0		
S3U	S3U	S3I	4-66-0-E	MAIN MACHINERY ROOM	28.8	0	0		
S3U	S3U	S3I	4-66-0-E	MAIN MACHINERY ROOM	33.6	0	0		
S3U	S3U	S3U	3-48-2-F	FUEL TANK	64	0	0		
S3U		S3I	3-57-0-A	SUPPLY DEPT. STORERO	80	0	0		
S3U		S3U	3-62-2-F	FUEL SERVICE TANK	64	0	0		
S3U		S3U	3-62-2-F	FUEL SERVICE TANK	64	0	0		
S2U	S5U		(none)	(weather bulkhead)	54.1	0	0		
S2U	S5U		(none)	(weather bulkhead)	144	0	0		
S3I	S5U		(none)	(weather bulkhead)	20.8	0	0		
S4U			3-62-2-F	FUEL SERVICE TANK	64	0	0		
S4U			2-57-2-A	SHIP STORE	80	0	0		
S4U			2-57-4-E	WATER SUPPLY EQPT RO	124.2	0	0		
			4-57-0B-W	SW BALLAST TANK	(CUI = W)				
S3U	S3U	S3U	4-48-0B-W	SW BALLAST TANK	48	0	0		
S3U		S3U	4-57-0A-W	SW BALLAST TANK	18	0	0		
S3U		S3U	4-57-0C-W	SW BALLAST TANK	18	0	0		
S3U		S3U	4-60-1-F	LO DRAIN TANK	24	0	0		
S3U		S3U	4-60-2-F	OILY WATER TANK	24	0	0		
S4U			3-57-0-A	SUPPLY DEPT. STORERO	96	0	0		
			4-57-0C-W	SW BALLAST TANK	(CUI = W)				
S3U	S3U	S3U	4-48-0B-W	SW BALLAST TANK	24	0	0		
S3U	S3U	S3U	4-48-0C-W	SW BALLAST TANK	7.2	0	0		
S3U	S3U	S3U	4-48-0C-W	SW BALLAST TANK	56	0	0		
S3U		S3U	4-57-0B-W	SW BALLAST TANK	18	0	0		
S3U		S3U	4-60-1-F	LO DRAIN TANK	36	0	0		
S3U	S3U	S3I	4-66-0-E	MAIN MACHINERY ROOM	28.8	0	0		
S3U	S3U	S3I	4-66-0-E	MAIN MACHINERY ROOM	33.6	0	0		
S3U	S3U	S3U	3-48-1-F	FUEL TANK	64	0	0		
S3U		S3I	3-57-0-A	SUPPLY DEPT. STORERO	64	0	0		
S3U		S3U	3-61-1-F	FUEL SERVICE TANK	80	0	0		
S3U		S3U	3-61-1-F	FUEL SERVICE TANK	64	0	0		

Table B.2 Barrier Data

Barrier Materials			Plan ID	Compartment Name Adjacent Compartment	Area sq ft	Therm adj	Durab adj	Doors / Hatches	DC Rating
<1>	<2>	<3>							
S2U	S5U		(none)	(weather bulkhead)	54.1	0	0		
S2U	S5U		(none)	(weather bulkhead)	144	0	0		
S3I	S5U		(none)	(weather bulkhead)	20.8	0	0		
S4U			3-61-1-F	FUEL SERVICE TANK	80	0	0		
S4U			2-57-0-L	PASSAGE	8	0	0		
S4U			2-57-1-Q	MACHINE SHOP	172.2	0	0		
S4U			2-59-1-Q	ELEC/ELEX WORKSHOP &	8	0	0		
			4-66-0-E	MAIN MACHINERY ROOM	(CUI = EM)				
S3I	S3U	S3U	4-57-0A-W	SW BALLAST TANK	28.8	0	0		
S3I	S3U	S3U	4-57-0A-W	SW BALLAST TANK	33.6	0	0		
S3I	S3U	S3U	4-57-0C-W	SW BALLAST TANK	28.8	0	0		
S3I	S3U	S3U	4-57-0C-W	SW BALLAST TANK	33.6	0	0		
S3I	S3U	S3U	4-60-1-F	LO DRAIN TANK	24	0	0		
S3I	S3U	S3U	4-60-2-F	OILY WATER TANK	24	0	0		
S2U		S2U	4-71-0-F	WASTE OIL TANK	14.4	0	0		
S2U		S2U	4-71-0-F	WASTE OIL TANK	18	0	0		
S2U		S2U	4-71-0-F	WASTE OIL TANK	14.4	0	0		
S2U		S2U	4-71-0-F	WASTE OIL TANK	18	0	0		
S2I		S2U	4-80-0-W	SEA BAY	6	0	0		
S2I		S2U	4-80-0-W	SEA BAY	15	0	0		
S2I		S2U	4-80-0-W	SEA BAY	3	0	0		
S2I		S2U	4-80-0-W	SEA BAY	6	0	0		
S2I		S2U	4-80-0-W	SEA BAY	3	0	0		
S2I		S2U	4-80-0-W	SEA BAY	15	0	0		
S2I		S2U	4-80-0-W	SEA BAY	6	0	0		
S3U	S3U	S3U	4-82-0-E	AUXILIARY MACHINERY	16.2	0	0		
S3U	S3U	S3U	4-82-0-E	AUXILIARY MACHINERY	16.2	0	0		
S3U	S3U	S3U	4-82-0-E	AUXILIARY MACHINERY	257.6	0	0		
S3U	S3U	S3U	4-82-0-E	AUXILIARY MACHINERY	279	0	0		
S3I	S3U	S3U	3-57-0-A	SUPPLY DEPT. STORERO	128	0	0		
S3I	S3U	S3U	3-61-1-F	FUEL SERVICE TANK	64	0	0		
S3I	S3U	S3U	3-62-2-F	FUEL SERVICE TANK	64	0	0		
S3U	S3U	S3U	2-57-0-L	PASSAGE	72	0	0		
S3U	S3U	S3U	2-57-1-Q	MACHINE SHOP	115.2	0	0		
S3U	S3U	S3U	2-57-4-E	WATER SUPPLY EQPT RO	133.2	0	0		
S3U	S3U	S3U	2-59-1-Q	ELEC/ELEX WORKSHOP &	90	0	0		
S3U		S3I	2-89-1-C	ENGINEERING CONTROL	232.2	0	0	2 DJ	NO
S3U		S3I	2-89-1-C	ENGINEERING CONTROL	113.4	0	0		
S2I	S5U		(none)	(weather bulkhead)	48.3	0	0		
S2I	S5U		(none)	(weather bulkhead)	48.5	0	0		
S2I	S5U		(none)	(weather bulkhead)	48.5	0	0		
S2I	S5U		(none)	(weather bulkhead)	48.3	0	0		
S2I	S5U		(none)	(weather bulkhead)	126.8	0	0		
S2I	S5U		(none)	(weather bulkhead)	128.4	0	0		
S2I	S5U		(none)	(weather bulkhead)	128.4	0	0		
S2I	S5U		(none)	(weather bulkhead)	127.1	0	0		
S2I	S5U		(none)	(weather bulkhead)	52.2	0	0		
S2I	S5U		(none)	(weather bulkhead)	144	0	0		
S2I	S5U		(none)	(weather bulkhead)	141	0	0		
S4U			4-71-0-F	WASTE OIL TANK	28.8	0	0		
S4U			4-80-0-W	SEA BAY	26	0	0		
S4U			2-89-1-C	ENGINEERING CONTROL	214.3	0	0	HO	O
S4I			1-60-6A-A	DRY PROVISION STORER	83.3	0	0		
S4I			1-66-0-L	CREW MESS	388.4	0	0		

Table B.2 Barrier Data

Barrier Materials			Plan ID	Compartment Name	Area sq ft	Therm adj	Durab adj	Doors / Hatches	DC Rating
<1>	<2>	<3>							
S4I			1-66-1-Q	GALLEY ANNEX	83.2	0	0		
S4I			1-66-2-L	COMPANIONWAY	52	0	0	HL	X
								HS	Z
S4I			1-66-3-Q	SCULLERY	50.5	0	0		
S4I			1-71-2-Q	ENG LOG OFFICE & DC	99.9	0	0		
S4I			1-74-2-Q	DC REPAIR LKR NO. 2	42	0	0		
000			1-76-0-Q	MMR (UPTAKE)	96	0	0		
S4I			1-77-1-A	CREW LOCKER	23.2	0	0		
S4I			1-77-2-L	CPO MESS & LOUNGE	134.5	0	0		
S4I			1-77-3-L	CREW LOUNGE	20	0	0		
S4I			1-80-1-E	VENT PLENUM	16.8	0	0		
			4-80-0-W	SEA BAY	(CUI = W)				
S2U		S2I	4-66-0-E	MAIN MACHINERY ROOM	6	0	0		
S2U		S2I	4-66-0-E	MAIN MACHINERY ROOM	15	0	0		
S2U		S2I	4-66-0-E	MAIN MACHINERY ROOM	3	0	0		
S2U		S2I	4-66-0-E	MAIN MACHINERY ROOM	6	0	0		
S2U		S2I	4-66-0-E	MAIN MACHINERY ROOM	3	0	0		
S2U		S2I	4-66-0-E	MAIN MACHINERY ROOM	15	0	0		
S2U		S2I	4-66-0-E	MAIN MACHINERY ROOM	6	0	0		
S2U	S2I	S2I	4-82-0-E	AUXILIARY MACHINERY	36	0	0		
S4U			4-66-0-E	MAIN MACHINERY ROOM	26	0	0		
			4-82-0-E	AUXILIARY MACHINERY ROOM	(CUI = QA)				
S3U	S3U	S3U	4-66-0-E	MAIN MACHINERY ROOM	16.2	0	0		
S3U	S3U	S3U	4-66-0-E	MAIN MACHINERY ROOM	16.2	0	0		
S3U	S3U	S3U	4-66-0-E	MAIN MACHINERY ROOM	257.6	0	0		
S3U	S3U	S3U	4-66-0-E	MAIN MACHINERY ROOM	279	0	0		
S2I	S2I	S2U	4-80-0-W	SEA BAY	36	0	0		
S3U	S3U	S3U	4-92-0-E	STERN THRUSTER MACHR	38.4	0	0		
S3U	S3U	S3U	4-92-0-E	STERN THRUSTER MACHR	176	0	0		
S3U	S3U	S3U	4-92-0-E	STERN THRUSTER MACHR	270	0	0		
S3U	S3U	S3I	2-89-1-C	ENGINEERING CONTROL	99	0	0		
S3U		S3U	1-76-0-Q	MMR (UPTAKE)	76	0	0		
S3U		S3U	1-82-0-L	PASSAGE	57	0	0		
S3U		S3I	1-82-1-L	CREW WR, WC & SH	57	0	0		
S3U		S3I	1-85-1-L	CREW SR	38	0	0		
S2U		S2U	1-85-2-Q	AFFF STA.	38	0	0		
S2I	S5U		(none)	(weather bulkhead)	61.9	0	0		
S2I	S5U		(none)	(weather bulkhead)	61.9	0	0		
S2I	S5U		(none)	(weather bulkhead)	164.9	0	0		
S2I	S5U		(none)	(weather bulkhead)	165.3	0	0		
S2I	S5U		(none)	(weather bulkhead)	42	0	0		
S2I	S5U		(none)	(weather bulkhead)	94	0	0		
S2I	S5U		(none)	(weather bulkhead)	54.3	0	0		
S2I	S5U		(none)	(weather bulkhead)	54.3	0	0		
S2I	S5U		(none)	(weather bulkhead)	94	0	0		
S2I	S5U		(none)	(weather bulkhead)	42	0	0		
S4U			1-76-0-Q	MMR (UPTAKE)	48	0	0		
S4I			1-82-0-L	PASSAGE	136	0	0	HS	Z
S4I			1-82-1-L	CREW WR, WC & SH	56.4	0	0		
S4I			1-82-2-Q	C.G. LKR W/ SINK	16	0	0		
S4I			1-82-3-L	CREW WR, WC & SH	43.8	0	0		
S4I			1-82-4-L	CREW WR, WC & SH	52.2	0	0		
S4I			1-84-2-L	COMPANIONWAY	48	0	0	HL	X
S4I			1-85-1-L	CREW SR	120	0	0		

Table B.2 Barrier Data

Barrier Materials			Plan ID	Compartment Name Adjacent Compartment	Area sq ft	Therm adj	Durab adj	Doors / Hatches	DC Rating
<1>	<2>	<3>							
S4I			1-85-2-Q	AFFF STA.	40	0	0		
S4I			1-85-3-L	CREW SR	93.8	0	0		
S4I			1-85-4-L	CREW SR	101.8	0	0		
			4-92-0-E	STERN THRUSTER MACHRY ROOM	(CUI = EM)				
S3U	S3U	S3U	4-82-0-E	AUXILIARY MACHINERY	38.4	0	0		
S3U	S3U	S3U	4-82-0-E	AUXILIARY MACHINERY	176	0	0		
S3U	S3U	S3U	4-82-0-E	AUXILIARY MACHINERY	270	0	0		
S2I	S5U		(none)	(weather bulkhead)	37.3	0	0		
S2I	S5U		(none)	(weather bulkhead)	37.3	0	0		
S3I	S5U		(none)	(weather bulkhead)	19.2	0	0		
S2I	S5U		(none)	(weather bulkhead)	56	0	0		
S2I	S5U		(none)	(weather bulkhead)	53.7	0	0		
S3I	S5U		(none)	(weather bulkhead)	70.4	0	0		
S2I	S5U		(none)	(weather bulkhead)	53.7	0	0		
S2I	S5U		(none)	(weather bulkhead)	56	0	0		
S2I	S5U		(none)	(weather bulkhead)	70.3	0	0		
S2I	S5U		(none)	(weather bulkhead)	67	0	0		
S2I	S5U		(none)	(weather bulkhead)	33.2	0	0		
S2I	S5U		(none)	(weather bulkhead)	33	0	0		
S2I	S5U		(none)	(weather bulkhead)	33	0	0		
S2I	S5U		(none)	(weather bulkhead)	33.2	0	0		
S2I	S5U		(none)	(weather bulkhead)	67	0	0		
S2I	S5U		(none)	(weather bulkhead)	70.3	0	0		
S4I			1-92-0-L	PASSAGE	151	0	0	2 HS	X
								HS	Z
S4I			1-92-1-L	CREW SR	15	0	0		
S4I			1-92-2-L	CREW SR	29.7	0	0		
S4I			1-96-0-L	CREW SR	76	0	0		
S4I			1-96-1-L	CREW WR, WC & SH	2.3	0	0		
			4-0-0-W	SW BALLAST TANK	(CUI = W)				
S3U	S3U	S3U	3-6-0-Q	CHAIN LOCKER SUMP	64	0	0		
S3U	S3U	S3U	4-6-0A-W	SW BALLAST TANK	33.6	0	0		
S3U	S3U	S3U	4-6-0A-W	SW BALLAST TANK	63	0	0		
S3U	S3U	S3U	4-6-0C-W	SW BALLAST TANK	33.6	0	0		
S3U	S3U	S3U	4-6-0C-W	SW BALLAST TANK	63	0	0		
S3U	S3U	S3U	2-6-1-Q	CHAIN LOCKER	36	0	0		
S3U	S3U	S3U	2-6-2-Q	CHAIN LOCKER	36	0	0		
S2I	S5U		(none)	(weather bulkhead)	48.7	0	0		
S2I	S5U		(none)	(weather bulkhead)	64.6	0	0		
S2I	S5U		(none)	(weather bulkhead)	64.6	0	0		
S2I	S5U		(none)	(weather bulkhead)	48.7	0	0		
S2U	S5U		(none)	(weather bulkhead)	53.9	0	0		
S2U	S5U		(none)	(weather bulkhead)	53.2	0	0		
S2U	S5U		(none)	(weather bulkhead)	34.6	0	0		
S2U	S5U		(none)	(weather bulkhead)	33	0	0		
S2U	S5U		(none)	(weather bulkhead)	33	0	0		
S2U	S5U		(none)	(weather bulkhead)	34.6	0	0		
S2U	S5U		(none)	(weather bulkhead)	53.2	0	0		
S2U	S5U		(none)	(weather bulkhead)	53.9	0	0		
S4U			1-0-0-A	BOATSWAIN STOREROOM	202.8	0	0		
S4U			(none)	(weather overhead)	6.9	0	0		
			3-6-0-Q	CHAIN LOCKER SUMP	(CUI = AG)				
S3U	S3U	S3U	4-0-0-W	SW BALLAST TANK	64	0	0		
S3I		S3U	4-6-0A-W	SW BALLAST TANK	58.2	0	0		

Table B.2 Barrier Data

Barrier Materials			Plan ID	Compartment Name Adjacent Compartment	Area sq ft	Therm adj	Durab adj	Doors / Hatches	DC Rating
<1>	<2>	<3>							
S3I		S3U	4-6-0B-W	SW BALLAST TANK	96	0	0		
S3I		S3U	4-6-0C-W	SW BALLAST TANK	58.2	0	0		
S4U			2-6-1-Q	CHAIN LOCKER	35	0	0		
S4U			2-6-2-Q	CHAIN LOCKER	35	0	0		
			4-6-0A-W	SW BALLAST TANK	(CUI = W)				
S3U	S3U	S3I	4-12-0-E	BOWTHRUSTER MCHRY RO	44.8	0	0		
S3U	S3U	S3I	4-12-0-E	BOWTHRUSTER MCHRY RO	59.4	0	0		
S3U	S3U	S3U	4-0-0-W	SW BALLAST TANK	33.6	0	0		
S3U	S3U	S3U	4-0-0-W	SW BALLAST TANK	63	0	0		
S3U		S3I	3-6-0-Q	CHAIN LOCKER SUMP	58.2	0	0		
000		000	4-6-0B-W	SW BALLAST TANK	28.8	0	0		
S3U		S3U	2-6-2-Q	CHAIN LOCKER	65.5	0	0		
S3U		S3U	2-10-0-F	HYD OIL STG TANK	32.4	0	0		
S2U	S5U		(none)	(weather bulkhead)	89.1	0	0		
S2U	S5U		(none)	(weather bulkhead)	102.6	0	0		
S2I	S5U		(none)	(weather bulkhead)	23.4	0	0		
S4U			1-6-2-A	FLAM. LIQ. STOREROOM	82.3	0	0		
			4-6-0B-W	SW BALLAST TANK	(CUI = W)				
S3U	S3U	S3I	4-12-0-E	BOWTHRUSTER MCHRY RO	96	0	0		
S3U		S3I	3-6-0-Q	CHAIN LOCKER SUMP	96	0	0		
000		000	4-6-0A-W	SW BALLAST TANK	28.8	0	0		
000		000	4-6-0C-W	SW BALLAST TANK	28.8	0	0		
S4U			2-10-0-F	HYD OIL STG TANK	43.2	0	0		
			4-6-0C-W	SW BALLAST TANK	(CUI = W)				
S3U	S3U	S3I	4-12-0-E	BOWTHRUSTER MCHRY RO	44.8	0	0		
S3U	S3U	S3I	4-12-0-E	BOWTHRUSTER MCHRY RO	59.4	0	0		
S3U	S3U	S3U	4-0-0-W	SW BALLAST TANK	33.6	0	0		
S3U	S3U	S3U	4-0-0-W	SW BALLAST TANK	63	0	0		
S3U		S3I	3-6-0-Q	CHAIN LOCKER SUMP	58.2	0	0		
000		000	4-6-0B-W	SW BALLAST TANK	28.8	0	0		
S3U		S3U	2-6-1-Q	CHAIN LOCKER	65.5	0	0		
S3U		S3U	2-10-0-F	HYD OIL STG TANK	32.4	0	0		
S2U	S5U		(none)	(weather bulkhead)	89.1	0	0		

Table B.2 Barrier Data

Barrier Materials			Plan ID	Compartment Name Adjacent Compartment	Area sq ft	Therm adj	Durab adj	Doors / Hatches	DC Rating
<1>	<2>	<3>							
			4-12-0-E	BOWTHRUSTER MCHRY ROOM	(CUI = EM)				
S3U	S3U	S3U	4-17-1-F	FUEL TANK	19.8	0	0		
S3I	S3U	S3U	4-17-1-F	FUEL TANK	105.6	0	0		
S3U	S3U	S3U	4-17-2-V	VOID	9	0	0		
S3I	S3U	S3U	4-17-2-V	VOID	24	0	0		
S3U	S3U	S3U	4-17-4-F	FUEL TANK	10.8	0	0		
S3I	S3U	S3U	4-17-4-F	FUEL TANK	81.6	0	0		
S3I	S3U	S3U	4-6-0A-W	SW BALLAST TANK	44.8	0	0		
S3I	S3U	S3U	4-6-0A-W	SW BALLAST TANK	59.4	0	0		
S3I	S3U	S3U	4-6-0B-W	SW BALLAST TANK	96	0	0		
S3I	S3U	S3U	4-6-0C-W	SW BALLAST TANK	44.8	0	0		
S3I	S3U	S3U	4-6-0C-W	SW BALLAST TANK	59.4	0	0		
S3I	S3U	S3U	2-10-0-F	HYD OIL STG TANK	108	0	0		
S3U		S3U	2-13-1-F	HPU RESERVOIR	39.6	0	0		
S3U		S3U	2-13-1-F	HPU RESERVOIR	80.4	0	0		
S3U		S3U	2-13-1-F	HPU RESERVOIR	18	0	0		
S3U		S3U	2-13-1-F	HPU RESERVOIR	77.4	0	0		
S3U		S3U	2-13-2-F	HPU RESERVOIR	39.6	0	0		
S3U		S3U	2-13-2-F	HPU RESERVOIR	77.4	0	0		
S3U		S3U	2-13-2-F	HPU RESERVOIR	18	0	0		
S3U		S3U	2-13-2-F	HPU RESERVOIR	80.4	0	0		
S3U	S3U	S3U	2-21-0-L	PASSAGE	162	0	0		
S3U	S3U	S3U	2-21-1-A	SUPPLY DEPT STOREROO	48.6	0	0		
S3U	S3U	S3U	2-21-2-Q	POTABLE WATER PUMP R	102.6	0	0		
S2I	S5U	(none)	(none)	(weather bulkhead)	27.4	0	0		
S2I	S5U	(none)	(none)	(weather bulkhead)	30	0	0		
S2I	S5U	(none)	(none)	(weather bulkhead)	27.4	0	0		
S2U	S5U	(none)	(none)	(weather bulkhead)	73.1	0	0		
S2I	S5U	(none)	(none)	(weather bulkhead)	73.1	0	0		
S2I	S5U	(none)	(none)	(weather bulkhead)	153.8	0	0		
S2I	S5U	(none)	(none)	(weather bulkhead)	153.8	0	0		
S4U			4-17-1-F	FUEL TANK	104.1	0	0		
S4U			4-17-2-V	VOID	22.2	0	0		
S4U			4-17-4-F	FUEL TANK	81.9	0	0		
S4U			2-13-1-F	HPU RESERVOIR	25.8	0	0		
S4U			2-13-2-F	HPU RESERVOIR	25.8	0	0		
S4U			1-12-1A-L	PASSAGE	80	0	0		
S4U			1-12-2-M	ARMORY	79.8	0	0		
S4U			1-12-3-Q	BOATSWAIN SHOP	67.2	0	0		
S4U			1-15-1-L	COMPANIONWAY	24.8	0	0	HL	X
								HS	Z
S4U			1-18-1-Q	D.C. REPAIR LKR NO.	46.5	0	0		
S4U			1-18-2-Q	AFFF STA.	36.8	0	0		
S4U			1-18-4-A	ATON STRM	87.5	0	0		
S4U			1-19-2-T	ESC TRUNK	14.4	0	0		
			4-17-2-V	VOID	(CUI = V)				
S3U	S3U	S3U	4-12-0-E	BOWTHRUSTER MCHRY RO	9	0	0		
S3U	S3U	S3I	4-12-0-E	BOWTHRUSTER MCHRY RO	24	0	0		
S3U		S3U	4-17-1-F	FUEL TANK	22.2	0	0		
S3U		S3U	4-17-1-F	FUEL TANK	59.2	0	0		
S3U		S3U	4-17-4-F	FUEL TANK	22.2	0	0		
S3U		S3U	4-17-4-F	FUEL TANK	59.2	0	0		
S3U	S3U	S3U	4-21-0B-W	SW BALLAST TANK	9	0	0		
S3U	S3U	S3I	3-21-0-L	PASSAGE	24	0	0		

Table B.2 Barrier Data

Barrier Materials			Plan ID	Compartment Name Adjacent Compartment	Area sq ft	Therm adj	Durab adj	Doors / Hatches	DC Rating
<1>	<2>	<3>							
S4U			4-12-0-E	BOWTHRUSTER MCHRY RO	22.2	0	0		
			4-21-0A-W	SW BALLAST TANK	(CUI = W)				
S3U	S3U	S3U	4-17-4-F	FUEL TANK	16.2	0	0		
S3U	S3U	S3U	4-17-4-F	FUEL TANK	75.2	0	0		
000		000	4-21-0B-W	SW BALLAST TANK	27	0	0		
000		000	4-21-0B-W	SW BALLAST TANK	23	0	0		
S3U	S3U	S3U	4-30-2-F	FUEL TANK	12	0	0		
S3U	S3U	S3U	4-30-2-F	FUEL TANK	32	0	0		
S3U	S3U	S3U	4-30-4-W	SW BALLAST TANK	10.8	0	0		
S3U	S3U	S3U	4-30-4-W	SW BALLAST TANK	56	0	0		
S3U		S3I	3-21-0-L	PASSAGE	61.3	0	0		
S3U		S3I	3-25-2-M	MAGAZINE NO. 2	72	0	0		
S2U	S5U		(none)	(weather bulkhead)	50.8	0	0		
S2U	S5U		(none)	(weather bulkhead)	134.3	0	0		
S4U			2-21-2-Q	POTABLE WATER PUMP R	158.3	0	0		
			4-21-0B-W	SW BALLAST TANK	(CUI = W)				
S3U	S3U	S3U	4-17-1-F	FUEL TANK	18	0	0		
S3U	S3U	S3U	4-17-2-V	VOID	9	0	0		
S3U	S3U	S3U	4-17-4-F	FUEL TANK	9	0	0		
000		000	4-21-0A-W	SW BALLAST TANK	27	0	0		
000		000	4-21-0A-W	SW BALLAST TANK	23	0	0		
000		000	4-21-0C-W	SW BALLAST TANK	27	0	0		
000		000	4-21-0C-W	SW BALLAST TANK	23	0	0		
S3U	S3U	S3U	4-30-0-F	FUEL TANK	48	0	0		
S4U			3-21-0-L	PASSAGE	71.6	0	0		
S4I			3-23-0-Q	CRANE PEDESTAL	64	0	0		
S4U			3-25-1-M	MAGAZINE NO. 1	56	0	0		
S4U			3-25-2-M	MAGAZINE NO. 2	56	0	0		
			4-21-0C-W	SW BALLAST TANK	(CUI = W)				
S3U	S3U	S3U	4-17-1-F	FUEL TANK	16.2	0	0		
S3U	S3U	S3U	4-17-1-F	FUEL TANK	75.2	0	0		
000		000	4-21-0B-W	SW BALLAST TANK	27	0	0		
000		000	4-21-0B-W	SW BALLAST TANK	23	0	0		
S3U	S3U	S3U	4-30-1-F	FUEL TANK	12	0	0		
S3U	S3U	S3U	4-30-1-F	FUEL TANK	32	0	0		
S3U	S3U	S3U	4-30-3-W	SW BALLAST TANK	10.8	0	0		
S3U	S3U	S3U	4-30-3-W	SW BALLAST TANK	56	0	0		
S3U		S3I	3-21-0-L	PASSAGE	61.3	0	0		
S3U		S3I	3-25-1-M	MAGAZINE NO. 1	72	0	0		
S2U	S5U		(none)	(weather bulkhead)	50.8	0	0		
S2U	S5U		(none)	(weather bulkhead)	134.3	0	0		
S4U			2-21-0-L	PASSAGE	73	0	0		
S4U			2-21-1-A	SUPPLY DEPT STOREROO	85.3	0	0		
			4-30-3-W	SW BALLAST TANK	(CUI = W)				
S3U	S3U	S3U	4-21-0C-W	SW BALLAST TANK	10.8	0	0		
S3U	S3U	S3U	4-21-0C-W	SW BALLAST TANK	56	0	0		
S3U		S3U	4-30-1-F	FUEL TANK	55	0	0		
S3U		S3U	4-30-1-F	FUEL TANK	146.9	0	0		
S3U	S3U	S3U	4-39-0C-V	VOID	43.2	0	0		
S3U	S5U		(none)	(weather bulkhead)	9.6	0	0		
S2U	S5U		(none)	(weather bulkhead)	54.7	0	0		
S2U	S5U		(none)	(weather bulkhead)	145.3	0	0		
S4U			2-30-0-AA	CARGO HOLD	85.2	0	0		
S4U			2-36-1-L	PASSAGE	30	0	0		

Table B.2 Barrier Data

Barrier Materials			Plan ID	Compartment Name Adjacent Compartment	Area sq ft	Therm adj	Durab adj	Doors / Hatches	DC Rating
<1>	<2>	<3>							
			4-30-4-W	SW BALLAST TANK	(CUI = W)				
S3U	S3U	S3U	4-21-0A-W	SW BALLAST TANK	10.8	0	0		
S3U	S3U	S3U	4-21-0A-W	SW BALLAST TANK	56	0	0		
S3U		S3U	4-30-2-F	FUEL TANK	55.1	0	0		
S3U		S3U	4-30-2-F	FUEL TANK	146.9	0	0		
S3U	S3U	S3U	4-39-0A-V	VOID	43.2	0	0		
S3U	S5U		(none)	(weather bulkhead)	9	0	0		
S2U	S5U		(none)	(weather bulkhead)	54.7	0	0		
S3U	S5U		(none)	(weather bulkhead)	145.3	0	0		
S4U			2-30-0-AA	CARGO HOLD	115.2	0	0		
			4-37-2-V	VOID	(CUI = V)				
S3U		S3U	4-30-0-F	FUEL TANK	12	0	0		
S3U		S3U	4-30-0-F	FUEL TANK	12	0	0		
S3U		S3U	4-30-0-F	FUEL TANK	12	0	0		
S3U		S3U	4-30-0-F	FUEL TANK	32	0	0		
S3U		S3U	4-30-0-F	FUEL TANK	32	0	0		
S3U		S3U	4-30-0-F	FUEL TANK	32	0	0		
S3U	S3U	S3U	4-39-0-V	VOID	12	0	0		
S3U	S3U	S3U	3-39-0-FF	SOR TANK	32	0	0		
S4U			2-30-0-AA	CARGO HOLD	16	0	0		
			4-39-0-V	VOID	(CUI = V)				
S3U	S3U	S3U	4-30-0-F	FUEL TANK	24	0	0		
S3U	S3U	S3U	4-30-0-F	FUEL TANK	12	0	0		
S3U	S3U	S3U	4-30-1-F	FUEL TANK	22.2	0	0		
S3U	S3U	S3U	4-30-2-F	FUEL TANK	22.8	0	0		
S3U	S3U	S3U	4-37-2-V	VOID	12	0	0		
S3U	S3U	S3U	4-48-0A-W	SW BALLAST TANK	4.8	0	0		
S2I	S3U	S3U	4-48-0B-W	SW BALLAST TANK	96	0	0		
S3U	S3U	S3U	4-48-0C-W	SW BALLAST TANK	4.8	0	0		
S2U	S5U		(none)	(weather bulkhead)	54.4	0	0		
S2U	S5U		(none)	(weather bulkhead)	54.3	0	0		
S4U			3-39-0-FF	SOR TANK	573.8	0	0		
S4U			4-39-0A-V	VOID	11.5	0	0		
S4U			4-39-0C-V	VOID	10.5	0	0		
			4-48-0A-W	SW BALLAST TANK	(CUI = W)				
S3U	S3U	S3U	4-39-0-V	VOID	4.8	0	0		
000		000	4-48-0B-W	SW BALLAST TANK	54	0	0		
S3U	S3U	S3U	4-57-0A-W	SW BALLAST TANK	7.2	0	0		
S3U	S3U	S3U	4-57-0A-W	SW BALLAST TANK	56	0	0		
S3U	S3U	S3U	4-39-0A-V	VOID	52.8	0	0		
S3U		S3U	3-48-2-F	FUEL TANK	144	0	0		
S2U	S5U		(none)	(weather bulkhead)	54	0	0		
S2U	S5U		(none)	(weather bulkhead)	144	0	0		
S3U	S5U		(none)	(weather bulkhead)	7.2	0	0		
S3U	S5U		(none)	(weather bulkhead)	7.8	0	0		
S4U			2-48-2-E	SOR PUMP ROOM	122.4	0	0		
			4-48-0B-W	SW BALLAST TANK	(CUI = W)				
S3U	S3U	S2I	4-39-0-V	VOID	96	0	0		
000		000	4-48-0A-W	SW BALLAST TANK	54	0	0		
000		000	4-48-0C-W	SW BALLAST TANK	54	0	0		
S3U	S3U	S3U	4-57-0A-W	SW BALLAST TANK	24	0	0		
S3U	S3U	S3U	4-57-0B-W	SW BALLAST TANK	48	0	0		
S3U	S3U	S3U	4-57-0C-W	SW BALLAST TANK	24	0	0		
S4U			3-48-0-FF	CARGO FUEL TANK	96	0	0		

Table B.2 Barrier Data

Barrier Materials			Plan ID	Compartment Name	Area sq ft	Therm adj	Durab adj	Doors / Hatches	DC Rating
<1>	<2>	<3>							
S4U			3-48-1-F	FUEL TANK	144	0	0		
S4U			3-48-2-F	FUEL TANK	144	0	0		
S4U			3-51-0-V	VOID	96	0	0		
S4U			3-54-0-F	FUEL OIL OVFL TANK	96	0	0		
			4-48-0C-W	SW BALLAST TANK	(CUI = W)				
S3U	S3U	S3U	4-39-0-V	VOID	4.8	0	0		
000		000	4-48-0B-W	SW BALLAST TANK	54	0	0		
S3U	S3U	S3U	4-57-0C-W	SW BALLAST TANK	7.2	0	0		
S3U	S3U	S3U	4-57-0C-W	SW BALLAST TANK	56	0	0		
S3U	S3U	S3U	4-39-0C-V	VOID	52.8	0	0		
S3U		S3U	3-48-1-F	FUEL TANK	144	0	0		
S2U	S5U		(none)	(weather bulkhead)	54	0	0		
S3U	S5U		(none)	(weather bulkhead)	144	0	0		
S3U	S5U		(none)	(weather bulkhead)	7.2	0	0		
S3U	S5U		(none)	(weather bulkhead)	7.8	0	0		
S4U			2-48-1-L	PASSAGE	26.6	0	0		
S4U			2-50-1-A	ENGINEER STOREROOM	95.8	0	0		
			4-57-0A-W	SW BALLAST TANK	(CUI = W)				
S3U	S3U	S3U	4-48-0A-W	SW BALLAST TANK	7.2	0	0		
S3U	S3U	S3U	4-48-0A-W	SW BALLAST TANK	56	0	0		
S3U	S3U	S3U	4-48-0B-W	SW BALLAST TANK	24	0	0		
S3U		S3U	4-57-0B-W	SW BALLAST TANK	18	0	0		
S3U		S3U	4-60-2-F	OILY WATER TANK	36	0	0		
S3U	S3U	S3I	4-66-0-E	MAIN MACHINERY ROOM	28.8	0	0		
S3U	S3U	S3I	4-66-0-E	MAIN MACHINERY ROOM	33.6	0	0		
S3U	S3U	S3U	3-48-2-F	FUEL TANK	64	0	0		
S3U		S3I	3-57-0-A	SUPPLY DEPT. STORERO	80	0	0		
S3U		S3U	3-62-2-F	FUEL SERVICE TANK	64	0	0		
S3U		S3U	3-62-2-F	FUEL SERVICE TANK	64	0	0		
S2U	S5U		(none)	(weather bulkhead)	54.1	0	0		
S2U	S5U		(none)	(weather bulkhead)	144	0	0		
S3I	S5U		(none)	(weather bulkhead)	20.8	0	0		
S4U			3-62-2-F	FUEL SERVICE TANK	64	0	0		
S4U			2-57-2-A	SHIP STORE	80	0	0		
S4U			2-57-4-E	WATER SUPPLY EQPT RO	124.2	0	0		
			4-57-0B-W	SW BALLAST TANK	(CUI = W)				
S3U	S3U	S3U	4-48-0B-W	SW BALLAST TANK	48	0	0		
S3U		S3U	4-57-0A-W	SW BALLAST TANK	18	0	0		
S3U		S3U	4-57-0C-W	SW BALLAST TANK	18	0	0		
S3U		S3U	4-60-1-F	LO DRAIN TANK	24	0	0		
S3U		S3U	4-60-2-F	OILY WATER TANK	24	0	0		
S4U			3-57-0-A	SUPPLY DEPT. STORERO	96	0	0		
			4-57-0C-W	SW BALLAST TANK	(CUI = W)				
S3U	S3U	S3U	4-48-0B-W	SW BALLAST TANK	24	0	0		
S3U	S3U	S3U	4-48-0C-W	SW BALLAST TANK	7.2	0	0		
S3U	S3U	S3U	4-48-0C-W	SW BALLAST TANK	56	0	0		
S3U		S3U	4-57-0B-W	SW BALLAST TANK	18	0	0		
S3U		S3U	4-60-1-F	LO DRAIN TANK	36	0	0		
S3U	S3U	S3I	4-66-0-E	MAIN MACHINERY ROOM	28.8	0	0		
S3U	S3U	S3J	4-66-0-E	MAIN MACHINERY ROOM	33.6	0	0		
S3U	S3U	S3U	3-48-1-F	FUEL TANK	64	0	0		
S3U		S3I	3-57-0-A	SUPPLY DEPT. STORERO	64	0	0		
S3U		S3U	3-61-1-F	FUEL SERVICE TANK	80	0	0		
S3U		S3U	3-61-1-F	FUEL SERVICE TANK	64	0	0		

Table B.2 Barrier Data

Barrier Materials			Plan ID	Compartment Name	Area sq ft	Them adj	Durab adj	Doors / Hatches	DC Rating
<1>	<2>	<3>							
S2U	S5U		(none)	(weather bulkhead)	54.1	0	0		
S2U	S5U		(none)	(weather bulkhead)	144	0	0		
S3I	S5U		(none)	(weather bulkhead)	20.8	0	0		
S4U			3-61-1-F	FUEL SERVICE TANK	80	0	0		
S4U			2-57-0-L	PASSAGE	8	0	0		
S4U			2-57-1-Q	MACHINE SHOP	172.2	0	0		
S4U			2-59-1-Q	ELEC/ELEX WORKSHOP &	8	0	0		
			4-66-0-E	MAIN MACHINERY ROOM (CUI = EM)					
S3I	S3U	S3U	4-57-0A-W	SW BALLAST TANK	28.8	0	0		
S3I	S3U	S3U	4-57-0A-W	SW BALLAST TANK	33.6	0	0		
S3I	S3U	S3U	4-57-0C-W	SW BALLAST TANK	28.8	0	0		
S3I	S3U	S3U	4-57-0C-W	SW BALLAST TANK	33.6	0	0		
S3I	S3U	S3U	4-60-1-F	LO DRAIN TANK	24	0	0		
S3I	S3U	S3U	4-60-2-F	OILY WATER TANK	24	0	0		
S2U		S2U	4-71-0-F	WASTE OIL TANK	14.4	0	0		
S2U		S2U	4-71-0-F	WASTE OIL TANK	18	0	0		
S2U		S2U	4-71-0-F	WASTE OIL TANK	14.4	0	0		
S2U		S2U	4-71-0-F	WASTE OIL TANK	18	0	0		
S2I		S2U	4-80-0-W	SEA BAY	6	0	0		
S2I		S2U	4-80-0-W	SEA BAY	15	0	0		
S2I		S2U	4-80-0-W	SEA BAY	3	0	0		
S2I		S2U	4-80-0-W	SEA BAY	6	0	0		
S2I		S2U	4-80-0-W	SEA BAY	3	0	0		
S2I		S2U	4-80-0-W	SEA BAY	15	0	0		
S2I		S2U	4-80-0-W	SEA BAY	6	0	0		
S3U	S3U	S3U	4-82-0-E	AUXILIARY MACHINERY	16.2	0	0		
S3U	S3U	S3U	4-82-0-E	AUXILIARY MACHINERY	16.2	0	0		
S3U	S3U	S3U	4-82-0-E	AUXILIARY MACHINERY	257.6	0	0		
S3U	S3U	S3U	4-82-0-E	AUXILIARY MACHINERY	279	0	0		
S3I	S3U	S3U	3-57-0-A	SUPPLY DEPT. STORERO	128	0	0		
S3I	S3U	S3U	3-61-1-F	FUEL SERVICE TANK	64	0	0		
S3I	S3U	S3U	3-62-2-F	FUEL SERVICE TANK	64	0	0		
S3U	S3U	S3U	2-57-0-L	PASSAGE	72	0	0		
S3U	S3U	S3U	2-57-1-Q	MACHINE SHOP	115.2	0	0		
S3U	S3U	S3U	2-57-4-E	WATER SUPPLY EQPT RO	133.2	0	0		
S3U	S3U	S3U	2-59-1-Q	ELEC/ELEX WORKSHOP &	90	0	0		
S3U		S3I	2-89-1-C	ENGINEERING CONTROL	232.2	0	0	2 DJ	NO
S3U		S3I	2-89-1-C	ENGINEERING CONTROL	113.4	0	0		
S2I	S5U		(none)	(weather bulkhead)	48.3	0	0		
S2I	S5U		(none)	(weather bulkhead)	48.5	0	0		
S2I	S5U		(none)	(weather bulkhead)	48.5	0	0		
S2I	S5U		(none)	(weather bulkhead)	48.3	0	0		
S2I	S5U		(none)	(weather bulkhead)	126.8	0	0		
S2I	S5U		(none)	(weather bulkhead)	128.4	0	0		
S2I	S5U		(none)	(weather bulkhead)	128.4	0	0		
S2I	S5U		(none)	(weather bulkhead)	127.1	0	0		
S2I	S5U		(none)	(weather bulkhead)	52.2	0	0		
S2I	S5U		(none)	(weather bulkhead)	144	0	0		
S2I	S5U		(none)	(weather bulkhead)	141	0	0		
S4U			4-71-0-F	WASTE OIL TANK	28.8	0	0		
S4U			4-80-0-W	SEA BAY	26	0	0		
S4U			2-89-1-C	ENGINEERING CONTROL	214.3	0	0	HO	O
S4I			1-60-6A-A	DRY PROVISION STORER	83.3	0	0		
S4I			1-66-0-L	CREW MESS	388.4	0	0		

Table B.2 Barrier Data

Barrier Materials			Plan ID	Compartment Name	Area sq ft	Therm adj	Durab adj	Doors / Hatches	DC Rating
<1>	<2>	<3>							
S4I			1-66-1-Q	GALLEY ANNEX	83.2	0	0		
S4I			1-66-2-L	COMPANIONWAY	52	0	0	HL	X
								HS	Z
S4I			1-66-3-Q	SCULLERY	50.5	0	0		
S4I			1-71-2-Q	ENG LOG OFFICE & DC	99.9	0	0		
S4I			1-74-2-Q	DC REPAIR LKR NO. 2	42	0	0		
000			1-76-0-Q	MMR (UPTAKE)	96	0	0		
S4I			1-77-1-A	CREW LOCKER	23.2	0	0		
S4I			1-77-2-L	CPO MESS & LOUNGE	134.5	0	0		
S4I			1-77-3-L	CREW LOUNGE	20	0	0		
S4I			1-80-1-E	VENT PLENUM	16.8	0	0		
			4-80-0-W	SEA BAY	(CUI = W)				
S2U		S2I	4-66-0-E	MAIN MACHINERY ROOM	6	0	0		
S2U		S2I	4-66-0-E	MAIN MACHINERY ROOM	15	0	0		
S2U		S2I	4-66-0-E	MAIN MACHINERY ROOM	3	0	0		
S2U		S2I	4-66-0-E	MAIN MACHINERY ROOM	6	0	0		
S2U		S2I	4-66-0-E	MAIN MACHINERY ROOM	3	0	0		
S2U		S2I	4-66-0-E	MAIN MACHINERY ROOM	15	0	0		
S2U		S2I	4-66-0-E	MAIN MACHINERY ROOM	6	0	0		
S2U	S2I	S2I	4-82-0-E	AUXILIARY MACHINERY	36	0	0		
S4U			4-66-0-E	MAIN MACHINERY ROOM	26	0	0		
			4-82-0-E	AUXILIARY MACHINERY ROOM	(CUI = QA)				
S3U	S3U	S3U	4-66-0-E	MAIN MACHINERY ROOM	16.2	0	0		
S3U	S3U	S3U	4-66-0-E	MAIN MACHINERY ROOM	16.2	0	0		
S3U	S3U	S3U	4-66-0-E	MAIN MACHINERY ROOM	257.6	0	0		
S3U	S3U	S3U	4-66-0-E	MAIN MACHINERY ROOM	279	0	0		
S2I	S2I	S2U	4-80-0-W	SEA BAY	36	0	0		
S3U	S3U	S3U	4-92-0-E	STERN THRUSTER MACHR	38.4	0	0		
S3U	S3U	S3U	4-92-0-E	STERN THRUSTER MACHR	176	0	0		
S3U	S3U	S3U	4-92-0-E	STERN THRUSTER MACHR	270	0	0		
S3U	S3U	S3I	2-89-1-C	ENGINEERING CONTROL	99	0	0		
S3U		S3U	1-76-0-Q	MMR (UPTAKE)	76	0	0		
S3U		S3U	1-82-0-L	PASSAGE	57	0	0		
S3U		S3I	1-82-1-L	CREW WR, WC & SH	57	0	0		
S3U		S3I	1-85-1-L	CREW SR	38	0	0		
S2U		S2U	1-85-2-Q	AFFF STA.	38	0	0		
S2I	S5U		(none)	(weather bulkhead)	61.9	0	0		
S2I	S5U		(none)	(weather bulkhead)	61.9	0	0		
S2I	S5U		(none)	(weather bulkhead)	164.9	0	0		
S2I	S5U		(none)	(weather bulkhead)	165.3	0	0		
S2I	S5U		(none)	(weather bulkhead)	42	0	0		
S2I	S5U		(none)	(weather bulkhead)	94	0	0		
S2I	S5U		(none)	(weather bulkhead)	54.3	0	0		
S2I	S5U		(none)	(weather bulkhead)	54.3	0	0		
S2I	S5U		(none)	(weather bulkhead)	94	0	0		
S2I	S5U		(none)	(weather bulkhead)	42	0	0		
S4U			1-76-0-Q	MMR (UPTAKE)	48	0	0		
S4I			1-82-0-L	PASSAGE	136	0	0	HS	Z
S4I			1-82-1-L	CREW WR, WC & SH	56.4	0	0		
S4I			1-82-2-Q	C.G. LKR W/ SINK	16	0	0		
S4I			1-82-3-L	CREW WR, WC & SH	43.8	0	0		
S4I			1-82-4-L	CREW WR, WC & SH	52.2	0	0		
S4I			1-84-2-L	COMPANIONWAY	48	0	0	HL	X
S4I			1-85-1-L	CREW SR	120	0	0		

Table B.2 Barrier Data

Barrier Materials			Plan ID	Compartment Name	Area sq ft	Therm adj	Durab adj	Doors / Hatches	DC Rating
<1>	<2>	<3>							
S4I			1-85-2-Q	AFFF STA.	40	0	0		
S4I			1-85-3-L	CREW SR	93.8	0	0		
S4I			1-85-4-L	CREW SR	101.8	0	0		
			4-92-0-E	STERN THRUSTER MACHRY ROOM	(CUI = EM)				
S3U	S3U	S3U	4-82-0-E	AUXILIARY MACHINERY	38.4	0	0		
S3U	S3U	S3U	4-82-0-E	AUXILIARY MACHINERY	176	0	0		
S3U	S3U	S3U	4-82-0-E	AUXILIARY MACHINERY	270	0	0		
S2I	S5U		(none)	(weather bulkhead)	37.3	0	0		
S2I	S5U		(none)	(weather bulkhead)	37.3	0	0		
S3I	S5U		(none)	(weather bulkhead)	19.2	0	0		
S2I	S5U		(none)	(weather bulkhead)	56	0	0		
S2I	S5U		(none)	(weather bulkhead)	53.7	0	0		
S3I	S5U		(none)	(weather bulkhead)	70.4	0	0		
S2I	S5U		(none)	(weather bulkhead)	53.7	0	0		
S2I	S5U		(none)	(weather bulkhead)	56	0	0		
S2I	S5U		(none)	(weather bulkhead)	70.3	0	0		
S2I	S5U		(none)	(weather bulkhead)	67	0	0		
S2I	S5U		(none)	(weather bulkhead)	33.2	0	0		
S2I	S5U		(none)	(weather bulkhead)	33	0	0		
S2I	S5U		(none)	(weather bulkhead)	33.2	0	0		
S2I	S5U		(none)	(weather bulkhead)	67	0	0		
S2I	S5U		(none)	(weather bulkhead)	70.3	0	0		
S4I			1-92-0-L	PASSAGE	151	0	0	2 HS	X
								HS	Z
S4I			1-92-1-L	CREW SR	15	0	0		
S4I			1-92-2-L	CREW SR	29.7	0	0		
S4I			1-96-0-L	CREW SR	76	0	0		
S4I			1-96-1-L	CREW WR, WC & SH	2.3	0	0		
			4-0-0-W	SW BALLAST TANK	(CUI = W)				
S3U	S3U	S3U	3-6-0-Q	CHAIN LOCKER SUMP	64	0	0		
S3U	S3U	S3U	4-6-0A-W	SW BALLAST TANK	33.6	0	0		
S3U	S3U	S3U	4-6-0A-W	SW BALLAST TANK	63	0	0		
S3U	S3U	S3U	4-6-0C-W	SW BALLAST TANK	33.6	0	0		
S3U	S3U	S3U	4-6-0C-W	SW BALLAST TANK	63	0	0		
S3U	S3U	S3U	2-6-1-Q	CHAIN LOCKER	36	0	0		
S3U	S3U	S3U	2-6-2-Q	CHAIN LOCKER	36	0	0		
S2I	S5U		(none)	(weather bulkhead)	48.7	0	0		
S2I	S5U		(none)	(weather bulkhead)	64.6	0	0		
S2I	S5U		(none)	(weather bulkhead)	64.6	0	0		
S2I	S5U		(none)	(weather bulkhead)	48.7	0	0		
S2U	S5U		(none)	(weather bulkhead)	53.9	0	0		
S2U	S5U		(none)	(weather bulkhead)	53.2	0	0		
S2U	S5U		(none)	(weather bulkhead)	34.6	0	0		
S2U	S5U		(none)	(weather bulkhead)	33	0	0		
S2U	S5U		(none)	(weather bulkhead)	33	0	0		
S2U	S5U		(none)	(weather bulkhead)	34.6	0	0		
S2U	S5U		(none)	(weather bulkhead)	53.2	0	0		
S2U	S5U		(none)	(weather bulkhead)	53.9	0	0		
S4U			1-0-0-A	BOATSWAIN STOREROOM	202.8	0	0		
S4U			(none)	(weather overhead)	6.9	0	0		
			3-6-0-Q	CHAIN LOCKER SUMP	(CUI = AG)				
S3U	S3U	S3U	4-0-0-W	SW BALLAST TANK	64	0	0		
S3I		S3U	4-6-0A-W	SW BALLAST TANK	58.2	0	0		

Table B.2 Barrier Data

Barrier Materials			Plan ID	Compartment Name Adjacent Compartment	Area sq ft	Therm adj	Durab adj	Doors / Hatches	DC Rating
<1>	<2>	<3>							
S3I		S3U	4-6-0B-W	SW BALLAST TANK	96	0	0		
S3I		S3U	4-6-0C-W	SW BALLAST TANK	58.2	0	0		
S4U			2-6-1-Q	CHAIN LOCKER	35	0	0		
S4U			2-6-2-Q	CHAIN LOCKER	35	0	0		
			4-6-0A-W	SW BALLAST TANK	(CUI = W)				
S3U	S3U	S3I	4-12-0-E	BOWTHRUSTER MCHRY RO	44.8	0	0		
S3U	S3U	S3I	4-12-0-E	BOWTHRUSTER MCHRY RO	59.4	0	0		
S3U	S3U	S3U	4-0-0-W	SW BALLAST TANK	33.6	0	0		
S3U	S3U	S3U	4-0-0-W	SW BALLAST TANK	63	0	0		
S3U		S3I	3-6-0-Q	CHAIN LOCKER SUMP	58.2	0	0		
000		000	4-6-0B-W	SW BALLAST TANK	28.8	0	0		
S3U		S3U	2-6-2-Q	CHAIN LOCKER	65.5	0	0		
S3U		S3U	2-10-0-F	HYD OIL STG TANK	32.4	0	0		
S2U	S5U		(none)	(weather bulkhead)	89.1	0	0		
S2U	S5U		(none)	(weather bulkhead)	102.6	0	0		
S2I	S5U		(none)	(weather bulkhead)	23.4	0	0		
S4U			1-6-2-A	FLAM. LIQ. STOREROOM	82.3	0	0		
			4-6-0B-W	SW BALLAST TANK	(CUI = W)				
S3U	S3U	S3I	4-12-0-E	BOWTHRUSTER MCHRY RO	96	0	0		
S3U		S3I	3-6-0-Q	CHAIN LOCKER SUMP	96	0	0		
000		000	4-6-0A-W	SW BALLAST TANK	28.8	0	0		
000		000	4-6-0C-W	SW BALLAST TANK	28.8	0	0		
S4U			2-10-0-F	HYD OIL STG TANK	43.2	0	0		
			4-6-0C-W	SW BALLAST TANK	(CUI = W)				
S3U	S3U	S3I	4-12-0-E	BOWTHRUSTER MCHRY RO	44.8	0	0		
S3U	S3U	S3I	4-12-0-E	BOWTHRUSTER MCHRY RO	59.4	0	0		
S3U	S3U	S3U	4-0-0-W	SW BALLAST TANK	33.6	0	0		
S3U	S3U	S3U	4-0-0-W	SW BALLAST TANK	63	0	0		
S3U		S3I	3-6-0-Q	CHAIN LOCKER SUMP	58.2	0	0		
000		000	4-6-0B-W	SW BALLAST TANK	28.8	0	0		
S3U		S3U	2-6-1-Q	CHAIN LOCKER	65.5	0	0		
S3U		S3U	2-10-0-F	HYD OIL STG TANK	32.4	0	0		
S2U	S5U		(none)	(weather bulkhead)	89.1	0	0		
S2U	S5U		(none)	(weather bulkhead)	102.6	0	0		
S2I	S5U		(none)	(weather bulkhead)	23.4	0	0		
S4U			1-6-1-A	BOATSWAIN STOREROOM	82.3	0	0		
			3-21-0-L	PASSAGE	(CUI = LP)				
S3I	S3U	S3U	4-17-1-F	FUEL TANK	48	0	0		
S3I	S3U	S3U	4-17-2-V	VOID	24	0	0		
S3I	S3U	S3U	4-17-4-F	FUEL TANK	24	0	0		
S3I		S3U	4-21-0A-W	SW BALLAST TANK	61.3	0	0		
S3I		S3U	4-21-0C-W	SW BALLAST TANK	61.3	0	0		
S3U		S3U	3-23-0-Q	CRANE PEDESTAL	32	0	0		
S3U		S3U	3-23-0-Q	CRANE PEDESTAL	64	0	0		
S3U		S3U	3-23-0-Q	CRANE PEDESTAL	32	0	0	DWT	X
S3U		S3U	3-25-1-M	MAGAZINE NO. 1	32	0	0	DJ	INC
S3U		S3U	3-25-2-M	MAGAZINE NO. 2	32	0	0	DJ	INC
S4U			4-21-0B-W	SW BALLAST TANK	71.6	0	0		
S4U			2-21-0-L	PASSAGE	64.2	0	0		
S4U			2-21-2-Q	POTABLE WATER PUMP R	7.4	0	0	HS	X
			3-23-0-Q	CRANE PEDESTAL	(CUI = TH)				
S3U		S3U	3-21-0-L	PASSAGE	32	0	0		
S3U		S3U	3-21-0-L	PASSAGE	64	0	0		
S3U		S3U	3-21-0-L	PASSAGE	32	0	0	DWT	X

Table B.2 Barrier Data

Barrier Materials			Plan ID	Compartment Name	Area sq ft	Therm adj	Durab adj	Doors / Hatches	DC Rating
<1>	<2>	<3>							
S3U		S3U	3-25-1-M	MAGAZINE NO. 1	32	0	0		
S3U		S3U	3-25-1-M	MAGAZINE NO. 1	32	0	0		
S3U		S3U	3-25-2-M	MAGAZINE NO. 2	32	0	0		
S3U		S3U	3-25-2-M	MAGAZINE NO. 2	32	0	0		
S3U		S3U	2-21-0-L	PASSAGE	36	0	0		
S3U		S3U	2-21-0-L	PASSAGE	72	0	0		
S3U		S3U	2-21-0-L	PASSAGE	36	0	0		
S3I		S3U	2-25-1-WW	POTABLE WATER (CARGO	36	0	0		
S3I		S3U	2-25-1-WW	POTABLE WATER (CARGO	36	0	0		
S3I		S3U	2-25-2-W	POTABLE WATER (SHIP)	36	0	0		
S3I		S3U	2-25-2-W	POTABLE WATER (SHIP)	36	0	0		
S3U		S3U	1-21-1-L	VESTIBULE	38	0	0		
S3U		S3U	1-21-1-L	VESTIBULE	38	0	0		
S3U		S3U	1-21-2-Q	ATON SHOP	38	0	0		
S3U		S3U	1-21-2-Q	ATON SHOP	38	0	0		
S3I	S3U		(none)	(weather bulkhead)	76	0	0		
S3I	S3U		(none)	(weather bulkhead)	38	0	0		
S3I	S3U		(none)	(weather bulkhead)	38	0	0		
S4I			4-21-0B-W	SW BALLAST TANK	64	0	0		
S4U			01-27-0-C	BUOY DECK CONTROL BO	12.8	0	0		
S4U			(none)	(weather overhead)	51.2	0	0		
			4-39-0A-V	VOID	(CUI = V)				
S3U	S3U	S3U	4-30-4-W	SW BALLAST TANK	43.2	0	0		
S3U	S3U	S3U	4-48-0A-W	SW BALLAST TANK	52.8	0	0		
S3U		S3U	3-39-0-FF	SOR TANK	144	0	0		
S2U	S5U		(none)	(weather bulkhead)	144.3	0	0		
S4U			4-39-0-V	VOID	11.5	0	0		
S4U			2-39-2-V	VOID	108	0	0		
			4-39-0C-V	VOID	(CUI = V)				
S3U	S3U	S3U	4-30-3-W	SW BALLAST TANK	43.2	0	0		
S3U	S3U	S3U	4-48-0C-W	SW BALLAST TANK	52.8	0	0		
S3U		S3U	3-39-0-FF	SOR TANK	144	0	0		
S2U	S5U		(none)	(weather bulkhead)	144.3	0	0		
S4U			4-39-0-V	VOID	10.5	0	0		
S4U			2-39-1-L	PASSAGE	108	0	0		
			3-51-0-V	VOID	(CUI = V)				
S3U		S3U	3-48-0-FF	CARGO FUEL TANK	128	0	0		
S3U		S3U	3-48-1-F	FUEL TANK	48	0	0		
S3U		S3U	3-48-2-F	FUEL TANK	48	0	0		
S3U		S3U	3-54-0-F	FUEL OIL OVFL TANK	128	0	0		
S4U			4-48-0B-W	SW BALLAST TANK	96	0	0		
S4U			2-48-1-L	PASSAGE	8	0	0		
S4U			2-49-0-E	SOR MACHINERY ROOM	84	0	0		
S4U			2-53-1-L	VESTIBULE	4	0	0		
			3-57-0-A	SUPPLY DEPT. STOREROOM NO. 2	(CUI = AS)				
S3I		S3U	4-57-0A-W	SW BALLAST TANK	80	0	0		
S3I		S3U	4-57-0C-W	SW BALLAST TANK	64	0	0		
S3U	S3U	S3I	4-66-0-E	MAIN MACHINERY ROOM	128	0	0		
S3I	S3U	S3U	3-54-0-F	FUEL OIL OVFL TANK	128	0	0		
S3I		S3U	3-61-1-F	FUEL SERVICE TANK	80	0	0		
S3I		S3U	3-62-2-F	FUEL SERVICE TANK	64	0	0		
S4U			4-57-0B-W	SW BALLAST TANK	96	0	0		
S4I			4-60-1-F	LO DRAIN TANK	96	0	0		
S4I			4-60-2-F	OILY WATER TANK	96	0	0		

Table B.2 Barrier Data

Barrier Materials			Plan ID	Compartment Name Adjacent Compartment	Area sq ft	Therm adj	Durab adj	Doors / Hatches	DC Rating
<1>	<2>	<3>							
S4U			2-57-0-L	PASSAGE	176	0	0	HL	X
S4U			2-59-1-Q	ELEC/ELEX WORKSHOP &	112	0	0		
			2-6-1-Q	CHAIN LOCKER	(CUI = AG)				
S3U	S3U	S3U	4-0-0-W	SW BALLAST TANK	36	0	0		
S3U		S3U	4-6-0C-W	SW BALLAST TANK	65.5	0	0		
S3U		S3U	2-6-2-Q	CHAIN LOCKER	63	0	0		
S3U		S3U	2-10-0-F	HYD OIL STG TANK	54	0	0		
S4U			3-6-0-Q	CHAIN LOCKER SUMP	35	0	0		
S4U			1-6-1-A	BOATSWAIN STOREROOM	31.8	0	0		
S4U			1-12-1B-L	PASSAGE	3.2	0	0		
			2-6-2-Q	CHAIN LOCKER	(CUI = AG)				
S3U	S3U	S3U	4-0-0-W	SW BALLAST TANK	36	0	0		
S3U		S3U	4-6-0A-W	SW BALLAST TANK	65.5	0	0		
S3U		S3U	2-6-1-Q	CHAIN LOCKER	63	0	0		
S3U		S3U	2-10-0-F	HYD OIL STG TANK	54	0	0		
S4U			3-6-0-Q	CHAIN LOCKER SUMP	35	0	0		
S4U			1-6-2-A	FLAM. LIQ. STOREROOM	35	0	0		
			2-21-0-L	PASSAGE	(CUI = LP)				
S3U	S3U	S3U	4-12-0-E	BOWTHRUSTER MCHRY RO	162	0	0		
S3U		S3U	3-23-0-Q	CRANE PEDESTAL	36	0	0		
S3U		S3U	3-23-0-Q	CRANE PEDESTAL	72	0	0		
S3U		S3U	3-23-0-Q	CRANE PEDESTAL	36	0	0		
000		000	2-21-1-A	SUPPLY DEPT STOREROO	147.6	0	0	DJ	NC
S3U		S3U	2-21-2-Q	POTABLE WATER PUMP R	66.6	0	0	DJ	NC
S3I		S3U	2-25-1-WW	POTABLE WATER (CARGO	36	0	0		
S3I		S3U	2-25-1-WW	POTABLE WATER (CARGO	81	0	0		
S3I		S3U	2-25-2-W	POTABLE WATER (SHIP)	18	0	0		
S3U	S3U	S3U	2-30-0-AA	CARGO HOLD	36	0	0	DWT	X
S4U			4-21-0C-W	SW BALLAST TANK	73	0	0		
S4U			3-21-0-L	PASSAGE	64.2	0	0		
S4U			1-21-1-L	VESTIBULE	43.2	0	0		
S4U			1-21-2-Q	ATON SHOP	28.4	0	0		
S4U			1-21-3-L	COMPANIONWAY	29.6	0	0	HL	X
								HS	Z
S4U			(none)	(weather overhead)	36	0	0		
			2-21-1-A	SUPPLY DEPT STOREROOM NO. 1	(CUI = AS)				
S3U	S3U	S3U	4-12-0-E	BOWTHRUSTER MCHRY RO	48.6	0	0		
000		000	2-21-0-L	PASSAGE	147.6	0	0	DJ	NC
S3U	S3U	S3U	2-30-0-AA	CARGO HOLD	75.6	0	0		
S2I	S5U		(none)	(weather bulkhead)	150.1	0	0		
S4U			4-21-0C-W	SW BALLAST TANK	85.3	0	0		
S4U			1-21-3-L	COMPANIONWAY	45	0	0		
S4U			(none)	(weather overhead)	68.2	0	0		
			2-21-2-Q	POTABLE WATER PUMP ROOM	(CUI = QA)				
S3U	S3U	S3U	4-12-0-E	BOWTHRUSTER MCHRY RO	102.6	0	0		
S3U		S3U	2-21-0-L	PASSAGE	66.6	0	0	DJ	NC
S3I		S3U	2-25-2-W	POTABLE WATER (SHIP)	81	0	0		
S3I		S3U	2-25-2-W	POTABLE WATER (SHIP)	18	0	0		
S3U	S3U	S3U	2-30-0-AA	CARGO HOLD	111.6	0	0		
S2I	S5U		(none)	(weather bulkhead)	150.1	0	0		
S4U			4-21-0A-W	SW BALLAST TANK	158.3	0	0		
S4U			3-21-0-L	PASSAGE	7.4	0	0	HS	X
S4U			1-21-2-Q	ATON SHOP	89.4	0	0		
S4U			(none)	(weather overhead)	104.2	0	0		

Table B.2 Barrier Data

Barrier Materials			Plan ID	Compartment Name Adjacent Compartment	Area sq ft	Therm adj	Durab adj	Doors / Hatches	DC Rating
<1>	<2>	<3>							
			2-25-1-WW	POTABLE WATER (CARGO)	(CUI = W)				
S3U		S3I	3-23-0-Q	CRANE PEDESTAL	36	0	0		
S3U		S3I	3-23-0-Q	CRANE PEDESTAL	36	0	0		
S3U		S3I	2-21-0-L	PASSAGE	36	0	0		
S3U		S3I	2-21-0-L	PASSAGE	81	0	0		
S3U		S3U	2-25-2-W	POTABLE WATER (SHIP)	45	0	0		
S3U	S3U	S3U	2-30-0-AA	CARGO HOLD	72	0	0		
S4U			3-25-1-M	MAGAZINE NO. 1	56	0	0		
S4U			(none)	(weather overhead)	56	0	0		
			2-25-2-W	POTABLE WATER (SHIP)	(CUI = W)				
S3U		S3I	3-23-0-Q	CRANE PEDESTAL	36	0	0		
S3U		S3I	3-23-0-Q	CRANE PEDESTAL	36	0	0		
S3U		S3I	2-21-0-L	PASSAGE	18	0	0		
S3U		S3I	2-21-2-Q	POTABLE WATER PUMP R	81	0	0		
S3U		S3I	2-21-2-Q	POTABLE WATER PUMP R	18	0	0		
S3U		S3U	2-25-1-WW	POTABLE WATER (CARGO)	45	0	0		
S3U	S3U	S3U	2-30-0-AA	CARGO HOLD	72	0	0		
S4U			3-25-2-M	MAGAZINE NO. 2	56	0	0		
S4U			(none)	(weather overhead)	56	0	0		
			2-30-0-AA	CARGO HOLD	(CUI = AA)				
S3U	S3U	S3U	2-21-0-L	PASSAGE	36	0	0	DWT	X
S3U	S3U	S3U	2-21-1-A	SUPPLY DEPT STOREROO	75.6	0	0		
S3U	S3U	S3U	2-21-2-Q	POTABLE WATER PUMP R	111.6	0	0		
S3U	S3U	S3U	2-25-1-WW	POTABLE WATER (CARGO)	72	0	0		
S3U	S3U	S3U	2-25-2-W	POTABLE WATER (SHIP)	72	0	0		
S3U		S3U	2-36-1-L	PASSAGE	54	0	0	DJ	NC
S3U		S3U	2-36-1-L	PASSAGE	50.4	0	0		
S3U	S3U	S3U	2-39-0-V	COFFERDAM	288	0	0		
S3U	S3U	S3U	2-39-2-V	VOID	61.2	0	0		
S2I	S5U		(none)	(weather bulkhead)	108.5	0	0		
S2I	S5U		(none)	(weather bulkhead)	56.1	0	0		
S2I	S5U		(none)	(weather bulkhead)	57.4	0	0		
S4U			4-30-0-F	FUEL TANK	272	0	0		
S4U			4-30-1-F	FUEL TANK	104.4	0	0		
S4U			4-30-2-F	FUEL TANK	104.4	0	0		
S4U			4-30-3-W	SW BALLAST TANK	85.2	0	0		
S4U			4-30-4-W	SW BALLAST TANK	115.2	0	0		
S4U			4-37-2-V	VOID	16	0	0		
S4I			(none)	(weather overhead)	734.8	0	0	HL	X
			2-36-1-L	PASSAGE	(CUI = LP)				
S3U		S3U	2-30-0-AA	CARGO HOLD	54	0	0	DJ	NC
S3U		S3U	2-30-0-AA	CARGO HOLD	50.4	0	0		
S3U	S3U	S3U	2-39-1-L	PASSAGE	48.6	0	0	DWT	Z
S2I	S5U		(none)	(weather bulkhead)	54	0	0		
S4U			4-30-3-W	SW BALLAST TANK	30	0	0		
S4I			(none)	(weather overhead)	33	0	0		
			2-39-0-V	COFFERDAM	(CUI = V)				
S3U		S3U	3-39-0-FF	SOR TANK	288	0	0		
S3U	S3U	S3U	2-30-0-AA	CARGO HOLD	288	0	0		
S3U		S3I	2-39-1-L	PASSAGE	18	0	0		
S3U		S3I	2-39-2-V	VOID	18	0	0		
S4U			3-39-0-FF	SOR TANK	64	0	0		
S4I			(none)	(weather overhead)	64	0	0		
			2-39-1-L	PASSAGE	(CUI = LP)				

Table B.2 Barrier Data

Barrier Materials			Plan ID	Compartment Name Adjacent Compartment	Area sq ft	Therm adj	Durab adj	Doors / Hatches	DC Rating
<1>	<2>	<3>							
S3I		S3U	3-39-0-FF	SOR TANK	144	0	0		
S3U	S3U	S3U	2-36-1-L	PASSAGE	48.6	0	0	DWT	Z
S3I		S3U	2-39-0-V	COFFERDAM	18	0	0		
S3U	S3U	S3U	2-48-1-L	PASSAGE	63	0	0	DWT	Z
S2I	S5U		(none)	(weather bulkhead)	162.6	0	0		
S4U			4-39-0C-V	VOID	108	0	0		
S4I			(none)	(weather overhead)	111.6	0	0		
			2-39-2-V	VOID	(CUI = V)				
S3I		S3U	3-39-0-FF	SOR TANK	144	0	0		
S3U	S3U	S3U	2-30-0-AA	CARGO HOLD	61.2	0	0		
S3I		S3U	2-39-0-V	COFFERDAM	18	0	0		
S3U	S3U	S3I	2-48-2-E	SOR PUMP ROOM	63	0	0		
S2U	S5U		(none)	(weather bulkhead)	162	0	0		
S4U			4-39-0A-V	VOID	108	0	0		
S4I			(none)	(weather overhead)	124.2	0	0		
			2-48-0-V	COFFERDAM	(CUI = V)				
S3U	S3U	S3U	3-39-0-FF	SOR TANK	126	0	0		
S3U		S3I	2-48-1-L	PASSAGE	18	0	0		
S3U		S3I	2-48-2-E	SOR PUMP ROOM	18	0	0		
S3U		S3I	2-49-0-E	SOR MACHINERY ROOM	126	0	0		
S4U			3-48-0-FF	CARGO FUEL TANK	28	0	0		
S4I			(none)	(weather overhead)	28	0	0		
			2-48-1-L	PASSAGE	(CUI = LP)				
S3I	S3U	S3U	3-39-0-FF	SOR TANK	90	0	0		
S3U	S3U	S3U	2-39-1-L	PASSAGE	63	0	0	DWT	Z
S3I		S3U	2-48-0-V	COFFERDAM	18	0	0		
S3U		S3U	2-49-0-E	SOR MACHINERY ROOM	72	0	0		
000		000	2-50-1-A	ENGINEER STOREROOM	54	0	0	DJ	NO
000		000	2-50-1-A	ENGINEER STOREROOM	117	0	0		
S3U		S3U	2-53-1-L	VESTIBULE	36	0	0	DJ	NC
S2I	S5U		(none)	(weather bulkhead)	36	0	0		
S4U			4-48-0C-W	SW BALLAST TANK	26.6	0	0		
S4U			3-48-0-FF	CARGO FUEL TANK	12	0	0		
S4U			3-48-1-F	FUEL TANK	44	0	0		
S4U			3-51-0-V	VOID	8	0	0		
S4I			(none)	(weather overhead)	92	0	0		
			2-48-2-E	SOR PUMP ROOM	(CUI = QA)				
S3I	S3U	S3U	3-39-0-FF	SOR TANK	72	0	0		
S3I	S3U	S3U	2-39-2-V	VOID	63	0	0		
S3I		S3U	2-48-0-V	COFFERDAM	18	0	0		
S3U		S3U	2-49-0-E	SOR MACHINERY ROOM	144	0	0		
S3U	S3U	S3U	2-57-2-A	SHIP STORE	72	0	0		
S3U	S3U	S3U	2-57-4-E	WATER SUPPLY EQPT RO	63	0	0		
S2I	S5U		(none)	(weather bulkhead)	162	0	0		
S4U			4-48-0A-W	SW BALLAST TANK	122.4	0	0		
S4U			3-48-2-F	FUEL TANK	144	0	0		
S4I			(none)	(weather overhead)	270	0	0	HS	X
			2-49-0-E	SOR MACHINERY ROOM	(CUI = QA)				
S3I		S3U	2-48-0-V	COFFERDAM	126	0	0		
S3U		S3U	2-48-1-L	PASSAGE	72	0	0		
S3U		S3U	2-48-2-E	SOR PUMP ROOM	144	0	0		
S3U		S3U	2-53-1-L	VESTIBULE	36	0	0		
S3U		S3U	2-53-1-L	VESTIBULE	36	0	0		
S3U		S3U	2-53-1-L	VESTIBULE	36	0	0	DJ	NC

Table B.2 Barrier Data

Barrier Materials			Plan ID	Compartment Name Adjacent Compartment	Area sq ft	Therm adj	Durab adj	Doors / Hatches	DC Rating
<1>	<2>	<3>							
S3U	S3U	S3U	2-57-0-L	PASSAGE	90	0	0		
S4U			3-48-0-FF	CARGO FUEL TANK	56	0	0		
S4U			3-51-0-V	VOID	84	0	0		
S4U			3-54-0-F	FUEL OIL OVFL TANK	68	0	0		
S4I			(none)	(weather overhead)	208	0	0		
			2-50-1-A	ENGINEER STOREROOM	(CUI = AS)				
000		000	2-48-1-L	PASSAGE	54	0	0	DJ	NO
000		000	2-48-1-L	PASSAGE	117	0	0		
S3U		S3U	2-53-1-L	VESTIBULE	72	0	0		
S3U	S3U	S3U	2-57-1-Q	MACHINE SHOP	117	0	0		
S2I	S5U		(none)	(weather bulkhead)	126	0	0		
S4U			4-48-0C-W	SW BALLAST TANK	95.8	0	0		
S4U			3-48-1-F	FUEL TANK	84	0	0		
S4I			(none)	(weather overhead)	182	0	0		
			2-53-1-L	VESTIBULE	(CUI = LP)				
S3U		S3U	2-48-1-L	PASSAGE	36	0	0	DJ	NC
S3U		S3U	2-49-0-E	SOR MACHINERY ROOM	36	0	0		
S3U		S3U	2-49-0-E	SOR MACHINERY ROOM	36	0	0		
S3U		S3U	2-49-0-E	SOR MACHINERY ROOM	36	0	0	DJ	NC
S3U		S3U	2-50-1-A	ENGINEER STOREROOM	72	0	0		
S3U	S3U	S3U	2-57-0-L	PASSAGE	72	0	0	DWT	Z
S4U			3-48-1-F	FUEL TANK	16	0	0		
S4U			3-51-0-V	VOID	4	0	0		
S4U			3-54-0-F	FUEL OIL OVFL TANK	28	0	0		
S4I			(none)	(weather overhead)	48	0	0	HS	X
			2-57-0-L	PASSAGE	(CUI = LP)				
S3U	S3U	S3U	4-66-0-E	MAIN MACHINERY ROOM	72	0	0		
S3U	S3U	S3U	2-49-0-E	SOR MACHINERY ROOM	90	0	0		
S3U	S3U	S3U	2-53-1-L	VESTIBULE	72	0	0	DWT	Z
S3U		S3U	2-57-1-Q	MACHINE SHOP	36	0	0	DJ	NC
NPU		S2U	2-57-2-A	SHIP STORE	91.8	0	0	DJ	NO
NPU		S3U	2-57-4-E	WATER SUPPLY EQPT RO	70.2	0	0	DJ	NC
S3U		S3U	2-59-1-Q	ELEC/ELEX WORKSHOP &	126	0	0		
S3U		S3U	2-59-1-Q	ELEC/ELEX WORKSHOP &	90	0	0	DJ	NC
S4U			4-57-0C-W	SW BALLAST TANK	8	0	0		
S4U			3-57-0-A	SUPPLY DEPT. STORERO	176	0	0	HL	X
S4U			1-57-0-L	DECK WR & WC	32	0	0		
S4U			1-57-1-Q	GALLEY	18	0	0		
S4U			1-57-2-L	PASSAGE	88	0	0		
S4U			1-57-3-Q	DUMBWAITER TRUNK	6	0	0		
S4U			1-59-2-L	COMPANIONWAY	40	0	0	HL	X
								HS	Z
			2-57-1-Q	MACHINE SHOP	(CUI = QS)				
S3U	S3U	S3U	4-66-0-E	MAIN MACHINERY ROOM	115.2	0	0		
S3U	S3U	S3U	2-50-1-A	ENGINEER STOREROOM	117	0	0		
S3U		S3U	2-57-0-L	PASSAGE	36	0	0	DJ	NC
S3U		S3U	2-59-1-Q	ELEC/ELEX WORKSHOP &	126	0	0		
S2I	S5U		(none)	(weather bulkhead)	162	0	0		
S4U			4-57-0C-W	SW BALLAST TANK	172.2	0	0		
S4U			3-61-1-F	FUEL SERVICE TANK	60	0	0		
S4U			1-57-1-Q	GALLEY	229.2	0	0		
S4U			1-57-3-Q	DUMBWAITER TRUNK	3	0	0		
			2-57-2-A	SHIP STORE	(CUI = AS)				
S3U	S3U	S3U	2-48-2-E	SOR PUMP ROOM	72	0	0		

Table B.2 Barrier Data

Barrier Materials			Plan ID	Compartment Name Adjacent Compartment	Area sq ft	Therm adj	Durab adj	Doors / Hatches	DC Rating
<1>	<2>	<3>							
S2U		NPU	2-57-0-L	PASSAGE	91.8	0	0	DJ	NO
S3U		S3U	2-57-4-E	WATER SUPPLY EQPT RO	91.8	0	0		
S3U		S3U	2-57-4-E	WATER SUPPLY EQPT RO	72	0	0		
S4U			4-57-0A-W	SW BALLAST TANK	80	0	0		
S4U			1-57-2-L	PASSAGE	10.2	0	0		
S4U			1-57-4-Q	CHANGE ROOM	42	0	0		
S4U			1-60-2-A	CHILL STRM	25.2	0	0		
S4U			1-60-4-A	FREEZE STRM	4.2	0	0		
			2-57-4-E	WATER SUPPLY EQPT ROOM	(CUI = QA)				
S3U	S3U	S3U	4-66-0-E	MAIN MACHINERY ROOM	133.2	0	0		
S3U	S3U	S3U	2-48-2-E	SOR PUMP ROOM	63	0	0		
S3U		NPU	2-57-0-L	PASSAGE	70.2	0	0	DJ	NC
S3U		S3U	2-57-2-A	SHIP STORE	91.8	0	0		
S3U		S3U	2-57-2-A	SHIP STORE	72	0	0		
S2I	S5U		(none)	(weather bulkhead)	162	0	0		
S4U			4-57-0A-W	SW BALLAST TANK	124.2	0	0		
S4U			3-62-2-F	FUEL SERVICE TANK	62.4	0	0		
S4U			1-57-2-L	PASSAGE	7.8	0	0		
S4U			1-57-4-Q	CHANGE ROOM	41.8	0	0		
S4U			1-60-2-A	CHILL STRM	20.4	0	0		
S4U			1-60-4-A	FREEZE STRM	41.4	0	0		
S4U			1-60-6B-A	DRY PROVISION STORER	75.2	0	0		
			2-59-1-Q	ELEC/ELEX WORKSHOP & STORERM	(CUI = QS)				
S3U	S3U	S3U	4-66-0-E	MAIN MACHINERY ROOM	90	0	0		
S3U		S3U	2-57-0-L	PASSAGE	126	0	0		
S3U		S3U	2-57-0-L	PASSAGE	90	0	0	DJ	NC
S3U		S3U	2-57-1-Q	MACHINE SHOP	126	0	0		
S4U			4-57-0C-W	SW BALLAST TANK	8	0	0		
S4U			3-57-0-A	SUPPLY DEPT. STORERO	112	0	0		
S4U			3-61-1-F	FUEL SERVICE TANK	20	0	0		
S4U			1-57-0-L	DECK WR & WC	8	0	0		
S4U			1-57-1-Q	GALLEY	100	0	0		
S4U			1-60-1-L	GALLEY WR & WC	32	0	0		
			2-89-1-C	ENGINEERING CONTROL CENTER	(CUI = C)				
S3I		S3U	4-66-0-E	MAIN MACHINERY ROOM	232.2	0	0	DJ	NO
S3I		S3U	4-66-0-E	MAIN MACHINERY ROOM	113.4	0	0		
S3I	S3U	S3U	4-82-0-E	AUXILIARY MACHINERY	99	0	0		
S2I	S5U		(none)	(weather bulkhead)	232.7	0	0		
S4U			4-66-0-E	MAIN MACHINERY ROOM	214.3	0	0	HO	O
S4I			1-66-0-L	CREW MESS	155	0	0	HS	X
S4I			1-66-3-Q	SCULLERY	35.6	0	0		
S4I			1-77-3-L	CREW LOUNGE	113.1	0	0		
			1-0-0-A	BOATSWAIN STOREROOM NO. 1	(CUI = AS)				
S3U		S3U	1-6-1-A	BOATSWAIN STOREROOM	104.5	0	0		
S3U		S3U	1-6-2-A	FLAM. LIQ. STOREROOM	104.5	0	0		
S2I	S3U		(none)	(weather bulkhead)	113	0	0		
S2I	S3U		(none)	(weather bulkhead)	70.1	0	0		
S2I	S3U		(none)	(weather bulkhead)	70.1	0	0		
S2I	S3U		(none)	(weather bulkhead)	113	0	0		
S4U			4-0-0-W	SW BALLAST TANK	202.8	0	0		
S4I			(none)	(weather overhead)	202.8	0	0	HS	X
			1-6-1-A	BOATSWAIN STOREROOM NO. 2	(CUI = AS)				
S3U		S3U	1-0-0-A	BOATSWAIN STOREROOM	104.5	0	0		
S3U		S3U	1-6-2-A	FLAM. LIQ. STOREROOM	58.9	0	0		

Table B.2 Barrier Data

Barrier Materials			Plan ID	Compartment Name	Area sq ft	Therm adj	Durab adj	Doors / Hatches	DC Rating
<1>	<2>	<3>							
000		000	1-12-1B-L	PASSAGE	38	0	0		
000		000	1-12-1B-L	PASSAGE	41.8	0	0	DJ	NC
S3U		S3U	1-12-3-Q	BOATSWAIN SHOP	106.4	0	0		
S2I	S3U		(none)	(weather bulkhead)	108.3	0	0		
S4U			4-6-0C-W	SW BALLAST TANK	82.3	0	0		
S4U			2-6-1-Q	CHAIN LOCKER	31.8	0	0		
S4U			2-10-0-F	HYD OIL STG TANK	7.2	0	0		
S4I			(none)	(weather overhead)	121.3	0	0	HS	X
			1-6-2-A	FLAM. LIQ. STOREROOM	(CUI = K)				
S3U		S3U	1-0-0-A	BOATSWAIN STOREROOM	104.5	0	0		
S3U		S3U	1-6-1-A	BOATSWAIN STOREROOM	58.9	0	0		
S3U		S3U	1-12-1B-L	PASSAGE	41.8	0	0	DJ	NC
S3U		S3U	1-12-2-M	ARMORY	144.4	0	0		
S3U	S3U		(none)	(weather bulkhead)	108.3	0	0		
S4U			4-6-0A-W	SW BALLAST TANK	82.3	0	0		
S4U			2-6-2-Q	CHAIN LOCKER	35	0	0		
S4U			2-10-0-F	HYD OIL STG TANK	21.6	0	0		
S4I			(none)	(weather overhead)	138.9	0	0		
			1-12-1A-L	PASSAGE	(CUI = LP)				
S3U		S3U	1-12-1B-L	PASSAGE	38	0	0	DWT	X
S3U		S3U	1-12-2-M	ARMORY	68.4	0	0	DJ	NC
S3U		S3U	1-12-3-Q	BOATSWAIN SHOP	51.3	0	0	DJ	NC
S2U		S2U	1-15-1-L	COMPANIONWAY	70.3	0	0		
S2U		S2U	1-15-1-L	COMPANIONWAY	38	0	0	DJ	NC
S3U		S3U	1-18-1-Q	D.C. REPAIR LKR NO.	34.2	0	0	DJ	NC
000		000	1-18-2-Q	AFF STA.	87.4	0	0		
S3U		S3U	1-21-1-L	VESTIBULE	76	0	0	DWT	Z
S4U			4-12-0-E	BOWTHRUSTER MCHRY RO	80	0	0		
S4I			(none)	(weather overhead)	80	0	0		
			1-12-1B-L	PASSAGE	(CUI = LP)				
000		000	1-6-1-A	BOATSWAIN STOREROOM	38	0	0		
000		000	1-6-1-A	BOATSWAIN STOREROOM	41.8	0	0	DJ	NC
S3U		S3U	1-6-2-A	FLAM. LIQ. STOREROOM	41.8	0	0	DJ	NC
S3U		S3U	1-12-1A-L	PASSAGE	38	0	0	DWT	X
S4U			2-6-1-Q	CHAIN LOCKER	3.2	0	0		
S4U			2-10-0-F	HYD OIL STG TANK	14.4	0	0		
S4I			(none)	(weather overhead)	17.6	0	0		
			1-12-3-Q	BOATSWAIN SHOP	(CUI = QS)				
S3U		S3U	1-6-1-A	BOATSWAIN STOREROOM	106.4	0	0		
S3U		S3U	1-12-1A-L	PASSAGE	51.3	0	0	DJ	NC
S3U		S3U	1-15-1-L	COMPANIONWAY	38	0	0		
S3U		S3U	1-15-1-L	COMPANIONWAY	53.2	0	0		
S3U		S3U	1-18-1-Q	D.C. REPAIR LKR NO.	95	0	0		
S2I	S3U		(none)	(weather bulkhead)	107.8	0	0		
S4U			4-12-0-E	BOWTHRUSTER MCHRY RO	67.2	0	0		
S4U			2-13-1-F	HPU RESERVOIR	22.7	0	0		
S4I			(none)	(weather overhead)	116.2	0	0		
			1-15-1-L	COMPANIONWAY	(CUI = LP)				
S2U		S2U	1-12-1A-L	PASSAGE	70.3	0	0		
S2U		S2U	1-12-1A-L	PASSAGE	38	0	0	DJ	NC
S3U		S3U	1-12-3-Q	BOATSWAIN SHOP	38	0	0		
S3U		S3U	1-12-3-Q	BOATSWAIN SHOP	53.2	0	0		
S3U		S3U	1-18-1-Q	D.C. REPAIR LKR NO.	17.1	0	0		
S4U			4-12-0-E	BOWTHRUSTER MCHRY RO	24.8	0	0	HL	X

Table B.2 Barrier Data

Barrier Materials			Plan ID	Compartment Name Adjacent Compartment	Area sq ft	Therm adj	Durab adj	Doors / Hatches	DC Rating
<1>	<2>	<3>							
								HS	Z
S4U			2-13-1-F	HPU RESERVOIR	4.8	0	0		
S4I			(none)	(weather overhead)	29.6	0	0		
			1-18-1-Q	D.C. REPAIR LKR NO. 1	(CUI = QA)				
S3U		S3U	1-12-1A-L	PASSAGE	34.2	0	0	DJ	NC
S3U		S3U	1-12-3-Q	BOATSWAIN SHOP	95	0	0		
S3U		S3U	1-15-1-L	COMPANIONWAY	17.1	0	0		
S3U		S3U	1-21-3-L	COMPANIONWAY	108.3	0	0		
S2I	S3U		(none)	(weather bulkhead)	53	0	0		
S4U			4-12-0-E	BOWTHRUSTER MCHRY RO	46.5	0	0		
S4I			(none)	(weather overhead)	57.8	0	0		
			1-18-2-Q	AFFF STA.	(CUI = QA)				
000		000	1-12-1A-L	PASSAGE	87.4	0	0		
S3U		S3U	1-12-2-M	ARMORY	38	0	0		
S3U		S3U	1-18-4-A	ATON STRM	51.3	0	0		
S3U		S3U	1-19-2-T	ESC TRUNK	36.1	0	0		
S3U		S3U	1-21-2-Q	ATON SHOP	38	0	0		
S4U			4-12-0-E	BOWTHRUSTER MCHRY RO	36.8	0	0		
S4I			(none)	(weather overhead)	36.8	0	0		
			1-18-4-A	ATON STRM	(CUI = AS)				
S3U		S3U	1-12-2-M	ARMORY	127.3	0	0		
S3U		S3U	1-18-2-Q	AFFF STA.	51.3	0	0		
S3U		S3U	1-19-2-T	ESC TRUNK	36.1	0	0		
S3U		S3U	1-19-2-T	ESC TRUNK	36.1	0	0		
S3U		S3U	1-21-2-Q	ATON SHOP	110.2	0	0	DWT	Z
S2I	S3U		(none)	(weather bulkhead)	89.4	0	0		
S4U			4-12-0-E	BOWTHRUSTER MCHRY RO	87.5	0	0		
S4U			2-13-2-F	HPU RESERVOIR	9	0	0		
S4I			(none)	(weather overhead)	118	0	0		
			1-19-2-T	ESC TRUNK	(CUI = TH)				
S3U		S3U	1-18-2-Q	AFFF STA.	36.1	0	0		
S3U		S3U	1-18-4-A	ATON STRM	36.1	0	0		
S3U		S3U	1-18-4-A	ATON STRM	36.1	0	0		
S3U		S3U	1-21-2-Q	ATON SHOP	36.1	0	0		
S4U			4-12-0-E	BOWTHRUSTER MCHRY RO	14.4	0	0		
S4U			(none)	(weather overhead)	14.4	0	0	HS	X
			1-21-1-L	VESTIBULE	(CUI = LP)				
S3U		S3U	3-23-0-Q	CRANE PEDESTAL	38	0	0		
S3U		S3U	3-23-0-Q	CRANE PEDESTAL	38	0	0		
S3U		S3U	1-12-1A-L	PASSAGE	76	0	0	DWT	Z
S3U		S3U	1-21-2-Q	ATON SHOP	32.3	0	0		
S3U		S3U	1-21-3-L	COMPANIONWAY	70.3	0	0	DJ	NC
S3I	S3U		(none)	(weather bulkhead)	38	0	0	DWT	Z
S4U			2-21-0-L	PASSAGE	43.2	0	0		
S4I			(none)	(weather overhead)	43.2	0	0		
			1-21-2-Q	ATON SHOP	(CUI = QS)				
S3U		S3U	3-23-0-Q	CRANE PEDESTAL	38	0	0		
S3U		S3U	3-23-0-Q	CRANE PEDESTAL	38	0	0		
S3U		S3U	1-18-2-Q	AFFF STA.	38	0	0		
S3U		S3U	1-18-4-A	ATON STRM	110.2	0	0	DWT	Z
S3U		S3U	1-19-2-T	ESC TRUNK	36.1	0	0		
S3U		S3U	1-21-1-L	VESTIBULE	32.3	0	0		
S3I	S3U		(none)	(weather bulkhead)	157.7	0	0	DWT	Z
S2I	S3U		(none)	(weather bulkhead)	71.2	0	0		

Table B.2 Barrier Data

Barrier Materials			Plan ID	Compartment Name Adjacent Compartment	Area sq ft	Therm adj	Durab adj	Doors / Hatches	DC Rating
<1>	<2>	<3>							
S4U			2-21-0-L	PASSAGE	28.4	0	0		
S4U			2-21-2-Q	POTABLE WATER PUMP R	89.4	0	0		
S4I			(none)	(weather overhead)	132	0	0		
			1-21-3-L	COMPANIONWAY	(CUI = LP)				
S3U		S3U	1-18-1-Q	D.C. REPAIR LKR NO.	108.3	0	0		
S3U		S3U	1-21-1-L	VESTIBULE	70.3	0	0	DJ	NC
S3I	S3U		(none)	(weather bulkhead)	119.7	0	0		
S2I	S3U		(none)	(weather bulkhead)	71.2	0	0		
S4U			2-21-0-L	PASSAGE	29.6	0	0	HL	X
								HS	Z
S4U			2-21-1-A	SUPPLY DEPT STOREROO	45	0	0		
S4I			(none)	(weather overhead)	88.8	0	0		
			1-57-0-L	DECK WR & WC	(CUI = LW)				
S3U		S3U	1-57-1-Q	GALLEY	57	0	0		
S3U		S3U	1-57-2-L	PASSAGE	38	0	0	DJ	NC
S3U		S3U	1-59-2-L	COMPANIONWAY	38	0	0		
S3U		S3U	1-59-2-L	COMPANIONWAY	19	0	0		
NPU		NPU	1-60-1-L	GALLEY WR & WC	38	0	0		
S3I	S3U		(none)	(weather bulkhead)	76	0	0		
S4U			2-57-0-L	PASSAGE	32	0	0		
S4U			2-59-1-Q	ELEC/ELEX WORKSHOP &	8	0	0		
S4U			01-57-0-Q	WARD ROOM PANTRY	32	0	0		
S4U			01-57-2-L	CPO SR	8	0	0		
			1-57-1-Q	GALLEY	(CUI = QG)				
S3U		S3U	1-57-0-L	DECK WR & WC	57	0	0		
S3U		S3U	1-57-2-L	PASSAGE	38	0	0	DJ	NC
S3I		S3U	1-57-3-Q	DUMBWAITER TRUNK	28.5	0	0		
S3I		S3U	1-57-3-Q	DUMBWAITER TRUNK	28.5	0	0		
S3I		S3U	1-57-3-Q	DUMBWAITER TRUNK	28.5	0	0		
S3U		S3U	1-60-1-L	GALLEY WR & WC	76	0	0		
S3U		S3U	1-60-1-L	GALLEY WR & WC	38	0	0	DJ	NC
S3U		S3U	1-66-1-Q	GALLEY ANNEX	133	0	0	DWT	Z
S3U		S3U	1-66-3-Q	SCULLERY	85.5	0	0		
S2I	S3U		(none)	(weather bulkhead)	171	0	0		
S3I	S3U		(none)	(weather bulkhead)	114	0	0		
S3I	S3U		(none)	(weather bulkhead)	38	0	0		
S4U			2-57-0-L	PASSAGE	18	0	0		
S4U			2-57-1-Q	MACHINE SHOP	229.2	0	0		
S4U			2-59-1-Q	ELEC/ELEX WORKSHOP &	100	0	0		
S4U			01-57-0-Q	WARD ROOM PANTRY	75	0	0		
S4U			01-60-1-L	WARDROOM MESSROOM &	184	0	0		
S4U			(none)	(weather overhead)	90	0	0		
			1-57-2-L	PASSAGE	(CUI = LP)				
S3U		S3U	1-57-0-L	DECK WR & WC	38	0	0	DJ	NC
S3U		S3U	1-57-1-Q	GALLEY	38	0	0	DJ	NC
S3U		S3U	1-57-4-Q	CHANGE ROOM	57	0	0	DJ	NO
S3U		S3U	1-59-2-L	COMPANIONWAY	95	0	0	DJ	NC
S3U		S3U	1-59-2-L	COMPANIONWAY	38	0	0		
NPI		NPI	1-60-2-A	CHILL STRM	72.2	0	0		
S3U		S3U	1-60-6B-A	DRY PROVISION STORER	41.8	0	0	DJ	NO
S3U		S3U	1-66-0-L	CREW MESS	76	0	0	DWT	Z
S3U		S3U	1-66-2-L	COMPANIONWAY	9.5	0	0		
S3I	S3U		(none)	(weather bulkhead)	47.5	0	0	DWT	Z
S4U			2-57-0-L	PASSAGE	88	0	0		

Table B.2 Barrier Data

Barrier Materials			Plan ID	Compartment Name Adjacent Compartment	Area sq ft	Therm adj	Durab adj	Doors / Hatches	DC Rating
<1>	<2>	<3>							
S4U			2-57-2-A	SHIP STORE	10.2	0	0		
S4U			2-57-4-E	WATER SUPPLY EQPT RO	7.8	0	0		
S4U			01-57-2-L	CPO SR	42.6	0	0		
S4U			01-60-0C-L	PASSAGE	40	0	0		
S4U			01-83-2-L	CPO SR	23.4	0	0		
			1-57-3-Q	DUMBWAITER TRUNK	(CUI = TH)				
S3U		S3I	1-57-1-Q	GALLEY	28.5	0	0		
S3U		S3I	1-57-1-Q	GALLEY	28.5	0	0		
S3U		S3I	1-57-1-Q	GALLEY	28.5	0	0		
S3U		S3I	01-57-0-Q	WARD ROOM PANTRY	25.5	0	0		
S3U		S3I	01-57-0-Q	WARD ROOM PANTRY	25.5	0	0		
S3U		S3I	01-57-0-Q	WARD ROOM PANTRY	25.5	0	0		
S3U	S3U		(none)	(weather bulkhead)	28.5	0	0		
S3U	S3U		(none)	(weather bulkhead)	25.5	0	0		
S4U			2-57-0-L	PASSAGE	6	0	0		
S4U			2-57-1-Q	MACHINE SHOP	3	0	0		
S4U			02-57-0-L	CO CABIN	9	0	0		
			1-57-4-Q	CHANGE ROOM	(CUI = LW)				
S3U		S3U	1-57-2-L	PASSAGE	57	0	0	DJ	NO
S3U		NPI	1-60-2-A	CHILL STRM	57	0	0		
S3U		NPI	1-60-4-A	FREEZE STRM	57	0	0		
S3U		S3U	1-60-6B-A	DRY PROVISION STORER	19	0	0		
S3I	S3U		(none)	(weather bulkhead)	133	0	0		
S2I	S3U		(none)	(weather bulkhead)	57	0	0		
S4U			2-57-2-A	SHIP STORE	42	0	0		
S4U			2-57-4-E	WATER SUPPLY EQPT RO	41.8	0	0		
S4U			01-57-2-L	CPO SR	18	0	0		
S4U			01-57-4-L	CPO WR, WC, SH	36	0	0		
S4U			(none)	(weather overhead)	30	0	0		
			1-59-2-L	COMPANIONWAY	(CUI = LP)				
S3U		S3U	1-57-0-L	DECK WR & WC	38	0	0		
S3U		S3U	1-57-0-L	DECK WR & WC	19	0	0		
S3U		S3U	1-57-2-L	PASSAGE	95	0	0	DJ	NC
S3U		S3U	1-57-2-L	PASSAGE	38	0	0		
S3U		S3U	1-60-1-L	GALLEY WR & WC	76	0	0		
S4U			2-57-0-L	PASSAGE	40	0	0	HL	X
								HS	Z
S4U			01-57-0-Q	WARD ROOM PANTRY	4	0	0		
S4U			01-57-2-L	CPO SR	4	0	0		
S4U			01-60-0C-L	PASSAGE	32	0	0		
			1-60-1-L	GALLEY WR & WC	(CUI = LW)				
NPU		NPU	1-57-0-L	DECK WR & WC	38	0	0		
S3U		S3U	1-57-1-Q	GALLEY	76	0	0		
S3U		S3U	1-57-1-Q	GALLEY	38	0	0	DJ	NC
S3U		S3U	1-59-2-L	COMPANIONWAY	76	0	0		
S4U			2-59-1-Q	ELEC/ELEX WORKSHOP &	32	0	0		
S4U			01-60-1-L	WARDROOM MESSROOM &	32	0	0		
			1-60-2-A	CHILL STRM	(CUI = AR)				
NPI		NPI	1-57-2-L	PASSAGE	72.2	0	0		
NPI		S3U	1-57-4-Q	CHANGE ROOM	57	0	0		
NPI		NPI	1-60-4-A	FREEZE STRM	72.2	0	0		
NPI		NPI	1-60-6B-A	DRY PROVISION STORER	57	0	0	DJ	NC
S4U			2-57-2-A	SHIP STORE	25.2	0	0		
S4U			2-57-4-E	WATER SUPPLY EQPT RO	20.4	0	0		

Table B.2 Barrier Data

Barrier Materials			Plan ID	Compartment Name Adjacent Compartment	Area sq ft	Therm adj	Durab adj	Doors / Hatches	DC Rating
<1>	<2>	<3>							
S4U			01-57-2-L	CPO SR	12.6	0	0		
S4U			01-57-4-L	CPO WR, WC, SH	12.6	0	0		
S4U			01-83-2-L	CPO SR	20.4	0	0		
			1-60-4-A	FREEZE STRM	(CUI = AR)				
NPI		S3U	1-57-4-Q	CHANGE ROOM	57	0	0		
NPI		NPI	1-60-2-A	CHILL STRM	72.2	0	0		
NPI		NPI	1-60-6B-A	DRY PROVISION STORER	72.2	0	0		
NPI		NPI	1-60-6B-A	DRY PROVISION STORER	57	0	0	DJ	NC
S4U			2-57-2-A	SHIP STORE	4.2	0	0		
S4U			2-57-4-E	WATER SUPPLY EQPT RO	41.4	0	0		
S4U			01-57-4-L	CPO WR, WC, SH	12.6	0	0		
S4U			01-83-2-L	CPO SR	10.2	0	0		
S4U			(none)	(weather overhead)	22.8	0	0		
			1-60-6A-A	DRY PROVISION STOREROOM	(CUI = AS)				
S3U		S3U	1-60-6B-A	DRY PROVISION STORER	85.5	0	0	DJ	NC
S3U		S3U	1-66-2-L	COMPANIONWAY	91.2	0	0		
S3U		S3U	1-71-2-Q	ENG LOG OFFICE & DC	85.5	0	0		
S2I	S3U		(none)	(weather bulkhead)	91.2	0	0		
S4I			4-66-0-E	MAIN MACHINERY ROOM	83.3	0	0		
S4U			01-66-2-L	PASSAGE	24.8	0	0		
S4U			01-70-2-Q	C.G. LKR	13.6	0	0		
S4U			(none)	(weather overhead)	48	0	0		
			1-60-6B-A	DRY PROVISION STOREROOM	(CUI = AS)				
S3U		S3U	1-57-2-L	PASSAGE	41.8	0	0	DJ	NO
S3U		S3U	1-57-4-Q	CHANGE ROOM	19	0	0		
NPI		NPI	1-60-2-A	CHILL STRM	57	0	0	DJ	NC
NPI		NPI	1-60-4-A	FREEZE STRM	72.2	0	0		
NPI		NPI	1-60-4-A	FREEZE STRM	57	0	0	DJ	NC
S3U		S3U	1-60-6A-A	DRY PROVISION STORER	85.5	0	0	DJ	NC
S3I		S3U	1-66-2-L	COMPANIONWAY	47.5	0	0		
S2I	S3U		(none)	(weather bulkhead)	114	0	0		
S4U			2-57-4-E	WATER SUPPLY EQPT RO	75.2	0	0		
S4U			01-83-2-L	CPO SR	39.6	0	0		
S4U			(none)	(weather overhead)	37.2	0	0		
			1-66-0-L	CREW MESS	(CUI = LL)				
S3U		S3U	1-57-2-L	PASSAGE	76	0	0	DWT	Z
S3U		S3U	1-66-1-Q	GALLEY ANNEX	57	0	0		
S3U		S3U	1-66-1-Q	GALLEY ANNEX	133	0	0	2 DO	O
S3U		S3U	1-66-2-L	COMPANIONWAY	38	0	0	DJ	NC
S3U		S3U	1-66-2-L	COMPANIONWAY	9.5	0	0		
S3U		S3U	1-66-2-L	COMPANIONWAY	53.2	0	0		
S3U		S3U	1-66-2-L	COMPANIONWAY	47.5	0	0		
S3U		S3U	1-66-3-Q	SCULLERY	38	0	0		
S3U		S3U	1-66-3-Q	SCULLERY	85.5	0	0	DJ	NC
S2U		S2U	1-71-2-Q	ENG LOG OFFICE & DC	47.5	0	0	DJ	NC
S3U		S3U	1-74-2-Q	DC REPAIR LKR NO. 2	57	0	0		
S3U		S3U	1-74-2-Q	DC REPAIR LKR NO. 2	66.5	0	0	DJ	NC
S3I		S3U	1-76-0-Q	MMR (UPTAKE)	114	0	0		
S3I		S3U	1-76-0-Q	MMR (UPTAKE)	76	0	0		
S3U		S3U	1-76-0-Q	MMR (UPTAKE)	19	0	0		
S2U		S2U	1-77-1-A	CREW LOCKER	38	0	0	DJ	NO
S2U		S2U	1-77-2-L	CPO MESS & LOUNGE	95	0	0	DJ	NC
NSU		NPU	1-77-3-L	CREW LOUNGE	142.5	0	0	DJ	NO
S3U		S3U	1-82-0-L	PASSAGE	38	0	0	DWT	Z

Table B.2 Barrier Data

Barrier Materials			Plan ID	Compartment Name Adjacent Compartment	Area sq ft	Therm adj	Durab adj	Doors / Hatches	DC Rating
<1>	<2>	<3>							
S2I	S3U		(none)	(weather bulkhead)	110.2	0	0		
S4I			4-66-0-E	MAIN MACHINERY ROOM	388.4	0	0		
S4I			2-89-1-C	ENGINEERING CONTROL	155	0	0	HS	X
S4U			01-60-0A-L	PASSAGE	88	0	0		
S4U			01-60-0B-L	PASSAGE	28.8	0	0		
S4U			01-66-2-L	PASSAGE	5.6	0	0		
S4U			01-68-0-Q	SHIP OFFICE	121.6	0	0		
S4U			01-68-1-L	MEDICAL TREATMENT RO	159.2	0	0		
S4U			01-71-2-L	CPO WR, WC, SH	30	0	0		
S4U			01-74-1-L	MEDICAL TREATMENT WR	40	0	0		
S4U			01-79-0A-L	PASSAGE	24	0	0		
S4U			(none)	(weather overhead)	58	0	0		
			1-66-1-Q	GALLEY ANNEX	(CUI = QG)				
S3U		S3U	1-57-1-Q	GALLEY	133	0	0	DWT	Z
S3U		S3U	1-66-0-L	CREW MESS	57	0	0		
S3U		S3U	1-66-0-L	CREW MESS	133	0	0	2 DO	O
S3U		S3U	1-66-3-Q	SCULLERY	57	0	0	DJ	NC
S4I			4-66-0-E	MAIN MACHINERY ROOM	83.2	0	0		
S4U			01-60-0B-L	PASSAGE	50.4	0	0		
S4U			01-68-0-Q	SHIP OFFICE	14.4	0	0		
S4U			01-68-1-L	MEDICAL TREATMENT RO	19.2	0	0		
			1-66-2-L	COMPANIONWAY	(CUI = LP)				
S3U		S3U	1-57-2-L	PASSAGE	9.5	0	0		
S3U		S3U	1-60-6A-A	DRY PROVISION STORER	91.2	0	0		
S3U		S3I	1-60-6B-A	DRY PROVISION STORER	47.5	0	0		
S3U		S3U	1-66-0-L	CREW MESS	38	0	0	DJ	NC
S3U		S3U	1-66-0-L	CREW MESS	9.5	0	0		
S3U		S3U	1-66-0-L	CREW MESS	53.2	0	0		
S3U		S3U	1-66-0-L	CREW MESS	47.5	0	0		
S4I			4-66-0-E	MAIN MACHINERY ROOM	52	0	0	HL	X
								HS	Z
S4U			01-66-2-L	PASSAGE	48.6	0	0		
S4U			01-70-2-Q	C.G. LKR	3.4	0	0	HL	X
								HS	Z
			1-66-3-Q	SCULLERY	(CUI = QG)				
S3U		S3U	1-57-1-Q	GALLEY	85.5	0	0		
S3U		S3U	1-66-0-L	CREW MESS	38	0	0		
S3U		S3U	1-66-0-L	CREW MESS	85.5	0	0	DJ	NC
S3U		S3U	1-66-1-Q	GALLEY ANNEX	57	0	0	DJ	NC
S2I	S3U		(none)	(weather bulkhead)	95	0	0		
S4I			4-66-0-E	MAIN MACHINERY ROOM	50.5	0	0		
S4I			2-89-1-C	ENGINEERING CONTROL	35.6	0	0		
S4U			01-60-0B-L	PASSAGE	14.4	0	0		
S4U			01-68-1-L	MEDICAL TREATMENT RO	25.6	0	0		
S4U			(none)	(weather overhead)	50	0	0		
			1-71-2-Q	ENG LOG OFFICE & DC CENTRAL	(CUI = QO)				
S3U		S3U	1-60-6A-A	DRY PROVISION STORER	85.5	0	0		
S2U		S2U	1-66-0-L	CREW MESS	47.5	0	0	DJ	NC
S3U		S3U	1-74-2-Q	DC REPAIR LKR NO. 2	66.5	0	0		
S3U		S3U	1-77-2-L	CPO MESS & LOUNGE	85.5	0	0		
S2I	S3U		(none)	(weather bulkhead)	114	0	0		
S4I			4-66-0-E	MAIN MACHINERY ROOM	99.9	0	0		
S4U			01-71-2-L	CPO WR, WC, SH	24	0	0		
S4U			01-74-2-L	CPO SR	24	0	0		

Table B.2 Barrier Data

Barrier Materials			Plan ID	Compartment Name	Area sq ft	Therm adj	Durab adj	Doors / Hatches	DC Rating
<1>	<2>	<3>							
S4U			(none)	(weather overhead)	60	0	0		
			1-74-2-Q	DC REPAIR LKR NO. 2	(CUI = QA)				
S3U		S3U	1-66-0-L	CREW MESS	57	0	0		
S3U		S3U	1-66-0-L	CREW MESS	66.5	0	0	DJ	NC
S3U		S3U	1-71-2-Q	ENG LOG OFFICE & DC	66.5	0	0		
S3U		S3U	1-77-2-L	CPO MESS & LOUNGE	57	0	0		
S4I			4-66-0-E	MAIN MACHINERY ROOM	42	0	0		
S4U			01-71-2-L	CPO WR, WC, SH	6	0	0		
S4U			01-74-2-L	CPO SR	36	0	0		
			1-76-0-Q	MMR (UPTAKE)	(CUI = TU)				
S3U		S3U	4-82-0-E	AUXILIARY MACHINERY	76	0	0		
S3U		S3I	1-66-0-L	CREW MESS	114	0	0		
S3U		S3I	1-66-0-L	CREW MESS	76	0	0		
S3U		S3U	1-66-0-L	CREW MESS	19	0	0		
S3U		S3I	1-77-1-A	CREW LOCKER	55.1	0	0		
S3U		S3I	1-80-1-E	VENT PLENUM	39.9	0	0		
S3U		S3I	01-60-0A-L	PASSAGE	51	0	0		
S3U		S3I	01-68-0-Q	SHIP OFFICE	34	0	0		
S3U		S3I	01-74-1-L	MEDICAL TREATMENT WR	34	0	0		
S3U		S3I	01-74-1-L	MEDICAL TREATMENT WR	34	0	0		
S3U		S3U	01-78-1-F	EMERGENCY GEN SERVIC	34	0	0		
S3U		S3I	01-78-3-E	EMERGENCY GENERATOR	51	0	0		
S3U		S3I	01-79-0A-L	PASSAGE	102	0	0		
S3U		S3I	01-79-0B-L	PASSAGE	68	0	0		
S3U		S3U	1-80-1-Q	VENT PLENUM	34	0	0		
S3U		S3U	1-80-1-Q	VENT PLENUM	34	0	0		
S3U		S3U	02-73-0-Q	FAN ROOM	17	0	0		
S3U		S3U	02-73-0-Q	FAN ROOM	68	0	0		
S3U		S3I	02-73-0-Q	FAN ROOM	68	0	0		
S3U		S3I	02-85-0-Q	INCINERATOR ROOM	68	0	0		
S3U	S3U		(none)	(weather bulkhead)	51	0	0		
S3U	S3U		(none)	(weather bulkhead)	136	0	0		
000			4-66-0-E	MAIN MACHINERY ROOM	96	0	0		
S4U			4-82-0-E	AUXILIARY MACHINERY	48	0	0		
S4U			03-76-0-Q	STACK	144	0	0		
			1-77-1-A	CREW LOCKER	(CUI = AG)				
S2U		S2U	1-66-0-L	CREW MESS	38	0	0	DJ	NO
S3I		S3U	1-76-0-Q	MMR (UPTAKE)	55.1	0	0		
S2U		S2U	1-77-3-L	CREW LOUNGE	55.1	0	0		
S3I		S3U	1-80-1-E	VENT PLENUM	38	0	0		
S4I			4-66-0-E	MAIN MACHINERY ROOM	23.2	0	0		
S4U			01-74-1-L	MEDICAL TREATMENT WR	8	0	0		
S4U			01-78-1-F	EMERGENCY GEN SERVIC	15.2	0	0		
			1-77-2-L	CPO MESS & LOUNGE	(CUI = LL)				
S2U		S2U	1-66-0-L	CREW MESS	95	0	0	DJ	NC
S3U		S3U	1-71-2-Q	ENG LOG OFFICE & DC	85.5	0	0		
S3U		S3U	1-74-2-Q	DC REPAIR LKR NO. 2	57	0	0		
S3U		S3U	1-82-2-Q	C.G. LKR W/ SINK	38	0	0		
S3U		S3U	1-82-4-L	CREW WR, WC & SH	104.5	0	0		
S2I	S3U		(none)	(weather bulkhead)	95	0	0		
S4I			4-66-0-E	MAIN MACHINERY ROOM	134.5	0	0		
S4U			01-74-2-L	CPO SR	50	0	0		
S4U			01-80-0-L	CREW SR	50	0	0		
S4U			(none)	(weather overhead)	50	0	0		

Table B.2 Barrier Data

Barrier Materials			Plan ID	Compartment Name Adjacent Compartment	Area sq ft	Therm adj	Durab adj	Doors / Hatches	DC Rating
<1>	<2>	<3>							
			1-77-3-L	CREW LOUNGE	(CUI = LL)				
NPU		NSU	1-66-0-L	CREW MESS	142.5	0	0	DJ	NO
S2U		S2U	1-77-1-A	CREW LOCKER	55.1	0	0		
S3U		S3U	1-80-1-E	VENT PLENUM	39.9	0	0		
S3U		S3U	1-82-1-L	CREW WR, WC & SH	51.3	0	0		
S3U		S3U	1-82-3-L	CREW WR, WC & SH	91.2	0	0		
S2I	S3U		(none)	(weather bulkhead)	95	0	0		
S4I			4-66-0-E	MAIN MACHINERY ROOM	20	0	0		
S4I			2-89-1-C	ENGINEERING CONTROL	113.1	0	0		
S4U			01-68-1-L	MEDICAL TREATMENT RO	20	0	0		
S4U			01-78-3-E	EMERGENCY GENERATOR	80	0	0		
S4U			(none)	(weather overhead)	50	0	0		
			1-80-1-E	VENT PLENUM	(CUI = TH)				
S3I		S3U	1-76-0-Q	MMR (UPTAKE)	39.9	0	0		
S3U		S3I	1-77-1-A	CREW LOCKER	38	0	0		
S3U		S3U	1-77-3-L	CREW LOUNGE	39.9	0	0		
S3U		S3U	1-82-1-L	CREW WR, WC & SH	38	0	0		
S4I			4-66-0-E	MAIN MACHINERY ROOM	16.8	0	0		
S4U			1-80-1-Q	VENT PLENUM	16	0	0		
			1-82-0-L	PASSAGE	(CUI = LP)				
S3U		S3U	4-82-0-E	AUXILIARY MACHINERY	57	0	0		
S3U		S3U	1-66-0-L	CREW MESS	38	0	0	DWT	Z
S3U		S3U	1-82-2-Q	C.G. LKR W/ SINK	38	0	0	DJ	NC
S2U		S2U	1-84-2-L	COMPANIONWAY	114	0	0	DJ	NC
S2U		S2U	1-85-1-L	CREW SR	95	0	0	DJ	NC
000		000	1-85-2-Q	AFF STA.	95	0	0		
S2U		S2U	1-85-2-Q	AFF STA.	38	0	0		
S2U		S2U	1-85-3-L	CREW SR	38	0	0	DJ	NC
S2U		S2U	1-85-4-L	CREW SR	38	0	0	DJ	NC
S3U		S3U	1-92-0-L	PASSAGE	171	0	0	DWT	Z
S4I			4-82-0-E	AUXILIARY MACHINERY	136	0	0	HS	Z
S4U			01-79-0A-L	PASSAGE	80	0	0		
S4U			01-88-0-L	CREW SR	34.4	0	0		
S4U			01-88-1-L	CREW WR, WC & SH	21.6	0	0		
			1-82-1-L	CREW WR, WC & SH	(CUI = LW)				
S3I		S3U	4-82-0-E	AUXILIARY MACHINERY	57	0	0		
S3U		S3U	1-77-3-L	CREW LOUNGE	51.3	0	0		
S3U		S3U	1-80-1-E	VENT PLENUM	38	0	0		
S3U		S3U	1-82-3-L	CREW WR, WC & SH	57	0	0		
NPU		NPU	1-85-1-L	CREW SR	76	0	0	DJ	NO
NPU		NPU	1-85-3-L	CREW SR	13.3	0	0		
S4I			4-82-0-E	AUXILIARY MACHINERY	56.4	0	0		
S4U			01-78-3-E	EMERGENCY GENERATOR	56.4	0	0		
			1-82-2-Q	C.G. LKR W/ SINK	(CUI = AG)				
S3U		S3U	1-77-2-L	CPO MESS & LOUNGE	38	0	0		
S3U		S3U	1-82-0-L	PASSAGE	38	0	0	DJ	NC
S3U		S3U	1-82-4-L	CREW WR, WC & SH	38	0	0		
S2U		S2U	1-84-2-L	COMPANIONWAY	38	0	0		
S4I			4-82-0-E	AUXILIARY MACHINERY	16	0	0		
S4U			01-80-0-L	CREW SR	11.2	0	0		
S4U			01-84-2-L	CREW WR, WC & SH	4.8	0	0		
			1-82-3-L	CREW WR, WC & SH	(CUI = LW)				
S3U		S3U	1-77-3-L	CREW LOUNGE	91.2	0	0		
S3U		S3U	1-82-1-L	CREW WR, WC & SH	57	0	0		

Table B.2 Barrier Data

Barrier Materials			Plan ID	Compartment Name Adjacent Compartment	Area sq ft	Therm adj	Durab adj	Doors / Hatches	DC Rating
<1>	<2>	<3>							
NPU		NPU	1-85-3-L	CREW SR	91.2	0	0	DJ	NO
S2I	S3U		(none)	(weather bulkhead)	57	0	0		
S4I			4-82-0-E	AUXILIARY MACHINERY	43.8	0	0		
S4U			01-78-3-E	EMERGENCY GENERATOR	27.6	0	0		
S4U			(none)	(weather overhead)	30	0	0		
			1-82-4-L	CREW WR, WC & SH	(CUI = LW)				
S3U		S3U	1-77-2-L	CPO MESS & LOUNGE	104.5	0	0		
S3U		S3U	1-82-2-Q	C.G. LKR W/ SINK	38	0	0		
S3U		S3U	1-84-2-L	COMPANIONWAY	19	0	0		
NPU		NPU	1-85-4-L	CREW SR	104.5	0	0	DJ	NO
S2I	S3U		(none)	(weather bulkhead)	57	0	0		
S4I			4-82-0-E	AUXILIARY MACHINERY	52.2	0	0		
S4U			01-80-0-L	CREW SR	16.8	0	0		
S4U			01-84-2-L	CREW WR, WC & SH	19.2	0	0		
S4U			(none)	(weather overhead)	30	0	0		
			1-84-2-L	COMPANIONWAY	(CUI = LP)				
S2U		S2U	1-82-0-L	PASSAGE	114	0	0	DJ	NC
S2U		S2U	1-82-2-Q	C.G. LKR W/ SINK	38	0	0		
S3U		S3U	1-82-4-L	CREW WR, WC & SH	19	0	0		
S2U		S2U	1-85-4-L	CREW SR	95	0	0		
S2U		S2U	1-85-4-L	CREW SR	38	0	0		
S4I			4-82-0-E	AUXILIARY MACHINERY	48	0	0	HL	X
S4U			01-84-2-L	CREW WR, WC & SH	8	0	0		
S4U			01-85-2-Q	FOUL WEATHER GEAR LK	24	0	0		
S4U			01-88-2-L	CREW SR	16	0	0		
			1-85-1-L	CREW SR	(CUI = L5)				
S3I		S3U	4-82-0-E	AUXILIARY MACHINERY	38	0	0		
S2U		S2U	1-82-0-L	PASSAGE	95	0	0	DJ	NC
NPU		NPU	1-82-1-L	CREW WR, WC & SH	76	0	0	DJ	NO
S2U		S2U	1-85-2-Q	AFF STA.	95	0	0		
NPU		NPU	1-85-3-L	CREW SR	19	0	0		
NPU		NPU	1-85-3-L	CREW SR	95	0	0		
S4I			4-82-0-E	AUXILIARY MACHINERY	120	0	0		
S4U			01-78-3-E	EMERGENCY GENERATOR	16	0	0		
S4U			01-79-0B-L	PASSAGE	56	0	0		
S4U			01-88-0-L	CREW SR	18.4	0	0		
S4U			01-88-1-L	CREW WR, WC & SH	29.6	0	0		
			1-85-2-Q	AFF STA.	(CUI = QA)				
S2U		S2U	4-82-0-E	AUXILIARY MACHINERY	38	0	0		
000		000	1-82-0-L	PASSAGE	95	0	0		
S2U		S2U	1-82-0-L	PASSAGE	38	0	0		
S2U		S2U	1-85-1-L	CREW SR	95	0	0		
S4I			4-82-0-E	AUXILIARY MACHINERY	40	0	0		
S4U			01-79-0B-L	PASSAGE	24	0	0	HS	X
S4U			01-88-0-L	CREW SR	16	0	0		
			1-85-3-L	CREW SR	(CUI = L5)				
S2U		S2U	1-82-0-L	PASSAGE	38	0	0	DJ	NC
NPU		NPU	1-82-1-L	CREW WR, WC & SH	13.3	0	0		
NPU		NPU	1-82-3-L	CREW WR, WC & SH	91.2	0	0	DJ	NO
NPU		NPU	1-85-1-L	CREW SR	19	0	0		
NPU		NPU	1-85-1-L	CREW SR	95	0	0		
S3U		S3U	1-92-1-L	CREW SR	119.7	0	0		
S2I	S3U		(none)	(weather bulkhead)	133.1	0	0		
S4I			4-82-0-E	AUXILIARY MACHINERY	93.8	0	0		

Table B.2 Barrier Data

Barrier Materials			Plan ID	Compartment Name	Area sq ft	Therm adj	Durab adj	Doors / Hatches	DC Rating
<1>	<2>	<3>							
S4I			01-78-3-E	EMERGENCY GENERATOR	12	0	0		
S4I			01-86-1-L	CREW SR	72	0	0		
S4I			01-88-1-L	CREW WR, WC & SH	8	0	0		
S4I			(none)	(weather overhead)	67.2	0	0		
			1-85-4-L	CREW SR	(CUI = L5)				
S2U		S2U	1-82-0-L	PASSAGE	38	0	0	DJ	NC
NPU		NPU	1-82-4-L	CREW WR, WC & SH	104.5	0	0	DJ	NO
S2U		S2U	1-84-2-L	COMPANIONWAY	95	0	0		
S2U		S2U	1-84-2-L	COMPANIONWAY	38	0	0		
S3U		S3U	1-92-2-L	CREW SR	138.7	0	0		
S2I	S3U		(none)	(weather bulkhead)	133.1	0	0		
S4I			4-82-0-E	AUXILIARY MACHINERY	101.8	0	0		
S4U			01-84-2-L	CREW WR, WC & SH	36	0	0		
S4U			01-88-2-L	CREW SR	64	0	0		
S4U			(none)	(weather overhead)	67.2	0	0		
			1-92-0-L	PASSAGE	(CUI = LP)				
S3U		S3U	1-82-0-L	PASSAGE	171	0	0	DWT	Z
S2U		S2U	1-92-1-L	CREW SR	72.2	0	0	DJ	NC
S2U		S2U	1-92-2-L	CREW SR	91.2	0	0	DJ	NC
S2U		S2U	1-96-0-L	CREW SR	114	0	0		
S2U		S2U	1-96-0-L	CREW SR	104.5	0	0	DJ	NC
S2U		S2U	1-96-1-L	CREW WR, WC & SH	28.5	0	0		
S3U		S3U	1-97-2-Q	FAN ROOM	95	0	0	DJ	NC
S3I		S3U	1-102-2-A	DECK GEAR STOREROOM	38	0	0	DJ	NC
S4I			4-92-0-E	STERN THRUSTER MACHR	151	0	0	HS	X
								HS	Z
S4U			01-79-0A-L	PASSAGE	24	0	0		
S4I			01-92-0-L	COMPANIONWAY	36	0	0	HL	X
								HS	Z
S4I			(none)	(weather overhead)	124.8	0	0		
			1-92-1-L	CREW SR	(CUI = L5)				
S3U		S3U	1-85-3-L	CREW SR	119.7	0	0		
S2U		S2U	1-92-0-L	PASSAGE	72.2	0	0	DJ	NC
NPU		NPU	1-96-1-L	CREW WR, WC & SH	38	0	0		
NPU		NPU	1-96-1-L	CREW WR, WC & SH	28.5	0	0		
NPU		NPU	1-98-1-L	CREW WR, WC & SH	81.7	0	0	DJ	NO
S2I	S3U		(none)	(weather bulkhead)	110.6	0	0		
S4I			4-92-0-E	STERN THRUSTER MACHR	15	0	0		
S4U			(none)	(weather overhead)	140.4	0	0		
			1-92-2-L	CREW SR	(CUI = L5)				
S3U		S3U	1-85-4-L	CREW SR	138.7	0	0		
S2U		S2U	1-92-0-L	PASSAGE	91.2	0	0	DJ	NC
NPU		S3U	1-97-2-Q	FAN ROOM	57	0	0		
NPU		NPU	1-97-4-L	CREW WR, WC & SH	76	0	0	DJ	NO
S2I	S3U		(none)	(weather bulkhead)	91.4	0	0		
S4I			4-92-0-E	STERN THRUSTER MACHR	29.7	0	0		
S4I			(none)	(weather overhead)	137.3	0	0		
			1-96-0-L	CREW SR	(CUI = L5)				
S2U		S2U	1-92-0-L	PASSAGE	114	0	0		
S2U		S2U	1-92-0-L	PASSAGE	104.5	0	0	DJ	NC
NPU		NPU	1-96-1-L	CREW WR, WC & SH	114	0	0	DJ	NO
S3I		S3U	1-102-0-E	STEERING GEAR ROOM	104.5	0	0		
S4I			4-92-0-E	STERN THRUSTER MACHR	76	0	0		
S4I			(none)	(weather overhead)	132	0	0		

Table B.2 Barrier Data

Barrier Materials			Plan ID	Compartment Name Adjacent Compartment	Area sq ft	Therm adj	Durab adj	Doors / Hatches	DC Rating
<1>	<2>	<3>							
			1-96-1-L	CREW WR, WC & SH	(CUI = LW)				
S2U		S2U	1-92-0-L	PASSAGE	28.5	0	0		
NPU		NPU	1-92-1-L	CREW SR	38	0	0		
NPU		NPU	1-92-1-L	CREW SR	28.5	0	0		
NPU		NPU	1-96-0-L	CREW SR	114	0	0	DJ	NO
NPU		NPU	1-98-1-L	CREW WR, WC & SH	76	0	0		
S3I		S3U	1-102-0-E	STEERING GEAR ROOM	57	0	0		
S4I			4-92-0-E	STERN THRUSTER MACHR	2.3	0	0		
S4I			(none)	(weather overhead)	60	0	0		
			1-97-2-Q	FAN ROOM	(CUI = QF)				
S3U		S3U	1-92-0-L	PASSAGE	95	0	0	DJ	NC
S3U		NPU	1-92-2-L	CREW SR	57	0	0		
S3U		NPI	1-97-4-L	CREW WR, WC & SH	95	0	0		
S3U		S3U	1-102-2-A	DECK GEAR STOREROOM	57	0	0		
S4I			(none)	(weather overhead)	60	0	0		
			1-97-4-L	CREW WR, WC & SH	(CUI = LW)				
NPU		NPU	1-92-2-L	CREW SR	76	0	0	DJ	NO
NPI		S3U	1-97-2-Q	FAN ROOM	95	0	0		
NPI		S3U	1-102-2-A	DECK GEAR STOREROOM	57	0	0		
S2I	S3U		(none)	(weather bulkhead)	96.9	0	0		
S4I			(none)	(weather overhead)	70	0	0		
			1-98-1-L	CREW WR, WC & SH	(CUI = LW)				
NPU		NPU	1-92-1-L	CREW SR	81.7	0	0	DJ	NO
NPU		NPU	1-96-1-L	CREW WR, WC & SH	76	0	0		
S3I		S3U	1-102-0-E	STEERING GEAR ROOM	66.5	0	0		
S2I	S3U		(none)	(weather bulkhead)	77.5	0	0		
S4I			(none)	(weather overhead)	62.4	0	0		
			1-102-0-E	STEERING GEAR ROOM	(CUI = EM)				
S3U		S3I	1-96-0-L	CREW SR	104.5	0	0		
S3U		S3I	1-96-1-L	CREW WR, WC & SH	57	0	0		
S3U		S3I	1-98-1-L	CREW WR, WC & SH	66.5	0	0		
S3U		S3U	1-102-2-A	DECK GEAR STOREROOM	57	0	0	DJ	NC
S3U		S3U	1-105-2-Q	LAUNDRY	95	0	0		
S2U	S3U		(none)	(weather bulkhead)	142.5	0	0		
S2U	S3U		(none)	(weather bulkhead)	113.8	0	0		
S2U	S3U		(none)	(weather bulkhead)	61.4	0	0		
S4U			(none)	(weather overhead)	319.8	0	0		
			1-102-2-A	DECK GEAR STOREROOM	(CUI = AS)				
S3U		S3I	1-92-0-L	PASSAGE	38	0	0	DJ	NC
S3U		S3U	1-97-2-Q	FAN ROOM	57	0	0		
S3U		NPI	1-97-4-L	CREW WR, WC & SH	57	0	0		
S3U		S3U	1-102-0-E	STEERING GEAR ROOM	57	0	0	DJ	NC
S3U		S3U	1-105-2-Q	LAUNDRY	129.2	0	0	DJ	NC
S2I	S3U		(none)	(weather bulkhead)	61.4	0	0		
S4I			(none)	(weather overhead)	88.8	0	0	HS	X
			1-105-2-Q	LAUNDRY	(CUI = QL)				
S3U		S3U	1-102-0-E	STEERING GEAR ROOM	95	0	0		
S3U		S3U	1-102-2-A	DECK GEAR STOREROOM	129.2	0	0	DJ	NC
S2I	S3U		(none)	(weather bulkhead)	66.5	0	0		
S2I	S3U		(none)	(weather bulkhead)	113.8	0	0		
S4I			(none)	(weather overhead)	103	0	0		
			01-27-0-C	BUOY DECK CONTROL BOOTH	(CUI = C)				
S3U	S3U		(none)	(weather bulkhead)	54.4	0	0		
S3U	S3U		(none)	(weather bulkhead)	51	0	0		

Table B.2 Barrier Data

Barrier Materials			Plan ID	Compartment Name	Area sq ft	Therm adj	Durab adj	Doors / Hatches	DC Rating
<1>	<2>	<3>							
S3U	S3U		(none)	(weather bulkhead)	54.4	0	0	DJ	NC
S3U	S3U		(none)	(weather bulkhead)	51	0	0		
S4U			3-23-0-Q	CRANE PEDESTAL	12.8	0	0		
S4U			(none)	(weather overhead)	38.4	0	0		
			01-57-0-Q	WARD ROOM PANTRY	(CUI = QG)				
S3I	S3U		1-57-3-Q	DUMBWAITER TRUNK	25.5	0	0		
S3I	S3U		1-57-3-Q	DUMBWAITER TRUNK	25.5	0	0		
S3I	S3U		1-57-3-Q	DUMBWAITER TRUNK	25.5	0	0		
S3U	S3U		01-57-2-L	CPO SR	51	0	0		
S3U	S3U		01-60-0C-L	PASSAGE	17	0	0		
S3U	S3U		01-60-1-L	WARDROOM MESSROOM &	153	0	0	DJ	NC
S3I	S3U		(none)	(weather bulkhead)	51	0	0		
S3I	S3U		(none)	(weather bulkhead)	59.5	0	0		
S3I	S3U		(none)	(weather bulkhead)	85	0	0		
S4U			1-57-0-L	DECK WR & WC	32	0	0		
S4U			1-57-1-Q	GALLEY	75	0	0		
S4U			1-59-2-L	COMPANIONWAY	4	0	0		
S4U			02-57-0-L	CO CABIN	71	0	0		
S4U			02-57-1-L	CO SR	36	0	0		
S4U			02-59-2-L	COMPANIONWAY	4	0	0		
			01-57-2-L	CPO SR	(CUI = L2)				
S3U	S3U		01-57-0-Q	WARD ROOM PANTRY	51	0	0		
NPU	NPU		01-57-4-L	CPO WR, WC, SH	86.7	0	0	DJ	NO
S2U	S2U		01-60-0C-L	PASSAGE	35.7	0	0	DJ	NC
S3U	S3U		01-60-0C-L	PASSAGE	34	0	0		
NPU	NPU		01-83-2-L	CPO SR	51	0	0		
S3I	S3U		(none)	(weather bulkhead)	85	0	0		
S4U			1-57-0-L	DECK WR & WC	8	0	0		
S4U			1-57-2-L	PASSAGE	42.6	0	0		
S4U			1-57-4-Q	CHANGE ROOM	18	0	0		
S4U			1-59-2-L	COMPANIONWAY	4	0	0		
S4U			1-60-2-A	CHILL STRM	12.6	0	0		
S4U			02-57-0-L	CO CABIN	8	0	0		
S4U			02-57-0C-L	PASSAGE	32.4	0	0		
S4U			02-57-2-L	XO WR, WC, SH	24	0	0		
S4U			02-57-4-L	XO SR	16.8	0	0		
S4U			02-59-2-L	COMPANIONWAY	4	0	0		
			01-57-4-L	CPO WR, WC, SH	(CUI = LW)				
NPU	NPU		01-57-2-L	CPO SR	86.7	0	0	DJ	NO
NPU	NPU		01-83-2-L	CPO SR	51	0	0	DJ	NO
S3I	S3U		(none)	(weather bulkhead)	51	0	0		
S3I	S3U		(none)	(weather bulkhead)	86.7	0	0		
S4U			1-57-4-Q	CHANGE ROOM	36	0	0		
S4U			1-60-2-A	CHILL STRM	12.6	0	0		
S4U			1-60-4-A	FREEZE STRM	12.6	0	0		
S4U			02-57-2-L	XO WR, WC, SH	15.6	0	0		
S4U			02-57-4-L	XO SR	45.6	0	0		
			01-60-0A-L	PASSAGE	(CUI = LP)				
S3I	S3U		1-76-0-Q	MMR (UPTAKE)	51	0	0		
000	000		01-60-0B-L	PASSAGE	34	0	0		
S2U	S2U		01-66-2-L	PASSAGE	51	0	0		
S2U	S2U		01-68-0-Q	SHIP OFFICE	136	0	0		
S2U	S2U		01-71-2-L	CPO WR, WC, SH	51	0	0		
S2U	S2U		01-74-2-L	CPO SR	85	0	0	DJ	NC

Table B.2 Barrier Data

Barrier Materials			Plan ID	Compartment Name Adjacent Compartment	Area sq ft	Therm adj	Durab adj	Doors / Hatches	DC Rating
<1>	<2>	<3>							
NPU		NPU	01-79-0A-L	PASSAGE	34	0	0	DJ	NO
S4U			1-66-0-L	CREW MESS	88	0	0		
S4U			02-57-0A-L	PASSAGE	16	0	0		
S4U			02-57-0C-L	PASSAGE	24	0	0		
S4U			02-73-0-Q	FAN ROOM	32	0	0		
S4U			(none)	(weather overhead)	16	0	0		
			01-60-0B-L	PASSAGE	(CUI = LP)				
000		000	01-60-0A-L	PASSAGE	34	0	0		
000		000	01-60-0C-L	PASSAGE	51	0	0		
S2U		S2U	01-60-1-L	WARDROOM MESSROOM &	153	0	0	DJ	NC
S2U		S2U	01-66-2-L	PASSAGE	30.6	0	0	DJ	NC
S2U		S2U	01-68-0-Q	SHIP OFFICE	85	0	0	DJ	NC
S2U		NSU	01-68-1-L	MEDICAL TREATMENT RO	102	0	0	DJ	NC
S2U		S2U	01-83-2-L	CPO SR	17	0	0		
S3I	S3U		(none)	(weather bulkhead)	30.6	0	0	DWT	Z
S4U			1-66-0-L	CREW MESS	28.8	0	0		
S4U			1-66-1-Q	GALLEY ANNEX	50.4	0	0		
S4U			1-66-3-Q	SCULLERY	14.4	0	0		
S4U			02-57-0C-L	PASSAGE	14.4	0	0		
S4U			02-61-2-L	COMPANIONWAY	8	0	0		
S4U			02-66-0-C	RADIO ROOM	49.6	0	0		
S4U			02-66-1-L	OFFICER WR, WC, SH	21.6	0	0		
			01-60-0C-L	PASSAGE	(CUI = LP)				
S3U		S3U	01-57-0-Q	WARD ROOM PANTRY	17	0	0		
S2U		S2U	01-57-2-L	CPO SR	35.7	0	0	DJ	NC
S3U		S3U	01-57-2-L	CPO SR	34	0	0		
000		000	01-60-0B-L	PASSAGE	51	0	0		
S2U		S2U	01-60-1-L	WARDROOM MESSROOM &	102	0	0		
S2U		S2U	01-83-2-L	CPO SR	66.3	0	0	DJ	NC
S4U			1-57-2-L	PASSAGE	40	0	0		
S4U			1-59-2-L	COMPANIONWAY	32	0	0		
S4U			02-57-0C-L	PASSAGE	24	0	0		
S4U			02-59-2-L	COMPANIONWAY	8	0	0		
S4U			02-61-2-L	COMPANIONWAY	40	0	0	HO	O
			01-60-1-L	WARDROOM MESSROOM & LOUNGE	(CUI = LL)				
S3U		S3U	01-57-0-Q	WARD ROOM PANTRY	153	0	0	DJ	NC
S2U		S2U	01-60-0B-L	PASSAGE	153	0	0	DJ	NC
S2U		S2U	01-60-0C-L	PASSAGE	102	0	0		
S3I	S3U		(none)	(weather bulkhead)	102	0	0		
S4U			1-57-1-Q	GALLEY	184	0	0		
S4U			1-60-1-L	GALLEY WR & WC	32	0	0		
S4U			02-57-0-L	CO CABIN	144	0	0		
S4U			02-57-1-L	CO SR	36	0	0		
S4U			02-63-1-L	CO WR, WC, SH	36	0	0		
			01-66-2-L	PASSAGE	(CUI = LP)				
S2U		S2U	01-60-0A-L	PASSAGE	51	0	0		
S2U		S2U	01-60-0B-L	PASSAGE	30.6	0	0	DJ	NC
S2U		S2U	01-70-2-Q	C.G. LKR	42.5	0	0	DJ	NC
S2U		S2U	01-70-2-Q	C.G. LKR	28.9	0	0		
S2U		S2U	01-71-2-L	CPO WR, WC, SH	42.5	0	0		
S2U		S2U	01-83-2-L	CPO SR	85	0	0		
S3I	S3U		(none)	(weather bulkhead)	52.7	0	0	DWT	Z
S4U			1-60-6A-A	DRY PROVISION STORER	24.8	0	0		
S4U			1-66-0-L	CREW MESS	5.6	0	0		

Table B.2 Barrier Data

Barrier Materials			Plan ID	Compartment Name Adjacent Compartment	Area sq ft	Therm adj	Durab adj	Doors / Hatches	DC Rating
<1>	<2>	<3>							
S4U			1-66-2-L	COMPANIONWAY	48.6	0	0		
S4U			02-66-2-L	OFFICER WR, WC, SH	37	0	0		
S4U			02-66-4-L	OFFICER WR, WC, SH	19	0	0		
S4U			02-69-2-Q	CG LKR W/SINK	16	0	0		
S4U			02-69-4-L	OFFICER SR	7	0	0		
			01-68-0-Q	SHIP OFFICE	(CUI = QO)				
S3I		S3U	1-76-0-Q	MMR (UPTAKE)	34	0	0		
S2U		S2U	01-60-0A-L	PASSAGE	136	0	0		
S2U		S2U	01-60-0B-L	PASSAGE	85	0	0	DJ	NC
NSU		NPU	01-68-1-L	MEDICAL TREATMENT RO	102	0	0		
NPU		NPU	01-74-1-L	MEDICAL TREATMENT WR	34	0	0		
S3U		S3U	01-74-1-L	MEDICAL TREATMENT WR	51	0	0		
S4U			1-66-0-L	CREW MESS	121.6	0	0		
S4U			1-66-1-Q	GALLEY ANNEX	14.4	0	0		
S4U			02-57-0A-L	PASSAGE	40	0	0		
S4U			02-66-0-C	RADIO ROOM	60	0	0		
S4U			02-73-0-Q	FAN ROOM	36	0	0		
			01-68-1-L	MEDICAL TREATMENT ROOM	(CUI = LM)				
NSU		S2U	01-60-0B-L	PASSAGE	102	0	0	DJ	NC
NPU		NSU	01-68-0-Q	SHIP OFFICE	102	0	0		
NPU		NPU	01-74-1-L	MEDICAL TREATMENT WR	17	0	0		
NSU		NPU	01-74-1-L	MEDICAL TREATMENT WR	68	0	0	DJ	NO
S3U		S3I	01-78-3-E	EMERGENCY GENERATOR	85	0	0		
NSU	S3U		(none)	(weather bulkhead)	170	0	0		
S4U			1-66-0-L	CREW MESS	159.2	0	0		
S4U			1-66-1-Q	GALLEY ANNEX	19.2	0	0		
S4U			1-66-3-Q	SCULLERY	25.6	0	0		
S4U			1-77-3-L	CREW LOUNGE	20	0	0		
S4U			02-57-0A-L	PASSAGE	24	0	0		
S4U			02-57-0B-L	PASSAGE	32	0	0		
S4U			02-66-0-C	RADIO ROOM	36	0	0		
S4U			02-66-1-L	OFFICER WR, WC, SH	12	0	0		
S4U			02-69-1-L	OFFICER SR	72	0	0		
S4U			02-73-0-Q	FAN ROOM	4	0	0		
S4U			02-75-1-Q	PFD & SURVIVAL SUIT	24	0	0		
S4U			(none)	(weather overhead)	20	0	0		
			01-70-2-Q	C.G. LKR	(CUI = AG)				
S2U		S2U	01-66-2-L	PASSAGE	42.5	0	0	DJ	NC
S2U		S2U	01-66-2-L	PASSAGE	28.9	0	0		
S2U		S2U	01-71-2-L	CPO WR, WC, SH	42.5	0	0		
S3I	S3U		(none)	(weather bulkhead)	28.9	0	0		
S4U			1-60-6A-A	DRY PROVISION STORER	13.6	0	0		
S4U			1-66-2-L	COMPANIONWAY	3.4	0	0	HL	X
								HS	Z
S4U			02-69-4-L	OFFICER SR	17	0	0		
			01-71-2-L	CPO WR, WC, SH	(CUI = LW)				
S2U		S2U	01-60-0A-L	PASSAGE	51	0	0		
S2U		S2U	01-66-2-L	PASSAGE	42.5	0	0		
S2U		S2U	01-70-2-Q	C.G. LKR	42.5	0	0		
NPU		NPU	01-74-2-L	CPO SR	85	0	0	DJ	NO
S3I	S3U		(none)	(weather bulkhead)	51	0	0		
S4U			1-66-0-L	CREW MESS	30	0	0		
S4U			1-71-2-Q	ENG LOG OFFICE & DC	24	0	0		
S4U			1-74-2-Q	DC REPAIR LKR NO. 2	6	0	0		

Table B.2 Barrier Data

Barrier Materials			Plan ID	Compartment Name Adjacent Compartment	Area sq ft	Therm adj	Durab adj	Doors / Hatches	DC Rating
<1>	<2>	<3>							
S4U			02-57-0A-L	PASSAGE	16	0	0		
S4U			02-69-4-L	OFFICER SR	36	0	0		
S4U			02-73-0-Q	FAN ROOM	8	0	0		
			01-74-1-L	MEDICAL TREATMENT WR, WC & SH	(CUI = LW)				
S3I	S3U		1-76-0-Q	MMR (UPTAKE)	34	0	0		
S3I	S3U		1-76-0-Q	MMR (UPTAKE)	34	0	0		
NPU	NPU		01-68-0-Q	SHIP OFFICE	34	0	0		
S3U	S3U		01-68-0-Q	SHIP OFFICE	51	0	0		
NPU	NPU		01-68-1-L	MEDICAL TREATMENT RO	17	0	0		
NPU	NSU		01-68-1-L	MEDICAL TREATMENT RO	68	0	0	DJ	NO
S3I	S3U		01-78-1-F	EMERGENCY GEN SERVIC	34	0	0		
S4U			1-66-0-L	CREW MESS	40	0	0		
S4U			1-77-1-A	CREW LOCKER	8	0	0		
S4U			02-73-0-Q	FAN ROOM	48	0	0		
			01-74-2-L	CPO SR	(CUI = L2)				
S2U	S2U		01-60-0A-L	PASSAGE	85	0	0	DJ	NC
NPU	NPU		01-71-2-L	CPO WR, WC, SH	85	0	0	DJ	NO
S3U	S3U		01-79-0A-L	PASSAGE	8.5	0	0		
NPU	NPU		01-80-0-L	CREW SR	85	0	0		
S3I	S3U		(none)	(weather bulkhead)	93.5	0	0		
S4U			1-71-2-Q	ENG LOG OFFICE & DC	24	0	0		
S4U			1-74-2-Q	DC REPAIR LKR NO. 2	36	0	0		
S4U			1-77-2-L	CPO MESS & LOUNGE	50	0	0		
S4I			02-69-4-L	OFFICER SR	12	0	0		
S4I			02-73-0-Q	FAN ROOM	24	0	0		
S4I			02-75-2-Q	PFD & SURVIVAL SUIT	24	0	0		
S4I			(none)	(weather overhead)	50	0	0		
			01-78-1-F	EMERGENCY GEN SERVICE TK	(CUI = QE)				
S3U	S3U		1-76-0-Q	MMR (UPTAKE)	34	0	0		
S3U	S3I		01-74-1-L	MEDICAL TREATMENT WR	34	0	0		
S3U	S3I		01-78-3-E	EMERGENCY GENERATOR	34	0	0		
S3U	S3U		1-80-1-Q	VENT PLENUM	34	0	0		
S4U			1-77-1-A	CREW LOCKER	15.2	0	0		
S4U			02-73-0-Q	FAN ROOM	16	0	0		
			01-78-3-E	EMERGENCY GENERATOR ROOM	(CUI = QE)				
S3I	S3U		1-76-0-Q	MMR (UPTAKE)	51	0	0		
S3I	S3U		01-68-1-L	MEDICAL TREATMENT RO	85	0	0		
S3I	S3U		01-78-1-F	EMERGENCY GEN SERVIC	34	0	0		
S3I	S3U		01-79-0B-L	PASSAGE	17	0	0		
S3I	S3U		01-79-0B-L	PASSAGE	68	0	0	DJ	NC
S3I	S3U		1-80-1-Q	VENT PLENUM	34	0	0		
S3I	S3U		1-80-1-Q	VENT PLENUM	34	0	0		
S3I	S3U		01-86-1-L	CREW SR	51	0	0		
S3I	S3U		(none)	(weather bulkhead)	136	0	0		
S4U			1-77-3-L	CREW LOUNGE	80	0	0		
S4U			1-82-1-L	CREW WR, WC & SH	56.4	0	0		
S4U			1-82-3-L	CREW WR, WC & SH	27.6	0	0		
S4U			1-85-1-L	CREW SR	16	0	0		
S4I			1-85-3-L	CREW SR	12	0	0		
S4I			02-85-0-Q	INCINERATOR ROOM	4	0	0		
S4I			(none)	(weather overhead)	188	0	0		
			01-79-0A-L	PASSAGE	(CUI = LP)				
S3I	S3U		1-76-0-Q	MMR (UPTAKE)	102	0	0		
NPU	NPU		01-60-0A-L	PASSAGE	34	0	0	DJ	NO

Table B.2 Barrier Data

Barrier Materials			Plan ID	Compartment Name Adjacent Compartment	Area sq ft	Therm adj	Durab adj	Doors / Hatches	DC Rating
<1>	<2>	<3>							
S3U		S3U	01-74-2-L	CPO SR	8.5	0	0		
000		000	01-79-0B-L	PASSAGE	51	0	0		
S2U		S2U	01-80-0-L	CREW SR	66.3	0	0	DJ	NC
S2U		S2U	01-84-2-L	CREW WR, WC & SH	27.2	0	0		
S2U		S2U	01-85-2-Q	FOUL WEATHER GEAR LK	51	0	0	DJ	NC
S2U		S2U	01-88-0-L	CREW SR	68	0	0		
S3U		S3U	01-88-0-L	CREW SR	17	0	0		
S2U		S2U	01-88-2-L	CREW SR	68	0	0	DJ	NC
S2U		S2U	01-92-0-L	COMPANIONWAY	34	0	0	DJ	NC
S3I	S3U		(none)	(weather bulkhead)	51	0	0		
S3I	S3U		(none)	(weather bulkhead)	34	0	0	DWT	Z
S4U			1-66-0-L	CREW MESS	24	0	0		
S4U			1-82-0-L	PASSAGE	80	0	0		
S4U			1-92-0-L	PASSAGE	24	0	0		
S4I			02-85-0-Q	INCINERATOR ROOM	16	0	0		
S4I			(none)	(weather overhead)	112	0	0		
			01-79-0B-L	PASSAGE	(CUI = LP)				
S3I	S3U		1-76-0-Q	MMR (UPTAKE)	68	0	0		
S3U	S3I		01-78-3-E	EMERGENCY GENERATOR	17	0	0		
S3U	S3I		01-78-3-E	EMERGENCY GENERATOR	68	0	0	DJ	NC
000		000	01-79-0A-L	PASSAGE	51	0	0		
S2U		S2U	01-86-1-L	CREW SR	34	0	0	DJ	NC
S2U		S2U	01-88-0-L	CREW SR	73.1	0	0	DJ	NC
S2U		S2U	01-88-1-L	CREW WR, WC & SH	62.9	0	0		
S4U			1-85-1-L	CREW SR	56	0	0		
S4U			1-85-2-Q	AFF STA.	24	0	0	HS	X
S4I			02-85-0-Q	INCINERATOR ROOM	56	0	0		
S4I			(none)	(weather overhead)	24	0	0		
			01-80-0-L	CREW SR	(CUI = L2)				
NPU		NPU	01-74-2-L	CPO SR	85	0	0		
S2U		S2U	01-79-0A-L	PASSAGE	66.3	0	0	DJ	NC
S3U		S3U	01-84-2-L	CREW WR, WC & SH	85	0	0	DJ	NO
S3I	S3U		(none)	(weather bulkhead)	66.3	0	0		
S4U			1-77-2-L	CPO MESS & LOUNGE	50	0	0		
S4U			1-82-2-Q	C.G. LKR W/ SINK	11.2	0	0		
S4U			1-82-4-L	CREW WR, WC & SH	16.8	0	0		
S4I			(none)	(weather overhead)	78	0	0		
			1-80-1-Q	VENT PLENUM	(CUI = TH)				
S3U	S3U		1-76-0-Q	MMR (UPTAKE)	34	0	0		
S3U	S3U		1-76-0-Q	MMR (UPTAKE)	34	0	0		
S3U	S3U		01-78-1-F	EMERGENCY GEN SERVIC	34	0	0		
S3U	S3I		01-78-3-E	EMERGENCY GENERATOR	34	0	0		
S3U	S3I		01-78-3-E	EMERGENCY GENERATOR	34	0	0		
S3U	S3I		02-73-0-Q	FAN ROOM	34	0	0		
S3U	S3U		(none)	(weather bulkhead)	34	0	0		
S3U	S3U		(none)	(weather bulkhead)	34	0	0		
S4U			1-80-1-E	VENT PLENUM	16	0	0		
S4U			03-76-0-Q	STACK	8	0	0		
S4U			(none)	(weather overhead)	8	0	0		
			01-83-2-L	CPO SR	(CUI = L2)				
NPU		NPU	01-57-2-L	CPO SR	51	0	0		
NPU		NPU	01-57-4-L	CPO WR, WC, SH	51	0	0	DJ	NO
S2U		S2U	01-60-0B-L	PASSAGE	17	0	0		
S2U		S2U	01-60-0C-L	PASSAGE	66.3	0	0	DJ	NC

Table B.2 Barrier Data

Barrier Materials			Plan ID	Compartment Name Adjacent Compartment	Area sq ft	Therm adj	Durab adj	Doors / Hatches	DC Rating
<1>	<2>	<3>							
S2U		S2U	01-66-2-L	PASSAGE	85	0	0		
S3I	S3U		(none)	(weather bulkhead)	66.3	0	0		
S4U			1-57-2-L	PASSAGE	23.4	0	0		
S4U			1-60-2-A	CHILL STRM	20.4	0	0		
S4U			1-60-4-A	FREEZE STRM	10.2	0	0		
S4U			1-60-6B-A	DRY PROVISION STORER	39.6	0	0		
S4U			02-57-0C-L	PASSAGE	15.6	0	0		
S4U			02-63-2-L	OFFICER SR	78	0	0		
			01-84-2-L	CREW WR, WC & SH	(CUI = LW)				
S2U		S2U	01-79-0A-L	PASSAGE	27.2	0	0		
S3U		S3U	01-80-0-L	CREW SR	85	0	0	DJ	NO
S2U		S2U	01-85-2-Q	FOUL WEATHER GEAR LK	51	0	0		
S2U		S2U	01-85-2-Q	FOUL WEATHER GEAR LK	34	0	0		
S2U		S2U	01-88-2-L	CREW SR	51	0	0	DJ	NC
S3I	S3U		(none)	(weather bulkhead)	78.2	0	0		
S4U			1-82-2-Q	C.G. LKR W/ SINK	4.8	0	0		
S4U			1-82-4-L	CREW WR, WC & SH	19.2	0	0		
S4U			1-84-2-L	COMPANIONWAY	8	0	0		
S4U			1-85-4-L	CREW SR	36	0	0		
S4I			(none)	(weather overhead)	68	0	0		
			01-85-2-Q	FOUL WEATHER GEAR LKR	(CUI = AG)				
S2U		S2U	01-79-0A-L	PASSAGE	51	0	0	DJ	NC
S2U		S2U	01-84-2-L	CREW WR, WC & SH	51	0	0		
S2U		S2U	01-84-2-L	CREW WR, WC & SH	34	0	0		
S3U		S3U	01-88-2-L	CREW SR	34	0	0		
S4U			1-84-2-L	COMPANIONWAY	24	0	0		
S4I			(none)	(weather overhead)	24	0	0		
			01-86-1-L	CREW SR	(CUI = L2)				
S3U		S3I	01-78-3-E	EMERGENCY GENERATOR	51	0	0		
S2U		S2U	01-79-0B-L	PASSAGE	34	0	0	DJ	NC
NPU		NPU	01-88-1-L	CREW WR, WC & SH	68	0	0	DJ	NC
NPI	S3U		(none)	(weather bulkhead)	51	0	0		
S3I	S3U		(none)	(weather bulkhead)	102	0	0		
S4I			1-85-3-L	CREW SR	72	0	0		
S4I			(none)	(weather overhead)	72	0	0		
			01-88-0-L	CREW SR	(CUI = L2)				
S2U		S2U	01-79-0A-L	PASSAGE	68	0	0		
S3U		S3U	01-79-0A-L	PASSAGE	17	0	0		
S2U		S2U	01-79-0B-L	PASSAGE	73.1	0	0	DJ	NC
NPU		NPU	01-88-1-L	CREW WR, WC & SH	68	0	0	DJ	NO
S3U		S3U	01-92-0-L	COMPANIONWAY	56.1	0	0		
S4U			1-82-0-L	PASSAGE	34.4	0	0		
S4U			1-85-1-L	CREW SR	18.4	0	0		
S4U			1-85-2-Q	AFFF STA.	16	0	0		
S4I			02-85-0-Q	INCINERATOR ROOM	17.2	0	0		
S4I			(none)	(weather overhead)	51.6	0	0		
			01-88-1-L	CREW WR, WC & SH	(CUI = LW)				
S2U		S2U	01-79-0B-L	PASSAGE	62.9	0	0		
NPU		NPU	01-86-1-L	CREW SR	68	0	0	DJ	NC
NPU		NPU	01-88-0-L	CREW SR	68	0	0	DJ	NO
S3U		S3U	01-92-0-L	COMPANIONWAY	20.4	0	0		
NPI	S3U		(none)	(weather bulkhead)	42.5	0	0		
S4U			1-82-0-L	PASSAGE	21.6	0	0		
S4U			1-85-1-L	CREW SR	29.6	0	0		

Table B.2 Barrier Data

Barrier Materials			Plan ID	Compartment Name Adjacent Compartment	Area sq ft	Therm adj	Durab adj	Doors / Hatches	DC Rating
<1>	<2>	<3>							
S4I			1-85-3-L	CREW SR	8	0	0		
S4I			02-85-0-Q	INCINERATOR ROOM	2.8	0	0		
S4I			(none)	(weather overhead)	56.4	0	0		
			01-88-2-L	CREW SR	(CUI = L2)				
S2U		S2U	01-79-0A-L	PASSAGE	68	0	0	DJ	NC
S2U		S2U	01-84-2-L	CREW WR, WC & SH	51	0	0	DJ	NC
S3U		S3U	01-85-2-Q	FOUL WEATHER GEAR LK	34	0	0		
S3I	S3U		(none)	(weather bulkhead)	85	0	0		
S3I	S3U		(none)	(weather bulkhead)	68	0	0		
S4U			1-84-2-L	COMPANIONWAY	16	0	0		
S4U			1-85-4-L	CREW SR	64	0	0		
S4I			(none)	(weather overhead)	80	0	0		
			01-92-0-L	COMPANIONWAY	(CUI = LP)				
S2U		S2U	01-79-0A-L	PASSAGE	34	0	0	DJ	NC
S3U		S3U	01-88-0-L	CREW SR	56.1	0	0		
S3U		S3U	01-88-1-L	CREW WR, WC & SH	20.4	0	0		
S3I	S3U		(none)	(weather bulkhead)	76.5	0	0		
S3I	S3U		(none)	(weather bulkhead)	34	0	0		
S4I			1-92-0-L	PASSAGE	36	0	0	HL	X
								HS	Z
S4U			(none)	(weather overhead)	36	0	0		
			02-57-0-L	CO CABIN	(CUI = L1)				
S2U		S2U	02-57-0C-L	PASSAGE	34	0	0	DJ	NC
NPU		NPU	02-57-1-L	CO SR	102	0	0	DJ	NO
S2U		S2U	02-59-2-L	COMPANIONWAY	34	0	0		
S2U		S2U	02-59-2-L	COMPANIONWAY	34	0	0		
S2U		S2U	02-61-2-L	COMPANIONWAY	85	0	0		
NPU		NPU	02-63-1-L	CO WR, WC, SH	51	0	0		
S3U		S3I	02-66-0-C	RADIO ROOM	102	0	0		
S3I	S3U		(none)	(weather bulkhead)	136	0	0		
S4U			1-57-3-Q	DUMBWAITER TRUNK	9	0	0		
S4U			01-57-0-Q	WARD ROOM PANTRY	71	0	0		
S4U			01-57-2-L	CPO SR	8	0	0		
S4U			01-60-1-L	WARDROOM MESSROOM &	144	0	0		
S4U			03-56-0A-C	PILOT HOUSE	229.3	0	0		
S4U			03-56-0B-C	PILOT HOUSE (CHART A	2.7	0	0		
			02-57-0A-L	PASSAGE	(CUI = LP)				
000		000	02-57-0B-L	PASSAGE	34	0	0		
000		000	02-57-0C-L	PASSAGE	34	0	0		
S3U		S3U	02-66-0-C	RADIO ROOM	136	0	0		
S2U		S2U	02-69-1-L	OFFICER SR	34	0	0		
S2U		S2U	02-69-2-Q	CG LKR W/SINK	34	0	0		
S3U		S3U	02-69-4-L	OFFICER SR	34	0	0	DJ	NC
S3U		S3U	02-73-0-Q	FAN ROOM	170	0	0		
S4U			01-60-0A-L	PASSAGE	16	0	0		
S4U			01-68-0-Q	SHIP OFFICE	40	0	0		
S4U			01-68-1-L	MEDICAL TREATMENT RO	24	0	0		
S4U			01-71-2-L	CPO WR, WC, SH	16	0	0		
S4I			03-56-0A-C	PILOT HOUSE	16	0	0		
S4I			03-56-0B-C	PILOT HOUSE (CHART A	40	0	0		
S4I			03-66-01-C	ELEX, IC & GYRO ROOM	40	0	0		
			02-57-0B-L	PASSAGE	(CUI = LP)				
000		000	02-57-0A-L	PASSAGE	34	0	0		
S2U		S2U	02-69-1-L	OFFICER SR	34	0	0	DJ	NC

Table B.2 Barrier Data

Barrier Materials			Plan ID	Compartment Name Adjacent Compartment	Area sq ft	Therm adj	Durab adj	Doors / Hatches	DC Rating
<1>	<2>	<3>							
S3U		S3U	02-73-0-Q	FAN ROOM	68	0	0	DJ	NC
S3U		S3U	02-75-1-Q	PFD & SURVIVAL SUIT	34	0	0		
S3I	S3U		(none)	(weather bulkhead)	34	0	0	DWT	Z
S4U			01-68-1-L	MEDICAL TREATMENT RO	32	0	0		
S4U			(none)	(weather overhead)	32	0	0		
			02-57-0C-L	PASSAGE	(CUI = LP)				
S2U		S2U	02-57-0-L	CO CABIN	34	0	0	DJ	NC
000		000	02-57-0A-L	PASSAGE	34	0	0		
S2U		S2U	02-57-2-L	XO WR, WC, SH	51	0	0		
S2U		S2U	02-57-4-L	XO SR	35.7	0	0	DJ	NC
S2U		S2U	02-59-2-L	COMPANIONWAY	34	0	0		
S2U		S2U	02-61-2-L	COMPANIONWAY	102	0	0	DJ	NC
S2U		S2U	02-63-2-L	OFFICER SR	66.3	0	0	DJ	NC
S3U		S3U	02-66-0-C	RADIO ROOM	64.6	0	0	DJ	NC
S2U		S2U	02-66-2-L	OFFICER WR, WC, SH	47.6	0	0		
S2U		S2U	02-69-2-Q	CG LKR W/SINK	34	0	0	DJ	NC
S3I	S3U		(none)	(weather bulkhead)	34	0	0		
S4U			01-57-2-L	CPO SR	32.4	0	0		
S4U			01-60-0A-L	PASSAGE	24	0	0		
S4U			01-60-0B-L	PASSAGE	14.4	0	0		
S4U			01-60-0C-L	PASSAGE	24	0	0		
S4U			01-83-2-L	CPO SR	15.6	0	0		
S4U			03-56-0A-C	PILOT HOUSE	72	0	0		
S4U			03-66-01-C	ELEX, IC & GYRO ROOM	38.4	0	0		
			02-57-1-L	CO SR	(CUI = L1)				
NPU		NPU	02-57-0-L	CO CABIN	102	0	0	DJ	NO
NPU		NPU	02-63-1-L	CO WR, WC, SH	93.5	0	0	DJ	NO
S3I	S3U		(none)	(weather bulkhead)	102	0	0		
S3I	S3U		(none)	(weather bulkhead)	93.5	0	0		
S4U			01-57-0-Q	WARD ROOM PANTRY	36	0	0		
S4U			01-60-1-L	WARDROOM MESSROOM &	36	0	0		
S4I			03-56-0A-C	PILOT HOUSE	96	0	0		
S4I			(none)	(weather overhead)	36	0	0		
			02-57-2-L	XO WR, WC, SH	(CUI = LW)				
S2U		S2U	02-57-0C-L	PASSAGE	51	0	0		
NPU		NPU	02-57-4-L	XO SR	51	0	0		
NPU		NPU	02-57-4-L	XO SR	56.1	0	0	DJ	NO
S3I	S3U		(none)	(weather bulkhead)	56.1	0	0		
S4U			01-57-2-L	CPO SR	24	0	0		
S4U			01-57-4-L	CPO WR, WC, SH	15.6	0	0		
S4I			03-56-0A-C	PILOT HOUSE	39.6	0	0		
			02-57-4-L	XO SR	(CUI = L1)				
S2U		S2U	02-57-0C-L	PASSAGE	35.7	0	0	DJ	NC
NPU		NPU	02-57-2-L	XO WR, WC, SH	51	0	0		
NPU		NPU	02-57-2-L	XO WR, WC, SH	56.1	0	0	DJ	NO
NPU		NPU	02-63-2-L	OFFICER SR	127.5	0	0		
S3I	S3U		(none)	(weather bulkhead)	71.4	0	0		
S3I	S3U		(none)	(weather bulkhead)	86.7	0	0		
S4U			01-57-2-L	CPO SR	16.8	0	0		
S4U			01-57-4-L	CPO WR, WC, SH	45.6	0	0		
S4I			03-56-0A-C	PILOT HOUSE	93.6	0	0		
S4I			(none)	(weather overhead)	19.8	0	0		
			02-59-2-L	COMPANIONWAY	(CUI = LP)				
S2U		S2U	02-57-0-L	CO CABIN	34	0	0		

Table B.2 Barrier Data

Barrier Materials			Plan ID	Compartment Name Adjacent Compartment	Area sq ft	Therm adj	Durab adj	Doors / Hatches	DC Rating
<1>	<2>	<3>							
S2U		S2U	02-57-0-L	CO CABIN	34	0	0		
S2U		S2U	02-57-0C-L	PASSAGE	34	0	0		
S2U		S2U	02-61-2-L	COMPANIONWAY	34	0	0		
S4U			01-57-0-Q	WARD ROOM PANTRY	4	0	0		
S4U			01-57-2-L	CPO SR	4	0	0		
S4U			01-60-0C-L	PASSAGE	8	0	0		
S4U			03-56-0A-C	PILOT HOUSE	16	0	0		
			02-61-2-L	COMPANIONWAY	(CUI = LP)				
S2U		S2U	02-57-0-L	CO CABIN	85	0	0		
S2U		S2U	02-57-0C-L	PASSAGE	102	0	0	DJ	NC
S2U		S2U	02-59-2-L	COMPANIONWAY	34	0	0		
S3U		S3U	02-66-0-C	RADIO ROOM	34	0	0		
S3U		S3U	02-66-0-C	RADIO ROOM	17	0	0		
S4U			01-60-0B-L	PASSAGE	8	0	0		
S4U			01-60-0C-L	PASSAGE	40	0	0	HO	O
S4U			03-56-0A-C	PILOT HOUSE	40	0	0	HO	O
S4U			03-66-0-L	DECK WR & WC	4	0	0		
S4U			03-66-01-C	ELEX, IC & GYRO ROOM	4	0	0		
			02-63-1-L	CO WR, WC, SH	(CUI = LW)				
NPU		NPU	02-57-0-L	CO CABIN	51	0	0		
NPU		NPU	02-57-1-L	CO SR	93.5	0	0	DJ	NO
NPU		NPU	02-66-1-L	OFFICER WR, WC, SH	93.5	0	0		
S3I	S3U		(none)	(weather bulkhead)	51	0	0		
S4U			01-60-1-L	WARDROOM MESSROOM &	36	0	0		
S4I			03-56-0A-C	PILOT HOUSE	8.7	0	0		
S4I			03-56-0B-C	PILOT HOUSE (CHART A	3.3	0	0		
S4I			(none)	(weather overhead)	54	0	0		
			02-63-2-L	OFFICER SR	(CUI = L2)				
S2U		S2U	02-57-0C-L	PASSAGE	66.3	0	0	DJ	NC
NPU		NPU	02-57-4-L	XO SR	127.5	0	0		
NPU		NPU	02-66-2-L	OFFICER WR, WC, SH	56.1	0	0	DJ	NC
NPU		NPU	02-66-4-L	OFFICER WR, WC, SH	71.4	0	0		
S3I	S3U		(none)	(weather bulkhead)	66.3	0	0		
S4U			01-83-2-L	CPO SR	78	0	0		
S4I			03-56-0A-C	PILOT HOUSE	46.8	0	0		
S4I			(none)	(weather overhead)	70.2	0	0		
			02-66-0-C	RADIO ROOM	(CUI = C)				
S3I		S3U	02-57-0-L	CO CABIN	102	0	0		
S3U		S3U	02-57-0A-L	PASSAGE	136	0	0		
S3U		S3U	02-57-0C-L	PASSAGE	64.6	0	0	DJ	NC
S3U		S3U	02-61-2-L	COMPANIONWAY	34	0	0		
S3U		S3U	02-61-2-L	COMPANIONWAY	17	0	0		
S3I		S3U	02-66-1-L	OFFICER WR, WC, SH	47.6	0	0		
S3I		S3U	02-69-1-L	OFFICER SR	34	0	0		
S4U			01-60-0B-L	PASSAGE	49.6	0	0		
S4U			01-68-0-Q	SHIP OFFICE	60	0	0		
S4U			01-68-1-L	MEDICAL TREATMENT RO	36	0	0		
S4U			03-56-0B-C	PILOT HOUSE (CHART A	96	0	0	HS	X
S4U			03-66-0-L	DECK WR & WC	18.4	0	0		
S4U			03-66-01-C	ELEX, IC & GYRO ROOM	31.2	0	0		
			02-66-1-L	OFFICER WR, WC, SH	(CUI = LW)				
NPU		NPU	02-63-1-L	CO WR, WC, SH	93.5	0	0		
S3U		S3I	02-66-0-C	RADIO ROOM	47.6	0	0		
NPU		NPU	02-69-1-L	OFFICER SR	93.5	0	0	DJ	NO

Table B.2 Barrier Data

Barrier Materials			Plan ID	Compartment Name Adjacent Compartment	Area sq ft	Therm adj	Durab adj	Doors / Hatches	DC Rating
<1>	<2>	<3>							
S3I	S3U		(none)	(weather bulkhead)	47.6	0	0		
S4U			01-60-0B-L	PASSAGE	21.6	0	0		
S4U			01-68-1-L	MEDICAL TREATMENT RO	12	0	0		
S4U			03-56-0B-C	PILOT HOUSE (CHART A	11.2	0	0		
S4I			(none)	(weather overhead)	50.4	0	0		
			02-66-2-L	OFFICER WR, WC, SH	(CUI = LW)				
S2U	S2U		02-57-0C-L	PASSAGE	47.6	0	0		
NPU	NPU		02-63-2-L	OFFICER SR	56.1	0	0	DJ	NC
NPU	NPU		02-66-4-L	OFFICER WR, WC, SH	47.6	0	0		
S2U	S2U		02-69-2-Q	CG LKR W/SINK	34	0	0		
NPU	NPU		02-69-4-L	OFFICER SR	22.1	0	0		
S4U			01-66-2-L	PASSAGE	37	0	0		
S4I			03-56-0A-C	PILOT HOUSE	33.6	0	0		
S4I			(none)	(weather overhead)	3.4	0	0		
			02-66-4-L	OFFICER WR, WC, SH	(CUI = LW)				
NPU	NPU		02-63-2-L	OFFICER SR	71.4	0	0		
NPU	NPU		02-66-2-L	OFFICER WR, WC, SH	47.6	0	0		
NPU	NPU		02-69-4-L	OFFICER SR	71.4	0	0	DJ	NO
S3I	S3U		(none)	(weather bulkhead)	47.6	0	0		
S4U			01-66-2-L	PASSAGE	19	0	0		
S4I			(none)	(weather overhead)	47	0	0		
			02-69-1-L	OFFICER SR	(CUI = L2)				
S2U	S2U		02-57-0A-L	PASSAGE	34	0	0		
S2U	S2U		02-57-0B-L	PASSAGE	34	0	0	DJ	NC
S3U	S3I		02-66-0-C	RADIO ROOM	34	0	0		
NPU	NPU		02-66-1-L	OFFICER WR, WC, SH	93.5	0	0	DJ	NO
S3I	S3U		02-75-1-Q	PFD & SURVIVAL SUIT	93.5	0	0		
S3I	S3U		(none)	(weather bulkhead)	102	0	0		
S4U			01-68-1-L	MEDICAL TREATMENT RO	72	0	0		
S4I			03-56-0B-C	PILOT HOUSE (CHART A	16	0	0		
S4I			(none)	(weather overhead)	116	0	0		
			02-69-2-Q	CG LKR W/SINK	(CUI = AG)				
S2U	S2U		02-57-0A-L	PASSAGE	34	0	0		
S2U	S2U		02-57-0C-L	PASSAGE	34	0	0	DJ	NC
S2U	S2U		02-66-2-L	OFFICER WR, WC, SH	34	0	0		
S2U	S2U		02-69-4-L	OFFICER SR	34	0	0		
S4U			01-66-2-L	PASSAGE	16	0	0		
S4U			03-56-0A-C	PILOT HOUSE	16	0	0		
			02-69-4-L	OFFICER SR	(CUI = L2)				
S3U	S3U		02-57-0A-L	PASSAGE	34	0	0	DJ	NC
NPU	NPU		02-66-2-L	OFFICER WR, WC, SH	22.1	0	0		
NPU	NPU		02-66-4-L	OFFICER WR, WC, SH	71.4	0	0	DJ	NO
S2U	S2U		02-69-2-Q	CG LKR W/SINK	34	0	0		
S2U	S2U		02-73-0-Q	FAN ROOM	34	0	0		
S3I	S3U		02-75-2-Q	PFD & SURVIVAL SUIT	93.5	0	0		
S3I	S3U		(none)	(weather bulkhead)	102	0	0		
S4U			01-66-2-L	PASSAGE	7	0	0		
S4U			01-70-2-Q	C.G. LKR	17	0	0		
S4U			01-71-2-L	CPO WR, WC, SH	36	0	0		
S4I			01-74-2-L	CPO SR	12	0	0		
S4I			03-56-0A-C	PILOT HOUSE	16	0	0		
S4I			(none)	(weather overhead)	116	0	0		
			02-73-0-Q	FAN ROOM	(CUI = QF)				
S3U	S3U		1-76-0-Q	MMR (UPTAKE)	17	0	0		

Table B.2 Barrier Data

Barrier Materials			Plan ID	Compartment Name Adjacent Compartment	Area sq ft	Therm adj	Durab adj	Doors / Hatches	DC Rating
<1>	<2>	<3>							
S3U		S3U	1-76-0-Q	MMR (UPTAKE)	68	0	0		
S3I		S3U	1-76-0-Q	MMR (UPTAKE)	68	0	0		
S3I		S3U	1-80-1-Q	VENT PLENUM	34	0	0		
S3U		S3U	02-57-0A-L	PASSAGE	170	0	0		
S3U		S3U	02-57-0B-L	PASSAGE	68	0	0	DJ	NC
S2U		S2U	02-69-4-L	OFFICER SR	34	0	0		
S2U		S2U	02-75-2-Q	PFD & SURVIVAL SUIT	34	0	0		
S3I	S3U		(none)	(weather bulkhead)	68	0	0	DWT	Z
S3I	S3U		(none)	(weather bulkhead)	51	0	0		
S4U			01-60-0A-L	PASSAGE	32	0	0		
S4U			01-68-0-Q	SHIP OFFICE	36	0	0		
S4U			01-68-1-L	MEDICAL TREATMENT RO	4	0	0		
S4U			01-71-2-L	CPO WR, WC, SH	8	0	0		
S4U			01-74-1-L	MEDICAL TREATMENT WR	48	0	0		
S4I			01-74-2-L	CPO SR	24	0	0		
S4U			01-78-1-F	EMERGENCY GEN SERVIC	16	0	0		
S4I			03-76-0-Q	STACK	20	0	0		
S4I			(none)	(weather overhead)	148	0	0		
			02-75-1-Q	PFD & SURVIVAL SUIT LOCKER	(CUI = AG)				
S3U		S3U	02-57-0B-L	PASSAGE	34	0	0		
S3U		S3I	02-69-1-L	OFFICER SR	93.5	0	0		
S3U	S3U		(none)	(weather bulkhead)	93.5	0	0	DWT	Z
S3U	S3U		(none)	(weather bulkhead)	34	0	0		
S4U			01-68-1-L	MEDICAL TREATMENT RO	24	0	0		
S4I			(none)	(weather overhead)	44	0	0		
			02-75-2-Q	PFD & SURVIVAL SUIT LOCKER	(CUI = AG)				
S3U		S3I	02-69-4-L	OFFICER SR	93.5	0	0		
S2U		S2U	02-73-0-Q	FAN ROOM	34	0	0		
S3U	S3U		(none)	(weather bulkhead)	93.5	0	0	DWT	Z
S3U	S3U		(none)	(weather bulkhead)	34	0	0		
S4I			01-74-2-L	CPO SR	24	0	0		
S4I			(none)	(weather overhead)	44	0	0		
			02-85-0-Q	INCINERATOR ROOM	(CUI = QG)				
S3I		S3U	1-76-0-Q	MMR (UPTAKE)	68	0	0		
S3I	S3U		(none)	(weather bulkhead)	102	0	0	DWT	Z
S3I	S3U		(none)	(weather bulkhead)	68	0	0		
S3I	S3U		(none)	(weather bulkhead)	68	0	0		
S3I	S3U		(none)	(weather bulkhead)	17	0	0		
S3I	S3U		(none)	(weather bulkhead)	17	0	0		
S4I			01-78-3-E	EMERGENCY GENERATOR	4	0	0		
S4I			01-79-0A-L	PASSAGE	16	0	0		
S4I			01-79-0B-L	PASSAGE	56	0	0		
S4I			01-88-0-L	CREW SR	17.2	0	0		
S4I			01-88-1-L	CREW WR, WC & SH	2.8	0	0		
S4U			(none)	(weather overhead)	96	0	0		
			03-56-0A-C	PILOT HOUSE	(CUI = C)				
S2U		S2U	03-56-0B-C	PILOT HOUSE (CHART A	51	0	0		
000		000	03-56-0B-C	PILOT HOUSE (CHART A	53.8	0	0	DO	O
S3U		S3U	03-66-0-L	DECK WR & WC	34	0	0	DJ	NC
S2U		S2U	03-66-01-C	ELEX, IC & GYRO ROOM	115.6	0	0		
S2U		S2U	03-66-01-C	ELEX, IC & GYRO ROOM	51	0	0	DJ	NC
S3I	S3U		(none)	(weather bulkhead)	51	0	0		
S3I	S3U		(none)	(weather bulkhead)	68	0	0	DWT	Z
S3I	S3U		(none)	(weather bulkhead)	76.5	0	0		

Table B.2 Barrier Data

Barrier Materials			Plan ID	Compartment Name	Area sq ft	Therm adj	Durab adj	Doors / Hatches	DC Rating
<1>	<2>	<3>							
S3I	S3U		(none)	(weather bulkhead)	68	0	0		
S3I	S3U		(none)	(weather bulkhead)	391	0	0		
S3I	S3U		(none)	(weather bulkhead)	68	0	0		
S3I	S3U		(none)	(weather bulkhead)	76.5	0	0		
S3I	S3U		(none)	(weather bulkhead)	200.6	0	0	DWT	Z
S4U			02-57-0-L	CO CABIN	229.3	0	0		
S4I			02-57-0A-L	PASSAGE	16	0	0		
S4U			02-57-0C-L	PASSAGE	72	0	0		
S4I			02-57-1-L	CO SR	96	0	0		
S4I			02-57-2-L	XO WR, WC, SH	39.6	0	0		
S4I			02-57-4-L	XO SR	93.6	0	0		
S4U			02-59-2-L	COMPANIONWAY	16	0	0		
S4U			02-61-2-L	COMPANIONWAY	40	0	0	HO	O
S4I			02-63-1-L	CO WR, WC, SH	8.7	0	0		
S4I			02-63-2-L	OFFICER SR	46.8	0	0		
S4I			02-66-2-L	OFFICER WR, WC, SH	33.6	0	0		
S4U			02-69-2-Q	CG LKR W/SINK	16	0	0		
S4I			02-69-4-L	OFFICER SR	16	0	0		
S4I			(none)	(weather overhead)	723.6	0	0		
			03-56-0B-C	PILOT HOUSE (CHART AREA)	(CUI = C)				
S2U		S2U	03-56-0A-C	PILOT HOUSE	51	0	0		
000		000	03-56-0A-C	PILOT HOUSE	53.8	0	0	DO	O
S3U		S3U	03-66-0-L	DECK WR & WC	47.6	0	0		
S2U		S2U	03-66-01-C	ELEX, IC & GYRO ROOM	68	0	0		
S3I	S3U		(none)	(weather bulkhead)	102	0	0		
S3I	S3U		(none)	(weather bulkhead)	132.6	0	0		
S4U			02-57-0-L	CO CABIN	2.7	0	0		
S4I			02-57-0A-L	PASSAGE	40	0	0		
S4I			02-63-1-L	CO WR, WC, SH	3.3	0	0		
S4U			02-66-0-C	RADIO ROOM	96	0	0	HS	X
S4U			02-66-1-L	OFFICER WR, WC, SH	11.2	0	0		
S4I			02-69-1-L	OFFICER SR	16	0	0		
S4I			(none)	(weather overhead)	169.2	0	0		
			03-66-0-L	DECK WR & WC	(CUI = LW)				
S3U		S3U	03-56-0A-C	PILOT HOUSE	34	0	0	DJ	NC
S3U		S3U	03-56-0B-C	PILOT HOUSE (CHART A	47.6	0	0		
S3U		S3U	03-66-01-C	ELEX, IC & GYRO ROOM	47.6	0	0		
S3U		S3U	03-66-01-C	ELEX, IC & GYRO ROOM	34	0	0		
S4U			02-61-2-L	COMPANIONWAY	4	0	0		
S4U			02-66-0-C	RADIO ROOM	18.4	0	0		
S4I			(none)	(weather overhead)	22.4	0	0		
			03-66-01-C	ELEX, IC & GYRO ROOM	(CUI = C)				
S2U		S2U	03-56-0A-C	PILOT HOUSE	115.6	0	0		
S2U		S2U	03-56-0A-C	PILOT HOUSE	51	0	0	DJ	NC
S2U		S2U	03-56-0B-C	PILOT HOUSE (CHART A	68	0	0		
S3U		S3U	03-66-0-L	DECK WR & WC	47.6	0	0		
S3U		S3U	03-66-0-L	DECK WR & WC	34	0	0		
S3I	S3U		(none)	(weather bulkhead)	85	0	0		
S4I			02-57-0A-L	PASSAGE	40	0	0		
S4U			02-57-0C-L	PASSAGE	38.4	0	0		
S4U			02-61-2-L	COMPANIONWAY	4	0	0		
S4U			02-66-0-C	RADIO ROOM	31.2	0	0		
S4I			(none)	(weather overhead)	113.6	0	0		
			03-76-0-Q	STACK	(CUI = TU)				

Table B.2 Barrier Data

Barrier Materials			Plan ID	Compartment Name Adjacent Compartment	Area sq ft	Therm adj	Durab adj	Doors / Hatches	DC Rating
<1>	<2>	<3>							
S3U	S3U		(none)	(weather bulkhead)	102	0	0		
S3U	S3U		(none)	(weather bulkhead)	153	0	0		
S3U	S3U		(none)	(weather bulkhead)	102	0	0		
S3U	S3U		(none)	(weather bulkhead)	153	0	0		
S4U			1-76-0-Q	MMR (UPTAKE)	144	0	0		
S4U			1-80-1-Q	VENT PLENUM	8	0	0		
S4I			02-73-0-Q	FAN ROOM	20	0	0		
S4U			(none)	(weather overhead)	216	0	0		

Table B.3 Fire Safety Objectives

Plan ID	Compartment Name	MAL Rating	FAL (Years)	FREQ EB
CUI=AA	(Cargo Hold)			
2-30-0-AA	CARGO HOLD	3	13	0.0001
CUI=AG	(Gear Locker)			
3-6-0-Q	CHAIN LOCKER SUMP	4	8	0.001
2-6-1-Q	CHAIN LOCKER	4	8	0.001
2-6-2-Q	CHAIN LOCKER	4	8	0.001
1-77-1-A	CREW LOCKER	3	15	0.001
1-82-2-Q	C.G. LKR W/ SINK	4	8	0.001
01-70-2-Q	C.G. LKR	4	8	0.001
01-85-2-Q	FOUL WEATHER GEAR LKR	3	19	0.001
02-69-2-Q	CG LKR W/SINK	4	8	0.001
02-75-1-Q	PFD & SURVIVAL SUIT LOCKER	3	17	0.001
02-75-2-Q	PFD & SURVIVAL SUIT LOCKER	3	17	0.001
CUI=AR	(Refrigerated Storage)			
1-60-2-A	CHILL STRM	2	23	0.0009
1-60-4-A	FREEZE STRM	2	23	0.0009
CUI=AS	(Storeroom)			
3-57-0-A	SUPPLY DEPT. STOREROOM NO. 2	4	8	0.0009
2-21-1-A	SUPPLY DEPT STOREROOM NO. 1	4	8	0.0009
2-50-1-A	ENGINEER STOREROOM	4	8	0.0009
2-57-2-A	SHIP STORE	3	13	0.0009
1-0-0-A	BOATSWAIN STOREROOM NO. 1	3	13	0.0009
1-6-1-A	BOATSWAIN STOREROOM NO. 2	3	13	0.0009
1-18-4-A	ATON STRM	3	17	0.0009
1-60-6A-A	DRY PROVISION STOREROOM	3	13	0.0009
1-60-6B-A	DRY PROVISION STOREROOM	3	13	0.0009
1-102-2-A	DECK GEAR STOREROOM	3	13	0.0009
CUI=C	(Ship Control/Communications)			
2-89-1-C	ENGINEERING CONTROL CENTER	2	24	0.0012
01-27-0-C	BUOY DECK CONTROL BOOTH	2	22	0.0012
02-66-0-C	RADIO ROOM	2	26	0.0012
03-56-0A-C	PILOT HOUSE	2	26	0.0012
03-56-0B-C	PILOT HOUSE (CHART AREA)	2	26	0.0012
03-66-01-C	ELEX, IC & GYRO ROOM	2	24	0.0012
CUI=EM	(Main Propulsion - Mechanical)			
4-12-0-E	BOWTHRUSTER MCHRY ROOM	2	24	0.0272
4-66-0-E	MAIN MACHINERY ROOM	2	26	0.0272
4-92-0-E	STERN THRUSTER MACHRY ROOM	2	24	0.0272
1-102-0-E	STEERING GEAR ROOM	2	26	0.0272
CUI=K	(Hazardous Material Storage)			
1-6-2-A	FLAM. LIQ. STOREROOM	1	30	0.0013
CUI=L1	(Senior Officer's Cabin)			
02-57-0-L	CO CABIN	3	15	0.0008
02-57-1-L	CO SR	3	15	0.0008
02-57-4-L	XO SR	3	15	0.0008
CUI=L2	(Officer/CPO Quarters)			
01-57-2-L	CPO SR	3	15	0.0008
01-74-2-L	CPO SR	3	15	0.0008
01-80-0-L	CREW SR	3	15	0.0008
01-83-2-L	CPO SR	3	15	0.0008
01-86-1-L	CREW SR	3	15	0.0008
01-88-0-L	CREW SR	3	15	0.0008
01-88-2-L	CREW SR	3	15	0.0008
02-63-2-L	OFFICER SR	3	15	0.0008

Table B.3 Fire Safety Objectives

Plan ID	Compartment Name	MAL Rating	FAL (Years)	FREQ EB
02-69-1-L	OFFICER SR	3	15	0.0008
02-69-4-L	OFFICER SR	3	15	0.0008
CUI=L5	(Crews Berthing)			
1-85-1-L	CREW SR	3	15	0.0008
1-85-3-L	CREW SR	3	15	0.0008
1-85-4-L	CREW SR	3	15	0.0008
1-92-1-L	CREW SR	3	15	0.0008
1-92-2-L	CREW SR	3	15	0.0008
1-96-0-L	CREW SR	3	15	0.0008
CUI=LL	(Wardroom/Mess/Lounge Areas)			
1-66-0-L	CREW MESS	2	24	0.0008
1-77-2-L	CPO MESS & LOUNGE	3	16	0.0008
1-77-3-L	CREW LOUNGE	3	16	0.0008
01-60-1-L	WARDROOM MESSROOM & LOUNGE	2	24	0.0008
CUI=LM	(Medical/Dental Spaces)			
01-68-1-L	MEDICAL TREATMENT ROOM	2	22	0.0004
CUI=LP	(Passageway/Staircase/Vestibule)			
3-21-0-L	PASSAGE	3	16	0.0001
2-21-0-L	PASSAGE	3	16	0.0001
2-36-1-L	PASSAGE	3	16	0.0001
2-39-1-L	PASSAGE	3	16	0.0001
2-48-1-L	PASSAGE	3	16	0.0001
2-53-1-L	VESTIBULE	3	16	0.0001
2-57-0-L	PASSAGE	3	16	0.0001
1-12-1A-L	PASSAGE	3	16	0.0001
1-12-1B-L	PASSAGE	3	16	0.0001
1-15-1-L	COMPANIONWAY	3	16	0.0001
1-21-1-L	VESTIBULE	3	16	0.0001
1-21-3-L	COMPANIONWAY	3	16	0.0001
1-57-2-L	PASSAGE	3	16	0.0001
1-59-2-L	COMPANIONWAY	3	16	0.0001
1-66-2-L	COMPANIONWAY	3	16	0.0001
1-82-0-L	PASSAGE	3	16	0.0001
1-84-2-L	COMPANIONWAY	3	16	0.0001
1-92-0-L	PASSAGE	3	16	0.0001
01-60-0A-L	PASSAGE	3	16	0.0001
01-60-0B-L	PASSAGE	3	16	0.0001
01-60-0C-L	PASSAGE	3	16	0.0001
01-66-2-L	PASSAGE	3	16	0.0001
01-79-0A-L	PASSAGE	3	16	0.0001
01-79-0B-L	PASSAGE	3	16	0.0001
01-92-0-L	COMPANIONWAY	3	16	0.0001
02-57-0A-L	PASSAGE	3	16	0.0001
02-57-0B-L	PASSAGE	3	16	0.0001
02-57-0C-L	PASSAGE	3	16	0.0001
02-59-2-L	COMPANIONWAY	3	16	0.0001
02-61-2-L	COMPANIONWAY	3	16	0.0001
CUI=LW	(Sanitary Spaces)			
1-57-0-L	DECK WR & WC	4	8	0.0002
1-57-4-Q	CHANGE ROOM	4	8	0.0002
1-60-1-L	GALLEY WR & WC	4	8	0.0002
1-82-1-L	CREW WR, WC & SH	4	8	0.0002
1-82-3-L	CREW WR, WC & SH	4	8	0.0002
1-82-4-L	CREW WR, WC & SH	4	8	0.0002

Table B.3 Fire Safety Objectives

Plan ID	Compartment Name	MAL Rating	FAL (Years)	FREQ EB
1-96-1-L	CREW WR, WC & SH	4	8	0.0002
1-97-4-L	CREW WR, WC & SH	4	8	0.0002
1-98-1-L	CREW WR, WC & SH	4	8	0.0002
01-57-4-L	CPO WR, WC, SH	4	8	0.0002
01-71-2-L	CPO WR, WC, SH	4	8	0.0002
01-74-1-L	MEDICAL TREATMENT WR, WC & SH	4	8	0.0002
01-84-2-L	CREW WR, WC & SH	4	8	0.0002
01-88-1-L	CREW WR, WC & SH	4	8	0.0002
02-57-2-L	XO WR, WC, SH	4	8	0.0002
02-63-1-L	CO WR, WC, SH	4	8	0.0002
02-66-1-L	OFFICER WR, WC, SH	4	8	0.0002
02-66-2-L	OFFICER WR, WC, SH	4	8	0.0002
02-66-4-L	OFFICER WR, WC, SH	4	8	0.0002
03-66-0-L	DECK WR & WC	4	8	0.0002
CUI=QA	(Aux Machinery Spaces)			
4-82-0-E	AUXILIARY MACHINERY ROOM	2	22	0.0029
2-21-2-Q	POTABLE WATER PUMP ROOM	2	24	0.0029
2-48-2-E	SOR PUMP ROOM	2	23	0.0029
2-49-0-E	SOR MACHINERY ROOM	2	23	0.0029
2-57-4-E	WATER SUPPLY EQPT ROOM	2	22	0.0029
1-18-1-Q	D.C. REPAIR LKR NO. 1	2	24	0.0029
1-18-2-Q	AFFF STA.	2	24	0.0029
1-74-2-Q	DC REPAIR LKR NO. 2	2	24	0.0029
1-85-2-Q	AFFF STA.	2	24	0.0029
CUI=QE	(Emergency Aux Generator Spaces)			
01-78-1-F	EMERGENCY GEN SERVICE TK	4	8	0.0204
01-78-3-E	EMERGENCY GENERATOR ROOM	2	24	0.0204
CUI=QF	(Fan Room)			
1-97-2-Q	FAN ROOM	2	22	0.0004
02-73-0-Q	FAN ROOM	2	22	0.0004
CUI=QG	(Galley/Pantry/Scullery)			
1-57-1-Q	GALLEY	2	26	0.0026
1-66-1-Q	GALLEY ANNEX	2	26	0.0026
1-66-3-Q	SCULLERY	2	26	0.0026
01-57-0-Q	WARD ROOM PANTRY	2	26	0.0026
02-85-0-Q	INCINERATOR ROOM	4	8	0.0026
CUI=QL	(Laundry)			
1-105-2-Q	LAUNDRY	3	16	0.0031
CUI=QO	(Office Spaces)			
1-71-2-Q	ENG LOG OFFICE & DC CENTRAL	2	22	0.0004
01-68-0-Q	SHIP OFFICE	2	22	0.0004
CUI=QS	(Shops)			
2-57-1-Q	MACHINE SHOP	2	20	0.0018
2-59-1-Q	ELEC/ELEX WORKSHOP & STORERM	2	20	0.0018
1-12-3-Q	BOATSWAIN SHOP	2	20	0.0018
1-21-2-Q	ATON SHOP	2	23	0.0018
CUI=TH	(Trunks/Hoists/Dumbwaiters)			
3-23-0-Q	CRANE PEDESTAL	2	22	0.0001
1-19-2-T	ESC TRUNK	4	8	0.0001
1-57-3-Q	DUMBWAITER TRUNK	3	13	0.0001
1-80-1-E	VENT PLENUM	3	13	0.0001
1-80-1-Q	VENT PLENUM	3	13	0.0001
CUI=TU	(Stacks/Engine Uptakes)			
1-76-0-Q	MMR (UPTAKE)	3	16	0.0013

Table B.3 Fire Safety Objectives

Plan ID	Compartment Name	MAL Rating	FAL (Years)	FREQ EB
03-76-0-Q	STACK	2	21	0.0013
CUI=V	(Voids/Cofferdams)			
4-17-2-V	VOID	4	8	0.0001
4-37-2-V	VOID	4	8	0.0001
4-39-0-V	VOID	4	8	0.0001
4-39-0A-V	VOID	4	8	0.0001
4-39-0C-V	VOID	4	8	0.0001
3-51-0-V	VOID	4	8	0.0001
2-39-0-V	COFFERDAM	4	8	0.0001
2-39-2-V	VOID	4	8	0.0001
2-48-0-V	COFFERDAM	4	8	0.0001
CUI=W	(Water Tank (empty))			
4-21-0A-W	SW BALLAST TANK	4	8	0.0004
4-21-0B-W	SW BALLAST TANK	4	8	0.0004
4-21-0C-W	SW BALLAST TANK	4	8	0.0004
4-30-3-W	SW BALLAST TANK	4	8	0.0004
4-30-4-W	SW BALLAST TANK	4	8	0.0004
4-48-0A-W	SW BALLAST TANK	4	8	0.0004
4-48-0B-W	SW BALLAST TANK	4	8	0.0004
4-48-0C-W	SW BALLAST TANK	4	8	0.0004
4-57-0A-W	SW BALLAST TANK	4	8	0.0004
4-57-0B-W	SW BALLAST TANK	4	8	0.0004
4-57-0C-W	SW BALLAST TANK	4	8	0.0004
4-80-0-W	SEA BAY	4	8	0.0004
4-0-0-W	SW BALLAST TANK	4	8	0.0004
4-6-0A-W	SW BALLAST TANK	4	8	0.0004
4-6-0B-W	SW BALLAST TANK	4	8	0.0004
4-6-0C-W	SW BALLAST TANK	4	8	0.0004
2-25-1-WW	POTABLE WATER (CARGO)	4	8	0.0004
2-25-2-W	POTABLE WATER (SHIP)	4	8	0.0004

Table B-4 Fire Detection

Plan ID	Compartment Name	Detection Systems	% Time Monitored		Est. Minutes to Detect	
			at Sea	In Port	at Sea	In Port
CUI=AA	(Cargo Hold)					
2-30-0-AA	CARGO HOLD	2 Smoke	95	95	1	1
CUI=AG	(Gear Locker)					
3-6-0-Q	CHAIN LOCKER SUMP	None	10	10	14	14
2-6-1-Q	CHAIN LOCKER	None	10	10	14	14
2-6-2-Q	CHAIN LOCKER	None	10	10	14	14
1-77-1-A	CREW LOCKER	None	0	0	16	16
1-82-2-Q	C.G. LKR W/ SINK	None	0	0	16	16
01-70-2-Q	C.G. LKR	None	0	0	16	16
01-85-2-Q	FOUL WEATHER GEAR LKR	None	0	0	16	16
02-69-2-Q	CG LKR W/SINK	None	0	0	16	16
02-75-1-Q	PFD & SURVIVAL SUIT LOCKER	None	0	0	16	16
02-75-2-Q	PFD & SURVIVAL SUIT LOCKER	None	0	0	16	16
CUI=AR	(Refrigerated Storage)					
1-60-2-A	CHILL STRM	None	5	0	15	16
1-60-4-A	FREEZE STRM	None	5	0	15	16
CUI=AS	(Storeroom)					
3-57-0-A	SUPPLY DEPT. STOREROOM NO. 2	1 Smoke	95	95	1	1
2-21-1-A	SUPPLY DEPT STOREROOM NO. 1	1 Smoke	95	95	1	1
2-50-1-A	ENGINEER STOREROOM	1 Temp	95	95	1	1
2-57-2-A	SHIP STORE	1 Smoke	95	95	1	1
1-0-0-A	BOATSWAIN STOREROOM NO. 1	1 Smoke	95	95	1	1
1-6-1-A	BOATSWAIN STOREROOM NO. 2	1 Smoke	95	95	1	1
1-18-4-A	ATON STRM	1 Smoke	95	95	1	1
1-60-6A-A	DRY PROVISION STOREROOM	1 Smoke	95	95	1	1
1-60-6B-A	DRY PROVISION STOREROOM	None	95	95	1	1
1-102-2-A	DECK GEAR STOREROOM	1 Smoke	95	95	1	1
CUI=C	(Ship Control/Communications)					
2-89-1-C	ENGINEERING CONTROL CENTER	1 Smoke	95	95	1	1
01-27-0-C	BUOY DECK CONTROL BOOTH	None	50	25	6	11
02-66-0-C	RADIO ROOM	1 Smoke	95	95	1	1
03-56-0A-C	PILOT HOUSE	2 Smoke	100	95	1	1
03-56-0B-C	PILOT HOUSE (CHART AREA)	1 Smoke	100	95	1	1
03-66-01-C	ELEX, IC & GYRO ROOM	1 Smoke	95	95	1	1
CUI=EM	(Main Propulsion - Mechanical)					
4-12-0-E	BOWTHRUSTER MCHRY ROOM	2 Smoke	95	95	1	1
4-66-0-E	MAIN MACHINERY ROOM	9 Smoke	99	99	1	1
4-92-0-E	STERN THRUSTER MACHRY ROOM	1 Smoke	95	95	1	1
1-102-0-E	STEERING GEAR ROOM	1 Smoke	76	95	1	1
CUI=K	(Hazardous Material Storage)					
1-6-2-A	FLAM. LIQ. STOREROOM	1 Temp	95	95	1	1
CUI=L1	(Senior Officer's Cabin)					
02-57-0-L	CO CABIN	1 Smoke	95	95	1	1
02-57-1-L	CO SR	1 Smoke	95	95	1	1
02-57-4-L	XO SR	1 Smoke	95	95	1	1
CUI=L2	(Officer/CPO Quarters)					
01-57-2-L	CPO SR	1 Smoke	95	95	1	1
01-74-2-L	CPO SR	1 Smoke	95	95	1	1
01-80-0-L	CREW SR	1 Smoke	95	95	1	1
01-83-2-L	CPO SR	1 Smoke	95	95	1	1
01-86-1-L	CREW SR	1 Smoke	95	95	1	1
01-88-0-L	CREW SR	1 Smoke	95	95	1	1
01-88-2-L	CREW SR	1 Smoke	95	95	1	1
02-63-2-L	OFFICER SR	1 Smoke	95	95	1	1

Table B-4 Fire Detection

Plan ID	Compartment Name	Detection Systems	% Time Monitored		Est. Minutes to Detect	
			at Sea	In Port	at Sea	In Port
02-69-1-L	OFFICER SR	1 Smoke	95	95	1	1
02-69-4-L	OFFICER SR	1 Smoke	95	95	1	1
CUI=L5	(Crews Berthing)					
1-85-1-L	CREW SR	2 Smoke	95	95	1	1
1-85-3-L	CREW SR	2 Smoke	95	95	1	1
1-85-4-L	CREW SR	2 Smoke	95	95	1	1
1-92-1-L	CREW SR	2 Smoke	95	95	1	1
1-92-2-L	CREW SR	2 Smoke	95	95	1	1
1-96-0-L	CREW SR	2 Smoke	95	95	1	1
CUI=LL	(Wardroom/Mess/Lounge Areas)					
1-66-0-L	CREW MESS	2 Smoke	95	95	1	1
1-77-2-L	CPO MESS & LOUNGE	1 Smoke	95	95	1	1
1-77-3-L	CREW LOUNGE	1 Smoke	95	95	1	1
01-60-1-L	WARDROOM MESSROOM & LOUNGE	1 Smoke	95	95	1	1
CUI=LM	(Medical/Dental Spaces)					
01-68-1-L	MEDICAL TREATMENT ROOM	1 Smoke	95	95	1	1
CUI=LP	(Passageway/Staircase/Vestibule)					
3-21-0-L	PASSAGE	1 Smoke	95	95	1	1
2-21-0-L	PASSAGE	1 Smoke	95	95	1	1
2-36-1-L	PASSAGE	1 Temp	95	95	1	1
2-39-1-L	PASSAGE	1 Temp	95	95	1	1
2-48-1-L	PASSAGE	1 Temp	95	95	1	1
2-53-1-L	VESTIBULE	1 Smoke	95	95	1	1
2-57-0-L	PASSAGE	1 Smoke	95	95	1	1
1-12-1A-L	PASSAGE	1 Smoke	95	95	1	1
1-12-1B-L	PASSAGE	None	95	95	1	1
1-15-1-L	COMPANIONWAY	1 Smoke	95	95	1	1
1-21-1-L	VESTIBULE	1 Smoke	95	95	1	1
1-21-3-L	COMPANIONWAY	1 Smoke	95	95	1	1
1-57-2-L	PASSAGE	1 Smoke	95	95	1	1
1-59-2-L	COMPANIONWAY	1 Smoke	95	95	1	1
1-66-2-L	COMPANIONWAY	1 Smoke	95	95	1	1
1-82-0-L	PASSAGE	1 Smoke	95	95	1	1
1-84-2-L	COMPANIONWAY	1 Smoke	95	95	1	1
1-92-0-L	PASSAGE	1 Smoke	95	95	1	1
01-60-0A-L	PASSAGE	None	60	60	4	4
01-60-0B-L	PASSAGE	1 Smoke	95	95	1	1
01-60-0C-L	PASSAGE	None	95	95	1	1
01-66-2-L	PASSAGE	1 Smoke	95	95	1	1
01-79-0A-L	PASSAGE	None	95	95	1	1
01-79-0B-L	PASSAGE	1 Smoke	95	95	1	1
01-92-0-L	COMPANIONWAY	1 Smoke	95	95	1	1
02-57-0A-L	PASSAGE	None	35	35	9	9
02-57-0B-L	PASSAGE	None	70	70	2	2
02-57-0C-L	PASSAGE	1 Smoke	95	95	1	1
02-59-2-L	COMPANIONWAY	1 Smoke	95	95	1	1
02-61-2-L	COMPANIONWAY	1 Smoke	95	95	1	1
CUI=LW	(Sanitary Spaces)					
1-57-0-L	DECK WR & WC	None	20	15	12	13
1-57-4-Q	CHANGE ROOM	1 Smoke	95	95	1	1
1-60-1-L	GALLEY WR & WC	None	20	15	12	13
1-82-1-L	CREW WR, WC & SH	None	20	15	12	13
1-82-3-L	CREW WR, WC & SH	None	20	15	12	13
1-82-4-L	CREW WR, WC & SH	None	20	15	12	13

Table B-4 Fire Detection

Plan ID	Compartment Name	Detection Systems	% Time Monitored		Est. Minutes to Detect	
			at Sea	In Port	at Sea	In Port
1-96-1-L	CREW WR, WC & SH	None	20	15	12	13
1-97-4-L	CREW WR, WC & SH	None	20	15	12	13
1-98-1-L	CREW WR, WC & SH	None	20	15	12	13
01-57-4-L	CPO WR, WC, SH	None	20	15	12	13
01-71-2-L	CPO WR, WC, SH	None	20	15	12	13
01-74-1-L	MEDICAL TREATMENT WR, WC & SH	None	20	15	12	13
01-84-2-L	CREW WR, WC & SH	None	20	15	12	13
01-88-1-L	CREW WR, WC & SH	None	20	15	12	13
02-57-2-L	XO WR, WC, SH	None	20	15	12	13
02-63-1-L	CO WR, WC, SH	None	20	15	12	13
02-66-1-L	OFFICER WR, WC, SH	None	20	15	12	13
02-66-2-L	OFFICER WR, WC, SH	None	20	15	12	13
02-66-4-L	OFFICER WR, WC, SH	None	20	15	12	13
03-66-0-L	DECK WR & WC	None	20	15	12	13
CUI=QA	(Aux Machinery Spaces)					
4-82-0-E	AUXILIARY MACHINERY ROOM	4 Smoke	99	99	1	1
2-21-2-Q	POTABLE WATER PUMP ROOM	1 Smoke	95	95	14	14
2-48-2-E	SOR PUMP ROOM	1 Smoke	95	95	1	1
2-49-0-E	SOR MACHINERY ROOM	1 Smoke	95	95	1	1
2-57-4-E	WATER SUPPLY EQPT ROOM	1 Smoke	95	95	1	1
1-18-1-Q	D.C. REPAIR LKR NO. 1	1 Smoke	95	95	16	16
1-18-2-Q	AFFF STA.	None	95	95	1	1
1-74-2-Q	DC REPAIR LKR NO. 2	1 Smoke	95	95	16	16
1-85-2-Q	AFFF STA.	None	95	95	1	1
CUI=QE	(Emergency Aux Generator Spaces)					
01-78-1-F	EMERGENCY GEN SERVICE TK	None	0	0	16	16
01-78-3-E	EMERGENCY GENERATOR ROOM	1 Smoke	95	95	1	1
CUI=QF	(Fan Room)					
1-97-2-Q	FAN ROOM	1 Smoke	95	95	1	1
02-73-0-Q	FAN ROOM	1 Smoke	95	95	1	1
CUI=QG	(Galley/Pantry/Scullery)					
1-57-1-Q	GALLEY	1 Smoke	95	95	1	1
1-66-1-Q	GALLEY ANNEX	1 Smoke	95	95	1	1
1-66-3-Q	SCULLERY	1 Smoke	95	95	1	1
01-57-0-Q	WARD ROOM PANTRY	1 Smoke	95	95	1	1
02-85-0-Q	INCINERATOR ROOM	1 Smoke	95	95	1	1
CUI=QL	(Laundry)					
1-105-2-Q	LAUNDRY	1 Smoke	95	95	1	1
CUI=QO	(Office Spaces)					
1-71-2-Q	ENG LOG OFFICE & DC CENTRAL	1 Smoke	95	95	1	1
01-68-0-Q	SHIP OFFICE	1 Smoke	95	95	1	1
CUI=QS	(Shops)					
2-57-1-Q	MACHINE SHOP	1 Smoke	95	95	1	1
2-59-1-Q	ELEC/ELEX WORKSHOP & STORERM	1 Smoke	95	95	1	1
1-12-3-Q	BOATSWAIN SHOP	1 Smoke	95	95	1	1
1-21-2-Q	ATON SHOP	1 Smoke	95	95	1	1
CUI=TH	(Trunks/Hoists/Dumbwaiters)					
3-23-0-Q	CRANE PEDESTAL	None	15	10	13	14
1-19-2-T	ESC TRUNK	None	15	10	13	14
1-57-3-Q	DUMBWAITER TRUNK	None	15	10	13	14
1-80-1-E	VENT PLENUM	None	15	10	13	14
1-80-1-Q	VENT PLENUM	None	15	10	13	14
CUI=TU	(Stacks/Engine Uptakes)					
1-76-0-Q	MMR (UPTAKE)	None	0	0	16	16

Table B-4 Fire Detection

Plan ID	Compartment Name	Detection Systems	% Time Monitored		Est. Minutes to Detect	
			at Sea	In Port	at Sea	in Port
03-76-0-Q	STACK	None	0	0	16	16
CUI=V	(Voids/Cofferdams)					
4-17-2-V	VOID	None	0	0	16	16
4-37-2-V	VOID	None	0	0	16	16
4-39-0-V	VOID	None	0	0	16	16
4-39-0A-V	VOID	None	0	0	16	16
4-39-0C-V	VOID	None	0	0	16	16
3-51-0-V	VOID	None	0	0	16	16
2-39-0-V	COFFERDAM	None	0	0	16	16
2-39-2-V	VOID	None	0	0	16	16
2-48-0-V	COFFERDAM	None	0	0	16	16
CUI=W	(Water Tank (empty))					
4-21-0A-W	SW BALLAST TANK	None	0	0	16	16
4-21-0B-W	SW BALLAST TANK	None	0	0	16	16
4-21-0C-W	SW BALLAST TANK	None	0	0	16	16
4-30-3-W	SW BALLAST TANK	None	0	0	16	16
4-30-4-W	SW BALLAST TANK	None	0	0	16	16
4-48-0A-W	SW BALLAST TANK	None	0	0	16	16
4-48-0B-W	SW BALLAST TANK	None	0	0	16	16
4-48-0C-W	SW BALLAST TANK	None	0	0	16	16
4-57-0A-W	SW BALLAST TANK	None	0	0	16	16
4-57-0B-W	SW BALLAST TANK	None	0	0	16	16
4-57-0C-W	SW BALLAST TANK	None	0	0	16	16
4-80-0-W	SEA BAY	None	0	0	16	16
4-0-0-W	SW BALLAST TANK	None	0	0	16	16
4-6-0A-W	SW BALLAST TANK	None	0	0	16	16
4-6-0B-W	SW BALLAST TANK	None	0	0	16	16
4-6-0C-W	SW BALLAST TANK	None	0	0	16	16
2-25-1-WW	POTABLE WATER (CARGO)	None	0	0	16	16
2-25-2-W	POTABLE WATER (SHIP)	None	0	0	16	16

Table B.5 Automated and Manual Fire Protection Systems

Plan ID	Compartment Name	Fixed Systems (Installed)	Manual Firefighting Equipment (Available)		
			Portable Extinguishers	Hose / AFFF	Fire Main
CUI=AA	(Cargo Hold)				
2-30-0-AA	CARGO HOLD	1 Water Sprinkler	None	None	2 SW
CUI=AG	(Gear Locker)				
3-6-0-Q	CHAIN LOCKER SUMP	None	None	None	None
2-6-1-Q	CHAIN LOCKER	None	None	None	None
2-6-2-Q	CHAIN LOCKER	None	None	None	None
1-77-1-A	CREW LOCKER	None	None	None	None
1-82-2-Q	C.G. LKR W/ SINK	None	None	None	None
01-70-2-Q	C.G. LKR	None	None	None	None
01-85-2-Q	FOUL WEATHER GEAR LKR	None	None	None	None
02-69-2-Q	CG LKR W/SINK	None	None	None	None
02-75-1-Q	PFD & SURVIVAL SUIT LOCKER	None	None	None	None
02-75-2-Q	PFD & SURVIVAL SUIT LOCKER	None	None	None	None
CUI=AR	(Refrigerated Storage)				
1-60-2-A	CHILL STRM	None	None	None	None
1-60-4-A	FREEZE STRM	None	None	None	None
CUI=AS	(Storeroom)				
3-57-0-A	SUPPLY DEPT. STOREROOM NO. 2	None	None	None	None
2-21-1-A	SUPPLY DEPT STOREROOM NO. 1	None	None	None	None
2-50-1-A	ENGINEER STOREROOM	None	None	None	None
2-57-2-A	SHIP STORE	None	None	None	None
1-0-0-A	BOATSWAIN STOREROOM NO. 1	None	None	None	None
1-6-1-A	BOATSWAIN STOREROOM NO. 2	None	None	None	None
1-18-4-A	ATON STRM	None	None	None	None
1-60-6A-A	DRY PROVISION STOREROOM	None	None	None	None
1-60-6B-A	DRY PROVISION STOREROOM	None	None	None	None
1-102-2-A	DECK GEAR STOREROOM	None	1 CO2	None	None
CUI=C	(Ship Control/Communications)				
2-89-1-C	ENGINEERING CONTROL CENTER	None	1 CO2	None	None
01-27-0-C	BUOY DECK CONTROL BOOTH	None	None	None	None
02-66-0-C	RADIO ROOM	None	1 CO2	None	None
03-56-0A-C	PILOT HOUSE	None	1 CO2	None	None
03-56-0B-C	PILOT HOUSE (CHART AREA)	None	None	None	None
03-66-01-C	ELEX, IC & GYRO ROOM	None	1 CO2	None	None
CUI=EM	(Main Propulsion - Mechanical)				
4-12-0-E	BOWTHRUSTER MCHRY ROOM	1 AFFF Sprinkler	1 CO2, 2 PKP	None	1 AFFF
4-66-0-E	MAIN MACHINERY ROOM	1 AFFF Sprinkler, 1 CO2 Total Flooding	2 CO2, 2 Halon, 2 PKP	None	1 AFFF, 1 SW
4-92-0-E	STERN THRUSTER MACHRY ROOM	1 AFFF Sprinkler	1 CO2, 2 PKP	None	1 AFFF, 1 SW
1-102-0-E	STEERING GEAR ROOM	1 AFFF Sprinkler	2 PKP	None	None
CUI=K	(Hazardous Material Storage)				
1-6-2-A	FLAM. LIQ. STOREROOM	1 CO2 Total Flooding	1 PKP	None	None
CUI=L1	(Senior Officer's Cabin)				
02-57-0-L	CO CABIN	None	None	None	None
02-57-1-L	CO SR	None	None	None	None
02-57-4-L	XO SR	None	None	None	None
CUI=L2	(Officer/CPO Quarters)				
01-57-2-L	CPO SR	None	None	None	None
01-74-2-L	CPO SR	None	None	None	None
01-80-0-L	CREW SR	None	None	None	None
01-83-2-L	CPO SR	None	None	None	None
01-86-1-L	CREW SR	None	None	None	None

Table B.5 Automated and Manual Fire Protection Systems

Plan ID	Compartment Name	Fixed Systems (Installed)	Manual Firefighting Equipment (Available)		
			Portable Extinguishers	Hose / AFFF	Fire Main
01-88-0-L	CREW SR	None	None	None	None
01-88-2-L	CREW SR	None	None	None	None
02-63-2-L	OFFICER SR	None	None	None	None
02-69-1-L	OFFICER SR	None	None	None	None
02-69-4-L	OFFICER SR	None	None	None	None
CUI=L5	(Crews Berthing)				
1-85-1-L	CREW SR	None	None	None	None
1-85-3-L	CREW SR	None	None	None	None
1-85-4-L	CREW SR	None	None	None	None
1-92-1-L	CREW SR	None	None	None	None
1-92-2-L	CREW SR	None	None	None	None
1-96-0-L	CREW SR	None	None	None	None
CUI=LL	(Wardroom/Mess/Lounge Areas)				
1-66-0-L	CREW MESS	None	1 CO2, 2 PKP	None	1 AFFF, 1 SW
1-77-2-L	CPO MESS & LOUNGE	None	1 PKP	None	None
1-77-3-L	CREW LOUNGE	None	1 PKP	None	None
01-60-1-L	WARDROOM MESSROOM & LOUNGE	None	1 PKP	None	None
CUI=LM	(Medical/Dental Spaces)				
01-68-1-L	MEDICAL TREATMENT ROOM	None	None	None	None
CUI=LP	(Passageway/Staircase/Vestibule)				
3-21-0-L	PASSAGE	None	None	None	None
2-21-0-L	PASSAGE	None	1 CO2	None	1 SW
2-36-1-L	PASSAGE	None	None	None	None
2-39-1-L	PASSAGE	None	1 CO2	None	None
2-48-1-L	PASSAGE	None	None	None	1 SW
2-53-1-L	VESTIBULE	None	1 Halon	None	None
2-57-0-L	PASSAGE	None	1 CO2	None	1 SW
1-12-1A-L	PASSAGE	None	1 Halon, 1 PKP	None	1 AFFF, 1 SW
1-12-1B-L	PASSAGE	None	None	None	None
1-15-1-L	COMPANIONWAY	None	1 Halon	None	None
1-21-1-L	VESTIBULE	None	None	None	None
1-21-3-L	COMPANIONWAY	None	None	None	1 SW
1-57-2-L	PASSAGE	None	1 CO2	None	1 SW
1-59-2-L	COMPANIONWAY	None	None	None	None
1-66-2-L	COMPANIONWAY	None	None	None	None
1-82-0-L	PASSAGE	None	None	None	2 AFFF
1-84-2-L	COMPANIONWAY	None	None	None	None
1-92-0-L	PASSAGE	None	1 CO2, 1 PKP	None	2 AFFF
01-60-0A-L	PASSAGE	None	None	None	1 SW
01-60-0B-L	PASSAGE	None	None	None	None
01-60-0C-L	PASSAGE	None	1 CO2, 1 PKP	None	1 SW
01-66-2-L	PASSAGE	None	None	None	None
01-79-0A-L	PASSAGE	None	None	None	1 SW
01-79-0B-L	PASSAGE	None	O2, 1 Halon, 1 P	None	None
01-92-0-L	COMPANIONWAY	None	None	None	None
02-57-0A-L	PASSAGE	None	2 CO2	None	None
02-57-0B-L	PASSAGE	None	1 PKP	None	None
02-57-0C-L	PASSAGE	None	1 PKP	None	None
02-59-2-L	COMPANIONWAY	None	None	None	None
02-61-2-L	COMPANIONWAY	None	None	None	None
CUI=LW	(Sanitary Spaces)				
1-57-0-L	DECK WR & WC	None	None	None	None

Table B.5 Automated and Manual Fire Protection Systems

Plan ID	Compartment Name	Fixed Systems (Installed)	Manual Firefighting Equipment (Available)		
			Portable Extinguishers	Hose / AFFF	Fire Main
1-57-4-Q	CHANGE ROOM	None	1 PKP	None	None
1-60-1-L	GALLEY WR & WC	None	None	None	None
1-82-1-L	CREW WR, WC & SH	None	None	None	None
1-82-3-L	CREW WR, WC & SH	None	None	None	None
1-82-4-L	CREW WR, WC & SH	None	None	None	None
1-96-1-L	CREW WR, WC & SH	None	None	None	None
1-97-4-L	CREW WR, WC & SH	None	None	None	None
1-98-1-L	CREW WR, WC & SH	None	None	None	None
01-57-4-L	CPO WR, WC, SH	None	None	None	None
01-71-2-L	CPO WR, WC, SH	None	None	None	None
01-74-1-L	MEDICAL TREATMENT WR, WC & SH	None	None	None	None
01-84-2-L	CREW WR, WC & SH	None	None	None	None
01-88-1-L	CREW WR, WC & SH	None	None	None	None
02-57-2-L	XO WR, WC, SH	None	None	None	None
02-63-1-L	CO WR, WC, SH	None	None	None	None
02-66-1-L	OFFICER WR, WC, SH	None	None	None	None
02-66-2-L	OFFICER WR, WC, SH	None	None	None	None
02-66-4-L	OFFICER WR, WC, SH	None	None	None	None
03-66-0-L	DECK WR & WC	None	None	None	None
CUI=QA	(Aux Machinery Spaces)				
4-82-0-E	AUXILIARY MACHINERY ROOM	1 AFFF Sprinkler, 1 CO2 Total Flooding	1 CO2, 1 Halon, 3 PKP	None	1 AFFF, 1 SW
2-21-2-Q	POTABLE WATER PUMP ROOM	None	None	None	None
2-48-2-E	SOR PUMP ROOM	None	None	None	None
2-49-0-E	SOR MACHINERY ROOM	1 AFFF Sprinkler	2 PKP	None	None
2-57-4-E	WATER SUPPLY EQPT ROOM	None	1 CO2, 1 PKP	None	None
1-18-1-Q	D.C. REPAIR LKR NO. 1	None	None	None	None
1-18-2-Q	AFFF STA.	None	None	None	None
1-74-2-Q	DC REPAIR LKR NO. 2	None	2 CO2, 1 PKP	None	None
1-85-2-Q	AFFF STA.	None	1 CO2, 1 PKP	None	None
CUI=QE	(Emergency Aux Generator Spaces)				
01-78-1-F	EMERGENCY GEN SERVICE TK	None	None	None	None
01-78-3-E	EMERGENCY GENERATOR ROOM	1 CO2 Total Flooding	2 PKP	None	None
CUI=QF	(Fan Room)				
1-97-2-Q	FAN ROOM	None	None	None	None
02-73-0-Q	FAN ROOM	None	None	None	None
CUI=QG	(Galley/Pantry/Scullery)				
1-57-1-Q	GALLEY	1 APC	1 PKP	None	None
1-66-1-Q	GALLEY ANNEX	None	None	None	None
1-66-3-Q	SCULLERY	None	None	None	None
01-57-0-Q	WARD ROOM PANTRY	1 APC	1 PKP	None	None
02-85-0-Q	INCINERATOR ROOM	1 AFFF Sprinkler	1 CO2, 2 PKP	None	None
CUI=QL	(Laundry)				
1-105-2-Q	LAUNDRY	None	1 PKP	None	None
CUI=QO	(Office Spaces)				
1-71-2-Q	ENG LOG OFFICE & DC CENTRAL	None	None	None	None
01-68-0-Q	SHIP OFFICE	None	None	None	None
CUI=QS	(Shops)				
2-57-1-Q	MACHINE SHOP	None	None	None	None
2-59-1-Q	ELEC/ELEX WORKSHOP & STORERM	None	1 PKP	None	None
1-12-3-Q	BOATSWAIN SHOP	None	1 PKP	None	None
1-21-2-Q	ATON SHOP	None	1 CO2, 1 PKP	None	None

Table B.5 Automated and Manual Fire Protection Systems

Plan ID	Compartment Name	Fixed Systems (Installed)	Manual Firefighting Equipment (Available)		
			Portable Extinguishers	Hose / AFFF	Fire Main
CUI=TH	(Trunks/Hoists/Dumbwaiters)				
3-23-0-Q	CRANE PEDESTAL	None	None	None	None
1-19-2-T	ESC TRUNK	None	None	None	None
1-57-3-Q	DUMBWAITER TRUNK	None	None	None	None
1-80-1-E	VENT PLENUM	None	None	None	None
1-80-1-Q	VENT PLENUM	None	None	None	None
CUI=TU	(Stacks/Engine Uptakes)				
1-76-0-Q	MMR (UPTAKE)	None	None	None	None
03-76-0-Q	STACK	None	None	None	None
CUI=V	(Voids/Cofferdams)				
4-17-2-V	VOID	None	None	None	None
4-37-2-V	VOID	None	None	None	None
4-39-0-V	VOID	None	None	None	None
4-39-0A-V	VOID	None	None	None	None
4-39-0C-V	VOID	None	None	None	None
3-51-0-V	VOID	None	None	None	None
2-39-0-V	COFFERDAM	None	None	None	None
2-39-2-V	VOID	None	None	None	None
2-48-0-V	COFFERDAM	None	None	None	None
CUI=W	(Water Tank (empty))				
4-21-0A-W	SW BALLAST TANK	None	None	None	None
4-21-0B-W	SW BALLAST TANK	None	None	None	None
4-21-0C-W	SW BALLAST TANK	None	None	None	None
4-30-3-W	SW BALLAST TANK	None	None	None	None
4-30-4-W	SW BALLAST TANK	None	None	None	None
4-48-0A-W	SW BALLAST TANK	None	None	None	None
4-48-0B-W	SW BALLAST TANK	None	None	None	None
4-48-0C-W	SW BALLAST TANK	None	None	None	None
4-57-0A-W	SW BALLAST TANK	None	None	None	None
4-57-0B-W	SW BALLAST TANK	None	None	None	None
4-57-0C-W	SW BALLAST TANK	None	None	None	None
4-80-0-W	SEA BAY	None	None	None	None
4-0-0-W	SW BALLAST TANK	None	None	None	None
4-6-0A-W	SW BALLAST TANK	None	None	None	None
4-6-0B-W	SW BALLAST TANK	None	None	None	None
4-6-0C-W	SW BALLAST TANK	None	None	None	None
2-25-1-WW	POTABLE WATER (CARGO)	None	None	None	None
2-25-2-W	POTABLE WATER (SHIP)	None	None	None	None

Table B.6.1 Probability of Flame Termination (In-Port)

Plan ID	Compartment Name	I Values			A Values			M Values		
		EB	TBAR	DBAR	EB	TBAR	DBAR	EB	TBAR	DBAR
CUI=AA	(Cargo Hold) Frequency of EB=0.0001									
2-30-0-AA	CARGO HOLD	91	100	68	40	40	20	20	36	15
CUI=AG	(Gear Locker) Frequency of EB=0.0010									
3-6-0-Q	CHAIN LOCKER SUMP	99	100	59	0	0	0	6	7	3
2-6-1-Q	CHAIN LOCKER	99	100	59	0	0	0	6	7	3
2-6-2-Q	CHAIN LOCKER	99	100	59	0	0	0	6	7	3
1-77-1-A	CREW LOCKER	27	33	16	0	0	0	16	19	9
1-82-2-Q	C.G. LKR W/ SINK	27	33	16	0	0	0	16	19	9
01-70-2-Q	C.G. LKR	27	33	16	0	0	0	16	19	9
01-85-2-Q	FOUL WEATHER GEAR LKR	27	33	16	0	0	0	16	19	9
02-69-2-Q	CG LKR W/SINK	27	33	16	0	0	0	16	19	9
02-75-1-Q	PFD & SURVIVAL SUIT LOCKER	15	33	16	0	0	0	16	19	9
02-75-2-Q	PFD & SURVIVAL SUIT LOCKER	15	33	16	0	0	0	16	19	9
CUI=AR	(Refrigerated Storage) Frequency of EB=0.0009									
1-60-2-A	CHILL STRM	66	79	52	0	0	0	22	26	17
1-60-4-A	FREEZE STRM	66	79	52	0	0	0	22	26	17
CUI=AS	(Storeroom) Frequency of EB=0.0009									
3-57-0-A	SUPPLY DEPT. STOREROOM NO. 2	39	42	23	0	0	0	22	44	22
2-21-1-A	SUPPLY DEPT STOREROOM NO. 1	39	42	23	0	0	0	22	44	22
2-50-1-A	ENGINEER STOREROOM	39	42	23	0	0	0	22	44	22
2-57-2-A	SHIP STORE	39	42	23	0	0	0	22	44	22
1-0-0-A	BOATSWAIN STOREROOM NO. 1	39	42	23	0	0	0	22	44	22
1-6-1-A	BOATSWAIN STOREROOM NO. 2	39	42	23	0	0	0	22	44	22
1-18-4-A	ATON STRM	39	42	23	0	0	0	22	44	22
1-60-6A-A	DRY PROVISION STOREROOM	39	42	23	0	0	0	22	44	22
1-60-6B-A	DRY PROVISION STOREROOM	39	42	23	0	0	0	22	44	22
1-102-2-A	DECK GEAR STOREROOM	39	42	23	0	0	0	22	44	22
CUI=C	(Ship Control/Communications) Frequency of EB=0.0012									
2-89-1-C	ENGINEERING CONTROL CENTER	46	50	27	0	0	0	24	26	14
01-27-0-C	BUOY DECK CONTROL BOOTH	63	69	37	0	0	0	16	17	9
02-66-0-C	RADIO ROOM	35	38	21	0	0	0	24	26	14
03-56-0A-C	PILOT HOUSE	49	53	29	0	0	0	24	26	14
03-56-0B-C	PILOT HOUSE (CHART AREA)	49	53	29	0	0	0	24	26	14
03-66-01-C	ELEX, IC & GYRO ROOM	39	42	23	0	0	0	24	26	14
CUI=EM	(Main Propulsion - Mechanical) Frequency of EB=0.0272									
4-12-0-E	BOWTHRUSTER MCHRY ROOM	69	66	36	67	67	33	10	12	6
4-66-0-E	MAIN MACHINERY ROOM	54	66	36	70	70	35	9	11	5
4-92-0-E	STERN THRUSTER MACHRY ROOM	69	66	36	52	52	26	10	12	6
1-102-0-E	STEERING GEAR ROOM	63	69	37	42	42	21	8	10	4
CUI=K	(Hazardous Material Storage) Frequency of EB=0.0013									
1-6-2-A	FLAM. LIQ. STOREROOM	15	15	7	64	64	32	20	20	10
CUI=L1	(Senior Officer's Cabin) Frequency of EB=0.0008									
02-57-0-L	CO CABIN	49	58	24	0	0	0	20	26	12
02-57-1-L	CO SR	49	58	24	0	0	0	20	26	12
02-57-4-L	XO SR	49	58	24	0	0	0	20	26	12

Table B.6.1 Probability of Flame Termination (In-Port)

Plan ID	Compartment Name	I Values			A Values			M Values		
		EB	TBAR	DBAR	EB	TBAR	DBAR	EB	TBAR	DBAR
CUI=L2	(Officer/CPO Quarters) Frequency of EB=0.0008									
01-57-2-L	CPO SR	50	55	30	0	0	0	20	32	14
01-74-2-L	CPO SR	50	55	30	0	0	0	20	32	14
01-80-0-L	CREW SR	50	55	30	0	0	0	20	32	14
01-83-2-L	CPO SR	50	55	30	0	0	0	20	32	14
01-86-1-L	CREW SR	50	55	30	0	0	0	20	32	14
01-88-0-L	CREW SR	50	55	30	0	0	0	20	32	14
01-88-2-L	CREW SR	50	55	30	0	0	0	20	32	14
02-63-2-L	OFFICER SR	50	55	30	0	0	0	20	32	14
02-69-1-L	OFFICER SR	50	55	30	0	0	0	20	32	14
02-69-4-L	OFFICER SR	50	55	30	0	0	0	20	32	14
CUI=L5	(Crews Berthing) Frequency of EB=0.0008									
1-85-1-L	CREW SR	59	59	35	0	0	0	21	42	18
1-85-3-L	CREW SR	59	59	35	0	0	0	21	42	18
1-85-4-L	CREW SR	59	59	35	0	0	0	21	42	18
1-92-1-L	CREW SR	59	59	35	0	0	0	21	42	18
1-92-2-L	CREW SR	59	59	35	0	0	0	21	42	18
1-96-0-L	CREW SR	59	59	35	0	0	0	21	42	18
CUI=LL	(Wardroom/Mess/Lounge Areas) Frequency of EB=0.0008									
1-66-0-L	CREW MESS	31	34	18	0	0	0	31	38	18
1-77-2-L	CPO MESS & LOUNGE	31	34	18	0	0	0	31	38	18
1-77-3-L	CREW LOUNGE	31	34	18	0	0	0	31	38	18
01-60-1-L	WARDROOM MESSROOM & LOUNGE	31	34	18	0	0	0	31	38	18
CUI=LM	(Medical/Dental Spaces) Frequency of EB=0.0004									
01-68-1-L	MEDICAL TREATMENT ROOM	35	38	21	0	0	0	24	30	14
CUI=LP	(Passageway/Staircase/Vestibule) Frequency of EB=0.0001									
3-21-0-L	PASSAGE	79	79	71	0	0	0	50	55	45
2-21-0-L	PASSAGE	79	79	71	0	0	0	50	55	45
2-36-1-L	PASSAGE	79	79	71	0	0	0	50	55	45
2-39-1-L	PASSAGE	79	79	71	0	0	0	50	55	45
2-48-1-L	PASSAGE	79	79	71	0	0	0	50	55	45
2-53-1-L	VESTIBULE	86	86	77	0	0	0	50	55	45
2-57-0-L	PASSAGE	79	79	71	0	0	0	50	55	45
1-12-1A-L	PASSAGE	79	79	71	0	0	0	50	55	45
1-12-1B-L	PASSAGE	79	79	71	0	0	0	50	55	45
1-15-1-L	COMPANIONWAY	86	86	77	0	0	0	50	55	45
1-21-1-L	VESTIBULE	86	86	77	0	0	0	50	55	45
1-21-3-L	COMPANIONWAY	86	86	77	0	0	0	50	55	45
1-57-2-L	PASSAGE	79	79	71	0	0	0	50	55	45
1-59-2-L	COMPANIONWAY	86	86	77	0	0	0	50	55	45
1-66-2-L	COMPANIONWAY	86	86	77	0	0	0	50	55	45
1-82-0-L	PASSAGE	79	79	71	0	0	0	50	55	45
1-84-2-L	COMPANIONWAY	86	86	77	0	0	0	50	55	45
1-92-0-L	PASSAGE	79	79	71	0	0	0	50	55	45
01-60-0A-L	PASSAGE	79	79	71	0	0	0	50	55	45
01-60-0B-L	PASSAGE	79	79	71	0	0	0	50	55	45
01-60-0C-L	PASSAGE	79	79	71	0	0	0	50	55	45
01-66-2-L	PASSAGE	79	79	71	0	0	0	50	55	45
01-79-0A-L	PASSAGE	79	79	71	0	0	0	50	55	45

Table B.6.1 Probability of Flame Termination (In-Port)

Plan ID	Compartment Name	I Values			A Values			M Values		
		EB	TBAR	DBAR	EB	TBAR	DBAR	EB	TBAR	DBAR
01-79-0B-L	PASSAGE	79	79	71	0	0	0	50	55	45
01-92-0-L	COMPANIONWAY	86	86	77	0	0	0	50	55	45
02-57-0A-L	PASSAGE	79	79	71	0	0	0	50	55	45
02-57-0B-L	PASSAGE	79	79	71	0	0	0	50	55	45
02-57-0C-L	PASSAGE	79	79	71	0	0	0	50	55	45
02-59-2-L	COMPANIONWAY	86	86	77	0	0	0	50	55	45
02-61-2-L	COMPANIONWAY	86	86	77	0	0	0	50	55	45
CUI=LW	(Sanitary Spaces) Frequency of EB=0.0002									
1-57-0-L	DECK WR & WC	92	92	73	0	0	0	20	22	18
1-57-4-Q	CHANGE ROOM	92	92	73	0	0	0	47	51	42
1-60-1-L	GALLEY WR & WC	92	92	73	0	0	0	20	22	18
1-82-1-L	CREW WR, WC & SH	92	92	73	0	0	0	20	22	18
1-82-3-L	CREW WR, WC & SH	92	92	73	0	0	0	20	22	18
1-82-4-L	CREW WR, WC & SH	92	92	73	0	0	0	20	22	18
1-96-1-L	CREW WR, WC & SH	92	92	73	0	0	0	20	22	18
1-97-4-L	CREW WR, WC & SH	92	92	73	0	0	0	20	22	18
1-98-1-L	CREW WR, WC & SH	92	92	73	0	0	0	20	22	18
01-57-4-L	CPO WR, WC, SH	92	92	73	0	0	0	20	22	18
01-71-2-L	CPO WR, WC, SH	92	92	73	0	0	0	20	22	18
01-74-1-L	MEDICAL TREATMENT WR, WC & SH	92	92	73	0	0	0	20	22	18
01-84-2-L	CREW WR, WC & SH	92	92	73	0	0	0	20	22	18
01-88-1-L	CREW WR, WC & SH	92	92	73	0	0	0	20	22	18
02-57-2-L	XO WR, WC, SH	92	92	73	0	0	0	20	22	18
02-63-1-L	CO WR, WC, SH	92	92	73	0	0	0	20	22	18
02-66-1-L	OFFICER WR, WC, SH	92	92	73	0	0	0	20	22	18
02-66-2-L	OFFICER WR, WC, SH	92	92	73	0	0	0	20	22	18
02-66-4-L	OFFICER WR, WC, SH	92	92	73	0	0	0	20	22	18
03-66-0-L	DECK WR & WC	92	92	73	0	0	0	20	22	18
CUI=QA	(Aux Machinery Spaces) Frequency of EB=0.0029									
4-82-0-E	AUXILIARY MACHINERY ROOM	50	50	35	70	70	35	10	11	7
2-21-2-Q	POTABLE WATER PUMP ROOM	50	50	35	0	0	0	10	11	7
2-48-2-E	SOR PUMP ROOM	50	50	35	52	52	26	10	11	7
2-49-0-E	SOR MACHINERY ROOM	50	50	35	52	52	26	10	11	7
2-57-4-E	WATER SUPPLY EQPT ROOM	50	50	35	0	0	0	10	11	7
1-18-1-Q	D.C. REPAIR LKR NO. 1	50	50	35	0	0	0	10	11	7
1-18-2-Q	AFFF STA.	50	50	35	0	0	0	6	6	4
1-74-2-Q	DC REPAIR LKR NO. 2	50	50	35	0	0	0	26	28	19
1-85-2-Q	AFFF STA.	50	50	35	0	0	0	14	15	10
CUI=QE	(Emergency Aux Generator Spaces) Frequency of EB=0.0204									
01-78-1-F	EMERGENCY GEN SERVICE TK	0	0	0	0	0	0	0	0	0
01-78-3-E	EMERGENCY GENERATOR ROOM	43	43	25	64	64	32	10	11	7
CUI=QF	(Fan Room) Frequency of EB=0.0004									
1-97-2-Q	FAN ROOM	66	52	39	0	0	0	44	100	33
02-73-0-Q	FAN ROOM	66	52	39	0	0	0	44	100	33
CUI=QG	(Galley/Pantry/Scullery) Frequency of EB=0.0026									
1-57-1-Q	GALLEY	79	79	47	0	0	0	21	29	16
1-66-1-Q	GALLEY ANNEX	79	79	47	0	0	0	21	29	16
1-66-3-Q	SCULLERY	79	79	47	0	0	0	37	51	29
01-57-0-Q	WARD ROOM PANTRY	79	79	47	0	0	0	21	29	16

Table B.6.1 Probability of Flame Termination (In-Port)

Plan ID	Compartment Name	I Values			A Values			M Values		
		EB	TBAR	DBAR	EB	TBAR	DBAR	EB	TBAR	DBAR
02-85-0-Q	INCINERATOR ROOM	40	40	24	52	52	26	23	32	18
CUI=QL	(Laundry) Frequency of EB=0.0031									
1-105-2-Q	LAUNDRY	35	43	26	0	0	0	26	39	15
CUI=QO	(Office Spaces) Frequency of EB=0.0004									
1-71-2-Q	ENG LOG OFFICE & DC CENTRAL	27	32	16	0	0	0	23	28	13
01-68-0-Q	SHIP OFFICE	27	32	16	0	0	0	23	28	13
CUI=QS	(Shops) Frequency of EB=0.0018									
2-57-1-Q	MACHINE SHOP	39	42	23	0	0	0	26	31	15
2-59-1-Q	ELEC/ELEX WORKSHOP & STORERM	39	42	23	0	0	0	26	31	15
1-12-3-Q	BOATSWAIN SHOP	39	42	23	0	0	0	26	31	15
1-21-2-Q	ATON SHOP	39	42	23	0	0	0	26	31	15
CUI=TH	(Trunks/Hoists/Dumbwaiters) Frequency of EB=0.0001									
3-23-0-Q	CRANE PEDESTAL	98	100	58	0	0	0	6	7	3
1-19-2-T	ESC TRUNK	98	100	58	0	0	0	22	26	13
1-57-3-Q	DUMBWAITER TRUNK	98	100	58	0	0	0	22	26	13
1-80-1-E	VENT PLENUM	98	100	58	0	0	0	22	26	13
1-80-1-Q	VENT PLENUM	98	100	58	0	0	0	22	26	13
CUI=TU	(Stacks/Engine Uptakes) Frequency of EB=0.0013									
1-76-0-Q	MMR (UPTAKE)	19	15	8	0	0	0	0	0	0
03-76-0-Q	STACK	19	15	8	0	0	0	4	5	2
CUI=V	(Voids/Cofferdams) Frequency of EB=0.0001									
4-17-2-V	VOID	100	100	100	0	0	0	30	30	30
4-37-2-V	VOID	100	100	100	0	0	0	30	30	30
4-39-0-V	VOID	100	100	100	0	0	0	30	30	30
4-39-0A-V	VOID	100	100	100	0	0	0	30	30	30
4-39-0C-V	VOID	100	100	100	0	0	0	30	30	30
3-51-0-V	VOID	100	100	100	0	0	0	30	30	30
2-39-0-V	COFFERDAM	100	100	100	0	0	0	30	30	30
2-39-2-V	VOID	100	100	100	0	0	0	30	30	30
2-48-0-V	COFFERDAM	100	100	100	0	0	0	30	30	30
CUI=W	(Water Tank (empty)) Frequency of EB=0.0004									
4-21-0A-W	SW BALLAST TANK	100	100	100	0	0	0	30	30	30
4-21-0B-W	SW BALLAST TANK	100	100	100	0	0	0	30	30	30
4-21-0C-W	SW BALLAST TANK	100	100	100	0	0	0	30	30	30
4-30-3-W	SW BALLAST TANK	100	100	100	0	0	0	30	30	30
4-30-4-W	SW BALLAST TANK	100	100	100	0	0	0	30	30	30
4-48-0A-W	SW BALLAST TANK	100	100	100	0	0	0	30	30	30
4-48-0B-W	SW BALLAST TANK	100	100	100	0	0	0	30	30	30
4-48-0C-W	SW BALLAST TANK	100	100	100	0	0	0	30	30	30
4-57-0A-W	SW BALLAST TANK	100	100	100	0	0	0	30	30	30
4-57-0B-W	SW BALLAST TANK	100	100	100	0	0	0	30	30	30
4-57-0C-W	SW BALLAST TANK	100	100	100	0	0	0	30	30	30
4-80-0-W	SEA BAY	100	100	100	0	0	0	30	30	30
4-0-0-W	SW BALLAST TANK	100	100	100	0	0	0	30	30	30
4-6-0A-W	SW BALLAST TANK	100	100	100	0	0	0	30	30	30
4-6-0B-W	SW BALLAST TANK	100	100	100	0	0	0	30	30	30
4-6-0C-W	SW BALLAST TANK	100	100	100	0	0	0	30	30	30
2-25-1-WW	POTABLE WATER (CARGO)	100	100	100	0	0	0	30	30	30

Table B.6.1 Probability of Flame Termination (In-Port)

Plan ID	Compartment Name	I Values			A Values			M Values		
		EB	TBAR	DBAR	EB	TBAR	DBAR	EB	TBAR	DBAR
2-25-2-W	POTABLE WATER (SHIP)	100	100	100	0	0	0	30	30	30

Table B.6.2 Probability of Flame Termination (At-Sea)

Plan ID	Compartment Name	I Values			A Values			M Values		
		EB	TBAR	DBAR	EB	TBAR	DBAR	EB	TBAR	DBAR
CUI=AA	(Cargo Hold) Frequency of EB=0.0001									
2-30-0-AA	CARGO HOLD	91	100	68	40	40	20	25	45	18
CUI=AG	(Gear Locker) Frequency of EB=0.0010									
3-6-0-Q	CHAIN LOCKER SUMP	99	100	59	0	0	0	9	10	5
2-6-1-Q	CHAIN LOCKER	99	100	59	0	0	0	9	10	5
2-6-2-Q	CHAIN LOCKER	99	100	59	0	0	0	9	10	5
1-77-1-A	CREW LOCKER	27	33	16	0	0	0	25	30	15
1-82-2-Q	C.G. LKR W/ SINK	27	33	16	0	0	0	25	30	15
01-70-2-Q	C.G. LKR	27	33	16	0	0	0	25	30	15
01-85-2-Q	FOUL WEATHER GEAR LKR	27	33	16	0	0	0	25	30	15
02-69-2-Q	CG LKR W/SINK	27	33	16	0	0	0	25	30	15
02-75-1-Q	PFD & SURVIVAL SUIT LOCKER	15	18	9	0	0	0	25	30	15
02-75-2-Q	PFD & SURVIVAL SUIT LOCKER	15	18	9	0	0	0	25	30	15
CUI=AR	(Refrigerated Storage) Frequency of EB=0.0009									
1-60-2-A	CHILL STRM	66	79	52	0	0	0	34	40	27
1-60-4-A	FREEZE STRM	66	79	52	0	0	0	34	40	27
CUI=AS	(Storeroom) Frequency of EB=0.0009									
3-57-0-A	SUPPLY DEPT. STOREROOM NO. 2	39	42	23	0	0	0	28	56	28
2-21-1-A	SUPPLY DEPT STOREROOM NO. 1	39	42	23	0	0	0	28	56	28
2-50-1-A	ENGINEER STOREROOM	39	42	23	0	0	0	28	56	28
2-57-2-A	SHIP STORE	39	42	23	0	0	0	28	56	28
1-0-0-A	BOATSWAIN STOREROOM NO. 1	39	42	23	0	0	0	28	56	28
1-6-1-A	BOATSWAIN STOREROOM NO. 2	39	42	23	0	0	0	28	56	28
1-18-4-A	ATON STRM	39	42	23	0	0	0	28	56	28
1-60-6A-A	DRY PROVISION STOREROOM	39	42	23	0	0	0	28	56	28
1-60-6B-A	DRY PROVISION STOREROOM	39	42	23	0	0	0	28	56	28
1-102-2-A	DECK GEAR STOREROOM	39	42	23	0	0	0	28	56	28
CUI=C	(Ship Control/Communications) Frequency of EB=0.0012									
2-89-1-C	ENGINEERING CONTROL CENTER	46	50	27	0	0	0	29	31	17
01-27-0-C	BUOY DECK CONTROL BOOTH	63	69	37	0	0	0	25	27	15
02-66-0-C	RADIO ROOM	35	38	21	0	0	0	29	31	17
03-56-0A-C	PILOT HOUSE	49	53	29	0	0	0	31	34	18
03-56-0B-C	PILOT HOUSE (CHART AREA)	49	53	29	0	0	0	31	34	18
03-66-01-C	ELEX, IC & GYRO ROOM	39	42	23	0	0	0	29	31	17
CUI=EM	(Main Propulsion - Mechanical) Frequency of EB=0.0272									
4-12-0-E	BOWTHRUSTER MCHRY ROOM	69	75	41	67	67	33	13	16	7
4-66-0-E	MAIN MACHINERY ROOM	54	59	32	70	70	35	13	16	7
4-92-0-E	STERN THRUSTER MACHRY ROOM	69	75	41	52	52	26	10	12	6
1-102-0-E	STEERING GEAR ROOM	63	69	37	42	42	21	10	12	6
CUI=K	(Hazardous Material Storage) Frequency of EB=0.0013									
1-6-2-A	FLAM. LIQ. STOREROOM	15	15	7	64	64	32	12	12	6
CUI=L1	(Senior Officer's Cabin) Frequency of EB=0.0008									
02-57-0-L	CO CABIN	49	58	24	0	0	0	25	32	15
02-57-1-L	CO SR	49	58	24	0	0	0	25	32	15
02-57-4-L	XO SR	49	58	24	0	0	0	25	32	15

Table B.6.2 Probability of Flame Termination (At-Sea)

CUI=L2	(Officer/CPO Quarters) Frequency of EB=0.0008									
01-57-2-L	CPO SR	50	55	30	0	0	0	25	40	17
01-74-2-L	CPO SR	50	55	30	0	0	0	25	40	17
01-80-0-L	CREW SR	50	55	30	0	0	0	25	40	17
01-83-2-L	CPO SR	50	55	30	0	0	0	25	40	17
01-86-1-L	CREW SR	50	55	30	0	0	0	25	40	17
01-88-0-L	CREW SR	50	55	30	0	0	0	25	40	17
01-88-2-L	CREW SR	50	55	30	0	0	0	25	40	17
02-63-2-L	OFFICER SR	50	55	30	0	0	0	25	40	17
02-69-1-L	OFFICER SR	50	55	30	0	0	0	25	40	17
02-69-4-L	OFFICER SR	50	55	30	0	0	0	25	40	17
CUI=L5	(Crews Berthing) Frequency of EB=0.0008									
1-85-1-L	CREW SR	59	59	35	0	0	0	26	52	23
1-85-3-L	CREW SR	59	59	35	0	0	0	26	52	23
1-85-4-L	CREW SR	59	59	35	0	0	0	26	52	23
1-92-1-L	CREW SR	59	59	35	0	0	0	26	52	23
1-92-2-L	CREW SR	59	59	35	0	0	0	26	52	23
1-96-0-L	CREW SR	59	59	35	0	0	0	26	52	23
CUI=LL	(Wardroom/Mess/Lounge Areas) Frequency of EB=0.0008									
1-66-0-L	CREW MESS	31	34	18	0	0	0	39	48	23
1-77-2-L	CPO MESS & LOUNGE	31	34	18	0	0	0	39	48	23
1-77-3-L	CREW LOUNGE	31	34	18	0	0	0	39	48	23
01-60-1-L	WARDROOM MESSROOM & LOUNGE	31	34	18	0	0	0	39	48	23
CUI=LM	(Medical/Dental Spaces) Frequency of EB=0.0004									
01-68-1-L	MEDICAL TREATMENT ROOM	35	38	21	0	0	0	29	36	17
CUI=LP	(Passageway/Staircase/Vestibule) Frequency of EB=0.0001									
3-21-0-L	PASSAGE	79	79	71	0	0	0	62	68	55
2-21-0-L	PASSAGE	79	79	71	0	0	0	62	68	55
2-36-1-L	PASSAGE	79	79	71	0	0	0	62	68	55
2-39-1-L	PASSAGE	79	79	71	0	0	0	62	68	55
2-48-1-L	PASSAGE	79	79	71	0	0	0	62	68	55
2-53-1-L	VESTIBULE	86	86	77	0	0	0	62	68	55
2-57-0-L	PASSAGE	79	79	71	0	0	0	62	68	55
1-12-1A-L	PASSAGE	79	79	71	0	0	0	62	68	55
1-12-1B-L	PASSAGE	79	79	71	0	0	0	62	68	55
1-15-1-L	COMPANIONWAY	86	86	77	0	0	0	62	68	55
1-21-1-L	VESTIBULE	86	86	77	0	0	0	62	68	55
1-21-3-L	COMPANIONWAY	86	86	77	0	0	0	62	68	55
1-57-2-L	PASSAGE	79	79	71	0	0	0	62	68	55
1-59-2-L	COMPANIONWAY	86	86	77	0	0	0	62	68	55
1-66-2-L	COMPANIONWAY	86	86	77	0	0	0	62	68	55
1-82-0-L	PASSAGE	79	79	71	0	0	0	62	68	55
1-84-2-L	COMPANIONWAY	86	86	77	0	0	0	62	68	55
1-92-0-L	PASSAGE	79	79	71	0	0	0	62	68	55
01-60-0A-L	PASSAGE	79	79	71	0	0	0	62	68	55
01-60-0B-L	PASSAGE	79	79	71	0	0	0	62	68	55
01-60-0C-L	PASSAGE	79	79	71	0	0	0	62	68	55
01-66-2-L	PASSAGE	79	79	71	0	0	0	62	68	55
01-79-0A-L	PASSAGE	79	79	71	0	0	0	62	68	55
01-79-0B-L	PASSAGE	79	79	71	0	0	0	62	68	55
01-92-0-L	COMPANIONWAY	86	86	77	0	0	0	62	68	55

Table B.6.2 Probability of Flame Termination (At-Sea)

02-57-0A-L	PASSAGE	79	79	71	0	0	0	62	68	55
02-57-0B-L	PASSAGE	79	79	71	0	0	0	62	68	55
02-57-0C-L	PASSAGE	79	79	71	0	0	0	62	68	55
02-59-2-L	COMPANIONWAY	86	86	77	0	0	0	62	68	55
02-61-2-L	COMPANIONWAY	86	86	77	0	0	0	62	68	55
CUI=LW	(Sanitary Spaces) Frequency of EB=0.0002									
1-57-0-L	DECK WR & WC	92	92	73	0	0	0	31	34	27
1-57-4-Q	CHANGE ROOM	92	92	73	0	0	0	59	64	53
1-60-1-L	GALLEY WR & WC	92	92	73	0	0	0	31	34	27
1-82-1-L	CREW WR, WC & SH	92	92	73	0	0	0	31	34	27
1-82-3-L	CREW WR, WC & SH	92	92	73	0	0	0	31	34	27
1-82-4-L	CREW WR, WC & SH	92	92	73	0	0	0	31	34	27
1-96-1-L	CREW WR, WC & SH	92	92	73	0	0	0	31	34	27
1-97-4-L	CREW WR, WC & SH	92	92	73	0	0	0	31	34	27
1-98-1-L	CREW WR, WC & SH	92	92	73	0	0	0	31	34	27
01-57-4-L	CPO WR, WC, SH	92	92	73	0	0	0	31	34	27
01-71-2-L	CPO WR, WC, SH	92	92	73	0	0	0	31	34	27
01-74-1-L	MEDICAL TREATMENT WR, WC & SH	92	92	73	0	0	0	31	34	27
01-84-2-L	CREW WR, WC & SH	92	92	73	0	0	0	31	34	27
01-88-1-L	CREW WR, WC & SH	92	92	73	0	0	0	31	34	27
02-57-2-L	XO WR, WC, SH	92	92	73	0	0	0	31	34	27
02-63-1-L	CO WR, WC, SH	92	92	73	0	0	0	31	34	27
02-66-1-L	OFFICER WR, WC, SH	92	92	73	0	0	0	31	34	27
02-66-2-L	OFFICER WR, WC, SH	92	92	73	0	0	0	31	34	27
02-66-4-L	OFFICER WR, WC, SH	92	92	73	0	0	0	31	34	27
03-66-0-L	DECK WR & WC	92	92	73	0	0	0	31	34	27
CUI=QA	(Aux Machinery Spaces) Frequency of EB=0.0029									
4-82-0-E	AUXILIARY MACHINERY ROOM	50	50	35	70	70	35	14	15	10
2-21-2-Q	POTABLE WATER PUMP ROOM	50	50	35	0	0	0	13	14	9
2-48-2-E	SOR PUMP ROOM	50	50	35	52	52	26	13	14	9
2-49-0-E	SOR MACHINERY ROOM	50	50	35	52	52	26	13	14	9
2-57-4-E	WATER SUPPLY EQPT ROOM	50	50	35	0	0	0	13	14	9
1-18-1-Q	D.C. REPAIR LKR NO. 1	50	50	35	0	0	0	13	14	9
1-18-2-Q	AFFF STA.	50	50	35	0	0	0	10	11	7
1-74-2-Q	DC REPAIR LKR NO. 2	50	50	35	0	0	0	33	36	24
1-85-2-Q	AFFF STA.	50	50	35	0	0	0	22	24	16
CUI=QE	(Emergency Aux Generator Spaces) Frequency of EB=0.0204									
01-78-1-F	EMERGENCY GEN SERVICE TK	0	0	0	0	0	0	0	0	0
01-78-3-E	EMERGENCY GENERATOR ROOM	43	43	25	64	64	32	13	14	9
CUI=QF	(Fan Room) Frequency of EB=0.0004									
1-97-2-Q	FAN ROOM	66	52	39	0	0	0	55	100	41
02-73-0-Q	FAN ROOM	66	52	39	0	0	0	55	100	41
CUI=QG	(Galley/Pantry/Scullery) Frequency of EB=0.0026									
1-57-1-Q	GALLEY	79	79	47	0	0	0	26	36	20
1-66-1-Q	GALLEY ANNEX	79	79	47	0	0	0	26	36	20
1-66-3-Q	SCULLERY	79	79	47	0	0	0	46	64	36
01-57-0-Q	WARD ROOM PANTRY	79	79	47	0	0	0	26	36	20
02-85-0-Q	INCINERATOR ROOM	40	40	24	52	52	26	29	40	23
CUI=QL	(Laundry) Frequency of EB=0.0031									
1-105-2-Q	LAUNDRY	35	43	26	0	0	0	33	49	19

Table B.6.2 Probability of Flame Termination (At-Sea)

CUI=QO	(Office Spaces) Frequency of EB=0.0004									
1-71-2-Q	ENG LOG OFFICE & DC CENTRAL	27	32	16	0	0	0	29	36	17
01-68-0-Q	SHIP OFFICE	27	32	16	0	0	0	29	36	17
CUI=QS	(Shops) Frequency of EB=0.0018									
2-57-1-Q	MACHINE SHOP	39	42	23	0	0	0	33	39	19
2-59-1-Q	ELEC/ELEX WORKSHOP & STORERM	39	42	23	0	0	0	33	39	19
1-12-3-Q	BOATSWAIN SHOP	39	42	23	0	0	0	33	39	19
1-21-2-Q	ATON SHOP	39	42	23	0	0	0	33	39	19
CUI=TH	(Trunks/Hoists/Dumbwaiters) Frequency of EB=0.0001									
3-23-0-Q	CRANE PEDESTAL	98	100	58	0	0	0	9	10	5
1-19-2-T	ESC TRUNK	98	100	58	0	0	0	34	40	20
1-57-3-Q	DUMBWAITER TRUNK	98	100	58	0	0	0	34	40	20
1-80-1-E	VENT PLENUM	98	100	58	0	0	0	34	40	20
1-80-1-Q	VENT PLENUM	98	100	58	0	0	0	34	40	20
CUI=TU	(Stacks/Engine Uptakes) Frequency of EB=0.0013									
1-76-0-Q	MMR (UPTAKE)	19	20	11	0	0	0	0	0	0
03-76-0-Q	STACK	19	20	11	0	0	0	7	9	4
CUI=V	(Voids/Cofferdams) Frequency of EB=0.0001									
4-17-2-V	VOID	100	100	100	0	0	0	47	47	47
4-37-2-V	VOID	100	100	100	0	0	0	47	47	47
4-39-0-V	VOID	100	100	100	0	0	0	47	47	47
4-39-0A-V	VOID	100	100	100	0	0	0	47	47	47
4-39-0C-V	VOID	100	100	100	0	0	0	47	47	47
3-51-0-V	VOID	100	100	100	0	0	0	47	47	47
2-39-0-V	COFFERDAM	100	100	100	0	0	0	47	47	47
2-39-2-V	VOID	100	100	100	0	0	0	47	47	47
2-48-0-V	COFFERDAM	100	100	100	0	0	0	47	47	47
CUI=W	(Water Tank (empty)) Frequency of EB=0.0004									
4-21-0A-W	SW BALLAST TANK	100	100	100	0	0	0	47	47	47
4-21-0B-W	SW BALLAST TANK	100	100	100	0	0	0	47	47	47
4-21-0C-W	SW BALLAST TANK	100	100	100	0	0	0	47	47	47
4-30-3-W	SW BALLAST TANK	100	100	100	0	0	0	47	47	47
4-30-4-W	SW BALLAST TANK	100	100	100	0	0	0	47	47	47
4-48-0A-W	SW BALLAST TANK	100	100	100	0	0	0	47	47	47
4-48-0B-W	SW BALLAST TANK	100	100	100	0	0	0	47	47	47
4-48-0C-W	SW BALLAST TANK	100	100	100	0	0	0	47	47	47
4-57-0A-W	SW BALLAST TANK	100	100	100	0	0	0	47	47	47
4-57-0B-W	SW BALLAST TANK	100	100	100	0	0	0	47	47	47
4-57-0C-W	SW BALLAST TANK	100	100	100	0	0	0	47	47	47
4-80-0-W	SEA BAY	100	100	100	0	0	0	47	47	47
4-0-0-W	SW BALLAST TANK	100	100	100	0	0	0	47	47	47
4-6-0A-W	SW BALLAST TANK	100	100	100	0	0	0	47	47	47
4-6-0B-W	SW BALLAST TANK	100	100	100	0	0	0	47	47	47
4-6-0C-W	SW BALLAST TANK	100	100	100	0	0	0	47	47	47
2-25-1-WW	POTABLE WATER (CARGO)	100	100	100	0	0	0	47	47	47
2-25-2-W	POTABLE WATER (SHIP)	100	100	100	0	0	0	47	47	47

Table B.7 Fuel Loads

Plan ID	Compartment Name	Cellulosics (psf)	Plastics (psf)	Flam. Liq. (gal)	Total Fuel (kBTUs/sf)	Growth Model	Stack Ht. %	% Deck Occupied
CUI=AA	(Cargo Hold)							
2-30-0-AA	CARGO HOLD	2.0	10.0	0	176.0	1	10	50
CUI=AG	(Gear Locker)							
3-6-0-Q	CHAIN LOCKER SUMP	0.0	0.0	0	0.0	16	NA	0
2-6-1-Q	CHAIN LOCKER	0.0	2.3	0	36.8	16	NA	10
2-6-2-Q	CHAIN LOCKER	0.0	2.3	0	36.8	16	NA	10
1-77-1-A	CREW LOCKER	8.0	4.0	0	128.0	5	NA	75
1-82-2-Q	C.G. LKR W/ SINK	1.5	0.5	0	20.0	5	NA	75
01-70-2-Q	C.G. LKR	1.5	0.5	0	20.0	5	NA	75
01-85-2-Q	FOUL WEATHER GEAR LKR	8.0	4.0	0	128.0	12	NA	75
02-69-2-Q	CG LKR W/SINK	1.5	0.5	0	20.0	5	NA	75
02-75-1-Q	PFD & SURVIVAL SUIT LOCKER	2.0	6.0	0	112.0	12	NA	75
02-75-2-Q	PFD & SURVIVAL SUIT LOCKER	1.0	9.0	0	152.0	12	NA	75
CUI=AR	(Refrigerated Storage)							
1-60-2-A	CHILL STRM	0.5	0.5	0	12.0	16	NA	75
1-60-4-A	FREEZE STRM	0.5	0.5	0	12.0	16	NA	75
CUI=AS	(Storeroom)							
3-57-0-A	SUPPLY DEPT. STOREROOM NO. 2	6.0	2.0	1	80.4	5	NA	75
2-21-1-A	SUPPLY DEPT STOREROOM NO. 1	8.0	3.0	1	113.1	5	NA	75
2-50-1-A	ENGINEER STOREROOM	6.0	3.0	1	96.7	5	NA	75
2-57-2-A	SHIP STORE	10.0	2.0	1	113.6	6	NA	75
1-0-0-A	BOATSWAIN STOREROOM NO. 1	2.0	2.0	1	48.6	2	90	75
1-6-1-A	BOATSWAIN STOREROOM NO. 2	2.0	2.0	1	49.1	2	90	75
1-18-4-A	ATON STRM	4.0	2.0	1	65.1	5	NA	75
1-60-6A-A	DRY PROVISION STOREROOM	2.0	1.0	1	33.5	2	90	75
1-60-6B-A	DRY PROVISION STOREROOM	2.0	1.0	1	33.7	2	90	75
1-102-2-A	DECK GEAR STOREROOM	0.5	6.0	1	101.4	5	NA	75
CUI=C	(Ship Control/Communications)							
2-89-1-C	ENGINEERING CONTROL CENTER	2.0	3.0	0	64.0	7	NA	75
01-27-0-C	BUOY DECK CONTROL BOOTH	4.0	1.0	0	48.0	7	NA	75
02-66-0-C	RADIO ROOM	2.0	4.0	0	80.0	7	NA	75
03-56-0A-C	PILOT HOUSE	3.0	1.5	0	48.0	7	NA	75
03-56-0B-C	PILOT HOUSE (CHART AREA)	3.0	1.5	0	48.0	7	NA	75
03-66-01-C	ELEX, IC & GYRO ROOM	3.0	2.0	0	56.0	7	NA	75
CUI=EM	(Main Propulsion - Mechanical)							
4-12-0-E	BOWTHRUSTER MCHRY ROOM	0.7	1.5	10	32.5	13	NA	50
4-66-0-E	MAIN MACHINERY ROOM	2.0	2.0	30	51.3	13	NA	75
4-92-0-E	STERN THRUSTER MACHRY ROOM	0.2	0.3	3	7.8	13	NA	50
1-102-0-E	STEERING GEAR ROOM	0.2	1.0	25	27.6	13	NA	50
CUI=K	(Hazardous Material Storage)							
1-6-2-A	FLAM. LIQ. STOREROOM	1.0	0.2	35	43.5	1	90	75
CUI=L1	(Senior Officer's Cabin)							
02-57-0-L	CO CABIN	3.0	1.5	0	48.0	9	NA	50
02-57-1-L	CO SR	4.0	1.5	0	56.0	10	NA	50
02-57-4-L	XO SR	4.0	1.0	0	48.0	10	NA	50
CUI=L2	(Officer/CPO Quarters)							
01-57-2-L	CPO SR	5.0	2.5	0	80.0	10	NA	50
01-74-2-L	CPO SR	5.0	1.0	0	56.0	10	NA	50
01-80-0-L	CREW SR	5.0	1.0	0	56.0	10	NA	50
01-83-2-L	CPO SR	5.0	1.0	0	56.0	10	NA	50

Table B.7 Fuel Loads

Plan ID	Compartment Name	Cellulosics (psf)	Plastics (psf)	Flam. Liq. (gal)	Total Fuel (kBTUs/sf)	Growth Model	Stack Ht. %	% Deck Occupied
01-86-1-L	CREW SR	5.0	1.0	0	56.0	10	NA	50
01-88-0-L	CREW SR	5.0	1.0	0	56.0	10	NA	50
01-88-2-L	CREW SR	5.0	1.0	0	56.0	10	NA	50
02-63-2-L	OFFICER SR	5.0	1.0	0	56.0	10	NA	50
02-69-1-L	OFFICER SR	5.5	1.0	0	60.0	10	NA	50
02-69-4-L	OFFICER SR	5.0	1.0	0	56.0	10	NA	50
CUI=L5	(Crews Berthing)							
1-85-1-L	CREW SR	6.0	1.0	0	64.0	10	NA	50
1-85-3-L	CREW SR	6.0	1.0	0	64.0	10	NA	50
1-85-4-L	CREW SR	6.0	1.0	0	64.0	10	NA	50
1-92-1-L	CREW SR	6.0	1.0	0	64.0	10	NA	50
1-92-2-L	CREW SR	6.0	1.0	0	64.0	10	NA	50
1-96-0-L	CREW SR	6.0	1.0	0	64.0	10	NA	50
CUI=LL	(Wardroom/Mess/Lounge Areas)							
1-66-0-L	CREW MESS	1.5	1.0	0	28.0	9	NA	50
1-77-2-L	CPO MESS & LOUNGE	4.0	2.0	0	64.0	9	NA	50
1-77-3-L	CREW LOUNGE	4.0	2.0	0	64.0	9	NA	50
01-60-1-L	WARDROOM MESSROOM & LOUNGE	3.0	3.0	0	72.0	9	NA	50
CUI=LM	(Medical/Dental Spaces)							
01-68-1-L	MEDICAL TREATMENT ROOM	5.0	2.0	3	73.7	7	NA	75
CUI=LP	(Passageway/Staircase/Vestibule)							
3-21-0-L	PASSAGE	0.2	0.5	0	9.6	15	NA	25
2-21-0-L	PASSAGE	0.2	1.5	0	25.6	15	NA	25
2-36-1-L	PASSAGE	0.5	2.0	0	36.0	15	NA	25
2-39-1-L	PASSAGE	0.5	1.5	0	28.0	15	NA	25
2-48-1-L	PASSAGE	3.0	1.0	0	40.0	15	NA	25
2-53-1-L	VESTIBULE	0.2	1.5	0	25.6	15	NA	25
2-57-0-L	PASSAGE	0.5	2.0	0	36.0	15	NA	25
1-12-1A-L	PASSAGE	1.0	2.0	0	40.0	15	NA	25
1-12-1B-L	PASSAGE	1.0	2.0	0	40.0	15	NA	25
1-15-1-L	COMPANIONWAY	0.0	0.2	0	3.2	14	NA	25
1-21-1-L	VESTIBULE	0.2	1.5	0	25.6	15	NA	25
1-21-3-L	COMPANIONWAY	2.0	2.0	0	48.0	14	NA	25
1-57-2-L	PASSAGE	1.0	2.0	0	40.0	15	NA	25
1-59-2-L	COMPANIONWAY	0.2	1.0	0	17.6	14	NA	25
1-66-2-L	COMPANIONWAY	0.2	0.2	0	4.8	14	NA	25
1-82-0-L	PASSAGE	1.0	1.5	0	32.0	15	NA	25
1-84-2-L	COMPANIONWAY	0.5	1.5	0	28.0	14	NA	25
1-92-0-L	PASSAGE	0.2	1.5	0	25.6	15	NA	25
01-60-0A-L	PASSAGE	0.5	3.0	0	52.0	15	NA	25
01-60-0B-L	PASSAGE	0.5	1.5	0	28.0	15	NA	25
01-60-0C-L	PASSAGE	0.5	1.5	0	28.0	15	NA	25
01-66-2-L	PASSAGE	3.0	1.0	0	40.0	15	NA	25
01-79-0A-L	PASSAGE	0.5	1.5	0	28.0	15	NA	25
01-79-0B-L	PASSAGE	0.5	3.0	0	52.0	15	NA	25
01-92-0-L	COMPANIONWAY	0.0	0.2	0	3.2	14	NA	25
02-57-0A-L	PASSAGE	1.0	3.0	0	56.0	15	NA	25
02-57-0B-L	PASSAGE	0.5	1.5	0	28.0	15	NA	25
02-57-0C-L	PASSAGE	1.0	3.0	0	56.0	15	NA	25
02-59-2-L	COMPANIONWAY	0.0	0.2	0	3.2	14	NA	25

Table B.7 Fuel Loads

Plan ID	Compartment Name	Cellulosics (psf)	Plastics (psf)	Flam. Liq. (gal)	Total Fuel (kBTUs/sf)	Growth Model	Stack Ht. %	% Deck Occupied
02-61-2-L	COMPANIONWAY	0.0	0.2	0	3.2	14	NA	25
CUI=LW	(Sanitary Spaces)							
1-57-0-L	DECK WR & WC	0.2	0.1	0	3.2	16	NA	25
1-57-4-Q	CHANGE ROOM	2.0	2.0	0	48.0	12	NA	25
1-60-1-L	GALLEY WR & WC	0.2	0.1	0	3.2	16	NA	25
1-82-1-L	CREW WR, WC & SH	1.2	1.0	0	25.6	16	NA	25
1-82-3-L	CREW WR, WC & SH	1.2	1.0	0	25.6	16	NA	25
1-82-4-L	CREW WR, WC & SH	1.2	1.0	0	25.6	16	NA	25
1-96-1-L	CREW WR, WC & SH	1.2	1.0	0	25.6	16	NA	25
1-97-4-L	CREW WR, WC & SH	1.2	1.0	0	25.6	16	NA	25
1-98-1-L	CREW WR, WC & SH	1.2	1.0	0	25.6	16	NA	25
01-57-4-L	CPO WR, WC, SH	1.2	1.0	0	25.6	16	NA	25
01-71-2-L	CPO WR, WC, SH	1.2	1.0	0	25.6	16	NA	25
01-74-1-L	MEDICAL TREATMENT WR, WC & SH	1.2	1.0	0	25.6	16	NA	25
01-84-2-L	CREW WR, WC & SH	1.2	1.0	0	25.6	16	NA	25
01-88-1-L	CREW WR, WC & SH	1.2	1.0	0	25.6	16	NA	25
02-57-2-L	XO WR, WC, SH	1.2	1.0	0	25.6	16	NA	25
02-63-1-L	CO WR, WC, SH	1.2	1.0	0	25.6	16	NA	25
02-66-1-L	OFFICER WR, WC, SH	1.2	1.0	0	25.6	16	NA	25
02-66-2-L	OFFICER WR, WC, SH	1.2	1.0	0	25.6	16	NA	25
02-66-4-L	OFFICER WR, WC, SH	1.2	1.0	0	25.6	16	NA	25
03-66-0-L	DECK WR & WC	1.5	0.3	0	16.8	16	NA	25
CUI=QA	(Aux Machinery Spaces)							
4-82-0-E	AUXILIARY MACHINERY ROOM	2.0	2.0	10	49.7	13	NA	50
2-21-2-Q	POTABLE WATER PUMP ROOM	0.5	1.0	5	23.3	13	NA	50
2-48-2-E	SOR PUMP ROOM	2.0	1.6	5	44.0	13	NA	50
2-49-0-E	SOR MACHINERY ROOM	0.2	2.0	7	37.9	13	NA	50
2-57-4-E	WATER SUPPLY EQPT ROOM	2.0	1.5	5	43.4	13	NA	50
1-18-1-Q	D.C. REPAIR LKR NO. 1	3.0	2.0	0	56.0	13	NA	50
1-18-2-Q	AFFF STA.	1.0	1.0	5	41.4	13	NA	50
1-74-2-Q	DC REPAIR LKR NO. 2	3.0	1.0	0	40.0	5	NA	75
1-85-2-Q	AFFF STA.	1.0	1.5	5	48.0	13	NA	50
CUI=QE	(Emergency Aux Generator Spaces)							
01-78-1-F	EMERGENCY GEN SERVICE TK	0.0	0.0	0	0.0	16	NA	0
01-78-3-E	EMERGENCY GENERATOR ROOM	0.5	2.0	3	38.0	13	NA	50
CUI=QF	(Fan Room)							
1-97-2-Q	FAN ROOM	0.2	0.2	0	4.8	13	NA	25
02-73-0-Q	FAN ROOM	1.0	2.0	0	40.0	13	NA	25
CUI=QG	(Galley/Pantry/Scullery)							
1-57-1-Q	GALLEY	0.3	0.1	1	4.4	16	NA	50
1-66-1-Q	GALLEY ANNEX	0.2	0.1	1	4.7	16	NA	50
1-66-3-Q	SCULLERY	0.3	0.2	1	7.0	16	NA	50
01-57-0-Q	WARD ROOM PANTRY	0.2	0.2	1	6.0	13	NA	50
02-85-0-Q	INCINERATOR ROOM	3.0	2.5	1	65.3	5	NA	50
CUI=QL	(Laundry)							
1-105-2-Q	LAUNDRY	2.0	0.5	0	24.0	12	NA	75
CUI=QO	(Office Spaces)							
1-71-2-Q	ENG LOG OFFICE & DC CENTRAL	3.0	1.0	0	40.0	7	NA	75
01-68-0-Q	SHIP OFFICE	7.0	3.0	0	104.0	7	NA	75
CUI=QS	(Shops)							

Table B.7 Fuel Loads

Plan ID	Compartment Name	Cellulosics (psf)	Plastics (psf)	Flam. Liq. (gal)	Total Fuel (kBTUs/sf)	Growth Model	Stack Ht. %	% Deck Occupied
2-57-1-Q	MACHINE SHOP	2.0	2.5	0	56.0	7	NA	75
2-59-1-Q	ELEC/ELEX WORKSHOP & STORERM	3.0	2.0	0	56.0	7	NA	75
1-12-3-Q	BOATSWAIN SHOP	1.0	4.0	0	72.0	5	NA	75
1-21-2-Q	ATON SHOP	2.0	3.0	0	64.0	13	NA	75
CUI=TH	(Trunks/Hoists/Dumbwaiters)							
3-23-0-Q	CRANE PEDESTAL	1.0	0.5	0	16.0	16	NA	50
1-19-2-T	ESC TRUNK	1.0	0.5	0	16.0	16	NA	10
1-57-3-Q	DUMBWAITER TRUNK	1.0	0.5	0	16.0	16	NA	10
1-80-1-E	VENT PLENUM	1.0	0.5	0	16.0	16	NA	10
1-80-1-Q	VENT PLENUM	1.0	0.5	0	16.0	16	NA	10
CUI=TU	(Stacks/Engine Uptakes)							
1-76-0-Q	MMR (UPTAKE)	2.0	0.9	0	30.4	13	NA	25
03-76-0-Q	STACK	2.0	0.9	0	30.4	13	NA	25
CUI=V	(Voids/Cofferdams)							
4-17-2-V	VOID	0.0	0.0	0	0.0	16	NA	0
4-37-2-V	VOID	0.0	0.0	0	0.0	16	NA	0
4-39-0-V	VOID	0.0	0.0	0	0.0	16	NA	0
4-39-0A-V	VOID	0.0	0.0	0	0.0	16	NA	0
4-39-0C-V	VOID	0.0	0.0	0	0.0	16	NA	0
3-51-0-V	VOID	0.0	0.0	0	0.0	16	NA	0
2-39-0-V	COFFERDAM	0.0	0.0	0	0.0	16	NA	0
2-39-2-V	VOID	0.0	0.0	0	0.0	16	NA	0
2-48-0-V	COFFERDAM	0.0	0.0	0	0.0	16	NA	0
CUI=W	(Water Tank (empty))							
4-21-0A-W	SW BALLAST TANK	0.0	0.0	0	0.0	16	NA	0
4-21-0B-W	SW BALLAST TANK	0.0	0.0	0	0.0	16	NA	0
4-21-0C-W	SW BALLAST TANK	0.0	0.0	0	0.0	16	NA	0
4-30-3-W	SW BALLAST TANK	0.0	0.0	0	0.0	16	NA	0
4-30-4-W	SW BALLAST TANK	0.0	0.0	0	0.0	16	NA	0
4-48-0A-W	SW BALLAST TANK	0.0	0.0	0	0.0	16	NA	0
4-48-0B-W	SW BALLAST TANK	0.0	0.0	0	0.0	16	NA	0
4-48-0C-W	SW BALLAST TANK	0.0	0.0	0	0.0	16	NA	0
4-57-0A-W	SW BALLAST TANK	0.0	0.0	0	0.0	16	NA	0
4-57-0B-W	SW BALLAST TANK	0.0	0.0	0	0.0	16	NA	0
4-57-0C-W	SW BALLAST TANK	0.0	0.0	0	0.0	16	NA	0
4-80-0-W	SEA BAY	0.0	0.0	0	0.0	16	NA	0
4-0-0-W	SW BALLAST TANK	0.0	0.0	0	0.0	16	NA	0
4-6-0A-W	SW BALLAST TANK	0.0	0.0	0	0.0	16	NA	0
4-6-0B-W	SW BALLAST TANK	0.0	0.0	0	0.0	16	NA	0
4-6-0C-W	SW BALLAST TANK	0.0	0.0	0	0.0	16	NA	0
2-25-1-WW	POTABLE WATER (CARGO)	0.0	0.0	0	0.0	16	NA	0
2-25-2-W	POTABLE WATER (SHIP)	0.0	0.0	0	0.0	16	NA	0

Table B.8 Fire Growth Models, Rates, and FRI Times

Plan ID	Compartment Name	Growth Model	Alpha kW/sec ²	Max Q kW	FRI Time (min)			Post- FRI Q (kW)		
					X	Y	Z	X	Y	Z
CUI=AA	(Cargo Hold)									
2-30-0-AA	CARGO HOLD	1	0.100	34611	4	4	4	1800	82	82
CUI=AG	(Gear Locker)									
3-6-0-Q	CHAIN LOCKER SUMP	16	0.001	0	999	999	999	0	0	0
2-6-1-Q	CHAIN LOCKER	16	0.001	8	999	999	999	8	8	8
2-6-2-Q	CHAIN LOCKER	16	0.001	8	999	999	999	8	8	8
1-77-1-A	CREW LOCKER	5	0.100	104	20	20	27	104	104	6
1-82-2-Q	C.G. LKR W/ SINK	5	0.400	42	999	999	999	42	42	42
01-70-2-Q	C.G. LKR	5	0.400	45	999	999	999	45	45	45
01-85-2-Q	FOUL WEATHER GEAR LKR	12	0.100	4867	1	1	1	117	117	117
02-69-2-Q	CG LKR W/SINK	5	0.400	42	999	999	999	42	42	42
02-75-1-Q	PFD & SURVIVAL SUIT LOCKER	12	0.100	7808	2	2	2	2165	2165	0
02-75-2-Q	PFD & SURVIVAL SUIT LOCKER	12	0.100	10596	2	2	2	2165	2165	0
CUI=AR	(Refrigerated Storage)									
1-60-2-A	CHILL STRM	16	0.001	26	999	999	999	6	6	6
1-60-4-A	FREEZE STRM	16	0.001	26	999	999	999	6	6	6
CUI=AS	(Storeroom)									
3-57-0-A	SUPPLY DEPT. STOREROOM NO. 2	5	0.100	1296	5	5	5	1296	1296	1296
2-21-1-A	SUPPLY DEPT STOREROOM NO. 1	5	0.100	509	6	6	6	509	509	509
2-50-1-A	ENGINEER STOREROOM	5	0.100	819	4	4	4	819	819	819
2-57-2-A	SHIP STORE	6	0.010	48424	4	4	4	21547	21547	18434
1-0-0-A	BOATSWAIN STOREROOM NO. 1	2	0.010	24934	6	6	6	1093	26	26
1-6-1-A	BOATSWAIN STOREROOM NO. 2	2	0.010	14906	5	5	5	14906	14906	14906
1-18-4-A	ATON STRM	5	0.100	531	11	11	11	531	531	1
1-60-6A-A	DRY PROVISION STOREROOM	2	0.010	10621	4	4	4	10621	10621	10621
1-60-6B-A	DRY PROVISION STOREROOM	2	0.010	9441	5	5	5	9441	9441	9441
1-102-2-A	DECK GEAR STOREROOM	5	0.100	400	10	10	10	400	106	106
CUI=C	(Ship Control/Communications)									
2-89-1-C	ENGINEERING CONTROL CENTER	7	0.010	23746	6	6	6	9404	9404	2930
01-27-0-C	BUOY DECK CONTROL BOOTH	7	0.010	2246	3	3	3	1575	1575	6
02-66-0-C	RADIO ROOM	7	0.010	14196	5	5	5	198	198	198
03-56-0A-C	PILOT HOUSE	7	0.010	42331	9	9	9	24379	24379	20684
03-56-0B-C	PILOT HOUSE (CHART AREA)	7	0.010	9898	5	5	5	9898	9898	9898
03-66-01-C	ELEX, IC & GYRO ROOM	7	0.010	7753	5	5	5	69	69	69
CUI=EM	(Main Propulsion - Mechanical)									
4-12-0-E	BOWTHRUSTER MCHRY ROOM	13	0.200	67870	3	3	3	1462	1462	1462
4-66-0-E	MAIN MACHINERY ROOM	13	0.200	437314	3	3	3	45048	45048	34792
4-92-0-E	STERN THRUSTER MACHRY ROOM	13	0.200	9728	2	2	2	5090	333	333
1-102-0-E	STEERING GEAR ROOM	13	0.200	36142	2	2	2	1677	34	34
CUI=K	(Hazardous Material Storage)									
1-6-2-A	FLAM. LIQ. STOREROOM	1	0.100	55853	2	2	2	16	16	16
CUI=L1	(Senior Officer's Cabin)									
02-57-0-L	CO CABIN	9	0.300	580	25	25	26	580	580	353
02-57-1-L	CO SR	10	0.100	248	999	999	999	248	248	248
02-57-4-L	XO SR	10	0.100	213	31	31	31	213	213	213
CUI=L2	(Officer/CPO Quarters)									
01-57-2-L	CPO SR	10	0.100	160	999	999	999	160	160	160
01-74-2-L	CPO SR	10	0.100	206	999	999	999	206	206	206
01-80-0-L	CREW SR	10	0.100	146	999	999	999	146	146	146
01-83-2-L	CPO SR	10	0.100	175	999	999	999	175	175	175
01-86-1-L	CREW SR	10	0.100	135	999	999	999	135	135	135
01-88-0-L	CREW SR	10	0.100	129	999	999	999	129	129	129
01-88-2-L	CREW SR	10	0.100	150	999	999	999	150	150	150
02-63-2-L	OFFICER SR	10	0.100	219	999	999	999	219	219	219

Table B.8 Fire Growth Models, Rates, and FRI Times

Plan ID	Compartment Name	Growth Model	Alpha kW/sec ²	Max Q kW	FRI Time (min)			Post-FRI Q (kW)		
					X	Y	Z	X	Y	Z
02-69-1-L	OFFICER SR	10	0.100	248	999	999	999	248	248	248
02-69-4-L	OFFICER SR	10	0.100	248	999	999	999	248	248	248
CUI=L5	(Crews Berthing)									
1-85-1-L	CREW SR	10	0.100	225	999	999	999	225	225	225
1-85-3-L	CREW SR	10	0.100	298	32	32	33	298	298	298
1-85-4-L	CREW SR	10	0.100	313	999	999	999	313	313	313
1-92-1-L	CREW SR	10	0.100	263	999	999	999	263	263	263
1-92-2-L	CREW SR	10	0.100	257	999	999	999	257	257	257
1-96-0-L	CREW SR	10	0.100	248	999	999	999	248	248	248
CUI=LL	(Wardroom/Mess/Lounge Areas)									
1-66-0-L	CREW MESS	9	0.200	625	999	999	999	625	625	625
1-77-2-L	CPO MESS & LOUNGE	9	0.300	375	999	999	999	177	177	177
1-77-3-L	CREW LOUNGE	9	0.300	375	21	21	21	375	375	295
01-60-1-L	WARDROOM MESSROOM & LOUNGE	9	0.300	540	999	999	999	274	274	274
CUI=LM	(Medical/Dental Spaces)									
01-68-1-L	MEDICAL TREATMENT ROOM	7	0.010	19890	5	5	5	2974	2974	272
CUI=LP	(Passageway/Staircase/Vestibule)									
3-21-0-L	PASSAGE	15	0.010	43	999	999	999	23	23	23
2-21-0-L	PASSAGE	15	0.010	220	999	999	999	220	220	220
2-36-1-L	PASSAGE	15	0.010	74	999	999	999	74	12	12
2-39-1-L	PASSAGE	15	0.010	195	999	999	999	195	5	5
2-48-1-L	PASSAGE	15	0.010	230	999	999	999	230	230	230
2-53-1-L	VESTIBULE	15	0.010	77	999	999	999	77	75	75
2-57-0-L	PASSAGE	15	0.010	414	999	999	999	414	414	414
1-12-1A-L	PASSAGE	15	0.010	200	999	999	999	200	200	200
1-12-1B-L	PASSAGE	15	0.010	44	999	999	999	44	44	44
1-15-1-L	COMPANIONWAY	14	0.010	8	999	999	999	6	6	6
1-21-1-L	VESTIBULE	15	0.010	69	999	999	999	69	69	7
1-21-3-L	COMPANIONWAY	14	0.010	373	13	14	14	373	6	6
1-57-2-L	PASSAGE	15	0.010	265	999	999	999	265	265	61
1-59-2-L	COMPANIONWAY	14	0.010	62	999	999	999	62	62	62
1-66-2-L	COMPANIONWAY	14	0.010	22	999	999	999	22	22	22
1-82-0-L	PASSAGE	15	0.010	272	999	999	999	272	272	272
1-84-2-L	COMPANIONWAY	14	0.010	118	999	999	999	118	118	118
1-92-0-L	PASSAGE	15	0.010	296	999	999	999	296	296	296
01-60-0A-L	PASSAGE	15	0.010	286	999	999	999	286	286	286
01-60-0B-L	PASSAGE	15	0.010	164	999	999	999	164	164	164
01-60-0C-L	PASSAGE	15	0.010	126	999	999	999	126	126	126
01-66-2-L	PASSAGE	15	0.010	198	999	999	999	198	198	198
01-79-0A-L	PASSAGE	15	0.010	224	999	999	999	224	224	224
01-79-0B-L	PASSAGE	15	0.010	260	999	999	999	260	260	260
01-92-0-L	COMPANIONWAY	14	0.010	10	999	999	999	10	10	10
02-57-0A-L	PASSAGE	15	0.010	336	33	33	33	336	336	336
02-57-0B-L	PASSAGE	15	0.010	56	999	999	999	56	56	56
02-57-0C-L	PASSAGE	15	0.010	386	999	999	999	386	386	386
02-59-2-L	COMPANIONWAY	14	0.010	4	999	999	999	4	4	4
02-61-2-L	COMPANIONWAY	14	0.010	13	999	999	999	13	13	13
CUI=LW	(Sanitary Spaces)									
1-57-0-L	DECK WR & WC	16	0.001	2	999	999	999	2	2	2
1-57-4-Q	CHANGE ROOM	12	0.100	2129	2	2	2	2129	2129	20
1-60-1-L	GALLEY WR & WC	16	0.001	2	999	999	999	2	2	2
1-82-1-L	CREW WR, WC & SH	16	0.001	23	999	999	999	23	23	23
1-82-3-L	CREW WR, WC & SH	16	0.001	23	999	999	999	23	23	23
1-82-4-L	CREW WR, WC & SH	16	0.001	26	999	999	999	26	26	26

Table B.8 Fire Growth Models, Rates, and FRI Times

Plan ID	Compartment Name	Growth Model	Alpha kW/sec ²	Max Q kW	FRI Time (min)			Post- FRI Q (kW)		
					X	Y	Z	X	Y	Z
1-96-1-L	CREW WR, WC & SH	16	0.001	24	999	999	999	24	24	24
1-97-4-L	CREW WR, WC & SH	16	0.001	28	999	999	999	28	28	28
1-98-1-L	CREW WR, WC & SH	16	0.001	25	999	999	999	25	25	25
01-57-4-L	CPO WR, WC, SH	16	0.001	24	999	999	999	24	24	24
01-71-2-L	CPO WR, WC, SH	16	0.001	24	999	999	999	24	24	24
01-74-1-L	MEDICAL TREATMENT WR, WC & SH	16	0.001	19	999	999	999	19	19	19
01-84-2-L	CREW WR, WC & SH	16	0.001	27	999	999	999	27	27	27
01-88-1-L	CREW WR, WC & SH	16	0.001	24	999	999	999	24	24	24
02-57-2-L	XO WR, WC, SH	16	0.001	16	999	999	999	16	16	16
02-63-1-L	CO WR, WC, SH	16	0.001	26	999	999	999	26	26	26
02-66-1-L	OFFICER WR, WC, SH	16	0.001	25	999	999	999	25	25	25
02-66-2-L	OFFICER WR, WC, SH	16	0.001	15	999	999	999	15	15	15
02-66-4-L	OFFICER WR, WC, SH	16	0.001	19	999	999	999	19	19	19
03-66-0-L	DECK WR & WC	16	0.001	6	999	999	999	6	6	6
CUI=QA	(Aux Machinery Spaces)									
4-82-0-E	AUXILIARY MACHINERY ROOM	13	0.200	184640	3	3	3	8899	8899	2669
2-21-2-Q	POTABLE WATER PUMP ROOM	13	0.200	20956	2	2	2	246	246	246
2-48-2-E	SOR PUMP ROOM	13	0.200	57760	2	2	2	1136	98	98
2-49-0-E	SOR MACHINERY ROOM	13	0.200	37184	2	2	2	62	62	62
2-57-4-E	WATER SUPPLY EQPT ROOM	13	0.200	38920	2	2	2	137	137	137
1-18-1-Q	D.C. REPAIR LKR NO. 1	13	0.200	16178	2	2	2	0	0	0
1-18-2-Q	AFFF STA.	13	0.200	6016	1	1	1	6016	6016	6016
1-74-2-Q	DC REPAIR LKR NO. 2	5	0.400	110	999	999	999	6	6	6
1-85-2-Q	AFFF STA.	13	0.200	8000	1	1	1	8000	8000	8000
CUI=QE	(Emergency Aux Generator Spaces)									
01-78-1-F	EMERGENCY GEN SERVICE TK	16	0.001	0	999	999	999	0	0	0
01-78-3-E	EMERGENCY GENERATOR ROOM	13	0.200	35520	2	2	2	4404	1783	1783
CUI=QF	(Fan Room)									
1-97-2-Q	FAN ROOM	13	0.200	720	2	2	2	6	6	6
02-73-0-Q	FAN ROOM	13	0.200	16800	2	2	2	1575	1575	6
CUI=QG	(Galley/Pantry/Scullery)									
1-57-1-Q	GALLEY	16	0.001	46	999	999	999	46	46	46
1-66-1-Q	GALLEY ANNEX	16	0.001	10	999	999	999	10	10	10
1-66-3-Q	SCULLERY	16	0.001	18	999	999	999	18	18	18
01-57-0-Q	WARD ROOM PANTRY	13	0.200	2984	2	2	2	414	414	414
02-85-0-Q	INCINERATOR ROOM	5	0.100	288	24	24	26	288	288	57
CUI=QL	(Laundry)									
1-105-2-Q	LAUNDRY	12	0.100	3917	2	2	2	30	30	30
CUI=QO	(Office Spaces)									
1-71-2-Q	ENG LOG OFFICE & DC CENTRAL	7	0.010	5265	5	5	5	204	204	204
01-68-0-Q	SHIP OFFICE	7	0.010	17238	5	5	5	421	421	421
CUI=QS	(Shops)									
2-57-1-Q	MACHINE SHOP	7	0.010	15848	6	6	6	41	41	41
2-59-1-Q	ELEC/ELEX WORKSHOP & STORERM	7	0.010	9555	5	5	5	34	34	34
1-12-3-Q	BOATSWAIN SHOP	5	0.100	523	11	11	11	23	23	23
1-21-2-Q	ATON SHOP	13	0.200	63360	2	2	2	3692	3692	28
CUI=TH	(Trunks/Hoists/Dumbwaiters)									
3-23-0-Q	CRANE PEDESTAL	16	0.001	32	999	999	999	2	2	2
1-19-2-T	ESC TRUNK	16	0.001	1	999	999	999	1	1	1
1-57-3-Q	DUMBWAITER TRUNK	16	0.001	1	999	999	999	1	1	1
1-80-1-E	VENT PLENUM	16	0.001	2	999	999	999	2	2	2
1-80-1-Q	VENT PLENUM	16	0.001	2	999	999	999	2	2	2
CUI=TU	(Stacks/Engine Uptakes)									
1-76-0-Q	MMR (UPTAKE)	13	0.200	10944	2	2	2	10944	10944	10944

Table B.8 Fire Growth Models, Rates, and FRI Times

Plan ID	Compartment Name	Growth Model	Alpha kW/sec ²	Max Q kW	FRI Time (min)			Post-FRI Q (kW)		
					X	Y	Z	X	Y	Z
03-76-0-Q	STACK	13	0.200	16416	2	2	2	1385	1385	1385
CUI=V	(Voids/Cofferdams)									
4-17-2-V	VOID	16	0.001	0	999	999	999	0	0	0
4-37-2-V	VOID	16	0.001	0	999	999	999	0	0	0
4-39-0-V	VOID	16	0.001	0	999	999	999	0	0	0
4-39-0A-V	VOID	16	0.001	0	999	999	999	0	0	0
4-39-0C-V	VOID	16	0.001	0	999	999	999	0	0	0
3-51-0-V	VOID	16	0.001	0	999	999	999	0	0	0
2-39-0-V	COFFERDAM	16	0.001	0	999	999	999	0	0	0
2-39-2-V	VOID	16	0.001	0	999	999	999	0	0	0
2-48-0-V	COFFERDAM	16	0.001	0	999	999	999	0	0	0
CUI=W	(Water Tank (empty))									
4-21-0A-W	SW BALLAST TANK	16	0.001	0	999	999	999	0	0	0
4-21-0B-W	SW BALLAST TANK	16	0.001	0	999	999	999	0	0	0
4-21-0C-W	SW BALLAST TANK	16	0.001	0	999	999	999	0	0	0
4-30-3-W	SW BALLAST TANK	16	0.001	0	999	999	999	0	0	0
4-30-4-W	SW BALLAST TANK	16	0.001	0	999	999	999	0	0	0
4-48-0A-W	SW BALLAST TANK	16	0.001	0	999	999	999	0	0	0
4-48-0B-W	SW BALLAST TANK	16	0.001	0	999	999	999	0	0	0
4-48-0C-W	SW BALLAST TANK	16	0.001	0	999	999	999	0	0	0
4-57-0A-W	SW BALLAST TANK	16	0.001	0	999	999	999	0	0	0
4-57-0B-W	SW BALLAST TANK	16	0.001	0	999	999	999	0	0	0
4-57-0C-W	SW BALLAST TANK	16	0.001	0	999	999	999	0	0	0
4-80-0-W	SEA BAY	16	0.001	0	999	999	999	0	0	0
4-0-0-W	SW BALLAST TANK	16	0.001	0	999	999	999	0	0	0
4-6-0A-W	SW BALLAST TANK	16	0.001	0	999	999	999	0	0	0
4-6-0B-W	SW BALLAST TANK	16	0.001	0	999	999	999	0	0	0
4-6-0C-W	SW BALLAST TANK	16	0.001	0	999	999	999	0	0	0
2-25-1-WW	POTABLE WATER (CARGO)	16	0.001	0	999	999	999	0	0	0
2-25-2-W	POTABLE WATER (SHIP)	16	0.001	0	999	999	999	0	0	0

Appendix C

WLB (R) Fire Safety Analysis Results

The various output data produced in the performance of a fire safety analysis on the U. S. Coast Guard Seagoing Buoy Tender replacement (WLB (R)) class of cutter using SAFE is documented in Appendices C and D. In Appendix C the baseline analysis results (post-ship visit) are presented, in Appendix D the preliminary baseline results (pre-ship visit) are presented.

The following is an index of the tables contained in this appendix.

C.1	Individual Target Output Option Results	
C.1.1	XRAY, In-Port, I, A, & M	C-2
C.1.2	XRAY, In-Port, I & A	C-3
C.1.3	XRAY, In-Port, I & M	C-4
C.1.4	XRAY, In-Port, I	C-5
C.1.5	YOKE, In-Port, I, A, & M	C-6
C.1.6	YOKE, In-Port, I & A	C-7
C.1.7	YOKE, In-Port, I & M	C-8
C.1.8	YOKE, In-Port, I	C-9
C.1.9	YOKE, At Sea, I, A, & M	C-10
C.1.10	YOKE, At Sea, I & A	C-11
C.1.11	YOKE, At Sea, I & M	C-12
C.1.12	YOKE, At Sea, I	C-13
C.2	Barrier Output Option Results	
C.2	Barrier Output Option - Summary Level Report	C-14
C.3	Path Output Option Results - Summary Level Report	
C.3.1	Room of Origin: 4-66-0-E	C-24
C.3.2	Room of Origin: 4-82-0-E	C-26
C.3.3	Room of Origin: 4-12-0-E	C-28
C.3.4	Room of Origin: 2-30-0-AA	C-29
C.3.5	Room of Origin: 1-85-3-L	C-30
C.4	Path Output Option Results - Detail Level Report	
C.4.1	Room of Origin: 4-66-0-E	C-31
C.4.2	Room of Origin: 4-82-0-E	C-53
C.4.3	Room of Origin: 4-12-0-E	C-74
C.4.4	Room of Origin: 2-30-0-AA	C-77
C.4.5	Room of Origin: 1-85-3-L	C-78

Table C.1.1

Run 24-152

Readiness Condition X-RAY
Configuration Passive, Automatic and Manual
Case Worst
Assumed Location In-Port
Run Time 60 minutes

Target Compartment	Magnitude/Frequency -of Acceptable Loss-	Relative Frequency of Loss FFS	Relative Loss Factor (RLF)
1-66-0-L	2 24 years	0.0182	0.4368
01-68-0-Q	2 22 years	0.0192	0.4227
03-76-0-Q	2 21 years	0.0174	0.3660
01-68-1-L	2 22 years	0.0146	0.3218
1-66-1-Q	2 26 years	0.0085	0.2217
02-66-0-C	2 26 years	0.0083	0.2152
01-78-3-E	2 24 years	0.0089	0.2144
1-76-0-Q	3 16 years	0.0128	0.2052
4-66-0-E	2 26 years	0.0076	0.1972
1-71-2-Q	2 22 years	0.0085	0.1867
2-89-1-C	2 24 years	0.0070	0.1678
2-57-4-E	2 22 years	0.0072	0.1576
1-102-0-E	2 26 years	0.0054	0.1396
4-92-0-E	2 24 years	0.0048	0.1163
4-82-0-E	2 22 years	0.0052	0.1154
03-56-0B-C	2 26 years	0.0043	0.1113
02-73-0-Q	2 22 years	0.0050	0.1109
2-59-1-Q	2 20 years	0.0054	0.1087
2-57-1-Q	2 20 years	0.0052	0.1034
1-85-2-Q	2 24 years	0.0037	0.0883
1-18-2-Q	2 24 years	0.0035	0.0849
1-74-2-Q	2 24 years	0.0032	0.0775
1-60-6A-A	3 13 years	0.0055	0.0720
1-60-6B-A	3 13 years	0.0054	0.0699
4-12-0-E	2 24 years	0.0029	0.0686
1-21-2-Q	2 23 years	0.0028	0.0652
2-21-2-Q	2 24 years	0.0025	0.0605
1-60-4-A	2 23 years	0.0026	0.0605
1-60-2-A	2 23 years	0.0026	0.0605
03-66-01-C	2 24 years	0.0024	0.0581
1-66-3-Q	2 26 years	0.0019	0.0499
2-48-2-E	2 23 years	0.0019	0.0435
03-56-0A-C	2 26 years	0.0016	0.0406
2-57-2-A	3 13 years	0.0029	0.0383
1-18-1-Q	2 24 years	0.0014	0.0328
1-12-3-Q	2 20 years	0.0014	0.0277
02-75-2-Q	3 17 years	0.0011	0.0187
1-6-2-A	1 30 years	0.0004	0.0128
02-75-1-Q	3 17 years	0.0007	0.0121
01-57-0-Q	2 26 years	0.0004	0.0112
1-6-1-A	3 13 years	0.0004	0.0056
2-49-0-E	2 23 years	0.0001	0.0030

Table C.1.2

Run 24-153

Readiness Condition X-RAY
Configuration Passive and Automatic
Case Worst
Assumed Location In-Port
Run Time 60 minutes

Target Compartment	Magnitude/Frequency -of Acceptable Loss-	Relative Frequency of Loss FFS	Relative Loss Factor (RLF)
01-68-0-Q	2 22 years	0.0435	0.9567
1-66-0-L	2 24 years	0.0362	0.8683
01-68-1-L	2 22 years	0.0366	0.8060
02-66-0-C	2 26 years	0.0247	0.6424
03-76-0-Q	2 21 years	0.0257	0.5387
1-66-1-Q	2 26 years	0.0173	0.4487
02-73-0-Q	2 22 years	0.0200	0.4396
03-56-0B-C	2 26 years	0.0155	0.4037
1-71-2-Q	2 22 years	0.0160	0.3523
01-78-3-E	2 24 years	0.0127	0.3037
1-76-0-Q	3 16 years	0.0166	0.2658
2-89-1-C	2 24 years	0.0102	0.2440
4-66-0-E	2 26 years	0.0093	0.2425
2-57-4-E	2 22 years	0.0095	0.2087
2-59-1-Q	2 20 years	0.0085	0.1699
2-57-1-Q	2 20 years	0.0082	0.1636
1-60-6B-A	3 13 years	0.0126	0.1634
1-60-4-A	2 23 years	0.0068	0.1570
1-60-2-A	2 23 years	0.0068	0.1570
1-102-0-E	2 26 years	0.0058	0.1518
4-82-0-E	2 22 years	0.0065	0.1438
1-74-2-Q	2 24 years	0.0059	0.1421
4-92-0-E	2 24 years	0.0057	0.1360
1-60-6A-A	3 13 years	0.0097	0.1263
03-66-01-C	2 24 years	0.0052	0.1247
1-85-2-Q	2 24 years	0.0051	0.1223
1-66-3-Q	2 26 years	0.0039	0.1015
03-56-0A-C	2 26 years	0.0038	0.0999
1-18-2-Q	2 24 years	0.0041	0.0991
1-21-2-Q	2 23 years	0.0038	0.0870
4-12-0-E	2 24 years	0.0033	0.0784
2-21-2-Q	2 24 years	0.0030	0.0719
1-97-2-Q	2 22 years	0.0031	0.0678
2-48-2-E	2 23 years	0.0029	0.0657
2-57-2-A	3 13 years	0.0044	0.0570
1-12-3-Q	2 20 years	0.0023	0.0467
1-18-1-Q	2 24 years	0.0019	0.0457
02-75-2-Q	3 17 years	0.0019	0.0330
1-6-2-A	1 30 years	0.0007	0.0211
02-75-1-Q	3 17 years	0.0009	0.0145
01-57-0-Q	2 26 years	0.0005	0.0142
1-6-1-A	3 13 years	0.0006	0.0084
2-49-0-E	2 23 years	0.0002	0.0037

Table C.1.3

Run 24-154

Readiness Condition X-RAY
Configuration Passive and Manual
Case Worst
Assumed Location In-Port
Run Time 60 minutes

Target Compartment	Magnitude/Frequency -of Acceptable Loss-		Relative Frequency of Loss FFS	Relative Loss Factor (RLF)
1-66-0-L	2	24 years	0.0708	1.6995
01-68-0-Q	2	22 years	0.0653	1.4359
01-68-1-L	2	22 years	0.0556	1.2223
01-78-3-E	2	24 years	0.0473	1.1347
03-76-0-Q	2	21 years	0.0471	0.9901
1-66-1-Q	2	26 years	0.0339	0.8808
1-71-2-Q	2	22 years	0.0364	0.8010
4-66-0-E	2	26 years	0.0298	0.7740
2-89-1-C	2	24 years	0.0281	0.6743
02-66-0-C	2	26 years	0.0238	0.6180
1-76-0-Q	3	16 years	0.0375	0.6000
4-82-0-E	2	22 years	0.0250	0.5506
2-57-4-E	2	22 years	0.0229	0.5048
2-59-1-Q	2	20 years	0.0229	0.4578
4-92-0-E	2	24 years	0.0189	0.4536
2-57-1-Q	2	20 years	0.0222	0.4430
1-85-2-Q	2	24 years	0.0152	0.3646
1-60-6B-A	3	13 years	0.0259	0.3369
03-56-0B-C	2	26 years	0.0113	0.2949
1-60-6A-A	3	13 years	0.0222	0.2888
1-74-2-Q	2	24 years	0.0120	0.2875
02-73-0-Q	2	22 years	0.0130	0.2864
1-60-4-A	2	23 years	0.0122	0.2809
1-60-2-A	2	23 years	0.0122	0.2809
1-102-0-E	2	26 years	0.0093	0.2407
4-12-0-E	2	24 years	0.0087	0.2085
1-66-3-Q	2	26 years	0.0074	0.1922
2-48-2-E	2	23 years	0.0077	0.1776
1-18-2-Q	2	24 years	0.0069	0.1666
2-21-2-Q	2	24 years	0.0050	0.1200
1-21-2-Q	2	23 years	0.0051	0.1181
1-18-1-Q	2	24 years	0.0039	0.0929
2-57-2-A	3	13 years	0.0068	0.0888
1-12-3-Q	2	20 years	0.0037	0.0735
03-66-01-C	2	24 years	0.0029	0.0702
03-56-0A-C	2	26 years	0.0016	0.0410
02-75-2-Q	3	17 years	0.0011	0.0192
1-6-2-A	1	30 years	0.0005	0.0136
2-49-0-E	2	23 years	0.0006	0.0129
02-75-1-Q	3	17 years	0.0007	0.0121
01-57-0-Q	2	26 years	0.0004	0.0112
1-6-1-A	3	13 years	0.0004	0.0056

Table C.1.4

Run 24-155

Readiness Condition X-RAY
 Configuration Passive
 Case Worst
 Assumed Location In-Port
 Run Time 60 minutes

Target Compartment	Magnitude/Frequency -of Acceptable Loss-		Relative Frequency of Loss FFS	Relative Loss Factor (RLF)
1-66-0-L	2	24 years	0.1376	3.3021
01-68-0-Q	2	22 years	0.1430	3.1462
01-68-1-L	2	22 years	0.1375	3.0260
02-66-0-C	2	26 years	0.0787	2.0454
01-78-3-E	2	24 years	0.0841	2.0182
1-66-1-Q	2	26 years	0.0670	1.7424
03-76-0-Q	2	21 years	0.0667	1.4009
1-71-2-Q	2	22 years	0.0610	1.3423
02-73-0-Q	2	22 years	0.0550	1.2101
03-56-0B-C	2	26 years	0.0462	1.2014
2-89-1-C	2	24 years	0.0394	0.9447
4-66-0-E	2	26 years	0.0357	0.9275
1-76-0-Q	3	16 years	0.0463	0.7401
2-59-1-Q	2	20 years	0.0365	0.7291
2-57-1-Q	2	20 years	0.0345	0.6910
4-82-0-E	2	22 years	0.0311	0.6841
2-57-4-E	2	22 years	0.0310	0.6812
1-60-4-A	2	23 years	0.0295	0.6789
1-60-2-A	2	23 years	0.0295	0.6789
1-60-6B-A	3	13 years	0.0499	0.6487
1-74-2-Q	2	24 years	0.0237	0.5700
4-92-0-E	2	24 years	0.0234	0.5622
1-85-2-Q	2	24 years	0.0206	0.4933
1-60-6A-A	3	13 years	0.0372	0.4831
1-66-3-Q	2	26 years	0.0157	0.4093
2-48-2-E	2	23 years	0.0132	0.3028
1-102-0-E	2	26 years	0.0101	0.2617
4-12-0-E	2	24 years	0.0099	0.2377
03-66-01-C	2	24 years	0.0082	0.1975
1-18-2-Q	2	24 years	0.0081	0.1949
1-21-2-Q	2	23 years	0.0071	0.1641
2-21-2-Q	2	24 years	0.0062	0.1478
03-56-0A-C	2	26 years	0.0054	0.1411
2-57-2-A	3	13 years	0.0104	0.1346
1-18-1-Q	2	24 years	0.0052	0.1245
1-12-3-Q	2	20 years	0.0061	0.1218
1-97-2-Q	2	22 years	0.0053	0.1170
02-75-2-Q	3	17 years	0.0020	0.0346
1-6-2-A	1	30 years	0.0007	0.0225
2-49-0-E	2	23 years	0.0007	0.0161
02-75-1-Q	3	17 years	0.0009	0.0145
01-57-0-Q	2	26 years	0.0005	0.0142
1-6-1-A	3	13 years	0.0006	0.0084

Table C.1.5

Run 24-156

Readiness Condition YOKE
Configuration Passive, Automatic, and Manual
Case Worst
Assumed Location In Port
Run Time 60 minutes

Target Compartment	Magnitude/Frequency -of Acceptable Loss-	Relative Frequency of Loss FFS	Relative Loss Factor (RLF)
1-66-0-L	2 24 years	0.0165	0.3967
01-68-0-Q	2 22 years	0.0170	0.3731
03-76-0-Q	2 21 years	0.0147	0.3088
01-68-1-L	2 22 years	0.0127	0.2791
1-66-1-Q	2 26 years	0.0080	0.2091
01-78-3-E	2 24 years	0.0078	0.1879
1-71-2-Q	2 22 years	0.0081	0.1784
1-76-0-Q	3 16 years	0.0110	0.1753
4-66-0-E	2 26 years	0.0065	0.1689
02-66-0-C	2 26 years	0.0064	0.1675
2-89-1-C	2 24 years	0.0058	0.1395
2-57-4-E	2 22 years	0.0060	0.1329
2-59-1-Q	2 20 years	0.0048	0.0953
02-73-0-Q	2 22 years	0.0042	0.0924
4-92-0-E	2 24 years	0.0038	0.0919
2-57-1-Q	2 20 years	0.0043	0.0858
03-56-0B-C	2 26 years	0.0033	0.0853
1-18-2-Q	2 24 years	0.0035	0.0849
4-82-0-E	2 22 years	0.0038	0.0839
1-74-2-Q	2 24 years	0.0032	0.0775
1-60-6B-A	3 13 years	0.0054	0.0699
4-12-0-E	2 24 years	0.0029	0.0686
1-85-2-Q	2 24 years	0.0028	0.0682
1-21-2-Q	2 23 years	0.0028	0.0652
1-60-6A-A	3 13 years	0.0049	0.0635
2-21-2-Q	2 24 years	0.0025	0.0605
1-60-4-A	2 23 years	0.0025	0.0571
1-60-2-A	2 23 years	0.0025	0.0571
03-66-01-C	2 24 years	0.0023	0.0548
1-66-3-Q	2 26 years	0.0019	0.0496
03-56-0A-C	2 26 years	0.0015	0.0402
2-57-2-A	3 13 years	0.0026	0.0334
1-18-1-Q	2 24 years	0.0014	0.0328
2-48-2-E	2 23 years	0.0013	0.0291
1-12-3-Q	2 20 years	0.0014	0.0277
02-75-2-Q	3 17 years	0.0010	0.0177
1-6-2-A	1 30 years	0.0004	0.0128
02-75-1-Q	3 17 years	0.0007	0.0121
01-57-0-Q	2 26 years	0.0004	0.0112
1-6-1-A	3 13 years	0.0004	0.0056

Table C.1.6

Readiness Condition YOKE
 Configuration Passive and Automatic
 Case Worst
 Assumed Location In Port
 Run Time 60 minutes

Target Compartment	Magnitude/Frequency -of Acceptable Loss-	Relative Frequency of Loss FFS	Relative Loss Factor (RLF)
01-68-0-Q	2 22 years	0.0367	0.8063
1-66-0-L	2 24 years	0.0310	0.7432
01-68-1-L	2 22 years	0.0325	0.7148
02-66-0-C	2 26 years	0.0197	0.5115
03-76-0-Q	2 21 years	0.0209	0.4386
1-66-1-Q	2 26 years	0.0157	0.4072
02-73-0-Q	2 22 years	0.0172	0.3781
1-71-2-Q	2 22 years	0.0141	0.3102
03-56-0B-C	2 26 years	0.0119	0.3101
01-78-3-E	2 24 years	0.0111	0.2670
1-76-0-Q	3 16 years	0.0136	0.2176
2-89-1-C	2 24 years	0.0087	0.2088
4-66-0-E	2 26 years	0.0080	0.2069
2-57-4-E	2 22 years	0.0079	0.1732
1-60-4-A	2 23 years	0.0066	0.1510
1-60-2-A	2 23 years	0.0066	0.1510
2-59-1-Q	2 20 years	0.0074	0.1478
1-60-6B-A	3 13 years	0.0111	0.1445
1-74-2-Q	2 24 years	0.0059	0.1421
2-57-1-Q	2 20 years	0.0071	0.1414
1-60-6A-A	3 13 years	0.0087	0.1126
03-66-01-C	2 24 years	0.0047	0.1119
4-82-0-E	2 22 years	0.0048	0.1061
4-92-0-E	2 24 years	0.0043	0.1038
1-18-2-Q	2 24 years	0.0041	0.0991
1-66-3-Q	2 26 years	0.0037	0.0972
1-85-2-Q	2 24 years	0.0040	0.0956
03-56-0A-C	2 26 years	0.0034	0.0891
1-21-2-Q	2 23 years	0.0038	0.0870
4-12-0-E	2 24 years	0.0033	0.0784
2-21-2-Q	2 24 years	0.0030	0.0718
2-57-2-A	3 13 years	0.0038	0.0500
2-48-2-E	2 23 years	0.0022	0.0497
1-12-3-Q	2 20 years	0.0023	0.0467
1-18-1-Q	2 24 years	0.0019	0.0451
02-75-2-Q	3 17 years	0.0017	0.0297
1-6-2-A	1 30 years	0.0007	0.0211
02-75-1-Q	3 17 years	0.0009	0.0145
01-57-0-Q	2 26 years	0.0005	0.0142
1-6-1-A	3 13 years	0.0006	0.0084

Table C.1.7

Readiness Condition YOKE
 Configuration Passive and Manual
 Case Worst
 Assumed Location In Port
 Run Time 60 minutes

Target Compartment	Magnitude/Frequency -of Acceptable Loss-		Relative Frequency of Loss FFS	Relative Loss Factor (RLF)
1-66-0-L	2	24 years	0.0590	1.4160
01-68-0-Q	2	22 years	0.0544	1.1967
01-68-1-L	2	22 years	0.0453	0.9966
01-78-3-E	2	24 years	0.0405	0.9719
03-76-0-Q	2	21 years	0.0379	0.7964
1-66-1-Q	2	26 years	0.0289	0.7526
1-71-2-Q	2	22 years	0.0297	0.6540
4-66-0-E	2	26 years	0.0244	0.6347
2-89-1-C	2	24 years	0.0241	0.5781
1-76-0-Q	3	16 years	0.0315	0.5040
02-66-0-C	2	26 years	0.0186	0.4828
4-82-0-E	2	22 years	0.0204	0.4497
2-57-4-E	2	22 years	0.0183	0.4015
2-59-1-Q	2	20 years	0.0187	0.3744
2-57-1-Q	2	20 years	0.0179	0.3573
4-92-0-E	2	24 years	0.0136	0.3262
1-85-2-Q	2	24 years	0.0125	0.3001
1-74-2-Q	2	24 years	0.0120	0.2875
1-60-6B-A	3	13 years	0.0215	0.2792
1-60-4-A	2	23 years	0.0104	0.2393
1-60-2-A	2	23 years	0.0104	0.2393
1-60-6A-A	3	13 years	0.0184	0.2393
02-73-0-Q	2	22 years	0.0106	0.2322
03-56-0B-C	2	26 years	0.0089	0.2321
4-12-0-E	2	24 years	0.0087	0.2085
1-66-3-Q	2	26 years	0.0074	0.1914
1-18-2-Q	2	24 years	0.0069	0.1666
2-48-2-E	2	23 years	0.0054	0.1240
2-21-2-Q	2	24 years	0.0050	0.1199
1-21-2-Q	2	23 years	0.0051	0.1181
1-18-1-Q	2	24 years	0.0039	0.0928
2-57-2-A	3	13 years	0.0061	0.0787
1-12-3-Q	2	20 years	0.0037	0.0735
03-66-01-C	2	24 years	0.0028	0.0661
03-56-0A-C	2	26 years	0.0015	0.0402
02-75-2-Q	3	17 years	0.0010	0.0177
1-6-2-A	1	30 years	0.0005	0.0136
02-75-1-Q	3	17 years	0.0007	0.0121
01-57-0-Q	2	26 years	0.0004	0.0112
1-6-1-A	3	13 years	0.0004	0.0056

Table C.1.8

Run 24-159

Readiness Condition YOKE
Configuration Passive
Case Worst
Assumed Location In Port
Run Time 60 minutes

Target Compartment	Magnitude/Frequency -of Acceptable Loss-	Relative Frequency of Loss FFS	Relative Loss Factor (RLF)
1-66-0-L	2 24 years	0.1095	2.6273
01-68-0-Q	2 22 years	0.1156	2.5426
01-68-1-L	2 22 years	0.1147	2.5243
01-78-3-E	2 24 years	0.0707	1.6957
02-66-0-C	2 26 years	0.0618	1.6068
1-66-1-Q	2 26 years	0.0550	1.4289
1-71-2-Q	2 22 years	0.0494	1.0870
03-76-0-Q	2 21 years	0.0517	1.0856
02-73-0-Q	2 22 years	0.0449	0.9870
03-56-0B-C	2 26 years	0.0337	0.8755
2-89-1-C	2 24 years	0.0335	0.8039
4-66-0-E	2 26 years	0.0289	0.7524
1-76-0-Q	3 16 years	0.0372	0.5953
2-59-1-Q	2 20 years	0.0294	0.5885
1-74-2-Q	2 24 years	0.0237	0.5700
4-82-0-E	2 22 years	0.0256	0.5636
2-57-1-Q	2 20 years	0.0273	0.5457
1-60-4-A	2 23 years	0.0234	0.5388
1-60-2-A	2 23 years	0.0234	0.5388
2-57-4-E	2 22 years	0.0243	0.5345
1-60-6B-A	3 13 years	0.0406	0.5272
1-85-2-Q	2 24 years	0.0170	0.4078
4-92-0-E	2 24 years	0.0170	0.4074
1-66-3-Q	2 26 years	0.0155	0.4028
1-60-6A-A	3 13 years	0.0302	0.3932
4-12-0-E	2 24 years	0.0099	0.2376
2-48-2-E	2 23 years	0.0088	0.2018
1-18-2-Q	2 24 years	0.0081	0.1949
03-66-01-C	2 24 years	0.0069	0.1653
1-21-2-Q	2 23 years	0.0071	0.1641
2-21-2-Q	2 24 years	0.0062	0.1477
03-56-0A-C	2 26 years	0.0048	0.1243
1-18-1-Q	2 24 years	0.0052	0.1238
1-12-3-Q	2 20 years	0.0061	0.1218
2-57-2-A	3 13 years	0.0092	0.1201
02-75-2-Q	3 17 years	0.0017	0.0297
1-6-2-A	1 30 years	0.0007	0.0225
02-75-1-Q	3 17 years	0.0009	0.0145
01-57-0-Q	2 26 years	0.0005	0.0142
1-6-1-A	3 13 years	0.0006	0.0084

Table C.1.9

Readiness Condition YOKE
 Configuration Passive, Automatic, and Manual
 Case Worst
 Assumed Location At Sea
 Run Time 60 minutes

Target Compartment	Magnitude/Frequency -of Acceptable Loss-	Relative Frequency of Loss FFS	Relative Loss Factor (RLF)
1-66-0-L	2 24 years	0.0135	0.3249
01-68-0-Q	2 22 years	0.0129	0.2836
03-76-0-Q	2 21 years	0.0120	0.2518
01-68-1-L	2 22 years	0.0094	0.2067
01-78-3-E	2 24 years	0.0072	0.1721
4-66-0-E	2 26 years	0.0062	0.1621
1-76-0-Q	3 16 years	0.0100	0.1604
1-66-1-Q	2 26 years	0.0061	0.1577
1-71-2-Q	2 22 years	0.0069	0.1526
2-89-1-C	2 24 years	0.0053	0.1270
02-66-0-C	2 26 years	0.0046	0.1209
2-57-4-E	2 22 years	0.0055	0.1201
4-92-0-E	2 24 years	0.0038	0.0902
1-18-2-Q	2 24 years	0.0033	0.0788
2-57-1-Q	2 20 years	0.0039	0.0772
2-59-1-Q	2 20 years	0.0038	0.0764
4-82-0-E	2 22 years	0.0035	0.0760
02-73-0-Q	2 22 years	0.0034	0.0749
03-56-0B-C	2 26 years	0.0026	0.0686
4-12-0-E	2 24 years	0.0027	0.0638
1-74-2-Q	2 24 years	0.0025	0.0599
1-85-2-Q	2 24 years	0.0025	0.0597
1-60-6B-A	3 13 years	0.0045	0.0588
1-21-2-Q	2 23 years	0.0025	0.0576
2-21-2-Q	2 24 years	0.0024	0.0565
1-60-6A-A	3 13 years	0.0041	0.0536
03-66-01-C	2 24 years	0.0020	0.0471
1-60-4-A	2 23 years	0.0019	0.0428
1-60-2-A	2 23 years	0.0019	0.0428
1-66-3-Q	2 26 years	0.0016	0.0418
03-56-0A-C	2 26 years	0.0013	0.0334
2-57-2-A	3 13 years	0.0023	0.0295
1-18-1-Q	2 24 years	0.0012	0.0282
2-48-2-E	2 23 years	0.0011	0.0254
1-12-3-Q	2 20 years	0.0011	0.0227
02-75-2-Q	3 17 years	0.0009	0.0158
1-6-2-A	1 30 years	0.0004	0.0119
02-75-1-Q	3 17 years	0.0006	0.0108
01-57-0-Q	2 26 years	0.0004	0.0105
1-6-1-A	3 13 years	0.0004	0.0051

Table C.1.10

Run 23-149

Readiness Condition YOKE
Configuration Passive and Automatic
Case Worst
Assumed Location At Sea
Run Time 60 minutes

Target Compartment	Magnitude/Frequency -of Acceptable Loss-	Relative Frequency of Loss FFS	Relative Loss Factor (RLF)
01-68-0-Q	2 22 years	0.0366	0.8053
1-66-0-L	2 24 years	0.0308	0.7399
01-68-1-L	2 22 years	0.0324	0.7133
02-66-0-C	2 26 years	0.0196	0.5105
1-66-1-Q	2 26 years	0.0157	0.4078
03-76-0-Q	2 21 years	0.0194	0.4068
02-73-0-Q	2 22 years	0.0170	0.3732
1-71-2-Q	2 22 years	0.0144	0.3170
03-56-0B-C	2 26 years	0.0119	0.3102
01-78-3-E	2 24 years	0.0111	0.2655
4-66-0-E	2 26 years	0.0082	0.2120
1-76-0-Q	3 16 years	0.0132	0.2118
2-89-1-C	2 24 years	0.0088	0.2106
2-57-4-E	2 22 years	0.0080	0.1767
1-60-4-A	2 23 years	0.0067	0.1530
1-60-2-A	2 23 years	0.0067	0.1530
2-59-1-Q	2 20 years	0.0076	0.1518
1-60-6B-A	3 13 years	0.0114	0.1479
2-57-1-Q	2 20 years	0.0073	0.1453
1-74-2-Q	2 24 years	0.0060	0.1430
1-60-6A-A	3 13 years	0.0089	0.1152
03-66-01-C	2 24 years	0.0047	0.1125
4-82-0-E	2 22 years	0.0048	0.1065
4-92-0-E	2 24 years	0.0042	0.1019
1-66-3-Q	2 26 years	0.0038	0.0980
1-18-2-Q	2 24 years	0.0041	0.0979
1-85-2-Q	2 24 years	0.0040	0.0956
03-56-0A-C	2 26 years	0.0034	0.0892
1-21-2-Q	2 23 years	0.0037	0.0859
4-12-0-E	2 24 years	0.0031	0.0753
2-21-2-Q	2 24 years	0.0030	0.0709
2-57-2-A	3 13 years	0.0039	0.0502
2-48-2-E	2 23 years	0.0022	0.0501
1-12-3-Q	2 20 years	0.0023	0.0455
1-18-1-Q	2 24 years	0.0018	0.0439
02-75-2-Q	3 17 years	0.0018	0.0310
1-6-2-A	1 30 years	0.0007	0.0211
02-75-1-Q	3 17 years	0.0009	0.0145
01-57-0-Q	2 26 years	0.0005	0.0142
1-6-1-A	3 13 years	0.0006	0.0084

Table C.1.11

Run 23-150

Readiness Condition YOKE
Configuration Passive and Manual
Case Worst
Assumed Location At Sea
Run Time 60 minutes

Target Compartment	Magnitude/Frequency -of Acceptable Loss-	Relative Frequency of Loss FFS	Relative Loss Factor (RLF)
1-66-0-L	2 24 years	0.0485	1.1630
01-68-0-Q	2 22 years	0.0419	0.9228
01-78-3-E	2 24 years	0.0341	0.8188
01-68-1-L	2 22 years	0.0336	0.7397
03-76-0-Q	2 21 years	0.0312	0.6542
1-66-1-Q	2 26 years	0.0237	0.6165
4-66-0-E	2 26 years	0.0233	0.6068
1-71-2-Q	2 22 years	0.0256	0.5636
2-89-1-C	2 24 years	0.0217	0.5205
1-76-0-Q	3 16 years	0.0289	0.4631
4-82-0-E	2 22 years	0.0185	0.4074
2-57-4-E	2 22 years	0.0170	0.3748
02-66-0-C	2 26 years	0.0140	0.3636
2-59-1-Q	2 20 years	0.0165	0.3304
2-57-1-Q	2 20 years	0.0161	0.3210
4-92-0-E	2 24 years	0.0116	0.2773
1-85-2-Q	2 24 years	0.0107	0.2563
1-60-6B-A	3 13 years	0.0179	0.2323
1-74-2-Q	2 24 years	0.0094	0.2256
1-60-6A-A	3 13 years	0.0159	0.2072
4-12-0-E	2 24 years	0.0081	0.1935
02-73-0-Q	2 22 years	0.0086	0.1883
1-60-4-A	2 23 years	0.0074	0.1710
1-60-2-A	2 23 years	0.0074	0.1710
03-56-0B-C	2 26 years	0.0065	0.1697
1-66-3-Q	2 26 years	0.0060	0.1569
1-18-2-Q	2 24 years	0.0064	0.1535
2-21-2-Q	2 24 years	0.0046	0.1106
2-48-2-E	2 23 years	0.0047	0.1075
1-21-2-Q	2 23 years	0.0045	0.1040
1-18-1-Q	2 24 years	0.0035	0.0833
2-57-2-A	3 13 years	0.0053	0.0684
1-12-3-Q	2 20 years	0.0031	0.0610
03-66-01-C	2 24 years	0.0023	0.0546
03-56-0A-C	2 26 years	0.0013	0.0334
02-75-2-Q	3 17 years	0.0009	0.0158
1-6-2-A	1 30 years	0.0004	0.0125
02-75-1-Q	3 17 years	0.0006	0.0108
01-57-0-Q	2 26 years	0.0004	0.0105
1-6-1-A	3 13 years	0.0004	0.0051

Table C.1.12

Run 23-151

Readiness Condition YOKE
Configuration Passive
Case Worst
Assumed Location At Sea
Run Time 60 minutes

Target Compartment	Magnitude/Frequency -of Acceptable Loss-	Relative Frequency of Loss FFS	Relative Loss Factor (RLF)
1-66-0-L	2 24 years	0.1104	2.6496
01-68-0-Q	2 22 years	0.1151	2.5322
01-68-1-L	2 22 years	0.1147	2.5244
01-78-3-E	2 24 years	0.0704	1.6891
02-66-0-C	2 26 years	0.0612	1.5913
1-66-1-Q	2 26 years	0.0553	1.4365
1-71-2-Q	2 22 years	0.0508	1.1186
03-76-0-Q	2 21 years	0.0480	1.0073
02-73-0-Q	2 22 years	0.0442	0.9729
03-56-0B-C	2 26 years	0.0331	0.8609
2-89-1-C	2 24 years	0.0336	0.8057
4-66-0-E	2 26 years	0.0296	0.7699
2-59-1-Q	2 20 years	0.0303	0.6066
1-76-0-Q	3 16 years	0.0363	0.5800
1-74-2-Q	2 24 years	0.0238	0.5703
2-57-1-Q	2 20 years	0.0281	0.5622
4-82-0-E	2 22 years	0.0255	0.5603
1-60-4-A	2 23 years	0.0240	0.5509
1-60-2-A	2 23 years	0.0240	0.5509
2-57-4-E	2 22 years	0.0250	0.5496
1-60-6B-A	3 13 years	0.0417	0.5420
1-85-2-Q	2 24 years	0.0169	0.4056
1-60-6A-A	3 13 years	0.0311	0.4039
1-66-3-Q	2 26 years	0.0155	0.4025
4-92-0-E	2 24 years	0.0146	0.3515
4-12-0-E	2 24 years	0.0095	0.2283
2-48-2-E	2 23 years	0.0089	0.2041
1-18-2-Q	2 24 years	0.0080	0.1919
03-66-01-C	2 24 years	0.0068	0.1642
1-21-2-Q	2 23 years	0.0069	0.1598
2-21-2-Q	2 24 years	0.0060	0.1446
03-56-0A-C	2 26 years	0.0047	0.1232
2-57-2-A	3 13 years	0.0093	0.1210
1-18-1-Q	2 24 years	0.0050	0.1196
1-12-3-Q	2 20 years	0.0059	0.1181
02-75-2-Q	3 17 years	0.0018	0.0310
1-6-2-A	1 30 years	0.0007	0.0225
02-75-1-Q	3 17 years	0.0009	0.0145
01-57-0-Q	2 26 years	0.0005	0.0142
1-6-1-A	3 13 years	0.0006	0.0084

ROOM OF ORIGIN BARRIER OPTION - SUMMARY LEVEL REPORT

LISTING OF ROOM OF ORIGIN BARRIER FAILURES
 ORDERED BY ROOM OF ORIGIN AND SECONDARILY BY
 PROBABILITY OF LOSS|EB AT TIME OF BARRIER FAILURE

READINESS CONDITION . XRAY
 CONFIGURATION Passive, Automatic, and Manual
 CASE Worst
 ASSUMED LOCATION in Port
 RUN TIME 60 minutes
 COMMENTS
 Ship Visit Baseline
 In Port

-----Room of Origin-----			-----Barrier to Adjacent Room-----				
Plan ID	FRI P(Loss) Time EB	RFL FFS (x 1000)	Adj. Room Plan ID	Fail Time	P(Loss) EB	RFL FFS (x 1000)	Opening/ Zero-Str
4-12-0-E	3 0.09	2.50	2-21-2-Q	11	0.01	0.30	
			2-21-1-A	11	0.01	0.30	
			2-21-0-L	11	0.01	0.30	
			not analyzed	11	0.01	0.30	
			not analyzed	11	0.01	0.30	
			not analyzed	11	0.01	0.30	
			not analyzed	11	0.01	0.30	
			not analyzed	11	0.01	0.30	
			not analyzed	11	0.01	0.30	
			not analyzed	11	0.01	0.30	
			not analyzed	11	0.01	0.30	
			not analyzed	11	0.01	0.30	
			not analyzed	11	0.01	0.30	
			4-17-2-V	11	0.01	0.30	
			not analyzed	11	0.01	0.30	
			1-19-2-T	16	0.01	0.28	
			1-18-4-A	16	0.01	0.28	
			1-18-2-Q	16	0.01	0.28	
			1-18-1-Q	16	0.01	0.28	
			1-15-1-L	16	0.01	0.28	
			1-12-3-Q	16	0.01	0.28	
			not analyzed	16	0.01	0.28	
			1-12-1A-L	16	0.01	0.28	
			not analyzed	16	0.01	0.28	
			not analyzed	16	0.01	0.28	
			ext. blkhd.	16	0.01	0.28	
			not analyzed	47	0.00	0.27	
			4-6-0C-W	47	0.00	0.27	
			4-6-0A-W	47	0.00	0.27	
			not analyzed	47	0.00	0.27	
			4-17-2-V	47	0.00	0.27	
			not analyzed	47	0.00	0.27	
			4-6-0C-W	47	0.00	0.27	
			4-6-0B-W	47	0.00	0.27	
			4-6-0A-W	47	0.00	0.27	
			ext. blkhd.	39	0.00	0.26	
			ext. blkhd.	39	0.00	0.26	
			ext. blkhd.	39	0.00	0.26	
			ext. blkhd.	39	0.00	0.26	
			ext. blkhd.	39	0.00	0.26	
			ext. blkhd.	39	0.00	0.26	

-----Room of Origin-----				-----Barrier to Adjacent Room-----				
Plan ID	FRI Time	P(Loss) EB	RFL FFS (x 1000)	Adj. Room Plan ID	Fail Time	P(Loss) EB	RFL FFS (x 1000)	Opening/ Zero-Str
4-66-0-E	3	0.13	3.42	2-89-1-C	3	0.13	3.42	Opening
				1-76-0-Q	3	0.13	3.42	Zero-Str
				1-66-2-L	3	0.13	3.42	Opening
				2-89-1-C	3	0.13	3.42	Opening
				2-89-1-C	5	0.03	0.89	
				ext. blkhd.	6	0.02	0.64	
				ext. blkhd.	6	0.02	0.64	
				ext. blkhd.	6	0.02	0.64	
				ext. blkhd.	6	0.02	0.64	
				ext. blkhd.	6	0.02	0.64	
				ext. blkhd.	6	0.02	0.64	
				ext. blkhd.	6	0.02	0.64	
				4-80-0-W	6	0.02	0.64	
				4-80-0-W	6	0.02	0.64	
				4-80-0-W	6	0.02	0.64	
				4-80-0-W	6	0.02	0.64	
				4-80-0-W	6	0.02	0.64	
				4-80-0-W	6	0.02	0.64	
				4-80-0-W	6	0.02	0.64	
				not analyzed	6	0.02	0.64	
				not analyzed	6	0.02	0.64	
				not analyzed	6	0.02	0.64	
				not analyzed	6	0.02	0.64	
				ext. blkhd.	6	0.02	0.64	
				ext. blkhd.	6	0.02	0.64	
				ext. blkhd.	6	0.02	0.64	
				ext. blkhd.	6	0.02	0.64	
				4-82-0-E	6	0.01	0.39	
				1-80-1-E	6	0.01	0.39	
				1-77-3-L	6	0.01	0.39	
				1-77-2-L	6	0.01	0.39	
				1-77-1-A	6	0.01	0.39	
				1-74-2-Q	6	0.01	0.39	
				1-71-2-Q	6	0.01	0.39	
				1-66-1-Q	6	0.01	0.39	
				1-66-0-L	6	0.01	0.39	
				1-60-6A-A	6	0.01	0.39	
				1-66-3-Q	6	0.01	0.39	
				2-59-1-Q	6	0.01	0.39	
				2-57-4-E	6	0.01	0.39	
				2-57-1-Q	6	0.01	0.39	
				2-57-0-L	6	0.01	0.39	
				4-82-0-E	6	0.01	0.39	
				not analyzed	6	0.01	0.39	
				not analyzed	6	0.01	0.39	
				4-57-0C-W	6	0.01	0.39	
				4-57-0A-W	6	0.01	0.39	
				3-57-0-A	6	0.01	0.39	
				4-82-0-E	6	0.01	0.39	
				4-82-0-E	6	0.01	0.39	
				not analyzed	6	0.01	0.39	
				not analyzed	6	0.01	0.39	
				4-57-0C-W	6	0.01	0.39	
				4-57-0A-W	6	0.01	0.39	
				4-80-0-W	14	0.01	0.35	

-----Room of Origin-----				-----Barrier to Adjacent Room-----			
Plan ID	FRI P(Loss) Time EB	RFL FFS (x 1000)	Adj. Room Plan ID	Fail P(Loss) Time EB	RFL FFS (x 1000)	Opening/ Zero-Str	
			not analyzed	14	0.01	0.35	
4-82-0-E	3	0.14	1-84-2-L	3	0.14	0.39	
		0.39	1-85-2-Q	7	0.14	0.39	
			1-85-2-Q	5	0.02	0.07	
			1-82-0-L	5	0.02	0.07	
			1-76-0-Q	5	0.02	0.07	
			2-89-1-C	11	0.02	0.06	
			1-82-0-L	14	0.02	0.05	
			ext. blkhd.	13	0.02	0.05	
			ext. blkhd.	13	0.02	0.05	
			ext. blkhd.	13	0.02	0.05	
			ext. blkhd.	13	0.02	0.05	
			ext. blkhd.	13	0.02	0.05	
			ext. blkhd.	13	0.02	0.05	
			ext. blkhd.	13	0.02	0.05	
			4-80-0-W	13	0.02	0.05	
			ext. blkhd.	13	0.02	0.05	
			ext. blkhd.	13	0.02	0.05	
			4-66-0-E	9	0.02	0.04	
			4-66-0-E	9	0.02	0.04	
			4-66-0-E	9	0.02	0.04	
			4-66-0-E	9	0.02	0.04	
			1-76-0-Q	6	0.02	0.04	
			1-85-1-L	15	0.02	0.04	
			1-82-1-L	15	0.02	0.04	
			4-92-0-E	15	0.02	0.04	
			1-85-4-L	15	0.02	0.04	
			1-85-3-L	15	0.02	0.04	
			1-85-1-L	15	0.02	0.04	
			1-82-4-L	15	0.02	0.04	
			1-82-3-L	15	0.02	0.04	
			1-82-2-Q	15	0.02	0.04	
			1-82-1-L	15	0.02	0.04	
			4-92-0-E	15	0.02	0.04	
			4-92-0-E	15	0.02	0.04	
4-92-0-E	2	0.13	1-92-0-L	2	0.13	3.64	
		3.64	ext. blkhd.	14	0.02	0.44	
			ext. blkhd.	14	0.02	0.44	
			ext. blkhd.	14	0.02	0.44	
			ext. blkhd.	14	0.02	0.44	
			ext. blkhd.	14	0.02	0.44	
			ext. blkhd.	14	0.02	0.44	
			ext. blkhd.	14	0.02	0.44	
			ext. blkhd.	14	0.02	0.44	
			ext. blkhd.	14	0.02	0.44	
			ext. blkhd.	14	0.02	0.44	
			ext. blkhd.	14	0.02	0.44	
			1-92-2-L	15	0.01	0.37	
			1-96-1-L	15	0.01	0.37	
			1-96-0-L	15	0.01	0.37	
			1-92-1-L	15	0.01	0.37	

-----Room of Origin-----				-----Barrier to Adjacent Room-----				
Plan ID	FRI Time	P(Loss) EB	RFL FFS (x 1000)	Adj. Room Plan ID	Fail Time	P(Loss) EB	RFL FFS (x 1000)	Opening/Zero-Str
				4-82-0-E	15	0.01	0.37	
				4-82-0-E	15	0.01	0.37	
				ext. blkhd.	15	0.01	0.37	
				4-82-0-E	15	0.01	0.37	
				ext. blkhd.	15	0.01	0.37	
3-57-0-A	5	0.48	0.43	4-57-0C-W	11	0.06	0.06	
				4-57-0A-W	11	0.06	0.06	
				4-66-0-E	37	0.05	0.04	
				not analyzed	37	0.05	0.04	
				not analyzed	37	0.05	0.04	
				2-59-1-Q	37	0.05	0.04	
				2-57-0-L	37	0.05	0.04	
				not analyzed	37	0.05	0.04	
2-21-1-A	6	0.48	0.43	2-21-0-L	6	0.48	0.43	Zero-Str
				2-30-0-AA	12	0.06	0.06	
				4-12-0-E	12	0.06	0.06	
				1-21-3-L	21	0.06	0.06	
				ext. blkhd.	33	0.05	0.05	
				ext. ovrhd.	38	0.05	0.04	
2-21-2-Q	2	0.45	1.30	2-30-0-AA	24	0.05	0.14	
				2-21-0-L	24	0.05	0.14	
				4-12-0-E	24	0.05	0.14	
2-30-0-AA	4	0.04	0.00	2-21-0-L	4	0.04	0.00	Opening
				2-25-2-W	15	0.00	0.00	
				2-25-1-WW	15	0.00	0.00	
				2-21-2-Q	15	0.00	0.00	
				ext. blkhd.	54	0.00	0.00	
				ext. blkhd.	54	0.00	0.00	
				ext. blkhd.	54	0.00	0.00	
				2-21-1-A	10	0.00	0.00	
2-48-2-E	2	0.22	0.63	ext. ovrhd.	2	0.22	0.63	Opening
				2-57-4-E	8	0.02	0.07	
				2-57-2-A	8	0.02	0.07	
				ext. blkhd.	31	0.02	0.07	
				2-49-0-E	37	0.02	0.07	
				2-48-0-V	37	0.02	0.07	
				not analyzed	37	0.02	0.07	
				2-39-2-V	37	0.02	0.07	
2-50-1-A	4	0.48	0.43	2-48-1-L	4	0.48	0.43	Zero-Str
				2-48-1-L	4	0.48	0.43	Opening
				2-57-1-Q	10	0.06	0.06	
				2-53-1-L	10	0.06	0.06	
				ext. blkhd.	31	0.05	0.05	
				ext. ovrhd.	36	0.05	0.04	
2-57-2-A	4	0.48	0.43	2-57-4-E	4	0.48	0.43	
				2-57-4-E	4	0.48	0.43	
				1-60-4-A	4	0.48	0.43	
				1-60-2-A	4	0.48	0.43	
				1-57-4-Q	4	0.48	0.43	
				1-57-2-L	4	0.48	0.43	
				2-57-0-L	4	0.48	0.43	Opening
				2-48-2-E	4	0.48	0.43	
				4-57-0A-W	5	0.08	0.07	
2-57-4-E	2	0.45	1.30	2-57-2-A	40	0.05	0.14	
				2-57-2-A	40	0.05	0.14	

-----Room of Origin-----				-----Barrier to Adjacent Room-----				
Plan ID	FRI Time	P(Loss) EB	RFL FFS (x 1000)	Adj. Room Plan ID	Fail Time	P(Loss) EB	RFL FFS (x 1000)	Opening/ Zero-Str
				2-48-2-E	40	0.05	0.14	
1-89-1-C	6	0.41	0.49	1-77-3-L	21	0.05	0.06	
				1-66-3-Q	21	0.05	0.06	
				1-66-0-L	21	0.05	0.06	
				4-82-0-E	21	0.05	0.06	
				4-66-0-E	21	0.05	0.06	
				4-66-0-E	21	0.05	0.06	
				ext. blkhd.	18	0.04	0.05	
1-6-1-A	5	0.48	0.43	1-12-1B-L	5	0.48	0.43	Zero-Str
				1-12-1B-L	5	0.48	0.43	Zero-Str
				ext. ovrhd.	5	0.48	0.43	Opening
				1-0-0-A	5	0.36	0.32	
				ext. blkhd.	6	0.21	0.19	
				1-12-3-Q	6	0.16	0.14	
				1-6-2-A	6	0.16	0.14	
				not analyzed	8	0.06	0.06	
				4-6-0C-W	8	0.06	0.06	
				2-6-1-Q	8	0.06	0.06	
1-18-2-Q	1	0.47	1.36	1-12-1A-L	1	0.47	1.36	Zero-Str
				1-19-2-T	1	0.44	1.28	
				1-18-4-A	1	0.44	1.28	
				not analyzed	1	0.44	1.28	
				1-21-2-Q	1	0.06	0.19	
				ext. ovrhd.	1	0.06	0.19	
				4-12-0-E	3	0.06	0.18	
1-21-2-Q	2	0.45	0.81	1-18-4-A	2	0.45	0.81	Opening
				ext. blkhd.	2	0.45	0.81	Opening
				ext. blkhd.	6	0.07	0.12	
				3-23-0-Q	7	0.07	0.12	
				3-23-0-Q	7	0.07	0.12	
				1-21-1-L	7	0.07	0.12	
				1-19-2-T	7	0.07	0.12	
				1-18-2-Q	7	0.07	0.12	
				ext. ovrhd.	7	0.07	0.12	
1-21-3-L	13	0.07	0.00	1-18-1-Q	19	0.00	0.00	
				ext. blkhd.	42	0.00	0.00	
				1-21-1-L	48	0.00	0.00	
				ext. blkhd.	48	0.00	0.00	
				ext. ovrhd.	48	0.00	0.00	
1-57-4-Q	2	0.04	0.00	1-57-2-L	2	0.04	0.00	Opening
				1-60-6B-A	3	0.01	0.00	
				01-57-4-L	3	0.00	0.00	
				01-57-2-L	3	0.00	0.00	
				2-57-2-A	20	0.00	0.00	
				ext. blkhd.	6	0.00	0.00	
				1-60-4-A	7	0.00	0.00	
				1-60-2-A	7	0.00	0.00	
				ext. blkhd.	7	0.00	0.00	
				ext. ovrhd.	7	0.00	0.00	
1-60-6A-A	4	0.48	0.43	1-60-6B-A	4	0.48	0.43	Zero-Str
				1-71-2-Q	4	0.36	0.32	
				ext. blkhd.	5	0.21	0.19	
				1-66-2-L	5	0.16	0.14	
				01-70-2-Q	5	0.16	0.14	
				01-66-2-L	5	0.16	0.14	

-----Room of Origin-----				-----Barrier to Adjacent Room-----				
Plan ID	FRI P(Loss) Time EB	RFL FFS (x 1000)	Adj. Room Plan ID	Fail P(Loss) Time EB	RFL FFS (x 1000)	Opening/ Zero-Str		
			ext. ovrhd.	5	0.16	0.14		
			4-66-0-E	16	0.06	0.06		
1-60-6B-A	5	0.48	0.43	1-60-6A-A	5	0.48	0.43	Zero-Str
			1-57-2-L	5	0.48	0.43	Opening	
			1-57-4-Q	5	0.36	0.32		
			ext. blkhd.	6	0.21	0.19		
			1-66-2-L	6	0.16	0.14		
			01-83-2-L	6	0.16	0.14		
			1-60-4-A	6	0.16	0.14		
			1-60-4-A	6	0.16	0.14		
			1-60-2-A	6	0.16	0.14		
			ext. ovrhd.	6	0.16	0.14		
			2-57-4-E	17	0.06	0.06		
1-71-2-Q	5	0.56	0.22	1-77-2-L	19	0.06	0.02	
			1-74-2-Q	19	0.06	0.02		
			1-66-0-L	19	0.06	0.02		
			1-60-6A-A	19	0.06	0.02		
1-76-0-Q	2	0.81	1.05	4-66-0-E	2	0.81	1.05	Zero-Str
			ext. blkhd.	2	0.43	0.55		
			ext. blkhd.	2	0.43	0.55		
			1-80-1-Q	2	0.43	0.55		
			02-73-0-Q	2	0.43	0.55		
			02-73-0-Q	2	0.43	0.55		
			01-74-1-L	2	0.43	0.55		
			01-74-1-L	2	0.43	0.55		
			01-60-0A-L	2	0.43	0.55		
			4-82-0-E	2	0.43	0.55		
			1-66-0-L	2	0.43	0.55		
			03-76-0-Q	2	0.31	0.41		
			02-85-0-Q	3	0.09	0.12		
			02-73-0-Q	3	0.09	0.12		
			1-80-1-Q	3	0.09	0.12		
			01-79-0B-L	3	0.09	0.12		
			01-79-0A-L	3	0.09	0.12		
			01-78-3-E	3	0.09	0.12		
			01-78-1-F	3	0.09	0.12		
			01-68-0-Q	3	0.09	0.12		
			1-80-1-E	3	0.09	0.12		
			1-77-1-A	3	0.09	0.12		
			1-66-0-L	3	0.09	0.12		
			1-66-0-L	3	0.09	0.12		
1-77-3-L	21	0.48	0.38	01-78-3-E	44	0.05	0.04	
			01-68-1-L	44	0.05	0.04		
			ext. ovrhd.	44	0.05	0.04		
			1-77-1-A	46	0.05	0.04		
			1-82-3-L	35	0.05	0.04		
			1-82-1-L	35	0.05	0.04		
1-85-2-Q	1	0.43	1.25	1-85-1-L	1	0.43	1.25	
			4-82-0-E	1	0.43	1.25		
			1-82-0-L	1	0.43	1.25		
			1-82-0-L	1	0.43	1.25	Zero-Str	
			01-88-0-L	1	0.41	1.19		
			01-79-0B-L	1	0.41	1.19		
1-85-3-L	33	0.32	0.26	1-92-1-L	48	0.04	0.03	
			1-82-0-L	48	0.04	0.03		

-----Room of Origin-----				-----Barrier to Adjacent Room-----				
Plan ID	FRI Time	P(Loss) EB	RFL FFS (x 1000)	Adj. Room Plan ID	Fail Time	P(Loss) EB	RFL FFS (x 1000)	Opening/Zero-Str
1-102-0-E	2	0.20	5.37	1-85-1-L	59	0.04	0.03	
				1-85-1-L	59	0.04	0.03	
				1-82-3-L	59	0.04	0.03	
				1-82-1-L	59	0.04	0.03	
				1-102-2-A	2	0.20	5.37	Opening
				1-105-2-Q	30	0.02	0.59	
				1-98-1-L	30	0.02	0.59	
				1-96-1-L	30	0.02	0.59	
				1-96-0-L	30	0.02	0.59	
				ext. ovrhd.	30	0.02	0.59	
01-27-0-C	3	0.31	0.37	ext. blkhd.	25	0.02	0.58	
				ext. blkhd.	25	0.02	0.58	
				ext. blkhd.	25	0.02	0.58	
				ext. blkhd.	25	0.02	0.58	
				ext. blkhd.	25	0.02	0.58	
01-57-0-Q	2	0.17	0.43	ext. blkhd.	3	0.31	0.37	Opening
				ext. ovrhd.	4	0.14	0.17	
				ext. blkhd.	3	0.07	0.08	
				ext. blkhd.	3	0.07	0.08	
				ext. blkhd.	3	0.07	0.08	
01-68-0-Q	5	0.56	0.22	02-59-2-L	14	0.02	0.05	
				02-57-0-L	14	0.02	0.05	
				02-57-1-L	14	0.02	0.05	
				01-60-1-L	9	0.02	0.05	
				01-60-0C-L	9	0.02	0.05	
				01-57-2-L	9	0.02	0.05	
				01-74-1-L	14	0.07	0.03	
				01-60-0B-L	14	0.07	0.03	
				01-60-0A-L	14	0.07	0.03	
				02-73-0-Q	19	0.06	0.02	
01-68-1-L	5	0.49	0.20	02-66-0-C	19	0.06	0.02	
				02-56-0A-L	19	0.06	0.02	
				1-76-0-Q	52	0.06	0.02	
				01-74-1-L	20	0.06	0.02	
				01-68-1-L	20	0.06	0.02	
				01-74-1-L	5	0.49	0.20	Opening
				02-75-1-Q	8	0.08	0.03	
				02-69-1-L	8	0.08	0.03	
				02-57-0B-L	8	0.08	0.03	
				02-73-0-Q	8	0.08	0.03	
				02-66-1-L	8	0.08	0.03	
				02-66-0-C	8	0.08	0.03	
				02-57-0A-L	8	0.08	0.03	
				ext. ovrhd.	8	0.08	0.03	
				01-74-1-L	8	0.06	0.03	
01-68-0-Q	8	0.06	0.03					
01-78-3-E	2	0.18	3.77	ext. blkhd.	14	0.06	0.03	
				01-78-3-E	16	0.06	0.03	
				01-60-0B-L	18	0.05	0.02	
				1-77-3-L	39	0.05	0.02	
				1-66-3-Q	39	0.05	0.02	
				1-66-1-Q	39	0.05	0.02	
				1-66-0-L	39	0.05	0.02	
				01-79-0B-L	2	0.18	3.77	Opening
				01-79-0B-L	7	0.03	0.55	
				01-86-1-L	8	0.02	0.49	
1-80-1-Q	8	0.02	0.49					

-----Room of Origin-----				-----Barrier to Adjacent Room-----				
Plan ID	FRI Time	P(Loss) EB	RFL FFS (x 1000)	Adj. Room Plan ID	Room Fail Time	P(Loss) EB	RFL FFS (x 1000)	Opening/ Zero-Str
				1-80-1-Q	8	0.02	0.49	
				02-85-0-Q	8	0.02	0.49	
				01-78-1-F	8	0.02	0.49	
				1-76-0-Q	8	0.02	0.49	
				01-68-1-L	8	0.02	0.49	
				ext. blkhd.	8	0.02	0.49	
				ext. ovrhd.	8	0.02	0.49	
				1-85-1-L	21	0.02	0.38	
				1-82-3-L	21	0.02	0.38	
				1-82-1-L	21	0.02	0.38	
				1-77-3-L	21	0.02	0.38	
01-85-2-Q	1	0.61	0.61	01-88-2-L	6	0.07	0.07	
				01-84-2-L	6	0.07	0.07	
				01-84-2-L	6	0.07	0.07	
				01-79-0A-L	6	0.07	0.07	
				ext. ovrhd.	31	0.07	0.07	
02-57-0-L	26	0.41	0.33	03-56-0B-C	56	0.05	0.04	
				03-56-0A-C	56	0.05	0.04	
				02-61-2-L	44	0.04	0.04	
				02-59-2-L	44	0.04	0.04	
				02-59-2-L	44	0.04	0.04	
				02-57-0C-L	44	0.04	0.04	
				02-63-1-L	58	0.04	0.03	
				02-57-1-L	58	0.04	0.03	
02-57-0A-L	33	0.11	0.01	02-57-0C-L	33	0.11	0.01	Zero-Str
				02-57-0B-L	33	0.11	0.01	Zero-Str
				02-69-4-L	41	0.01	0.00	
				02-69-2-Q	41	0.01	0.00	
				02-66-0-C	41	0.01	0.00	
				03-56-0A-C	60	0.01	0.00	
02-57-4-L	31	0.41	0.33	02-63-2-L	57	0.05	0.04	
				02-57-2-L	57	0.05	0.04	
				02-57-2-L	57	0.05	0.04	
				02-57-0C-L	45	0.04	0.03	
02-66-0-C	5	0.49	0.59	03-66-01-C	38	0.05	0.06	
				03-66-0-L	38	0.05	0.06	
				03-56-0B-C	38	0.05	0.06	
				02-66-1-L	25	0.05	0.06	
				02-61-2-L	25	0.05	0.06	
				02-61-2-L	25	0.05	0.06	
				02-57-0C-L	25	0.05	0.06	
				02-57-0A-L	25	0.05	0.06	
02-73-0-Q	2	0.19	0.08	ext. blkhd.	2	0.19	0.08	Opening
				1-76-0-Q	8	0.05	0.02	
				1-76-0-Q	5	0.04	0.01	
				1-76-0-Q	5	0.04	0.01	
				03-76-0-Q	13	0.03	0.01	
				02-75-2-Q	15	0.02	0.00	
				02-69-4-L	15	0.02	0.00	
				ext. blkhd.	17	0.02	0.00	
				1-80-1-Q	17	0.02	0.00	
				02-57-0B-L	17	0.02	0.00	
				02-57-0A-L	17	0.02	0.00	
				ext. ovrhd.	17	0.02	0.00	
				01-71-2-L	50	0.02	0.00	

-----Room of Origin-----				-----Barrier to Adjacent Room-----				
Plan ID	FRI Time	P(Loss) EB	RFL FFS (x 1000)	Adj. Room Plan ID	Fail Time	P(Loss) EB	RFL FFS (x 1000)	Opening/ Zero-Str
02-75-1-Q	2	0.71	0.71	ext. blkhd.	2	0.71	0.71	Opening
				02-57-0B-L	2	0.21	0.21	
				02-69-1-L	5	0.15	0.15	
				ext. blkhd.	5	0.15	0.15	
				ext. ovrhd.	5	0.15	0.15	
02-75-2-Q	2	0.71	0.71	01-68-1-L	11	0.10	0.10	Opening
				ext. blkhd.	2	0.71	0.71	
				02-69-4-L	5	0.15	0.15	
				ext. blkhd.	5	0.15	0.15	
				ext. ovrhd.	5	0.15	0.15	
03-56-0A-C	9	0.39	0.47	02-73-0-Q	4	0.12	0.12	Zero-Str
				01-74-2-L	32	0.08	0.08	
				03-56-0B-C	9	0.39	0.47	
				ext. blkhd.	13	0.06	0.07	
				ext. blkhd.	13	0.06	0.07	
				ext. blkhd.	13	0.06	0.07	
				ext. blkhd.	13	0.06	0.07	
				ext. blkhd.	13	0.06	0.07	
				ext. blkhd.	13	0.06	0.07	
				ext. blkhd.	13	0.06	0.07	
				ext. blkhd.	13	0.06	0.07	
				ext. blkhd.	13	0.06	0.07	
				ext. blkhd.	13	0.06	0.07	
				ext. blkhd.	13	0.06	0.07	
				ext. blkhd.	13	0.06	0.07	
				ext. blkhd.	13	0.06	0.07	
				ext. blkhd.	13	0.06	0.07	
				ext. blkhd.	13	0.06	0.07	
				ext. ovrhd.	14	0.06	0.07	
				03-66-01-C	9	0.04	0.05	
				03-66-01-C	9	0.04	0.05	
				03-66-0-L	9	0.04	0.05	
				03-56-0B-C	9	0.04	0.05	
				02-57-2-L	18	0.04	0.05	
				02-69-4-L	60	0.04	0.05	
				02-66-2-L	60	0.04	0.05	
				02-63-2-L	60	0.04	0.05	
02-63-1-L	60	0.04	0.05					
02-57-4-L	60	0.04	0.05					
02-57-1-L	60	0.04	0.05					
02-57-0A-L	60	0.04	0.05					
02-69-2-Q	24	0.04	0.05					
02-61-2-L	24	0.04	0.05	Opening				
02-59-2-L	24	0.04	0.05					
02-57-0C-L	24	0.04	0.05					
02-57-0-L	24	0.04	0.05					
03-56-0B-C	5	0.39	0.47	03-56-0A-C	5	0.39	0.47	Zero-Str
				03-66-01-C	5	0.15	0.18	
				03-66-0-L	5	0.15	0.18	
				03-56-0A-C	5	0.15	0.18	
				ext. blkhd.	7	0.06	0.08	
				ext. blkhd.	7	0.06	0.08	
				ext. ovrhd.	7	0.06	0.08	
				02-69-1-L	30	0.04	0.05	
				02-63-1-L	30	0.04	0.05	
				02-57-0A-L	30	0.04	0.05	
				02-66-1-L	12	0.04	0.05	
				02-66-0-C	12	0.04	0.05	
				02-57-0-L	12	0.04	0.05	
03-66-01-C	5	0.46	0.56	03-66-0-L	51	0.05	0.06	
				03-66-0-L	51	0.05	0.06	
				03-56-0B-C	51	0.05	0.06	

-----Room of Origin-----				-----Barrier to Adjacent Room-----				
Plan ID	FRI Time	P(Loss) EB	RFL FFS (x 1000)	Adj. Room Plan ID	Fail Time	P(Loss) EB	RFL FFS (x 1000)	Opening/ Zero-Str
				03-56-0A-C	51	0.05	0.06	
				03-56-0A-C	51	0.05	0.06	
03-76-0-Q	2	0.78	1.01	ext. ovrhd.	9	0.12	0.15	
				ext. blkhd.	25	0.09	0.12	
				ext. blkhd.	25	0.09	0.12	
				ext. blkhd.	25	0.09	0.12	
				ext. blkhd.	25	0.09	0.12	

PATH OPTION - SUMMARY LEVEL REPORT

LISTING OF ALL PATHS FROM 4-66-0-E

READINESS CONDITION . YOKE
 CONFIGURATION Passive, Automatic, and Manual
 CASE Worst
 ASSUMED LOCATION . . . at SEA
 RUN TIME 60 minutes
 COMMENTS
 Ship Visit Baseline
 At Sea

```
*****
```

PATHS FROM 4-66-0-E				CUM L
1.	3-57-0-A			0.9334
2.	2-57-0-L			0.9843
3.	2-57-1-Q			0.9251
4.	2-57-4-E	2-57-2-A	2-48-2-E	0.9828
5.	2-57-4-E	2-57-2-A	1-60-2-A	0.9862
6.	2-57-4-E	2-57-2-A	1-60-4-A	0.9862
7.	2-57-4-E	1-60-6B-A		0.9606
8.	2-57-4-E	1-60-6B-A	1-60-2-A	0.9862
9.	2-57-4-E	1-60-6B-A	1-60-4-A	0.9862
10.	2-57-4-E	1-60-6B-A	01-83-2-L	0.9771
11.	2-59-1-Q			0.9251
12.	1-66-3-Q			0.9615
13.	1-60-6A-A			0.9334
14.	1-60-6A-A	01-70-2-Q		0.9525
15.	1-60-6A-A	1-60-6B-A		0.9631
16.	1-60-6A-A	1-60-6B-A	1-60-2-A	0.9871
17.	1-60-6A-A	1-60-6B-A	1-60-4-A	0.9871
18.	1-60-6A-A	1-60-6B-A	01-83-2-L	0.9786
19.	1-60-6A-A	1-71-2-Q	1-66-0-L	0.9841
20.	1-60-6A-A	1-71-2-Q	1-77-2-L	0.9889
21.	1-66-0-L			0.9242
22.	1-66-0-L	01-68-1-L		0.9808
23.	1-66-0-L	1-77-1-A		0.9799
24.	1-66-0-L	01-68-0-Q		0.9670
25.	1-66-0-L	1-66-1-Q		0.9679
26.	1-66-0-L	1-66-1-Q	1-66-0-L	0.9797
27.	1-66-0-L	1-66-1-Q	01-68-0-Q	0.9860
28.	1-66-1-Q			0.9491
29.	1-66-1-Q	1-66-0-L		0.9679
30.	1-66-1-Q	01-68-0-Q		0.9778
31.	1-71-2-Q	1-66-0-L		0.9713
32.	1-71-2-Q	1-66-0-L	1-66-1-Q	0.9878
33.	1-71-2-Q	1-74-2-Q		0.9824
34.	1-71-2-Q	1-77-2-L		0.9800
35.	1-74-2-Q			0.9422
36.	1-77-1-A			0.9143
37.	1-77-2-L			0.9263
38.	1-77-3-L	1-77-1-A		0.9780
39.	1-77-3-L	01-68-1-L		0.9769
40.	1-77-3-L	01-78-3-E		0.9866
41.	1-80-1-E			0.9597
42.	4-82-0-E	1-82-2-Q		0.9786
43.	4-82-0-E	1-85-2-Q		0.9751

PATHS FROM 4-66-0-E				CUM L
44.	4-82-0-E	1-85-2-Q	1-85-1-L	0.9875
45.	4-82-0-E	1-85-2-Q	01-88-0-L	0.9855
46.	4-82-0-E	2-89-1-C	1-66-0-L	0.9865
47.	4-82-0-E	2-89-1-C	1-77-3-L	0.9859
48.	4-82-0-E	1-76-0-Q		0.9594
49.	1-66-2-L			0.9876
50.	1-76-0-Q	1-77-1-A		0.9237
51.	1-76-0-Q	1-80-1-E		0.9641
52.	1-76-0-Q	01-68-0-Q	01-68-1-L	0.9704
53.	1-76-0-Q	01-68-0-Q	02-66-0-C	0.9681
54.	1-76-0-Q	01-68-0-Q	02-66-0-C 03-56-0B-C	0.9814
55.	1-76-0-Q	01-78-1-F		0.8931
56.	1-76-0-Q	01-78-3-E	01-68-1-L	0.9803
57.	1-76-0-Q	01-78-3-E	01-78-1-F	0.9504
58.	1-76-0-Q	01-78-3-E	01-86-1-L	0.9866
59.	1-76-0-Q	01-79-0A-L		0.9861
60.	1-76-0-Q	01-79-0B-L		0.9861
61.	1-76-0-Q	02-85-0-Q		0.9537
62.	1-76-0-Q	1-66-0-L		0.9325
63.	1-76-0-Q	1-66-0-L	01-68-1-L	0.9829
64.	1-76-0-Q	1-66-0-L	1-77-1-A	0.9821
65.	1-76-0-Q	1-66-0-L	01-68-0-Q	0.9706
66.	1-76-0-Q	1-66-0-L	1-66-1-Q	0.9714
67.	1-76-0-Q	1-66-0-L	1-66-1-Q 1-66-0-L	0.9819
68.	1-76-0-Q	1-66-0-L	1-66-1-Q 01-68-0-Q	0.9876
69.	1-76-0-Q	4-82-0-E		0.9864
70.	1-76-0-Q	4-82-0-E	1-76-0-Q	0.9879
71.	1-76-0-Q	01-60-0A-L		0.9861
72.	1-76-0-Q	01-74-1-L		0.9789
73.	1-76-0-Q	02-73-0-Q	03-76-0-Q	0.9720
74.	1-76-0-Q	03-76-0-Q		0.9087
75.	1-76-0-Q	1-80-1-Q	03-76-0-Q	0.9739
76.	2-89-1-C	1-66-0-L		0.9645
77.	2-89-1-C	1-66-0-L	01-68-0-Q	0.9845
78.	2-89-1-C	1-66-0-L	1-66-1-Q	0.9849
79.	2-89-1-C	1-66-3-Q		0.9879
80.	2-89-1-C	1-77-3-L	1-77-1-A	0.9892
81.	2-89-1-C	1-77-3-L	01-68-1-L	0.9887

PATH OPTION - SUMMARY LEVEL REPORT

LISTING OF ALL PATHS FROM 4-82-0-E

READINESS CONDITION . YOKE
 CONFIGURATION Passive, Automatic, and Manual
 CASE. Worst
 ASSUMED LOCATION. at SEA
 RUN TIME. 60 minutes
 COMMENTS.
 Ship Visit Baseline
 At Sea

```

*****
PATHS FROM 4-82-0-E                                CUM L
1.  1-82-2-Q                                        0.9395
2.  1-85-3-L                                        0.9746
3.  1-85-4-L                                        0.9746
4.  4-92-0-E                                        0.9864
5.  1-85-1-L                                        0.9746
6.  2-89-1-C      1-66-0-L                          0.9735
7.  2-89-1-C      1-66-0-L      01-68-0-Q           0.9885
8.  2-89-1-C      1-66-0-L      1-66-1-Q           0.9888
9.  2-89-1-C      1-77-3-L                          0.9735
10. 4-66-0-E      3-57-0-A                          0.9706
11. 4-66-0-E      2-57-1-Q                          0.9669
12. 4-66-0-E      2-57-4-E      2-57-2-A           0.9826
13. 4-66-0-E      2-57-4-E      1-60-6B-A          0.9826
14. 4-66-0-E      2-57-4-E      1-60-6B-A      01-83-2-L          0.9899
15. 4-66-0-E      2-59-1-Q                          0.9669
16. 4-66-0-E      1-60-6A-A                          0.9706
17. 4-66-0-E      1-60-6A-A      01-70-2-Q           0.9790
18. 4-66-0-E      1-60-6A-A      1-60-6B-A          0.9837
19. 4-66-0-E      1-60-6A-A      1-71-2-Q           0.9795
20. 4-66-0-E      1-66-0-L                          0.9771
21. 4-66-0-E      1-66-1-Q                          0.9893
22. 4-66-0-E      1-71-2-Q                          0.9710
23. 4-66-0-E      1-74-2-Q                          0.9816
24. 4-66-0-E      1-77-1-A                          0.9721
25. 4-66-0-E      1-77-2-L                          0.9794
26. 4-66-0-E      1-77-3-L                          0.9767
27. 1-76-0-Q      1-77-1-A      1-77-3-L           0.9847
28. 1-76-0-Q      1-80-1-E                          0.9614
29. 1-76-0-Q      01-68-0-Q      01-68-1-L           0.9682
30. 1-76-0-Q      01-68-0-Q      02-66-0-C           0.9658
31. 1-76-0-Q      01-68-0-Q      02-66-0-C      03-56-0B-C          0.9803
32. 1-76-0-Q      01-78-1-F                          0.8852
33. 1-76-0-Q      01-78-3-E      01-68-1-L           0.9789
34. 1-76-0-Q      01-78-3-E      01-78-1-F           0.9467
35. 1-76-0-Q      01-78-3-E      01-86-1-L           0.9856
36. 1-76-0-Q      01-79-0A-L                          0.9850
37. 1-76-0-Q      01-79-0B-L                          0.9850
38. 1-76-0-Q      02-85-0-Q                          0.9503
39. 1-76-0-Q      4-66-0-E      3-57-0-A           0.9738
40. 1-76-0-Q      4-66-0-E      2-57-1-Q           0.9706
41. 1-76-0-Q      4-66-0-E      2-57-4-E      2-57-2-A           0.9845
42. 1-76-0-Q      4-66-0-E      2-57-4-E      1-60-6B-A          0.9845
43. 1-76-0-Q      4-66-0-E      2-59-1-Q           0.9706
  
```

PATHS FROM 4-82-0-E

					CUM L
					0.9738
44.	1-76-0-Q	4-66-0-E	1-60-6A-A		0.9813
45.	1-76-0-Q	4-66-0-E	1-60-6A-A	01-70-2-Q	0.9855
46.	1-76-0-Q	4-66-0-E	1-60-6A-A	1-60-6B-A	0.9818
47.	1-76-0-Q	4-66-0-E	1-60-6A-A	1-71-2-Q	0.9796
48.	1-76-0-Q	4-66-0-E	1-66-0-L		0.9742
49.	1-76-0-Q	4-66-0-E	1-71-2-Q		0.9836
50.	1-76-0-Q	4-66-0-E	1-74-2-Q		0.9751
51.	1-76-0-Q	4-66-0-E	1-77-1-A		0.9817
52.	1-76-0-Q	4-66-0-E	1-77-2-L		0.9793
53.	1-76-0-Q	4-66-0-E	1-77-3-L		0.9714
54.	1-76-0-Q	4-66-0-E	2-89-1-C		0.9882
55.	1-76-0-Q	4-66-0-E	2-89-1-C	4-66-0-E	0.9275
56.	1-76-0-Q	1-66-0-L			0.9829
57.	1-76-0-Q	1-66-0-L	01-68-1-L		0.9821
58.	1-76-0-Q	1-66-0-L	1-77-1-A		0.9685
59.	1-76-0-Q	1-66-0-L	01-68-0-Q		0.9693
60.	1-76-0-Q	1-66-0-L	1-66-1-Q		0.9806
61.	1-76-0-Q	1-66-0-L	1-66-1-Q	1-66-0-L	0.9866
62.	1-76-0-Q	1-66-0-L	1-66-1-Q	01-68-0-Q	0.9850
63.	1-76-0-Q	01-60-0A-L			0.9774
64.	1-76-0-Q	01-74-1-L			0.9699
65.	1-76-0-Q	02-73-0-Q	03-76-0-Q		0.9019
66.	1-76-0-Q	03-76-0-Q			0.9719
67.	1-76-0-Q	1-80-1-Q	03-76-0-Q		0.9875
68.	1-82-0-L				0.9296
69.	1-85-2-Q				0.9647
70.	1-85-2-Q	1-85-1-L			0.9591
71.	1-85-2-Q	01-88-0-L			0.9866
72.	1-84-2-L				

PATH OPTION - SUMMARY LEVEL REPORT

LISTING OF ALL PATHS FROM 4-12-0-E

READINESS CONDITION . YOKE
CONFIGURATION Passive, Automatic, and Manual
CASE Worst
ASSUMED LOCATION at SEA
RUN TIME 60 minutes
COMMENTS
Ship Visit Baseline
At Sea

PATHS FROM 4-12-0-E		CUM L
1.		0.9110
2.	1-12-3-Q	0.9685
3.	1-18-1-Q	0.9621
4.	1-18-2-Q	0.9462
5.	1-18-2-Q 1-18-4-A	0.9702
6.	1-18-2-Q 1-19-2-T	0.9819
7.	1-18-2-Q 1-21-2-Q	0.9664
8.	1-18-4-A	0.9778
9.	2-21-1-A	0.9773
10.	2-21-2-Q	0.9617

WLB
07/02/96
MODEL RUN 23-166

PATH OPTION - SUMMARY LEVEL REPORT

LISTING OF ALL PATHS FROM 2-30-0-AA

READINESS CONDITION . YOKE
CONFIGURATION Passive, Automatic, and Manual
CASE. Worst
ASSUMED LOCATION. . . . at SEA
RUN TIME. 60 minutes
COMMENTS.
Ship Visit Baseline
At Sea

PATHS FROM 2-30-0-AA CUM L
No fire paths resulted from this model run

WLB
07/02/96
MODEL RUN 23-167

PATH OPTION - SUMMARY LEVEL REPORT

LISTING OF ALL PATHS FROM 1-85-3-L

READINESS CONDITION . YOKE
CONFIGURATION Passive, Automatic, and Manual
CASE Worst
ASSUMED LOCATION at SEA
RUN TIME 60 minutes
COMMENTS
Ship Visit Baseline
At Sea

PATHS FROM 1-85-3-L CUM L
1. 1-92-1-L 0.9803

PATH OPTION - DETAIL LEVEL REPORT

INFORMATION ON ALL PATHS FROM 4-66-0-E

READINESS CONDITION . YOKE
 CONFIGURATION Passive, Automatic, and Manual
 CASE Worst
 ASSUMED LOCATION at SEA
 RUN TIME 60 minutes
 COMMENTS
 Ship Visit Baseline
 At Sea

 Path no. 1 Path Length 2

Compt ID	Cum L	Ign Mode	EB Time	Compt Fuel	Therm IAM	Dur IAM	FRI Time	CBO
4-66-0-E	0.8799	orig	0	0.5	N/A	N/A	3	20
3-57-0-A	0.9334	therm	6	56.6	0.745	0.446	11	

Connecting Barrier	HEI	Tbar	Dbar	IBV	Time Destroyed	Failure Type
4-66-0-E/3-57-0-A	N/A	0.00	1.00	0.0000	25	dur

 Path no. 2 Path Length 2

Compt ID	Cum L	Ign Mode	EB Time	Compt Fuel	Therm IAM	Dur IAM	FRI Time	CBO
4-66-0-E	0.8799	orig	0	0.5	N/A	N/A	3	20
2-57-0-L	0.9843	dur	6	58.9	0.933	0.870	55	

Connecting Barrier	HEI	Tbar	Dbar	IBV	Time Destroyed	Failure Type
4-66-0-E/2-57-0-L	N/A	0.00	1.00	0.0000	42	dur

 Path no. 3 Path Length 2

Compt ID	Cum L	Ign Mode	EB Time	Compt Fuel	Therm IAM	Dur IAM	FRI Time	CBO
4-66-0-E	0.8799	orig	0	0.5	N/A	N/A	3	20
2-57-1-Q	0.9251	therm	6	54.7	0.646	0.376	12	

Connecting Barrier	HEI	Tbar	Dbar	IBV	Time Destroyed	Failure Type
4-66-0-E/2-57-1-Q	N/A	0.00	1.00	0.0000	27	dur

 Path no. 4 Path Length 4

Compt ID	Cum L	Ign Mode	EB Time	Compt Fuel	Therm IAM	Dur IAM	FRI Time	CBO
4-66-0-E	0.8799	orig	0	0.5	N/A	N/A	3	20
2-57-4-E	0.9290	therm	6	40.1	0.570	0.409	8	
2-57-2-A	0.9606	therm	46	0.0	0.745	0.446	50	54
2-48-2-E	0.9828	therm	46	42.8	0.794	0.562	48	

Connecting Barrier	HEI	Tbar	Dbar	IBV	Time Destroyed	Failure Type
4-66-0-E/2-57-4-E	N/A	0.00	1.00	0.0000	24	dur
2-57-4-E/2-57-2-A	N/A	0.00	1.00	0.0000	53	dur
2-57-2-A/2-48-2-E	N/A	0.00	1.00	0.0000	52	dur

 Path no. 5 Path Length 4

Compt ID	Cum L	Ign Mode	EB Time	Compt Fuel	Therm IAM	Dur IAM	FRI Time	CBO
4-66-0-E	0.8799	orig	0	0.5	N/A	N/A	3	20
2-57-4-E	0.9290	therm	6	40.1	0.570	0.409	8	
2-57-2-A	0.9606	therm	46	0.0	0.745	0.446	50	54
1-60-2-A	0.9862	dur	12	12.3	0.874	0.650	30	

Connecting Barrier	HEI	Tbar	Dbar	IBV	Time Destroyed	Failure Type
4-66-0-E/2-57-4-E	N/A	0.00	1.00	0.0000	24	dur
2-57-4-E/2-57-2-A	N/A	0.00	1.00	0.0000	53	dur
2-57-2-A/1-60-2-A	N/A	0.00	1.00	0.0000	55	dur

 Path no. 6 Path Length 4

Compt ID	Cum L	Ign Mode	EB Time	Compt Fuel	Therm IAM	Dur IAM	FRI Time	CBO
4-66-0-E	0.8799	orig	0	0.5	N/A	N/A	3	20
2-57-4-E	0.9290	therm	6	40.1	0.570	0.409	8	
2-57-2-A	0.9606	therm	46	0.0	0.745	0.446	50	54
1-60-4-A	0.9862	dur	12	16.1	0.874	0.650	30	

Connecting Barrier	HEI	Tbar	Dbar	IBV	Time Destroyed	Failure Type
4-66-0-E/2-57-4-E	N/A	0.00	1.00	0.0000	24	dur
2-57-4-E/2-57-2-A	N/A	0.00	1.00	0.0000	53	dur
2-57-2-A/1-60-4-A	N/A	0.00	1.00	0.0000	55	dur

 Path no. 7 Path Length 3

Compt ID	Cum L	Ign Mode	EB Time	Compt Fuel	Therm IAM	Dur IAM	FRI Time	CBO
4-66-0-E	0.8799	orig	0	0.5	N/A	N/A	3	20
2-57-4-E	0.9290	therm	6	40.1	0.570	0.409	8	
1-60-6B-A	0.9606	dur	10	0.0	0.745	0.446	11	14

Connecting

Time Failure

Barrier	HEI	Tbar	Dbar	IBV	Destroyed	Type
4-66-0-E/2-57-4-E	N/A	0.00	1.00	0.0000	24	dur
2-57-4-E/1-60-6B-A	N/A	0.00	1.00	0.0000	18	dur

 Path no. 8 Path Length 4

Compt ID	Cum L	Ign Mode	EB Time	Compt Fuel	Therm IAM	Dur IAM	FRI Time	CBO
4-66-0-E	0.8799	orig	0	0.5	N/A	N/A	3	20
2-57-4-E	0.9290	therm	6	40.1	0.570	0.409	8	
1-60-6B-A	0.9606	dur	10	0.0	0.745	0.446	11	14
1-60-2-A	0.9862	dur	12	12.3	0.874	0.650	30	

Connecting Barrier	HEI	Tbar	Dbar	IBV	Time Destroyed	Failure Type
4-66-0-E/2-57-4-E	N/A	0.00	1.00	0.0000	24	dur
2-57-4-E/1-60-6B-A	N/A	0.00	1.00	0.0000	18	dur
1-60-6B-A/1-60-2-A	N/A	0.00	1.00	0.0000	23	dur

 Path no. 9 Path Length 4

Compt ID	Cum L	Ign Mode	EB Time	Compt Fuel	Therm IAM	Dur IAM	FRI Time	CBO
4-66-0-E	0.8799	orig	0	0.5	N/A	N/A	3	20
2-57-4-E	0.9290	therm	6	40.1	0.570	0.409	8	
1-60-6B-A	0.9606	dur	10	0.0	0.745	0.446	11	14
1-60-4-A	0.9862	dur	12	16.1	0.874	0.650	30	

Connecting Barrier	HEI	Tbar	Dbar	IBV	Time Destroyed	Failure Type
4-66-0-E/2-57-4-E	N/A	0.00	1.00	0.0000	24	dur
2-57-4-E/1-60-6B-A	N/A	0.00	1.00	0.0000	18	dur
1-60-6B-A/1-60-4-A	N/A	0.00	1.00	0.0000	23	dur

 Path no. 10 Path Length 4

Compt ID	Cum L	Ign Mode	EB Time	Compt Fuel	Therm IAM	Dur IAM	FRI Time	CBO
4-66-0-E	0.8799	orig	0	0.5	N/A	N/A	3	20
2-57-4-E	0.9290	therm	6	40.1	0.570	0.409	8	
1-60-6B-A	0.9606	dur	10	0.0	0.745	0.446	11	14
01-83-2-L	0.9771	dur	12	44.5	0.730	0.419	30	

Connecting Barrier	HEI	Tbar	Dbar	IBV	Time Destroyed	Failure Type
4-66-0-E/2-57-4-E	N/A	0.00	1.00	0.0000	24	dur
2-57-4-E/1-60-6B-A	N/A	0.00	1.00	0.0000	18	dur
1-60-6B-A/01-83-2-L	N/A	0.00	1.00	0.0000	23	dur

 Path no. 11 Path Length 2

Compt	Ign	EB	Compt	Therm	Dur	FRI	CBO
-------	-----	----	-------	-------	-----	-----	-----

ID	Cum L	Mode	Time	Fuel	IAM	IAM	Time
4-66-0-E	0.8799	orig	0	0.5	N/A	N/A	3 20
2-59-1-Q	0.9251	therm	6	54.5	0.646	0.376	11

Connecting Barrier	HEI	Tbar	Dbar	IBV	Time Destroyed	Failure Type
4-66-0-E/2-59-1-Q	N/A	0.00	1.00	0.0000	26	dur

 Path no. 12 Path Length 2

Compt ID	Cum L	Ign Mode	EB Time	Compt Fuel	Therm IAM	Dur IAM	FRI Time	CBO
4-66-0-E	0.8799	orig	0	0.5	N/A	N/A	3	20
1-66-3-Q	0.9615	dur	6	30.4	0.924	0.661	57	

Connecting Barrier	HEI	Tbar	Dbar	IBV	Time Destroyed	Failure Type
4-66-0-E/1-66-3-Q	N/A	0.07	0.93	0.0000	42	dur

 Path no. 13 Path Length 2

Compt ID	Cum L	Ign Mode	EB Time	Compt Fuel	Therm IAM	Dur IAM	FRI Time	CBO
4-66-0-E	0.8799	orig	0	0.5	N/A	N/A	3	20
1-60-6A-A	0.9334	therm	6	6.2	0.745	0.446	10	12

Connecting Barrier	HEI	Tbar	Dbar	IBV	Time Destroyed	Failure Type
4-66-0-E/1-60-6A-A	N/A	0.00	1.00	0.0000	15	dur

 Path no. 14 Path Length 3

Compt ID	Cum L	Ign Mode	EB Time	Compt Fuel	Therm IAM	Dur IAM	FRI Time	CBO
4-66-0-E	0.8799	orig	0	0.5	N/A	N/A	3	20
1-60-6A-A	0.9334	therm	6	6.2	0.745	0.446	10	12
01-70-2-Q	0.9525	dur	11	14.5	0.531	0.286	29	

Connecting Barrier	HEI	Tbar	Dbar	IBV	Time Destroyed	Failure Type
4-66-0-E/1-60-6A-A	N/A	0.00	1.00	0.0000	15	dur
1-60-6A-A/01-70-2-Q	N/A	0.00	1.00	0.0000	22	dur

 Path no. 15 Path Length 3

Compt ID	Cum L	Ign Mode	EB Time	Compt Fuel	Therm IAM	Dur IAM	FRI Time	CBO
4-66-0-E	0.8799	orig	0	0.5	N/A	N/A	3	20
1-60-6A-A	0.9334	therm	6	6.2	0.745	0.446	10	12

1-60-6B-A 0.9631 dur 10 0.0 0.745 0.446 11 14

Connecting Barrier	HEI	Tbar	Dbar	IBV	Time Destroyed	Failure Type
4-66-0-E/1-60-6A-A	N/A	0.00	1.00	0.0000	15	dur
1-60-6A-A/1-60-6B-A	N/A	0.00	1.00	0.0000	10	dur

 Path no. 16 Path Length 4

Compt ID	Cum L	Ign Mode	EB Time	Compt Fuel	Therm IAM	Dur IAM	FRI Time	CBO
4-66-0-E	0.8799	orig	0	0.5	N/A	N/A	3	20
1-60-6A-A	0.9334	therm	6	6.2	0.745	0.446	10	12
1-60-6B-A	0.9631	dur	10	0.0	0.745	0.446	11	14
1-60-2-A	0.9871	dur	12	12.3	0.874	0.650	30	

Connecting Barrier	HEI	Tbar	Dbar	IBV	Time Destroyed	Failure Type
4-66-0-E/1-60-6A-A	N/A	0.00	1.00	0.0000	15	dur
1-60-6A-A/1-60-6B-A	N/A	0.00	1.00	0.0000	10	dur
1-60-6B-A/1-60-2-A	N/A	0.00	1.00	0.0000	23	dur

 Path no. 17 Path Length 4

Compt ID	Cum L	Ign Mode	EB Time	Compt Fuel	Therm IAM	Dur IAM	FRI Time	CBO
4-66-0-E	0.8799	orig	0	0.5	N/A	N/A	3	20
1-60-6A-A	0.9334	therm	6	6.2	0.745	0.446	10	12
1-60-6B-A	0.9631	dur	10	0.0	0.745	0.446	11	14
1-60-4-A	0.9871	dur	12	16.1	0.874	0.650	30	

Connecting Barrier	HEI	Tbar	Dbar	IBV	Time Destroyed	Failure Type
4-66-0-E/1-60-6A-A	N/A	0.00	1.00	0.0000	15	dur
1-60-6A-A/1-60-6B-A	N/A	0.00	1.00	0.0000	10	dur
1-60-6B-A/1-60-4-A	N/A	0.00	1.00	0.0000	23	dur

 Path no. 18 Path Length 4

Compt ID	Cum L	Ign Mode	EB Time	Compt Fuel	Therm IAM	Dur IAM	FRI Time	CBO
4-66-0-E	0.8799	orig	0	0.5	N/A	N/A	3	20
1-60-6A-A	0.9334	therm	6	6.2	0.745	0.446	10	12
1-60-6B-A	0.9631	dur	10	0.0	0.745	0.446	11	14
01-83-2-L	0.9786	dur	12	44.5	0.730	0.419	30	

Connecting Barrier	HEI	Tbar	Dbar	IBV	Time Destroyed	Failure Type
4-66-0-E/1-60-6A-A	N/A	0.00	1.00	0.0000	15	dur
1-60-6A-A/1-60-6B-A	N/A	0.00	1.00	0.0000	10	dur
1-60-6B-A/01-83-2-L	N/A	0.00	1.00	0.0000	23	dur

 Path no. 19 Path Length 4

Compt ID	Cum L	Ign Mode	EB Time	Compt Fuel	Therm IAM	Dur IAM	FRI Time	CBO
4-66-0-E	0.8799	orig	0	0.5	N/A	N/A	3	20
1-60-6A-A	0.9334	therm	6	6.2	0.745	0.446	10	12
1-71-2-Q	0.9536	therm	6	33.6	0.565	0.303	11	
1-66-0-L	0.9841	dur	4	20.2	0.657	0.369	27	

Connecting Barrier	HEI	Tbar	Dbar	IBV	Time Destroyed	Failure Type
4-66-0-E/1-60-6A-A	N/A	0.00	1.00	0.0000	15	dur
1-60-6A-A/1-71-2-Q	N/A	0.00	1.00	0.0000	15	dur
1-71-2-Q/1-66-0-L	13.4	1.00	0.00	0.0000		therm

 Path no. 20 Path Length 4

Compt ID	Cum L	Ign Mode	EB Time	Compt Fuel	Therm IAM	Dur IAM	FRI Time	CBO
4-66-0-E	0.8799	orig	0	0.5	N/A	N/A	3	20
1-60-6A-A	0.9334	therm	6	6.2	0.745	0.446	10	12
1-71-2-Q	0.9536	therm	6	33.6	0.565	0.303	11	
1-77-2-L	0.9889	dur	6	63.3	0.657	0.369	57	

Connecting Barrier	HEI	Tbar	Dbar	IBV	Time Destroyed	Failure Type
4-66-0-E/1-60-6A-A	N/A	0.00	1.00	0.0000	15	dur
1-60-6A-A/1-71-2-Q	N/A	0.00	1.00	0.0000	15	dur
1-71-2-Q/1-77-2-L	6.3	0.69	0.00	0.0142		therm

 Path no. 21 Path Length 2

Compt ID	Cum L	Ign Mode	EB Time	Compt Fuel	Therm IAM	Dur IAM	FRI Time	CBO
4-66-0-E	0.8799	orig	0	0.5	N/A	N/A	3	20
1-66-0-L	0.9242	dur	4	20.2	0.657	0.369	27	

Connecting Barrier	HEI	Tbar	Dbar	IBV	Time Destroyed	Failure Type
4-66-0-E/1-66-0-L	N/A	0.00	1.00	0.0000	40	dur

 Path no. 22 Path Length 3

Compt ID	Cum L	Ign Mode	EB Time	Compt Fuel	Therm IAM	Dur IAM	FRI Time	CBO
4-66-0-E	0.8799	orig	0	0.5	N/A	N/A	3	20
1-66-0-L	0.9242	dur	4	20.2	0.657	0.369	27	
01-68-1-L	0.9808	therm	22	70.9	0.603	0.344	27	

Connecting Barrier	HEI	Tbar	Dbar	IBV	Time Destroyed	Failure Type

4-66-0-E/1-66-0-L	N/A	0.00	1.00	0.0000	40	dur
1-66-0-L/01-68-1-L	7.0	0.64	0.00	0.0274		therm

 Path no. 23 Path Length 3

Compt ID	Cum L	Ign Mode	EB Time	Compt Fuel	Therm IAM	Dur IAM	FRI Time	CBO
4-66-0-E	0.8799	orig	0	0.5	N/A	N/A	3	20
1-66-0-L	0.9242	dur	4	20.2	0.657	0.369	27	
1-77-1-A	0.9799	therm	5	135.9	0.531	0.286	32	

Connecting Barrier	HEI	Tbar	Dbar	IBV	Time Destroyed	Failure Type
4-66-0-E/1-66-0-L	N/A	0.00	1.00	0.0000	40	dur
1-66-0-L/1-77-1-A	4.9	0.57	0.00	0.0329		therm

 Path no. 24 Path Length 3

Compt ID	Cum L	Ign Mode	EB Time	Compt Fuel	Therm IAM	Dur IAM	FRI Time	CBO
4-66-0-E	0.8799	orig	0	0.5	N/A	N/A	3	20
1-66-0-L	0.9242	dur	4	20.2	0.657	0.369	27	
01-68-0-Q	0.9670	therm	5	94.2	0.565	0.303	10	

Connecting Barrier	HEI	Tbar	Dbar	IBV	Time Destroyed	Failure Type
4-66-0-E/1-66-0-L	N/A	0.00	1.00	0.0000	40	dur
1-66-0-L/01-68-0-Q	17.4	1.00	0.00	0.0000		therm

 Path no. 25 Path Length 3

Compt ID	Cum L	Ign Mode	EB Time	Compt Fuel	Therm IAM	Dur IAM	FRI Time	CBO
4-66-0-E	0.8799	orig	0	0.5	N/A	N/A	3	20
1-66-0-L	0.9242	dur	4	20.2	0.657	0.369	27	
1-66-1-Q	0.9679	dur	6	4.2	0.866	0.576	31	

Connecting Barrier	HEI	Tbar	Dbar	IBV	Time Destroyed	Failure Type
4-66-0-E/1-66-0-L	N/A	0.00	1.00	0.0000	40	dur
1-66-0-L/1-66-1-Q	0.1	0.00	1.00	0.0000	27	dur

 Path no. 26 Path Length 4

Compt ID	Cum L	Ign Mode	EB Time	Compt Fuel	Therm IAM	Dur IAM	FRI Time	CBO
4-66-0-E	0.8799	orig	0	0.5	N/A	N/A	3	20
1-66-0-L	0.9242	dur	4	20.2	0.657	0.369	27	
1-66-1-Q	0.9679	dur	6	4.2	0.866	0.576	31	
1-66-0-L	0.9797	dur	4	20.2	0.657	0.369	27	

Connecting Barrier	HEI	Tbar	Dbar	IBV	Time Destroyed	Failure Type
4-66-0-E/1-66-0-L	N/A	0.00	1.00	0.0000	40	dur
1-66-0-L/1-66-1-Q	0.1	0.00	1.00	0.0000	27	dur
1-66-1-Q/1-66-0-L	0.1	0.00	1.00	0.0000	27	dur

 Path no. 27 Path Length 4

Compt ID	Cum L	Ign Mode	EB Time	Compt Fuel	Therm IAM	Dur IAM	FRI Time	CBO
4-66-0-E	0.8799	orig	0	0.5	N/A	N/A	3	20
1-66-0-L	0.9242	dur	4	20.2	0.657	0.369	27	
1-66-1-Q	0.9679	dur	6	4.2	0.866	0.576	31	
01-68-0-Q	0.9860	therm	5	94.2	0.565	0.303	10	

Connecting Barrier	HEI	Tbar	Dbar	IBV	Time Destroyed	Failure Type
4-66-0-E/1-66-0-L	N/A	0.00	1.00	0.0000	40	dur
1-66-0-L/1-66-1-Q	0.1	0.00	1.00	0.0000	27	dur
1-66-1-Q/01-68-0-Q	14.5	1.00	0.00	0.0000		therm

 Path no. 28 Path Length 2

Compt ID	Cum L	Ign Mode	EB Time	Compt Fuel	Therm IAM	Dur IAM	FRI Time	CBO
4-66-0-E	0.8799	orig	0	0.5	N/A	N/A	3	20
1-66-1-Q	0.9491	dur	6	4.2	0.866	0.576	31	

Connecting Barrier	HEI	Tbar	Dbar	IBV	Time Destroyed	Failure Type
4-66-0-E/1-66-1-Q	N/A	0.00	1.00	0.0000	41	dur

 Path no. 29 Path Length 3

Compt ID	Cum L	Ign Mode	EB Time	Compt Fuel	Therm IAM	Dur IAM	FRI Time	CBO
4-66-0-E	0.8799	orig	0	0.5	N/A	N/A	3	20
1-66-1-Q	0.9491	dur	6	4.2	0.866	0.576	31	
1-66-0-L	0.9679	dur	4	20.2	0.657	0.369	27	

Connecting Barrier	HEI	Tbar	Dbar	IBV	Time Destroyed	Failure Type
4-66-0-E/1-66-1-Q	N/A	0.00	1.00	0.0000	41	dur
1-66-1-Q/1-66-0-L	0.1	0.00	1.00	0.0000	27	dur

 Path no. 30 Path Length 3

Compt ID	Cum L	Ign Mode	EB Time	Compt Fuel	Therm IAM	Dur IAM	FRI Time	CBO
4-66-0-E	0.8799	orig	0	0.5	N/A	N/A	3	20

1-66-1-Q	0.9491	dur	6	4.2	0.866	0.576	31
1-66-0-Q	0.9778	therm	5	34.2	0.565	0.303	10

Connecting Barrier	HEI	Tbar	Dbar	IBV	Time Destroyed	Failure Type
4-66-0-E/1-66-1-Q	N/A	0.00	1.00	0.0000	41	dur
1-66-1-Q/01-68-0-Q	14.5	1.00	0.00	0.0000		therm

.....
 Path no. 31 Path Length 3

Compt ID	Cum L	Ign Mode	EB Time	Compt Fuel	Therm IAM	Dur IAM	FRI Time	CBO
4-66-0-E	0.8799	orig	0	0.5	N/A	N/A	3	20
1-71-2-Q	0.9163	therm	6	33.6	0.565	0.303	11	
1-66-0-L	0.9713	dur	4	20.2	0.657	0.369	27	

Connecting Barrier	HEI	Tbar	Dbar	IBV	Time Destroyed	Failure Type
4-66-0-E/1-71-2-Q	N/A	0.00	1.00	0.0000	37	dur
1-71-2-Q/1-66-0-L	13.4	1.00	0.00	0.0000		therm

.....
 Path no. 32 Path Length 4

Compt ID	Cum L	Ign Mode	EB Time	Compt Fuel	Therm IAM	Dur IAM	FRI Time	CBO
4-66-0-E	0.8799	orig	0	0.5	N/A	N/A	3	20
1-71-2-Q	0.9163	therm	6	33.6	0.565	0.303	11	
1-66-0-L	0.9713	dur	4	20.2	0.657	0.369	27	
1-66-1-Q	0.9878	dur	6	4.2	0.866	0.576	31	

Connecting Barrier	HEI	Tbar	Dbar	IBV	Time Destroyed	Failure Type
4-66-0-E/1-71-2-Q	N/A	0.00	1.00	0.0000	37	dur
1-71-2-Q/1-66-0-L	13.4	1.00	0.00	0.0000		therm
1-66-0-L/1-66-1-Q	0.1	0.00	1.00	0.0000	27	dur

.....
 Path no. 33 Path Length 3

Compt ID	Cum L	Ign Mode	EB Time	Compt Fuel	Therm IAM	Dur IAM	FRI Time	CBO
4-66-0-E	0.8799	orig	0	0.5	N/A	N/A	3	20
1-71-2-Q	0.9163	therm	6	33.6	0.565	0.303	11	
1-74-2-Q	0.9824	dur	6	60.1	0.680	0.506	57	

Connecting Barrier	HEI	Tbar	Dbar	IBV	Time Destroyed	Failure Type
4-66-0-E/1-71-2-Q	N/A	0.00	1.00	0.0000	37	dur
1-71-2-Q/1-74-2-Q	5.9	0.66	0.00	0.0288		therm

.....
 Path no. 34 Path Length 3

Compt ID	Cum L	Ign Mode	EB Time	Compt Fuel	Therm IAM	Dur IAM	FRI Time	CBO
4-66-0-E	0.8799	orig	0	0.5	N/A	N/A	3	20
1-71-2-Q	0.9163	therm	6	33.6	0.565	0.303	11	
1-77-2-L	0.9800	dur	6	63.3	0.657	0.369	57	

Connecting Barrier	HEI	Tbar	Dbar	IBV	Time Destroyed	Failure Type
4-66-0-E/1-71-2-Q	N/A	0.00	1.00	0.0000	37	dur
1-71-2-Q/1-77-2-L	6.3	0.69	0.00	0.0255		therm

Path no. 35 Path Length 2

Compt ID	Cum L	Ign Mode	EB Time	Compt Fuel	Therm IAM	Dur IAM	FRI Time	CBO
4-66-0-E	0.8799	orig	0	0.5	N/A	N/A	3	20
1-74-2-Q	0.9422	dur	6	60.1	0.680	0.506	57	

Connecting Barrier	HEI	Tbar	Dbar	IBV	Time Destroyed	Failure Type
4-66-0-E/1-74-2-Q	N/A	0.07	0.93	0.0000	42	dur

Path no. 36 Path Length 2

Compt ID	Cum L	Ign Mode	EB Time	Compt Fuel	Therm IAM	Dur IAM	FRI Time	CBO
4-66-0-E	0.8799	orig	0	0.5	N/A	N/A	3	20
1-77-1-A	0.9143	therm	5	135.9	0.531	0.286	32	

Connecting Barrier	HEI	Tbar	Dbar	IBV	Time Destroyed	Failure Type
4-66-0-E/1-77-1-A	N/A	0.00	1.00	0.0000	41	dur

Path no. 37 Path Length 2

Compt ID	Cum L	Ign Mode	EB Time	Compt Fuel	Therm IAM	Dur IAM	FRI Time	CBO
4-66-0-E	0.8799	orig	0	0.5	N/A	N/A	3	20
1-77-2-L	0.9263	dur	6	63.3	0.657	0.369	57	

Connecting Barrier	HEI	Tbar	Dbar	IBV	Time Destroyed	Failure Type
4-66-0-E/1-77-2-L	N/A	0.06	0.94	0.0000	42	dur

Path no. 38 Path Length 3

Compt ID	Cum L	Ign Mode	EB Time	Compt Fuel	Therm IAM	Dur IAM	FRI Time	CBO
4-66-0-E	0.8799	orig	0	0.5	N/A	N/A	3	20

1-77-3-L	0.9242	therm	6	57.2	0.657	0.369	27
1-77-1-A	0.9780	therm	5	135.9	0.531	0.286	32

Connecting Barrier	HEI	Tbar	Dbar	IBV	Time Destroyed	Failure Type
4-66-0-E/1-77-3-L	N/A	0.00	1.00	0.0000	40	dur
1-77-3-L/1-77-1-A	7.9	0.62	0.00	0.0289		therm

 Path no. 39 Path Length 3

Compt ID	Cum L	Ign Mode	EB Time	Compt Fuel	Therm IAM	Dur IAM	FRI Time	CBO
4-66-0-E	0.8799	orig	0	0.5	N/A	N/A	3	20
1-77-3-L	0.9242	therm	6	57.2	0.657	0.369	27	
01-68-1-L	0.9769	therm	22	70.9	0.603	0.344	27	

Connecting Barrier	HEI	Tbar	Dbar	IBV	Time Destroyed	Failure Type
4-66-0-E/1-77-3-L	N/A	0.00	1.00	0.0000	40	dur
1-77-3-L/01-68-1-L	8.8	0.77	0.00	0.0177		therm

 Path no. 40 Path Length 3

Compt ID	Cum L	Ign Mode	EB Time	Compt Fuel	Therm IAM	Dur IAM	FRI Time	CBO
4-66-0-E	0.8799	orig	0	0.5	N/A	N/A	3	20
1-77-3-L	0.9242	therm	6	57.2	0.657	0.369	27	
01-78-3-E	0.9866	therm	5	8.4	0.824	0.536	7	

Connecting Barrier	HEI	Tbar	Dbar	IBV	Time Destroyed	Failure Type
4-66-0-E/1-77-3-L	N/A	0.00	1.00	0.0000	40	dur
1-77-3-L/01-78-3-E	50.6	1.00	0.00	0.0000		therm

 Path no. 41 Path Length 2

Compt ID	Cum L	Ign Mode	EB Time	Compt Fuel	Therm IAM	Dur IAM	FRI Time	CBO
4-66-0-E	0.8799	orig	0	0.5	N/A	N/A	3	20
1-80-1-E	0.9597	dur	5	35.5	1.000	0.664	33	

Connecting Barrier	HEI	Tbar	Dbar	IBV	Time Destroyed	Failure Type
4-66-0-E/1-80-1-E	N/A	0.00	1.00	0.0000	41	dur

 Path no. 42 Path Length 3

Compt ID	Cum L	Ign Mode	EB Time	Compt Fuel	Therm IAM	Dur IAM	FRI Time	CBO
4-66-0-E	0.8799	orig	0	0.5	N/A	N/A	3	20

4-82-0-E	0.9543	therm	4	0.0	0.873	0.620	7	52
1-82-2-Q	0.9786	therm	19	5.2	0.531	0.286		

Connecting Barrier	HEI	Tbar	Dbar	IBV	Time Destroyed	Failure Type
4-66-0-E/4-82-0-E	N/A	0.00	1.00	0.0000	20	dur
4-82-0-E/1-82-2-Q	N/A	1.00	0.00	0.0000		therm

 Path no. 43 Path Length 3

Compt ID	Cum L	Ign Mode	EB Time	Compt Fuel	Therm IAM	Dur IAM	FRI Time	CBO
4-66-0-E	0.8799	orig	0	0.5	N/A	N/A	3	20
4-82-0-E	0.9543	therm	4	0.0	0.873	0.620	7	52
1-85-2-Q	0.9751	therm	9	0.1	0.620	0.454	10	12

Connecting Barrier	HEI	Tbar	Dbar	IBV	Time Destroyed	Failure Type
4-66-0-E/4-82-0-E	N/A	0.00	1.00	0.0000	20	dur
4-82-0-E/1-85-2-Q	N/A	0.00	1.00	0.0000	13	dur

 Path no. 44 Path Length 4

Compt ID	Cum L	Ign Mode	EB Time	Compt Fuel	Therm IAM	Dur IAM	FRI Time	CBO
4-66-0-E	0.8799	orig	0	0.5	N/A	N/A	3	20
4-82-0-E	0.9543	therm	4	0.0	0.873	0.620	7	52
1-85-2-Q	0.9751	therm	9	0.1	0.620	0.454	10	12
1-85-1-L	0.9875	dur	10	50.4	0.803	0.500	21	

Connecting Barrier	HEI	Tbar	Dbar	IBV	Time Destroyed	Failure Type
4-66-0-E/4-82-0-E	N/A	0.00	1.00	0.0000	20	dur
4-82-0-E/1-85-2-Q	N/A	0.00	1.00	0.0000	13	dur
1-85-2-Q/1-85-1-L	N/A	0.00	1.00	0.0000	15	dur

 Path no. 45 Path Length 4

Compt ID	Cum L	Ign Mode	EB Time	Compt Fuel	Therm IAM	Dur IAM	FRI Time	CBO
4-66-0-E	0.8799	orig	0	0.5	N/A	N/A	3	20
4-82-0-E	0.9543	therm	4	0.0	0.873	0.620	7	52
1-85-2-Q	0.9751	therm	9	0.1	0.620	0.454	10	12
01-88-0-L	0.9855	dur	10	43.2	0.730	0.419	21	

Connecting Barrier	HEI	Tbar	Dbar	IBV	Time Destroyed	Failure Type
4-66-0-E/4-82-0-E	N/A	0.00	1.00	0.0000	20	dur
4-82-0-E/1-85-2-Q	N/A	0.00	1.00	0.0000	13	dur
1-85-2-Q/01-88-0-L	N/A	0.00	1.00	0.0000	16	dur

Path no. 46 Path Length 4

Compt ID	Cum L	Ign Mode	EB Time	Compt Fuel	Therm IAM	Dur IAM	FRI Time	CBO
4-66-0-E	0.8799	orig	0	0.5	N/A	N/A	3	20
4-82-0-E	0.9543	therm	4	0.0	0.873	0.620	7	52
2-89-1-C	0.9723	dur	3	0.0	0.655	0.394	4	31
1-66-0-L	0.9865	dur	4	20.2	0.657	0.369	27	

Connecting Barrier	HEI	Tbar	Dbar	IBV	Time Destroyed	Failure Type
4-66-0-E/4-82-0-E	N/A	0.00	1.00	0.0000	20	dur
4-82-0-E/2-89-1-C	N/A	0.00	1.00	0.0000	23	dur
2-89-1-C/1-66-0-L	110.4	0.50	0.50	0.0000	49	dur

Path no. 47 Path Length 4

Compt ID	Cum L	Ign Mode	EB Time	Compt Fuel	Therm IAM	Dur IAM	FRI Time	CBO
4-66-0-E	0.8799	orig	0	0.5	N/A	N/A	3	20
4-82-0-E	0.9543	therm	4	0.0	0.873	0.620	7	52
2-89-1-C	0.9723	dur	3	0.0	0.655	0.394	4	31
1-77-3-L	0.9859	therm	6	57.2	0.657	0.369	27	

Connecting Barrier	HEI	Tbar	Dbar	IBV	Time Destroyed	Failure Type
4-66-0-E/4-82-0-E	N/A	0.00	1.00	0.0000	20	dur
4-82-0-E/2-89-1-C	N/A	0.00	1.00	0.0000	23	dur
2-89-1-C/1-77-3-L	113.6	0.42	0.58	0.0000	48	dur

Path no. 48 Path Length 3

Compt ID	Cum L	Ign Mode	EB Time	Compt Fuel	Therm IAM	Dur IAM	FRI Time	CBO
4-66-0-E	0.8799	orig	0	0.5	N/A	N/A	3	20
4-82-0-E	0.9543	therm	4	0.0	0.873	0.620	7	52
1-76-0-Q	0.9594	dur	3	0.0	0.200	0.110	4	11

Connecting Barrier	HEI	Tbar	Dbar	IBV	Time Destroyed	Failure Type
4-66-0-E/4-82-0-E	N/A	0.00	1.00	0.0000	20	dur
4-82-0-E/1-76-0-Q	N/A	0.00	1.00	0.0000	13	dur

Path no. 49 Path Length 2

Compt ID	Cum L	Ign Mode	EB Time	Compt Fuel	Therm IAM	Dur IAM	FRI Time	CBO
4-66-0-E	0.8799	orig	0	0.5	N/A	N/A	3	20
1-66-2-L	0.9876	dur	3	12.0	0.955	0.897	7	

Connecting Barrier	HEI	Tbar	Dbar	IBV	Time Destroyed	Failure Type
--------------------	-----	------	------	-----	----------------	--------------

4-66-0-E/1-66-2-L N/A 0.00 1.00 0.0000 3 dur

 Path no. 50 Path Length 3

Compt ID	Cum L	Ign Mode	EB Time	Compt Fuel	Therm IAM	Dur IAM	FRI Time	CBO
4-66-0-E	0.8799	orig	0	0.5	N/A	N/A	3	20
1-76-0-Q	0.8931	dur	3	0.0	0.200	0.110	4	11
1-77-1-A	0.9237	therm	5	135.9	0.531	0.286	32	

Connecting Barrier	HEI	Tbar	Dbar	IBV	Time Destroyed	Failure Type
4-66-0-E/1-76-0-Q	N/A	0.00	1.00	0.0000	3	dur
1-76-0-Q/1-77-1-A	N/A	0.00	1.00	0.0000	23	dur

 Path no. 51 Path Length 3

Compt ID	Cum L	Ign Mode	EB Time	Compt Fuel	Therm IAM	Dur IAM	FRI Time	CBO
4-66-0-E	0.8799	orig	0	0.5	N/A	N/A	3	20
1-76-0-Q	0.8931	dur	3	0.0	0.200	0.110	4	11
1-80-1-E	0.9641	dur	5	35.5	1.000	0.664	33	

Connecting Barrier	HEI	Tbar	Dbar	IBV	Time Destroyed	Failure Type
4-66-0-E/1-76-0-Q	N/A	0.00	1.00	0.0000	3	dur
1-76-0-Q/1-80-1-E	N/A	0.00	1.00	0.0000	23	dur

 Path no. 52 Path Length 4

Compt ID	Cum L	Ign Mode	EB Time	Compt Fuel	Therm IAM	Dur IAM	FRI Time	CBO
4-66-0-E	0.8799	orig	0	0.5	N/A	N/A	3	20
1-76-0-Q	0.8931	dur	3	0.0	0.200	0.110	4	11
01-68-0-Q	0.9255	therm	5	94.2	0.565	0.303	10	
01-68-1-L	0.9704	therm	22	70.9	0.603	0.344	27	

Connecting Barrier	HEI	Tbar	Dbar	IBV	Time Destroyed	Failure Type
4-66-0-E/1-76-0-Q	N/A	0.00	1.00	0.0000	3	dur
1-76-0-Q/01-68-0-Q	N/A	0.00	1.00	0.0000	16	dur
01-68-0-Q/01-68-1-L	N/A	1.00	0.00	0.0000		therm

 Path no. 53 Path Length 4

Compt ID	Cum L	Ign Mode	EB Time	Compt Fuel	Therm IAM	Dur IAM	FRI Time	CBO
4-66-0-E	0.8799	orig	0	0.5	N/A	N/A	3	20
1-76-0-Q	0.8931	dur	3	0.0	0.200	0.110	4	11
01-68-0-Q	0.9255	therm	5	94.2	0.565	0.303	10	
02-66-0-C	0.9681	therm	24	76.4	0.572	0.344	29	

Connecting Barrier	HEI	Tbar	Dbar	IBV	Time Destroyed	Failure Type
4-66-0-E/1-76-0-Q	N/A	0.00	1.00	0.0000	3	dur
1-76-0-Q/01-68-0-Q	N/A	0.00	1.00	0.0000	16	dur
01-68-0-Q/02-66-0-C	N/A	1.00	0.00	0.0000		therm

Path no. 54 Path Length 5

Compt ID	Cum L	Ign Mode	EB Time	Compt Fuel	Therm IAM	Dur IAM	FRI Time	CBO
4-66-0-E	0.8799	orig	0	0.5	N/A	N/A	3	20
1-76-0-Q	0.8931	dur	3	0.0	0.200	0.110	4	11
01-68-0-Q	0.9255	therm	5	94.2	0.565	0.303	10	
02-66-0-C	0.9681	therm	24	76.4	0.572	0.344	29	
03-56-0B-C	0.9814	dur	40	0.0	0.690	0.418	41	56

Connecting Barrier	HEI	Tbar	Dbar	IBV	Time Destroyed	Failure Type
4-66-0-E/1-76-0-Q	N/A	0.00	1.00	0.0000	3	dur
1-76-0-Q/01-68-0-Q	N/A	0.00	1.00	0.0000	16	dur
01-68-0-Q/02-66-0-C	N/A	1.00	0.00	0.0000		therm
02-66-0-C/03-56-0B-C	125.6	0.00	1.00	0.0000	52	dur

Path no. 55 Path Length 3

Compt ID	Cum L	Ign Mode	EB Time	Compt Fuel	Therm IAM	Dur IAM	FRI Time	CBO
4-66-0-E	0.8799	orig	0	0.5	N/A	N/A	3	20
1-76-0-Q	0.8931	dur	3	0.0	0.200	0.110	4	11
01-78-1-F	0.8931	dur	5	73.9	0.000	0.000		5

Connecting Barrier	HEI	Tbar	Dbar	IBV	Time Destroyed	Failure Type
4-66-0-E/1-76-0-Q	N/A	0.00	1.00	0.0000	3	dur
1-76-0-Q/01-78-1-F	N/A	0.00	1.00	0.0000	23	dur

Path no. 56 Path Length 4

Compt ID	Cum L	Ign Mode	EB Time	Compt Fuel	Therm IAM	Dur IAM	FRI Time	CBO
4-66-0-E	0.8799	orig	0	0.5	N/A	N/A	3	20
1-76-0-Q	0.8931	dur	3	0.0	0.200	0.110	4	11
01-78-3-E	0.9504	therm	5	8.4	0.824	0.536	7	
01-68-1-L	0.9803	therm	22	70.9	0.603	0.344	27	

Connecting Barrier	HEI	Tbar	Dbar	IBV	Time Destroyed	Failure Type
4-66-0-E/1-76-0-Q	N/A	0.00	1.00	0.0000	3	dur
1-76-0-Q/01-78-3-E	N/A	0.00	1.00	0.0000	14	dur
01-78-3-E/01-68-1-L	51.1	1.00	0.00	0.0000		therm

 Path no. 57 Path Length 4

Compt ID	Cum L	Ign Mode	EB Time	Compt Fuel	Therm IAM	Dur IAM	FRI Time	CBO
4-66-0-E	0.8799	orig	0	0.5	N/A	N/A	3	20
1-76-0-Q	0.8931	dur	3	0.0	0.200	0.110	4	11
01-78-3-E	0.9504	therm	5	8.4	0.824	0.536	7	
01-78-1-F	0.9504	dur	5	73.9	0.000	0.000		5

Connecting Barrier	HEI	Tbar	Dbar	IBV	Time Destroyed	Failure Type
4-66-0-E/1-76-0-Q	N/A	0.00	1.00	0.0000	3	dur
1-76-0-Q/01-78-3-E	N/A	0.00	1.00	0.0000	14	dur
01-78-3-E/01-78-1-F	43.3	1.00	0.00	0.0000		therm

 Path no. 58 Path Length 4

Compt ID	Cum L	Ign Mode	EB Time	Compt Fuel	Therm IAM	Dur IAM	FRI Time	CBO
4-66-0-E	0.8799	orig	0	0.5	N/A	N/A	3	20
1-76-0-Q	0.8931	dur	3	0.0	0.200	0.110	4	11
01-78-3-E	0.9504	therm	5	8.4	0.824	0.536	7	
01-86-1-L	0.9866	therm	22	45.4	0.730	0.419		

Connecting Barrier	HEI	Tbar	Dbar	IBV	Time Destroyed	Failure Type
4-66-0-E/1-76-0-Q	N/A	0.00	1.00	0.0000	3	dur
1-76-0-Q/01-78-3-E	N/A	0.00	1.00	0.0000	14	dur
01-78-3-E/01-86-1-L	28.5	1.00	0.00	0.0000		therm

 Path no. 59 Path Length 3

Compt ID	Cum L	Ign Mode	EB Time	Compt Fuel	Therm IAM	Dur IAM	FRI Time	CBO
4-66-0-E	0.8799	orig	0	0.5	N/A	N/A	3	20
1-76-0-Q	0.8931	dur	3	0.0	0.200	0.110	4	11
01-79-0A-L	0.9861	dur	5	16.3	0.933	0.870	26	

Connecting Barrier	HEI	Tbar	Dbar	IBV	Time Destroyed	Failure Type
4-66-0-E/1-76-0-Q	N/A	0.00	1.00	0.0000	3	dur
1-76-0-Q/01-79-0A-L	N/A	0.00	1.00	0.0000	23	dur

 Path no. 60 Path Length 3

Compt ID	Cum L	Ign Mode	EB Time	Compt Fuel	Therm IAM	Dur IAM	FRI Time	CBO
4-66-0-E	0.8799	orig	0	0.5	N/A	N/A	3	20
1-76-0-Q	0.8931	dur	3	0.0	0.200	0.110	4	11
01-79-0B-L	0.9861	dur	5	27.5	0.933	0.870	22	

Connecting Barrier	HEI	Tbar	Dbar	IBV	Time	Failure
					Destroyed	Type
4-66-0-E/1-76-0-Q	N/A	0.00	1.00	0.0000	3	dur
1-76-0-Q/01-79-0B-L	N/A	0.00	1.00	0.0000	22	dur

Path no. 61 Path Length 3

Compt ID	Cum L	Ign Mode	EB Time	Compt Fuel	Therm IAM	Dur IAM	FRI Time	CBO
4-66-0-E	0.8799	orig	0	0.5	N/A	N/A	3	20
1-76-0-Q	0.8931	dur	3	0.0	0.200	0.110	4	11
02-85-0-Q	0.9537	therm	5	63.1	0.827	0.567	31	

Connecting Barrier	HEI	Tbar	Dbar	IBV	Time	Failure
					Destroyed	Type
4-66-0-E/1-76-0-Q	N/A	0.00	1.00	0.0000	3	dur
1-76-0-Q/02-85-0-Q	N/A	0.00	1.00	0.0000	23	dur

Path no. 62 Path Length 3

Compt ID	Cum L	Ign Mode	EB Time	Compt Fuel	Therm IAM	Dur IAM	FRI Time	CBO
4-66-0-E	0.8799	orig	0	0.5	N/A	N/A	3	20
1-76-0-Q	0.8931	dur	3	0.0	0.200	0.110	4	11
1-66-0-L	0.9325	dur	4	20.2	0.657	0.369	27	

Connecting Barrier	HEI	Tbar	Dbar	IBV	Time	Failure
					Destroyed	Type
4-66-0-E/1-76-0-Q	N/A	0.00	1.00	0.0000	3	dur
1-76-0-Q/1-66-0-L	N/A	0.00	1.00	0.0000	19	dur

Path no. 63 Path Length 4

Compt ID	Cum L	Ign Mode	EB Time	Compt Fuel	Therm IAM	Dur IAM	FRI Time	CBO
4-66-0-E	0.8799	orig	0	0.5	N/A	N/A	3	20
1-76-0-Q	0.8931	dur	3	0.0	0.200	0.110	4	11
1-66-0-L	0.9325	dur	4	20.2	0.657	0.369	27	
01-68-1-L	0.9829	therm	22	70.9	0.603	0.344	27	

Connecting Barrier	HEI	Tbar	Dbar	IBV	Time	Failure
					Destroyed	Type
4-66-0-E/1-76-0-Q	N/A	0.00	1.00	0.0000	3	dur
1-76-0-Q/1-66-0-L	N/A	0.00	1.00	0.0000	19	dur
1-66-0-L/01-68-1-L	7.0	0.64	0.00	0.0244		therm

Path no. 64 Path Length 4

Compt ID	Cum L	Ign Mode	EB Time	Compt Fuel	Therm IAM	Dur IAM	FRI Time	CBO
4-66-0-E	0.8799	orig	0	0.5	N/A	N/A	3	20

1-76-0-Q	0.8931	dur	3	0.0	0.200	0.110	4	11
1-66-0-L	0.9325	dur	4	20.2	0.657	0.369	27	
1-77-1-A	0.9821	therm	5	135.9	0.531	0.286	32	

Connecting Barrier	HEI	Tbar	Dbar	IBV	Time Destroyed	Failure Type
4-66-0-E/1-76-0-Q	N/A	0.00	1.00	0.0000	3	dur
1-76-0-Q/1-66-0-L	N/A	0.00	1.00	0.0000	19	dur
1-66-0-L/1-77-1-A	4.9	0.57	0.00	0.0293		therm

 Path no. 65 Path Length 4

Compt ID	Cum L	Ign Mode	EB Time	Compt Fuel	Therm IAM	Dur IAM	FRI Time	CBO
4-66-0-E	0.8799	orig	0	0.5	N/A	N/A	3	20
1-76-0-Q	0.8931	dur	3	0.0	0.200	0.110	4	11
1-66-0-L	0.9325	dur	4	20.2	0.657	0.369	27	
01-68-0-Q	0.9706	therm	5	94.2	0.565	0.303	10	

Connecting Barrier	HEI	Tbar	Dbar	IBV	Time Destroyed	Failure Type
4-66-0-E/1-76-0-Q	N/A	0.00	1.00	0.0000	3	dur
1-76-0-Q/1-66-0-L	N/A	0.00	1.00	0.0000	19	dur
1-66-0-L/01-68-0-Q	17.4	1.00	0.00	0.0000		therm

 Path no. 66 Path Length 4

Compt ID	Cum L	Ign Mode	EB Time	Compt Fuel	Therm IAM	Dur IAM	FRI Time	CBO
4-66-0-E	0.8799	orig	0	0.5	N/A	N/A	3	20
1-76-0-Q	0.8931	dur	3	0.0	0.200	0.110	4	11
1-66-0-L	0.9325	dur	4	20.2	0.657	0.369	27	
1-66-1-Q	0.9714	dur	6	4.2	0.866	0.576	31	

Connecting Barrier	HEI	Tbar	Dbar	IBV	Time Destroyed	Failure Type
4-66-0-E/1-76-0-Q	N/A	0.00	1.00	0.0000	3	dur
1-76-0-Q/1-66-0-L	N/A	0.00	1.00	0.0000	19	dur
1-66-0-L/1-66-1-Q	0.1	0.00	1.00	0.0000	27	dur

 Path no. 67 Path Length 5

Compt ID	Cum L	Ign Mode	EB Time	Compt Fuel	Therm IAM	Dur IAM	FRI Time	CBO
4-66-0-E	0.8799	orig	0	0.5	N/A	N/A	3	20
1-76-0-Q	0.8931	dur	3	0.0	0.200	0.110	4	11
1-66-0-L	0.9325	dur	4	20.2	0.657	0.369	27	
1-66-1-Q	0.9714	dur	6	4.2	0.866	0.576	31	
1-66-0-L	0.9819	dur	4	20.2	0.657	0.369	27	

Connecting Barrier	HEI	Tbar	Dbar	IBV	Time Destroyed	Failure Type

4-66-0-E/1-76-0-Q	N/A	0.00	1.00	0.0000	3	dur
1-76-0-Q/1-66-0-L	N/A	0.00	1.00	0.0000	19	dur
1-66-0-L/1-66-1-Q	0.1	0.00	1.00	0.0000	27	dur
1-66-1-Q/1-66-0-L	0.1	0.00	1.00	0.0000	27	dur

 Path no. 68 Path Length 5

Compt ID	Cum L	Ign Mode	EB Time	Compt Fuel	Therm IAM	Dur IAM	FRI Time	CBO
4-66-0-E	0.8799	orig	0	0.5	N/A	N/A	3	20
1-76-0-Q	0.8931	dur	3	0.0	0.200	0.110	4	11
1-66-0-L	0.9325	dur	4	20.2	0.657	0.369	27	
1-66-1-Q	0.9714	dur	6	4.2	0.866	0.576	31	
01-68-0-Q	0.9876	therm	5	94.2	0.565	0.303	10	

Connecting Barrier	HEI	Tbar	Dbar	IBV	Time Destroyed	Failure Type
4-66-0-E/1-76-0-Q	N/A	0.00	1.00	0.0000	3	dur
1-76-0-Q/1-66-0-L	N/A	0.00	1.00	0.0000	19	dur
1-66-0-L/1-66-1-Q	0.1	0.00	1.00	0.0000	27	dur
1-66-1-Q/01-68-0-Q	14.5	1.00	0.00	0.0000		therm

 Path no. 69 Path Length 3

Compt ID	Cum L	Ign Mode	EB Time	Compt Fuel	Therm IAM	Dur IAM	FRI Time	CBO
4-66-0-E	0.8799	orig	0	0.5	N/A	N/A	3	20
1-76-0-Q	0.8931	dur	3	0.0	0.200	0.110	4	11
4-82-0-E	0.9864	therm	4	0.0	0.873	0.620	7	52

Connecting Barrier	HEI	Tbar	Dbar	IBV	Time Destroyed	Failure Type
4-66-0-E/1-76-0-Q	N/A	0.00	1.00	0.0000	3	dur
1-76-0-Q/4-82-0-E	N/A	1.00	0.00	0.0000	13	dur

 Path no. 70 Path Length 4

Compt ID	Cum L	Ign Mode	EB Time	Compt Fuel	Therm IAM	Dur IAM	FRI Time	CBO
4-66-0-E	0.8799	orig	0	0.5	N/A	N/A	3	20
1-76-0-Q	0.8931	dur	3	0.0	0.200	0.110	4	11
4-82-0-E	0.9864	therm	4	0.0	0.873	0.620	7	52
1-76-0-Q	0.9879	dur	3	0.0	0.200	0.110	4	11

Connecting Barrier	HEI	Tbar	Dbar	IBV	Time Destroyed	Failure Type
4-66-0-E/1-76-0-Q	N/A	0.00	1.00	0.0000	3	dur
1-76-0-Q/4-82-0-E	N/A	1.00	0.00	0.0000	13	dur
4-82-0-E/1-76-0-Q	N/A	0.00	1.00	0.0000	13	dur

 Path no. 71 Path Length 3

Compt	Ign	EB	Compt	Therm	Dur	FRI	CBO
-------	-----	----	-------	-------	-----	-----	-----

ID	Cum L	Mode	Time	Fuel	IAM	IAM	Time	
4-66-0-E	0.8799	orig	0	0.5	N/A	N/A	3	20
1-76-0-Q	0.8931	dur	3	0.0	0.200	0.110	4	11
01-60-0A-L	0.9861	dur	4	29.9	0.933	0.870	27	

Connecting Barrier	HEI	Tbar	Dbar	IBV	Time Destroyed	Failure Type
4-66-0-E/1-76-0-Q	N/A	0.00	1.00	0.0000	3	dur
1-76-0-Q/01-60-0A-L	N/A	0.00	1.00	0.0000	19	dur

 Path no. 72 Path Length 3

Compt ID	Cum L	Ign Mode	EB Time	Compt Fuel	Therm IAM	Dur IAM	FRI Time	CBO
4-66-0-E	0.8799	orig	0	0.5	N/A	N/A	3	20
1-76-0-Q	0.8931	dur	3	0.0	0.200	0.110	4	11
01-74-1-L	0.9789	dur	4	34.3	0.947	0.803	27	

Connecting Barrier	HEI	Tbar	Dbar	IBV	Time Destroyed	Failure Type
4-66-0-E/1-76-0-Q	N/A	0.00	1.00	0.0000	3	dur
1-76-0-Q/01-74-1-L	N/A	0.00	1.00	0.0000	19	dur

 Path no. 73 Path Length 4

Compt ID	Cum L	Ign Mode	EB Time	Compt Fuel	Therm IAM	Dur IAM	FRI Time	CBO
4-66-0-E	0.8799	orig	0	0.5	N/A	N/A	3	20
1-76-0-Q	0.8931	dur	3	0.0	0.200	0.110	4	11
02-73-0-Q	0.9615	therm	4	38.7	1.000	0.640	6	
03-76-0-Q	0.9720	therm	4	6.1	0.272	0.146	6	

Connecting Barrier	HEI	Tbar	Dbar	IBV	Time Destroyed	Failure Type
4-66-0-E/1-76-0-Q	N/A	0.00	1.00	0.0000	3	dur
1-76-0-Q/02-73-0-Q	N/A	0.00	1.00	0.0000	14	dur
02-73-0-Q/03-76-0-Q	40.2	1.00	0.00	0.0000		therm

 Path no. 74 Path Length 3

Compt ID	Cum L	Ign Mode	EB Time	Compt Fuel	Therm IAM	Dur IAM	FRI Time	CBO
4-66-0-E	0.8799	orig	0	0.5	N/A	N/A	3	20
1-76-0-Q	0.8931	dur	3	0.0	0.200	0.110	4	11
03-76-0-Q	0.9087	therm	4	6.1	0.272	0.146	6	

Connecting Barrier	HEI	Tbar	Dbar	IBV	Time Destroyed	Failure Type
4-66-0-E/1-76-0-Q	N/A	0.00	1.00	0.0000	3	dur
1-76-0-Q/03-76-0-Q	N/A	0.00	1.00	0.0000	18	dur

 Path no. 75 Path Length 4

Compt ID	Cum L	Ign Mode	EB Time	Compt Fuel	Therm IAM	Dur IAM	FRI Time	CBO
4-66-0-E	0.8799	orig	0	0.5	N/A	N/A	3	20
1-76-0-Q	0.8931	dur	3	0.0	0.200	0.110	4	11
1-80-1-Q	0.9641	dur	4	42.0	1.000	0.664	27	
03-76-0-Q	0.9739	therm	4	6.1	0.272	0.146	6	

Connecting Barrier	HEI	Tbar	Dbar	IBV	Time Destroyed	Failure Type
4-66-0-E/1-76-0-Q	N/A	0.00	1.00	0.0000	3	dur
1-76-0-Q/1-80-1-Q	N/A	0.00	1.00	0.0000	19	dur
1-80-1-Q/03-76-0-Q	32.7	1.00	0.00	0.0000		therm

 Path no. 76 Path Length 3

Compt ID	Cum L	Ign Mode	EB Time	Compt Fuel	Therm IAM	Dur IAM	FRI Time	CBO
4-66-0-E	0.8799	orig	0	0.5	N/A	N/A	3	20
2-89-1-C	0.9273	dur	3	0.0	0.655	0.394	4	31
1-66-0-L	0.9645	dur	4	20.2	0.657	0.369	27	

Connecting Barrier	HEI	Tbar	Dbar	IBV	Time Destroyed	Failure Type
4-66-0-E/2-89-1-C	N/A	0.00	1.00	0.0000	14	dur
2-89-1-C/1-66-0-L	110.4	0.50	0.50	0.0000	49	dur

 Path no. 77 Path Length 4

Compt ID	Cum L	Ign Mode	EB Time	Compt Fuel	Therm IAM	Dur IAM	FRI Time	CBO
4-66-0-E	0.8799	orig	0	0.5	N/A	N/A	3	20
2-89-1-C	0.9273	dur	3	0.0	0.655	0.394	4	31
1-66-0-L	0.9645	dur	4	20.2	0.657	0.369	27	
01-68-0-Q	0.9845	therm	5	94.2	0.565	0.303	10	

Connecting Barrier	HEI	Tbar	Dbar	IBV	Time Destroyed	Failure Type
4-66-0-E/2-89-1-C	N/A	0.00	1.00	0.0000	14	dur
2-89-1-C/1-66-0-L	110.4	0.50	0.50	0.0000	49	dur
1-66-0-L/01-68-0-Q	17.4	1.00	0.00	0.0000		therm

 Path no. 78 Path Length 4

Compt ID	Cum L	Ign Mode	EB Time	Compt Fuel	Therm IAM	Dur IAM	FRI Time	CBO
4-66-0-E	0.8799	orig	0	0.5	N/A	N/A	3	20
2-89-1-C	0.9273	dur	3	0.0	0.655	0.394	4	31
1-66-0-L	0.9645	dur	4	20.2	0.657	0.369	27	
1-66-1-Q	0.9849	dur	6	4.2	0.866	0.576	31	

Connecting Barrier	HEI	Tbar	Dbar	IBV	Time	Failure
					Destroyed	Type
4-66-0-E/2-89-1-C	N/A	0.00	1.00	0.0000	14	dur
2-89-1-C/1-66-0-L	110.4	0.50	0.50	0.0000	49	dur
1-66-0-L/1-66-1-Q	0.1	0.00	1.00	0.0000	27	dur

 Path no. 79 Path Length 3

Compt ID	Cum L	Ign Mode	EB Time	Compt Fuel	Therm IAM	Dur IAM	FRI Time	CBO
4-66-0-E	0.8799	orig	0	0.5	N/A	N/A	3	20
2-89-1-C	0.9273	dur	3	0.0	0.655	0.394	4	31
1-66-3-Q	0.9879	dur	6	30.4	0.924	0.661	57	

Connecting Barrier	HEI	Tbar	Dbar	IBV	Time	Failure
					Destroyed	Type
4-66-0-E/2-89-1-C	N/A	0.00	1.00	0.0000	14	dur
2-89-1-C/1-66-3-Q	100.9	0.65	0.35	0.0000	52	therm

 Path no. 80 Path Length 4

Compt ID	Cum L	Ign Mode	EB Time	Compt Fuel	Therm IAM	Dur IAM	FRI Time	CBO
4-66-0-E	0.8799	orig	0	0.5	N/A	N/A	3	20
2-89-1-C	0.9273	dur	3	0.0	0.655	0.394	4	31
1-77-3-L	0.9628	therm	6	57.2	0.657	0.369	27	
1-77-1-A	0.9892	therm	5	135.9	0.531	0.286	32	

Connecting Barrier	HEI	Tbar	Dbar	IBV	Time	Failure
					Destroyed	Type
4-66-0-E/2-89-1-C	N/A	0.00	1.00	0.0000	14	dur
2-89-1-C/1-77-3-L	113.6	0.42	0.58	0.0000	48	dur
1-77-3-L/1-77-1-A	7.9	0.62	0.00	0.0142		therm

 Path no. 81 Path Length 4

Compt ID	Cum L	Ign Mode	EB Time	Compt Fuel	Therm IAM	Dur IAM	FRI Time	CBO
4-66-0-E	0.8799	orig	0	0.5	N/A	N/A	3	20
2-89-1-C	0.9273	dur	3	0.0	0.655	0.394	4	31
1-77-3-L	0.9628	therm	6	57.2	0.657	0.369	27	
01-68-1-L	0.9887	therm	22	70.9	0.603	0.344	27	

Connecting Barrier	HEI	Tbar	Dbar	IBV	Time	Failure
					Destroyed	Type
4-66-0-E/2-89-1-C	N/A	0.00	1.00	0.0000	14	dur
2-89-1-C/1-77-3-L	113.6	0.42	0.58	0.0000	48	dur
1-77-3-L/01-68-1-L	8.8	0.77	0.00	0.0087		therm

PATH OPTION - DETAIL LEVEL REPORT

INFORMATION ON ALL PATHS FROM 4-82-0-E

READINESS CONDITION . YOKE
 CONFIGURATION Passive, Automatic, and Manual
 CASE Worst
 ASSUMED LOCATION at SEA
 RUN TIME 60 minutes
 COMMENTS
 Ship Visit Baseline
 At Sea

 Path no. 1 Path Length 2

Compt ID	Cum L	Ign Mode	EB Time	Compt Fuel	Therm IAM	Dur IAM	FRI Time	CBO
4-82-0-E	0.8710	orig	0	5.4	N/A	N/A	3	
1-82-2-Q	0.9395	therm	15	5.2	0.531	0.286		

Connecting Barrier	HEI	Tbar	Dbar	IBV	Time Destroyed	Failure Type
4-82-0-E/1-82-2-Q	N/A	1.00	0.00	0.0000		therm

 Path no. 2 Path Length 2

Compt ID	Cum L	Ign Mode	EB Time	Compt Fuel	Therm IAM	Dur IAM	FRI Time	CBO
4-82-0-E	0.8710	orig	0	5.4	N/A	N/A	3	
1-85-3-L	0.9746	therm	15	59.2	0.803	0.500	48	

Connecting Barrier	HEI	Tbar	Dbar	IBV	Time Destroyed	Failure Type
4-82-0-E/1-85-3-L	N/A	1.00	0.00	0.0000		therm

 Path no. 3 Path Length 2

Compt ID	Cum L	Ign Mode	EB Time	Compt Fuel	Therm IAM	Dur IAM	FRI Time	CBO
4-82-0-E	0.8710	orig	0	5.4	N/A	N/A	3	
1-85-4-L	0.9746	therm	15	53.5	0.803	0.500		

Connecting Barrier	HEI	Tbar	Dbar	IBV	Time Destroyed	Failure Type
4-82-0-E/1-85-4-L	N/A	1.00	0.00	0.0000		therm

 Path no. 4 Path Length 2

Compt ID	Cum L	Ign Mode	EB Time	Compt Fuel	Therm IAM	Dur IAM	FRI Time	CBO
4-82-0-E	0.8710	orig	0	5.4	N/A	N/A	3	
4-92-0-E	0.9864	therm	15	3.7	0.894	0.590	17	

Connecting Barrier	HEI	Tbar	Dbar	IBV	Time Destroyed	Failure Type
4-82-0-E/4-92-0-E	N/A	1.00	0.00	0.0000		therm

 Path no. 5 Path Length 2

Compt ID	Cum L	Ign Mode	EB Time	Compt Fuel	Therm IAM	Dur IAM	FRI Time	CBO
4-82-0-E	0.8710	orig	0	5.4	N/A	N/A	3	
1-85-1-L	0.9746	dur	6	50.0	0.803	0.500	17	

Connecting Barrier	HEI	Tbar	Dbar	IBV	Time Destroyed	Failure Type
4-82-0-E/1-85-1-L	N/A	1.00	0.00	0.0000		therm

 Path no. 6 Path Length 3

Compt ID	Cum L	Ign Mode	EB Time	Compt Fuel	Therm IAM	Dur IAM	FRI Time	CBO
4-82-0-E	0.8710	orig	0	5.4	N/A	N/A	3	
2-89-1-C	0.9228	dur	8	38.3	0.655	0.394	9	
1-66-0-L	0.9735	dur	7	20.4	0.657	0.369	30	

Connecting Barrier	HEI	Tbar	Dbar	IBV	Time Destroyed	Failure Type
4-82-0-E/2-89-1-C	N/A	0.03	0.97	0.0000	42	dur
2-89-1-C/1-66-0-L	34.1	1.00	0.00	0.0000		therm

 Path no. 7 Path Length 4

Compt ID	Cum L	Ign Mode	EB Time	Compt Fuel	Therm IAM	Dur IAM	FRI Time	CBO
4-82-0-E	0.8710	orig	0	5.4	N/A	N/A	3	
2-89-1-C	0.9228	dur	8	38.3	0.655	0.394	9	
1-66-0-L	0.9735	dur	7	20.4	0.657	0.369	30	
01-68-0-Q	0.9885	therm	8	94.7	0.565	0.303	13	

Connecting Barrier	HEI	Tbar	Dbar	IBV	Time Destroyed	Failure Type
4-82-0-E/2-89-1-C	N/A	0.03	0.97	0.0000	42	dur
2-89-1-C/1-66-0-L	34.1	1.00	0.00	0.0000		therm
1-66-0-L/01-68-0-Q	16.1	1.00	0.00	0.0000		therm

 Path no. 8 Path Length 4

Compt ID	Cum L	Ign Mode	EB Time	Compt Fuel	Therm IAM	Dur IAM	FRI Time	CBO
4-82-0-E	0.8710	orig	0	5.4	N/A	N/A	3	
2-89-1-C	0.9228	dur	8	38.3	0.655	0.394	9	
1-66-0-L	0.9735	dur	7	20.4	0.657	0.369	30	
1-66-1-Q	0.9888	dur	12	4.2	0.866	0.576	34	

Connecting Barrier	HEI	Tbar	Dbar	IBV	Time Destroyed	Failure Type
4-82-0-E/2-89-1-C	N/A	0.03	0.97	0.0000	42	dur
2-89-1-C/1-66-0-L	34.1	1.00	0.00	0.0000		therm
1-66-0-L/1-66-1-Q	0.1	0.00	1.00	0.0000	30	dur

Path no. 9 Path Length 3

Compt ID	Cum L	Ign Mode	EB Time	Compt Fuel	Therm IAM	Dur IAM	FRI Time	CBO
4-82-0-E	0.8710	orig	0	5.4	N/A	N/A	3	
2-89-1-C	0.9228	dur	8	38.3	0.655	0.394	9	
1-77-3-L	0.9735	therm	12	57.9	0.657	0.369	33	

Connecting Barrier	HEI	Tbar	Dbar	IBV	Time Destroyed	Failure Type
4-82-0-E/2-89-1-C	N/A	0.03	0.97	0.0000	42	dur
2-89-1-C/1-77-3-L	36.1	1.00	0.00	0.0000		therm

Path no. 10 Path Length 3

Compt ID	Cum L	Ign Mode	EB Time	Compt Fuel	Therm IAM	Dur IAM	FRI Time	CBO
4-82-0-E	0.8710	orig	0	5.4	N/A	N/A	3	
4-66-0-E	0.9470	dur	7	0.0	0.897	0.589	8	31
3-57-0-A	0.9706	therm	12	68.1	0.745	0.446	17	

Connecting Barrier	HEI	Tbar	Dbar	IBV	Time Destroyed	Failure Type
4-82-0-E/4-66-0-E	N/A	0.00	1.00	0.0000	25	dur
4-66-0-E/3-57-0-A	N/A	0.00	1.00	0.0000	35	dur

Path no. 11 Path Length 3

Compt ID	Cum L	Ign Mode	EB Time	Compt Fuel	Therm IAM	Dur IAM	FRI Time	CBO
4-82-0-E	0.8710	orig	0	5.4	N/A	N/A	3	
4-66-0-E	0.9470	dur	7	0.0	0.897	0.589	8	31
2-57-1-Q	0.9669	therm	12	54.8	0.646	0.376	18	

Connecting Barrier	HEI	Tbar	Dbar	IBV	Time Destroyed	Failure Type
4-82-0-E/4-66-0-E	N/A	0.00	1.00	0.0000	25	dur
4-66-0-E/2-57-1-Q	N/A	0.00	1.00	0.0000	38	dur

 Path no. 12 Path Length 4

Compt ID	Cum L	Ign Mode	EB Time	Compt Fuel	Therm IAM	Dur IAM	FRI Time	CBO
4-82-0-E	0.8710	orig	0	5.4	N/A	N/A	3	
4-66-0-E	0.9470	dur	7	0.0	0.897	0.589	8	31
2-57-4-E	0.9686	therm	12	40.4	0.570	0.409	14	
2-57-2-A	0.9826	therm	52	0.0	0.745	0.446	56	60

Connecting Barrier	HEI	Tbar	Dbar	IBV	Time Destroyed	Failure Type
4-82-0-E/4-66-0-E	N/A	0.00	1.00	0.0000	25	dur
4-66-0-E/2-57-4-E	N/A	0.00	1.00	0.0000	35	dur
2-57-4-E/2-57-2-A	N/A	0.00	1.00	0.0000	59	dur

 Path no. 13 Path Length 4

Compt ID	Cum L	Ign Mode	EB Time	Compt Fuel	Therm IAM	Dur IAM	FRI Time	CBO
4-82-0-E	0.8710	orig	0	5.4	N/A	N/A	3	
4-66-0-E	0.9470	dur	7	0.0	0.897	0.589	8	31
2-57-4-E	0.9686	therm	12	40.4	0.570	0.409	14	
1-60-6B-A	0.9826	dur	16	0.0	0.745	0.446	17	20

Connecting Barrier	HEI	Tbar	Dbar	IBV	Time Destroyed	Failure Type
4-82-0-E/4-66-0-E	N/A	0.00	1.00	0.0000	25	dur
4-66-0-E/2-57-4-E	N/A	0.00	1.00	0.0000	35	dur
2-57-4-E/1-60-6B-A	N/A	0.00	1.00	0.0000	24	dur

 Path no. 14 Path Length 5

Compt ID	Cum L	Ign Mode	EB Time	Compt Fuel	Therm IAM	Dur IAM	FRI Time	CBO
4-82-0-E	0.8710	orig	0	5.4	N/A	N/A	3	
4-66-0-E	0.9470	dur	7	0.0	0.897	0.589	8	31
2-57-4-E	0.9686	therm	12	40.4	0.570	0.409	14	
1-60-6B-A	0.9826	dur	16	0.0	0.745	0.446	17	20
01-83-2-L	0.9899	dur	18	45.1	0.730	0.419	36	

Connecting Barrier	HEI	Tbar	Dbar	IBV	Time Destroyed	Failure Type
4-82-0-E/4-66-0-E	N/A	0.00	1.00	0.0000	25	dur
4-66-0-E/2-57-4-E	N/A	0.00	1.00	0.0000	35	dur
2-57-4-E/1-60-6B-A	N/A	0.00	1.00	0.0000	24	dur
1-60-6B-A/01-83-2-L	N/A	0.00	1.00	0.0000	29	dur

 Path no. 15 Path Length 3

Compt ID	Cum L	Ign Mode	EB Time	Compt Fuel	Therm IAM	Dur IAM	FRI Time	CBO
----------	-------	----------	---------	------------	-----------	---------	----------	-----

4-82-0-E	0.8710	orig	0	5.4	N/A	N/A	3	
4-66-0-E	0.9470	dur	7	0.0	0.897	0.589	8	31
2-59-1-Q	0.9669	therm	12	54.6	0.646	0.376	17	

Connecting Barrier	HEI	Tbar	Dbar	IBV	Time Destroyed	Failure Type
4-82-0-E/4-66-0-E	N/A	0.00	1.00	0.0000	25	dur
4-66-0-E/2-59-1-Q	N/A	0.00	1.00	0.0000	37	dur

 Path no. 16 Path Length 3

Compt ID	Cum L	Ign Mode	EB Time	Compt Fuel	Therm IAM	Dur IAM	FRI Time	CBO
4-82-0-E	0.8710	orig	0	5.4	N/A	N/A	3	
4-66-0-E	0.9470	dur	7	0.0	0.897	0.589	8	31
1-60-6A-A	0.9706	therm	12	6.2	0.745	0.446	16	18

Connecting Barrier	HEI	Tbar	Dbar	IBV	Time Destroyed	Failure Type
4-82-0-E/4-66-0-E	N/A	0.00	1.00	0.0000	25	dur
4-66-0-E/1-60-6A-A	N/A	0.00	1.00	0.0000	21	dur

 Path no. 17 Path Length 4

-Compt ID	Cum L	Ign Mode	EB Time	Compt Fuel	Therm IAM	Dur IAM	FRI Time	CBO
4-82-0-E	0.8710	orig	0	5.4	N/A	N/A	3	
4-66-0-E	0.9470	dur	7	0.0	0.897	0.589	8	31
1-60-6A-A	0.9706	therm	12	6.2	0.745	0.446	16	18
01-70-2-Q	0.9790	dur	17	15.4	0.531	0.286	35	

Connecting Barrier	HEI	Tbar	Dbar	IBV	Time Destroyed	Failure Type
4-82-0-E/4-66-0-E	N/A	0.00	1.00	0.0000	25	dur
4-66-0-E/1-60-6A-A	N/A	0.00	1.00	0.0000	21	dur
1-60-6A-A/01-70-2-Q	N/A	0.00	1.00	0.0000	28	dur

 Path no. 18 Path Length 4

Compt ID	Cum L	Ign Mode	EB Time	Compt Fuel	Therm IAM	Dur IAM	FRI Time	CBO
4-82-0-E	0.8710	orig	0	5.4	N/A	N/A	3	
4-66-0-E	0.9470	dur	7	0.0	0.897	0.589	8	31
1-60-6A-A	0.9706	therm	12	6.2	0.745	0.446	16	18
1-60-6B-A	0.9837	dur	16	0.0	0.745	0.446	17	20

Connecting Barrier	HEI	Tbar	Dbar	IBV	Time Destroyed	Failure Type
4-82-0-E/4-66-0-E	N/A	0.00	1.00	0.0000	25	dur
4-66-0-E/1-60-6A-A	N/A	0.00	1.00	0.0000	21	dur
1-60-6A-A/1-60-6B-A	N/A	0.00	1.00	0.0000	16	dur

.....
 Path no. 19 Path Length 4

Compt ID	Cum L	Ign Mode	EB Time	Compt Fuel	Therm IAM	Dur IAM	FRI Time	CBO
4-82-0-E	0.8710	orig	0	5.4	N/A	N/A	3	
4-66-0-E	0.9470	dur	7	0.0	0.897	0.589	8	31
1-60-6A-A	0.9706	therm	12	6.2	0.745	0.446	16	18
1-71-2-Q	0.9795	therm	12	34.2	0.565	0.303	17	

Connecting Barrier	HEI	Tbar	Dbar	IBV	Time Destroyed	Failure Type
4-82-0-E/4-66-0-E	N/A	0.00	1.00	0.0000	25	dur
4-66-0-E/1-60-6A-A	N/A	0.00	1.00	0.0000	21	dur
1-60-6A-A/1-71-2-Q	N/A	0.00	1.00	0.0000	21	dur

.....
 Path no. 20 Path Length 3

Compt ID	Cum L	Ign Mode	EB Time	Compt Fuel	Therm IAM	Dur IAM	FRI Time	CBO
4-82-0-E	0.8710	orig	0	5.4	N/A	N/A	3	
4-66-0-E	0.9470	dur	7	0.0	0.897	0.589	8	31
1-66-0-L	0.9771	dur	7	20.4	0.657	0.369	30	

Connecting Barrier	HEI	Tbar	Dbar	IBV	Time Destroyed	Failure Type
4-82-0-E/4-66-0-E	N/A	0.00	1.00	0.0000	25	dur
4-66-0-E/1-66-0-L	N/A	0.69	0.31	0.0000	54	therm

.....
 Path no. 21 Path Length 3

Compt ID	Cum L	Ign Mode	EB Time	Compt Fuel	Therm IAM	Dur IAM	FRI Time	CBO
4-82-0-E	0.8710	orig	0	5.4	N/A	N/A	3	
4-66-0-E	0.9470	dur	7	0.0	0.897	0.589	8	31
1-66-1-Q	0.9893	dur	12	4.2	0.866	0.576	34	

Connecting Barrier	HEI	Tbar	Dbar	IBV	Time Destroyed	Failure Type
4-82-0-E/4-66-0-E	N/A	0.00	1.00	0.0000	25	dur
4-66-0-E/1-66-1-Q	N/A	0.77	0.23	0.0000	56	therm

.....
 Path no. 22 Path Length 3

Compt ID	Cum L	Ign Mode	EB Time	Compt Fuel	Therm IAM	Dur IAM	FRI Time	CBO
4-82-0-E	0.8710	orig	0	5.4	N/A	N/A	3	
4-66-0-E	0.9470	dur	7	0.0	0.897	0.589	8	31
1-71-2-Q	0.9710	therm	12	34.2	0.565	0.303	17	

Connecting Barrier	HEI	Tbar	Dbar	IBV	Time Destroyed	Failure Type

4-82-0-E/4-66-0-E	N/A	0.00	1.00	0.0000	25	dur
4-66-0-E/1-71-2-Q	N/A	0.57	0.43	-0.0000	51	therm

 Path no. 23 Path Length 3

Compt ID	Cum L	Ign Mode	EB Time	Compt Fuel	Therm IAM	Dur IAM	FRI Time	CBO
4-82-0-E	0.8710	orig	0	5.4	N/A	N/A	3	
4-66-0-E	0.9470	dur	7	0.0	0.897	0.589	8	31
1-74-2-Q	0.9816	therm	12	28.6	0.680	0.506		

Connecting Barrier	HEI	Tbar	Dbar	IBV	Time Destroyed	Failure Type
4-82-0-E/4-66-0-E	N/A	0.00	1.00	0.0000	25	dur
4-66-0-E/1-74-2-Q	N/A	0.85	0.15	0.0000	59	therm

 Path no. 24 Path Length 3

Compt ID	Cum L	Ign Mode	EB Time	Compt Fuel	Therm IAM	Dur IAM	FRI Time	CBO
4-82-0-E	0.8710	orig	0	5.4	N/A	N/A	3	
4-66-0-E	0.9470	dur	7	0.0	0.897	0.589	8	31
1-77-1-A	0.9721	therm	8	135.9	0.531	0.286	35	

Connecting Barrier	HEI	Tbar	Dbar	IBV	Time Destroyed	Failure Type
4-82-0-E/4-66-0-E	N/A	0.00	1.00	0.0000	25	dur
4-66-0-E/1-77-1-A	N/A	0.76	0.24	-0.0000	56	therm

 Path no. 25 Path Length 3

Compt ID	Cum L	Ign Mode	EB Time	Compt Fuel	Therm IAM	Dur IAM	FRI Time	CBO
4-82-0-E	0.8710	orig	0	5.4	N/A	N/A	3	
4-66-0-E	0.9470	dur	7	0.0	0.897	0.589	8	31
1-77-2-L	0.9794	therm	12	51.2	0.657	0.369		

Connecting Barrier	HEI	Tbar	Dbar	IBV	Time Destroyed	Failure Type
4-82-0-E/4-66-0-E	N/A	0.00	1.00	0.0000	25	dur
4-66-0-E/1-77-2-L	N/A	0.85	0.15	0.0000	59	therm

 Path no. 26 Path Length 3

Compt ID	Cum L	Ign Mode	EB Time	Compt Fuel	Therm IAM	Dur IAM	FRI Time	CBO
4-82-0-E	0.8710	orig	0	5.4	N/A	N/A	3	
4-66-0-E	0.9470	dur	7	0.0	0.897	0.589	8	31
1-77-3-L	0.9767	therm	12	57.9	0.657	0.369	33	

Connecting Barrier	HEI	Tbar	Dbar	IBV	Time Destroyed	Failure Type
4-82-0-E/4-66-0-E	N/A	0.00	1.00	0.0000	25	dur
4-66-0-E/1-77-3-L	N/A	0.67	0.33	0.0000	54	therm

 Path no. 27 Path Length 4

Compt ID	Cum L	Ign Mode	EB Time	Compt Fuel	Therm IAM	Dur IAM	FRI Time	CBO
4-82-0-E	0.8710	orig	0	5.4	N/A	N/A	3	
1-76-0-Q	0.8852	therm	5	0.0	0.200	0.110	7	11
1-77-1-A	0.9180	therm	8	135.9	0.531	0.286	35	
1-77-3-L	0.9847	therm	12	57.9	0.657	0.369	33	

Connecting Barrier	HEI	Tbar	Dbar	IBV	Time Destroyed	Failure Type
4-82-0-E/1-76-0-Q	N/A	0.00	1.00	0.0000	15	dur
1-76-0-Q/1-77-1-A	N/A	0.00	1.00	0.0000	26	dur
1-77-1-A/1-77-3-L	6.8	0.54	0.00	0.0375		therm

 Path no. 28 Path Length 3

Compt ID	Cum L	Ign Mode	EB Time	Compt Fuel	Therm IAM	Dur IAM	FRI Time	CBO
4-82-0-E	0.8710	orig	0	5.4	N/A	N/A	3	
1-76-0-Q	0.8852	therm	5	0.0	0.200	0.110	7	11
1-80-1-E	0.9614	dur	8	35.5	1.000	0.664	36	

Connecting Barrier	HEI	Tbar	Dbar	IBV	Time Destroyed	Failure Type
4-82-0-E/1-76-0-Q	N/A	0.00	1.00	0.0000	15	dur
1-76-0-Q/1-80-1-E	N/A	0.00	1.00	0.0000	26	dur

 Path no. 29 Path Length 4

Compt ID	Cum L	Ign Mode	EB Time	Compt Fuel	Therm IAM	Dur IAM	FRI Time	CBO
4-82-0-E	0.8710	orig	0	5.4	N/A	N/A	3	
1-76-0-Q	0.8852	therm	5	0.0	0.200	0.110	7	11
01-68-0-Q	0.9200	therm	8	94.7	0.565	0.303	13	
01-68-1-L	0.9682	therm	25	71.1	0.603	0.344	30	

Connecting Barrier	HEI	Tbar	Dbar	IBV	Time Destroyed	Failure Type
4-82-0-E/1-76-0-Q	N/A	0.00	1.00	0.0000	15	dur
1-76-0-Q/01-68-0-Q	N/A	0.00	1.00	0.0000	19	dur
01-68-0-Q/01-68-1-L	N/A	1.00	0.00	0.0000		therm

 Path no. 30 Path Length 4

Compt ID	Cum L	Ign Mode	EB Time	Compt Fuel	Therm IAM	Dur IAM	FRI Time	CBO
----------	-------	----------	---------	------------	-----------	---------	----------	-----

Compt ID	Cum L	Ign Mode	EB Time	Compt Fuel	Therm IAM	Dur IAM	FRI Time	CBO
4-82-0-E	0.8710	orig	0	5.4	N/A	N/A	3	
1-76-0-Q	0.8852	therm	5	0.0	0.200	0.110	7	11
01-68-0-Q	0.9200	therm	8	94.7	0.565	0.303	13	
02-66-0-C	0.9658	therm	27	76.9	0.572	0.344	32	

Connecting Barrier	HEI	Tbar	Dbar	IBV	Time Destroyed	Failure Type
4-82-0-E/1-76-0-Q	N/A	0.00	1.00	0.0000	15	dur
1-76-0-Q/01-68-0-Q	N/A	0.00	1.00	0.0000	19	dur
01-68-0-Q/02-66-0-C	N/A	1.00	0.00	0.0000		therm

 Path no. 31 Path Length 5

Compt ID	Cum L	Ign Mode	EB Time	Compt Fuel	Therm IAM	Dur IAM	FRI Time	CBO
4-82-0-E	0.8710	orig	0	5.4	N/A	N/A	3	
1-76-0-Q	0.8852	therm	5	0.0	0.200	0.110	7	11
01-68-0-Q	0.9200	therm	8	94.7	0.565	0.303	13	
02-66-0-C	0.9658	therm	27	76.9	0.572	0.344	32	
03-56-0B-C	0.9803	dur	43	0.0	0.690	0.418	44	59

Connecting Barrier	HEI	Tbar	Dbar	IBV	Time Destroyed	Failure Type
4-82-0-E/1-76-0-Q	N/A	0.00	1.00	0.0000	15	dur
1-76-0-Q/01-68-0-Q	N/A	0.00	1.00	0.0000	19	dur
01-68-0-Q/02-66-0-C	N/A	1.00	0.00	0.0000		therm
02-66-0-C/03-56-0B-C	112.2	0.03	0.97	0.0000	55	dur

 Path no. 32 Path Length 3

Compt ID	Cum L	Ign Mode	EB Time	Compt Fuel	Therm IAM	Dur IAM	FRI Time	CBO
4-82-0-E	0.8710	orig	0	5.4	N/A	N/A	3	
1-76-0-Q	0.8852	therm	5	0.0	0.200	0.110	7	11
01-78-1-F	0.8852	dur	8	68.1	0.000	0.000		8

Connecting Barrier	HEI	Tbar	Dbar	IBV	Time Destroyed	Failure Type
4-82-0-E/1-76-0-Q	N/A	0.00	1.00	0.0000	15	dur
1-76-0-Q/01-78-1-F	N/A	0.00	1.00	0.0000	26	dur

 Path no. 33 Path Length 4

Compt ID	Cum L	Ign Mode	EB Time	Compt Fuel	Therm IAM	Dur IAM	FRI Time	CBO
4-82-0-E	0.8710	orig	0	5.4	N/A	N/A	3	
1-76-0-Q	0.8852	therm	5	0.0	0.200	0.110	7	11
01-78-3-E	0.9467	therm	8	10.0	0.824	0.536	10	
01-68-1-L	0.9789	therm	25	71.1	0.603	0.344	30	

Connecting Barrier	HEI	Tbar	Dbar	IBV	Time Destroyed	Failure Type
--------------------	-----	------	------	-----	----------------	--------------

4-82-0-E/1-76-0-Q	N/A	0.00	1.00	0.0000	15	dur
1-76-0-Q/01-78-3-E	N/A	0.00	1.00	0.0000	17	dur
01-78-3-E/01-68-1-L	47.5	1.00	0.00	0.0000		therm

 Path no. 34 Path Length 4

Compt ID	Cum L	Ign Mode	EB Time	Compt Fuel	Therm IAM	Dur IAM	FRI Time	CBO
4-82-0-E	0.8710	orig	0	5.4	N/A	N/A	3	
1-76-0-Q	0.8852	therm	5	0.0	0.200	0.110	7	11
01-78-3-E	0.9467	therm	8	10.0	0.824	0.536	10	
01-78-1-F	0.9467	dur	8	68.1	0.000	0.000		8

Connecting Barrier	HEI	Tbar	Dbar	IBV	Time Destroyed	Failure Type
4-82-0-E/1-76-0-Q	N/A	0.00	1.00	0.0000	15	dur
1-76-0-Q/01-78-3-E	N/A	0.00	1.00	0.0000	17	dur
01-78-3-E/01-78-1-F	40.2	1.00	0.00	0.0000		therm

 Path no. 35 Path Length 4

Compt ID	Cum L	Ign Mode	EB Time	Compt Fuel	Therm IAM	Dur IAM	FRI Time	CBO
4-82-0-E	0.8710	orig	0	5.4	N/A	N/A	3	
1-76-0-Q	0.8852	therm	5	0.0	0.200	0.110	7	11
01-78-3-E	0.9467	therm	8	10.0	0.824	0.536	10	
01-86-1-L	0.9856	therm	25	45.4	0.730	0.419		

Connecting Barrier	HEI	Tbar	Dbar	IBV	Time Destroyed	Failure Type
4-82-0-E/1-76-0-Q	N/A	0.00	1.00	0.0000	15	dur
1-76-0-Q/01-78-3-E	N/A	0.00	1.00	0.0000	17	dur
01-78-3-E/01-86-1-L	26.9	1.00	0.00	0.0000		therm

 Path no. 36 Path Length 3

Compt ID	Cum L	Ign Mode	EB Time	Compt Fuel	Therm IAM	Dur IAM	FRI Time	CBO
4-82-0-E	0.8710	orig	0	5.4	N/A	N/A	3	
1-76-0-Q	0.8852	therm	5	0.0	0.200	0.110	7	11
01-79-0A-L	0.9850	dur	8	14.9	0.933	0.870	21	

Connecting Barrier	HEI	Tbar	Dbar	IBV	Time Destroyed	Failure Type
4-82-0-E/1-76-0-Q	N/A	0.00	1.00	0.0000	15	dur
1-76-0-Q/01-79-0A-L	N/A	0.00	1.00	0.0000	23	dur

 Path no. 37 Path Length 3

Compt ID	Cum L	Ign Mode	EB Time	Compt Fuel	Therm IAM	Dur IAM	FRI Time	CBO
4-82-0-E	0.8710	orig	0	5.4	N/A	N/A	3	
1-76-0-Q	0.8852	therm	5	0.0	0.200	0.110	7	11
01-79-0A-L	0.9850	dur	8	14.9	0.933	0.870	21	

4-82-0-E	0.8710	orig	0	5.4	N/A	N/A	3	
1-76-0-Q	0.8852	therm	5	0.0	0.200	0.110	7	11
01-79-0B-L	0.9850	dur	6	19.4	0.933	0.870	17	

Connecting Barrier	HEI	Tbar	Dbar	IBV	Time Destroyed	Failure Type
4-82-0-E/1-76-0-Q	N/A	0.00	1.00	0.0000	15	dur
1-76-0-Q/01-79-0B-L	N/A	0.00	1.00	0.0000	21	dur

 Path no. 38 Path Length 3

Compt ID	Cum L	Ign Mode	EB Time	Compt Fuel	Therm IAM	Dur IAM	FRI Time	CBO
4-82-0-E	0.8710	orig	0	5.4	N/A	N/A	3	
1-76-0-Q	0.8852	therm	5	0.0	0.200	0.110	7	11
02-85-0-Q	0.9503	therm	8	63.2	0.827	0.567	34	

Connecting Barrier	HEI	Tbar	Dbar	IBV	Time Destroyed	Failure Type
4-82-0-E/1-76-0-Q	N/A	0.00	1.00	0.0000	15	dur
1-76-0-Q/02-85-0-Q	N/A	0.00	1.00	0.0000	26	dur

 Path no. 39 Path Length 4

Compt ID	Cum L	Ign Mode	EB Time	Compt Fuel	Therm IAM	Dur IAM	FRI Time	CBO
4-82-0-E	0.8710	orig	0	5.4	N/A	N/A	3	
1-76-0-Q	0.8852	therm	5	0.0	0.200	0.110	7	11
4-66-0-E	0.9528	dur	7	0.0	0.897	0.589	8	31
3-57-0-A	0.9738	therm	12	68.1	0.745	0.446	17	

Connecting Barrier	HEI	Tbar	Dbar	IBV	Time Destroyed	Failure Type
4-82-0-E/1-76-0-Q	N/A	0.00	1.00	0.0000	15	dur
1-76-0-Q/4-66-0-E	N/A	0.00	1.00	0.0000	7	dur
4-66-0-E/3-57-0-A	N/A	0.00	1.00	0.0000	35	dur

 Path no. 40 Path Length 4

Compt ID	Cum L	Ign Mode	EB Time	Compt Fuel	Therm IAM	Dur IAM	FRI Time	CBO
4-82-0-E	0.8710	orig	0	5.4	N/A	N/A	3	
1-76-0-Q	0.8852	therm	5	0.0	0.200	0.110	7	11
4-66-0-E	0.9528	dur	7	0.0	0.897	0.589	8	31
2-57-1-Q	0.9706	therm	12	54.8	0.646	0.376	18	

Connecting Barrier	HEI	Tbar	Dbar	IBV	Time Destroyed	Failure Type
4-82-0-E/1-76-0-Q	N/A	0.00	1.00	0.0000	15	dur
1-76-0-Q/4-66-0-E	N/A	0.00	1.00	0.0000	7	dur
4-66-0-E/2-57-1-Q	N/A	0.00	1.00	0.0000	38	dur

 Path no. 41 Path Length 5

Compt ID	Cum L	Ign Mode	EB Time	Compt Fuel	Therm IAM	Dur IAM	FRI Time	CBO
4-82-0-E	0.8710	orig	0	5.4	N/A	N/A	3	
1-76-0-Q	0.8852	therm	5	0.0	0.200	0.110	7	11
4-66-0-E	0.9528	dur	7	0.0	0.897	0.589	8	31
2-57-4-E	0.9721	therm	12	40.4	0.570	0.409	14	
2-57-2-A	0.9845	therm	52	0.0	0.745	0.446	56	60

Connecting Barrier	HEI	Tbar	Dbar	IBV	Time Destroyed	Failure Type
4-82-0-E/1-76-0-Q	N/A	0.00	1.00	0.0000	15	dur
1-76-0-Q/4-66-0-E	N/A	0.00	1.00	0.0000	7	dur
4-66-0-E/2-57-4-E	N/A	0.00	1.00	0.0000	35	dur
2-57-4-E/2-57-2-A	N/A	0.00	1.00	0.0000	59	dur

 Path no. 42 Path Length 5

Compt ID	Cum L	Ign Mode	EB Time	Compt Fuel	Therm IAM	Dur IAM	FRI Time	CBO
4-82-0-E	0.8710	orig	0	5.4	N/A	N/A	3	
1-76-0-Q	0.8852	therm	5	0.0	0.200	0.110	7	11
4-66-0-E	0.9528	dur	7	0.0	0.897	0.589	8	31
2-57-4-E	0.9721	therm	12	40.4	0.570	0.409	14	
1-60-6B-A	0.9845	dur	16	0.0	0.745	0.446	17	20

Connecting Barrier	HEI	Tbar	Dbar	IBV	Time Destroyed	Failure Type
4-82-0-E/1-76-0-Q	N/A	0.00	1.00	0.0000	15	dur
1-76-0-Q/4-66-0-E	N/A	0.00	1.00	0.0000	7	dur
4-66-0-E/2-57-4-E	N/A	0.00	1.00	0.0000	35	dur
2-57-4-E/1-60-6B-A	N/A	0.00	1.00	0.0000	24	dur

 Path no. 43 Path Length 4

Compt ID	Cum L	Ign Mode	EB Time	Compt Fuel	Therm IAM	Dur IAM	FRI Time	CBO
4-82-0-E	0.8710	orig	0	5.4	N/A	N/A	3	
1-76-0-Q	0.8852	therm	5	0.0	0.200	0.110	7	11
4-66-0-E	0.9528	dur	7	0.0	0.897	0.589	8	31
2-59-1-Q	0.9706	therm	12	54.6	0.646	0.376	17	

Connecting Barrier	HEI	Tbar	Dbar	IBV	Time Destroyed	Failure Type
4-82-0-E/1-76-0-Q	N/A	0.00	1.00	0.0000	15	dur
1-76-0-Q/4-66-0-E	N/A	0.00	1.00	0.0000	7	dur
4-66-0-E/2-59-1-Q	N/A	0.00	1.00	0.0000	37	dur

 Path no. 44 Path Length 4

Compt ID	Cum L	Ign Mode	EB Time	Compt Fuel	Therm IAM	Dur IAM	FRI Time	CBO
----------	-------	----------	---------	------------	-----------	---------	----------	-----

Compt ID	Cum L	Ign Mode	EB Time	Compt Fuel	Therm IAM	Dur IAM	FRI Time	CBO
4-82-0-E	0.8710	orig	0	5.4	N/A	N/A	3	
1-76-0-Q	0.8852	therm	5	0.0	0.200	0.110	7	11
4-66-0-E	0.9528	dur	7	0.0	0.897	0.589	8	31
1-60-6A-A	0.9738	therm	12	6.2	0.745	0.446	16	18

Connecting Barrier	HEI	Tbar	Dbar	IBV	Time Destroyed	Failure Type
4-82-0-E/1-76-0-Q	N/A	0.00	1.00	0.0000	15	dur
1-76-0-Q/4-66-0-E	N/A	0.00	1.00	0.0000	7	dur
4-66-0-E/1-60-6A-A	N/A	0.00	1.00	0.0000	21	dur

 Path no. 45 Path Length 5

Compt ID	Cum L	Ign Mode	EB Time	Compt Fuel	Therm IAM	Dur IAM	FRI Time	CBO
4-82-0-E	0.8710	orig	0	5.4	N/A	N/A	3	
1-76-0-Q	0.8852	therm	5	0.0	0.200	0.110	7	11
4-66-0-E	0.9528	dur	7	0.0	0.897	0.589	8	31
1-60-6A-A	0.9738	therm	12	6.2	0.745	0.446	16	18
01-70-2-Q	0.9813	dur	17	15.4	0.531	0.286	35	

Connecting Barrier	HEI	Tbar	Dbar	IBV	Time Destroyed	Failure Type
4-82-0-E/1-76-0-Q	N/A	0.00	1.00	0.0000	15	dur
1-76-0-Q/4-66-0-E	N/A	0.00	1.00	0.0000	7	dur
4-66-0-E/1-60-6A-A	N/A	0.00	1.00	0.0000	21	dur
1-60-6A-A/01-70-2-Q	N/A	0.00	1.00	0.0000	28	dur

 Path no. 46 Path Length 5

Compt ID	Cum L	Ign Mode	EB Time	Compt Fuel	Therm IAM	Dur IAM	FRI Time	CBO
4-82-0-E	0.8710	orig	0	5.4	N/A	N/A	3	
1-76-0-Q	0.8852	therm	5	0.0	0.200	0.110	7	11
4-66-0-E	0.9528	dur	7	0.0	0.897	0.589	8	31
1-60-6A-A	0.9738	therm	12	6.2	0.745	0.446	16	18
1-60-6B-A	0.9855	dur	16	0.0	0.745	0.446	17	20

Connecting Barrier	HEI	Tbar	Dbar	IBV	Time Destroyed	Failure Type
4-82-0-E/1-76-0-Q	N/A	0.00	1.00	0.0000	15	dur
1-76-0-Q/4-66-0-E	N/A	0.00	1.00	0.0000	7	dur
4-66-0-E/1-60-6A-A	N/A	0.00	1.00	0.0000	21	dur
1-60-6A-A/1-60-6B-A	N/A	0.00	1.00	0.0000	16	dur

 Path no. 47 Path Length 5

Compt ID	Cum L	Ign Mode	EB Time	Compt Fuel	Therm IAM	Dur IAM	FRI Time	CBO
4-82-0-E	0.8710	orig	0	5.4	N/A	N/A	3	
1-76-0-Q	0.8852	therm	5	0.0	0.200	0.110	7	11
4-66-0-E	0.9528	dur	7	0.0	0.897	0.589	8	31
1-60-6A-A	0.9738	therm	12	6.2	0.745	0.446	16	18

1-71-2-Q 0.9818 therm 12 34.2 0.565 0.303 17

Connecting Barrier	HEI	Tbar	Dbar	IBV	Time Destroyed	Failure Type
4-82-0-E/1-76-0-Q	N/A	0.00	1.00	0.0000	15	dur
1-76-0-Q/4-66-0-E	N/A	0.00	1.00	0.0000	7	dur
4-66-0-E/1-60-6A-A	N/A	0.00	1.00	0.0000	21	dur
1-60-6A-A/1-71-2-Q	N/A	0.00	1.00	0.0000	21	dur

 Path no. 48 Path Length 4

Compt ID	Cum L	Ign Mode	EB Time	Compt Fuel	Therm IAM	Dur IAM	FRI Time	CBO
4-82-0-E	0.8710	orig	0	5.4	N/A	N/A	3	
1-76-0-Q	0.8852	therm	5	0.0	0.200	0.110	7	11
4-66-0-E	0.9528	dur	7	0.0	0.897	0.589	8	31
1-66-0-L	0.9796	dur	7	20.4	0.657	0.369	30	

Connecting Barrier	HEI	Tbar	Dbar	IBV	Time Destroyed	Failure Type
4-82-0-E/1-76-0-Q	N/A	0.00	1.00	0.0000	15	dur
1-76-0-Q/4-66-0-E	N/A	0.00	1.00	0.0000	7	dur
4-66-0-E/1-66-0-L	N/A	0.69	0.31	0.0000	54	therm

 Path no. 49 Path Length 4

Compt ID	Cum L	Ign Mode	EB Time	Compt Fuel	Therm IAM	Dur IAM	FRI Time	CBO
4-82-0-E	0.8710	orig	0	5.4	N/A	N/A	3	
1-76-0-Q	0.8852	therm	5	0.0	0.200	0.110	7	11
4-66-0-E	0.9528	dur	7	0.0	0.897	0.589	8	31
1-71-2-Q	0.9742	therm	12	34.2	0.565	0.303	17	

Connecting Barrier	HEI	Tbar	Dbar	IBV	Time Destroyed	Failure Type
4-82-0-E/1-76-0-Q	N/A	0.00	1.00	0.0000	15	dur
1-76-0-Q/4-66-0-E	N/A	0.00	1.00	0.0000	7	dur
4-66-0-E/1-71-2-Q	N/A	0.57	0.43	-0.0000	51	therm

 Path no. 50 Path Length 4

Compt ID	Cum L	Ign Mode	EB Time	Compt Fuel	Therm IAM	Dur IAM	FRI Time	CBO
4-82-0-E	0.8710	orig	0	5.4	N/A	N/A	3	
1-76-0-Q	0.8852	therm	5	0.0	0.200	0.110	7	11
4-66-0-E	0.9528	dur	7	0.0	0.897	0.589	8	31
1-74-2-Q	0.9836	therm	12	28.6	0.680	0.506		

Connecting Barrier	HEI	Tbar	Dbar	IBV	Time Destroyed	Failure Type
4-82-0-E/1-76-0-Q	N/A	0.00	1.00	0.0000	15	dur
1-76-0-Q/4-66-0-E	N/A	0.00	1.00	0.0000	7	dur

4-66-0-E/1-74-2-Q N/A 0.85 0.15 0.0000 59 therm

 Path no. 51 Path Length 4

Compt ID	Cum L	Ign Mode	EB Time	Compt Fuel	Therm IAM	Dur IAM	FRI Time	CBO
4-82-0-E	0.8710	orig	0	5.4	N/A	N/A	3	
1-76-0-Q	0.8852	therm	5	0.0	0.200	0.110	7	11
4-66-0-E	0.9528	dur	7	0.0	0.897	0.589	8	31
1-77-1-A	0.9751	therm	8	135.9	0.531	0.286	35	

Connecting Barrier	HEI	Tbar	Dbar	IBV	Time Destroyed	Failure Type
4-82-0-E/1-76-0-Q	N/A	0.00	1.00	0.0000	15	dur
1-76-0-Q/4-66-0-E	N/A	0.00	1.00	0.0000	7	dur
4-66-0-E/1-77-1-A	N/A	0.76	0.24	-0.0000	56	therm

 Path no. 52 Path Length 4

Compt ID	Cum L	Ign Mode	EB Time	Compt Fuel	Therm IAM	Dur IAM	FRI Time	CBO
4-82-0-E	0.8710	orig	0	5.4	N/A	N/A	3	
1-76-0-Q	0.8852	therm	5	0.0	0.200	0.110	7	11
4-66-0-E	0.9528	dur	7	0.0	0.897	0.589	8	31
1-77-2-L	0.9817	therm	12	51.2	0.657	0.369		

Connecting Barrier	HEI	Tbar	Dbar	IBV	Time Destroyed	Failure Type
4-82-0-E/1-76-0-Q	N/A	0.00	1.00	0.0000	15	dur
1-76-0-Q/4-66-0-E	N/A	0.00	1.00	0.0000	7	dur
4-66-0-E/1-77-2-L	N/A	0.85	0.15	0.0000	59	therm

 Path no. 53 Path Length 4

Compt ID	Cum L	Ign Mode	EB Time	Compt Fuel	Therm IAM	Dur IAM	FRI Time	CBO
4-82-0-E	0.8710	orig	0	5.4	N/A	N/A	3	
1-76-0-Q	0.8852	therm	5	0.0	0.200	0.110	7	11
4-66-0-E	0.9528	dur	7	0.0	0.897	0.589	8	31
1-77-3-L	0.9793	therm	12	57.9	0.657	0.369	33	

Connecting Barrier	HEI	Tbar	Dbar	IBV	Time Destroyed	Failure Type
4-82-0-E/1-76-0-Q	N/A	0.00	1.00	0.0000	15	dur
1-76-0-Q/4-66-0-E	N/A	0.00	1.00	0.0000	7	dur
4-66-0-E/1-77-3-L	N/A	0.67	0.33	0.0000	54	therm

 Path no. 54 Path Length 4

Compt ID	Cum L	Ign Mode	EB Time	Compt Fuel	Therm IAM	Dur IAM	FRI Time	CBO
4-82-0-E	0.8710	orig	0	5.4	N/A	N/A	3	

1-76-0-Q	0.8852	therm	5	0.0	0.200	0.110	7	11
4-66-0-E	0.9528	dur	7	0.0	0.897	0.589	8	31
2-89-1-C	0.9714	dur	8	38.3	0.655	0.394	9	

Connecting Barrier	HEI	Tbar	Dbar	IBV	Time Destroyed	Failure Type
4-82-0-E/1-76-0-Q	N/A	0.00	1.00	0.0000	15	dur
1-76-0-Q/4-66-0-E	N/A	0.00	1.00	0.0000	7	dur
4-66-0-E/2-89-1-C	N/A	0.00	1.00	0.0000	28	dur

 Path no. 55 Path Length 5

Compt ID	Cum L	Ign Mode	EB Time	Compt Fuel	Therm IAM	Dur IAM	FRI Time	CBO
4-82-0-E	0.8710	orig	0	5.4	N/A	N/A	3	
1-76-0-Q	0.8852	therm	5	0.0	0.200	0.110	7	11
4-66-0-E	0.9528	dur	7	0.0	0.897	0.589	8	31
2-89-1-C	0.9714	dur	8	38.3	0.655	0.394	9	
4-66-0-E	0.9882	dur	7	0.0	0.897	0.589	8	31

Connecting Barrier	HEI	Tbar	Dbar	IBV	Time Destroyed	Failure Type
4-82-0-E/1-76-0-Q	N/A	0.00	1.00	0.0000	15	dur
1-76-0-Q/4-66-0-E	N/A	0.00	1.00	0.0000	7	dur
4-66-0-E/2-89-1-C	N/A	0.00	1.00	0.0000	28	dur
2-89-1-C/4-66-0-E	132.8	0.00	1.00	0.0000	28	dur

 Path no. 56 Path Length 3

Compt ID	Cum L	Ign Mode	EB Time	Compt Fuel	Therm IAM	Dur IAM	FRI Time	CBO
4-82-0-E	0.8710	orig	0	5.4	N/A	N/A	3	
1-76-0-Q	0.8852	therm	5	0.0	0.200	0.110	7	11
1-66-0-L	0.9275	dur	7	20.4	0.657	0.369	30	

Connecting Barrier	HEI	Tbar	Dbar	IBV	Time Destroyed	Failure Type
4-82-0-E/1-76-0-Q	N/A	0.00	1.00	0.0000	15	dur
1-76-0-Q/1-66-0-L	N/A	0.00	1.00	0.0000	22	dur

 Path no. 57 Path Length 4

Compt ID	Cum L	Ign Mode	EB Time	Compt Fuel	Therm IAM	Dur IAM	FRI Time	CBO
4-82-0-E	0.8710	orig	0	5.4	N/A	N/A	3	
1-76-0-Q	0.8852	therm	5	0.0	0.200	0.110	7	11
1-66-0-L	0.9275	dur	7	20.4	0.657	0.369	30	
01-68-1-L	0.9829	therm	25	71.1	0.603	0.344	30	

Connecting Barrier	HEI	Tbar	Dbar	IBV	Time Destroyed	Failure Type
4-82-0-E/1-76-0-Q	N/A	0.00	1.00	0.0000	15	dur

1-76-0-Q/1-66-0-L	N/A	0.00	1.00	0.0000	22				dur
1-66-0-L/01-68-1-L	6.4	0.59	0.00	0.0294					therm

 Path no. 58 Path Length 4

Compt ID	Cum L	Ign Mode	EB Time	Compt Fuel	Therm IAM	Dur IAM	FRI Time	CBO
4-82-0-E	0.8710	orig	0	5.4	N/A	N/A	3	
1-76-0-Q	0.8852	therm	5	0.0	0.200	0.110	7	11
1-66-0-L	0.9275	dur	7	20.4	0.657	0.369	30	
1-77-1-A	0.9821	therm	8	135.9	0.531	0.286	35	

Connecting Barrier	HEI	Tbar	Dbar	IBV	Time Destroyed	Failure Type
4-82-0-E/1-76-0-Q	N/A	0.00	1.00	0.0000	15	dur
1-76-0-Q/1-66-0-L	N/A	0.00	1.00	0.0000	22	dur
1-66-0-L/1-77-1-A	4.4	0.53	0.00	0.0343		therm

 Path no. 59 Path Length 4

Compt ID	Cum L	Ign Mode	EB Time	Compt Fuel	Therm IAM	Dur IAM	FRI Time	CBO
4-82-0-E	0.8710	orig	0	5.4	N/A	N/A	3	
1-76-0-Q	0.8852	therm	5	0.0	0.200	0.110	7	11
1-66-0-L	0.9275	dur	7	20.4	0.657	0.369	30	
01-68-0-Q	0.9685	therm	8	94.7	0.565	0.303	13	

Connecting Barrier	HEI	Tbar	Dbar	IBV	Time Destroyed	Failure Type
4-82-0-E/1-76-0-Q	N/A	0.00	1.00	0.0000	15	dur
1-76-0-Q/1-66-0-L	N/A	0.00	1.00	0.0000	22	dur
1-66-0-L/01-68-0-Q	16.1	1.00	0.00	0.0000		therm

 Path no. 60 Path Length 4

Compt ID	Cum L	Ign Mode	EB Time	Compt Fuel	Therm IAM	Dur IAM	FRI Time	CBO
4-82-0-E	0.8710	orig	0	5.4	N/A	N/A	3	
1-76-0-Q	0.8852	therm	5	0.0	0.200	0.110	7	11
1-66-0-L	0.9275	dur	7	20.4	0.657	0.369	30	
1-66-1-Q	0.9693	dur	12	4.2	0.866	0.576	34	

Connecting Barrier	HEI	Tbar	Dbar	IBV	Time Destroyed	Failure Type
4-82-0-E/1-76-0-Q	N/A	0.00	1.00	0.0000	15	dur
1-76-0-Q/1-66-0-L	N/A	0.00	1.00	0.0000	22	dur
1-66-0-L/1-66-1-Q	0.1	0.00	1.00	0.0000	30	dur

 Path no. 61 Path Length 5

Compt ID	Cum L	Ign Mode	EB Time	Compt Fuel	Therm IAM	Dur IAM	FRI Time	CBO
----------	-------	----------	---------	------------	-----------	---------	----------	-----

4-82-0-E	0.8710	orig	0	5.4	N/A	N/A	3	
1-76-0-Q	0.8852	therm	5	0.0	0.200	0.110	7	11
1-66-0-L	0.9275	dur	7	20.4	0.657	0.369	30	
1-66-1-Q	0.9693	dur	12	4.2	0.866	0.576	34	
1-66-0-L	0.9806	dur	7	20.4	0.657	0.369	30	

Connecting Barrier	HEI	Tbar	Dbar	IBV	Time Destroyed	Failure Type
4-82-0-E/1-76-0-Q	N/A	0.00	1.00	0.0000	15	dur
1-76-0-Q/1-66-0-L	N/A	0.00	1.00	0.0000	22	dur
1-66-0-L/1-66-1-Q	0.1	0.00	1.00	0.0000	30	dur
1-66-1-Q/1-66-0-L	0.1	0.00	1.00	0.0000	30	dur

 Path no. 62 Path Length 5

Compt ID	Cum L	Ign Mode	EB Time	Compt Fuel	Therm IAM	Dur IAM	FRI Time	CBO
4-82-0-E	0.8710	orig	0	5.4	N/A	N/A	3	
1-76-0-Q	0.8852	therm	5	0.0	0.200	0.110	7	11
1-66-0-L	0.9275	dur	7	20.4	0.657	0.369	30	
1-66-1-Q	0.9693	dur	12	4.2	0.866	0.576	34	
01-68-0-Q	0.9866	therm	8	94.7	0.565	0.303	13	

Connecting Barrier	HEI	Tbar	Dbar	IBV	Time Destroyed	Failure Type
4-82-0-E/1-76-0-Q	N/A	0.00	1.00	0.0000	15	dur
1-76-0-Q/1-66-0-L	N/A	0.00	1.00	0.0000	22	dur
1-66-0-L/1-66-1-Q	0.1	0.00	1.00	0.0000	30	dur
1-66-1-Q/01-68-0-Q	13.4	1.00	0.00	0.0000		therm

 Path no. 63 Path Length 3

Compt ID	Cum L	Ign Mode	EB Time	Compt Fuel	Therm IAM	Dur IAM	FRI Time	CBO
4-82-0-E	0.8710	orig	0	5.4	N/A	N/A	3	
1-76-0-Q	0.8852	therm	5	0.0	0.200	0.110	7	11
01-60-0A-L	0.9850	dur	7	30.5	0.933	0.870	30	

Connecting Barrier	HEI	Tbar	Dbar	IBV	Time Destroyed	Failure Type
4-82-0-E/1-76-0-Q	N/A	0.00	1.00	0.0000	15	dur
1-76-0-Q/01-60-0A-L	N/A	0.00	1.00	0.0000	22	dur

 Path no. 64 Path Length 3

Compt ID	Cum L	Ign Mode	EB Time	Compt Fuel	Therm IAM	Dur IAM	FRI Time	CBO
4-82-0-E	0.8710	orig	0	5.4	N/A	N/A	3	
1-76-0-Q	0.8852	therm	5	0.0	0.200	0.110	7	11
01-74-1-L	0.9774	dur	7	34.4	0.947	0.803	30	

Connecting Barrier	HEI	Tbar	Dbar	IBV	Time Destroyed	Failure Type
--------------------	-----	------	------	-----	----------------	--------------

4-82-0-E/1-76-0-Q	N/A	0.00	1.00	0.0000	15	dur
1-76-0-Q/01-74-1-L	N/A	0.00	1.00	0.0000	22	dur

 Path no. 65 Path Length 4

Compt ID	Cum L	Ign Mode	EB Time	Compt Fuel	Therm IAM	Dur IAM	FRI Time	CBO
4-82-0-E	0.8710	orig	0	5.4	N/A	N/A	3	
1-76-0-Q	0.8852	therm	5	0.0	0.200	0.110	7	11
02-73-0-Q	0.9587	therm	7	38.7	1.000	0.640	9	
03-76-0-Q	0.9699	therm	7	10.5	0.272	0.146	9	

Connecting Barrier	HEI	Tbar	Dbar	IBV	Time Destroyed	Failure Type
4-82-0-E/1-76-0-Q	N/A	0.00	1.00	0.0000	15	dur
1-76-0-Q/02-73-0-Q	N/A	0.00	1.00	0.0000	17	dur
02-73-0-Q/03-76-0-Q	38.0	1.00	0.00	0.0000		therm

 Path no. 66 Path Length 3

Compt ID	Cum L	Ign Mode	EB Time	Compt Fuel	Therm IAM	Dur IAM	FRI Time	CBO
4-82-0-E	0.8710	orig	0	5.4	N/A	N/A	3	
1-76-0-Q	0.8852	therm	5	0.0	0.200	0.110	7	11
03-76-0-Q	0.9019	therm	7	10.5	0.272	0.146	9	

Connecting Barrier	HEI	Tbar	Dbar	IBV	Time Destroyed	Failure Type
4-82-0-E/1-76-0-Q	N/A	0.00	1.00	0.0000	15	dur
1-76-0-Q/03-76-0-Q	N/A	0.00	1.00	0.0000	21	dur

 Path no. 67 Path Length 4

Compt ID	Cum L	Ign Mode	EB Time	Compt Fuel	Therm IAM	Dur IAM	FRI Time	CBO
4-82-0-E	0.8710	orig	0	5.4	N/A	N/A	3	
1-76-0-Q	0.8852	therm	5	0.0	0.200	0.110	7	11
1-80-1-Q	0.9614	dur	7	42.3	1.000	0.664	30	
03-76-0-Q	0.9719	therm	7	10.5	0.272	0.146	9	

Connecting Barrier	HEI	Tbar	Dbar	IBV	Time Destroyed	Failure Type
4-82-0-E/1-76-0-Q	N/A	0.00	1.00	0.0000	15	dur
1-76-0-Q/1-80-1-Q	N/A	0.00	1.00	0.0000	22	dur
1-80-1-Q/03-76-0-Q	30.5	1.00	0.00	0.0000		therm

 Path no. 68 Path Length 2

Compt ID	Cum L	Ign Mode	EB Time	Compt Fuel	Therm IAM	Dur IAM	FRI Time	CBO
4-82-0-E	0.8710	orig	0	5.4	N/A	N/A	3	

1-82-0-L 0.9875 dur 5 26.0 0.933 0.870 10

Connecting Barrier	HEI	Tbar	Dbar	IBV	Time Destroyed	Failure Type
4-82-0-E/1-82-0-L	N/A	0.53	0.47	-0.0000	51	therm

Path no. 69 Path Length 2

Compt ID	Cum L	Ign Mode	EB Time	Compt Fuel	Therm IAM	Dur IAM	FRI Time	CBO
4-82-0-E	0.8710	orig	0	5.4	N/A	N/A	3	
1-85-2-Q	0.9296	therm	5	0.1	0.620	0.454	6	8

Connecting Barrier	HEI	Tbar	Dbar	IBV	Time Destroyed	Failure Type
4-82-0-E/1-85-2-Q	N/A	0.00	1.00	0.0000	9	dur

Path no. 70 Path Length 3

Compt ID	Cum L	Ign Mode	EB Time	Compt Fuel	Therm IAM	Dur IAM	FRI Time	CBO
4-82-0-E	0.8710	orig	0	5.4	N/A	N/A	3	
1-85-2-Q	0.9296	therm	5	0.1	0.620	0.454	6	8
1-85-1-L	0.9647	dur	6	50.0	0.803	0.500	17	

Connecting Barrier	HEI	Tbar	Dbar	IBV	Time Destroyed	Failure Type
4-82-0-E/1-85-2-Q	N/A	0.00	1.00	0.0000	9	dur
1-85-2-Q/1-85-1-L	N/A	0.00	1.00	0.0000	11	dur

Path no. 71 Path Length 3

Compt ID	Cum L	Ign Mode	EB Time	Compt Fuel	Therm IAM	Dur IAM	FRI Time	CBO
4-82-0-E	0.8710	orig	0	5.4	N/A	N/A	3	
1-85-2-Q	0.9296	therm	5	0.1	0.620	0.454	6	8
01-88-0-L	0.9591	dur	6	42.7	0.730	0.419	17	

Connecting Barrier	HEI	Tbar	Dbar	IBV	Time Destroyed	Failure Type
4-82-0-E/1-85-2-Q	N/A	0.00	1.00	0.0000	9	dur
1-85-2-Q/01-88-0-L	N/A	0.00	1.00	0.0000	12	dur

Path no. 72 Path Length 2

Compt ID	Cum L	Ign Mode	EB Time	Compt Fuel	Therm IAM	Dur IAM	FRI Time	CBO
4-82-0-E	0.8710	orig	0	5.4	N/A	N/A	3	
1-84-2-L	0.9866	dur	3	10.0	0.955	0.897	7	

Connecting Barrier	HEI	Tbar	Dbar	IBV	Time Destroyed	Failure Type
4-82-0-E/1-84-2-L	N/A	0.00	1.00	0.0000	3	dur

PATH OPTION - DETAIL LEVEL REPORT

INFORMATION ON ALL PATHS FROM 4-12-0-E

READINESS CONDITION . YOKE
 CONFIGURATION Passive, Automatic, and Manual
 CASE Worst
 ASSUMED LOCATION . . . at SEA
 RUN TIME 60 minutes
 COMMENTS
 Ship Visit Baseline
 At Sea

 Path no. 1 Path Length 1

Compt ID	Cum L	Ign Mode	EB Time	Compt Fuel	Therm IAM	Dur IAM	FRI Time	CBO
4-12-0-E	0.9110	orig	0	20.2	N/A	N/A	3	

Connecting Barrier	HEI	Tbar	Dbar	IBV	Time Destroyed	Failure Type

 Path no. 2 Path Length 2

Compt ID	Cum L	Ign Mode	EB Time	Compt Fuel	Therm IAM	Dur IAM	FRI Time	CBO
4-12-0-E	0.9110	orig	0	20.2	N/A	N/A	3	
1-12-3-Q	0.9685	therm	16	68.9	0.646	0.376	27	

Connecting Barrier	HEI	Tbar	Dbar	IBV	Time Destroyed	Failure Type
4-12-0-E/1-12-3-Q	12.4	1.00	0.00	0.0000		therm

 Path no. 3 Path Length 2

Compt ID	Cum L	Ign Mode	EB Time	Compt Fuel	Therm IAM	Dur IAM	FRI Time	CBO
4-12-0-E	0.9110	orig	0	20.2	N/A	N/A	3	
1-18-1-Q	0.9621	therm	16	52.4	0.570	0.409	18	

Connecting Barrier	HEI	Tbar	Dbar	IBV	Time Destroyed	Failure Type
4-12-0-E/1-18-1-Q	11.9	0.99	0.00	0.0008		therm

 Path no. 4 Path Length 2

Compt ID	Cum L	Ign Mode	EB Time	Compt Fuel	Therm IAM	Dur IAM	FRI Time	CBO
----------	-------	----------	---------	------------	-----------	---------	----------	-----

4-12-0-E	0.9110	orig	0	20.2	N/A	N/A	3	
1-18-2-Q	0.9462	therm	16	0.1	0.555	0.396	17	19

Connecting Barrier	HEI	Tbar	Dbar	IBV	Time Destroyed	Failure Type
4-12-0-E/1-18-2-Q	460.6	0.00	1.00	0.0000	22	dur

 Path no. 5 Path Length 3

Compt ID	Cum L	Ign Mode	EB Time	Compt Fuel	Therm IAM	Dur IAM	FRI Time	CBO
4-12-0-E	0.9110	orig	0	20.2	N/A	N/A	3	
1-18-2-Q	0.9462	therm	16	0.1	0.555	0.396	17	19
1-18-4-A	0.9702	therm	16	62.5	0.745	0.446	27	

Connecting Barrier	HEI	Tbar	Dbar	IBV	Time Destroyed	Failure Type
4-12-0-E/1-18-2-Q	460.6	0.00	1.00	0.0000	22	dur
1-18-2-Q/1-18-4-A	N/A	0.00	1.00	0.0000	26	dur

 Path no. 6 Path Length 3

Compt ID	Cum L	Ign Mode	EB Time	Compt Fuel	Therm IAM	Dur IAM	FRI Time	CBO
4-12-0-E	0.9110	orig	0	20.2	N/A	N/A	3	
1-18-2-Q	0.9462	therm	16	0.1	0.555	0.396	17	19
1-19-2-T	0.9819	dur	16	23.8	1.000	0.664	33	

Connecting Barrier	HEI	Tbar	Dbar	IBV	Time Destroyed	Failure Type
4-12-0-E/1-18-2-Q	460.6	0.00	1.00	0.0000	22	dur
1-18-2-Q/1-19-2-T	N/A	0.00	1.00	0.0000	26	dur

 Path no. 7 Path Length 3

Compt ID	Cum L	Ign Mode	EB Time	Compt Fuel	Therm IAM	Dur IAM	FRI Time	CBO
4-12-0-E	0.9110	orig	0	20.2	N/A	N/A	3	
1-18-2-Q	0.9462	therm	16	0.1	0.555	0.396	17	19
1-21-2-Q	0.9664	therm	17	61.9	0.646	0.376	19	

Connecting Barrier	HEI	Tbar	Dbar	IBV	Time Destroyed	Failure Type
4-12-0-E/1-18-2-Q	460.6	0.00	1.00	0.0000	22	dur
1-18-2-Q/1-21-2-Q	N/A	0.00	1.00	0.0000	23	dur

 Path no. 8 Path Length 2

Compt ID	Cum L	Ign Mode	EB Time	Compt Fuel	Therm IAM	Dur IAM	FRI Time	CBO
----------	-------	----------	---------	------------	-----------	---------	----------	-----

4-12-0-E	0.9110	orig	0	20.2	N/A	N/A	3
1-18-4-A	0.9778	therm	16	62.5	0.745	0.446	27

Connecting Barrier	HEI	Tbar	Dbar	IBV	Time Destroyed	Failure Type
4-12-0-E/1-18-4-A	11.7	0.98	0.00	0.0019		therm

.....
 Path no. 9 Path Length 2

Compt ID	Cum L	Ign Mode	EB Time	Compt Fuel	Therm IAM	Dur IAM	FRI Time	CBO
4-12-0-E	0.9110	orig	0	20.2	N/A	N/A	3	
2-21-1-A	0.9773	therm	11	99.1	0.745	0.446	17	

Connecting Barrier	HEI	Tbar	Dbar	IBV	Time Destroyed	Failure Type
4-12-0-E/2-21-1-A	41.7	1.00	0.00	0.0000		therm

.....
 Path no. 10 Path Length 2

Compt ID	Cum L	Ign Mode	EB Time	Compt Fuel	Therm IAM	Dur IAM	FRI Time	CBO
4-12-0-E	0.9110	orig	0	20.2	N/A	N/A	3	
2-21-2-Q	0.9617	therm	11	18.8	0.570	0.409	13	

Connecting Barrier	HEI	Tbar	Dbar	IBV	Time Destroyed	Failure Type
4-12-0-E/2-21-2-Q	27.0	1.00	0.00	0.0000		therm

WLB
07/02/96
MODEL RUN 23-166

PATH OPTION - DETAIL LEVEL REPORT

INFORMATION ON ALL PATHS FROM 2-30-0-AA

READINESS CONDITION . YOKE
CONFIGURATION Passive, Automatic, and Manual
CASE. Worst
ASSUMED LOCATION. at SEA
RUN TIME. 60 minutes
COMMENTS.
Ship Visit Baseline
At Sea

No fire paths resulted from this model run

WLB
 07/02/96
 MODEL RUN 23-167

PATH OPTION - DETAIL LEVEL REPORT

INFORMATION ON ALL PATHS FROM 1-85-3-L

READINESS CONDITION . YOKE
 CONFIGURATION Passive, Automatic, and Manual
 CASE Worst
 ASSUMED LOCATION . . . at SEA
 RUN TIME 60 minutes
 COMMENTS
 Ship Visit Baseline
 At Sea

Path no. 1 Path Length 2

Compt ID	Cum L	Ign Mode	EB Time	Compt Fuel	Therm IAM	Dur IAM	FRI Time	CBO
1-85-3-L	0.6966	orig	0	57.6	N/A	N/A	33	
1-92-1-L	0.9803	therm	48	53.4	0.803	0.500		

Connecting Barrier	HEI	Tbar	Dbar	IBV	Time Destroyed	Failure Type
1-85-3-L/1-92-1-L	3.0	0.33	0.00	0.2032		therm

Appendix D Preliminary Baseline Data and Results

The various input and output data produced in the performance of the preliminary baseline fire safety analysis on the U. S. Coast Guard Seagoing Buoy Tender replacement (WLB (R)) class of cutter using SAFE is documented in this Appendix. Data is only presented here that differs from the baseline data set shown in Appendix B.

The following is an index of the tables contained in this appendix.

D.1	Ventilation Openings: Area and Average Height	D-2
D.2	Barrier Data	D-6
D.3	Probability of Flame Termination, I, A, & M Values	D-50
D.4	Fuel Loads	D-54
D.5	Individual Target Output Option Results	
D.5.1	XRAY, In-Port, I, A, & M	D-58
D.5.2	XRAY, In-Port, I & A	D-59
D.5.3	XRAY, In-Port, I & M	D-60
D.5.4	XRAY, In-Port, I	D-61
D.5.5	YOKE, At Sea, I, A, & M	D-62
D.5.6	YOKE, At Sea, I & A	D-63
D.5.7	YOKE, At Sea, I & M	D-64
D.5.8	YOKE, At Sea, I	D-65
D.5.9	YOKE, In-Port, I, A, & M	D-66
D.5.10	YOKE, In-Port, I & A	D-67
D.5.11	YOKE, In-Port, I & M	D-68
D.5.12	YOKE, In-Port, I	D-69

Table D.1 Ventilation Openings: Area and Average Height

Plan ID	Compartment Name	Preliminary Baseline		Ship Visit	
		Total Area (ln2)	Avg.Height (ln.)	Total Area (ln2)	Avg.Height (ln.)
CUI=AA	(Cargo Hold)				
2-30-0-AA	CARGO HOLD	172	108	217	6
CUI=AG	(Gear Locker)				
3-6-0-Q	CHAIN LOCKER SUMP	246	10	246	10
2-6-1-Q	CHAIN LOCKER	246	10	246	10
2-6-2-Q	CHAIN LOCKER	246	10	246	10
1-77-1-A	CREW LOCKER	246	10	36	1
1-82-2-Q	C.G. LKR W/ SINK	246	10	261	7
01-70-2-Q	C.G. LKR	246	10	261	7
01-85-2-Q	FOUL WEATHER GEAR LKR	246	10	252	9
02-69-2-Q	CG LKR W/SINK	246	10	261	7
02-75-1-Q	PFD & SURVIVAL SUIT LOCKER	36	96	0	0
02-75-2-Q	PFD & SURVIVAL SUIT LOCKER	36	96	0	0
CUI=AR	(Refrigerated Storage)				
1-60-2-A	CHILL STRM	0	0	36	1
1-60-4-A	FREEZE STRM	0	0	36	1
CUI=AS	(Storeroom)				
3-57-0-A	SUPPLY DEPT. STOREROOM NO. 2	540	9	2160	96
2-21-1-A	SUPPLY DEPT STOREROOM NO. 1	540	9	36	1
2-50-1-A	ENGINEER STOREROOM	0	0	85	4
2-57-2-A	SHIP STORE	540	9	61	54
1-0-0-A	BOATSWAIN STOREROOM NO. 1	48	108	16	114
1-6-1-A	BOATSWAIN STOREROOM NO. 2	48	108	52	57
1-18-4-A	ATON STRM	86	102	4	2
1-60-6A-A	DRY PROVISION STOREROOM	540	9	68	39
1-60-6B-A	DRY PROVISION STOREROOM	540	9	144	1
1-102-2-A	DECK GEAR STOREROOM	36	96	140	24
CUI=C	(Ship Control/Communications)				
2-89-1-C	ENGINEERING CONTROL CENTER	342	71	315	65
01-27-0-C	BUOY DECK CONTROL BOOTH	214	43	36	1
02-66-0-C	RADIO ROOM	192	4	180	51
03-56-0A-C	PILOT HOUSE	192	4	4882	58
03-56-0B-C	PILOT HOUSE (CHART AREA)	192	4	1123	36
03-66-01-C	ELEX, IC & GYRO ROOM	307	71	159	8
CUI=EM	(Main Propulsion - Mechanical)				
4-12-0-E	BOWTHRUSTER MCHRY ROOM	61	108	612	240
4-66-0-E	MAIN MACHINERY ROOM	1496	240	2046	13
4-92-0-E	STERN THRUSTER MACHRY ROOM	61	108	193	125
1-102-0-E	STEERING GEAR ROOM	246	10	110	4
CUI=K	(Hazardous Material Storage)				
1-6-2-A	FLAM. LIQ. STOREROOM	0	100	61	3
CUI=L1	(Senior Officer's Cabin)				
02-57-0-L	CO CABIN	417	53	432	28
02-57-1-L	CO SR	96	4	486	28
02-57-4-L	XO SR	96	4	324	30
CUI=L2	(Officer/CPO Quarters)				
01-57-2-L	CPO SR	588	8	540	28
01-74-2-L	CPO SR	588	8	304	30
01-80-0-L	CREW SR	588	8	520	28
01-83-2-L	CPO SR	588	8	540	28
01-86-1-L	CREW SR	588	8	520	28
01-88-0-L	CREW SR	588	8	520	28
01-88-2-L	CREW SR	588	8	520	28

Table D.1 Ventilation Openings: Area and Average Height

Plan ID	Compartment Name	Preliminary Baseline		Ship Visit	
		Total Area (In2)	Avg.Height (In.)	Total Area (In2)	Avg.Height (In.)
02-63-2-L	OFFICER SR	588	8	540	28
02-69-1-L	OFFICER SR	588	8	540	28
02-69-4-L	OFFICER SR	588	8	540	28
CUI=L5	(Crews Berthing)				
1-85-1-L	CREW SR	588	8	520	30
1-85-3-L	CREW SR	588	8	520	30
1-85-4-L	CREW SR	588	8	520	30
1-92-1-L	CREW SR	588	8	520	30
1-92-2-L	CREW SR	588	8	520	30
1-96-0-L	CREW SR	588	8	520	30
CUI=LL	(Wardroom/Mess/Lounge Areas)				
1-66-0-L	CREW MESS	1176	8	10338	43
1-77-2-L	CPO MESS & LOUNGE	588	8	132	76
1-77-3-L	CREW LOUNGE	588	8	288	44
01-60-1-L	WARDROOM MESSROOM & LOUNGE	588	8	324	30
CUI=LM	(Medical/Dental Spaces)				
01-68-1-L	MEDICAL TREATMENT ROOM	588	8	360	24
CUI=LP	(Passageway/Staircase/Vestibule)				
3-21-0-L	PASSAGE	246	10	104	2
2-21-0-L	PASSAGE	246	10	113	2
2-36-1-L	PASSAGE	246	10	56	2
2-39-1-L	PASSAGE	246	10	16	4
2-48-1-L	PASSAGE	246	10	101	28
2-53-1-L	VESTIBULE	246	10	81	36
2-57-0-L	PASSAGE	246	10	2978	17
1-12-1A-L	PASSAGE	246	10	186	2
1-12-1B-L	PASSAGE	246	10	0	0
1-15-1-L	COMPANIONWAY	246	10	36	1
1-21-1-L	VESTIBULE	246	10	44	1
1-21-3-L	COMPANIONWAY	246	10	36	1
1-57-2-L	PASSAGE	246	10	280	2
1-59-2-L	COMPANIONWAY	246	10	2628	57
1-66-2-L	COMPANIONWAY	246	10	2196	57
1-82-0-L	PASSAGE	246	10	1092	8
1-84-2-L	COMPANIONWAY	246	10	2628	57
1-92-0-L	PASSAGE	246	10	3516	16
01-60-0A-L	PASSAGE	246	10	696	30
01-60-0B-L	PASSAGE	246	10	616	5
01-60-0C-L	PASSAGE	246	10	3096	28
01-66-2-L	PASSAGE	246	10	2880	30
01-79-0A-L	PASSAGE	246	10	1051	8
01-79-0B-L	PASSAGE	246	10	756	7
01-92-0-L	COMPANIONWAY	246	10	2628	51
02-57-0A-L	PASSAGE	246	10	358	8
02-57-0B-L	PASSAGE	246	10	252	9
02-57-0C-L	PASSAGE	246	10	540	5
02-59-2-L	COMPANIONWAY	246	10	2628	51
02-61-2-L	COMPANIONWAY	246	10	2628	51
CUI=LW	(Sanitary Spaces)				
1-57-0-L	DECK WR & WC	517	9	52	2
1-57-4-Q	CHANGE ROOM	588	8	76	3
1-60-1-L	GALLEY WR & WC	517	9	152	5
1-82-1-L	CREW WR, WC & SH	517	9	484	10

Table D.1 Ventilation Openings: Area and Average Height

Plan ID	Compartment Name	Preliminary Baseline		Ship Visit	
		Total Area (In2)	Avg.Height (In.)	Total Area (In2)	Avg.Height (In.)
1-82-3-L	CREW WR, WC & SH	517	9	484	10
1-82-4-L	CREW WR, WC & SH	517	9	484	10
1-96-1-L	CREW WR, WC & SH	517	9	484	10
1-97-4-L	CREW WR, WC & SH	517	9	484	10
1-98-1-L	CREW WR, WC & SH	517	9	484	10
01-57-4-L	CPO WR, WC, SH	517	9	513	8
01-71-2-L	CPO WR, WC, SH	517	9	268	7
01-74-1-L	MEDICAL TREATMENT WR, WC & SH	517	9	277	40
01-84-2-L	CREW WR, WC & SH	517	9	513	8
01-88-1-L	CREW WR, WC & SH	517	9	520	8
02-57-2-L	XO WR, WC, SH	517	9	232	11
02-63-1-L	CO WR, WC, SH	517	9	288	40
02-66-1-L	OFFICER WR, WC, SH	517	9	268	7
02-66-2-L	OFFICER WR, WC, SH	517	9	268	7
02-66-4-L	OFFICER WR, WC, SH	517	9	268	7
03-66-0-L	DECK WR & WC	517	9	52	2
CUI=QA	(Aux Machinery Spaces)				
4-82-0-E	AUXILIARY MACHINERY ROOM	748	240	1108	244
2-21-2-Q	POTABLE WATER PUMP ROOM	61	108	252	40
2-48-2-E	SOR PUMP ROOM	61	108	61	108
2-49-0-E	SOR MACHINERY ROOM	61	108	181	5
2-57-4-E	WATER SUPPLY EQPT ROOM	307	71	142	39
1-18-1-Q	D.C. REPAIR LKR NO. 1	61	108	0	0
1-18-2-Q	AFFF STA.	246	10	0	0
1-74-2-Q	DC REPAIR LKR NO. 2	36	96	36	1
1-85-2-Q	AFFF STA.	61	108	0	0
CUI=QE	(Emergency Aux Generator Spaces)				
01-78-1-F	EMERGENCY GEN SERVICE TK	0	0	0	0
01-78-3-E	EMERGENCY GENERATOR ROOM	226	13	2652	19
CUI=QF	(Fan Room)				
1-97-2-Q	FAN ROOM	192	4	36	1
02-73-0-Q	FAN ROOM	192	4	36	1
CUI=QG	(Galley/Pantry/Scullery)				
1-57-1-Q	GALLEY	486	20	1421	68
1-66-1-Q	GALLEY ANNEX	486	20	6390	49
1-66-3-Q	SCULLERY	96	4	545	34
01-57-0-Q	WARD ROOM PANTRY	486	20	308	76
02-85-0-Q	INCINERATOR ROOM	246	10	130	8
CUI=QL	(Laundry)				
1-105-2-Q	LAUNDRY	540	9	97	4
CUI=QO	(Office Spaces)				
1-71-2-Q	ENG LOG OFFICE & DC CENTRAL	342	7	152	76
01-68-0-Q	SHIP OFFICE	342	7	368	55
CUI=QS	(Shops)				
2-57-1-Q	MACHINE SHOP	307	71	133	4
2-59-1-Q	ELEC/ELEX WORKSHOP & STORERM	307	71	109	4
1-12-3-Q	BOATSWAIN SHOP	307	71	85	3
1-21-2-Q	ATON SHOP	540	9	74	6
CUI=TH	(Trunks/Hoists/Dumbwaiters)				
3-23-0-Q	CRANE PEDESTAL	246	10	10	1
1-19-2-T	ESC TRUNK	10	1	10	1
1-57-3-Q	DUMBWAITER TRUNK	10	1	10	1
1-80-1-E	VENT PLENUM	10	1	10	1

Table D.1 Ventilation Openings: Area and Average Height

Plan ID	Compartment Name	Preliminary Baseline		Ship Visit	
		Total Area (In2)	Avg.Height (In.)	Total Area (In2)	Avg.Height (In.)
1-80-1-Q	VENT PLENUM	10	1	10	1
CUI=TU	(Stacks/Engine Uptakes)				
1-76-0-Q	MMR (UPTAKE)	1296	48	1296	48
03-76-0-Q	STACK	1296	48	1296	48
CUI=V	(Voids/Cofferdams)				
4-17-2-V	VOID	0	0	0	0
4-37-2-V	VOID	0	0	0	0
4-39-0-V	VOID	0	0	0	0
4-39-0A-V	VOID	0	0	0	0
4-39-0C-V	VOID	0	0	0	0
3-51-0-V	VOID	0	0	0	0
2-39-0-V	COFFERDAM	0	0	0	0
2-39-2-V	VOID	0	0	0	0
2-48-0-V	COFFERDAM	0	0	0	0
CUI=W	(Water Tank (empty))				
4-21-0A-W	SW BALLAST TANK	0	0	0	0
4-21-0B-W	SW BALLAST TANK	0	0	0	0
4-21-0C-W	SW BALLAST TANK	0	0	0	0
4-30-3-W	SW BALLAST TANK	0	0	0	0
4-30-4-W	SW BALLAST TANK	0	0	0	0
4-48-0A-W	SW BALLAST TANK	0	0	0	0
4-48-0B-W	SW BALLAST TANK	0	0	0	0
4-48-0C-W	SW BALLAST TANK	0	0	0	0
4-57-0A-W	SW BALLAST TANK	0	0	0	0
4-57-0B-W	SW BALLAST TANK	0	0	0	0
4-57-0C-W	SW BALLAST TANK	0	0	0	0
4-80-0-W	SEA BAY	0	0	0	0
4-0-0-W	SW BALLAST TANK	0	0	0	0
4-6-0A-W	SW BALLAST TANK	0	0	0	0
4-6-0B-W	SW BALLAST TANK	0	0	0	0
4-6-0C-W	SW BALLAST TANK	0	0	0	0
2-25-1-WW	POTABLE WATER (CARGO)	0	0	0	0
2-25-2-W	POTABLE WATER (SHIP)	0	0	0	0

Table D.2 Barrier Data

Ship Visit Barrier Materials			Plan ID	Compartment Name Adjacent Compartment	Preliminary Baseline Barrier Materials		
<1>	<2>	<3>			<1>	<2>	<3>
			4-12-0-E	BOWTHRUSTER MCHRY ROOM	(CUI = EM)		
S3U	S3U	S3U	4-17-1-F	FUEL TANK	S3U	S3U	S3U
S3U	S3U	S3I	4-17-1-F	FUEL TANK	S3I	S3U	S3U
S3U	S3U	S3U	4-17-2-V	VOID	S3U	S3U	S3U
S3U	S3U	S3I	4-17-2-V	VOID	S3I	S3U	S3U
S3U	S3U	S3U	4-17-4-F	FUEL TANK	S3U	S3U	S3U
S3U	S3U	S3I	4-17-4-F	FUEL TANK	S3I	S3U	S3U
S3I	S3U	S3U	4-6-0A-W	SW BALLAST TANK	S3I	S3U	S3U
S3I	S3U	S3U	4-6-0A-W	SW BALLAST TANK	S3I	S3U	S3U
S3I	S3U	S3U	4-6-0B-W	SW BALLAST TANK	S3I	S3U	S3U
S3I	S3U	S3U	4-6-0C-W	SW BALLAST TANK	S3I	S3U	S3U
S3I	S3U	S3U	4-6-0C-W	SW BALLAST TANK	S3I	S3U	S3U
S3I	S3U	S3U	2-10-0-F	HYD OIL STG TANK	S3I	S3U	S3U
S3U		S3U	2-13-1-F	HPU RESERVOIR	S3U		S3U
S3U		S3U	2-13-1-F	HPU RESERVOIR	S3U		S3U
S3U		S3U	2-13-1-F	HPU RESERVOIR	S3U		S3U
S3U		S3U	2-13-1-F	HPU RESERVOIR	S3U		S3U
S3U		S3U	2-13-2-F	HPU RESERVOIR	S3U		S3U
S3U		S3U	2-13-2-F	HPU RESERVOIR	S3U		S3U
S3U		S3U	2-13-2-F	HPU RESERVOIR	S3U		S3U
S3U		S3U	2-13-2-F	HPU RESERVOIR	S3U		S3U
S3U	S3U	S3U	2-21-0-L	PASSAGE	S3U	S3U	S3U
S3U	S3U	S3U	2-21-1-A	SUPPLY DEPT STOREROO	S3U	S3U	S3U
S3U	S3U	S3U	2-21-2-Q	POTABLE WATER PUMP R	S3U	S3U	S3U
S2I	S5U		(none)	(weather bulkhead)	S2I	S5U	
S2I	S5U		(none)	(weather bulkhead)	S2I	S5U	
S2I	S5U		(none)	(weather bulkhead)	S2I	S5U	
S2U	S5U		(none)	(weather bulkhead)	S2U	S5U	
S2I	S5U		(none)	(weather bulkhead)	S2I	S5U	
S2I	S5U		(none)	(weather bulkhead)	S2I	S5U	
S2I	S5U		(none)	(weather bulkhead)	S2I	S5U	
S4U			4-17-1-F	FUEL TANK	S4U		
S4U			4-17-2-V	VOID	S4U		
S4U			4-17-4-F	FUEL TANK	S4U		
S4U			2-13-1-F	HPU RESERVOIR	S4U		
S4U			2-13-2-F	HPU RESERVOIR	S4U		
S4U			1-12-1A-L	PASSAGE	S4U		
S4U			1-12-2-M	ARMORY	S4U		
S4U			1-12-3-Q	BOATSWAIN SHOP	S4U		
S4U			1-15-1-L	COMPANIONWAY	S4U		
S4U			1-18-1-Q	D.C. REPAIR LKR NO.	S4U		
S4U			1-18-2-Q	AFFF STA.	S4U		
S4U			1-18-4-A	ATON STRM	S4U		
S4U			1-19-2-T	ESC TRUNK	S4U		
			4-17-2-V	VOID	(CUI = V)		
S3U	S3U	S3U	4-12-0-E	BOWTHRUSTER MCHRY RO	S3U	S3U	S3U

Table D.2 Barrier Data

Ship Visit Barrier Materials			Plan ID	Compartment Name Adjacent Compartment	Preliminary Baseline Barrier Materials		
<1>	<2>	<3>			<1>	<2>	<3>
S3I	S3U	S3U	4-12-0-E	BOWTHRUSTER MCHRY RO	S3U	S3U	S3I
S3U		S3U	4-17-1-F	FUEL TANK	S3U		S3U
S3U		S3U	4-17-1-F	FUEL TANK	S3U		S3U
S3U		S3U	4-17-4-F	FUEL TANK	S3U		S3U
S3U		S3U	4-17-4-F	FUEL TANK	S3U		S3U
S3U	S3U	S3U	4-21-0B-W	SW BALLAST TANK	S3U	S3U	S3U
S3I	S3U	S3U	3-21-0-L	PASSAGE	S3U	S3U	S3I
S4U			4-12-0-E	BOWTHRUSTER MCHRY RO	S4U		
			4-21-0A-W	SW BALLAST TANK	(CUI = W)		
S3U	S3U	S3U	4-17-4-F	FUEL TANK	S3U	S3U	S3U
S3U	S3U	S3U	4-17-4-F	FUEL TANK	S3U	S3U	S3U
000		000	4-21-0B-W	SW BALLAST TANK	000		000
000		000	4-21-0B-W	SW BALLAST TANK	000		000
S3U	S3U	S3U	4-30-2-F	FUEL TANK	S3U	S3U	S3U
S3U	S3U	S3U	4-30-2-F	FUEL TANK	S3U	S3U	S3U
S3U	S3U	S3U	4-30-4-W	SW BALLAST TANK	S3U	S3U	S3U
S3U	S3U	S3U	4-30-4-W	SW BALLAST TANK	S3U	S3U	S3U
S3U		S3I	3-21-0-L	PASSAGE	S3U		S3I
S3I		S3U	3-25-2-M	MAGAZINE NO. 2	S3U		S3I
S2U	S5U		(none)	(weather bulkhead)	S2U	S5U	
S2U	S5U		(none)	(weather bulkhead)	S2U	S5U	
S4U			2-21-2-Q	POTABLE WATER PUMP R	S4U		
			4-21-0B-W	SW BALLAST TANK	(CUI = W)		
S3U	S3U	S3U	4-17-1-F	FUEL TANK	S3U	S3U	S3U
S3U	S3U	S3U	4-17-2-V	VOID	S3U	S3U	S3U
S3U	S3U	S3U	4-17-4-F	FUEL TANK	S3U	S3U	S3U
000		000	4-21-0A-W	SW BALLAST TANK	000		000
000		000	4-21-0A-W	SW BALLAST TANK	000		000
000		000	4-21-0C-W	SW BALLAST TANK	000		000
000		000	4-21-0C-W	SW BALLAST TANK	000		000
S3U	S3U	S3U	4-30-0-F	FUEL TANK	S3U	S3U	S3U
S4U			3-21-0-L	PASSAGE	S4U		
S4I			3-23-0-Q	CRANE PEDESTAL	S4I		
S4U			3-25-1-M	MAGAZINE NO. 1	S4U		
S4U			3-25-2-M	MAGAZINE NO. 2	S4U		
			4-21-0C-W	SW BALLAST TANK	(CUI = W)		
S3U	S3U	S3U	4-17-1-F	FUEL TANK	S3U	S3U	S3U
S3U	S3U	S3U	4-17-1-F	FUEL TANK	S3U	S3U	S3U
000		000	4-21-0B-W	SW BALLAST TANK	000		000
000		000	4-21-0B-W	SW BALLAST TANK	000		000
S3U	S3U	S3U	4-30-1-F	FUEL TANK	S3U	S3U	S3U
S3U	S3U	S3U	4-30-1-F	FUEL TANK	S3U	S3U	S3U
S3U	S3U	S3U	4-30-3-W	SW BALLAST TANK	S3U	S3U	S3U
S3U	S3U	S3U	4-30-3-W	SW BALLAST TANK	S3U	S3U	S3U
S3U		S3I	3-21-0-L	PASSAGE	S3U		S3I
S3I		S3U	3-25-1-M	MAGAZINE NO. 1	S3U		S3I

Table D.2 Barrier Data

Ship Visit Barrier Materials			Plan ID	Compartment Name	Preliminary Baseline Barrier Materials		
<1>	<2>	<3>			Adjacent Compartment	<1>	<2>
S2U	S5U		(none)	(weather bulkhead)	S2U	S5U	
S2U	S5U		(none)	(weather bulkhead)	S2U	S5U	
S4U			2-21-0-L	PASSAGE	S4U		
S4U			2-21-1-A	SUPPLY DEPT STOREROO	S4U		
			4-30-3-W	SW BALLAST TANK	(CUI = W)		
S3U	S3U	S3U	4-21-0C-W	SW BALLAST TANK	S3U	S3U	S3U
S3U	S3U	S3U	4-21-0C-W	SW BALLAST TANK	S3U	S3U	S3U
S3U		S3U	4-30-1-F	FUEL TANK	S3U		S3U
S3U		S3U	4-30-1-F	FUEL TANK	S3U		S3U
S3U	S3U	S3U	4-39-0C-V	VOID	S3U	S3U	S3U
S3U	S5U		(none)	(weather bulkhead)	S3U	S5U	
S2U	S5U		(none)	(weather bulkhead)	S2U	S5U	
S2U	S5U		(none)	(weather bulkhead)	S2U	S5U	
S4U			2-30-0-AA	CARGO HOLD	S4U		
S4U			2-36-1-L	PASSAGE	S4U		
			4-30-4-W	SW BALLAST TANK	(CUI = W)		
S3U	S3U	S3U	4-21-0A-W	SW BALLAST TANK	S3U	S3U	S3U
S3U	S3U	S3U	4-21-0A-W	SW BALLAST TANK	S3U	S3U	S3U
S3U		S3U	4-30-2-F	FUEL TANK	S3U		S3U
S3U		S3U	4-30-2-F	FUEL TANK	S3U		S3U
S3U	S3U	S3U	4-39-0A-V	VOID	S3U	S3U	S3U
S3U	S5U		(none)	(weather bulkhead)	S3U	S5U	
S2U	S5U		(none)	(weather bulkhead)	S2U	S5U	
S3U	S5U		(none)	(weather bulkhead)	S3U	S5U	
S4U			2-30-0-AA	CARGO HOLD	S4U		
			4-37-2-V	VOID	(CUI = V)		
S3U		S3U	4-30-0-F	FUEL TANK	S3U		S3U
S3U		S3U	4-30-0-F	FUEL TANK	S3U		S3U
S3U		S3U	4-30-0-F	FUEL TANK	S3U		S3U
S3U		S3U	4-30-0-F	FUEL TANK	S3U		S3U
S3U		S3U	4-30-0-F	FUEL TANK	S3U		S3U
S3U		S3U	4-30-0-F	FUEL TANK	S3U		S3U
S3U	S3U	S3U	4-39-0-V	VOID	S3U	S3U	S3U
S3U	S3U	S3U	3-39-0-FF	SOR TANK	S3U	S3U	S3U
S4U			2-30-0-AA	CARGO HOLD	S4U		
			4-39-0-V	VOID	(CUI = V)		
S3U	S3U	S3U	4-30-0-F	FUEL TANK	S3U	S3U	S3U
S3U	S3U	S3U	4-30-0-F	FUEL TANK	S3U	S3U	S3U
S3U	S3U	S3U	4-30-1-F	FUEL TANK	S3U	S3U	S3U
S3U	S3U	S3U	4-30-2-F	FUEL TANK	S3U	S3U	S3U
S3U	S3U	S3U	4-37-2-V	VOID	S3U	S3U	S3U
S3U	S3U	S3U	4-48-0A-W	SW BALLAST TANK	S3U	S3U	S3U
S3U	S3U	S2I	4-48-0B-W	SW BALLAST TANK	S2I	S3U	S3U
S3U	S3U	S3U	4-48-0C-W	SW BALLAST TANK	S3U	S3U	S3U
S2U	S5U		(none)	(weather bulkhead)	S2U	S5U	
S2U	S5U		(none)	(weather bulkhead)	S2U	S5U	

Table D.2 Barrier Data

Ship Visit Barrier Materials			Plan ID	Compartment Name	Preliminary Baseline Barrier Materials		
<1>	<2>	<3>			Adjacent Compartment	<1>	<2>
S4U			3-39-0-FF	SOR TANK	S4U		
S4U			4-39-0A-V	VOID	S4U		
S4U			4-39-0C-V	VOID	S4U		
			4-48-0A-W	SW BALLAST TANK	(CUI = W)		
S3U	S3U	S3U	4-39-0-V	VOID	S3U	S3U	S3U
000		000	4-48-0B-W	SW BALLAST TANK	000		000
S3U	S3U	S3U	4-57-0A-W	SW BALLAST TANK	S3U	S3U	S3U
S3U	S3U	S3U	4-57-0A-W	SW BALLAST TANK	S3U	S3U	S3U
S3U	S3U	S3U	4-39-0A-V	VOID	S3U	S3U	S3U
S3U		S3U	3-48-2-F	FUEL TANK	S3U		S3U
S2U	S5U		(none)	(weather bulkhead)	S2U	S5U	
S2U	S5U		(none)	(weather bulkhead)	S2U	S5U	
S3U	S5U		(none)	(weather bulkhead)	S3U	S5U	
S3U	S5U		(none)	(weather bulkhead)	S3U	S5U	
S4U			2-48-2-E	SOR PUMP ROOM	S4U		
			4-48-0B-W	SW BALLAST TANK	(CUI = W)		
S2I	S3U	S3U	4-39-0-V	VOID	S3U	S3U	S2I
000		000	4-48-0A-W	SW BALLAST TANK	000		000
000		000	4-48-0C-W	SW BALLAST TANK	000		000
S3U	S3U	S3U	4-57-0A-W	SW BALLAST TANK	S3U	S3U	S3U
S3U	S3U	S3U	4-57-0B-W	SW BALLAST TANK	S3U	S3U	S3U
S3U	S3U	S3U	4-57-0C-W	SW BALLAST TANK	S3U	S3U	S3U
S4U			3-48-0-FF	CARGO FUEL TANK	S4U		
S4U			3-48-1-F	FUEL TANK	S4U		
S4U			3-48-2-F	FUEL TANK	S4U		
S4U			3-51-0-V	VOID	S4U		
S4U			3-54-0-F	FUEL OIL OVFL TANK	S4U		
			4-48-0C-W	SW BALLAST TANK	(CUI = W)		
S3U	S3U	S3U	4-39-0-V	VOID	S3U	S3U	S3U
000		000	4-48-0B-W	SW BALLAST TANK	000		000
S3U	S3U	S3U	4-57-0C-W	SW BALLAST TANK	S3U	S3U	S3U
S3U	S3U	S3U	4-57-0C-W	SW BALLAST TANK	S3U	S3U	S3U
S3U	S3U	S3U	4-39-0C-V	VOID	S3U	S3U	S3U
S3U		S3U	3-48-1-F	FUEL TANK	S3U		S3U
S2U	S5U		(none)	(weather bulkhead)	S2U	S5U	
S3U	S5U		(none)	(weather bulkhead)	S3U	S5U	
S3U	S5U		(none)	(weather bulkhead)	S3U	S5U	
S3U	S5U		(none)	(weather bulkhead)	S3U	S5U	
S4U			2-48-1-L	PASSAGE	S4U		
S4U			2-50-1-A	ENGINEER STOREROOM	S4U		
			4-57-0A-W	SW BALLAST TANK	(CUI = W)		
S3U	S3U	S3U	4-48-0A-W	SW BALLAST TANK	S3U	S3U	S3U
S3U	S3U	S3U	4-48-0A-W	SW BALLAST TANK	S3U	S3U	S3U
S3U	S3U	S3U	4-48-0B-W	SW BALLAST TANK	S3U	S3U	S3U
S3U		S3U	4-57-0B-W	SW BALLAST TANK	S3U		S3U
S3U		S3U	4-60-2-F	OILY WATER TANK	S3U		S3U

Table D.2 Barrier Data

Ship Visit Barrier Materials			Plan ID	Compartment Name	Preliminary Baseline Barrier Materials		
<1>	<2>	<3>			Adjacent Compartment	<1>	<2>
S3I	S3U	S3U	4-66-0-E	MAIN MACHINERY ROOM	S3U	S3U	S3I
S3I	S3U	S3U	4-66-0-E	MAIN MACHINERY ROOM	S3U	S3U	S3I
S3U	S3U	S3U	3-48-2-F	FUEL TANK	S3U	S3U	S3U
S3U		S3U	3-57-0-A	SUPPLY DEPT. STORERO	S3U		S3I
S3U		S3U	3-62-2-F	FUEL SERVICE TANK	S3U		S3U
S3U		S3U	3-62-2-F	FUEL SERVICE TANK	S3U		S3U
S2U	S5U		(none)	(weather bulkhead)	S2U	S5U	
S2U	S5U		(none)	(weather bulkhead)	S2U	S5U	
S3I	S5U		(none)	(weather bulkhead)	S3I	S5U	
S4U			3-62-2-F	FUEL SERVICE TANK	S4U		
S4U			2-57-2-A	SHIP STORE	S4U		
S4U			2-57-4-E	WATER SUPPLY EQPT RO	S4U		
			4-57-0B-W	SW BALLAST TANK	(CUI = W)		
S3U	S3U	S3U	4-48-0B-W	SW BALLAST TANK	S3U	S3U	S3U
S3U		S3U	4-57-0A-W	SW BALLAST TANK	S3U		S3U
S3U		S3U	4-57-0C-W	SW BALLAST TANK	S3U		S3U
S3U		S3U	4-60-1-F	LO DRAIN TANK	S3U		S3U
S3U		S3U	4-60-2-F	OILY WATER TANK	S3U		S3U
S4U			3-57-0-A	SUPPLY DEPT. STORERO	S4U		
			4-57-0C-W	SW BALLAST TANK	(CUI = W)		
S3U	S3U	S3U	4-48-0B-W	SW BALLAST TANK	S3U	S3U	S3U
S3U	S3U	S3U	4-48-0C-W	SW BALLAST TANK	S3U	S3U	S3U
S3U	S3U	S3U	4-48-0C-W	SW BALLAST TANK	S3U	S3U	S3U
S3U		S3U	4-57-0B-W	SW BALLAST TANK	S3U		S3U
S3U		S3U	4-60-1-F	LO DRAIN TANK	S3U		S3U
S3I	S3U	S3U	4-66-0-E	MAIN MACHINERY ROOM	S3U	S3U	S3I
S3I	S3U	S3U	4-66-0-E	MAIN MACHINERY ROOM	S3U	S3U	S3I
S3U	S3U	S3U	3-48-1-F	FUEL TANK	S3U	S3U	S3U
S3U		S3U	3-57-0-A	SUPPLY DEPT. STORERO	S3U		S3I
S3U		S3U	3-61-1-F	FUEL SERVICE TANK	S3U		S3U
S3U		S3U	3-61-1-F	FUEL SERVICE TANK	S3U		S3U
S2U	S5U		(none)	(weather bulkhead)	S2U	S5U	
S2U	S5U		(none)	(weather bulkhead)	S2U	S5U	
S3I	S5U		(none)	(weather bulkhead)	S3I	S5U	
S4U			3-61-1-F	FUEL SERVICE TANK	S4U		
S4U			2-57-0-L	PASSAGE	S4U		
S4U			2-57-1-Q	MACHINE SHOP	S4U		
S4U			2-59-1-Q	ELEC/ELEX WORKSHOP &	S4U		
			4-66-0-E	MAIN MACHINERY ROOM	(CUI = EM)		
S3U	S3U	S3I	4-57-0A-W	SW BALLAST TANK	S3I	S3U	S3U
S3U	S3U	S3I	4-57-0A-W	SW BALLAST TANK	S3I	S3U	S3U
S3U	S3U	S3I	4-57-0C-W	SW BALLAST TANK	S3I	S3U	S3U
S3U	S3U	S3I	4-57-0C-W	SW BALLAST TANK	S3I	S3U	S3U
S3U	S3U	S3I	4-60-1-F	LO DRAIN TANK	S3I	S3U	S3U
S3U	S3U	S3I	4-60-2-F	OILY WATER TANK	S3I	S3U	S3U
S2I		S2U	4-71-0-F	WASTE OIL TANK	S2U		S2U

Table D.2 Barrier Data

Ship Visit Barrier Materials			Plan ID	Compartment Name Adjacent Compartment	Preliminary Baseline Barrier Materials		
<1>	<2>	<3>			<1>	<2>	<3>
S2I		S2U	4-71-0-F	WASTE OIL TANK	S2U		S2U
S2I		S2U	4-71-0-F	WASTE OIL TANK	S2U		S2U
S2I		S2U	4-71-0-F	WASTE OIL TANK	S2U		S2U
S2U		S2I	4-80-0-W	SEA BAY	S2I		S2U
S2U		S2I	4-80-0-W	SEA BAY	S2I		S2U
S2U		S2I	4-80-0-W	SEA BAY	S2I		S2U
S2U		S2I	4-80-0-W	SEA BAY	S2I		S2U
S2U		S2I	4-80-0-W	SEA BAY	S2I		S2U
S2U		S2I	4-80-0-W	SEA BAY	S2I		S2U
S2U		S2I	4-80-0-W	SEA BAY	S2I		S2U
S3I	S3U	S3I	4-82-0-E	AUXILIARY MACHINERY	S3U	S3U	S3U
S3I	S3U	S3I	4-82-0-E	AUXILIARY MACHINERY	S3U	S3U	S3U
S3I	S3U	S3I	4-82-0-E	AUXILIARY MACHINERY	S3U	S3U	S3U
S3I	S3U	S3I	4-82-0-E	AUXILIARY MACHINERY	S3U	S3U	S3U
S3I	S3U	S3U	3-57-0-A	SUPPLY DEPT. STORERO	S3I	S3U	S3U
S3I	S3U	S3U	3-61-1-F	FUEL SERVICE TANK	S3I	S3U	S3U
S3I	S3U	S3U	3-62-2-F	FUEL SERVICE TANK	S3I	S3U	S3U
S3I	S3U	S3I	2-57-0-L	PASSAGE	S3U	S3U	S3U
S3I	S3U	S3U	2-57-1-Q	MACHINE SHOP	S3U	S3U	S3U
S3I	S3U	S3U	2-57-4-E	WATER SUPPLY EQPT RO	S3U	S3U	S3U
S3I	S3U	S3I	2-59-1-Q	ELEC/ELEX WORKSHOP &	S3U	S3U	S3U
S3I		S3U	2-89-1-C	ENGINEERING CONTROL	S3U		S3I
S3I		S3U	2-89-1-C	ENGINEERING CONTROL	S3U		S3I
S2I	S5U		(none)	(weather bulkhead)	S2I	S5U	
S2I	S5U		(none)	(weather bulkhead)	S2I	S5U	
S2I	S5U		(none)	(weather bulkhead)	S2I	S5U	
S2I	S5U		(none)	(weather bulkhead)	S2I	S5U	
S2I	S5U		(none)	(weather bulkhead)	S2I	S5U	
S2I	S5U		(none)	(weather bulkhead)	S2I	S5U	
S2I	S5U		(none)	(weather bulkhead)	S2I	S5U	
S2I	S5U		(none)	(weather bulkhead)	S2I	S5U	
S2I	S5U		(none)	(weather bulkhead)	S2I	S5U	
S2I	S5U		(none)	(weather bulkhead)	S2I	S5U	
S2I	S5U		(none)	(weather bulkhead)	S2I	S5U	
S4U			4-71-0-F	WASTE OIL TANK	S4U		
S4U			4-80-0-W	SEA BAY	S4U		
S4U			2-89-1-C	ENGINEERING CONTROL	S4U		
S4I			1-60-6A-A	DRY PROVISION STORER	S4I		
S4I			1-66-0-L	CREW MESS	S4I		
S4I			1-66-1-Q	GALLEY ANNEX	S4I		
S4I			1-66-2-L	COMPANIONWAY	S4I		
S4I			1-66-3-Q	SCULLERY	S4I		
S4I			1-71-2-Q	ENG LOG OFFICE & DC	S4I		
S4I			1-74-2-Q	DC REPAIR LKR NO. 2	S4I		
000			1-76-0-Q	MMR (UPTAKE)	000		
S4I			1-77-1-A	CREW LOCKER	S4I		

Table D.2 Barrier Data

Ship Visit Barrier Materials			Plan ID	Compartment Name	Preliminary Baseline Barrier Materials		
<1>	<2>	<3>			Adjacent Compartment	<1>	<2>
S4I			1-77-2-L	CPO MESS & LOUNGE	S4I		
S4I			1-77-3-L	CREW LOUNGE	S4I		
S4I			1-80-1-E	VENT PLENUM	S4I		
			4-80-0-W	SEA BAY	(CUI = W)		
S2I		S2U	4-66-0-E	MAIN MACHINERY ROOM	S2U		S2I
S2I		S2U	4-66-0-E	MAIN MACHINERY ROOM	S2U		S2I
S2I		S2U	4-66-0-E	MAIN MACHINERY ROOM	S2U		S2I
S2I		S2U	4-66-0-E	MAIN MACHINERY ROOM	S2U		S2I
S2I		S2U	4-66-0-E	MAIN MACHINERY ROOM	S2U		S2I
S2I		S2U	4-66-0-E	MAIN MACHINERY ROOM	S2U		S2I
S2I		S2U	4-66-0-E	MAIN MACHINERY ROOM	S2U		S2I
S2I	S2I	S2U	4-82-0-E	AUXILIARY MACHINERY	S2U	S2I	S2I
S4U			4-66-0-E	MAIN MACHINERY ROOM	S4U		
			4-82-0-E	AUXILIARY MACHINERY ROOM	(CUI = QA)		
S3I	S3U	S3I	4-66-0-E	MAIN MACHINERY ROOM	S3U	S3U	S3U
S3I	S3U	S3I	4-66-0-E	MAIN MACHINERY ROOM	S3U	S3U	S3U
S3I	S3U	S3I	4-66-0-E	MAIN MACHINERY ROOM	S3U	S3U	S3U
S3I	S3U	S3I	4-66-0-E	MAIN MACHINERY ROOM	S3U	S3U	S3U
S2U	S2I	S2I	4-80-0-W	SEA BAY	S2I	S2I	S2U
S3I	S3U	S3U	4-92-0-E	STERN THRUSTER MACHR	S3U	S3U	S3U
S3I	S3U	S3U	4-92-0-E	STERN THRUSTER MACHR	S3U	S3U	S3U
S3I	S3U	S3U	4-92-0-E	STERN THRUSTER MACHR	S3U	S3U	S3U
S3I	S3U	S3U	2-89-1-C	ENGINEERING CONTROL	S3U	S3U	S3I
S3U		S3U	1-76-0-Q	MMR (UPTAKE)	S3U		S3U
S3U		S3U	1-82-0-L	PASSAGE	S3U		S3U
S3U		S3I	1-82-1-L	CREW WR, WC & SH	S3U		S3I
S3I		S3U	1-85-1-L	CREW SR	S3U		S3I
S2U		S2U	1-85-2-Q	AFFF STA.	S2U		S2U
S2I	S5U		(none)	(weather bulkhead)	S2I	S5U	
S2I	S5U		(none)	(weather bulkhead)	S2I	S5U	
S2I	S5U		(none)	(weather bulkhead)	S2I	S5U	
S2I	S5U		(none)	(weather bulkhead)	S2I	S5U	
S2I	S5U		(none)	(weather bulkhead)	S2I	S5U	
S2I	S5U		(none)	(weather bulkhead)	S2I	S5U	
S2I	S5U		(none)	(weather bulkhead)	S2I	S5U	
S2I	S5U		(none)	(weather bulkhead)	S2I	S5U	
S2I	S5U		(none)	(weather bulkhead)	S2I	S5U	
S2I	S5U		(none)	(weather bulkhead)	S2I	S5U	
S4U			1-76-0-Q	MMR (UPTAKE)	S4U		
S4I			1-82-0-L	PASSAGE	S4I		
S4I			1-82-1-L	CREW WR, WC & SH	S4I		
S4I			1-82-2-Q	C.G. LKR W/ SINK	S4I		
S4I			1-82-3-L	CREW WR, WC & SH	S4I		
S4I			1-82-4-L	CREW WR, WC & SH	S4I		
S4I			1-84-2-L	COMPANIONWAY	S4I		
S4I			1-85-1-L	CREW SR	S4I		

Table D.2 Barrier Data

Ship Visit Barrier Materials			Plan ID	Compartment Name Adjacent Compartment	Preliminary Baseline Barrier Materials		
<1>	<2>	<3>			<1>	<2>	<3>
S4I			1-85-2-Q	AFFF STA.	S4I		
S4I			1-85-3-L	CREW SR	S4I		
S4I			1-85-4-L	CREW SR	S4I		
			4-92-0-E	STERN THRUSTER MACHRY ROOM	(CUI = EM)		
S3U	S3U	S3I	4-82-0-E	AUXILIARY MACHINERY	S3U	S3U	S3U
S3U	S3U	S3I	4-82-0-E	AUXILIARY MACHINERY	S3U	S3U	S3U
S3U	S3U	S3I	4-82-0-E	AUXILIARY MACHINERY	S3U	S3U	S3U
S2I	S5U		(none)	(weather bulkhead)	S2I	S5U	
S2I	S5U		(none)	(weather bulkhead)	S2I	S5U	
S3I	S5U		(none)	(weather bulkhead)	S3I	S5U	
S2I	S5U		(none)	(weather bulkhead)	S2I	S5U	
S2I	S5U		(none)	(weather bulkhead)	S2I	S5U	
S3I	S5U		(none)	(weather bulkhead)	S3I	S5U	
S2I	S5U		(none)	(weather bulkhead)	S2I	S5U	
S2I	S5U		(none)	(weather bulkhead)	S2I	S5U	
S2I	S5U		(none)	(weather bulkhead)	S2I	S5U	
S2I	S5U		(none)	(weather bulkhead)	S2I	S5U	
S2I	S5U		(none)	(weather bulkhead)	S2I	S5U	
S2I	S5U		(none)	(weather bulkhead)	S2I	S5U	
S2I	S5U		(none)	(weather bulkhead)	S2I	S5U	
S2I	S5U		(none)	(weather bulkhead)	S2I	S5U	
S2I	S5U		(none)	(weather bulkhead)	S2I	S5U	
S2I	S5U		(none)	(weather bulkhead)	S2I	S5U	
S4I			1-92-0-L	PASSAGE	S4I		
S4I			1-92-1-L	CREW SR	S4I		
S4I			1-92-2-L	CREW SR	S4I		
S4I			1-96-0-L	CREW SR	S4I		
S4I			1-96-1-L	CREW WR, WC & SH	S4I		
			4-0-0-W	SW BALLAST TANK	(CUI = W)		
S3U	S3U	S3U	3-6-0-Q	CHAIN LOCKER SUMP	S3U	S3U	S3U
S3U	S3U	S3U	4-6-0A-W	SW BALLAST TANK	S3U	S3U	S3U
S3U	S3U	S3U	4-6-0A-W	SW BALLAST TANK	S3U	S3U	S3U
S3U	S3U	S3U	4-6-0C-W	SW BALLAST TANK	S3U	S3U	S3U
S3U	S3U	S3U	4-6-0C-W	SW BALLAST TANK	S3U	S3U	S3U
S3U	S3U	S3U	2-6-1-Q	CHAIN LOCKER	S3U	S3U	S3U
S3U	S3U	S3U	2-6-2-Q	CHAIN LOCKER	S3U	S3U	S3U
S2I	S5U		(none)	(weather bulkhead)	S2I	S5U	
S2I	S5U		(none)	(weather bulkhead)	S2I	S5U	
S2I	S5U		(none)	(weather bulkhead)	S2I	S5U	
S2I	S5U		(none)	(weather bulkhead)	S2I	S5U	
S2U	S5U		(none)	(weather bulkhead)	S2U	S5U	
S2U	S5U		(none)	(weather bulkhead)	S2U	S5U	
S2U	S5U		(none)	(weather bulkhead)	S2U	S5U	
S2U	S5U		(none)	(weather bulkhead)	S2U	S5U	
S2U	S5U		(none)	(weather bulkhead)	S2U	S5U	
S2U	S5U		(none)	(weather bulkhead)	S2U	S5U	

Table D.2 Barrier Data

Ship Visit Barrier Materials			Plan ID	Compartment Name	Preliminary Baseline Barrier Materials		
<1>	<2>	<3>			Adjacent Compartment	<1>	<2>
S2U	S5U		(none)	(weather bulkhead)	S2U	S5U	
S2U	S5U		(none)	(weather bulkhead)	S2U	S5U	
S4U			1-0-0-A	BOATSWAIN STOREROOM	S4U		
S4U			(none)	(weather overhead)	S4U		
			3-6-0-Q	CHAIN LOCKER SUMP	(CUI = AG)		
S3U	S3U	S3U	4-0-0-W	SW BALLAST TANK	S3U	S3U	S3U
S3U		S3I	4-6-0A-W	SW BALLAST TANK	S3I		S3U
S3U		S3I	4-6-0B-W	SW BALLAST TANK	S3I		S3U
S3U		S3I	4-6-0C-W	SW BALLAST TANK	S3I		S3U
S4U			2-6-1-Q	CHAIN LOCKER	S4U		
S4U			2-6-2-Q	CHAIN LOCKER	S4U		
			4-6-0A-W	SW BALLAST TANK	(CUI = W)		
S3U	S3U	S3I	4-12-0-E	BOWTHRUSTER MCHRY RO	S3U	S3U	S3I
S3U	S3U	S3I	4-12-0-E	BOWTHRUSTER MCHRY RO	S3U	S3U	S3I
S3U	S3U	S3U	4-0-0-W	SW BALLAST TANK	S3U	S3U	S3U
S3U	S3U	S3U	4-0-0-W	SW BALLAST TANK	S3U	S3U	S3U
S3I		S3U	3-6-0-Q	CHAIN LOCKER SUMP	S3U		S3I
000		000	4-6-0B-W	SW BALLAST TANK	000		000
S3U		S3U	2-6-2-Q	CHAIN LOCKER	S3U		S3U
S3U		S3U	2-10-0-F	HYD OIL STG TANK	S3U		S3U
S2U	S5U		(none)	(weather bulkhead)	S2U	S5U	
S2U	S5U		(none)	(weather bulkhead)	S2U	S5U	
S2I	S5U		(none)	(weather bulkhead)	S2I	S5U	
S4U			1-6-2-A	FLAM. LIQ. STOREROOM	S4U		
			4-6-0B-W	SW BALLAST TANK	(CUI = W)		
S3U	S3U	S3I	4-12-0-E	BOWTHRUSTER MCHRY RO	S3U	S3U	S3I
S3I		S3U	3-6-0-Q	CHAIN LOCKER SUMP	S3U		S3I
000		000	4-6-0A-W	SW BALLAST TANK	000		000
000		000	4-6-0C-W	SW BALLAST TANK	000		000
S4U			2-10-0-F	HYD OIL STG TANK	S4U		
			4-6-0C-W	SW BALLAST TANK	(CUI = W)		
S3U	S3U	S3I	4-12-0-E	BOWTHRUSTER MCHRY RO	S3U	S3U	S3I
S3U	S3U	S3I	4-12-0-E	BOWTHRUSTER MCHRY RO	S3U	S3U	S3I
S3U	S3U	S3U	4-0-0-W	SW BALLAST TANK	S3U	S3U	S3U
S3U	S3U	S3U	4-0-0-W	SW BALLAST TANK	S3U	S3U	S3U
S3I		S3U	3-6-0-Q	CHAIN LOCKER SUMP	S3U		S3I
000		000	4-6-0B-W	SW BALLAST TANK	000		000
S3U		S3U	2-6-1-Q	CHAIN LOCKER	S3U		S3U
S3U		S3U	2-10-0-F	HYD OIL STG TANK	S3U		S3U
S2U	S5U		(none)	(weather bulkhead)	S2U	S5U	
S2U	S5U		(none)	(weather bulkhead)	S2U	S5U	
S2I	S5U		(none)	(weather bulkhead)	S2I	S5U	
S4U			1-6-1-A	BOATSWAIN STOREROOM	S4U		
			3-21-0-L	PASSAGE	(CUI = LP)		
S3U	S3U	S3I	4-17-1-F	FUEL TANK	S3I	S3U	S3U
S3U	S3U	S3I	4-17-2-V	VOID	S3I	S3U	S3U

Table D.2 Barrier Data

Ship Visit Barrier Materials			Plan ID	Compartment Name Adjacent Compartment	Preliminary Baseline Barrier Materials		
<1>	<2>	<3>			<1>	<2>	<3>
S3U	S3U	S3I	4-17-4-F	FUEL TANK	S3I	S3U	S3U
S3I		S3U	4-21-0A-W	SW BALLAST TANK	S3I		S3U
S3I		S3U	4-21-0C-W	SW BALLAST TANK	S3I		S3U
S3U		S3U	3-23-0-Q	CRANE PEDESTAL	S3U		S3U
S3U		S3U	3-23-0-Q	CRANE PEDESTAL	S3U		S3U
S3U		S3U	3-23-0-Q	CRANE PEDESTAL	S3U		S3U
S3U		S3U	3-25-1-M	MAGAZINE NO. 1	S3U		S3U
S3U		S3U	3-25-2-M	MAGAZINE NO. 2	S3U		S3U
S4U			4-21-0B-W	SW BALLAST TANK	S4U		
S4U			2-21-0-L	PASSAGE	S4U		
S4U			2-21-2-Q	POTABLE WATER PUMP R	S4U		
			3-23-0-Q	CRANE PEDESTAL	(CUI = TH)		
S3U		S3U	3-21-0-L	PASSAGE	S3U		S3U
S3U		S3U	3-21-0-L	PASSAGE	S3U		S3U
S3U		S3U	3-21-0-L	PASSAGE	S3U		S3U
S3U		S3U	3-25-1-M	MAGAZINE NO. 1	S3U		S3U
S3U		S3U	3-25-1-M	MAGAZINE NO. 1	S3U		S3U
S3U		S3U	3-25-2-M	MAGAZINE NO. 2	S3U		S3U
S3U		S3U	3-25-2-M	MAGAZINE NO. 2	S3U		S3U
S3U		S3U	2-21-0-L	PASSAGE	S3U		S3U
S3U		S3U	2-21-0-L	PASSAGE	S3U		S3U
S3U		S3U	2-21-0-L	PASSAGE	S3U		S3U
S3U		S3I	2-25-1-WW	POTABLE WATER (CARGO	S3I		S3U
S3U		S3I	2-25-1-WW	POTABLE WATER (CARGO	S3I		S3U
S3U		S3I	2-25-2-W	POTABLE WATER (SHIP)	S3I		S3U
S3U		S3I	2-25-2-W	POTABLE WATER (SHIP)	S3I		S3U
S3U		S3I	1-21-1-L	VESTIBULE	S3U		S3U
S3U		S3I	1-21-1-L	VESTIBULE	S3U		S3U
S3U		S3I	1-21-2-Q	ATON SHOP	S3U		S3U
S3U		S3I	1-21-2-Q	ATON SHOP	S3U		S3U
S3I	S3U		(none)	(weather bulkhead)	S3I	S3U	
S3I	S3U		(none)	(weather bulkhead)	S3I	S3U	
S3I	S3U		(none)	(weather bulkhead)	S3I	S3U	
S4I			4-21-0B-W	SW BALLAST TANK	S4I		
S4U			01-27-0-C	BUOY DECK CONTROL BO	S4U		
S4U			(none)	(weather overhead)	S4U		
			4-39-0A-V	VOID	(CUI = V)		
S3U	S3U	S3U	4-30-4-W	SW BALLAST TANK	S3U	S3U	S3U
S3U	S3U	S3U	4-48-0A-W	SW BALLAST TANK	S3U	S3U	S3U
S3U		S3U	3-39-0-FF	SOR TANK	S3U		S3U
S2U	S5U		(none)	(weather bulkhead)	S2U	S5U	
S4U			4-39-0-V	VOID	S4U		
S4U			2-39-2-V	VOID	S4U		
			4-39-0C-V	VOID	(CUI = V)		
S3U	S3U	S3U	4-30-3-W	SW BALLAST TANK	S3U	S3U	S3U
S3U	S3U	S3U	4-48-0C-W	SW BALLAST TANK	S3U	S3U	S3U

Table D.2 Barrier Data

Ship Visit Barrier Materials			Plan ID	Compartment Name	Preliminary Baseline Barrier Materials		
<1>	<2>	<3>			Adjacent Compartment	<1>	<2>
S3U		S3U	3-39-0-FF	SOR TANK	S3U		S3U
S2U	S5U		(none)	(weather bulkhead)	S2U	S5U	
S4U			4-39-0-V	VOID	S4U		
S4U			2-39-1-L	PASSAGE	S4U		
			3-51-0-V	VOID	(CUI = V)		
S3U		S3U	3-48-0-FF	CARGO FUEL TANK	S3U		S3U
S3U		S3U	3-48-1-F	FUEL TANK	S3U		S3U
S3U		S3U	3-48-2-F	FUEL TANK	S3U		S3U
S3U		S3U	3-54-0-F	FUEL OIL OVFL TANK	S3U		S3U
S4U			4-48-0B-W	SW BALLAST TANK	S4U		
S4U			2-48-1-L	PASSAGE	S4U		
S4U			2-49-0-E	SOR MACHINERY ROOM	S4U		
S4U			2-53-1-L	VESTIBULE	S4U		
			3-57-0-A	SUPPLY DEPT. STOREROOM NO. 2	(CUI = AS)		
S3U		S3U	4-57-0A-W	SW BALLAST TANK	S3I		S3U
S3U		S3U	4-57-0C-W	SW BALLAST TANK	S3I		S3U
S3U	S3U	S3I	4-66-0-E	MAIN MACHINERY ROOM	S3U	S3U	S3I
S3U	S3U	S3I	3-54-0-F	FUEL OIL OVFL TANK	S3I	S3U	S3U
S3U		S3I	3-61-1-F	FUEL SERVICE TANK	S3I		S3U
S3U		S3I	3-62-2-F	FUEL SERVICE TANK	S3I		S3U
S4U			4-57-0B-W	SW BALLAST TANK	S4U		
S4I			4-60-1-F	LO DRAIN TANK	S4I		
S4I			4-60-2-F	OILY WATER TANK	S4I		
S4I			2-57-0-L	PASSAGE	S4U		
S4I			2-59-1-Q	ELEC/ELEX WORKSHOP &	S4U		
			2-6-1-Q	CHAIN LOCKER	(CUI = AG)		
S3U	S3U	S3U	4-0-0-W	SW BALLAST TANK	S3U	S3U	S3U
S3U		S3U	4-6-0C-W	SW BALLAST TANK	S3U		S3U
S3U		S3U	2-6-2-Q	CHAIN LOCKER	S3U		S3U
S3U		S3U	2-10-0-F	HYD OIL STG TANK	S3U		S3U
S4U			3-6-0-Q	CHAIN LOCKER SUMP	S4U		
S4U			1-6-1-A	BOATSWAIN STOREROOM	S4U		
S4U			1-12-1B-L	PASSAGE	S4U		
			2-6-2-Q	CHAIN LOCKER	(CUI = AG)		
S3U	S3U	S3U	4-0-0-W	SW BALLAST TANK	S3U	S3U	S3U
S3U		S3U	4-6-0A-W	SW BALLAST TANK	S3U		S3U
S3U		S3U	2-6-1-Q	CHAIN LOCKER	S3U		S3U
S3U		S3U	2-10-0-F	HYD OIL STG TANK	S3U		S3U
S4U			3-6-0-Q	CHAIN LOCKER SUMP	S4U		
S4U			1-6-2-A	FLAM. LIQ. STOREROOM	S4U		
			2-21-0-L	PASSAGE	(CUI = LP)		
S3U	S3U	S3U	4-12-0-E	BOWTHRUSTER MCHRY RO	S3U	S3U	S3U
S3U		S3U	3-23-0-Q	CRANE PEDESTAL	S3U		S3U
S3U		S3U	3-23-0-Q	CRANE PEDESTAL	S3U		S3U
S3U		S3U	3-23-0-Q	CRANE PEDESTAL	S3U		S3U
000		000	2-21-1-A	SUPPLY DEPT STOREROO	000		000

Table D.2 Barrier Data

Ship Visit Barrier Materials			Plan ID	Compartment Name Adjacent Compartment	Preliminary Baseline Barrier Materials		
<1>	<2>	<3>			<1>	<2>	<3>
S3U		S3U	2-21-2-Q	POTABLE WATER PUMP R	S3U		S3U
S3U		S3I	2-25-1-WW	POTABLE WATER (CARGO	S3I		S3U
S3U		S3I	2-25-1-WW	POTABLE WATER (CARGO	S3I		S3U
S3U		S3I	2-25-2-W	POTABLE WATER (SHIP)	S3I		S3U
S3U	S3U	S3U	2-30-0-AA	CARGO HOLD	S3U	S3U	S3U
S4U			4-21-0C-W	SW BALLAST TANK	S4U		
S4U			3-21-0-L	PASSAGE	S4U		
S4I			1-21-1-L	VESTIBULE	S4U		
S4I			1-21-2-Q	ATON SHOP	S4U		
S4I			1-21-3-L	COMPANIONWAY	S4U		
S4I			(none)	(weather overhead)	S4U		
			2-21-1-A	SUPPLY DEPT STOREROOM NO. 1	(CUI = AS)		
S3U	S3U	S3U	4-12-0-E	BOWTHRUSTER MCHRY RO	S3U	S3U	S3U
000		000	2-21-0-L	PASSAGE	000		000
S3U	S3U	S3U	2-30-0-AA	CARGO HOLD	S3U	S3U	S3U
S2I	S5U		(none)	(weather bulkhead)	S2I	S5U	
S4U			4-21-0C-W	SW BALLAST TANK	S4U		
S4I			1-21-3-L	COMPANIONWAY	S4U		
S4I			(none)	(weather overhead)	S4U		
			2-21-2-Q	POTABLE WATER PUMP ROOM	(CUI = QA)		
S3U	S3U	S3U	4-12-0-E	BOWTHRUSTER MCHRY RO	S3U	S3U	S3U
S3U		S3U	2-21-0-L	PASSAGE	S3U		S3U
S3U		S3I	2-25-2-W	POTABLE WATER (SHIP)	S3I		S3U
S3U		S3I	2-25-2-W	POTABLE WATER (SHIP)	S3I		S3U
S3U	S3U	S3U	2-30-0-AA	CARGO HOLD	S3U	S3U	S3U
S2I	S5U		(none)	(weather bulkhead)	S2I	S5U	
S4U			4-21-0A-W	SW BALLAST TANK	S4U		
S4U			3-21-0-L	PASSAGE	S4U		
S4I			1-21-2-Q	ATON SHOP	S4U		
S4I			(none)	(weather overhead)	S4U		
			2-25-1-WW	POTABLE WATER (CARGO)	(CUI = W)		
S3I		S3U	3-23-0-Q	CRANE PEDESTAL	S3U		S3I
S3I		S3U	3-23-0-Q	CRANE PEDESTAL	S3U		S3I
S3I		S3U	2-21-0-L	PASSAGE	S3U		S3I
S3I		S3U	2-21-0-L	PASSAGE	S3U		S3I
S3U		S3U	2-25-2-W	POTABLE WATER (SHIP)	S3U		S3U
S3U	S3U	S3U	2-30-0-AA	CARGO HOLD	S3U	S3U	S3U
S4U			3-25-1-M	MAGAZINE NO. 1	S4U		
S4U			(none)	(weather overhead)	S4U		
			2-25-2-W	POTABLE WATER (SHIP)	(CUI = W)		
S3I		S3U	3-23-0-Q	CRANE PEDESTAL	S3U		S3I
S3I		S3U	3-23-0-Q	CRANE PEDESTAL	S3U		S3I
S3I		S3U	2-21-0-L	PASSAGE	S3U		S3I
S3I		S3U	2-21-2-Q	POTABLE WATER PUMP R	S3U		S3I
S3I		S3U	2-21-2-Q	POTABLE WATER PUMP R	S3U		S3I
S3U		S3U	2-25-1-WW	POTABLE WATER (CARGO)	S3U		S3U

Table D.2 Barrier Data

Ship Visit Barrier Materials			Plan ID	Compartment Name Adjacent Compartment	Preliminary Baseline Barrier Materials		
<1>	<2>	<3>			<1>	<2>	<3>
S3U	S3U	S3U	2-30-0-AA	CARGO HOLD	S3U	S3U	S3U
S4U			3-25-2-M	MAGAZINE NO. 2	S4U		
S4U			(none)	(weather overhead)	S4U		
			2-30-0-AA	CARGO HOLD	(CUI = AA)		
S3U	S3U	S3U	2-21-0-L	PASSAGE	S3U	S3U	S3U
S3U	S3U	S3U	2-21-1-A	SUPPLY DEPT STOREROO	S3U	S3U	S3U
S3U	S3U	S3U	2-21-2-Q	POTABLE WATER PUMP R	S3U	S3U	S3U
S3U	S3U	S3U	2-25-1-WW	POTABLE WATER (CARGO	S3U	S3U	S3U
S3U	S3U	S3U	2-25-2-W	POTABLE WATER (SHIP)	S3U	S3U	S3U
S3I		S3U	2-36-1-L	PASSAGE	S3U		S3U
S3I		S3U	2-36-1-L	PASSAGE	S3U		S3U
S3I	S3U	S3U	2-39-0-V	COFFERDAM	S3U	S3U	S3U
S3I	S3U	S3U	2-39-2-V	VOID	S3U	S3U	S3U
S2I	S5U		(none)	(weather bulkhead)	S2I	S5U	
S2I	S5U		(none)	(weather bulkhead)	S2I	S5U	
S2I	S5U		(none)	(weather bulkhead)	S2I	S5U	
S4U			4-30-0-F	FUEL TANK	S4U		
S4U			4-30-1-F	FUEL TANK	S4U		
S4U			4-30-2-F	FUEL TANK	S4U		
S4U			4-30-3-W	SW BALLAST TANK	S4U		
S4U			4-30-4-W	SW BALLAST TANK	S4U		
S4U			4-37-2-V	VOID	S4U		
S4I			(none)	(weather overhead)	S4I		
			2-36-1-L	PASSAGE	(CUI = LP)		
S3U		S3I	2-30-0-AA	CARGO HOLD	S3U		S3U
S3U		S3I	2-30-0-AA	CARGO HOLD	S3U		S3U
S3U	S3U	S3U	2-39-1-L	PASSAGE	S3U	S3U	S3U
S2I	S5U		(none)	(weather bulkhead)	S2I	S5U	
S4U			4-30-3-W	SW BALLAST TANK	S4U		
S4I			(none)	(weather overhead)	S4I		
			2-39-0-V	COFFERDAM	(CUI = V)		
S3U		S3U	3-39-0-FF	SOR TANK	S3U		S3U
S3U	S3U	S3I	2-30-0-AA	CARGO HOLD	S3U	S3U	S3U
S3I		S3U	2-39-1-L	PASSAGE	S3U		S3I
S3I		S3U	2-39-2-V	VOID	S3U		S3I
S4U			3-39-0-FF	SOR TANK	S4U		
S4I			(none)	(weather overhead)	S4I		
			2-39-1-L	PASSAGE	(CUI = LP)		
S3I		S3U	3-39-0-FF	SOR TANK	S3I		S3U
S3U	S3U	S3U	2-36-1-L	PASSAGE	S3U	S3U	S3U
S3U		S3I	2-39-0-V	COFFERDAM	S3I		S3U
S3U	S3U	S3I	2-48-1-L	PASSAGE	S3U	S3U	S3U
S2I	S5U		(none)	(weather bulkhead)	S2I	S5U	
S4U			4-39-0C-V	VOID	S4U		
S4I			(none)	(weather overhead)	S4I		
			2-39-2-V	VOID	(CUI = V)		

Table D.2 Barrier Data

Ship Visit Barrier Materials			Plan ID	Compartment Name	Preliminary Baseline Barrier Materials		
<1>	<2>	<3>			Adjacent Compartment	<1>	<2>
S3I		S3U	3-39-0-FF	SOR TANK	S3I		S3U
S3U	S3U	S3I	2-30-0-AA	CARGO HOLD	S3U	S3U	S3U
S3U		S3I	2-39-0-V	COFFERDAM	S3I		S3U
S3I	S3U	S3U	2-48-2-E	SOR PUMP ROOM	S3U	S3U	S3I
S2U	S5U		(none)	(weather bulkhead)	S2U	S5U	
S4U			4-39-0A-V	VOID	S4U		
S4I			(none)	(weather overhead)	S4I		
			2-48-0-V	COFFERDAM	(CUI = V)		
S3U	S3U	S3U	3-39-0-FF	SOR TANK	S3U	S3U	S3U
S3I		S3U	2-48-1-L	PASSAGE	S3U		S3I
S3I		S3U	2-48-2-E	SOR PUMP ROOM	S3U		S3I
S3I		S3U	2-49-0-E	SOR MACHINERY ROOM	S3U		S3I
S4U			3-48-0-FF	CARGO FUEL TANK	S4U		
S4I			(none)	(weather overhead)	S4I		
			2-48-1-L	PASSAGE	(CUI = LP)		
S3U	S3U	S3I	3-39-0-FF	SOR TANK	S3I	S3U	S3U
S3I	S3U	S3U	2-39-1-L	PASSAGE	S3U	S3U	S3U
S3U		S3I	2-48-0-V	COFFERDAM	S3I		S3U
S3U		S3I	2-49-0-E	SOR MACHINERY ROOM	S3U		S3U
000		000	2-50-1-A	ENGINEER STOREROOM	000		000
000		000	2-50-1-A	ENGINEER STOREROOM	000		000
S3U		S3U	2-53-1-L	VESTIBULE	S3U		S3U
S2I	S5U		(none)	(weather bulkhead)	S2I	S5U	
S4U			4-48-0C-W	SW BALLAST TANK	S4U		
S4U			3-48-0-FF	CARGO FUEL TANK	S4U		
S4U			3-48-1-F	FUEL TANK	S4U		
S4U			3-51-0-V	VOID	S4U		
S4I			(none)	(weather overhead)	S4I		
			2-48-2-E	SOR PUMP ROOM	(CUI = QA)		
S3U	S3U	S3I	3-39-0-FF	SOR TANK	S3I	S3U	S3U
S3U	S3U	S3I	2-39-2-V	VOID	S3I	S3U	S3U
S3U		S3I	2-48-0-V	COFFERDAM	S3I		S3U
S3U		S3I	2-49-0-E	SOR MACHINERY ROOM	S3U		S3U
S3U	S3U	S3U	2-57-2-A	SHIP STORE	S3U	S3U	S3U
S3U	S3U	S3U	2-57-4-E	WATER SUPPLY EQPT RO	S3U	S3U	S3U
S2I	S5U		(none)	(weather bulkhead)	S2I	S5U	
S4U			4-48-0A-W	SW BALLAST TANK	S4U		
S4U			3-48-2-F	FUEL TANK	S4U		
S4I			(none)	(weather overhead)	S4I		
			2-49-0-E	SOR MACHINERY ROOM	(CUI = QA)		
S3U		S3I	2-48-0-V	COFFERDAM	S3I		S3U
S3I		S3U	2-48-1-L	PASSAGE	S3U		S3U
S3I		S3U	2-48-2-E	SOR PUMP ROOM	S3U		S3U
S3I		S3U	2-53-1-L	VESTIBULE	S3U		S3U
S3I		S3U	2-53-1-L	VESTIBULE	S3U		S3U
S3I		S3U	2-53-1-L	VESTIBULE	S3U		S3U

Table D.2 Barrier Data

Ship Visit Barrier Materials			Plan ID	Compartment Name Adjacent Compartment	Preliminary Baseline Barrier Materials		
<1>	<2>	<3>			<1>	<2>	<3>
S3I	S3U	S3U	2-57-0-L	PASSAGE	S3U	S3U	S3U
S4U			3-48-0-FF	CARGO FUEL TANK	S4U		
S4U			3-51-0-V	VOID	S4U		
S4U			3-54-0-F	FUEL OIL OVFL TANK	S4U		
S4I			(none)	(weather overhead)	S4I		
			2-50-1-A	ENGINEER STOREROOM	(CUI = AS)		
000		000	2-48-1-L	PASSAGE	000		000
000		000	2-48-1-L	PASSAGE	000		000
S3U		S3U	2-53-1-L	VESTIBULE	S3U		S3U
S3U	S3U	S3U	2-57-1-Q	MACHINE SHOP	S3U	S3U	S3U
S2I	S5U		(none)	(weather bulkhead)	S2I	S5U	
S4U			4-48-0C-W	SW BALLAST TANK	S4U		
S4U			3-48-1-F	FUEL TANK	S4U		
S4I			(none)	(weather overhead)	S4I		
			2-53-1-L	VESTIBULE	(CUI = LP)		
S3U		S3U	2-48-1-L	PASSAGE	S3U		S3U
S3U		S3I	2-49-0-E	SOR MACHINERY ROOM	S3U		S3U
S3U		S3I	2-49-0-E	SOR MACHINERY ROOM	S3U		S3U
S3U		S3I	2-49-0-E	SOR MACHINERY ROOM	S3U		S3U
S3U		S3U	2-50-1-A	ENGINEER STOREROOM	S3U		S3U
S3U	S3U	S3U	2-57-0-L	PASSAGE	S3U	S3U	S3U
S4U			3-48-1-F	FUEL TANK	S4U		
S4U			3-51-0-V	VOID	S4U		
S4U			3-54-0-F	FUEL OIL OVFL TANK	S4U		
S4U			(none)	(weather overhead)	S4I		
			2-57-0-L	PASSAGE	(CUI = LP)		
S3I	S3U	S3I	4-66-0-E	MAIN MACHINERY ROOM	S3U	S3U	S3U
S3U	S3U	S3I	2-49-0-E	SOR MACHINERY ROOM	S3U	S3U	S3U
S3U	S3U	S3U	2-53-1-L	VESTIBULE	S3U	S3U	S3U
S3U		S3U	2-57-1-Q	MACHINE SHOP	S3U		S3U
000		000	2-57-2-A	SHIP STORE	NPU		S2U
S3U		NPU	2-57-4-E	WATER SUPPLY EQPT RO	NPU		S3U
S3U		S3U	2-59-1-Q	ELEC/ELEX WORKSHOP &	S3U		S3U
S3U		S3U	2-59-1-Q	ELEC/ELEX WORKSHOP &	S3U		S3U
S4U			4-57-0C-W	SW BALLAST TANK	S4U		
S4I			3-57-0-A	SUPPLY DEPT. STORERO	S4U		
S4U			1-57-0-L	DECK WR & WC	S4U		
S4U			1-57-1-Q	GALLEY	S4U		
S4U			1-57-2-L	PASSAGE	S4U		
S4U			1-57-3-Q	DUMBWAITER TRUNK	S4U		
S4U			1-59-2-L	COMPANIONWAY	S4U		
			2-57-1-Q	MACHINE SHOP	(CUI = QS)		
S3U	S3U	S3I	4-66-0-E	MAIN MACHINERY ROOM	S3U	S3U	S3U
S3U	S3U	S3U	2-50-1-A	ENGINEER STOREROOM	S3U	S3U	S3U
S3U		S3U	2-57-0-L	PASSAGE	S3U		S3U
S3U		S3U	2-59-1-Q	ELEC/ELEX WORKSHOP &	S3U		S3U

Table D.2 Barrier Data

Ship Visit Barrier Materials			Plan ID	Compartment Name	Preliminary Baseline Barrier Materials		
<1>	<2>	<3>			Adjacent Compartment	<1>	<2>
S2I	S5U		(none)	(weather bulkhead)	S2I	S5U	
S4U			4-57-0C-W	SW BALLAST TANK	S4U		
S4U			3-61-1-F	FUEL SERVICE TANK	S4U		
S4I			1-57-1-Q	GALLEY	S4U		
S4I			1-57-3-Q	DUMBWAITER TRUNK	S4U		
			2-57-2-A	SHIP STORE	(CUI = AS)		
S3U	S3U	S3U	2-48-2-E	SOR PUMP ROOM	S3U	S3U	S3U
000		000	2-57-0-L	PASSAGE	S2U		NPU
S3U		S3U	2-57-4-E	WATER SUPPLY EQPT RO	S3U		S3U
S3U		S3U	2-57-4-E	WATER SUPPLY EQPT RO	S3U		S3U
S4U			4-57-0A-W	SW BALLAST TANK	S4U		
S4U			1-57-2-L	PASSAGE	S4U		
S4U			1-57-4-Q	CHANGE ROOM	S4U		
S4U			1-60-2-A	CHILL STRM	S4U		
S4U			1-60-4-A	FREEZE STRM	S4U		
			2-57-4-E	WATER SUPPLY EQPT ROOM	(CUI = QA)		
S3U	S3U	S3I	4-66-0-E	MAIN MACHINERY ROOM	S3U	S3U	S3U
S3U	S3U	S3U	2-48-2-E	SOR PUMP ROOM	S3U	S3U	S3U
NPU		S3U	2-57-0-L	PASSAGE	S3U		NPU
S3U		S3U	2-57-2-A	SHIP STORE	S3U		S3U
S3U		S3U	2-57-2-A	SHIP STORE	S3U		S3U
S2I	S5U		(none)	(weather bulkhead)	S2I	S5U	
S4U			4-57-0A-W	SW BALLAST TANK	S4U		
S4U			3-62-2-F	FUEL SERVICE TANK	S4U		
S4I			1-57-2-L	PASSAGE	S4U		
S4I			1-57-4-Q	CHANGE ROOM	S4U		
S4I			1-60-2-A	CHILL STRM	S4U		
S4I			1-60-4-A	FREEZE STRM	S4U		
S4I			1-60-6B-A	DRY PROVISION STORER	S4U		
			2-59-1-Q	ELEC/ELEX WORKSHOP & STORERM	(CUI = QS)		
S3I	S3U	S3I	4-66-0-E	MAIN MACHINERY ROOM	S3U	S3U	S3U
S3U		S3U	2-57-0-L	PASSAGE	S3U		S3U
S3U		S3U	2-57-0-L	PASSAGE	S3U		S3U
S3U		S3U	2-57-1-Q	MACHINE SHOP	S3U		S3U
S4U			4-57-0C-W	SW BALLAST TANK	S4U		
S4I			3-57-0-A	SUPPLY DEPT. STORERO	S4U		
S4U			3-61-1-F	FUEL SERVICE TANK	S4U		
S4U			1-57-0-L	DECK WR & WC	S4U		
S4U			1-57-1-Q	GALLEY	S4U		
S4U			1-60-1-L	GALLEY WR & WC	S4U		
			2-89-1-C	ENGINEERING CONTROL CENTER	(CUI = C)		
S3U		S3I	4-66-0-E	MAIN MACHINERY ROOM	S3I		S3U
S3U		S3I	4-66-0-E	MAIN MACHINERY ROOM	S3I		S3U
S3U	S3U	S3I	4-82-0-E	AUXILIARY MACHINERY	S3I	S3U	S3U
S2I	S5U		(none)	(weather bulkhead)	S2I	S5U	
S4U			4-66-0-E	MAIN MACHINERY ROOM	S4U		

Table D.2 Barrier Data

Ship Visit Barrier Materials			Plan ID	Compartment Name Adjacent Compartment	Preliminary Baseline Barrier Materials		
<1>	<2>	<3>			<1>	<2>	<3>
S4I			1-66-0-L	CREW MESS	S4I		
S4I			1-66-3-Q	SCULLERY	S4I		
S4I			1-77-3-L	CREW LOUNGE	S4I		
			1-0-0-A	BOATSWAIN STOREROOM NO. 1	(CUI = AS)		
S3U		S3U	1-6-1-A	BOATSWAIN STOREROOM	S3U		S3U
S3U		S3U	1-6-2-A	FLAM. LIQ. STOREROOM	S3U		S3U
S2I	S3U		(none)	(weather bulkhead)	S2I	S3U	
S2I	S3U		(none)	(weather bulkhead)	S2I	S3U	
S2I	S3U		(none)	(weather bulkhead)	S2I	S3U	
S2I	S3U		(none)	(weather bulkhead)	S2I	S3U	
S4U			4-0-0-W	SW BALLAST TANK	S4U		
S4I			(none)	(weather overhead)	S4I		
			1-6-1-A	BOATSWAIN STOREROOM NO. 2	(CUI = AS)		
S3U		S3U	1-0-0-A	BOATSWAIN STOREROOM	S3U		S3U
S3U		S3I	1-6-2-A	FLAM. LIQ. STOREROOM	S3U		S3U
000		000	1-12-1B-L	PASSAGE	000		000
000		000	1-12-1B-L	PASSAGE	000		000
S3U		S3I	1-12-3-Q	BOATSWAIN SHOP	S3U		S3U
S2I	S3U		(none)	(weather bulkhead)	S2I	S3U	
S4U			4-6-0C-W	SW BALLAST TANK	S4U		
S4U			2-6-1-Q	CHAIN LOCKER	S4U		
S4U			2-10-0-F	HYD OIL STG TANK	S4U		
S4I			(none)	(weather overhead)	S4I		
			1-6-2-A	FLAM. LIQ. STOREROOM	(CUI = K)		
S3U		S3U	1-0-0-A	BOATSWAIN STOREROOM	S3U		S3U
S3I		S3U	1-6-1-A	BOATSWAIN STOREROOM	S3U		S3U
S3I		S3U	1-12-1B-L	PASSAGE	S3U		S3U
S3U		S3U	1-12-2-M	ARMORY	S3U		S3U
S3I	S3U		(none)	(weather bulkhead)	S3U	S3U	
S4U			4-6-0A-W	SW BALLAST TANK	S4U		
S4U			2-6-2-Q	CHAIN LOCKER	S4U		
S4U			2-10-0-F	HYD OIL STG TANK	S4U		
S4I			(none)	(weather overhead)	S4I		
			1-12-1A-L	PASSAGE	(CUI = LP)		
S3U		S3U	1-12-1B-L	PASSAGE	S3U		S3U
S3U		S3U	1-12-2-M	ARMORY	S3U		S3U
S3U		S3I	1-12-3-Q	BOATSWAIN SHOP	S3U		S3U
S2U		S2U	1-15-1-L	COMPANIONWAY	S2U		S2U
S2U		S2U	1-15-1-L	COMPANIONWAY	S2U		S2U
S3U		S3U	1-18-1-Q	D.C. REPAIR LKR NO.	S3U		S3U
000		000	1-18-2-Q	AFF STA.	000		000
S3U		S3I	1-21-1-L	VESTIBULE	S3U		S3U
S4U			4-12-0-E	BOWTHRUSTER MCHRY RO	S4U		
S4I			(none)	(weather overhead)	S4I		
			1-12-1B-L	PASSAGE	(CUI = LP)		
000		000	1-6-1-A	BOATSWAIN STOREROOM	000		000

Table D.2 Barrier Data

Ship Visit Barrier Materials			Plan ID	Compartment Name	Preliminary Baseline Barrier Materials		
<1>	<2>	<3>			Adjacent Compartment	<1>	<2>
000		000	1-6-1-A	BOATSWAIN STOREROOM	000		000
S3U		S3I	1-6-2-A	FLAM. LIQ. STOREROOM	S3U		S3U
S3U		S3U	1-12-1A-L	PASSAGE	S3U		S3U
S4U			2-6-1-Q	CHAIN LOCKER	S4U		
S4U			2-10-0-F	HYD OIL STG TANK	S4U		
S4I			(none)	(weather overhead)	S4I		
			1-12-3-Q	BOATSWAIN SHOP	(CUI = QS)		
S3I		S3U	1-6-1-A	BOATSWAIN STOREROOM	S3U		S3U
S3I		S3U	1-12-1A-L	PASSAGE	S3U		S3U
S3I		S3U	1-15-1-L	COMPANIONWAY	S3U		S3U
S3I		S3U	1-15-1-L	COMPANIONWAY	S3U		S3U
S3I		S3U	1-18-1-Q	D.C. REPAIR LKR NO.	S3U		S3U
S2I	S3U		(none)	(weather bulkhead)	S2I	S3U	
S4U			4-12-0-E	BOWTHRUSTER MCHRY RO	S4U		
S4U			2-13-1-F	HPU RESERVOIR	S4U		
S4I			(none)	(weather overhead)	S4I		
			1-15-1-L	COMPANIONWAY	(CUI = LP)		
S2U		S2U	1-12-1A-L	PASSAGE	S2U		S2U
S2U		S2U	1-12-1A-L	PASSAGE	S2U		S2U
S3U		S3I	1-12-3-Q	BOATSWAIN SHOP	S3U		S3U
S3U		S3I	1-12-3-Q	BOATSWAIN SHOP	S3U		S3U
S3U		S3U	1-18-1-Q	D.C. REPAIR LKR NO.	S3U		S3U
S4U			4-12-0-E	BOWTHRUSTER MCHRY RO	S4U		
S4U			2-13-1-F	HPU RESERVOIR	S4U		
S4I			(none)	(weather overhead)	S4I		
			1-18-1-Q	D.C. REPAIR LKR NO. 1	(CUI = QA)		
S3U		S3U	1-12-1A-L	PASSAGE	S3U		S3U
S3U		S3I	1-12-3-Q	BOATSWAIN SHOP	S3U		S3U
S3U		S3U	1-15-1-L	COMPANIONWAY	S3U		S3U
S3U		S3U	1-21-3-L	COMPANIONWAY	S3U		S3U
S2I	S3U		(none)	(weather bulkhead)	S2I	S3U	
S4U			4-12-0-E	BOWTHRUSTER MCHRY RO	S4U		
S4I			(none)	(weather overhead)	S4I		
			1-18-2-Q	AFFF STA.	(CUI = QA)		
000		000	1-12-1A-L	PASSAGE	000		000
S3U		S3U	1-12-2-M	ARMORY	S3U		S3U
S3U		S3U	1-18-4-A	ATON STRM	S3U		S3U
S3U		S3U	1-19-2-T	ESC TRUNK	S3U		S3U
S3U		S3I	1-21-2-Q	ATON SHOP	S3U		S3U
S4U			4-12-0-E	BOWTHRUSTER MCHRY RO	S4U		
S4I			(none)	(weather overhead)	S4I		
			1-18-4-A	ATON STRM	(CUI = AS)		
S3I		S3U	1-12-2-M	ARMORY	S3U		S3U
S3U		S3U	1-18-2-Q	AFFF STA.	S3U		S3U
S3U		S3U	1-19-2-T	ESC TRUNK	S3U		S3U
S3U		S3U	1-19-2-T	ESC TRUNK	S3U		S3U

Table D.2 Barrier Data

Ship Visit Barrier Materials			Plan ID	Compartment Name Adjacent Compartment	Preliminary Baseline Barrier Materials		
<1>	<2>	<3>			<1>	<2>	<3>
S3U		S3I	1-21-2-Q	ATON SHOP	S3U		S3U
S2I	S3U		(none)	(weather bulkhead)	S2I	S3U	
S4U			4-12-0-E	BOWTHRUSTER MCHRY RO	S4U		
S4U			2-13-2-F	HPU RESERVOIR	S4U		
S4I			(none)	(weather overhead)	S4I		
			1-19-2-T	ESC TRUNK	(CUI = TH)		
S3U		S3U	1-18-2-Q	AFFF STA.	S3U		S3U
S3U		S3U	1-18-4-A	ATON STRM	S3U		S3U
S3U		S3U	1-18-4-A	ATON STRM	S3U		S3U
S3U		S3I	1-21-2-Q	ATON SHOP	S3U		S3U
S4U			4-12-0-E	BOWTHRUSTER MCHRY RO	S4U		
S4U			(none)	(weather overhead)	S4U		
			1-21-1-L	VESTIBULE	(CUI = LP)		
S3I		S3U	3-23-0-Q	CRANE PEDESTAL	S3U		S3U
S3I		S3U	3-23-0-Q	CRANE PEDESTAL	S3U		S3U
S3I		S3U	1-12-1A-L	PASSAGE	S3U		S3U
S3I		S3I	1-21-2-Q	ATON SHOP	S3U		S3U
S3I		S3U	1-21-3-L	COMPANIONWAY	S3U		S3U
S3I	S3U		(none)	(weather bulkhead)	S3I	S3U	
S4I			2-21-0-L	PASSAGE	S4U		
S4I			(none)	(weather overhead)	S4I		
			1-21-2-Q	ATON SHOP	(CUI = QS)		
S3I		S3U	3-23-0-Q	CRANE PEDESTAL	S3U		S3U
S3I		S3U	3-23-0-Q	CRANE PEDESTAL	S3U		S3U
S3I		S3U	1-18-2-Q	AFFF STA.	S3U		S3U
S3I		S3U	1-18-4-A	ATON STRM	S3U		S3U
S3I		S3U	1-19-2-T	ESC TRUNK	S3U		S3U
S3I		S3I	1-21-1-L	VESTIBULE	S3U		S3U
S3I	S3U		(none)	(weather bulkhead)	S3I	S3U	
S2I	S3U		(none)	(weather bulkhead)	S2I	S3U	
S4I			2-21-0-L	PASSAGE	S4U		
S4I			2-21-2-Q	POTABLE WATER PUMP R	S4U		
S4I			(none)	(weather overhead)	S4I		
			1-21-3-L	COMPANIONWAY	(CUI = LP)		
S3U		S3U	1-18-1-Q	D.C. REPAIR LKR NO.	S3U		S3U
S3U		S3I	1-21-1-L	VESTIBULE	S3U		S3U
S3I	S3U		(none)	(weather bulkhead)	S3I	S3U	
S2I	S3U		(none)	(weather bulkhead)	S2I	S3U	
S4I			2-21-0-L	PASSAGE	S4U		
S4I			2-21-1-A	SUPPLY DEPT STOREROO	S4U		
S4I			(none)	(weather overhead)	S4I		
			1-57-0-L	DECK WR & WC	(CUI = LW)		
S3U		S3U	1-57-1-Q	GALLEY	S3U		S3U
S3U		S3I	1-57-2-L	PASSAGE	S3U		S3U
S3U		S3U	1-59-2-L	COMPANIONWAY	S3U		S3U
S3U		S3U	1-59-2-L	COMPANIONWAY	S3U		S3U

Table D.2 Barrier Data

Ship Visit Barrier Materials			Plan ID	Compartment Name Adjacent Compartment	Preliminary Baseline Barrier Materials		
<1>	<2>	<3>			<1>	<2>	<3>
NPU		NPU	1-60-1-L	GALLEY WR & WC	NPU		NPU
S3I	S3U		(none)	(weather bulkhead)	S3I	S3U	
S4U			2-57-0-L	PASSAGE	S4U		
S4U			2-59-1-Q	ELEC/ELEX WORKSHOP &	S4U		
S4U			01-57-0-Q	WARD ROOM PANTRY	S4U		
S4U			01-57-2-L	CPO SR	S4U		
			1-57-1-Q	GALLEY	(CUI = QG)		
S3U		S3U	1-57-0-L	DECK WR & WC	S3U		S3U
S3U		S3I	1-57-2-L	PASSAGE	S3U		S3U
S3U		S3I	1-57-3-Q	DUMBWAITER TRUNK	S3I		S3U
S3U		S3I	1-57-3-Q	DUMBWAITER TRUNK	S3I		S3U
S3U		S3I	1-57-3-Q	DUMBWAITER TRUNK	S3I		S3U
S3U		S3U	1-60-1-L	GALLEY WR & WC	S3U		S3U
S3U		S3U	1-60-1-L	GALLEY WR & WC	S3U		S3U
S3U		S3U	1-66-1-Q	GALLEY ANNEX	S3U		S3U
S3U		S3U	1-66-3-Q	SCULLERY	S3U		S3U
S2I	S3U		(none)	(weather bulkhead)	S2I	S3U	
S3U	S3U		(none)	(weather bulkhead)	S3I	S3U	
S3U	S3U		(none)	(weather bulkhead)	S3I	S3U	
S4U			2-57-0-L	PASSAGE	S4U		
S4I			2-57-1-Q	MACHINE SHOP	S4U		
S4U			2-59-1-Q	ELEC/ELEX WORKSHOP &	S4U		
S4U			01-57-0-Q	WARD ROOM PANTRY	S4U		
S4U			01-60-1-L	WARDROOM MESSROOM &	S4U		
S4U			(none)	(weather overhead)	S4U		
			1-57-2-L	PASSAGE	(CUI = LP)		
S3I		S3U	1-57-0-L	DECK WR & WC	S3U		S3U
S3I		S3U	1-57-1-Q	GALLEY	S3U		S3U
S3I		S3U	1-57-4-Q	CHANGE ROOM	S3U		S3U
S3I		S3U	1-59-2-L	COMPANIONWAY	S3U		S3U
S3I		S3U	1-59-2-L	COMPANIONWAY	S3U		S3U
S3I		S3I	1-60-2-A	CHILL STRM	NPI		NPI
S3I		S3U	1-60-6B-A	DRY PROVISION STORER	S3U		S3U
S3I		S3U	1-66-0-L	CREW MESS	S3U		S3U
S3I		S3I	1-66-2-L	COMPANIONWAY	S3U		S3U
S3U	S3U		(none)	(weather bulkhead)	S3I	S3U	
S4U			2-57-0-L	PASSAGE	S4U		
S4U			2-57-2-A	SHIP STORE	S4U		
S4I			2-57-4-E	WATER SUPPLY EQPT RO	S4U		
S4U			01-57-2-L	CPO SR	S4U		
S4U			01-60-0C-L	PASSAGE	S4U		
S4U			01-83-2-L	CPO SR	S4U		
			1-57-3-Q	DUMBWAITER TRUNK	(CUI = TH)		
S3I		S3U	1-57-1-Q	GALLEY	S3U		S3I
S3I		S3U	1-57-1-Q	GALLEY	S3U		S3I
S3I		S3U	1-57-1-Q	GALLEY	S3U		S3I

Table D.2 Barrier Data

Ship Visit Barrier Materials			Plan ID	Compartment Name	Preliminary Baseline Barrier Materials		
<1>	<2>	<3>			Adjacent Compartment	<1>	<2>
S3U		S3I	01-57-0-Q	WARD ROOM PANTRY	S3U		S3I
S3U		S3I	01-57-0-Q	WARD ROOM PANTRY	S3U		S3I
S3U		S3I	01-57-0-Q	WARD ROOM PANTRY	S3U		S3I
S3I	S3U		(none)	(weather bulkhead)	S3U	S3U	
S3I	S3U		(none)	(weather bulkhead)	S3U	S3U	
S4U			2-57-0-L	PASSAGE	S4U		
S4I			2-57-1-Q	MACHINE SHOP	S4U		
S4U			02-57-0-L	CO CABIN	S4U		
			1-57-4-Q	CHANGE ROOM	(CUI = LW)		
S3U		S3I	1-57-2-L	PASSAGE	S3U		S3U
NPI		S3I	1-60-2-A	CHILL STRM	S3U		NPI
NPI		S3I	1-60-4-A	FREEZE STRM	S3U		NPI
S3U		S3U	1-60-6B-A	DRY PROVISION STORER	S3U		S3U
S3I	S3U		(none)	(weather bulkhead)	S3I	S3U	
S2I	S3U		(none)	(weather bulkhead)	S2I	S3U	
S4U			2-57-2-A	SHIP STORE	S4U		
S4I			2-57-4-E	WATER SUPPLY EQPT RO	S4U		
S4U			01-57-2-L	CPO SR	S4U		
S4U			01-57-4-L	CPO WR, WC, SH	S4U		
S4I			(none)	(weather overhead)	S4U		
			1-59-2-L	COMPANIONWAY	(CUI = LP)		
S3U		S3U	1-57-0-L	DECK WR & WC	S3U		S3U
S3U		S3U	1-57-0-L	DECK WR & WC	S3U		S3U
S3U		S3I	1-57-2-L	PASSAGE	S3U		S3U
S3U		S3I	1-57-2-L	PASSAGE	S3U		S3U
S3U		S3U	1-60-1-L	GALLEY WR & WC	S3U		S3U
S4U			2-57-0-L	PASSAGE	S4U		
S4U			01-57-0-Q	WARD ROOM PANTRY	S4U		
S4U			01-57-2-L	CPO SR	S4U		
S4U			01-60-0C-L	PASSAGE	S4U		
			1-60-1-L	GALLEY WR & WC	(CUI = LW)		
NPU		NPU	1-57-0-L	DECK WR & WC	NPU		NPU
S3U		S3U	1-57-1-Q	GALLEY	S3U		S3U
S3U		S3U	1-57-1-Q	GALLEY	S3U		S3U
S3U		S3U	1-59-2-L	COMPANIONWAY	S3U		S3U
S4U			2-59-1-Q	ELEC/ELEX WORKSHOP &	S4U		
S4U			01-60-1-L	WARDROOM MESSROOM &	S4U		
			1-60-2-A	CHILL STRM	(CUI = AR)		
S3I		S3I	1-57-2-L	PASSAGE	NPI		NPI
S3I		NPI	1-57-4-Q	CHANGE ROOM	NPI		S3U
S3I		S3I	1-60-4-A	FREEZE STRM	NPI		NPI
S3I		NPI	1-60-6B-A	DRY PROVISION STORER	NPI		NPI
S4U			2-57-2-A	SHIP STORE	S4U		
S4I			2-57-4-E	WATER SUPPLY EQPT RO	S4U		
S4I			01-57-2-L	CPO SR	S4U		
S4I			01-57-4-L	CPO WR, WC, SH	S4U		

Table D.2 Barrier Data

Ship Visit Barrier Materials			Plan ID	Compartment Name Adjacent Compartment	Preliminary Baseline Barrier Materials		
<1>	<2>	<3>			<1>	<2>	<3>
S4I			01-83-2-L	CPO SR	S4U		
			1-60-4-A	FREEZE STRM	(CUI = AR)		
S3I		NPI	1-57-4-Q	CHANGE ROOM	NPI		S3U
S3I		S3I	1-60-2-A	CHILL STRM	NPI		NPI
S3I		NPI	1-60-6B-A	DRY PROVISION STORER	NPI		NPI
S3I		NPI	1-60-6B-A	DRY PROVISION STORER	NPI		NPI
S4U			2-57-2-A	SHIP STORE	S4U		
S4I			2-57-4-E	WATER SUPPLY EQPT RO	S4U		
S4I			01-57-4-L	CPO WR, WC, SH	S4U		
S4I			01-83-2-L	CFO SR	S4U		
S4I			(none)	(weather overhead)	S4U		
			1-60-6A-A	DRY PROVISION STOREROOM	(CUI = AS)		
000		000	1-60-6B-A	DRY PROVISION STORER	S3U		S3U
S3U		S3I	1-66-2-L	COMPANIONWAY	S3U		S3U
S3U		S3U	1-71-2-Q	ENG LOG OFFICE & DC	S3U		S3U
S2I	S3U		(none)	(weather bulkhead)	S2I	S3U	
S4I			4-66-0-E	MAIN MACHINERY ROOM	S4I		
S4I			01-66-2-L	PASSAGE	S4U		
S4I			01-70-2-Q	C.G. LKR	S4U		
S4I			(none)	(weather overhead)	S4U		
			1-60-6B-A	DRY PROVISION STOREROOM	(CUI = AS)		
S3U		S3I	1-57-2-L	PASSAGE	S3U		S3U
S3U		S3U	1-57-4-Q	CHANGE ROOM	S3U		S3U
NPI		S3I	1-60-2-A	CHILL STRM	NPI		NPI
NPI		S3I	1-60-4-A	FREEZE STRM	NPI		NPI
NPI		S3I	1-60-4-A	FREEZE STRM	NPI		NPI
000		000	1-60-6A-A	DRY PROVISION STORER	S3U		S3U
S3U		S3I	1-66-2-L	COMPANIONWAY	S3I		S3U
S2I	S3U		(none)	(weather bulkhead)	S2I	S3U	
S4I			2-57-4-E	WATER SUPPLY EQPT RO	S4U		
S4I			01-83-2-L	CPO SR	S4U		
S4I			(none)	(weather overhead)	S4U		
			1-66-0-L	CREW MESS	(CUI = LL)		
S3U		S3I	1-57-2-L	PASSAGE	S3U		S3U
S3U		S3U	1-66-1-Q	GALLEY ANNEX	S3U		S3U
S3U		S3U	1-66-1-Q	GALLEY ANNEX	S3U		S3U
S3U		S3I	1-66-2-L	COMPANIONWAY	S3U		S3U
S3U		S3I	1-66-2-L	COMPANIONWAY	S3U		S3U
S3U		S3I	1-66-2-L	COMPANIONWAY	S3U		S3U
S3U		S3I	1-66-2-L	COMPANIONWAY	S3U		S3U
S3U		S3U	1-66-3-Q	SCULLERY	S3U		S3U
S3U		S3U	1-66-3-Q	SCULLERY	S3U		S3U
S2U		S2U	1-71-2-Q	ENG LOG OFFICE & DC	S2U		S2U
S3U		S3U	1-74-2-Q	DC REPAIR LKR NO. 2	S3U		S3U
S3U		S3U	1-74-2-Q	DC REPAIR LKR NO. 2	S3U		S3U
S3U		S3I	1-76-0-Q	MMR (UPTAKE)	S3I		S3U

Table D.2 Barrier Data

Ship Visit Barrier Materials			Plan ID	Compartment Name	Preliminary Baseline Barrier Materials		
<1>	<2>	<3>			Adjacent Compartment	<1>	<2>
S3U		S3I	1-76-0-Q	MMR (UPTAKE)	S3I		S3U
S3U		S3U	1-76-0-Q	MMR (UPTAKE)	S3U		S3U
S2U		S2U	1-77-1-A	CREW LOCKER	S2U		S2U
S2U		S2U	1-77-2-L	CPO MESS & LOUNGE	S2U		S2U
NPU		NSU	1-77-3-L	CREW LOUNGE	NSU		NPU
S3U		S3U	1-82-0-L	PASSAGE	S3U		S3U
S2I	S3U		(none)	(weather bulkhead)	S2I	S3U	
S4I			4-66-0-E	MAIN MACHINERY ROOM	S4I		
S4I			2-89-1-C	ENGINEERING CONTROL	S4I		
S4U			01-60-0A-L	PASSAGE	S4U		
S4U			01-60-0B-L	PASSAGE	S4U		
S4U			01-66-2-L	PASSAGE	S4U		
S4U			01-68-0-Q	SHIP OFFICE	S4U		
S4U			01-68-1-L	MEDICAL TREATMENT RO	S4U		
S4U			01-71-2-L	CPO WR, WC, SH	S4U		
S4U			01-74-1-L	MEDICAL TREATMENT WR	S4U		
S4U			01-79-0A-L	PASSAGE	S4U		
S4U			(none)	(weather overhead)	S4U		
			1-66-1-Q	GALLEY ANNEX	(CUI = QG)		
S3U		S3U	1-57-1-Q	GALLEY	S3U		S3U
S3U		S3U	1-66-0-L	CREW MESS	S3U		S3U
S3U		S3U	1-66-0-L	CREW MESS	S3U		S3U
S3U		S3U	1-66-3-Q	SCULLERY	S3U		S3U
S4I			4-66-0-E	MAIN MACHINERY ROOM	S4I		
S4U			01-60-0B-L	PASSAGE	S4U		
S4U			01-68-0-Q	SHIP OFFICE	S4U		
S4U			01-68-1-L	MEDICAL TREATMENT RO	S4U		
			1-66-2-L	COMPANIONWAY	(CUI = LP)		
S3I		S3I	1-57-2-L	PASSAGE	S3U		S3U
S3I		S3U	1-60-6A-A	DRY PROVISION STORER	S3U		S3U
S3I		S3U	1-60-6B-A	DRY PROVISION STORER	S3U		S3I
S3I		S3U	1-66-0-L	CREW MESS	S3U		S3U
S3I		S3U	1-66-0-L	CREW MESS	S3U		S3U
S3I		S3U	1-66-0-L	CREW MESS	S3U		S3U
S3I		S3U	1-66-0-L	CREW MESS	S3U		S3U
S4I			4-66-0-E	MAIN MACHINERY ROOM	S4I		
S4I			01-66-2-L	PASSAGE	S4U		
S4I			01-70-2-Q	C.G. LKR	S4U		
			1-66-3-Q	SCULLERY	(CUI = QG)		
S3U		S3U	1-57-1-Q	GALLEY	S3U		S3U
S3U		S3U	1-66-0-L	CREW MESS	S3U		S3U
S3U		S3U	1-66-0-L	CREW MESS	S3U		S3U
S3U		S3U	1-66-1-Q	GALLEY ANNEX	S3U		S3U
S2I	S3U		(none)	(weather bulkhead)	S2I	S3U	
S4I			4-66-0-E	MAIN MACHINERY ROOM	S4I		
S4I			2-89-1-C	ENGINEERING CONTROL	S4I		

Table D.2 Barrier Data

Ship Visit Barrier Materials			Plan ID	Compartment Name Adjacent Compartment	Preliminary Baseline Barrier Materials		
<1>	<2>	<3>			<1>	<2>	<3>
S4U			01-60-0B-L	PASSAGE	S4U		
S4U			01-68-1-L	MEDICAL TREATMENT RO	S4U		
S4U			(none)	(weather overhead)	S4U		
			1-71-2-Q	ENG LOG OFFICE & DC CENTRAL	(CUI = QO)		
S3U		S3U	1-60-6A-A	DRY PROVISION STORER	S3U		S3U
S2U		S2U	1-66-0-L	CREW MESS	S2U		S2U
S3U		S3U	1-74-2-Q	DC REPAIR LKR NO. 2	S3U		S3U
S3U		S3U	1-77-2-L	CPO MESS & LOUNGE	S3U		S3U
S2I	S3U		(none)	(weather bulkhead)	S2I	S3U	
S4I			4-66-0-E	MAIN MACHINERY ROOM	S4I		
S4I			01-71-2-L	CPO WR, WC, SH	S4U		
S4I			01-74-2-L	CPO SR	S4U		
S4I			(none)	(weather overhead)	S4U		
			1-74-2-Q	DC REPAIR LKR NO. 2	(CUI = QA)		
S3U		S3U	1-66-0-L	CREW MESS	S3U		S3U
S3U		S3U	1-66-0-L	CREW MESS	S3U		S3U
S3U		S3U	1-71-2-Q	ENG LOG OFFICE & DC	S3U		S3U
S3U		S3U	1-77-2-L	CPO MESS & LOUNGE	S3U		S3U
S4I			4-66-0-E	MAIN MACHINERY ROOM	S4I		
S4U			01-71-2-L	CPO WR, WC, SH	S4U		
S4U			01-74-2-L	CPO SR	S4U		
			1-76-0-Q	MMR (UPTAKE)	(CUI = TU)		
S3U		S3U	4-82-0-E	AUXILIARY MACHINERY	S3U		S3U
S3I		S3U	1-66-0-L	CREW MESS	S3U		S3I
S3I		S3U	1-66-0-L	CREW MESS	S3U		S3I
S3U		S3U	1-66-0-L	CREW MESS	S3U		S3U
S3I		S3U	1-77-1-A	CREW LOCKER	S3U		S3I
S3U		S3I	1-80-1-E	VENT PLENUM	S3U		S3I
S3U		S3U	01-60-0A-L	PASSAGE	S3U		S3I
S3U		S3I	01-68-0-Q	SHIP OFFICE	S3U		S3I
S3U		S3U	01-74-1-L	MEDICAL TREATMENT WR	S3U		S3I
S3U		S3U	01-74-1-L	MEDICAL TREATMENT WR	S3U		S3I
S3U		S3I	01-78-1-F	EMERGENCY GEN SERVIC	S3U		S3U
S3I		S3U	01-78-3-E	EMERGENCY GENERATOR	S3U		S3I
S3I		S3U	01-79-0A-L	PASSAGE	S3U		S3I
S3I		S3U	01-79-0B-L	PASSAGE	S3U		S3I
S3U		S3I	1-80-1-Q	VENT PLENUM	S3U		S3U
S3U		S3U	1-80-1-Q	VENT PLENUM	S3U		S3U
S3U		S3U	02-73-0-Q	FAN ROOM	S3U		S3U
S3U		S3U	02-73-0-Q	FAN ROOM	S3U		S3U
S3U		S3I	02-73-0-Q	FAN ROOM	S3U		S3I
S3I		S3U	02-85-0-Q	INCINERATOR ROOM	S3U		S3I
S3U	S3U		(none)	(weather bulkhead)	S3U	S3U	
S3U	S3U		(none)	(weather bulkhead)	S3U	S3U	
000			4-66-0-E	MAIN MACHINERY ROOM	000		
S4U			4-82-0-E	AUXILIARY MACHINERY	S4U		

Table D.2 Barrier Data

Ship Visit Barrier Materials			Plan ID	Compartment Name Adjacent Compartment	Preliminary Baseline Barrier Materials		
<1>	<2>	<3>			<1>	<2>	<3>
S4U			03-76-0-Q	STACK	S4U		
			1-77-1-A	CREW LOCKER	(CUI = AG)		
S2U		S2U	1-66-0-L	CREW MESS	S2U		S2U
S3U		S3I	1-76-0-Q	MMR (UPTAKE)	S3I		S3U
S2U		NPU	1-77-3-L	CREW LOUNGE	S2U		S2U
S3U		S3I	1-80-1-E	VENT PLENUM	S3I		S3U
S4I			4-66-0-E	MAIN MACHINERY ROOM	S4I		
S4U			01-74-1-L	MEDICAL TREATMENT WR	S4U		
S4U			01-78-1-F	EMERGENCY GEN SERVIC	S4U		
			1-77-2-L	CPO MESS & LOUNGE	(CUI = LL)		
S2U		S2U	1-66-0-L	CREW MESS	S2U		S2U
S3U		S3U	1-71-2-Q	ENG LOG OFFICE & DC	S3U		S3U
S3U		S3U	1-74-2-Q	DC REPAIR LKR NO. 2	S3U		S3U
S3U		S3U	1-82-2-Q	C.G. LKR W/ SINK	S3U		S3U
S3U		S3U	1-82-4-L	CREW WR, WC & SH	S3U		S3U
S2U	S3U		(none)	(weather bulkhead)	S2I	S3U	
S4I			4-66-0-E	MAIN MACHINERY ROOM	S4I		
S4U			01-74-2-L	CPO SR	S4U		
S4U			01-80-0-L	CREW SR	S4U		
S4U			(none)	(weather overhead)	S4U		
			1-77-3-L	CREW LOUNGE	(CUI = LL)		
NSU		NPU	1-66-0-L	CREW MESS	NPU		NSU
NPU		S2U	1-77-1-A	CREW LOCKER	S2U		S2U
NPU		S3I	1-80-1-E	VENT PLENUM	S3U		S3U
S3U		S3U	1-82-1-L	CREW WR, WC & SH	S3U		S3U
S3U		S3U	1-82-3-L	CREW WR, WC & SH	S3U		S3U
S2I	S3U		(none)	(weather bulkhead)	S2I	S3U	
S4I			4-66-0-E	MAIN MACHINERY ROOM	S4I		
S4I			2-89-1-C	ENGINEERING CONTROL	S4I		
S4U			01-68-1-L	MEDICAL TREATMENT RO	S4U		
S4U			01-78-3-E	EMERGENCY GENERATOR	S4U		
S4U			(none)	(weather overhead)	S4U		
			1-80-1-E	VENT PLENUM	(CUI = TH)		
S3I		S3U	1-76-0-Q	MMR (UPTAKE)	S3I		S3U
S3I		S3U	1-77-1-A	CREW LOCKER	S3U		S3I
S3I		NPU	1-77-3-L	CREW LOUNGE	S3U		S3U
S3I		S3U	1-82-1-L	CREW WR, WC & SH	S3U		S3U
S4I			4-66-0-E	MAIN MACHINERY ROOM	S4I		
S4U			1-80-1-Q	VENT PLENUM	S4U		
			1-82-0-L	PASSAGE	(CUI = LP)		
S3U		S3U	4-82-0-E	AUXILIARY MACHINERY	S3U		S3U
S3U		S3U	1-66-0-L	CREW MESS	S3U		S3U
S3U		S3U	1-82-2-Q	C.G. LKR W/ SINK	S3U		S3U
S2U		S2U	1-84-2-L	COMPANIONWAY	S2U		S2U
S2U		S2U	1-85-1-L	CREW SR	S2U		S2U
000		000	1-85-2-Q	AFFF STA.	000		000

Table D.2 Barrier Data

Ship Visit Barrier Materials			Plan ID	Compartment Name Adjacent Compartment	Preliminary Baseline Barrier Materials		
<1>	<2>	<3>			<1>	<2>	<3>
S2U		S2U	1-85-2-Q	AFFF STA.	S2U		S2U
S2U		S2U	1-85-3-L	CREW SR	S2U		S2U
S2U		S2U	1-85-4-L	CREW SR	S2U		S2U
S3U		S3U	1-92-0-L	PASSAGE	S3U		S3U
S4I			4-82-0-E	AUXILIARY MACHINERY	S4I		
S4U			01-79-0A-L	PASSAGE	S4U		
S4U			01-88-0-L	CREW SR	S4U		
S4U			01-88-1-L	CREW WR, WC & SH	S4U		
			1-82-1-L	CREW WR, WC & SH	(CUI = LW)		
S3I		S3U	4-82-0-E	AUXILIARY MACHINERY	S3I		S3U
S3U		S3U	1-77-3-L	CREW LOUNGE	S3U		S3U
S3U		S3I	1-80-1-E	VENT PLENUM	S3U		S3U
S3U		S3U	1-82-3-L	CREW WR, WC & SH	S3U		S3U
NPU		NPU	1-85-1-L	CREW SR	NPU		NPU
NPU		NPU	1-85-3-L	CREW SR	NPU		NPU
S4I			4-82-0-E	AUXILIARY MACHINERY	S4I		
S4U			01-78-3-E	EMERGENCY GENERATOR	S4U		
			1-82-2-Q	C.G. LKR W/ SINK	(CUI = AG)		
S3U		S3U	1-77-2-L	CPO MESS & LOUNGE	S3U		S3U
S3U		S3U	1-82-0-L	PASSAGE	S3U		S3U
S3U		S3U	1-82-4-L	CREW WR, WC & SH	S3U		S3U
S2U		S2U	1-84-2-L	COMPANIONWAY	S2U		S2U
S4I			4-82-0-E	AUXILIARY MACHINERY	S4I		
S4U			01-80-0-L	CREW SR	S4U		
S4U			01-84-2-L	CREW WR, WC & SH	S4U		
			1-82-3-L	CREW WR, WC & SH	(CUI = LW)		
S3U		S3U	1-77-3-L	CREW LOUNGE	S3U		S3U
S3U		S3U	1-82-1-L	CREW WR, WC & SH	S3U		S3U
NPU		NPU	1-85-3-L	CREW SR	NPU		NPU
S2I	S3U		(none)	(weather bulkhead)	S2I	S3U	
S4I			4-82-0-E	AUXILIARY MACHINERY	S4I		
S4U			01-78-3-E	EMERGENCY GENERATOR	S4U		
S4U			(none)	(weather overhead)	S4U		
			1-82-4-L	CREW WR, WC & SH	(CUI = LW)		
S3U		S3U	1-77-2-L	CPO MESS & LOUNGE	S3U		S3U
S3U		S3U	1-82-2-Q	C.G. LKR W/ SINK	S3U		S3U
S3U		S3U	1-84-2-L	COMPANIONWAY	S3U		S3U
NPU		NPU	1-85-4-L	CREW SR	NPU		NPU
S2I	S3U		(none)	(weather bulkhead)	S2I	S3U	
S4I			4-82-0-E	AUXILIARY MACHINERY	S4I		
S4U			01-80-0-L	CREW SR	S4U		
S4U			01-84-2-L	CREW WR, WC & SH	S4U		
S4U			(none)	(weather overhead)	S4U		
			1-84-2-L	COMPANIONWAY	(CUI = LP)		
S2U		S2U	1-82-0-L	PASSAGE	S2U		S2U
S2U		S2U	1-82-2-Q	C.G. LKR W/ SINK	S2U		S2U

Table D.2 Barrier Data

Ship Visit Barrier Materials			Plan ID	Compartment Name	Preliminary Baseline Barrier Materials		
<1>	<2>	<3>			<1>	<2>	<3>
S3U		S3U	1-82-4-L	CREW WR, WC & SH	S3U		S3U
S2U		S2U	1-85-4-L	CREW SR	S2U		S2U
S2U		S2U	1-85-4-L	CREW SR	S2U		S2U
S4I			4-82-0-E	AUXILIARY MACHINERY	S4I		
S4U			01-84-2-L	CREW WR, WC & SH	S4U		
S4U			01-85-2-Q	FOUL WEATHER GEAR LK	S4U		
S4U			01-88-2-L	CREW SR	S4U		
			1-85-1-L	CREW SR	(CUI = L5)		
S3U		S3I	4-82-0-E	AUXILIARY MACHINERY	S3I		S3U
S2U		S2U	1-82-0-L	PASSAGE	S2U		S2U
NPU		NPU	1-82-1-L	CREW WR, WC & SH	NPU		NPU
S2U		S2U	1-85-2-Q	AFFF STA.	S2U		S2U
NPU		NPU	1-85-3-L	CREW SR	NPU		NPU
NPU		NPU	1-85-3-L	CREW SR	NPU		NPU
S4I			4-82-0-E	AUXILIARY MACHINERY	S4I		
S4U			01-78-3-E	EMERGENCY GENERATOR	S4U		
S4U			01-79-0B-L	PASSAGE	S4U		
S4U			01-88-0-L	CREW SR	S4U		
S4U			01-88-1-L	CREW WR, WC & SH	S4U		
			1-85-2-Q	AFFF STA.	(CUI = QA)		
S2U		S2U	4-82-0-E	AUXILIARY MACHINERY	S2U		S2U
000		000	1-82-0-L	PASSAGE	000		000
S2U		S2U	1-82-0-L	PASSAGE	S2U		S2U
S2U		S2U	1-85-1-L	CREW SR	S2U		S2U
S4I			4-82-0-E	AUXILIARY MACHINERY	S4I		
S4U			01-79-0B-L	PASSAGE	S4U		
S4U			01-88-0-L	CREW SR	S4U		
			1-85-3-L	CREW SR	(CUI = L5)		
S2U		S2U	1-82-0-L	PASSAGE	S2U		S2U
NPU		NPU	1-82-1-L	CREW WR, WC & SH	NPU		NPU
NPU		NPU	1-82-3-L	CREW WR, WC & SH	NPU		NPU
NPU		NPU	1-85-1-L	CREW SR	NPU		NPU
NPU		NPU	1-85-1-L	CREW SR	NPU		NPU
S3U		S3U	1-92-1-L	CREW SR	S3U		S3U
S2I	S3U		(none)	(weather bulkhead)	S2I	S3U	
S4I			4-82-0-E	AUXILIARY MACHINERY	S4I		
S4I			01-78-3-E	EMERGENCY GENERATOR	S4I		
S4I			01-86-1-L	CREW SR	S4I		
S4I			01-88-1-L	CREW WR, WC & SH	S4I		
S4I			(none)	(weather overhead)	S4I		
			1-85-4-L	CREW SR	(CUI = L5)		
S2U		S2U	1-82-0-L	PASSAGE	S2U		S2U
NPU		NPU	1-82-4-L	CREW WR, WC & SH	NPU		NPU
S2U		S2U	1-84-2-L	COMPANIONWAY	S2U		S2U
S2U		S2U	1-84-2-L	COMPANIONWAY	S2U		S2U
S3U		S3U	1-92-2-L	CREW SR	S3U		S3U

Table D.2 Barrier Data

Ship Visit Barrier Materials			Plan ID	Compartment Name Adjacent Compartment	Preliminary Baseline Barrier Materials		
<1>	<2>	<3>			<1>	<2>	<3>
S2I	S3U		(none)	(weather bulkhead)	S2I	S3U	
S4I			4-82-0-E	AUXILIARY MACHINERY	S4I		
S4U			01-84-2-L	CREW WR, WC & SH	S4U		
S4U			01-88-2-L	CREW SR	S4U		
S4U			(none)	(weather overhead)	S4U		
			1-92-0-L	PASSAGE	(CUI = LP)		
S3U		S3U	1-82-0-L	PASSAGE	S3U		S3U
S2U		S2U	1-92-1-L	CREW SR	S2U		S2U
S2U		S2U	1-92-2-L	CREW SR	S2U		S2U
S2U		S2U	1-96-0-L	CREW SR	S2U		S2U
S2U		S2U	1-96-0-L	CREW SR	S2U		S2U
S2U		S2U	1-96-1-L	CREW WR, WC & SH	S2U		S2U
S3U		S3I	1-97-2-Q	FAN ROOM	S3U		S3U
S3U		S3I	1-102-2-A	DECK GEAR STOREROOM	S3I		S3U
S4I			4-92-0-E	STERN THRUSTER MACHR	S4I		
S4U			01-79-0A-L	PASSAGE	S4U		
S4I			01-92-0-L	COMPANIONWAY	S4I		
S4I			(none)	(weather overhead)	S4I		
			1-92-1-L	CREW SR	(CUI = L5)		
S3U		S3U	1-85-3-L	CREW SR	S3U		S3U
S2U		S2U	1-92-0-L	PASSAGE	S2U		S2U
NPU		NPU	1-96-1-L	CREW WR, WC & SH	NPU		NPU
NPU		NPU	1-96-1-L	CREW WR, WC & SH	NPU		NPU
NPU		NPU	1-98-1-L	CREW WR, WC & SH	NPU		NPU
S2I	S3U		(none)	(weather bulkhead)	S2I	S3U	
S4I			4-92-0-E	STERN THRUSTER MACHR	S4I		
S4U			(none)	(weather overhead)	S4U		
			1-92-2-L	CREW SR	(CUI = L5)		
S3U		S3U	1-85-4-L	CREW SR	S3U		S3U
S2U		S2U	1-92-0-L	PASSAGE	S2U		S2U
S3U		S3I	1-97-2-Q	FAN ROOM	NPU		S3U
NPU		NPU	1-97-4-L	CREW WR, WC & SH	NPU		NPU
S2I	S3U		(none)	(weather bulkhead)	S2I	S3U	
S4I			4-92-0-E	STERN THRUSTER MACHR	S4I		
S4I			(none)	(weather overhead)	S4I		
			1-96-0-L	CREW SR	(CUI = L5)		
S2U		S2U	1-92-0-L	PASSAGE	S2U		S2U
S2U		S2U	1-92-0-L	PASSAGE	S2U		S2U
NPU		NPU	1-96-1-L	CREW WR, WC & SH	NPU		NPU
S3U		S3I	1-102-0-E	STEERING GEAR ROOM	S3I		S3U
S4I			4-92-0-E	STERN THRUSTER MACHR	S4I		
S4I			(none)	(weather overhead)	S4I		
			1-96-1-L	CREW WR, WC & SH	(CUI = LW)		
S2U		S2U	1-92-0-L	PASSAGE	S2U		S2U
NPU		NPU	1-92-1-L	CREW SR	NPU		NPU
NPU		NPU	1-92-1-L	CREW SR	NPU		NPU

Table D.2 Barrier Data

Ship Visit Barrier Materials			Plan ID	Compartment Name Adjacent Compartment	Preliminary Baseline Barrier Materials		
<1>	<2>	<3>			<1>	<2>	<3>
NPU		NPU	1-96-0-L	CREW SR	NPU		NPU
NPU		NPU	1-98-1-L	CREW WR, WC & SH	NPU		NPU
S3U		S3I	1-102-0-E	STEERING GEAR ROOM	S3I		S3U
S4I			4-92-0-E	STERN THRUSTER MACHR	S4I		
S4I			(none)	(weather overhead)	S4I		
			1-97-2-Q	FAN ROOM	(CUI = QF)		
S3I		S3U	1-92-0-L	PASSAGE	S3U		S3U
S3I		S3U	1-92-2-L	CREW SR	S3U		NPU
S3I		S3U	1-97-4-L	CREW WR, WC & SH	S3U		NPI
S3I		S3I	1-102-2-A	DECK GEAR STOREROOM	S3U		S3U
S4I			(none)	(weather overhead)	S4I		
			1-97-4-L	CREW WR, WC & SH	(CUI = LW)		
NPU		NPU	1-92-2-L	CREW SR	NPU		NPU
S3U		S3I	1-97-2-Q	FAN ROOM	NPI		S3U
S3U		S3I	1-102-2-A	DECK GEAR STOREROOM	NPI		S3U
S2I	S3U		(none)	(weather bulkhead)	S2I	S3U	
S4I			(none)	(weather overhead)	S4I		
			1-98-1-L	CREW WR, WC & SH	(CUI = LW)		
NPU		NPU	1-92-1-L	CREW SR	NPU		NPU
NPU		NPU	1-96-1-L	CREW WR, WC & SH	NPU		NPU
S3U		S3I	1-102-0-E	STEERING GEAR ROOM	S3I		S3U
S2I	S3U		(none)	(weather bulkhead)	S2I	S3U	
S4I			(none)	(weather overhead)	S4I		
			1-102-0-E	STEERING GEAR ROOM	(CUI = EM)		
S3I		S3U	1-96-0-L	CREW SR	S3U		S3I
S3I		S3U	1-96-1-L	CREW WR, WC & SH	S3U		S3I
S3I		S3U	1-98-1-L	CREW WR, WC & SH	S3U		S3I
S3U		S3I	1-102-2-A	DECK GEAR STOREROOM	S3U		S3U
S3U		S3I	1-105-2-Q	LAUNDRY	S3U		S3U
S2I	S3U		(none)	(weather bulkhead)	S2U	S3U	
S2I	S3U		(none)	(weather bulkhead)	S2U	S3U	
S2I	S3U		(none)	(weather bulkhead)	S2U	S3U	
S4I			(none)	(weather overhead)	S4U		
			1-102-2-A	DECK GEAR STOREROOM	(CUI = AS)		
S3I		S3U	1-92-0-L	PASSAGE	S3U		S3I
S3I		S3I	1-97-2-Q	FAN ROOM	S3U		S3U
S3I		S3U	1-97-4-L	CREW WR, WC & SH	S3U		NPI
S3I		S3U	1-102-0-E	STEERING GEAR ROOM	S3U		S3U
S3U		S3I	1-105-2-Q	LAUNDRY	S3U		S3U
S2I	S3U		(none)	(weather bulkhead)	S2I	S3U	
S4I			(none)	(weather overhead)	S4I		
			1-105-2-Q	LAUNDRY	(CUI = QL)		
S3I		S3U	1-102-0-E	STEERING GEAR ROOM	S3U		S3U
S3I		S3U	1-102-2-A	DECK GEAR STOREROOM	S3U		S3U
S2I	S3U		(none)	(weather bulkhead)	S2I	S3U	
S2I	S3U		(none)	(weather bulkhead)	S2I	S3U	

Table D.2 Barrier Data

Ship Visit Barrier Materials			Plan ID	Compartment Name Adjacent Compartment	Preliminary Baseline Barrier Materials		
<1>	<2>	<3>			<1>	<2>	<3>
S4I			(none)	(weather overhead)	S4I		
			01-27-0-C	BUOY DECK CONTROL BOOTH	(CUI = C)		
S3U	S3U		(none)	(weather bulkhead)	S3U	S3U	
S3U	S3U		(none)	(weather bulkhead)	S3U	S3U	
S3U	S3U		(none)	(weather bulkhead)	S3U	S3U	
S3U	S3U		(none)	(weather bulkhead)	S3U	S3U	
S4U			3-23-0-Q	CRANE PEDESTAL	S4U		
S4U			(none)	(weather overhead)	S4U		
			01-57-0-Q	WARD ROOM PANTRY	(CUI = QG)		
S3I		S3U	1-57-3-Q	DUMBWAITER TRUNK	S3I		S3U
S3I		S3U	1-57-3-Q	DUMBWAITER TRUNK	S3I		S3U
S3I		S3U	1-57-3-Q	DUMBWAITER TRUNK	S3I		S3U
S3U		S3U	01-57-2-L	CPO SR	S3U		S3U
S3U		S3U	01-60-0C-L	PASSAGE	S3U		S3U
S3U		S3U	01-60-1-L	WARDROOM MESSROOM &	S3U		S3U
S3I	S3U		(none)	(weather bulkhead)	S3I	S3U	
S3I	S3U		(none)	(weather bulkhead)	S3I	S3U	
S3I	S3U		(none)	(weather bulkhead)	S3I	S3U	
S4U			1-57-0-L	DECK WR & WC	S4U		
S4U			1-57-1-Q	GALLEY	S4U		
S4U			1-59-2-L	COMPANIONWAY	S4U		
S4U			02-57-0-L	CO CABIN	S4U		
S4U			02-57-1-L	CO SR	S4U		
S4U			02-59-2-L	COMPANIONWAY	S4U		
			01-57-2-L	CPO SR	(CUI = L2)		
S3U		S3U	01-57-0-Q	WARD ROOM PANTRY	S3U		S3U
NPU		S2U	01-57-4-L	CPO WR, WC, SH	NPU		NPU
S2U		S2U	01-60-0C-L	PASSAGE	S2U		S2U
S3U		S3U	01-60-0C-L	PASSAGE	S3U		S3U
NPU		S2U	01-83-2-L	CPO SR	NPU		NPU
S3I	S3U		(none)	(weather bulkhead)	S3I	S3U	
S4U			1-57-0-L	DECK WR & WC	S4U		
S4U			1-57-2-L	PASSAGE	S4U		
S4U			1-57-4-Q	CHANGE ROOM	S4U		
S4U			1-59-2-L	COMPANIONWAY	S4U		
S4I			1-60-2-A	CHILL STRM	S4U		
S4U			02-57-0-L	CO CABIN	S4U		
S4U			02-57-0C-L	PASSAGE	S4U		
S4U			02-57-2-L	XO WR, WC, SH	S4U		
S4U			02-57-4-L	XO SR	S4U		
S4U			02-59-2-L	COMPANIONWAY	S4U		
			01-57-4-L	CPO WR, WC, SH	(CUI = LW)		
S2U		NPU	01-57-2-L	CPO SR	NPU		NPU
S2U		S2U	01-83-2-L	CPO SR	NPU		NPU
S3I	S3U		(none)	(weather bulkhead)	S3I	S3U	
S3I	S3U		(none)	(weather bulkhead)	S3I	S3U	

Table D.2 Barrier Data

Ship Visit Barrier Materials			Plan ID	Compartment Name Adjacent Compartment	Preliminary Baseline Barrier Materials		
<1>	<2>	<3>			<1>	<2>	<3>
S4U			1-57-4-Q	CHANGE ROOM	S4U		
S4I			1-60-2-A	CHILL STRM	S4U		
S4I			1-60-4-A	FREEZE STRM	S4U		
S4U			02-57-2-L	XO WR, WC, SH	S4U		
S4U			02-57-4-L	XO SR	S4U		
			01-60-0A-L	PASSAGE	(CUI = LP)		
S3U		S3U	1-76-0-Q	MMR (UPTAKE)	S3I		S3U
000		000	01-60-0B-L	PASSAGE	000		000
S2U		S2U	01-66-2-L	PASSAGE	S2U		S2U
S2U		S2U	01-68-0-Q	SHIP OFFICE	S2U		S2U
S2U		S2U	01-71-2-L	CPO WR, WC, SH	S2U		S2U
S2U		S2U	01-74-2-L	CPO SR	S2U		S2U
S2U		S2U	01-79-0A-L	PASSAGE	NPU		NPU
S4U			1-66-0-L	CREW MESS	S4U		
S4U			02-57-0A-L	PASSAGE	S4U		
S4U			02-57-0C-L	PASSAGE	S4U		
S4U			02-73-0-Q	FAN ROOM	S4U		
S4U			(none)	(weather overhead)	S4U		
			01-60-0B-L	PASSAGE	(CUI = LP)		
000		000	01-60-0A-L	PASSAGE	000		000
000		000	01-60-0C-L	PASSAGE	000		000
S2U		S2U	01-60-1-L	WARDROOM MESSROOM &	S2U		S2U
S2U		S2U	01-66-2-L	PASSAGE	S2U		S2U
S2U		S2U	01-68-0-Q	SHIP OFFICE	S2U		S2U
NSU		S2U	01-68-1-L	MEDICAL TREATMENT RO	S2U		NSU
S2U		S2U	01-83-2-L	CPO SR	S2U		S2U
S3I	S3U		(none)	(weather bulkhead)	S3I	S3U	
S4U			1-66-0-L	CREW MESS	S4U		
S4U			1-66-1-Q	GALLEY ANNEX	S4U		
S4U			1-66-3-Q	SCULLERY	S4U		
S4U			02-57-0C-L	PASSAGE	S4U		
S4U			02-61-2-L	COMPANIONWAY	S4U		
S4U			02-66-0-C	RADIO ROOM	S4U		
S4U			02-66-1-L	OFFICER WR, WC, SH	S4U		
			01-60-0C-L	PASSAGE	(CUI = LP)		
S3U		S3U	01-57-0-Q	WARD ROOM PANTRY	S3U		S3U
S2U		S2U	01-57-2-L	CPO SR	S2U		S2U
S3U		S3U	01-57-2-L	CPO SR	S3U		S3U
000		000	01-60-0B-L	PASSAGE	000		000
S2U		S2U	01-60-1-L	WARDROOM MESSROOM &	S2U		S2U
S2U		S2U	01-83-2-L	CPO SR	S2U		S2U
S4U			1-57-2-L	PASSAGE	S4U		
S4U			1-59-2-L	COMPANIONWAY	S4U		
S4U			02-57-0C-L	PASSAGE	S4U		
S4U			02-59-2-L	COMPANIONWAY	S4U		
S4U			02-61-2-L	COMPANIONWAY	S4U		

Table D.2 Barrier Data

Ship Visit Barrier Materials			Plan ID	Compartment Name Adjacent Compartment	Preliminary Baseline Barrier Materials		
<1>	<2>	<3>			<1>	<2>	<3>
			01-60-1-L	WARDROOM MESSROOM & LOUNGE	(CUI = LL)		
S3U		S3U	01-57-0-Q	WARD ROOM PANTRY	S3U		S3U
S2U		S2U	01-60-0B-L	PASSAGE	S2U		S2U
S2U		S2U	01-60-0C-L	PASSAGE	S2U		S2U
S3I	S3U		(none)	(weather bulkhead)	S3I	S3U	
S4U			1-57-1-Q	GALLEY	S4U		
S4U			1-60-1-L	GALLEY WR & WC	S4U		
S4U			02-57-0-L	CO CABIN	S4U		
S4U			02-57-1-L	CO SR	S4U		
S4U			02-63-1-L	CO WR, WC, SH	S4U		
			01-66-2-L	PASSAGE	(CUI = LP)		
S2U		S2U	01-60-0A-L	PASSAGE	S2U		S2U
S2U		S2U	01-60-0B-L	PASSAGE	S2U		S2U
S2U		S2U	01-70-2-Q	C.G. LKR	S2U		S2U
S2U		S2U	01-70-2-Q	C.G. LKR	S2U		S2U
S2U		S2U	01-71-2-L	CPO WR, WC, SH	S2U		S2U
S2U		S2U	01-83-2-L	CPO SR	S2U		S2U
S3I	S3U		(none)	(weather bulkhead)	S3I	S3U	
S4I			1-60-6A-A	DRY PROVISION STORER	S4U		
S4U			1-66-0-L	CREW MESS	S4U		
S4I			1-66-2-L	COMPANIONWAY	S4U		
S4U			02-66-2-L	OFFICER WR, WC, SH	S4U		
S4U			02-66-4-L	OFFICER WR, WC, SH	S4U		
S4U			02-69-2-Q	CG LKR W/SINK	S4U		
S4U			02-69-4-L	OFFICER SR	S4U		
			01-68-0-Q	SHIP OFFICE	(CUI = QO)		
S3I		S3U	1-76-0-Q	MMR (UPTAKE)	S3I		S3U
S2U		S2U	01-60-0A-L	PASSAGE	S2U		S2U
S2U		S2U	01-60-0B-L	PASSAGE	S2U		S2U
NPU		S2U	01-68-1-L	MEDICAL TREATMENT RO	NSU		NPU
NPU		NPU	01-74-1-L	MEDICAL TREATMENT WR	NPU		NPU
S3U		S3U	01-74-1-L	MEDICAL TREATMENT WR	S3U		S3U
S4U			1-66-0-L	CREW MESS	S4U		
S4U			1-66-1-Q	GALLEY ANNEX	S4U		
S4U			02-57-0A-L	PASSAGE	S4U		
S4U			02-66-0-C	RADIO ROOM	S4U		
S4U			02-73-0-Q	FAN ROOM	S4U		
			01-68-1-L	MEDICAL TREATMENT ROOM	(CUI = LM)		
S2U		NSU	01-60-0B-L	PASSAGE	NSU		S2U
S2U		NPU	01-68-0-Q	SHIP OFFICE	NPU		NSU
S2U		NPU	01-74-1-L	MEDICAL TREATMENT WR	NPU		NPU
S2U		NSU	01-74-1-L	MEDICAL TREATMENT WR	NSU		NPU
S3I		S3U	01-78-3-E	EMERGENCY GENERATOR	S3U		S3I
S2I	S3U		(none)	(weather bulkhead)	NSU	S3U	
S4U			1-66-0-L	CREW MESS	S4U		
S4U			1-66-1-Q	GALLEY ANNEX	S4U		

Table D.2 Barrier Data

Ship Visit Barrier Materials			Plan ID	Compartment Name Adjacent Compartment	Preliminary Baseline Barrier Materials		
<1>	<2>	<3>			<1>	<2>	<3>
S4U			1-66-3-Q	SCULLERY	S4U		
S4U			1-77-3-L	CREW LOUNGE	S4U		
S4U			02-57-0A-L	PASSAGE	S4U		
S4U			02-57-0B-L	PASSAGE	S4U		
S4U			02-66-0-C	RADIO ROOM	S4U		
S4U			02-66-1-L	OFFICER WR, WC, SH	S4U		
S4U			02-69-1-L	OFFICER SR	S4U		
S4U			02-73-0-Q	FAN ROOM	S4U		
S4U			02-75-1-Q	PFD & SURVIVAL SUIT	S4U		
S4U			(none)	(weather overhead)	S4U		
			01-70-2-Q	C.G. LKR	(CUI = AG)		
S2U		S2U	01-66-2-L	PASSAGE	S2U		S2U
S2U		S2U	01-66-2-L	PASSAGE	S2U		S2U
S2U		S2U	01-71-2-L	CPO WR, WC, SH	S2U		S2U
S3I	S3U		(none)	(weather bulkhead)	S3I	S3U	
S4I			1-60-6A-A	DRY PROVISION STORER	S4U		
S4I			1-66-2-L	COMPANIONWAY	S4U		
S4U			02-69-4-L	OFFICER SR	S4U		
			01-71-2-L	CPO WR, WC, SH	(CUI = LW)		
S2U		S2U	01-60-0A-L	PASSAGE	S2U		S2U
S2U		S2U	01-66-2-L	PASSAGE	S2U		S2U
S2U		S2U	01-70-2-Q	C.G. LKR	S2U		S2U
NPU		NPU	01-74-2-L	CPO SR	NPU		NPU
S3I	S3U		(none)	(weather bulkhead)	S3I	S3U	
S4U			1-66-0-L	CREW MESS	S4U		
S4I			1-71-2-Q	ENG LOG OFFICE & DC	S4U		
S4U			1-74-2-Q	DC REPAIR LKR NO. 2	S4U		
S4U			02-57-0A-L	PASSAGE	S4U		
S4U			02-69-4-L	OFFICER SR	S4U		
S4U			02-73-0-Q	FAN ROOM	S4U		
			01-74-1-L	MEDICAL TREATMENT WR, WC & SH	(CUI = LW)		
S3U		S3U	1-76-0-Q	MMR (UPTAKE)	S3I		S3U
S3U		S3U	1-76-0-Q	MMR (UPTAKE)	S3I		S3U
NPU		NPU	01-68-0-Q	SHIP OFFICE	NPU		NPU
S3U		S3U	01-68-0-Q	SHIP OFFICE	S3U		S3U
NPU		S2U	01-68-1-L	MEDICAL TREATMENT RO	NPU		NPU
NSU		S2U	01-68-1-L	MEDICAL TREATMENT RO	NPU		NSU
S3U		S3I	01-78-1-F	EMERGENCY GEN SERVIC	S3I		S3U
S4U			1-66-0-L	CREW MESS	S4U		
S4U			1-77-1-A	CREW LOCKER	S4U		
S4U			02-73-0-Q	FAN ROOM	S4U		
			01-74-2-L	CPO SR	(CUI = L2)		
S2U		S2U	01-60-0A-L	PASSAGE	S2U		S2U
NPU		NPU	01-71-2-L	CPO WR, WC, SH	NPU		NPU
S3U		S3U	01-79-0A-L	PASSAGE	S3U		S3U
NPU		NPU	01-80-0-L	CREW SR	NPU		NPU

Table D.2 Barrier Data

Ship Visit Barrier Materials			Plan ID	Compartment Name	Preliminary Baseline Barrier Materials		
<1>	<2>	<3>			Adjacent Compartment	<1>	<2>
S3I	S3U		(none)	(weather bulkhead)	S3I	S3U	
S4I			1-71-2-Q	ENG LOG OFFICE & DC	S4U		
S4U			1-74-2-Q	DC REPAIR LKR NO. 2	S4U		
S4U			1-77-2-L	CPO MESS & LOUNGE	S4U		
S4I			02-69-4-L	OFFICER SR	S4I		
S4I			02-73-0-Q	FAN ROOM	S4I		
S4I			02-75-2-Q	PFD & SURVIVAL SUIT	S4I		
S4I			(none)	(weather overhead)	S4I		
			01-78-1-F	EMERGENCY GEN SERVICE TK	(CUI = QE)		
S3I		S3U	1-76-0-Q	MMR (UPTAKE)	S3U		S3U
S3I		S3U	01-74-1-L	MEDICAL TREATMENT WR	S3U		S3I
S3I		S3U	01-78-3-E	EMERGENCY GENERATOR	S3U		S3I
S3I		S3U	1-80-1-Q	VENT PLENUM	S3U		S3U
S4U			1-77-1-A	CREW LOCKER	S4U		
S4U			02-73-0-Q	FAN ROOM	S4U		
			01-78-3-E	EMERGENCY GENERATOR ROOM	(CUI = QE)		
S3U		S3I	1-76-0-Q	MMR (UPTAKE)	S3I		S3U
S3U		S3I	01-68-1-L	MEDICAL TREATMENT RO	S3I		S3U
S3U		S3I	01-78-1-F	EMERGENCY GEN SERVIC	S3I		S3U
S3U		S3I	01-79-0B-L	PASSAGE	S3I		S3U
S3U		S3I	01-79-0B-L	PASSAGE	S3I		S3U
S3U		S3I	1-80-1-Q	VENT PLENUM	S3I		S3U
S3U		S3I	1-80-1-Q	VENT PLENUM	S3I		S3U
S3U		S3I	01-86-1-L	CREW SR	S3I		S3U
S3I	S3U		(none)	(weather bulkhead)	S3I	S3U	
S4U			1-77-3-L	CREW LOUNGE	S4U		
S4U			1-82-1-L	CREW WR, WC & SH	S4U		
S4U			1-82-3-L	CREW WR, WC & SH	S4U		
S4U			1-85-1-L	CREW SR	S4U		
S4I			1-85-3-L	CREW SR	S4I		
S4I			02-85-0-Q	INCINERATOR ROOM	S4I		
S4I			(none)	(weather overhead)	S4I		
			01-79-0A-L	PASSAGE	(CUI = LP)		
S3U		S3I	1-76-0-Q	MMR (UPTAKE)	S3I		S3U
S2U		S2U	01-60-0A-L	PASSAGE	NPU		NPU
S3U		S3U	01-74-2-L	CPO SR	S3U		S3U
000		000	01-79-0B-L	PASSAGE	000		000
S2U		S2U	01-80-0-L	CREW SR	S2U		S2U
S2U		S2U	01-84-2-L	CREW WR, WC & SH	S2U		S2U
S2U		S2U	01-85-2-Q	FOUL WEATHER GEAR LK	S2U		S2U
S2U		S2U	01-88-0-L	CREW SR	S2U		S2U
S3U		S3U	01-88-0-L	CREW SR	S3U		S3U
S2U		S2U	01-88-2-L	CREW SR	S2U		S2U
S2U		S2U	01-92-0-L	COMPANIONWAY	S2U		S2U
S3I	S3U		(none)	(weather bulkhead)	S3I	S3U	
S3I	S3U		(none)	(weather bulkhead)	S3I	S3U	

Table D.2 Barrier Data

Ship Visit Barrier Materials			Plan ID	Compartment Name Adjacent Compartment	Preliminary Baseline Barrier Materials		
<1>	<2>	<3>			<1>	<2>	<3>
S4U			1-66-0-L	CREW MESS	S4U		
S4U			1-82-0-L	PASSAGE	S4U		
S4U			1-92-0-L	PASSAGE	S4U		
S4I			02-85-0-Q	INCINERATOR ROOM	S4I		
S4I			(none)	(weather overhead)	S4I		
			01-79-0B-L	PASSAGE	(CUI = LP)		
S3U		S3I	1-76-0-Q	MMR (UPTAKE)	S3I		S3U
S3I		S3U	01-78-3-E	EMERGENCY GENERATOR	S3U		S3I
S3I		S3U	01-78-3-E	EMERGENCY GENERATOR	S3U		S3I
000		000	01-79-0A-L	PASSAGE	000		000
S2U		S2U	01-86-1-L	CREW SR	S2U		S2U
S2U		S2U	01-88-0-L	CREW SR	S2U		S2U
S2U		S2U	01-88-1-L	CREW WR, WC & SH	S2U		S2U
S4U			1-85-1-L	CREW SR	S4U		
S4U			1-85-2-Q	AFFF STA.	S4U		
S4I			02-85-0-Q	INCINERATOR ROOM	S4I		
S4I			(none)	(weather overhead)	S4I		
			01-80-0-L	CREW SR	(CUI = L2)		
NPU		NPU	01-74-2-L	CPO SR	NPU		NPU
S2U		S2U	01-79-0A-L	PASSAGE	S2U		S2U
S3U		S3U	01-84-2-L	CREW WR, WC & SH	S3U		S3U
S3I	S3U		(none)	(weather bulkhead)	S3I	S3U	
S4U			1-77-2-L	CPO MESS & LOUNGE	S4U		
S4U			1-82-2-Q	C.G. LKR W/ SINK	S4U		
S4U			1-82-4-L	CREW WR, WC & SH	S4U		
S4I			(none)	(weather overhead)	S4I		
			1-80-1-Q	VENT PLENUM	(CUI = TH)		
S3I		S3U	1-76-0-Q	MMR (UPTAKE)	S3U		S3U
S3U		S3U	1-76-0-Q	MMR (UPTAKE)	S3U		S3U
S3U		S3I	01-78-1-F	EMERGENCY GEN SERVIC	S3U		S3U
S3I		S3U	01-78-3-E	EMERGENCY GENERATOR	S3U		S3I
S3I		S3U	01-78-3-E	EMERGENCY GENERATOR	S3U		S3I
S3U		S3I	02-73-0-Q	FAN ROOM	S3U		S3I
S3U	S3U		(none)	(weather bulkhead)	S3U	S3U	
S3U	S3U		(none)	(weather bulkhead)	S3U	S3U	
S4U			1-80-1-E	VENT PLENUM	S4U		
S4U			03-76-0-Q	STACK	S4U		
S4U			(none)	(weather overhead)	S4U		
			01-83-2-L	CPO SR	(CUI = L2)		
S2U		NPU	01-57-2-L	CPO SR	NPU		NPU
S2U		S2U	01-57-4-L	CPO WR, WC, SH	NPU		NPU
S2U		S2U	01-60-0B-L	PASSAGE	S2U		S2U
S2U		S2U	01-60-0C-L	PASSAGE	S2U		S2U
S2U		S2U	01-66-2-L	PASSAGE	S2U		S2U
S3I	S3U		(none)	(weather bulkhead)	S3I	S3U	
S4U			1-57-2-L	PASSAGE	S4U		

Table D.2 Barrier Data

Ship Visit Barrier Materials			Plan ID	Compartment Name Adjacent Compartment	Preliminary Baseline Barrier Materials		
<1>	<2>	<3>			<1>	<2>	<3>
S4I			1-60-2-A	CHILL STRM	S4U		
S4I			1-60-4-A	FREEZE STRM	S4U		
S4I			1-60-6B-A	DRY PROVISION STORER	S4U		
S4U			02-57-0C-L	PASSAGE	S4U		
S4U			02-63-2-L	OFFICER SR	S4U		
			01-84-2-L	CREW WR, WC & SH	(CUI = LW)		
S2U		S2U	01-79-0A-L	PASSAGE	S2U		S2U
S3U		S3U	01-80-0-L	CREW SR	S3U		S3U
S2U		S2U	01-85-2-Q	FOUL WEATHER GEAR LK	S2U		S2U
S2U		S2U	01-85-2-Q	FOUL WEATHER GEAR LK	S2U		S2U
S2U		S2U	01-88-2-L	CREW SR	S2U		S2U
S3I	S3U		(none)	(weather bulkhead)	S3I	S3U	
S4U			1-82-2-Q	C.G. LKR W/ SINK	S4U		
S4U			1-82-4-L	CREW WR, WC & SH	S4U		
S4U			1-84-2-L	COMPANIONWAY	S4U		
S4U			1-85-4-L	CREW SR	S4U		
S4I			(none)	(weather overhead)	S4I		
			01-85-2-Q	FOUL WEATHER GEAR LKR	(CUI = AG)		
S2U		S2U	01-79-0A-L	PASSAGE	S2U		S2U
S2U		S2U	01-84-2-L	CREW WR, WC & SH	S2U		S2U
S2U		S2U	01-84-2-L	CREW WR, WC & SH	S2U		S2U
S3U		S3U	01-88-2-L	CREW SR	S3U		S3U
S4U			1-84-2-L	COMPANIONWAY	S4U		
S4I			(none)	(weather overhead)	S4I		
			01-86-1-L	CREW SR	(CUI = L2)		
S3I		S3U	01-78-3-E	EMERGENCY GENERATOR	S3U		S3I
S2U		S2U	01-79-0B-L	PASSAGE	S2U		S2U
S2U		S2I	01-88-1-L	CREW WR, WC & SH	NPU		NPU
S3I	S3U		(none)	(weather bulkhead)	NPI	S3U	
S3I	S3U		(none)	(weather bulkhead)	S3I	S3U	
S4I			1-85-3-L	CREW SR	S4I		
S4I			(none)	(weather overhead)	S4I		
			01-88-0-L	CREW SR	(CUI = L2)		
S2U		S2U	01-79-0A-L	PASSAGE	S2U		S2U
S3U		S3U	01-79-0A-L	PASSAGE	S3U		S3U
S2U		S2U	01-79-0B-L	PASSAGE	S2U		S2U
S2U		S2I	01-88-1-L	CREW WR, WC & SH	NPU		NPU
S3U		S3U	01-92-0-L	COMPANIONWAY	S3U		S3U
S4U			1-82-0-L	PASSAGE	S4U		
S4U			1-85-1-L	CREW SR	S4U		
S4U			1-85-2-Q	AFF STA.	S4U		
S4I			02-85-0-Q	INCINERATOR ROOM	S4I		
S4I			(none)	(weather overhead)	S4I		
			01-88-1-L	CREW WR, WC & SH	(CUI = LW)		
S2U		S2U	01-79-0B-L	PASSAGE	S2U		S2U
S2I		S2U	01-86-1-L	CREW SR	NPU		NPU

Table D.2 Barrier Data

Ship Visit Barrier Materials			Plan ID	Compartment Name Adjacent Compartment	Preliminary Baseline Barrier Materials		
<1>	<2>	<3>			<1>	<2>	<3>
S2I		S2U	01-88-0-L	CREW SR	NPU		NPU
S3I		S3U	01-92-0-L	COMPANIONWAY	S3U		S3U
NPI	S3U		(none)	(weather bulkhead)	NPI	S3U	
S4U			1-82-0-L	PASSAGE	S4U		
S4U			1-85-1-L	CREW SR	S4U		
S4I			1-85-3-L	CREW SR	S4I		
S4I			02-85-0-Q	INCINERATOR ROOM	S4I		
S4I			(none)	(weather overhead)	S4I		
			01-88-2-L	CREW SR	(CUI = L2)		
S2U		S2U	01-79-0A-L	PASSAGE	S2U		S2U
S2U		S2U	01-84-2-L	CREW WR, WC & SH	S2U		S2U
S3U		S3U	01-85-2-Q	FOUL WEATHER GEAR LK	S3U		S3U
S3I	S3U		(none)	(weather bulkhead)	S3I	S3U	
S3I	S3U		(none)	(weather bulkhead)	S3I	S3U	
S4U			1-84-2-L	COMPANIONWAY	S4U		
S4U			1-85-4-L	CREW SR	S4U		
S4I			(none)	(weather overhead)	S4I		
			01-92-0-L	COMPANIONWAY	(CUI = LP)		
S2U		S2U	01-79-0A-L	PASSAGE	S2U		S2U
S3U		S3U	01-88-0-L	CREW SR	S3U		S3U
S3U		S3I	01-88-1-L	CREW WR, WC & SH	S3U		S3U
S3I	S3U		(none)	(weather bulkhead)	S3I	S3U	
S3I	S3U		(none)	(weather bulkhead)	S3I	S3U	
S4I			1-92-0-L	PASSAGE	S4I		
S4I			(none)	(weather overhead)	S4U		
			02-57-0-L	CO CABIN	(CUI = L1)		
S2U		S2U	02-57-0C-L	PASSAGE	S2U		S2U
NPU		NPU	02-57-1-L	CO SR	NPU		NPU
S2U		S2U	02-59-2-L	COMPANIONWAY	S2U		S2U
S2U		S2U	02-59-2-L	COMPANIONWAY	S2U		S2U
S2U		S2U	02-61-2-L	COMPANIONWAY	S2U		S2U
NPU		S2U	02-63-1-L	CO WR, WC, SH	NPU		NPU
S3I		S3U	02-66-0-C	RADIO ROOM	S3U		S3I
S3I	S3U		(none)	(weather bulkhead)	S3I	S3U	
S4U			1-57-3-Q	DUMBWAITER TRUNK	S4U		
S4U			01-57-0-Q	WARD ROOM PANTRY	S4U		
S4U			01-57-2-L	CPO SR	S4U		
S4U			01-60-1-L	WARDROOM MESSROOM &	S4U		
S4U			03-56-0A-C	PILOT HOUSE	S4U		
S4U			03-56-0B-C	PILOT HOUSE (CHART A	S4U		
			02-57-0A-L	PASSAGE	(CUI = LP)		
000		000	02-57-0B-L	PASSAGE	000		000
000		000	02-57-0C-L	PASSAGE	000		000
S3U		S3U	02-66-0-C	RADIO ROOM	S3U		S3U
S2U		S2I	02-69-1-L	OFFICER SR	S2U		S2U
S2U		S2U	02-69-2-Q	CG LKR W/SINK	S2U		S2U

Table D.2 Barrier Data

Ship Visit Barrier Materials			Plan ID	Compartment Name Adjacent Compartment	Preliminary Baseline Barrier Materials		
<1>	<2>	<3>			<1>	<2>	<3>
S3U		S3U	02-69-4-L	OFFICER SR	S3U		S3U
S3U		S3I	02-73-0-Q	FAN ROOM	S3U		S3U
S4U			01-60-0A-L	PASSAGE	S4U		
S4U			01-68-0-Q	SHIP OFFICE	S4U		
S4U			01-68-1-L	MEDICAL TREATMENT RO	S4U		
S4U			01-71-2-L	CPO WR, WC, SH	S4U		
S4I			03-56-0A-C	PILOT HOUSE	S4I		
S4I			03-56-0B-C	PILOT HOUSE (CHART A	S4I		
S4I			03-66-01-C	ELEX, IC & GYRO ROOM	S4I		
			02-57-0B-L	PASSAGE	(CUI = LP)		
000		000	02-57-0A-L	PASSAGE	000		000
S2U		S2U	02-69-1-L	OFFICER SR	S2U		S2U
S3U		S3I	02-73-0-Q	FAN ROOM	S3U		S3U
S3U		S3U	02-75-1-Q	PFD & SURVIVAL SUIT	S3U		S3U
S3U	S3U		(none)	(weather bulkhead)	S3I	S3U	
S4U			01-68-1-L	MEDICAL TREATMENT RO	S4U		
S4I			(none)	(weather overhead)	S4U		
			02-57-0C-L	PASSAGE	(CUI = LP)		
S2U		S2U	02-57-0-L	CO CABIN	S2U		S2U
000		000	02-57-0A-L	PASSAGE	000		000
S2U		S2U	02-57-2-L	XO WR, WC, SH	S2U		S2U
S2U		S2U	02-57-4-L	XO SR	S2U		S2U
S2U		S2U	02-59-2-L	COMPANIONWAY	S2U		S2U
S2U		S2U	02-61-2-L	COMPANIONWAY	S2U		S2U
S2U		S2U	02-63-2-L	OFFICER SR	S2U		S2U
S3U		S3U	02-66-0-C	RADIO ROOM	S3U		S3U
S2U		S2U	02-66-2-L	OFFICER WR, WC, SH	S2U		S2U
S2U		S2U	02-69-2-Q	CG LKR W/SINK	S2U		S2U
S3I	S3U		(none)	(weather bulkhead)	S3I	S3U	
S4U			01-57-2-L	CPO SR	S4U		
S4U			01-60-0A-L	PASSAGE	S4U		
S4U			01-60-0B-L	PASSAGE	S4U		
S4U			01-60-0C-L	PASSAGE	S4U		
S4U			01-83-2-L	CPO SR	S4U		
S4U			03-56-0A-C	PILOT HOUSE	S4U		
S4U			03-66-01-C	ELEX, IC & GYRO ROOM	S4U		
			02-57-1-L	CO SR	(CUI = L1)		
NPU		NPU	02-57-0-L	CO CABIN	NPU		NPU
NPU		NPU	02-63-1-L	CO WR, WC, SH	NPU		NPU
S3U	S3U		(none)	(weather bulkhead)	S3I	S3U	
S3U	S3U		(none)	(weather bulkhead)	S3I	S3U	
S4U			01-57-0-Q	WARD ROOM PANTRY	S4U		
S4U			01-60-1-L	WARDROOM MESSROOM &	S4U		
S4I			03-56-0A-C	PILOT HOUSE	S4I		
S4U			(none)	(weather overhead)	S4I		
			02-57-2-L	XO WR, WC, SH	(CUI = LW)		

Table D.2 Barrier Data

Ship Visit Barrier Materials			Plan ID	Compartment Name Adjacent Compartment	Preliminary Baseline Barrier Materials		
<1>	<2>	<3>			<1>	<2>	<3>
S2U		S2U	02-57-0C-L	PASSAGE	S2U		S2U
NPU		NPU	02-57-4-L	XO SR	NPU		NPU
NPU		NPU	02-57-4-L	XO SR	NPU		NPU
S3I	S3U		(none)	(weather bulkhead)	S3I	S3U	
S4U			01-57-2-L	CPO SR	S4U		
S4U			01-57-4-L	CPO WR, WC, SH	S4U		
S2U			03-56-0A-C	PILOT HOUSE	S4I		
			02-57-4-L	XO SR	(CUI = L1)		
S2U		S2U	02-57-0C-L	PASSAGE	S2U		S2U
NPU		NPU	02-57-2-L	XO WR, WC, SH	NPU		NPU
NPU		NPU	02-57-2-L	XO WR, WC, SH	NPU		NPU
NPU		NPU	02-63-2-L	OFFICER SR	NPU		NPU
S3I	S3U		(none)	(weather bulkhead)	S3I	S3U	
S3I	S3U		(none)	(weather bulkhead)	S3I	S3U	
S4U			01-57-2-L	CPO SR	S4U		
S4U			01-57-4-L	CPO WR, WC, SH	S4U		
S4I			03-56-0A-C	PILOT HOUSE	S4I		
S4I			(none)	(weather overhead)	S4I		
			02-59-2-L	COMPANIONWAY	(CUI = LP)		
S2U		S2U	02-57-0-L	CO CABIN	S2U		S2U
S2U		S2U	02-57-0-L	CO CABIN	S2U		S2U
S2U		S2U	02-57-0C-L	PASSAGE	S2U		S2U
S2U		S2U	02-61-2-L	COMPANIONWAY	S2U		S2U
S4U			01-57-0-Q	WARD ROOM PANTRY	S4U		
S4U			01-57-2-L	CPO SR	S4U		
S4U			01-60-0C-L	PASSAGE	S4U		
S4U			03-56-0A-C	PILOT HOUSE	S4U		
			02-61-2-L	COMPANIONWAY	(CUI = LP)		
S2U		S2U	02-57-0-L	CO CABIN	S2U		S2U
S2U		S2U	02-57-0C-L	PASSAGE	S2U		S2U
S2U		S2U	02-59-2-L	COMPANIONWAY	S2U		S2U
S3U		S3U	02-66-0-C	RADIO ROOM	S3U		S3U
S3U		S3U	02-66-0-C	RADIO ROOM	S3U		S3U
S4U			01-60-0B-L	PASSAGE	S4U		
S4U			01-60-0C-L	PASSAGE	S4U		
S4U			03-56-0A-C	PILOT HOUSE	S4U		
S4U			03-66-0-L	DECK WR & WC	S4U		
S4U			03-66-01-C	ELEX, IC & GYRO ROOM	S4U		
			02-63-1-L	CO WR, WC, SH	(CUI = LW)		
S2U		NPU	02-57-0-L	CO CABIN	NPU		NPU
NPU		NPU	02-57-1-L	CO SR	NPU		NPU
S2U		S2U	02-66-1-L	OFFICER WR, WC, SH	NPU		NPU
S3I	S3U		(none)	(weather bulkhead)	S3I	S3U	
S4U			01-60-1-L	WARDROOM MESSROOM &	S4U		
S4I			03-56-0A-C	PILOT HOUSE	S4I		
S4I			03-56-0B-C	PILOT HOUSE (CHART A	S4I		

Table D.2 Barrier Data

Ship Visit Barrier Materials			Plan ID	Compartment Name Adjacent Compartment	Preliminary Baseline Barrier Materials		
<1>	<2>	<3>			<1>	<2>	<3>
S4I			(none)	(weather overhead)	S4I		
			02-63-2-L	OFFICER SR	(CUI = L2)		
S2U		S2U	02-57-0C-L	PASSAGE	S2U		S2U
NPU		NPU	02-57-4-L	XO SR	NPU		NPU
S2U		S2U	02-66-2-L	OFFICER WR, WC, SH	NPU		NPU
S2U		S2U	02-66-4-L	OFFICER WR, WC, SH	NPU		NPU
S3I	S3U		(none)	(weather bulkhead)	S3I	S3U	
S4U			01-83-2-L	CPO SR	S4U		
S4I			03-56-0A-C	PILOT HOUSE	S4I		
S4I			(none)	(weather overhead)	S4I		
			02-66-0-C	RADIO ROOM	(CUI = C)		
S3U		S3I	02-57-0-L	CO CABIN	S3I		S3U
S3U		S3U	02-57-0A-L	PASSAGE	S3U		S3U
S3U		S3U	02-57-0C-L	PASSAGE	S3U		S3U
S3U		S3U	02-61-2-L	COMPANIONWAY	S3U		S3U
S3U		S3U	02-61-2-L	COMPANIONWAY	S3U		S3U
S3U		S3U	02-66-1-L	OFFICER WR, WC, SH	S3I		S3U
S3U		S3I	02-69-1-L	OFFICER SR	S3I		S3U
S4U			01-60-0B-L	PASSAGE	S4U		
S4U			01-68-0-Q	SHIP OFFICE	S4U		
S4U			01-68-1-L	MEDICAL TREATMENT RO	S4U		
S4U			03-56-0B-C	PILOT HOUSE (CHART A	S4U		
S4U			03-66-0-L	DECK WR & WC	S4U		
S4U			03-66-01-C	ELEX, IC & GYRO ROOM	S4U		
			02-66-1-L	OFFICER WR, WC, SH	(CUI = LW)		
S2U		S2U	02-63-1-L	CO WR, WC, SH	NPU		NPU
S3U		S3U	02-66-0-C	RADIO ROOM	S3U		S3I
NPU		NPU	02-69-1-L	OFFICER SR	NPU		NPU
S3I	S3U		(none)	(weather bulkhead)	S3I	S3U	
S4U			01-60-0B-L	PASSAGE	S4U		
S4U			01-68-1-L	MEDICAL TREATMENT RO	S4U		
S4U			03-56-0B-C	PILOT HOUSE (CHART A	S4U		
S4I			(none)	(weather overhead)	S4I		
			02-66-2-L	OFFICER WR, WC, SH	(CUI = LW)		
S2U		S2U	02-57-0C-L	PASSAGE	S2U		S2U
S2U		S2U	02-63-2-L	OFFICER SR	NPU		NPU
S2U		S2U	02-66-4-L	OFFICER WR, WC, SH	NPU		NPU
S2U		S2U	02-69-2-Q	CG LKR W/SINK	S2U		S2U
NPU		NPU	02-69-4-L	OFFICER SR	NPU		NPU
S4U			01-66-2-L	PASSAGE	S4U		
S4I			03-56-0A-C	PILOT HOUSE	S4I		
S4I			(none)	(weather overhead)	S4I		
			02-66-4-L	OFFICER WR, WC, SH	(CUI = LW)		
S2U		S2U	02-63-2-L	OFFICER SR	NPU		NPU
S2U		S2U	02-66-2-L	OFFICER WR, WC, SH	NPU		NPU
NPU		NPU	02-69-4-L	OFFICER SR	NPU		NPU

Table D.2 Barrier Data

Ship Visit Barrier Materials			Plan ID	Compartment Name Adjacent Compartment	Preliminary Baseline Barrier Materials		
<1>	<2>	<3>			<1>	<2>	<3>
S3I	S3U		(none)	(weather bulkhead)	S3I	S3U	
S4U			01-66-2-L	PASSAGE	S4U		
S4I			(none)	(weather overhead)	S4I		
			02-69-1-L	OFFICER SR	(CUI = L2)		
S2I		S2U	02-57-0A-L	PASSAGE	S2U		S2U
S2U		S2U	02-57-0B-L	PASSAGE	S2U		S2U
S3I		S3U	02-66-0-C	RADIO ROOM	S3U		S3I
NPU		NPU	02-66-1-L	OFFICER WR, WC, SH	NPU		NPU
S3U		S3I	02-75-1-Q	PFD & SURVIVAL SUIT	S3I		S3U
S3I	S3U		(none)	(weather bulkhead)	S3I	S3U	
S4U			01-68-1-L	MEDICAL TREATMENT RO	S4U		
S4I			03-56-0B-C	PILOT HOUSE (CHART A	S4I		
S4I			(none)	(weather overhead)	S4I		
			02-69-2-Q	CG LKR W/SINK	(CUI = AG)		
S2U		S2U	02-57-0A-L	PASSAGE	S2U		S2U
S2U		S2U	02-57-0C-L	PASSAGE	S2U		S2U
S2U		S2U	02-66-2-L	OFFICER WR, WC, SH	S2U		S2U
S2U		S2U	02-69-4-L	OFFICER SR	S2U		S2U
S4U			01-66-2-L	PASSAGE	S4U		
S4U			03-56-0A-C	PILOT HOUSE	S4U		
			02-69-4-L	OFFICER SR	(CUI = L2)		
S3U		S3U	02-57-0A-L	PASSAGE	S3U		S3U
NPU		NPU	02-66-2-L	OFFICER WR, WC, SH	NPU		NPU
NPU		NPU	02-66-4-L	OFFICER WR, WC, SH	NPU		NPU
S2U		S2U	02-69-2-Q	CG LKR W/SINK	S2U		S2U
S2U		S2I	02-73-0-Q	FAN ROOM	S2U		S2U
S3U		S3I	02-75-2-Q	PFD & SURVIVAL SUIT	S3I		S3U
S3I	S3U		(none)	(weather bulkhead)	S3I	S3U	
S4U			01-66-2-L	PASSAGE	S4U		
S4U			01-70-2-Q	C.G. LKR	S4U		
S4U			01-71-2-L	CPO WR, WC, SH	S4U		
S4I			01-74-2-L	CPO SR	S4I		
S4I			03-56-0A-C	PILOT HOUSE	S4I		
S4I			(none)	(weather overhead)	S4I		
			02-73-0-Q	FAN ROOM	(CUI = QF)		
S3U		S3U	1-76-0-Q	MMR (UPTAKE)	S3U		S3U
S3U		S3U	1-76-0-Q	MMR (UPTAKE)	S3U		S3U
S3I		S3U	1-76-0-Q	MMR (UPTAKE)	S3I		S3U
S3I		S3U	1-80-1-Q	VENT PLENUM	S3I		S3U
S3I		S3U	02-57-0A-L	PASSAGE	S3U		S3U
S3I		S3U	02-57-0B-L	PASSAGE	S3U		S3U
S2I		S2U	02-69-4-L	OFFICER SR	S2U		S2U
S2I		S2U	02-75-2-Q	PFD & SURVIVAL SUIT	S2U		S2U
S3I	S3U		(none)	(weather bulkhead)	S3I	S3U	
S3I	S3U		(none)	(weather bulkhead)	S3I	S3U	
S4U			01-60-0A-L	PASSAGE	S4U		

Table D.2 Barrier Data

Ship Visit Barrier Materials			Plan ID	Compartment Name Adjacent Compartment	Preliminary Baseline Barrier Materials		
<1>	<2>	<3>			<1>	<2>	<3>
S4U			01-68-0-Q	SHIP OFFICE	S4U		
S4U			01-68-1-L	MEDICAL TREATMENT RO	S4U		
S4U			01-71-2-L	CPO WR, WC, SH	S4U		
S4U			01-74-1-L	MEDICAL TREATMENT WR	S4U		
S4I			01-74-2-L	CPO SR	S4I		
S4U			01-78-1-F	EMERGENCY GEN SERVIC	S4U		
S4I			03-76-0-Q	STACK	S4I		
S4I			(none)	(weather overhead)	S4I		
			02-75-1-Q	PFD & SURVIVAL SUIT LOCKER	(CUI = AG)		
S3U		S3U	02-57-0B-L	PASSAGE	S3U		S3U
S3I		S3U	02-69-1-L	OFFICER SR	S3U		S3I
S3I	S3U		(none)	(weather bulkhead)	S3U	S3U	
S3I	S3U		(none)	(weather bulkhead)	S3U	S3U	
S4U			01-68-1-L	MEDICAL TREATMENT RO	S4U		
S4I			(none)	(weather overhead)	S4I		
			02-75-2-Q	PFD & SURVIVAL SUIT LOCKER	(CUI = AG)		
S3I		S3U	02-69-4-L	OFFICER SR	S3U		S3I
S2U		S2I	02-73-0-Q	FAN ROOM	S2U		S2U
S3I	S3U		(none)	(weather bulkhead)	S3U	S3U	
S3I	S3U		(none)	(weather bulkhead)	S3U	S3U	
S4I			01-74-2-L	CPO SR	S4I		
S4I			(none)	(weather overhead)	S4I		
			02-85-0-Q	INCINERATOR ROOM	(CUI = QG)		
S3U		S3I	1-76-0-Q	MMR (UPTAKE)	S3I		S3U
S3I	S3U		(none)	(weather bulkhead)	S3I	S3U	
S3I	S3U		(none)	(weather bulkhead)	S3I	S3U	
S3I	S3U		(none)	(weather bulkhead)	S3I	S3U	
S3I	S3U		(none)	(weather bulkhead)	S3I	S3U	
S3I	S3U		(none)	(weather bulkhead)	S3I	S3U	
S4I			01-78-3-E	EMERGENCY GENERATOR	S4I		
S4I			01-79-0A-L	PASSAGE	S4I		
S4I			01-79-0B-L	PASSAGE	S4I		
S4I			01-88-0-L	CREW SR	S4I		
S4I			01-88-1-L	CREW WR, WC & SH	S4I		
S4U			(none)	(weather overhead)	S4U		
			03-56-0A-C	PILOT HOUSE	(CUI = C)		
S2U		S2U	03-56-0B-C	PILOT HOUSE (CHART A	S2U		S2U
000		000	03-56-0B-C	PILOT HOUSE (CHART A	000		000
S3U		S3U	03-66-0-L	DECK WR & WC	S3U		S3U
S2U		S2U	03-66-01-C	ELEX, IC & GYRO ROOM	S2U		S2U
S2U		S2U	03-66-01-C	ELEX, IC & GYRO ROOM	S2U		S2U
S2I	S3U		(none)	(weather bulkhead)	S3I	S3U	
S2I	S3U		(none)	(weather bulkhead)	S3I	S3U	
S2I	S3U		(none)	(weather bulkhead)	S3I	S3U	
S2I	S3U		(none)	(weather bulkhead)	S3I	S3U	
S2I	S3U		(none)	(weather bulkhead)	S3I	S3U	

Table D.2 Barrier Data

Ship Visit Barrier Materials			Plan ID	Compartment Name Adjacent Compartment	Preliminary Baseline Barrier Materials		
<1>	<2>	<3>			<1>	<2>	<3>
S2I	S3U		(none)	(weather bulkhead)	S3I	S3U	
S2I	S3U		(none)	(weather bulkhead)	S3I	S3U	
S2I	S3U		(none)	(weather bulkhead)	S3I	S3U	
S4U			02-57-0-L	CO CABIN	S4U		
S4I			02-57-0A-L	PASSAGE	S4I		
S4U			02-57-0C-L	PASSAGE	S4U		
S4I			02-57-1-L	CO SR	S4I		
S2U			02-57-2-L	XO WR, WC, SH	S4I		
S4I			02-57-4-L	XO SR	S4I		
S4U			02-59-2-L	COMPANIONWAY	S4U		
S4U			02-61-2-L	COMPANIONWAY	S4U		
S4I			02-63-1-L	CO WR, WC, SH	S4I		
S4I			02-63-2-L	OFFICER SR	S4I		
S4I			02-66-2-L	OFFICER WR, WC, SH	S4I		
S4U			02-69-2-Q	CG LKR W/SINK	S4U		
S4I			02-69-4-L	OFFICER SR	S4I		
S4I			(none)	(weather overhead)	S4I		
			03-56-0B-C	PILOT HOUSE (CHART AREA)	(CUI = C)		
S2U		S2U	03-56-0A-C	PILOT HOUSE	S2U		S2U
000		000	03-56-0A-C	PILOT HOUSE	000		000
S3U		S3U	03-66-0-L	DECK WR & WC	S3U		S3U
S2U		S2U	03-66-01-C	ELEX, IC & GYRO ROOM	S2U		S2U
S3I	S3U		(none)	(weather bulkhead)	S3I	S3U	
S3I	S3U		(none)	(weather bulkhead)	S3I	S3U	
S4U			02-57-0-L	CO CABIN	S4U		
S4I			02-57-0A-L	PASSAGE	S4I		
S4I			02-63-1-L	CO WR, WC, SH	S4I		
S4U			02-66-0-C	RADIO ROOM	S4U		
S4U			02-66-1-L	OFFICER WR, WC, SH	S4U		
S4I			02-69-1-L	OFFICER SR	S4I		
S4I			(none)	(weather overhead)	S4I		
			03-66-0-L	DECK WR & WC	(CUI = LW)		
S3U		S3U	03-56-0A-C	PILOT HOUSE	S3U		S3U
S3U		S3U	03-56-0B-C	PILOT HOUSE (CHART A	S3U		S3U
S3U		S3U	03-66-01-C	ELEX, IC & GYRO ROOM	S3U		S3U
S3U		S3U	03-66-01-C	ELEX, IC & GYRO ROOM	S3U		S3U
S4U			02-61-2-L	COMPANIONWAY	S4U		
S4U			02-66-0-C	RADIO ROOM	S4U		
S4I			(none)	(weather overhead)	S4I		
			03-66-01-C	ELEX, IC & GYRO ROOM	(CUI = C)		
S2U		S2U	03-56-0A-C	PILOT HOUSE	S2U		S2U
S2U		S2U	03-56-0A-C	PILOT HOUSE	S2U		S2U
S2U		S2U	03-56-0B-C	PILOT HOUSE (CHART A	S2U		S2U
S3U		S3U	03-66-0-L	DECK WR & WC	S3U		S3U
S3U		S3U	03-66-0-L	DECK WR & WC	S3U		S3U
S3I	S3U		(none)	(weather bulkhead)	S3I	S3U	

Table D.2 Barrier Data

Ship Visit Barrier Materials			Plan ID	Compartment Name Adjacent Compartment	Preliminary Baseline Barrier Materials		
<1>	<2>	<3>			<1>	<2>	<3>
S4I			02-57-0A-L	PASSAGE	S4I		
S4U			02-57-0C-L	PASSAGE	S4U		
S4U			02-61-2-L	COMPANIONWAY	S4U		
S4U			02-66-0-C	RADIO ROOM	S4U		
S4I			(none)	(weather overhead)	S4I		
			03-76-0-Q	STACK	(CUI = TU)		
S3I	S3U		(none)	(weather bulkhead)	S3U	S3U	
S3I	S3U		(none)	(weather bulkhead)	S3U	S3U	
S3I	S3U		(none)	(weather bulkhead)	S3U	S3U	
S3I	S3U		(none)	(weather bulkhead)	S3U	S3U	
S4U			1-76-0-Q	MMR (UPTAKE)	S4U		
S4U			1-80-1-Q	VENT PLENUM	S4U		
S4I			02-73-0-Q	FAN ROOM	S4I		
S4U			(none)	(weather overhead)	S4U		

Table D.3 Probability of Flame Termination

Plan ID	Compartment Name	I Values			A Values			M Values		
		EB	TBAR	DBAR	EB	TBAR	DBAR	EB	TBAR	DBAR
CUI=AA	(Cargo Hold) Frequency of EB=0.0001									
2-30-0-AA	CARGO HOLD	91	100	68	40	40	20	25	68	28
CUI=AG	(Gear Locker) Frequency of EB=0.0010									
3-6-0-Q	CHAIN LOCKER SUMP	99	33	16	0	0	0	9	30	15
2-6-1-Q	CHAIN LOCKER	99	33	16	0	0	0	9	30	15
2-6-2-Q	CHAIN LOCKER	99	33	16	0	0	0	9	30	15
1-77-1-A	CREW LOCKER	27	33	16	0	0	0	25	30	15
1-82-2-Q	C.G. LKR W/ SINK	27	33	16	0	0	0	25	30	15
01-70-2-Q	C.G. LKR	27	33	16	0	0	0	25	30	15
01-85-2-Q	FOUL WEATHER GEAR LKR	27	33	16	0	0	0	25	30	15
02-69-2-Q	CG LKR W/SINK	27	33	16	0	0	0	25	30	15
02-75-1-Q	PFD & SURVIVAL SUIT LOCKER	15	33	16	0	0	0	25	30	15
02-75-2-Q	PFD & SURVIVAL SUIT LOCKER	15	33	16	0	0	0	25	30	15
CUI=AR	(Refrigerated Storage) Frequency of EB=0.0009									
1-60-2-A	CHILL STRM	66	79	52	0	0	0	34	40	27
1-60-4-A	FREEZE STRM	66	79	52	0	0	0	34	40	27
CUI=AS	(Storeroom) Frequency of EB=0.0009									
3-57-0-A	SUPPLY DEPT. STOREROOM NO. 2	39	42	23	0	0	0	28	56	28
2-21-1-A	SUPPLY DEPT STOREROOM NO. 1	39	42	23	0	0	0	28	56	28
2-50-1-A	ENGINEER STOREROOM	39	42	23	0	0	0	28	56	28
2-57-2-A	SHIP STORE	39	42	23	0	0	0	28	56	28
1-0-0-A	BOATSWAIN STOREROOM NO. 1	39	42	23	0	0	0	28	56	28
1-6-1-A	BOATSWAIN STOREROOM NO. 2	39	42	23	0	0	0	28	56	28
1-18-4-A	ATON STRM	39	42	23	0	0	0	28	56	28
1-60-6A-A	DRY PROVISION STOREROOM	39	42	23	0	0	0	28	56	28
1-60-6B-A	DRY PROVISION STOREROOM	39	42	23	0	0	0	28	56	28
1-102-2-A	DECK GEAR STOREROOM	39	42	23	0	0	0	28	56	28
CUI=C	(Ship Control/Communications) Frequency of EB=0.0012									
2-89-1-C	ENGINEERING CONTROL CENTER	46	42	23	0	0	0	29	31	17
01-27-0-C	BUOY DECK CONTROL BOOTH	63	42	23	0	0	0	25	31	17
02-66-0-C	RADIO ROOM	35	42	23	0	0	0	29	31	17
03-56-0A-C	PILOT HOUSE	49	42	23	0	0	0	29	31	17
03-56-0B-C	PILOT HOUSE (CHART AREA)	49	42	23	0	0	0	29	31	17
03-66-01-C	ELEX, IC & GYRO ROOM	39	42	23	0	0	0	29	31	17
CUI=EM	(Main Propulsion - Mechanical) Frequency of EB=0.0272									
4-12-0-E	BOWTHRUSTER MCHRY ROOM	69	66	36	52	42	21	13	16	7
4-66-0-E	MAIN MACHINERY ROOM	54	66	36	68	42	21	12	16	7
4-92-0-E	STERN THRUSTER MACHRY ROOM	69	66	36	52	42	21	13	16	7
1-102-0-E	STEERING GEAR ROOM	63	66	36	52	42	21	13	16	7
CUI=K	(Hazardous Material Storage) Frequency of EB=0.0013									
1-6-2-A	FLAM. LIQ. STOREROOM	15	15	7	64	45	22	12	12	6
CUI=L1	(Senior Officer's Cabin) Frequency of EB=0.0008									
02-57-0-L	CO CABIN	49	58	24	0	0	0	25	32	15
02-57-1-L	CO SR	49	58	24	0	0	0	25	32	15
02-57-4-L	XO SR	49	58	24	0	0	0	25	32	15

Table D.3 Probability of Flame Termination

CUI=L2	(Officer/CPO Quarters) Frequency of EB=0.0008									
01-57-2-L	CPO SR	50	55	30	0	0	0	25	40	17
01-74-2-L	CPO SR	50	55	30	0	0	0	25	40	17
01-80-0-L	CREW SR	50	55	30	0	0	0	25	40	17
01-83-2-L	CPO SR	50	55	30	0	0	0	25	40	17
01-86-1-L	CREW SR	50	55	30	0	0	0	25	40	17
01-88-0-L	CREW SR	50	55	30	0	0	0	25	40	17
01-88-2-L	CREW SR	50	55	30	0	0	0	25	40	17
02-63-2-L	OFFICER SR	50	55	30	0	0	0	25	40	17
02-69-1-L	OFFICER SR	50	55	30	0	0	0	25	40	17
02-69-4-L	OFFICER SR	50	55	30	0	0	0	25	40	17
CUI=L5	(Crews Berthing) Frequency of EB=0.0008									
1-85-1-L	CREW SR	59	59	35	0	0	0	26	52	23
1-85-3-L	CREW SR	59	59	35	0	0	0	26	52	23
1-85-4-L	CREW SR	59	59	35	0	0	0	26	52	23
1-92-1-L	CREW SR	59	59	35	0	0	0	26	52	23
1-92-2-L	CREW SR	59	59	35	0	0	0	26	52	23
1-96-0-L	CREW SR	59	59	35	0	0	0	26	52	23
CUI=LL	(Wardroom/Mess/Lounge Areas) Frequency of EB=0.0008									
1-66-0-L	CREW MESS	31	34	18	0	0	0	39	48	23
1-77-2-L	CPO MESS & LOUNGE	31	34	18	0	0	0	39	48	23
1-77-3-L	CREW LOUNGE	31	34	18	0	0	0	39	48	23
01-60-1-L	WARDROOM MESSROOM & LOUNGE	31	34	18	0	0	0	39	48	23
CUI=LM	(Medical/Dental Spaces) Frequency of EB=0.0004									
01-68-1-L	MEDICAL TREATMENT ROOM	35	38	21	0	0	0	29	36	17
CUI=LP	(Passageway/Staircase/Vestibule) Frequency of EB=0.0001									
3-21-0-L	PASSAGE	79	79	71	0	0	0	62	68	55
2-21-0-L	PASSAGE	79	79	71	0	0	0	62	68	55
2-36-1-L	PASSAGE	79	79	71	0	0	0	62	68	55
2-39-1-L	PASSAGE	79	79	71	0	0	0	62	68	55
2-48-1-L	PASSAGE	79	79	71	0	0	0	62	68	55
2-53-1-L	VESTIBULE	86	79	71	0	0	0	62	68	55
2-57-0-L	PASSAGE	79	79	71	0	0	0	62	68	55
1-12-1A-L	PASSAGE	79	79	71	0	0	0	62	68	55
1-12-1B-L	PASSAGE	79	79	71	0	0	0	62	68	55
1-15-1-L	COMPANIONWAY	86	79	71	0	0	0	62	68	55
1-21-1-L	VESTIBULE	86	79	71	0	0	0	62	68	55
1-21-3-L	COMPANIONWAY	86	79	71	0	0	0	62	68	55
1-57-2-L	PASSAGE	79	79	71	0	0	0	62	68	55
1-59-2-L	COMPANIONWAY	86	79	71	0	0	0	62	68	55
1-66-2-L	COMPANIONWAY	86	79	71	0	0	0	62	68	55
1-82-0-L	PASSAGE	79	79	71	0	0	0	62	68	55
1-84-2-L	COMPANIONWAY	86	79	71	0	0	0	62	68	55
1-92-0-L	PASSAGE	79	79	71	0	0	0	62	68	55
01-60-0A-L	PASSAGE	79	79	71	0	0	0	62	68	55
01-60-0B-L	PASSAGE	79	79	71	0	0	0	62	68	55
01-60-0C-L	PASSAGE	79	79	71	0	0	0	62	68	55
01-66-2-L	PASSAGE	79	79	71	0	0	0	62	68	55
01-79-0A-L	PASSAGE	79	79	71	0	0	0	62	68	55
01-79-0B-L	PASSAGE	79	79	71	0	0	0	62	68	55
01-92-0-L	COMPANIONWAY	86	79	71	0	0	0	62	68	55

Table D.3 Probability of Flame Termination

02-57-0A-L	PASSAGE	79	79	71	0	0	0	62	68	55
02-57-0B-L	PASSAGE	79	79	71	0	0	0	62	68	55
02-57-0C-L	PASSAGE	79	79	71	0	0	0	62	68	55
02-59-2-L	COMPANIONWAY	86	79	71	0	0	0	62	68	55
02-61-2-L	COMPANIONWAY	86	79	71	0	0	0	62	68	55
CUI=LW	(Sanitary Spaces) Frequency of EB=0.0002									
1-57-0-L	DECK WR & WC	92	92	73	0	0	0	31	34	27
1-57-4-Q	CHANGE ROOM	92	92	73	0	0	0	59	34	27
1-60-1-L	GALLEY WR & WC	92	92	73	0	0	0	31	34	27
1-82-1-L	CREW WR, WC & SH	92	92	73	0	0	0	31	34	27
1-82-3-L	CREW WR, WC & SH	92	92	73	0	0	0	31	34	27
1-82-4-L	CREW WR, WC & SH	92	92	73	0	0	0	31	34	27
1-96-1-L	CREW WR, WC & SH	92	92	73	0	0	0	31	34	27
1-97-4-L	CREW WR, WC & SH	92	92	73	0	0	0	31	34	27
1-98-1-L	CREW WR, WC & SH	92	92	73	0	0	0	31	34	27
01-57-4-L	CPO WR, WC, SH	92	92	73	0	0	0	31	34	27
01-71-2-L	CPO WR, WC, SH	92	92	73	0	0	0	31	34	27
01-74-1-L	MEDICAL TREATMENT WR, WC & SH	92	92	73	0	0	0	31	34	27
01-84-2-L	CREW WR, WC & SH	92	92	73	0	0	0	31	34	27
01-88-1-L	CREW WR, WC & SH	92	92	73	0	0	0	31	34	27
02-57-2-L	XO WR, WC, SH	92	92	73	0	0	0	31	34	27
02-63-1-L	CO WR, WC, SH	92	92	73	0	0	0	31	34	27
02-66-1-L	OFFICER WR, WC, SH	92	92	73	0	0	0	31	34	27
02-66-2-L	OFFICER WR, WC, SH	92	92	73	0	0	0	31	34	27
02-66-4-L	OFFICER WR, WC, SH	92	92	73	0	0	0	31	34	27
03-66-0-L	DECK WR & WC	92	92	73	0	0	0	31	34	27
CUI=QA	(Aux Machinery Spaces) Frequency of EB=0.0029									
4-82-0-E	AUXILIARY MACHINERY ROOM	50	50	35	68	42	21	13	14	9
2-21-2-Q	POTABLE WATER PUMP ROOM	50	50	35	0	0	0	13	14	9
2-48-2-E	SOR PUMP ROOM	50	50	35	52	42	21	13	14	9
2-49-0-E	SOR MACHINERY ROOM	50	50	35	52	42	21	13	14	9
2-57-4-E	WATER SUPPLY EQPT ROOM	50	50	35	0	0	0	13	14	9
1-18-1-Q	D.C. REPAIR LKR NO. 1	50	50	35	0	0	0	13	14	9
1-18-2-Q	AFFF STA.	50	50	35	0	0	0	10	14	9
1-74-2-Q	DC REPAIR LKR NO. 2	50	50	35	0	0	0	33	14	9
1-85-2-Q	AFFF STA.	50	50	35	0	0	0	22	14	9
CUI=QE	(Emergency Aux Generator Spaces) Frequency of EB=0.0204									
01-78-1-F	EMERGENCY GEN SERVICE TK	0	43	25	45	45	22	13	14	9
01-78-3-E	EMERGENCY GENERATOR ROOM	43	43	25	64	45	22	13	14	9
CUI=QF	(Fan Room) Frequency of EB=0.0004									
1-97-2-Q	FAN ROOM	66	52	39	0	0	0	55	100	41
02-73-0-Q	FAN ROOM	66	52	39	0	0	0	55	100	41
CUI=QG	(Galley/Pantry/Scullery) Frequency of EB=0.0026									
1-57-1-Q	GALLEY	79	79	47	0	0	0	26	36	20
1-66-1-Q	GALLEY ANNEX	79	79	47	0	0	0	26	36	20
1-66-3-Q	SCULLERY	79	79	47	0	0	0	46	36	20
01-57-0-Q	WARD ROOM PANTRY	79	79	47	0	0	0	26	36	20
02-85-0-Q	INCINERATOR ROOM	40	79	47	52	42	21	29	36	20
CUI=QL	(Laundry) Frequency of EB=0.0031									
1-105-2-Q	LAUNDRY	35	43	26	0	0	0	33	49	19

Table D.3 Probability of Flame Termination

CUI=QO	(Office Spaces) Frequency of EB=0.0004									
1-71-2-Q	ENG LOG OFFICE & DC CENTRAL	27	32	16	0	0	0	29	36	17
01-68-0-Q	SHIP OFFICE	27	32	16	0	0	0	29	36	17
CUI=QS	(Shops) Frequency of EB=0.0018									
2-57-1-Q	MACHINE SHOP	39	42	23	0	0	0	33	39	19
2-59-1-Q	ELEC/ELEX WORKSHOP & STORERM	39	42	23	0	0	0	33	39	19
1-12-3-Q	BOATSWAIN SHOP	39	42	23	0	0	0	33	39	19
1-21-2-Q	ATON SHOP	39	42	23	0	0	0	33	39	19
CUI=TH	(Trunks/Hoists/Dumbwaiters) Frequency of EB=0.0001									
3-23-0-Q	CRANE PEDESTAL	98	100	58	0	0	0	9	40	20
1-19-2-T	ESC TRUNK	98	100	58	0	0	0	34	40	20
1-57-3-Q	DUMBWAITER TRUNK	98	100	58	0	0	0	34	40	20
1-80-1-E	VENT PLENUM	98	100	58	0	0	0	34	40	20
1-80-1-Q	VENT PLENUM	98	100	58	0	0	0	34	40	20
CUI=TU	(Stacks/Engine Uptakes) Frequency of EB=0.0013									
1-76-0-Q	MMR (UPTAKE)	19	15	8	0	0	0	7	9	4
03-76-0-Q	STACK	19	15	8	0	0	0	7	9	4
CUI=V	(Voids/Cofferdams) Frequency of EB=0.0001									
4-17-2-V	VOID	100	100	100	0	0	0	47	47	47
4-37-2-V	VOID	100	100	100	0	0	0	47	47	47
4-39-0-V	VOID	100	100	100	0	0	0	47	47	47
4-39-0A-V	VOID	100	100	100	0	0	0	47	47	47
4-39-0C-V	VOID	100	100	100	0	0	0	47	47	47
3-51-0-V	VOID	100	100	100	0	0	0	47	47	47
2-39-0-V	COFFERDAM	100	100	100	0	0	0	47	47	47
2-39-2-V	VOID	100	100	100	0	0	0	47	47	47
2-48-0-V	COFFERDAM	100	100	100	0	0	0	47	47	47
CUI=W	(Water Tank (empty)) Frequency of EB=0.0004									
4-21-0A-W	SW BALLAST TANK	100	100	100	0	0	0	47	47	47
4-21-0B-W	SW BALLAST TANK	100	100	100	0	0	0	47	47	47
4-21-0C-W	SW BALLAST TANK	100	100	100	0	0	0	47	47	47
4-30-3-W	SW BALLAST TANK	100	100	100	0	0	0	47	47	47
4-30-4-W	SW BALLAST TANK	100	100	100	0	0	0	47	47	47
4-48-0A-W	SW BALLAST TANK	100	100	100	0	0	0	47	47	47
4-48-0B-W	SW BALLAST TANK	100	100	100	0	0	0	47	47	47
4-48-0C-W	SW BALLAST TANK	100	100	100	0	0	0	47	47	47
4-57-0A-W	SW BALLAST TANK	100	100	100	0	0	0	47	47	47
4-57-0B-W	SW BALLAST TANK	100	100	100	0	0	0	47	47	47
4-57-0C-W	SW BALLAST TANK	100	100	100	0	0	0	47	47	47
4-80-0-W	SEA BAY	100	100	100	0	0	0	47	47	47
4-0-0-W	SW BALLAST TANK	100	100	100	0	0	0	47	47	47
4-6-0A-W	SW BALLAST TANK	100	100	100	0	0	0	47	47	47
4-6-0B-W	SW BALLAST TANK	100	100	100	0	0	0	47	47	47
4-6-0C-W	SW BALLAST TANK	100	100	100	0	0	0	47	47	47
2-25-1-WW	POTABLE WATER (CARGO)	100	100	100	0	0	0	47	47	47
2-25-2-W	POTABLE WATER (SHIP)	100	100	100	0	0	0	47	47	47

Table D.4 Fuel Loads

Plan ID	Compartment Name	Cellulosics (psf)	Plastics (psf)	Flam. Liq. (gal)	Total Fuel (kBTUs/sf)	Growth Model	Stack Ht. %	% Deck Occupied
CUI=AA	(Cargo Hold)							
2-30-0-AA	CARGO HOLD	4.0	0.3	0	36.8	1	10	50
CUI=AG	(Gear Locker)							
3-6-0-Q	CHAIN LOCKER SUMP	0.0	0.0	0	0.0	16	NA	0
2-6-1-Q	CHAIN LOCKER	0.0	2.3	0	36.8	16	NA	10
2-6-2-Q	CHAIN LOCKER	0.0	2.3	0	36.8	16	NA	10
1-77-1-A	CREW LOCKER	8.0	4.0	0	128.0	5	NA	75
1-82-2-Q	C.G. LKR W/ SINK	3.8	2.5	0	70.4	5	NA	75
01-70-2-Q	C.G. LKR	3.8	2.5	0	70.4	5	NA	75
01-85-2-Q	FOUL WEATHER GEAR LKR	8.0	4.0	0	128.0	12	NA	75
02-69-2-Q	CG LKR W/SINK	3.8	2.5	0	70.4	5	NA	75
02-75-1-Q	PFD & SURVIVAL SUIT LOCKER	14.0	0.2	0	115.2	12	NA	75
02-75-2-Q	PFD & SURVIVAL SUIT LOCKER	14.0	0.2	0	115.2	12	NA	75
CUI=AR	(Refrigerated Storage)							
1-60-2-A	CHILL STRM	0.5	0.5	0	12.0	16	NA	75
1-60-4-A	FREEZE STRM	0.5	0.5	0	12.0	16	NA	75
CUI=AS	(Storeroom)							
3-57-0-A	SUPPLY DEPT. STOREROOM NO. 2	10.0	2.0	1	112.4	5	NA	75
2-21-1-A	SUPPLY DEPT STOREROOM NO. 1	10.0	2.0	1	113.1	5	NA	75
2-50-1-A	ENGINEER STOREROOM	10.0	2.0	1	112.7	5	NA	75
2-57-2-A	SHIP STORE	10.0	2.0	1	113.6	6	NA	75
1-0-0-A	BOATSWAIN STOREROOM NO. 1	10.0	2.0	1	112.6	2	90	75
1-6-1-A	BOATSWAIN STOREROOM NO. 2	10.0	2.0	1	113.1	2	90	75
1-18-4-A	ATON STRM	10.0	2.0	1	113.1	5	NA	75
1-60-6A-A	DRY PROVISION STOREROOM	10.0	2.0	1	113.5	2	90	75
1-60-6B-A	DRY PROVISION STOREROOM	10.0	2.0	1	113.7	2	90	75
1-102-2-A	DECK GEAR STOREROOM	10.0	2.0	1	113.4	5	NA	75
CUI=C	(Ship Control/Communications)							
2-89-1-C	ENGINEERING CONTROL CENTER	7.0	1.2	0	75.2	7	NA	75
01-27-0-C	BUOY DECK CONTROL BOOTH	7.0	1.2	0	75.2	7	NA	75
02-66-0-C	RADIO ROOM	7.0	1.2	0	75.2	7	NA	75
03-56-0A-C	PILOT HOUSE	7.0	1.2	0	75.2	7	NA	75
03-56-0B-C	PILOT HOUSE (CHART AREA)	7.0	1.2	0	75.2	7	NA	75
03-66-01-C	ELEX, IC & GYRO ROOM	7.0	1.2	0	75.2	7	NA	75
CUI=EM	(Main Propulsion - Mechanical)							
4-12-0-E	BOWTHRUSTER MCHRY ROOM	0.7	0.8	0	18.4	13	NA	50
4-66-0-E	MAIN MACHINERY ROOM	0.7	0.8	60	24.9	13	NA	75
4-92-0-E	STERN THRUSTER MACHRY ROOM	0.7	0.8	0	18.4	13	NA	50
1-102-0-E	STEERING GEAR ROOM	0.7	0.8	25	28.4	13	NA	50
CUI=K	(Hazardous Material Storage)							
1-6-2-A	FLAM. LIQ. STOREROOM	1.0	0.2	35	43.5	1	90	75
CUI=L1	(Senior Officer's Cabin)							
02-57-0-L	CO CABIN	4.0	1.5	0	56.0	9	NA	50
02-57-1-L	CO SR	4.0	1.5	0	56.0	10	NA	50
02-57-4-L	XO SR	4.0	1.5	0	56.0	10	NA	50
CUI=L2	(Officer/CPO Quarters)							
01-57-2-L	CPO SR	5.0	1.0	0	56.0	10	NA	50
01-74-2-L	CPO SR	5.0	1.0	0	56.0	10	NA	50
01-80-0-L	CREW SR	5.0	1.0	0	56.0	10	NA	50
01-83-2-L	CPO SR	5.0	1.0	0	56.0	10	NA	50

Table D.4 Fuel Loads

Plan ID	Compartment Name	Cellulosics (psf)	Plastics (psf)	Flam. Liq. (gal)	Total Fuel (kBTUs/sf)	Growth Model	Stack Ht. %	% Deck Occupied
01-86-1-L	CREW SR	5.0	1.0	0	56.0	10	NA	50
01-88-0-L	CREW SR	5.0	1.0	0	56.0	10	NA	50
01-88-2-L	CREW SR	5.0	1.0	0	56.0	10	NA	50
02-63-2-L	OFFICER SR	5.0	1.0	0	56.0	10	NA	50
02-69-1-L	OFFICER SR	5.0	1.0	0	56.0	10	NA	50
02-69-4-L	OFFICER SR	5.0	1.0	0	56.0	10	NA	50
CUI=L5	(Crews Berthing)							
1-85-1-L	CREW SR	6.0	1.0	0	64.0	10	NA	50
1-85-3-L	CREW SR	6.0	1.0	0	64.0	10	NA	50
1-85-4-L	CREW SR	6.0	1.0	0	64.0	10	NA	50
1-92-1-L	CREW SR	6.0	1.0	0	64.0	10	NA	50
1-92-2-L	CREW SR	6.0	1.0	0	64.0	10	NA	50
1-96-0-L	CREW SR	6.0	1.0	0	64.0	10	NA	50
CUI=LL	(Wardroom/Mess/Lounge Areas)							
1-66-0-L	CREW MESS	2.5	0.5	0	28.0	9	NA	50
1-77-2-L	CPO MESS & LOUNGE	2.5	0.5	0	28.0	9	NA	50
1-77-3-L	CREW LOUNGE	2.5	0.5	0	28.0	9	NA	50
01-60-1-L	WARDROOM MESSROOM & LOUNGE	2.5	0.5	0	28.0	9	NA	50
CUI=LM	(Medical/Dental Spaces)							
01-68-1-L	MEDICAL TREATMENT ROOM	13.0	4.0	3	169.7	7	NA	75
CUI=LP	(Passageway/Staircase/Vestibule)							
3-21-0-L	PASSAGE	3.0	1.0	0	40.0	15	NA	25
2-21-0-L	PASSAGE	3.0	1.0	0	40.0	15	NA	25
2-36-1-L	PASSAGE	3.0	1.0	0	40.0	15	NA	25
2-39-1-L	PASSAGE	3.0	1.0	0	40.0	15	NA	25
2-48-1-L	PASSAGE	3.0	1.0	0	40.0	15	NA	25
2-53-1-L	VESTIBULE	3.0	1.0	0	40.0	15	NA	25
2-57-0-L	PASSAGE	3.0	1.0	0	40.0	15	NA	25
1-12-1A-L	PASSAGE	3.0	1.0	0	40.0	15	NA	25
1-12-1B-L	PASSAGE	3.0	1.0	0	40.0	15	NA	25
1-15-1-L	COMPANIONWAY	3.0	1.0	0	40.0	14	NA	25
1-21-1-L	VESTIBULE	3.0	1.0	0	40.0	15	NA	25
1-21-3-L	COMPANIONWAY	3.0	1.0	0	40.0	14	NA	25
1-57-2-L	PASSAGE	3.0	1.0	0	40.0	15	NA	25
1-59-2-L	COMPANIONWAY	3.0	1.0	0	40.0	14	NA	25
1-66-2-L	COMPANIONWAY	3.0	1.0	0	40.0	14	NA	25
1-82-0-L	PASSAGE	3.0	1.0	0	40.0	15	NA	25
1-84-2-L	COMPANIONWAY	3.0	1.0	0	40.0	14	NA	25
1-92-0-L	PASSAGE	3.0	1.0	0	40.0	15	NA	25
01-60-0A-L	PASSAGE	3.0	1.0	0	40.0	15	NA	25
01-60-0B-L	PASSAGE	3.0	1.0	0	40.0	15	NA	25
01-60-0C-L	PASSAGE	3.0	1.0	0	40.0	15	NA	25
01-66-2-L	PASSAGE	3.0	1.0	0	40.0	15	NA	25
01-79-0A-L	PASSAGE	3.0	1.0	0	40.0	15	NA	25
01-79-0B-L	PASSAGE	3.0	1.0	0	40.0	15	NA	25
01-92-0-L	COMPANIONWAY	3.0	1.0	0	40.0	14	NA	25
02-57-0A-L	PASSAGE	3.0	1.0	0	40.0	15	NA	25
02-57-0B-L	PASSAGE	3.0	1.0	0	40.0	15	NA	25
02-57-0C-L	PASSAGE	3.0	1.0	0	40.0	15	NA	25
02-59-2-L	COMPANIONWAY	3.0	1.0	0	40.0	14	NA	25

Table D.4 Fuel Loads

Plan ID	Compartment Name	Cellulosics (psf)	Plastics (psf)	Flam. Liq. (gal)	Total Fuel (kBTUs/sf)	Growth Model	Stack Ht. %	% Deck Occupied
02-61-2-L	COMPANIONWAY	3.0	1.0	0	40.0	14	NA	25
CUI=LW	(Sanitary Spaces)							
1-57-0-L	DECK WR & WC	1.4	0.2	0	14.4	16	NA	25
1-57-4-Q	CHANGE ROOM	2.1	0.5	0	24.8	12	NA	25
1-60-1-L	GALLEY WR & WC	1.4	0.2	0	14.4	16	NA	25
1-82-1-L	CREW WR, WC & SH	1.4	0.2	0	14.4	16	NA	25
1-82-3-L	CREW WR, WC & SH	1.4	0.2	0	14.4	16	NA	25
1-82-4-L	CREW WR, WC & SH	1.4	0.2	0	14.4	16	NA	25
1-96-1-L	CREW WR, WC & SH	1.4	0.2	0	14.4	16	NA	25
1-97-4-L	CREW WR, WC & SH	1.4	0.2	0	14.4	16	NA	25
1-98-1-L	CREW WR, WC & SH	1.4	0.2	0	14.4	16	NA	25
01-57-4-L	CPO WR, WC, SH	1.5	0.3	0	16.8	16	NA	25
01-71-2-L	CPO WR, WC, SH	1.5	0.3	0	16.8	16	NA	25
01-74-1-L	MEDICAL TREATMENT WR, WC & SH	1.8	0.3	0	19.2	16	NA	25
01-84-2-L	CREW WR, WC & SH	1.4	0.2	0	14.4	16	NA	25
01-88-1-L	CREW WR, WC & SH	1.4	0.2	0	14.4	16	NA	25
02-57-2-L	XO WR, WC, SH	1.8	0.3	0	19.2	16	NA	25
02-63-1-L	CO WR, WC, SH	1.8	0.3	0	19.2	16	NA	25
02-66-1-L	OFFICER WR, WC, SH	1.5	0.3	0	16.8	16	NA	25
02-66-2-L	OFFICER WR, WC, SH	1.5	0.3	0	16.8	16	NA	25
02-66-4-L	OFFICER WR, WC, SH	1.5	0.3	0	16.8	16	NA	25
03-66-0-L	DECK WR & WC	1.5	0.3	0	16.8	16	NA	25
CUI=QA	(Aux Machinery Spaces)							
4-82-0-E	AUXILIARY MACHINERY ROOM	2.0	2.0	5	48.8	13	NA	50
2-21-2-Q	POTABLE WATER PUMP ROOM	2.0	2.0	5	51.3	13	NA	50
2-48-2-E	SOR PUMP ROOM	2.0	2.0	5	50.4	13	NA	50
2-49-0-E	SOR MACHINERY ROOM	2.0	2.0	5	51.1	13	NA	50
2-57-4-E	WATER SUPPLY EQPT ROOM	2.0	2.0	5	51.4	13	NA	50
1-18-1-Q	D.C. REPAIR LKR NO. 1	4.4	2.9	0	81.6	13	NA	50
1-18-2-Q	AFFF STA.	2.0	2.0	5	65.4	13	NA	50
1-74-2-Q	DC REPAIR LKR NO. 2	4.4	2.9	0	81.6	5	NA	75
1-85-2-Q	AFFF STA.	2.0	2.0	5	64.0	13	NA	50
CUI=QE	(Emergency Aux Generator Spaces)							
01-78-1-F	EMERGENCY GEN SERVICE TK	0.0	0.0	0	0.0	16	NA	0
01-78-3-E	EMERGENCY GENERATOR ROOM	1.0	2.0	15	50.0	13	NA	50
CUI=QF	(Fan Room)							
1-97-2-Q	FAN ROOM	1.0	1.0	0	24.0	13	NA	25
02-73-0-Q	FAN ROOM	1.0	1.0	0	24.0	13	NA	25
CUI=QG	(Galley/Pantry/Scullery)							
1-57-1-Q	GALLEY	2.1	0.5	1	25.2	16	NA	50
1-66-1-Q	GALLEY ANNEX	2.1	0.5	1	26.3	16	NA	50
1-66-3-Q	SCULLERY	2.1	0.6	1	27.8	16	NA	50
01-57-0-Q	WARD ROOM PANTRY	2.1	0.5	1	26.0	13	NA	50
02-85-0-Q	INCINERATOR ROOM	2.0	1.0	1	33.3	5	NA	50
CUI=QL	(Laundry)							
1-105-2-Q	LAUNDRY	3.7	1.8	0	58.4	12	NA	75
CUI=QO	(Office Spaces)							
1-71-2-Q	ENG LOG OFFICE & DC CENTRAL	8.0	2.0	0	96.0	7	NA	75
01-68-0-Q	SHIP OFFICE	8.0	2.0	0	96.0	7	NA	75
CUI=QS	(Shops)							

Table D.4 Fuel Loads

Plan ID	Compartment Name	Cellulosics (psf)	Plastics (psf)	Flam. Liq. (gal)	Total Fuel (kBTUs/sf)	Growth Model	Stack Ht. %	% Deck Occupied
2-57-1-Q	MACHINE SHOP	0.3	0.2	0	5.6	7	NA	75
2-59-1-Q	ELEC/ELEX WORKSHOP & STORERM	0.5	0.5	0	12.0	7	NA	75
1-12-3-Q	BOATSWAIN SHOP	0.5	0.5	0	12.0	5	NA	75
1-21-2-Q	ATON SHOP	0.4	0.2	0	6.4	13	NA	75
CUI=TH	(Trunks/Hoists/Dumbwaiters)							
3-23-0-Q	CRANE PEDESTAL	1.0	0.5	0	16.0	16	NA	50
1-19-2-T	ESC TRUNK	1.0	0.5	0	16.0	16	NA	10
1-57-3-Q	DUMBWAITER TRUNK	1.0	0.5	0	16.0	16	NA	10
1-80-1-E	VENT PLENUM	1.0	0.5	0	16.0	16	NA	10
1-80-1-Q	VENT PLENUM	1.0	0.5	0	16.0	16	NA	10
CUI=TU	(Stacks/Engine Uptakes)							
1-76-0-Q	MMR (UPTAKE)	0.2	0.8	0	14.4	13	NA	25
03-76-0-Q	STACK	0.2	0.8	0	14.4	13	NA	25
CUI=V	(Voids/Cofferdams)							
4-17-2-V	VOID	0.0	0.0	0	0.0	16	NA	0
4-37-2-V	VOID	0.0	0.0	0	0.0	16	NA	0
4-39-0-V	VOID	0.0	0.0	0	0.0	16	NA	0
4-39-0A-V	VOID	0.0	0.0	0	0.0	16	NA	0
4-39-0C-V	VOID	0.0	0.0	0	0.0	16	NA	0
3-51-0-V	VOID	0.0	0.0	0	0.0	16	NA	0
2-39-0-V	COFFERDAM	0.0	0.0	0	0.0	16	NA	0
2-39-2-V	VOID	0.0	0.0	0	0.0	16	NA	0
2-48-0-V	COFFERDAM	0.0	0.0	0	0.0	16	NA	0
CUI=W	(Water Tank (empty))							
4-21-0A-W	SW BALLAST TANK	0.0	0.0	0	0.0	16	NA	0
4-21-0B-W	SW BALLAST TANK	0.0	0.0	0	0.0	16	NA	0
4-21-0C-W	SW BALLAST TANK	0.0	0.0	0	0.0	16	NA	0
4-30-3-W	SW BALLAST TANK	0.0	0.0	0	0.0	16	NA	0
4-30-4-W	SW BALLAST TANK	0.0	0.0	0	0.0	16	NA	0
4-48-0A-W	SW BALLAST TANK	0.0	0.0	0	0.0	16	NA	0
4-48-0B-W	SW BALLAST TANK	0.0	0.0	0	0.0	16	NA	0
4-48-0C-W	SW BALLAST TANK	0.0	0.0	0	0.0	16	NA	0
4-57-0A-W	SW BALLAST TANK	0.0	0.0	0	0.0	16	NA	0
4-57-0B-W	SW BALLAST TANK	0.0	0.0	0	0.0	16	NA	0
4-57-0C-W	SW BALLAST TANK	0.0	0.0	0	0.0	16	NA	0
4-80-0-W	SEA BAY	0.0	0.0	0	0.0	16	NA	0
4-0-0-W	SW BALLAST TANK	0.0	0.0	0	0.0	16	NA	0
4-6-0A-W	SW BALLAST TANK	0.0	0.0	0	0.0	16	NA	0
4-6-0B-W	SW BALLAST TANK	0.0	0.0	0	0.0	16	NA	0
4-6-0C-W	SW BALLAST TANK	0.0	0.0	0	0.0	16	NA	0
2-25-1-WW	POTABLE WATER (CARGO)	0.0	0.0	0	0.0	16	NA	0
2-25-2-W	POTABLE WATER (SHIP)	0.0	0.0	0	0.0	16	NA	0

Table D.5.1

Readiness Condition X-RAY
 Configuration Passive, Automatic and Manual
 Case Worst
 Assumed Location In-Port
 Run Time 60 minutes

Target Compartment	Magnitude/Frequency -of Acceptable Loss-		Relative Frequency of Loss FFS	Relative Loss Factor (RLF)
1-66-0-L	2	21 years	0.0097	0.2038
4-66-0-E	2	25 years	0.0075	0.1879
4-82-0-E	2	24 years	0.0074	0.1778
1-76-0-Q	3	16 years	0.0100	0.1595
01-78-3-E	2	23 years	0.0064	0.1474
03-76-0-Q	3	16 years	0.0092	0.1466
2-89-1-C	2	25 years	0.0050	0.1257
2-57-4-E	2	24 years	0.0052	0.1257
1-85-2-Q	2	24 years	0.0052	0.1240
1-66-1-Q	2	22 years	0.0055	0.1205
4-92-0-E	2	25 years	0.0042	0.1044
1-18-2-Q	2	24 years	0.0041	0.0986
4-12-0-E	2	25 years	0.0039	0.0984
1-77-3-L	2	21 years	0.0045	0.0944
1-74-2-Q	2	24 years	0.0032	0.0777
2-21-2-Q	2	24 years	0.0032	0.0772
1-18-1-Q	2	24 years	0.0031	0.0743
1-77-2-L	2	21 years	0.0031	0.0657
1-21-2-Q	3	15 years	0.0041	0.0616
2-57-1-Q	3	15 years	0.0037	0.0554
1-66-3-Q	2	22 years	0.0022	0.0488
03-66-01-C	2	25 years	0.0017	0.0418
03-56-0A-C	2	25 years	0.0015	0.0364
2-48-2-E	2	24 years	0.0013	0.0318
03-56-0B-C	2	25 years	0.0012	0.0292
02-66-0-C	2	25 years	0.0007	0.0171
1-6-2-A	1	30 years	0.0004	0.0132
02-73-0-Q	3	18 years	0.0007	0.0122
1-60-4-A	2	22 years	0.0004	0.0092
1-60-2-A	2	22 years	0.0004	0.0092
01-57-0-Q	2	22 years	0.0004	0.0089
1-57-1-Q	2	22 years	0.0004	0.0078
1-102-0-E	2	25 years	0.0003	0.0067
02-85-0-Q	2	22 years	0.0003	0.0062
2-59-1-Q	3	15 years	0.0004	0.0060
1-57-4-Q	3	11 years	0.0000	0.0004
2-49-0-E	2	24 years	0.0000	0.0003
1-6-2-A	1	30 years	0.0004	0.0128
02-75-1-Q	3	17 years	0.0007	0.0121
01-57-0-Q	2	26 years	0.0004	0.0112
1-6-1-A	3	13 years	0.0004	0.0056
2-49-0-E	2	23 years	0.0001	0.0030

Table D.5.2

Readiness Condition X-RAY
 Configuration Passive and Automatic
 Case Worst
 Assumed Location In-Port
 Run Time 60 minutes

Target Compartment	Magnitude/Frequency -of Acceptable Loss-		Relative Frequency of Loss FFS	Relative Loss Factor (RLF)
1-66-0-L	2	21 years	0.0204	0.4288
1-66-1-Q	2	22 years	0.0133	0.2934
03-76-0-Q	3	16 years	0.0165	0.2644
4-82-0-E	2	24 years	0.0109	0.2619
01-78-3-E	2	23 years	0.0113	0.2594
4-66-0-E	2	25 years	0.0101	0.2531
2-89-1-C	2	25 years	0.0093	0.2316
1-76-0-Q	3	16 years	0.0142	0.2276
1-85-2-Q	2	24 years	0.0082	0.1958
2-57-4-E	2	24 years	0.0081	0.1939
1-77-3-L	2	21 years	0.0087	0.1826
4-92-0-E	2	25 years	0.0056	0.1408
1-77-2-L	2	21 years	0.0066	0.1390
1-18-1-Q	2	24 years	0.0057	0.1367
1-21-2-Q	3	15 years	0.0088	0.1321
1-18-2-Q	2	24 years	0.0053	0.1273
1-74-2-Q	2	24 years	0.0051	0.1235
4-12-0-E	2	25 years	0.0047	0.1184
2-21-2-Q	2	24 years	0.0043	0.1026
2-57-1-Q	3	15 years	0.0057	0.0848
03-66-01-C	2	25 years	0.0031	0.0786
1-66-3-Q	2	22 years	0.0035	0.0776
03-56-0A-C	2	25 years	0.0025	0.0625
2-48-2-E	2	24 years	0.0022	0.0522
03-56-0B-C	2	25 years	0.0019	0.0471
02-66-0-C	2	25 years	0.0018	0.0439
02-73-0-Q	3	18 years	0.0022	0.0404
1-60-4-A	2	22 years	0.0012	0.0259
1-60-2-A	2	22 years	0.0012	0.0259
1-57-1-Q	2	22 years	0.0009	0.0194
1-6-2-A	1	30 years	0.0006	0.0190
1-102-0-E	2	25 years	0.0005	0.0136
2-59-1-Q	3	15 years	0.0009	0.0128
01-57-0-Q	2	22 years	0.0005	0.0120
02-85-0-Q	2	22 years	0.0004	0.0085
1-57-4-Q	3	11 years	0.0003	0.0031
2-49-0-E	2	24 years	0.0001	0.0028
02-75-2-Q	3	17 years	0.0020	0.0336
1-6-2-A	1	30 years	0.0007	0.0211
02-75-1-Q	3	17 years	0.0009	0.0145
01-57-0-Q	2	26 years	0.0005	0.0142
1-6-1-A	3	13 years	0.0006	0.0084
2-49-0-E	2	23 years	0.0002	0.0037

Table D.5.3

Readiness Condition X-RAY
Configuration Passive and Manual
Case Worst
Assumed Location In-Port
Run Time 60 minutes

Target Compartment	Magnitude/Frequency -of Acceptable Loss-		Relative Frequency of Loss FFS	Relative Loss Factor (RLF)
1-66-0-L	2	21 years	0.0296	0.6213
4-82-0-E	2	24 years	0.0237	0.5683
01-78-3-E	2	23 years	0.0230	0.5289
4-66-0-E	2	25 years	0.0198	0.4955
1-76-0-Q	3	16 years	0.0248	0.3961
1-66-1-Q	2	22 years	0.0172	0.3791
03-76-0-Q	3	16 years	0.0225	0.3598
1-85-2-Q	2	24 years	0.0148	0.3545
2-89-1-C	2	25 years	0.0137	0.3420
4-92-0-E	2	25 years	0.0131	0.3272
2-57-4-E	2	24 years	0.0128	0.3078
1-77-3-L	2	21 years	0.0117	0.2452
1-74-2-Q	2	24 years	0.0095	0.2269
4-12-0-E	2	25 years	0.0081	0.2024
1-77-2-L	2	21 years	0.0092	0.1926
1-18-2-Q	2	24 years	0.0064	0.1534
1-66-3-Q	2	22 years	0.0064	0.1401
2-48-2-E	2	24 years	0.0053	0.1282
2-57-1-Q	3	15 years	0.0085	0.1275
1-18-1-Q	2	24 years	0.0052	0.1256
2-21-2-Q	2	24 years	0.0049	0.1184
1-21-2-Q	3	15 years	0.0069	0.1028
03-66-01-C	2	25 years	0.0017	0.0418
03-56-0A-C	2	25 years	0.0015	0.0364
03-56-0B-C	2	25 years	0.0012	0.0292
2-59-1-Q	3	15 years	0.0015	0.0226
02-66-0-C	2	25 years	0.0007	0.0171
1-6-2-A	1	30 years	0.0004	0.0132
02-73-0-Q	3	18 years	0.0007	0.0122
1-102-0-E	2	25 years	0.0005	0.0115
1-60-4-A	2	22 years	0.0004	0.0096
1-60-2-A	2	22 years	0.0004	0.0096
1-57-1-Q	2	22 years	0.0004	0.0096
01-57-0-Q	2	22 years	0.0004	0.0089
02-85-0-Q	2	22 years	0.0004	0.0080
2-49-0-E	2	24 years	0.0000	0.0005
1-57-4-Q	3	11 years	0.0000	0.0004

Table D.5.4

Run 7-57

Readiness Condition X-RAY
Configuration Passive
Case Worst
Assumed Location In-Port
Run Time 60 minutes

Target Compartment	Magnitude/Frequency -of Acceptable Loss-		Relative Frequency of Loss FFS	Relative Loss Factor (RLF)
1-66-0-L	2	21 years	0.0639	1.3428
01-78-3-E	2	23 years	0.0393	0.9046
1-66-1-Q	2	22 years	0.0410	0.9014
4-82-0-E	2	24 years	0.0335	0.8030
4-66-0-E	2	25 years	0.0257	0.6427
03-76-0-Q	3	16 years	0.0389	0.6229
2-89-1-C	2	25 years	0.0221	0.5518
1-85-2-Q	2	24 years	0.0229	0.5504
1-76-0-Q	3	16 years	0.0333	0.5327
1-77-3-L	2	21 years	0.0231	0.4853
4-92-0-E	2	25 years	0.0183	0.4572
2-57-4-E	2	24 years	0.0180	0.4328
1-77-2-L	2	21 years	0.0183	0.3846
1-74-2-Q	2	24 years	0.0143	0.3425
1-21-2-Q	3	15 years	0.0164	0.2464
4-12-0-E	2	25 years	0.0096	0.2404
1-18-1-Q	2	24 years	0.0096	0.2308
1-66-3-Q	2	22 years	0.0100	0.2201
2-48-2-E	2	24 years	0.0086	0.2052
1-18-2-Q	2	24 years	0.0082	0.1972
2-57-1-Q	3	15 years	0.0124	0.1864
2-21-2-Q	2	24 years	0.0066	0.1583
03-66-01-C	2	25 years	0.0031	0.0786
03-56-0A-C	2	25 years	0.0025	0.0625
03-56-0B-C	2	25 years	0.0019	0.0471
2-59-1-Q	3	15 years	0.0031	0.0464
02-66-0-C	2	25 years	0.0018	0.0451
02-73-0-Q	3	18 years	0.0022	0.0404
1-60-4-A	2	22 years	0.0013	0.0285
1-60-2-A	2	22 years	0.0013	0.0285
2-49-0-E	2	24 years	0.0012	0.0279
1-102-0-E	2	25 years	0.0009	0.0234
1-57-1-Q	2	22 years	0.0011	0.0234
1-6-2-A	1	30 years	0.0006	0.0190
01-57-0-Q	2	22 years	0.0005	0.0120
02-85-0-Q	2	22 years	0.0005	0.0110
1-57-4-Q	3	11 years	0.0003	0.0035

Table D.5.5

Run 7-58

Readiness Condition YOKE
Configuration Passive, Automatic, and Manual
Case Worst
Assumed Location At Sea
Run Time 60 minutes

Target Compartment	Magnitude/Frequency -of Acceptable Loss-		Relative Frequency of Loss FFS	Relative Loss Factor (RLF)
1-66-0-L	2	21 years	0.0097	0.2038
4-66-0-E	2	25 years	0.0075	0.1879
4-82-0-E	2	24 years	0.0074	0.1778
1-76-0-Q	3	16 years	0.0100	0.1595
01-78-3-E	2	23 years	0.0064	0.1474
03-76-0-Q	3	16 years	0.0092	0.1466
2-89-1-C	2	25 years	0.0050	0.1257
2-57-4-E	2	24 years	0.0052	0.1257
1-85-2-Q	2	24 years	0.0052	0.1240
1-66-1-Q	2	22 years	0.0055	0.1205
4-92-0-E	2	25 years	0.0042	0.1044
1-18-2-Q	2	24 years	0.0041	0.0986
4-12-0-E	2	25 years	0.0039	0.0984
1-77-3-L	2	21 years	0.0045	0.0944
1-74-2-Q	2	24 years	0.0032	0.0777
2-21-2-Q	2	24 years	0.0032	0.0772
1-18-1-Q	2	24 years	0.0031	0.0743
1-77-2-L	2	21 years	0.0031	0.0657
1-21-2-Q	3	15 years	0.0041	0.0616
2-57-1-Q	3	15 years	0.0037	0.0554
1-66-3-Q	2	22 years	0.0022	0.0488
03-66-01-C	2	25 years	0.0017	0.0418
03-56-0A-C	2	25 years	0.0015	0.0364
2-48-2-E	2	24 years	0.0013	0.0318
03-56-0B-C	2	25 years	0.0012	0.0292
02-66-0-C	2	25 years	0.0007	0.0171
1-6-2-A	1	30 years	0.0004	0.0132
02-73-0-Q	3	18 years	0.0007	0.0122
1-60-4-A	2	22 years	0.0004	0.0092
1-60-2-A	2	22 years	0.0004	0.0092
01-57-0-Q	2	22 years	0.0004	0.0089
1-57-1-Q	2	22 years	0.0004	0.0078
1-102-0-E	2	25 years	0.0003	0.0067
02-85-0-Q	2	22 years	0.0003	0.0062
2-59-1-Q	3	15 years	0.0004	0.0060
1-57-4-Q	3	11 years	0.0000	0.0004
2-49-0-E	2	24 years	0.0000	0.0003

Table D.5.6

Run 7-59

Readiness Condition YOKE
Configuration Passive and Automatic
Case Worst
Assumed Location At Sea
Run Time 60 minutes

Target Compartment	Magnitude/Frequency -of Acceptable Loss-	Relative Frequency of Loss FFS	Relative Loss Factor (RLF)
1-66-0-L	2 21 years	0.0204	0.4288
1-66-1-Q	2 22 years	0.0133	0.2934
03-76-0-Q	3 16 years	0.0165	0.2644
4-82-0-E	2 24 years	0.0109	0.2619
01-78-3-E	2 23 years	0.0113	0.2594
4-66-0-E	2 25 years	0.0101	0.2531
2-89-1-C	2 25 years	0.0093	0.2316
1-76-0-Q	3 16 years	0.0142	0.2276
1-85-2-Q	2 24 years	0.0082	0.1958
2-57-4-E	2 24 years	0.0081	0.1939
1-77-3-L	2 21 years	0.0087	0.1826
4-92-0-E	2 25 years	0.0056	0.1408
1-77-2-L	2 21 years	0.0066	0.1390
1-18-1-Q	2 24 years	0.0057	0.1367
1-21-2-Q	3 15 years	0.0088	0.1321
1-18-2-Q	2 24 years	0.0053	0.1273
1-74-2-Q	2 24 years	0.0051	0.1235
4-12-0-E	2 25 years	0.0047	0.1184
2-21-2-Q	2 24 years	0.0043	0.1026
2-57-1-Q	3 15 years	0.0057	0.0848
03-66-01-C	2 25 years	0.0031	0.0786
1-66-3-Q	2 22 years	0.0035	0.0776
03-56-0A-C	2 25 years	0.0025	0.0625
2-48-2-E	2 24 years	0.0022	0.0522
03-56-0B-C	2 25 years	0.0019	0.0471
02-66-0-C	2 25 years	0.0018	0.0439
02-73-0-Q	3 18 years	0.0022	0.0404
1-60-4-A	2 22 years	0.0012	0.0259
1-60-2-A	2 22 years	0.0012	0.0259
1-57-1-Q	2 22 years	0.0009	0.0194
1-6-2-A	1 30 years	0.0006	0.0190
1-102-0-E	2 25 years	0.0005	0.0136
2-59-1-Q	3 15 years	0.0009	0.0128
01-57-0-Q	2 22 years	0.0005	0.0120
02-85-0-Q	2 22 years	0.0004	0.0085
1-57-4-Q	3 11 years	0.0003	0.0031
2-49-0-E	2 24 years	0.0001	0.0028

Table D.5.7

Run 7-60

Readiness Condition YOKE
Configuration Passive and Manual
Case Worst
Assumed Location At Sea
Run Time 60 minutes

Target Compartment	Magnitude/Frequency -of Acceptable Loss-		Relative Frequency of Loss FFS	Relative Loss Factor (RLF)
1-66-0-L	2	21 years	0.0296	0.6213
4-82-0-E	2	24 years	0.0237	0.5683
01-78-3-E	2	23 years	0.0230	0.5289
4-66-0-E	2	25 years	0.0198	0.4955
1-76-0-Q	3	16 years	0.0248	0.3961
1-66-1-Q	2	22 years	0.0172	0.3791
03-76-0-Q	3	16 years	0.0225	0.3598
1-85-2-Q	2	24 years	0.0148	0.3545
2-89-1-C	2	25 years	0.0137	0.3420
4-92-0-E	2	25 years	0.0131	0.3272
2-57-4-E	2	24 years	0.0128	0.3078
1-77-3-L	2	21 years	0.0117	0.2452
1-74-2-Q	2	24 years	0.0095	0.2269
4-12-0-E	2	25 years	0.0081	0.2024
1-77-2-L	2	21 years	0.0092	0.1926
1-18-2-Q	2	24 years	0.0064	0.1534
1-66-3-Q	2	22 years	0.0064	0.1401
2-48-2-E	2	24 years	0.0053	0.1282
2-57-1-Q	3	15 years	0.0085	0.1275
1-18-1-Q	2	24 years	0.0052	0.1256
2-21-2-Q	2	24 years	0.0049	0.1184
1-21-2-Q	3	15 years	0.0069	0.1028
03-66-01-C	2	25 years	0.0017	0.0418
03-56-0A-C	2	25 years	0.0015	0.0364
03-56-0B-C	2	25 years	0.0012	0.0292
2-59-1-Q	3	15 years	0.0015	0.0226
02-66-0-C	2	25 years	0.0007	0.0171
1-6-2-A	1	30 years	0.0004	0.0132
02-73-0-Q	3	18 years	0.0007	0.0122
1-102-0-E	2	25 years	0.0005	0.0115
1-60-4-A	2	22 years	0.0004	0.0096
1-60-2-A	2	22 years	0.0004	0.0096
1-57-1-Q	2	22 years	0.0004	0.0096
01-57-0-Q	2	22 years	0.0004	0.0089
02-85-0-Q	2	22 years	0.0004	0.0080
2-49-0-E	2	24 years	0.0000	0.0005
1-57-4-Q	3	11 years	0.0000	0.0004

Table D.5.8

Run 7-61

Readiness Condition YOKE
 Configuration Passive
 Case Worst
 Assumed Location At Sea
 Run Time 60 minutes

Target Compartment	Magnitude/Frequency -of Acceptable Loss-		Relative Frequency of Loss FFS	Relative Loss Factor (RLF)
1-66-0-L	2	21 years	0.0639	1.3428
01-78-3-E	2	23 years	0.0393	0.9046
1-66-1-Q	2	22 years	0.0410	0.9014
4-82-0-E	2	24 years	0.0335	0.8030
4-66-0-E	2	25 years	0.0257	0.6427
03-76-0-Q	3	16 years	0.0389	0.6229
2-89-1-C	2	25 years	0.0221	0.5518
1-85-2-Q	2	24 years	0.0229	0.5504
1-76-0-Q	3	16 years	0.0333	0.5327
1-77-3-L	2	21 years	0.0231	0.4853
4-92-0-E	2	25 years	0.0183	0.4572
2-57-4-E	2	24 years	0.0180	0.4328
1-77-2-L	2	21 years	0.0183	0.3846
1-74-2-Q	2	24 years	0.0143	0.3425
1-21-2-Q	3	15 years	0.0164	0.2464
4-12-0-E	2	25 years	0.0096	0.2404
1-18-1-Q	2	24 years	0.0096	0.2308
1-66-3-Q	2	22 years	0.0100	0.2201
2-48-2-E	2	24 years	0.0086	0.2052
1-18-2-Q	2	24 years	0.0082	0.1972
2-57-1-Q	3	15 years	0.0124	0.1864
2-21-2-Q	2	24 years	0.0066	0.1583
03-66-01-C	2	25 years	0.0031	0.0786
03-56-0A-C	2	25 years	0.0025	0.0625
03-56-0B-C	2	25 years	0.0019	0.0471
2-59-1-Q	3	15 years	0.0031	0.0464
02-66-0-C	2	25 years	0.0018	0.0451
02-73-0-Q	3	18 years	0.0022	0.0404
1-60-4-A	2	22 years	0.0013	0.0285
1-60-2-A	2	22 years	0.0013	0.0285
2-49-0-E	2	24 years	0.0012	0.0279
1-102-0-E	2	25 years	0.0009	0.0234
1-57-1-Q	2	22 years	0.0011	0.0234
1-6-2-A	1	30 years	0.0006	0.0190
01-57-0-Q	2	22 years	0.0005	0.0120
02-85-0-Q	2	22 years	0.0005	0.0110
1-57-4-Q	3	11 years	0.0003	0.0035

Table D.5.9

Run 7-62

Readiness Condition YOKE
Configuration Passive, Automatic, and Manual
Case Worst
Assumed Location In Port
Run Time 60 minutes

Target Compartment	Magnitude/Frequency -of Acceptable Loss-		Relative Frequency of Loss FFS	Relative Loss Factor (RLF)
1-66-0-L	2	21 years	0.0097	0.2038
4-66-0-E	2	25 years	0.0075	0.1879
4-82-0-E	2	24 years	0.0074	0.1778
1-76-0-Q	3	16 years	0.0100	0.1595
01-78-3-E	2	23 years	0.0064	0.1474
03-76-0-Q	3	16 years	0.0092	0.1466
2-89-1-C	2	25 years	0.0050	0.1257
2-57-4-E	2	24 years	0.0052	0.1257
1-85-2-Q	2	24 years	0.0052	0.1240
1-66-1-Q	2	22 years	0.0055	0.1205
4-92-0-E	2	25 years	0.0042	0.1044
1-18-2-Q	2	24 years	0.0041	0.0986
4-12-0-E	2	25 years	0.0039	0.0984
1-77-3-L	2	21 years	0.0045	0.0944
1-74-2-Q	2	24 years	0.0032	0.0777
2-21-2-Q	2	24 years	0.0032	0.0772
1-18-1-Q	2	24 years	0.0031	0.0743
1-77-2-L	2	21 years	0.0031	0.0657
1-21-2-Q	3	15 years	0.0041	0.0616
2-57-1-Q	3	15 years	0.0037	0.0554
1-66-3-Q	2	22 years	0.0022	0.0488
03-66-01-C	2	25 years	0.0017	0.0418
03-56-0A-C	2	25 years	0.0015	0.0364
2-48-2-E	2	24 years	0.0013	0.0318
03-56-0B-C	2	25 years	0.0012	0.0292
02-66-0-C	2	25 years	0.0007	0.0171
1-6-2-A	1	30 years	0.0004	0.0132
02-73-0-Q	3	18 years	0.0007	0.0122
1-60-4-A	2	22 years	0.0004	0.0092
1-60-2-A	2	22 years	0.0004	0.0092
01-57-0-Q	2	22 years	0.0004	0.0089
1-57-1-Q	2	22 years	0.0004	0.0078
1-102-0-E	2	25 years	0.0003	0.0067
02-85-0-Q	2	22 years	0.0003	0.0062
2-59-1-Q	3	15 years	0.0004	0.0060
1-57-4-Q	3	11 years	0.0000	0.0004
2-49-0-E	2	24 years	0.0000	0.0003

Table D.5.10

Readiness Condition YOKE
 Configuration Passive and Automatic
 Case Worst
 Assumed Location In Port
 Run Time 60 minutes

Target Compartment	Magnitude/Frequency -of Acceptable Loss-		Relative Frequency of Loss FFS	Relative Loss Factor (RLF)
1-66-0-L	2	21 years	0.0204	0.4288
1-66-1-Q	2	22 years	0.0133	0.2934
03-76-0-Q	3	16 years	0.0165	0.2644
4-82-0-E	2	24 years	0.0109	0.2619
01-78-3-E	2	23 years	0.0113	0.2594
4-66-0-E	2	25 years	0.0101	0.2531
2-89-1-C	2	25 years	0.0093	0.2316
1-76-0-Q	3	16 years	0.0142	0.2276
1-85-2-Q	2	24 years	0.0082	0.1958
2-57-4-E	2	24 years	0.0081	0.1939
1-77-3-L	2	21 years	0.0087	0.1826
4-92-0-E	2	25 years	0.0056	0.1408
1-77-2-L	2	21 years	0.0066	0.1390
1-18-1-Q	2	24 years	0.0057	0.1367
1-21-2-Q	3	15 years	0.0088	0.1321
1-18-2-Q	2	24 years	0.0053	0.1273
1-74-2-Q	2	24 years	0.0051	0.1235
4-12-0-E	2	25 years	0.0047	0.1184
2-21-2-Q	2	24 years	0.0043	0.1026
2-57-1-Q	3	15 years	0.0057	0.0848
03-66-01-C	2	25 years	0.0031	0.0786
1-66-3-Q	2	22 years	0.0035	0.0776
03-56-0A-C	2	25 years	0.0025	0.0625
2-48-2-E	2	24 years	0.0022	0.0522
03-56-0B-C	2	25 years	0.0019	0.0471
02-66-0-C	2	25 years	0.0018	0.0439
02-73-0-Q	3	18 years	0.0022	0.0404
1-60-4-A	2	22 years	0.0012	0.0259
1-60-2-A	2	22 years	0.0012	0.0259
1-57-1-Q	2	22 years	0.0009	0.0194
1-6-2-A	1	30 years	0.0006	0.0190
1-102-0-E	2	25 years	0.0005	0.0136
2-59-1-Q	3	15 years	0.0009	0.0128
01-57-0-Q	2	22 years	0.0005	0.0120
02-85-0-Q	2	22 years	0.0004	0.0085
1-57-4-Q	3	11 years	0.0003	0.0031
2-49-0-E	2	24 years	0.0001	0.0028

Table D.5.11

Run 7-64

Readiness Condition YOKE
Configuration Passive and Manual
Case Worst
Assumed Location In Port
Run Time 60 minutes

Target Compartment	Magnitude/Frequency -of Acceptable Loss-		Relative Frequency of Loss FFS	Relative Loss Factor (RLF)
1-66-0-L	2	21 years	0.0296	0.6213
4-82-0-E	2	24 years	0.0237	0.5683
01-78-3-E	2	23 years	0.0230	0.5289
4-66-0-E	2	25 years	0.0198	0.4955
1-76-0-Q	3	16 years	0.0248	0.3961
1-66-1-Q	2	22 years	0.0172	0.3791
03-76-0-Q	3	16 years	0.0225	0.3598
1-85-2-Q	2	24 years	0.0148	0.3545
2-89-1-C	2	25 years	0.0137	0.3420
4-92-0-E	2	25 years	0.0131	0.3272
2-57-4-E	2	24 years	0.0128	0.3078
1-77-3-L	2	21 years	0.0117	0.2452
1-74-2-Q	2	24 years	0.0095	0.2269
4-12-0-E	2	25 years	0.0081	0.2024
1-77-2-L	2	21 years	0.0092	0.1926
1-18-2-Q	2	24 years	0.0064	0.1534
1-66-3-Q	2	22 years	0.0064	0.1401
2-48-2-E	2	24 years	0.0053	0.1282
2-57-1-Q	3	15 years	0.0085	0.1275
1-18-1-Q	2	24 years	0.0052	0.1256
2-21-2-Q	2	24 years	0.0049	0.1184
1-21-2-Q	3	15 years	0.0069	0.1028
03-66-01-C	2	25 years	0.0017	0.0418
03-56-0A-C	2	25 years	0.0015	0.0364
03-56-0B-C	2	25 years	0.0012	0.0292
2-59-1-Q	3	15 years	0.0015	0.0226
02-66-0-C	2	25 years	0.0007	0.0171
1-6-2-A	1	30 years	0.0004	0.0132
02-73-0-Q	3	18 years	0.0007	0.0122
1-102-0-E	2	25 years	0.0005	0.0115
1-60-4-A	2	22 years	0.0004	0.0096
1-60-2-A	2	22 years	0.0004	0.0096
1-57-1-Q	2	22 years	0.0004	0.0096
01-57-0-Q	2	22 years	0.0004	0.0089
02-85-0-Q	2	22 years	0.0004	0.0080
2-49-0-E	2	24 years	0.0000	0.0005
1-57-4-Q	3	11 years	0.0000	0.0004

Table D.5.12

Run 7-65

Readiness Condition YOKE
Configuration Passive
Case Worst
Assumed Location In Port
Run Time 60 minutes

Target Compartment	Magnitude/Frequency -of Acceptable Loss-		Relative Frequency of Loss FFS	Relative Loss Factor (RLF)
1-66-0-L	2	21 years	0.0639	1.3428
01-78-3-E	2	23 years	0.0393	0.9046
1-66-1-Q	2	22 years	0.0410	0.9014
4-82-0-E	2	24 years	0.0335	0.8030
4-66-0-E	2	25 years	0.0257	0.6427
03-76-0-Q	3	16 years	0.0389	0.6229
2-89-1-C	2	25 years	0.0221	0.5518
1-85-2-Q	2	24 years	0.0229	0.5504
1-76-0-Q	3	16 years	0.0333	0.5327
1-77-3-L	2	21 years	0.0231	0.4853
4-92-0-E	2	25 years	0.0183	0.4572
2-57-4-E	2	24 years	0.0180	0.4328
1-77-2-L	2	21 years	0.0183	0.3846
1-74-2-Q	2	24 years	0.0143	0.3425
1-21-2-Q	3	15 years	0.0164	0.2464
4-12-0-E	2	25 years	0.0096	0.2404
1-18-1-Q	2	24 years	0.0096	0.2308
1-66-3-Q	2	22 years	0.0100	0.2201
2-48-2-E	2	24 years	0.0086	0.2052
1-18-2-Q	2	24 years	0.0082	0.1972
2-57-1-Q	3	15 years	0.0124	0.1864
2-21-2-Q	2	24 years	0.0066	0.1583
03-66-01-C	2	25 years	0.0031	0.0786
03-56-0A-C	2	25 years	0.0025	0.0625
03-56-0B-C	2	25 years	0.0019	0.0471
2-59-1-Q	3	15 years	0.0031	0.0464
02-66-0-C	2	25 years	0.0018	0.0451
02-73-0-Q	3	18 years	0.0022	0.0404
1-60-4-A	2	22 years	0.0013	0.0285
1-60-2-A	2	22 years	0.0013	0.0285
2-49-0-E	2	24 years	0.0012	0.0279
1-102-0-E	2	25 years	0.0009	0.0234
1-57-1-Q	2	22 years	0.0011	0.0234
1-6-2-A	1	30 years	0.0006	0.0190
01-57-0-Q	2	22 years	0.0005	0.0120
02-85-0-Q	2	22 years	0.0005	0.0110
1-57-4-Q	3	11 years	0.0003	0.0035

[BLANK]

Appendix E

FIRE PROTECTION DOCTRINE

The U.S. Coast Guard Cutter JUNIPER Fire Protection Doctrine is organized into three parts: Part A contains the principles of fire science which are relevant to shipboard fire protection. Part B contains official policies and guidance promulgated by the Commandant, U.S. Coast Guard that pertain to firefighting on "large" cutters. For the purposes of this fire protection doctrine, "small" cutters are defined to be all cutters 65' and greater in length and less than 180' in length. The 225' JUNIPER considered in this report is thus a "large" cutter in the Coast Guard fleet. Part C contains firefighting procedures and tactics for combating all classes of fires in all compartments in the JUNIPER class cutter. Specific procedures are provided for 15 individual compartments as well as in-port fires. Part C also contains information pertinent to firefighting in the JUNIPER such as:

- Compartmentation - Inboard and outboard profile and deck plan views of the JUNIPER are shown. In addition, location of particularly hazardous fuel loads are noted.
- Mechanical and electrical isolation details are provided for various systems and equipment.
- Ventilation and smoke control details are provided.
- Information concerning the fire and smoke detection system is provided.
- Specific information concerning installed and portable firefighting equipment is provided.

The following is an index for this appendix:

	Page
Part A Principles of Fire Science.....	E-2
Part B Policies for Firefighting on Large Cutters.....	E-19
Part C Procedures for Firefighting on JUNIPER.....	E-28

Fire Protection Doctrine - Part A

Principles of Fire Science

Table of Contents

I. Purpose	4
II. Shipboard Fire Protection	4
A. Philosophy	4
B. Fundamental Concepts of Fire	4
1. Fire Tetrahedron	5
2. Classification of Fire.....	5
3. Extinguishing Agents.....	6
a) Liquid	6
b) Gas	6
c) Solid	6
III. Prevention	7
A. Frequent Inspections	7
B. Proper Stowage of Combustibles.....	7
C. Training and Education	7
D. Enforcement of Fire Prevention Policies and Practices.....	7
IV. Detection	8
A. Equipment.....	8
1. Smoke Detectors (products of combustion).....	8
2. Heat-actuated Fire Detectors (fixed temperature, rate of rise).....	8
3. Flame Detectors (optical)	9
B. Operation	9
V. Confinement	9
A. Passive Measures	9
1. Compartmentation.....	9
a) Barriers	9
b) Fuel Loading.....	10
2. Construction Materials	10
B. Active Measures.....	10
1. Setting Material Condition ZEBRA.....	11
2. Securing Ventilation.....	11
3. Securing Fuel	11
4. Securing Electrical Power	11
VI. Extinguishment	11
A. Firefighting Equipment.....	11
1. Firemain System.....	12
2. Firehose and Nozzle.....	12
3. Portable Pumps	12
a) P-250 Mod 1 Pump	12
b) CG P-1B Pump	13
c) CG P-5 Pump.....	13
4. Automated Fixed Flooding Systems.....	13

a) CO ₂ System.....	13
b) Halon 1301 System.....	13
c) Aqueous Film Forming Foam (AFFF).....	14
d) Aqueous Potassium Carbonate.....	14
5. Portable Fire Extinguishers.....	14
a) Carbon Dioxide (CO ₂).....	14
b) Purple-K-Powder (PKP).....	15
6. Sprinkler Systems.....	15
B. Personnel Protection.....	15
1. Emergency Escape Breathing Device (EEBD).....	15
2. Oxygen Breathing Apparatus (OBA).....	15
3. Clothing.....	16
4. Naval Firefighting Thermal Imager (NFTI).....	16
5. Firefinder.....	17
VII. Post-Extinguishment Activities.....	17
A. Desmoking.....	17
1. Red-Devil Blower.....	17
2. Ram-Fan.....	17
B. Compartment Testing.....	17
C. Dewatering.....	18
D. Restoration of Ship's Systems.....	18
E. Examination and Investigation.....	18

Fire Protection Doctrine - Part A

Principles of Fire Science

I. Purpose

The purpose of this fire protection doctrine is to provide useful information pertinent to fire science (Part A), guidance promulgated by Commandant for firefighting on Coast Guard Cutters (Part B), and tactical firefighting procedures for each class of fire likely to be encountered, inport and underway (Part C). Part A of this doctrine applies to all Coast Guard Cutter Classes. Part B applies specifically to either "small" or "large" Coast Guard Cutter Classes. Small Cutters are defined, for the purposes of firefighting doctrine applicability, to be all cutter classes ranging in size from 65' WYTL Harbor Tugboats to 175' WLM (R) Coastal Buoy Tenders inclusive. Large Cutters are defined, for the purposes of firefighting doctrine applicability, to be all cutter classes ranging in size from 180' WLB Ocean-going Buoy Tenders to 399' WAGB Polar Icebreakers inclusive. Part C is Coast Guard Cutter Class specific and should be individually tailored to suit each ship in the class to account for minor differences. A complete fire protection doctrine for a cutter is therefore composed of three parts.

II. Shipboard Fire Protection

A. Philosophy

The guiding design philosophy of shipboard fire protection embraces a series of steps beginning with prevention and continuing in sequence through detection, confinement, control, extinguishment and finally post-extinguishment. It would be ideal if fires could be prevented from occurring in the first place, therefore considerable effort is made to prevent fires. If an unwanted fire does occur, it is desirable to detect the fire as early as possible and before the fire has a chance to grow. Detection can be accomplished with installed smoke, heat and flame detectors or the crew can detect the presence of smoke or fire. Once a fire is detected, the approach is to contain or isolate the fire to the "room of origin". If this is successful, the damage will be minimized. In some cases the fire will spread to involve other compartments through poorly designed (or maintained) bulkheads or open access fittings. In either event, the next step is to extinguish the fire. Extinguishment can be accomplished manually or with an automated, fixed fire protection system. The post-extinguishment step includes restoration of ship's systems to enable continuation of the ship's mission.

B. Fundamental Concepts of Fire

In a ship, fuels are present in solid, liquid and gaseous forms. Solid fuels include paper products, clothing, furniture, plastics and other common "ash-producing" substances. They are capable of smoldering for hours before bursting into visible flames. Plastic fuels (polyethylene, nylon, vinyls, etc.) usually produce higher burning rates and a higher heat content per unit weight than cellulosic fuels. In addition, plastics usually burn with extremely dense smoke and produce toxic gases such as carbon monoxide, hydrogen chloride and phosgene gas. Flammable liquids such as lube oil, hydraulic oil, diesel fuel,

JP-5, paints and solvents are usually found in engineering spaces and are often contained under pressure. Pound for pound, flammable liquids produce 2.5 times more heat than wood, and they release this heat 3 to 10 times faster. When flammable liquids spill, or worse, spray under pressure on a hot surface, the resulting fire burns with tremendous intensity. Many of the major conflagrations on ships are a result of flammable liquid spray fires in the engine room. There are both natural and manufactured flammable gases. Those commonly found on board ship include acetylene, propane, and butane. Gases, like flammable liquids, usually produce visible flames and will not smolder.

1. Fire Tetrahedron

Combustion or rapid oxidation describes a process in which a fuel pyrolyzes or turns into a vapor and mixes with oxygen at a high rate of speed; heat and light, visibly seen as flames, are by-products of this process. The heat generated by combustion travels in all directions including back toward the fire which in turn pyrolyzes more fuel and thus a chain reaction is established. Fuel, heat and oxygen are thus required for the existence of fire as well as the chain reaction process described. The fire tetrahedron, shown in Figure A-1, is a graphic representation of the combustion process. If any of the four faces of the tetrahedron are removed, the fire will be extinguished.

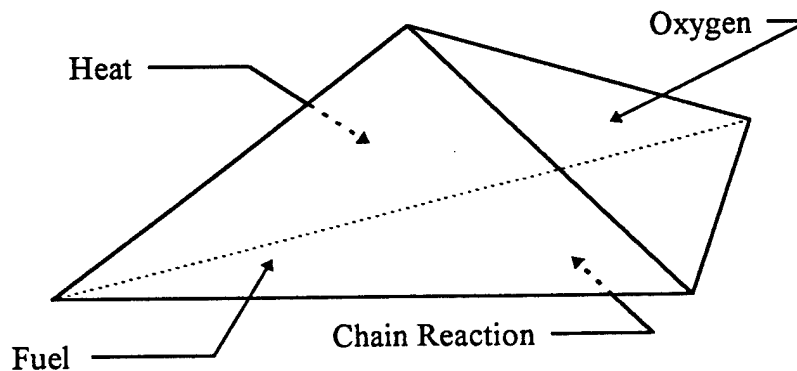

Figure A.1 The Fire Tetrahedron

2. Classification of Fire

Fires are grouped into four classes according to the type of fuel as shown in Table A-1. Sometimes due to the presence of multiple fuel types a combination of classes of fire will occur. Electrical fires, for example, almost always involve a solid or liquid fuel as well.

TABLE A.1 CLASSES OF FIRE

Class	Fuel
A	Solid Fuels
B	Flammable Liquids or Gases
C	Electrical
D	Combustible Metals

3. Extinguishing Agents

An extinguishing agent operates by removing one or more faces of the fire tetrahedron using one of the following four methods:

- Cooling. This is a direct attack on the heat face of the tetrahedron. The goal is to reduce the temperature of the fuel below its ignition temperature.
- Smothering. This is an attack on the edge of the tetrahedron where the fuel and oxygen meet. The action is to separate the fuel from the oxygen.
- Oxygen Dilution. This is an attack on the oxygen face where the goal is to reduce the oxygen content below that necessary to sustain combustion.
- Chain Reaction Breaking. The goal here is to interrupt the chain reaction long enough for the fuel to cool below its ignition point.

There are six fire extinguishing agents normally encountered in shipboard firefighting. These agents are in the form of liquids (3), gases (2) or solids (1). The choice of agent is based on the class of fire and the agents available to fight the fire. The following sections discuss the agents available, their advantages and disadvantages.

a) Liquid

By far the most common extinguishing agent is water. Salt or fresh water is very effective on class A fires while aqueous film-forming foam (AFFF) is effective against class B fires and deep seated class A fires. The advantage of using water is its inexhaustible supply; the disadvantage is that water conducts electricity and adversely affects the stability of the ship if too much accumulates. AFFF has persistence and will remain effective as a blanketing agent for several hours, but has to be washed from machinery after the fire is out. Aqueous potassium carbonate is primarily used to combat galley deep fat fryer fires and their exhaust systems.

b) Gas

Halon is a manufactured chlorofluorocarbon (CFC) and is extremely effective against all classes of fire. The advantages of Halon are that it is clean, non lethal (in concentrations sufficient to extinguish fire), non-conducting, and extremely fast in extinguishing fires. Like freon and other CFCs, it apparently damages the ozone in the atmosphere and is being phased out of production. CO_2 is an effective agent against class C fires and is non-conductive and non-corrosive. CO_2 is clean, effective, and environmentally acceptable, but it is lethal in quantities sufficient to extinguish fire.

c) Solid

Potassium bicarbonate powder (PKP) is the only dry chemical authorized for use in portable extinguishers on Coast Guard Cutters and Boats. PKP fire extinguishers are designed to be used on Class B fires. They may also be used on Class A fires, recognizing that they may have limited effectiveness. This agent is non-lethal and non-conducting but on the other hand it is corrosive to electronic equipment and difficult to clean up.

III. Prevention

There are four basic principles of fire prevention which should be observed routinely to reduce shipboard fire hazards.

A. Frequent Inspections

It is the responsibility of every crew member to prevent fires. Accordingly, the entire crew should be constantly alert to eliminate fire hazards. Fire hazards should be brought to the attention of the Commanding Officer/Officer-in-Charge who can take appropriate action.

B. Proper Stowage of Combustibles

Paint, flammable liquids, ordnance and munitions should only be stowed on board in spaces specifically designed for the purpose or on weather decks. These spaces will be protected with explosion proof lights, noncombustible shelving, fire detectors, and an automated total flooding fire protection system. Paint lockers, magazines and other spaces specifically designed for extremely flammable or explosive products are not generally found on small cutters.

C. Training and Education

Frequent fire drills and team training should be conducted so that in an emergency the crew will respond correctly and automatically. Education in the principles of fire science will permit the proper selection of a firefighting agent and equipment depending on the class of fire encountered. Training will permit the proper use of the firefighting equipment installed or available on board.

D. Enforcement of Fire Prevention Policies and Practices

The following policies and practices will minimize fire hazards and reduce the chances of uncontrolled growth if a fire should occur.

- Maintain flange shields on flammable liquid piping.
- Maintain proper covers on flammable liquid strainers.
- Keep sounding tube caps in place and isolation valves closed.
- Take immediate action to stop and repair all oil leaks.
- Keep ventilation ducts clean and free from oily residue.
- Keep bilges free of trash and oil.
- Do not allow unauthorized flammable materials on board.
- Do not stow combustible materials in voids or uptakes.
- Do not stow combustibles in direct contact with bulkheads and decks - allow for at least one foot stand-off distance.

- Perform preventive maintenance on firefighting equipment in accordance with authorized procedures. Ensure all interlocks work properly.
- Operate firefighting equipment in accordance with procedures established in this doctrine and other authorized documents.
- Maintain damage control closures and fittings in accordance with the authorized material condition of readiness.
- Comply with authorized tag-out procedures for electrical and mechanical equipment.

IV. Detection

There are two types of fire detectors: the installed smoke, heat and flame detectors found in berthing compartments, magazines, engine rooms, and other spaces, and the crew, who should be constantly vigilant to the presence of smoke or flames. A crew member has two basic duties to perform in the event that fire or smoke is detected: sounding the alarm, and making an effort to extinguish or at least contain the fire. The person discovering the fire should sound the alarm first then attempt to apply first aid. The crew member should attempt to extinguish the fire with the nearest available extinguisher that dispenses the appropriate firefighting agent if this first aid can be accomplished safely. If first aid is not immediately effective, the crew member should evacuate the space and contain the fire by closing the door to the compartment.

A. Equipment

Fire detectors sense, and initiate a signal in response to, heat, smoke, flame or some other indication of fire. The types of detectors that are in common use are discussed in the next section.

1. Smoke Detectors (products of combustion)

The smoke detector continuously samples the air for the products of combustion, specifically smoke particles. There are various types of smoke detector, the most common include the ionization and photoelectric types. Ionization detectors operate on the principle that smoke interferes with the flow of ionized particles created in the detector. The photoelectric type measures the amount of obscurity in a light beam created by the detector.

2. Heat-actuated Fire Detectors (fixed temperature, rate of rise)

The primary classes of heat-actuated devices are fixed-temperature detectors and rate-of-rise detectors. A fixed-temperature detector initiates an alarm when the temperature of the device reaches a pre-set value. Note the device itself has to reach this temperature - not just the air around it. This thermal lag is proportional to the rate of rise of the air temperature. Rate of rise detectors sense the rate at which the temperature is rising and sounds an alarm when this rate exceeds the allowable value. Rate of rise detectors will reset themselves, whereas fixed temperature detectors will not.

3. Flame Detectors (optical)

Flame detectors are designed to recognize certain characteristics of flames such as light intensity, flicker (pulsation) frequency and radiant energy levels. Flame detectors are not commonly found on board ship due to false alarms. For example arcs from welding, or light reflecting off the water's surface sometimes cause flickering which are misinterpreted by the detector. Electric light bulbs also tend to flicker if the ship is vibrating.

B. Operation

Detectors are designed to operate continuously with minimal maintenance and are inherently reliable. They are usually battery powered or wired for 110 volt electrical power. In general, on Coast Guard Cutters, detectors sound the alarm only, they do not automatically discharge a firefighting agent.

V. Confinement

The initial actions by the person who discovers a fire can make the difference between a controllable fire and one which threatens the life of the ship. Any crew member discovering a fire or an indication of fire must immediately sound the alarm. The report of a fire must reach the Officer of the Deck by whatever method available, such as messenger, telephone, announcing system, intercom, installed fire alarm system, or human voice. If the fire is small and appears capable of being controlled, then an initial attack can be attempted by personnel with little or no protection. The use of more than one portable extinguisher simultaneously is more effective than using them one at a time. If the fire is large, or if the compartment of origin is unknown, or if the fire is fed by a pressurized fuel source, then the initial actions should be to contain and isolate the fire. This can be accomplished by taking advantage of the design of the vessel (passive measures) and by isolating the fire from sources of fuel and oxygen (active measures). The following sections discuss these passive and active measures.

A. Passive Measures

Passive measures include features that are designed into the cutter that serve to inhibit fire growth.

1. Compartmentation

A ship is subdivided into compartments for several purposes, not the least of which is to provide barriers to fire, smoke, and flooding.

a) Barriers.

Barriers include the bulkheads, decks and overheads that define a compartment's boundaries. Watertight bulkheads are designed to resist both fire and flooding. Non-watertight joiner bulkheads serve a useful purpose to slow the spread of fire and smoke but are generally ineffective to prevent progressive flooding. Doors, windows and portholes are often open to provide ventilation and access for the crew; these must be

immediately closed in the event of fire or flooding to maximize the barriers' effectiveness. Some ships have specially designed bulkheads and decks to resist fire spread (e.g. boundaries enclosing engineering spaces). A fire zone boundary is a physical boundary designed to retard the passage of flame and smoke. Watertight bulkheads and decks may serve as fire zone boundaries along with other boundaries specifically designed to resist fire. In addition, joiner bulkheads may serve as a fire zone boundary even though there is a reduced degree of fire resistance compared to a specifically designated fire zone bulkhead/deck. These joiner bulkheads may serve as a fire zone boundary, provided there is physical integrity maintained from deck-to-deck. Any boundary in which the physical characteristics are maintained (i.e. no openings) can serve as a smoke boundary to prevent smoke spread. Openings can be protected to prevent smoke spread by installing smoke curtains or blankets/sheets.

b) Fuel Loading.

A fire cannot burn without fuel. Therefore if the fire can be isolated in a compartment that has minimal fuel loading, the fire will go out on its own. The distribution of the fuel loading is an important factor in fire growth. For example, if the fuel is stacked vertically (opposed to horizontally) the fire will grow more quickly for the same amount of fuel. Fire will also spread more quickly in bookcases with the glass doors open than with the doors closed. Simply closing the doors on bookcases before leaving the ship's office is a good example of how one can take advantage of the ship's passive fire protection features to prevent fire growth.

The type of fuel is a very important factor. There are two basic types of solid fuel: cellulosic and plastic. Cellulosic fuels are basically wood-based products such as paper, wood, and cotton. Plastics include a lot of the modern manufactured products such as polystyrene (liners in refrigerators), foams and vinyls (padding and upholstery used in cushions), and polyesters (clothing). Plastics, in general, have heat release rates that are five to ten times greater than cellulose. Sleeping bags brought on board by the crew for example, may be five to ten times more hazardous than wool blankets.

2. Construction Materials

Non-flammable construction materials are normally specified in new construction. The crew is cautioned that decorative sheathing or paneling installed during habitability improvement projects should not include flammable materials. Likewise, if the cushions on the mess deck benches are reupholstered, the selection of materials should be in accordance with guidance on acceptable products and materials. This guidance should be obtained from the Naval Engineering Manual, COMDTINST M9000.6 (Series), or from the MLC (v) division.

B. Active Measures

Active measures include actions that the ship's crew can take to isolate and contain a fire.

1. Setting Material Condition ZEBRA

One of the most basic procedures in shipboard firefighting is setting material condition ZEBRA which is intended to close all doors and windows in all the barriers to a fire.

2. Securing Ventilation

Securing supply and exhaust ventilation fans and installing available covers over the inlet or exhaust will reduce the available oxygen to a fire. Positive ventilation should be provided where possible to spaces outside the smoke boundaries.

Active desmoking (e.g. positive ventilation to spaces outside smoke boundaries and desmoking during firefighting efforts) should be limited to fires involving class A materials. Refer to NSTM Chapter 555, Section 555-5.3.4C for additional guidance and details.

3. Securing Fuel

In a class B fire it is absolutely essential to secure the fuel to operating engines. Attempts to extinguish the fire will be frustrated until the source of the fuel is secured. Remote fuel shutoffs are provided outside the machinery space to safely secure the fuel supply. It should be noted that after securing the fuel supply the engine will continue to run for a short time to consume the in-line fuel.

4. Securing Electrical Power.

Securing the electrical power will extinguish a class C fire. Additional extinguishment efforts may be required if a class A or B fire is also involved. The fire pumps on most cutters are electrically operated. Therefore an alternate source of firefighting water pressure may be required in the event electrical power is secured.

VI. Extinguishment

A. Firefighting Equipment

The firefighting systems described below are installed on Coast Guard Cutters. Each has capabilities and limitations which must be understood by firefighting personnel to ensure quick and proper selection of equipment. Each cutter has a subset of these systems and it is important to know which systems/equipment are available for use. This specific information is located in Part C of the fire protection doctrine for each cutter. The following information is a basic introduction to firefighting equipment typically found on board Coast Guard Cutters. All personnel should read the following publications for more detailed information:

- Naval Ship's Technical Manuals (Chapters 555, 077 and 079 vol 1-3)
- Naval Engineering Manual (COMDTINST M9000.6 (Series))
- Surface Ship Survivability Manual (NWP 62-1 (Series))

1. Firemain System

The firemain system consists of installed piping to distribute water to fire stations located throughout the ship. This piping may be exposed to freezing temperatures, the weight of the water in the system would adversely affect stability, and operating the fire pumps without overboard reliefs would burn up the pumps, therefore this system is normally dry and has to be charged with water from an installed electric pump or a portable pump. The system is normally used to energize fire hoses for fighting class A fires or for the production of AFFF water mixture for class B fires. When a hose line attack is needed to attack a flammable liquid fire, water fog may be used (fog position on the Coast Guard vari-nozzle) as the primary extinguishing agent. However, the time required to fight the fire will be longer, more firefighters will be required, increased fire damage can be expected, and risk of reflash is greater than if AFFF were used.

2. Firehose and Nozzle

The standard hose used on Coast Guard Cutters is an orange colored, chlorosulfonated, polyethylene (hypolon), impregnated, double jacketed, synthetic rubber hose in two sizes - 1 1/2" and 2 1/2", and one length - 50 ft. The hose is configured with a brass male coupling on one end and a brass female coupling on the other. The male end always goes to the scene of the fire. The exposed brass threads on the male coupling are easily damaged which may prevent installation of a nozzle. Two lengths may be connected and the couplings should be hand tightened. The spanner wrench at the fire station should not be used for this purpose, this wrench should be used to loosen the connection between the fire station and the firehose. Fire stations are located on the cutter such that two hoses can be brought to bear in any compartment. This may require the installation of two lengths of fire hose on some fire stations.

The Coast Guard Vari-nozzle is manufactured by Akron Brass (style 3019) and Elkhart Brass (SFL-GN-95). It is designed for a 95 gpm flow rate and is used to produce AFFF with a style 2901 inline proportioner.

3. Portable Pumps

Portable pumps serve a dual purpose. First, they may be used to provide a source of firefighting water on the cutter itself or for another vessel in distress. The portable pump can serve as a backup to the installed electric pump or as the primary source in case the electric pump is unavailable. This is often the case in an engine room fire where most electric pumps are installed. Secondly, they can be used as a means of dewatering. Since a portable pump is driven by an internal combustion engine, it must be operated on the weather deck. The designation of portable pumps includes the rate in gallons per minute the pump is designed to produce.

a) P-250 Mod 1 Pump

This pump is a portable, gasoline engine driven pump. It is designed for use in firefighting and dewatering operations. It will produce 250 gpm at 100 psi using two 1 1/2" hoses and one 2 1/2" eductor. For dewatering contaminated spaces, the P-250 pump can be used in conjunction with a peri-jet eductor; the pump can draw a suction directly

on uncontaminated spaces if the suction hose will reach the space from the weather deck. The peri-jet eductor is a venturi that is designed to discharge approximately two times the amount of water pumped through it. If the eductor discharge becomes blocked, the eductor will very quickly flood the compartment it is supposed to be dewatering. A careful and frequent check must be conducted to ensure the eductor is working satisfactorily.

b) CG P-1B Pump

These pumps are portable, lightweight, self contained pumps used for dewatering only. The CG P-1B will dewater at the rate of 120 gpm with a 10' suction lift and 20' discharge head.

c) CG P-5 Pump

The CG P-5 pump can be used for dewatering and limited firefighting and AFFF application at the rate of 200 gpm with a 10' suction lift.

4. Automated Fixed Flooding Systems

A class B fire in the engine room is capable of extremely rapid growth to major conflagration proportions in a matter of minutes if not seconds. Since it typically requires ten minutes or more for a ship to set Zebra, man repair parties, rig firehoses, and dress out a firefighting party in firefighting ensembles, an automated fixed flooding system may be installed to combat this type of problem. Magazines are usually protected by an automated fixed flooding system as well.

a) CO₂ System

Fixed CO₂ systems are installed in paint lockers, flammable liquid storerooms, and engine rooms. It is normally designed to totally flood the space and includes automatic shutdown of installed ventilation systems. The system normally includes a manually activated remote pull box, audible and visual alarms. If the space protected is normally occupied and there is a vertical exit to the weather deck, a 60 second discharge time delay is mandatory to permit evacuation of personnel since CO₂ is lethal in the concentrations required to extinguish fires. CO₂ is heavier than air and will persist in the protected space even if openings in the overhead are present.

b) Halon 1301 System

Halon 1301 is installed in the engine room since halon is extremely effective against class B fires and accidental discharge is non-lethal in the concentrations required to extinguish fires. However, if halon is ingested by internal combustion engines, or if halon is exposed to the fire itself for more than ten seconds, the byproducts from the combustion of halon are toxic to humans. Therefore the design of Halon 1301 total flooding systems include discharge times of less than ten seconds, and include automatic shutdown of internal combustion engines and ventilation equipment in the protected spaces. A 60 second time delay, visual and audible alarms, similar to CO₂ systems, are included in the design of Halon 1301 flooding systems to permit evacuation of the space before

discharging Halon. When it is released, Halon 1301 vaporizes to a colorless, odorless gas with a density approximately five times that of air. Halon concentrations between 5% and 7% are required to extinguish fires. Sufficient volume is provided to maintain this concentration for at least 15 minutes, therefore it is important to seal the protected space to prevent escape of the agent. In addition, two "shots" are usually provided that are capable of completely flooding the protected space twice. The second shot is designed to be used if the first shot is ineffective or in the event of a reflash.

c) Aqueous Film Forming Foam (AFFF)

AFFF is composed of synthetically produced materials similar to liquid detergents. For shipboard use, six parts of AFFF concentrate are mixed with 94 parts water. The bilge area in engine rooms may be protected by installed nozzles which distribute pre-mixed AFFF. AFFF, when proportioned with water provides three firefighting advantages: First, due to its low viscosity it quickly spreads over the surface of burning fuel, the aqueous film thus formed excludes air. Second, the foam layer prevents the escape of fuel vapors. Third, the water content of the foam provides a cooling effect.

AFFF is produced by mixing water with AFFF concentrate either by a fixed, balanced pressure foam proportioning unit or by using a portable 95 gpm in-line eductor (sometimes referred to as a pick-up tube) attached to one of the installed fire stations. AFFF can be applied from an installed AFFF hose reel with vari-nozzle, or from a separate fire plug fitted with portable in-line eductor and hose fitted with vari-nozzle, or from a fixed sprinkler system installed in the bilge area or the overhead.

d) Aqueous Potassium Carbonate

Aqueous potassium carbonate (APC) is used to extinguish burning cooking oil and grease in deep fat fryers and galley ventilation exhaust ducts. APC solution consists of 42.2% potassium carbonate and 57.8% water. When APC comes in contact with the burning surface, it generates a soap-like froth that excludes air from the surface of the grease or oil and thus extinguishes the fire.

5. Portable Fire Extinguishers

"First-aid" in the context of firefighting is the immediate attempt to extinguish a discovered fire. Portable extinguishers are installed throughout the ship to facilitate this effort. The location of the various types of extinguishers take into account the most likely class of fire that will occur considering the fuel loading. The following information is provided to assist in the selection of an appropriate extinguisher.

a) Carbon Dioxide (CO₂)

CO₂ is primarily used to extinguish small class C fires. They have limited effectiveness on small class A and class B fires of low heat intensity and an involved surface area of four square feet or less. A successful attack requires a close approach due to an effective range of four to six feet. Caution is required when using CO₂, especially when more than one extinguisher is used, as CO₂ displaces oxygen.

b) Purple-K-Powder (PKP)

Purple K gets its name from the purple color of the potassium (chemical symbol "K") bicarbonate chemical stored in the extinguisher. The agent is expelled under pressure from a CO₂ or nitrogen cartridge installed in the extinguisher. PKP is very effective on small, isolated class B pool fires (fires less than 10 square feet). PKP can be effective against spray fires; however the standard policy is to abandon the space, secure the source of the pressurized fuel, and utilize fixed suppression systems to combat a flammable liquid spray fire. The maximum range for a portable PKP extinguisher is 20 feet. PKP is intended for use by the unprotected operator who is in the best position to take initial action to extinguish a fire at its onset. Successful use of PKP is time critical.

6. Sprinkler Systems

Dry type sprinkler systems are installed in the magazines and the cargo hold. The systems usually consist of open orifice spray heads fitted to a hard pipe water distribution system. The spray heads are mounted in the upright position using 360 degree dispersion deflectors and sidewall type to provide complete coverage. Drain valves fitted at the lowest points of the water supply and sprinkling piping allow the system to be drained after activation. Compressed air connections are fitted downstream of the sprinkler control valves to test spray heads and to blow dry the piping free of water, scale, and foreign matter. Water supply is from the firemain system. The firemain riser cutout valve are normally open. Each protected space is served by a control valve operable by a reach rod from the damage control deck.

The primary purpose of magazine sprinkler systems is to prevent a dangerous rise of temperature within the magazine due to a fire in adjacent compartments, and secondarily, to extinguish incipient fires within the magazine involving high flash point flammable liquids or ordinary combustibles. The system is not designed nor tested to control or extinguish burning explosives or propellants. These materials typically have their own oxidizers and burn at extremely high temperatures ; in some cases underwater.

B. Personnel Protection

1. Emergency Escape Breathing Device (EEBD)

The EEBD is designed to provide breathing air and eye protection during emergency escape from areas containing toxic gases and smoke. Each EEBD has a flame retardant hood and plastic face shield. It generates 15 minutes of breathable air by means of a low pressure chemical oxygen generator. The EEBD is designed for emergency escape only and shall not be used as a piece of offensive firefighting equipment. Naval Ships' Technical Manual, chapters 077 and 079 vol. 2 provide operation and maintenance instructions.

2. Oxygen Breathing Apparatus (OBA)

The only breathing apparatus authorized for use on board cutters and boats is the Navy Type A-4 OBA. The green, self-starting, single candle type canister is the only authorized canister for use with the Type A-4 OBA. Red canisters are to be used for

training only and shall not be stored in repair lockers. Immediately after a wearer activates a canister, the timer shall be turned to 60 minutes and then turned back to 30 minutes.

If a person wearing an OBA is working alone in a smoke-filled or oxygen-deficient compartment, an insulated tending line shall be used with a tender. The tender shall wear 7500-volt rubber gloves, inside leather gloves, and rubber boots. The tender shall ground the end of the line to bare metal ships structure and be observant of signals from the OBA wearer. It is not recommended for an OBA wearer to enter a machinery space alone with a tending line due to the number of interferences. Two OBA wearers should enter the area together. If a second OBA wearer is not available, then a tending line must be used when a machinery space is entered.

3. Clothing

A fire can reach temperatures exceeding 2000 degrees Fahrenheit and produce dangerous concentrations of smoke and toxic gases. Cutters less than 133' and the 160' WLIC class have an allowance of two firefighters ensembles (FFE); larger cutters have an allowance of four FFEs. The optimum time to don a FFE is approximately 2 minutes, with another 1 to 2 minutes to don and activate an OBA. Under ideal conditions, it takes 2.5 to 5 minutes to don full personnel protection clothing. The scene leader should consider the time it takes to dress out in FFEs allows the fire to grow. In certain situations, rapid response with less protected personnel may result in quick knockdown of a fire. The scene leader makes the decision to request the FFE taking into account the tenability of the area, stage of the fire, and success of the initial attack.

The FFE consists of firefighter's coveralls, firefighter's antflash hood, damage control/firefighter's helmet, firefighter's gloves, and fireman's boots. Repair party personnel not required to wear the FFE shall wear fire retardant long sleeved uniforms/coveralls, hard shell battle helmet, antflash hood and gloves. The FFE helmet shall not be altered in any way.

Firefighting activities physically and mentally stress a firefighter. In particular, firefighters outfitted with firefighter ensembles are susceptible to heat stress. A rule of thumb is that personnel fully outfitted in a firefighting ensemble and OBA engaged in firefighting should be relieved after thirty minutes.

The aluminized firefighting suits are only used aboard flight deck equipped cutters. Description and maintenance instructions are provided in Naval Ships' Technical Manual, Chapter 077, and the Shipboard Helicopter Operational Procedures Manual, COMDTINST M3710.2.

4. Naval Firefighting Thermal Imager (NFTI)

The NFTI is a device that permits the user to see through dense smoke and light steam. It can be used to:

- Investigate reported fires
- locate the seat of a fire

- locate and facilitate rescue of injured personnel
- Set and maintain fire boundaries
- locate ignition sources during fire overhaul

The scene leader shall decide when to deploy the NFTI. The NFTI cannot "see" through glass, therefore it is not useful to determine the effectiveness of a Halon 1301 release by "looking" through a viewing port.

Naval Ships' Technical Manual, chapter 555, provides detailed operating instructions and information concerning the tactics for using the NFTI.

5. Firefinder

The Firefinder is a small, handheld, infrared heat sensor which produces an audible alarm when sensing a fire or heat source above 250 degrees F. It can be used to identify hot spots and more effectively maintain firefighting boundaries. Firefinders are sometimes found on small cutters which are not authorized an allowance for a NFTI.

VII. Post-Extinguishment Activities

Overhaul of a fire is an examination and cleanup operation. In addition, ship systems are restored to permit a ship to continue its mission if possible.

A. Desmoking

Small cutters are not equipped with portable desmoking equipment, therefore these cutters should use installed ventilation systems, natural means, or borrowed equipment for desmoking operations. The following sections describe desmoking equipment commonly found on board larger cutters.

1. Red-Devil Blower

The rated capacity of the red devil blower is 500 cfm with 200 ft of 8 inch hose attached. This blower is driven by an explosion proof motor. This blower should not be used to handle air containing explosive vapors. The ram fan discussed in the next section is appropriate for this type of problem.

2. Ram-Fan

The ram fan uses the water pressure for firefighting to drive a turbine for exhausting air. Because it is water driven it can be used below decks in confined areas and is suitable for exhausting explosive vapors.

B. Compartment Testing

The post-fire atmosphere in a compartment shall be tested in sequence for oxygen, combustible gases and toxic gases. Ventilating and retesting is required if initial test results are unsatisfactory.

C. Dewatering

Free water can dramatically impair the stability of a vessel. Every effort should be made to limit the amount of water used; for example preference should be given to the use of water fog over solid streams. Only as much water as is absolutely necessary should be used. Dewatering operations should commence as soon as possible if water is used as an extinguishing agent.

In extreme conditions, flooding and fire may occur simultaneously. The Damage Control Assistant or Commanding officer must make a judgment on the appropriate action and the priority of actions. For example, dewatering and hull repair in conjunction with a flooding emergency may require immediate attention to maintain ship stability. In this case, concurrent actions to passively contain the fire by securing boundaries should be performed as the primary efforts to address the flooding casualty are made.

D. Restoration of Ship's Systems

Electrical power should be restored as soon as possible so that installed ventilation equipment can be operated for desmoking and so that the electric fire pumps are potentially ready for use. Preference in restoring ship systems should be given to electrical power first, then main propulsion, then support systems for crew comfort such as air conditioning and other "hotel" services.

E. Examination and Investigation

The objectives of post-fire examination and investigation are to find and extinguish hidden fire and hot embers. This is an important aspect of firefighting and should be conducted as seriously as extinguishment of the fire itself. Overhaul personnel should investigate ventilation ducts and determine the extent the fire has traveled. Spaces behind paneling and false overheads should be carefully inspected. Wiring and piping penetrations in bulkheads and decks should be carefully inspected because fire can penetrate through extremely small spaces. Signs of structural weakness (especially in aluminum structures) should be reported and strengthened if necessary by shoring and other means. Finally a thorough investigation of the cause of the fire should be conducted and lessons learned documented so that similar fires can be prevented.

Fire Protection Doctrine - Part B
Policies for Firefighting on Large Cutters

Table of Contents

I. Introduction	20
II. Firefighting Philosophy and Approach.....	20
A. Prevention.....	21
B. Detection	21
C. Containment.....	22
D. Extinguishment	22
1. Underway	24
2. In Port	25
E. Post-Extinguishment Actions.....	26

Fire Protection Doctrine - Part B

Policies for Firefighting on Large Cutters

I. Introduction

The approach to firefighting is quite different depending on the classification of the cutter as large or small. "Large" Coast Guard Cutters spend extended periods of time underway, routinely operate off-shore where assistance in the first hour of a fire may not be available, and generally carry hazardous substances such as munitions, paint and flammable substances to facilitate self-sustaining operations. Moreover, the crew size is usually adequate to man multiple repair parties and the cutters' missions often include military readiness which increases the risk of fire damage from enemy action. All of these considerations distinguish these cutters from "small" cutters which generally make day trips and put into port at night. Their area of operations is close to shore where assistance is readily available and/or abandoning ship is quite feasible. Small cutters do not generally carry paint and other extremely flammable substances on board, this type of material is usually stored ashore in the cutters homeport. Small cutter crew size is minimal and often does not permit manning multiple repair parties. Finally, these cutters do not generally have a military readiness mission, therefore the fire threat from enemy action is virtually non-existent.

In the Coast Guard all vessels with a permanently assigned crew are considered cutters. The smallest cutter is a 65' WYTL Harbor Tugboat and the largest is a 399' WAGB Polar Icebreaker. Small Cutters are defined, for the purposes of fire protection doctrine, to be all cutter classes ranging in size from 65' WYTL Harbor Tugboats to 175' WLM (R) Coastal Buoy Tenders inclusive. Large Cutters are defined, for the purposes of fire protection doctrine, to be all cutter classes ranging in size from 180' WLB Ocean-going Buoy Tenders to 399' WAGB Polar Icebreakers inclusive. Therefore there are two versions of Part B, one for small cutters and one for large cutters. The purpose of Part B of the fire protection doctrine is to define the philosophical approach and policy applicable to firefighting on cutters. This approach and philosophy is guidance provided by the Commandant and is mandatory for Coast Guard Cutters. The Commandant will issue revisions to this guidance periodically. Part A of the fire protection doctrine provides information pertinent to fire science and applies to all Coast Guard Cutters. Part C of the fire protection doctrine provides firefighting procedures and tactics specific to a class of cutter. The Commanding Officer is required to tailor Part C of the doctrine (within the guidelines provided in Parts A and B) to suit the particular needs of the individual cutter.

II. Firefighting Philosophy and Approach

In very general terms, the firefighting approach on a large cutter employs the following sequence:

- The person discovering the presence of smoke or visible flames shall notify the Bridge with the location and class of fire and attempt to apply first aid on fires that are small enough to safely extinguish with a portable extinguisher.

- The Bridge shall sound the General Quarters alarm and announce the location and class of fire over the 1MC. The Bridge shall also announce that this is not a drill.
- All personnel shall immediately proceed to their assigned station as specified in the Watch Quarter and Station Bill, setting condition Zebra in route to their station.
- As directed by the scene leader, repair parties shall break out appropriate firefighting equipment, dress out in firefighting ensembles, and proceed to the scene of the fire.
- Extinguish the fire by activating installed fixed fire extinguishing systems and/or manually combat the fire directly or indirectly as directed by the scene leader
- Overhaul the fire, cool hot surfaces, test for explosive gases and a safe atmosphere, desmoke, dewater, and restore ship's systems.

On fires declared "out of control" in the engineering spaces, the general approach is to evacuate the space, secure the pressurized source of fuel, activate the installed total flooding system and prepare to reenter the space with fire hoses rigged to apply AFFF. On larger fires in other spaces the crew should combat the fire as directed by the scene leader with the installed firemain system/water, AFFF, or CO₂ depending on the class of fire. Initial efforts to combat a discovered fire (first aid) with a portable extinguisher should be attempted if the size of the fire is small enough to attempt extinguishment safely. The following sections provides guidance on the philosophy and approach that should be employed on large cutters in the various stages of firefighting from prevention through post-extinguishment activities.

A. Prevention

The Commanding Officer, Department Heads, and the Damage Control Assistant (DCA) shall make frequent inspections of the cutter for the presence of fire hazards, unauthorized stowage of flammable materials, and proper operation/installation of fire and smoke detectors. Paint and other extremely hazardous materials such as pyrotechnics and ammunition shall be stowed only in authorized compartments such as the Paint Locker, Pyrotechnics Locker and Magazines. Paint Lockers are usually protected with an installed CO₂ or Halon 1301 flooding system. Ammunition and ordnance shall only be stowed in magazines. These spaces are normally protected with a water flooding system. Flammable liquids shall only be stowed on board in designated storage tanks or designated lockers; drums of lube oil, hydraulic oil etc. shall be stowed ashore or on weather decks only.

The inspections conducted by the Commanding Officer, Department Heads, and DCA shall also determine that the installed fire protection systems and detectors are installed properly and ready for instant use. Battery powered smoke detectors shall be tested frequently to ensure the batteries have not been removed or discharged. Discrepancies discovered during these inspections shall be given the highest priority.

B. Detection

The watchstanders shall make rounds at least hourly underway and once every four hours in port of every space that has significant fuel loading to detect the presence of fire

and smoke. This inspection may be conducted in parallel with rounds conducted by watchstanders for other purposes such as security or engineering checks.

Where fixed fire alarm systems are not provided, the installation of self-contained, battery operated, smoke detectors shall be required for the protection of personnel in sick bays and berthing areas in accordance with the guidelines contained in the Naval Engineering Manual (COMDTINST M9000.6 (Series) chapter 985).

If a fire is reported, the general quarters alarm shall be sounded and the location and class of fire shall be announced over the general announcing system (1MC). The Emergency Diesel (or Gas Turbine) Generator shall be started and placed in standby. The firemain shall be pressurized and a P-250 shall be rigged and started as a backup source of firefighting water. The crew shall muster at their general quarters station.

C. Containment

Historically, the majority of high dollar value fire losses have occurred as a result of class B fires in the main machinery space. Moreover, fires can easily spread from one compartment to the next through open doors and hatches. Therefore, all doors and hatches to main machinery spaces shall be normally closed in port and underway in accordance with the material condition of readiness in effect. In addition, the crew should be constantly vigilant to control the quantity, type, and distribution of fuel loads to maximize the benefits from passive fire protection features that serve to inhibit fire growth.

The Commanding Officer/OOD shall maneuver the cutter underway to minimize the relative wind which could "fan" the fire. An important exception to this rule is for engine room fires. All fires in the engine room include the possibility of a flammable liquid spray fire, therefore the main engines shall normally be secured for all fires reported in the engine room. The Commanding Officer may delay securing the main engines due to a navigation hazard. The ship service generators shall be secured and the emergency generator placed on the line in the event of a fire in the engine room. A P-250 portable pump shall be rigged and started to provide a backup source of firefighting water pressure.

For major fires, especially where extreme heat denies access to the fire compartment, boundary cooling of surrounding bulkheads and decks is essential to prevent horizontal and vertical fire spread. Use intermittent bursts of water from a partially open vari nozzle.

The fire shall be isolated by setting material condition ZEBRA, securing ventilation, and installing all available inlet and exhaust ventilation covers. Electrical power shall be secured in the compartment where the fire was reported; however lighting in affected spaces shall be secured at the scene leader's discretion.

D. Extinguishment

Standard damage control communications shall be used in firefighting operations. The priority of communications shall be in accordance with the following list. Note, not all cutters have all of these systems and some ships may have other means of

communication, but the order of precedence still applies. This list takes into account the fact that on most large cutters the human voice cannot be heard throughout the cutter.

- Handheld Radio
- Sound Powered Phone
- Ship's Internal Phone System
- Salt and Pepper Line
- Damage Control Messages - Runners

The use of damage control wire-free communications (DC WIFCOM) is authorized to supplement, not replace, standard interior communications hard wired circuits (i.e. sound powered phones) for repair party personnel. Where DC WIFCOM is available it may be used as the primary means of communications within the repair locker organization (scene leaders and investigators). DC WIFCOM users shall continue to train in message writing to maintain their skills.

In general there are two basic approaches to extinguish fires - passive and active. The passive approach includes completely isolating the fire and letting the fire extinguish itself. This is feasible if the compartmentation permits closing all accesses to the affected compartment, the ventilation and electrical power can be completely secured, and pressurized sources of fuel can be secured. The active approach includes discharging a firefighting agent on the fire. There are two indirect attack methods and one direct attack method for applying agent on the fire:

- Manual indirect attack
- Indirect attack by activation of fixed fire extinguishment system
- Manual direct attack

A manual indirect attack is the application of water fog into the fire space through an existing access or through a hole cut in a bulkhead or overhead. When heat or other conditions deny access to the fire space, an indirect attack may improve conditions to permit reentry for a manual direct attack. Naturally venting the space may also improve conditions to permit reentry. For more specific guidance, see NSTM Chapter 555, Section 5.3.4B (ACN 2/B).

In either event it is critical that the agent used is appropriate for the class of fire. The crew should be prepared to aggressively attack the fire if the passive approach is unsuccessful or not feasible. In port, the majority of the crew may be ashore, but the inport duty section should be adequate to combat a fire at least until additional help arrives. This help may come from other ships in port or from the city fire department. Accordingly, the DCA should ensure that a plan for mutual aid is in place with other cutters and the city fire department should be invited to visit the ship for familiarity. The following sections provide specific guidance for firefighting underway and in port.

1. Underway

The person discovering a fire underway should ensure that the Bridge is notified of the fire - if necessary, before attempting to extinguish the fire. The class of fire (class A, B or C) and its location shall be passed to the Bridge so that the crew can take appropriate action. The location shall include the compartment's noun name and identification ("Engine Room, Compartment 3-46-0-E" for example).

The next step involves application of "first aid" with a portable extinguisher on fires small enough to attempt extinguishment safely. On larger fires the person discovering the fire should close all doors, hatches, windows and other accesses to the compartment to isolate the fire. Portable PKP and CO₂ extinguishers are strategically located throughout the cutter to combat Class B and Class C fires respectively. However, the immediate use of any of these extinguishers on an incipient Class A fire, while hoselines are being advanced, may control the fire and prevent a major incident. The use of these extinguishers on Class A materials may knockdown the flame, but the Class A material may quickly reignite. Table B-1 specifies the preferred agent for each class of fire. Do not attempt to extinguish a flammable liquid spray fire until the source of the pressurized fuel is secured. Do not discharge a CO₂ fire extinguisher in a small enclosed space without respiratory protection.

TABLE B-1 FIRST AID FIREFIGHTING AGENTS

CLASS	PREFERRED AGENT
A	PKP or CO ₂
B	PKP
C	CO ₂

If a Class B fire in the machinery spaces cannot be extinguished immediately with PKP, the fire shall be declared "out of control", the space shall be evacuated, pressurized fuel sources shall be secured and the installed total flooding system shall be activated. The on scene leader shall ascertain the effectiveness of the firefighting agent and recommend discharging a second "shot" of firefighting agent if available. The following actions can be used to make this determination:

- monitoring the fire through a viewing port in the door (Note NFTI cannot "see" through glass)
- monitoring temperatures in the space
- observing smoke discharging from vents
- observing paint blistering and discoloring on bulkheads

In either event, 15 minutes shall elapse before attempting re-entry to permit cooling of hot surfaces below the ignition point. Reentry shall only be attempted by

personnel properly dressed in a FFE and OBA, and prepared to apply AFFF as the primary firefighting agent.

A flammable liquid spray fire shall be automatically considered a class B fire out of control. Past experience and fire testing have shown that a pressurized release of a flammable liquid can create a fire that is unapproachable. Life threatening conditions created by extreme heat, smoke and toxic gases can occur in as little as 60 seconds. Under such conditions the only prudent course of action is to evacuate the space, secure the fuel source and activate the installed total flooding system.

An oil leak in the engine room shall be repaired immediately, a major oil leak shall be automatically considered equivalent to a class B fire. That is, it shall be reported immediately to the bridge, engines shall be secured and preparations to fight a class B fire with AFFF shall be accomplished.

The decision to secure lighting in affected spaces shall be made by the on scene leader. Every effort shall be made to mechanically and electrically (other than lighting) isolate the affected spaces. The decision to commence firefighting efforts may be made by the on scene leader before electrical isolation is complete.

Reentry into a machinery space that has been evacuated because a fire was declared out of control is the most critical and hazardous part of the firefighting evolution. The decision to reenter the space should be made only if there is reasonable evidence that the fire is out. Re-entry personnel shall be dressed out in firefighter's ensembles (FFE) and OBA including one piece coverall, gloves, anti-flash hood, helmet, and steel toed rubber boots. Re-entry teams shall use as a minimum, a single attack 1 1/2" hose, with vari-nozzle and AFFF as the primary firefighting agent. AFFF may be supplied from a balanced pressure proportioner or from 5 gallon cans using an in line eductor. Before the single attack hose enters the space, a second backup attack hose should be manned and charged to render assistance. Supply AFFF for the backup hose from 5 gallon cans using an in-line eductor. Use in-line eductors designed for use with 95 gpm vari nozzles. The primary functions of the re-entry team is to rescue trapped personnel, to ensure the fuel source is secured, to overhaul the fire, and to lay a blanket of foam on any flammable liquids to prevent a reflash. Cooling hot surfaces to prevent reignition is also a reentry function. The scene leader shall decide what resources are needed, including the need for an attack team leader with NFTI and/or the need for the backup team to enter the space. If the scene leader directs the backup team to enter the space, enough distance should be maintained between the first and second hoses to prevent maneuverability and firefighting progress from being impaired. The scene leader should consider having the backup hose team attack the fire from a different direction or access. If an additional person is available to act as an attack team leader, he should enter the space in a FFE and direct the actions of the hose team(s). The attack team leader should operate the NFTI to locate and direct the hose team(s) to the fire.

2. In Port

The local fire department (military or civilian) should be familiar with the cutter. Periodic visits should be conducted to acquaint new members of the fire department with

the cutter and its fire protection doctrine. A copy of the cutter's fire protection doctrine shall be made available to the fire department and kept up to date by the cutter.

The Coast Guard uses two types of threads in its firemain system: National Standard Hose Threads for 2.5" and larger connections, and National Pipe Straight Hose Threads for 1.5" connections. These threads may not be compatible with municipal fire departments. On cutters which do not have 2.5" topside hose connections, it is necessary to install a 2.5" male by 1.5" female adapter to the International Shore Connection (Ship). All cutters shall ensure that local fire departments have the companion flange to the International Shore Connection (Ship).

The local fire department, and other cutters in port shall be notified of any fire and assistance requested if needed.

E. Post-Extinguishment Actions

Combustible gases may be present after a compartment fire has been extinguished. Carbon monoxide will be the predominant gas generated in a class A or class C fire; substantial concentrations are required (12.5% is the lower flammable limit) before carbon monoxide will ignite. Therefore, after a class A or class C fire, desmoking with installed ventilation equipment can proceed with minimal risk. If the fire involved class B materials, the presence of flammable liquids can create a flammable atmosphere. Operating electric controllers to start ventilation fans may ignite these gases. After a class B fire, the presence of combustible gases should be assumed; desmoking with installed ventilation equipment can proceed with minimal risk under the following conditions:

- The class B fire has been extinguished
- AFFF has been used to cover flammable liquids
- The source of fuel has been secured
- The space has been allowed to cool for at least 15 minutes
- All fuel has been washed into the bilge
- No damage has been sustained to the ventilation equipment
- No damage has been sustained by the ships service generator

If desmoking with the installed ventilation system is prudent, all fans (supply and exhaust) should be operated on high speed for at least 15 minutes. Desmoking shall precede atmospheric testing because combustible gas analyzers will not operate reliably in a halon atmosphere and oxygen analyzers will not operate reliably if the sensor is exposed to excessive moisture, heat or particulate found in a post-fire atmosphere. When the space is tested for oxygen and combustible gases, oxygen shall be between 20 - 22 percent, combustible gases shall be less than 10 percent of the lower explosive limit, and all toxic gases below their threshold limit values before the space can be certified safe to enter without OBAs.

Shipboard personnel authorized to conduct post-fire atmospheric tests for the purpose of certifying the space safe for personnel are gas-free engineers and gas-free petty

officers (E-5 and above) as defined by the Naval Ships Technical Manual, Chapter 074, Volume 3. When emergency conditions exist and the gas-free engineer or gas free petty officer are not available, a performance qualification standard (PQS) qualified repair party post fire gas free test assistant may perform testing with the approval of the Commanding Officer. The repair party post-fire gas-free test assistant may not perform "safe for hot work" gas free tests unless he is qualified per the requirements of NSTM 074 vol. 3.

The extent of testing for toxic gases is dependent on the effectiveness of desmoking. When the installed ventilation system is operated on high speed for at least 15 minutes, the only toxic gas test required is for carbon monoxide. If desmoking is accomplished by less effective means, tests are required for carbon monoxide, carbon dioxide, hydrogen chloride, hydrogen cyanide, and hydrocarbons. In addition if halon has been discharged a test for hydrogen fluoride must be conducted if the installed ventilation system was not operated on high speed for 15 minutes to desmoke.

A compartment is considered safe only after satisfactory test results have been achieved at all test locations during the latest round of tests.

Besides testing the compartments for safe atmosphere, post-extinguishment activities include overhauling the fire, cooling hot surfaces to prevent a reflash, dewatering, desmoking, and restoring ship systems. In addition, shoring weakened bulkheads and decks may be required.

Fire Protection Doctrine - Part C
Procedures for Firefighting on JUNIPER

Table of Contents

I. Introduction	30
II. Vessel Characteristics	30
A. Compartmentation.....	40
1. Batteries.....	40
2. Freon	40
3. Gasoline.....	40
B. Mechanical and Electrical Isolation.....	40
1. Fire Boundaries.....	41
2. Mechanical Isolation.....	43
3. Electrical Isolation.....	43
4. Fuel Tanks	43
C. Ventilation/Smoke Control.....	44
D. Fire Detection Equipment.....	45
E. Firefighting Equipment	45
1. Firemain System.....	46
2. CO ₂ Total Flooding System.....	47
3. AFFF System	48
4. Sprinkler Systems.....	48
5. Portable Pumps	49
6. Portable Fire Extinguishers.....	51
7. Personnel Protective Equipment	51
a) Oxygen Breathing Apparatus.....	51
b) Protective Clothing	51
III. Firefighting Procedures for Class A, B, and C Fires.....	52
A. Class A Fire Scenarios.....	52
1. Scenario	52
2. Confining the Fire.....	52
3. Sizeup.....	52
4. First Aid.....	52
5. Firefighting.....	53
a) Installed Fire Extinguishing Systems.....	53
b) Manual Firefighting	53
6. Post-fire Activities.....	53
7. Other Actions.....	54
B. Class B Fire Scenarios.....	54
1. Scenario	54
2. Confining the Fire.....	54
3. Sizeup	54
4. First Aid.....	54
5. Firefighting.....	55
a) Installed Fire Extinguishing Systems.....	55

b) Manual Firefighting.....	55
6. Post-fire Activities.....	56
7. Other Actions.....	56
C. Class C Fire Scenarios.....	56
1. Scenario.....	56
2. Confining the Fire.....	56
3. Sizeup.....	56
4. First Aid.....	57
5. Firefighting.....	57
a) Installed Fire Extinguishing Systems.....	57
b) Manual Firefighting.....	57
6. Post-fire Activities.....	58
7. Other Actions.....	58
IV. Firefighting Procedures for Specific Compartments.....	58
A. Pilothouse (03-56-0-C).....	58
B. Commanding Officer's Cabin (02-57-0-L).....	58
C. Fan Room (02-73-0-Q).....	59
D. Emergency Generator Room (01-78-3-E).....	59
E. Main Machinery Room (4-66-0-E).....	60
F. Cargo Hold (2-30-0-AA).....	60
G. Electronics IC & Gyro Room (03-66-01-C).....	61
H. Auxiliary Machinery Room (4-82-0-E).....	61
I. Stern Thruster Machinery Room (4-92-0-E).....	61
J. Bow Thruster Machinery Room (4-12-0-E).....	62
K. SOR Machinery Room (2-49-0-E).....	63
L. Steering Gear Room (1-102-0-E).....	63
M. Galley (1-57-1-Q).....	63
N. Laundry (1-105-2-Q).....	64
O. Flammable Liquid Storeroom (1-6-2-A).....	64
V. In Port Fires.....	65
A. Scenario.....	65
B. Confining the Fire.....	65
C. Sizeup.....	65
D. First Aid.....	65
E. Indirect Attack.....	65
F. Direct Attack.....	65
G. Post-fire Activities.....	65
H. Other Actions.....	66

Fire Protection Doctrine - Part C

Procedures for Firefighting on JUNIPER

I. Introduction

One of the most life threatening and hazardous activities that may be encountered on board ship is fighting a fire. Unlike a building fire, the crew often can not evacuate and leave the firefighting to trained professionals. The crew must extinguish the fire, often without assistance, and using only the available equipment on board. Once a fire occurs, it is too late to read this doctrine, it is too late to obtain training, and it is too late to repair and maintain damage control equipment. Finally, the procedures in this doctrine are not a substitute for the exercise of good judgment based on experience and the particular conditions that exist at the time.

The purpose of this doctrine is to provide useful background information pertinent to fire science (Part A), guidance promulgated by Commandant for "large" classes of Coast Guard Cutters (Part B), and tactical firefighting procedures for each class of fire likely to be encountered on this class of vessel, inport and underway (Part C). Note, the Commanding Officer is responsible for tailoring Part C of this doctrine within the guidelines set forth in the following documents:

- Naval Ships' Technical Manual (NSTM) Chapter 074, Volume 3
- Naval Ships' Technical Manual (NSTM) Chapter 077
- Naval Ships' Technical Manual (NSTM) Chapter 079
- Naval Ships' Technical Manual (NSTM) Chapter 555
- FXP-4
- Surface Ship Survivability, NWP 62-1
- COMDTINST M9000.6B, Naval Engineering Manual
- The Cutter's Fire Protection Doctrine, Parts A and B
- The Cutter's Engineering Casualty Control Manual

II. Vessel Characteristics

The 225' JUNIPER is a Seagoing Buoy Tender; its primary missions include Aids to Navigation and Environmental Response. A description of the cutter's compartmentation including unusual or significant fuel loads, installed firefighting systems and a description of any access/egress problems in the cutter are also provided in this section of the doctrine.

A. Compartmentation

The following figures show the outboard profile, inboard profile and plan views of all decks. In addition doors and hatches are indicated which permit the determination of access routes for firefighting and egress routes for evacuation of personnel.

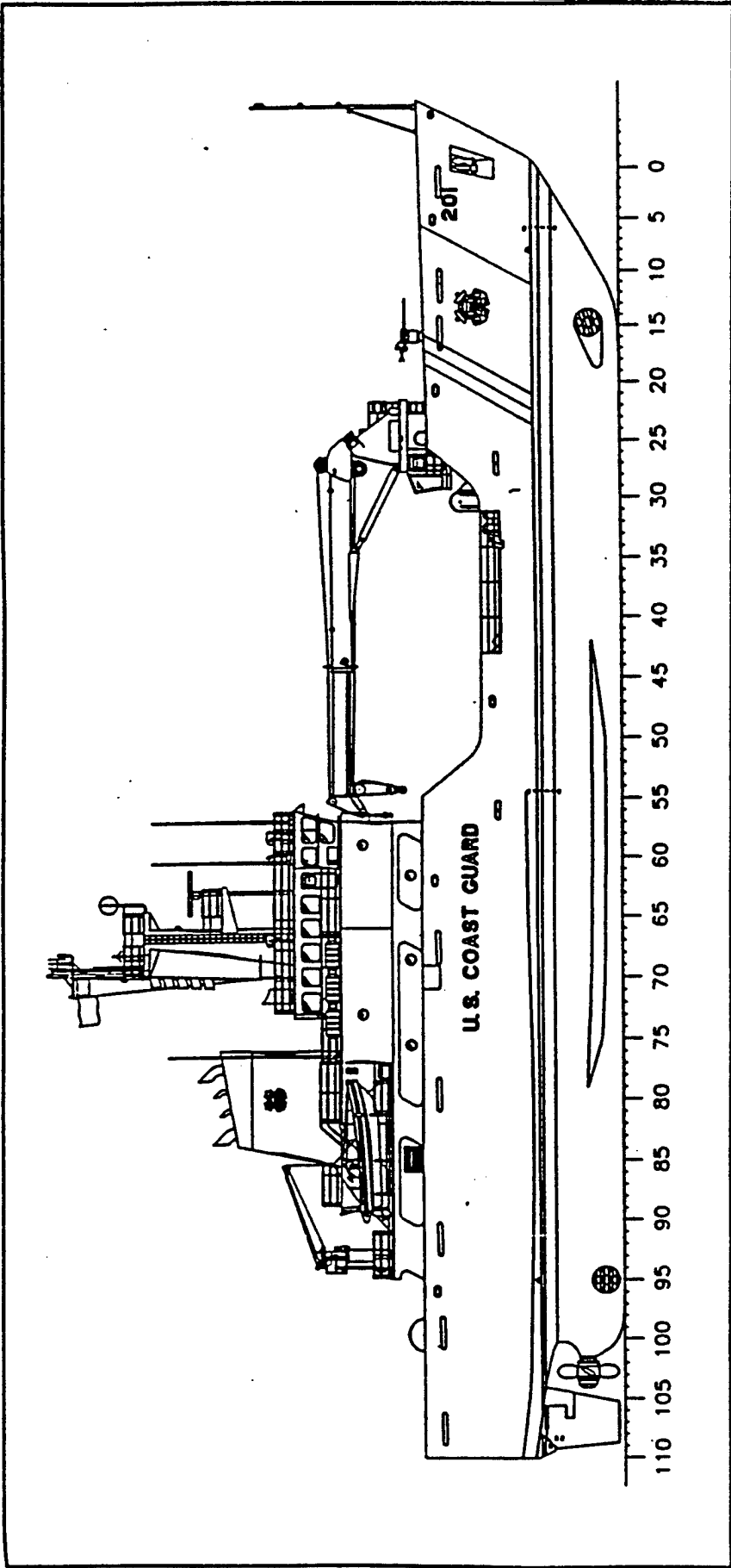

Figure 1. Outboard profile.

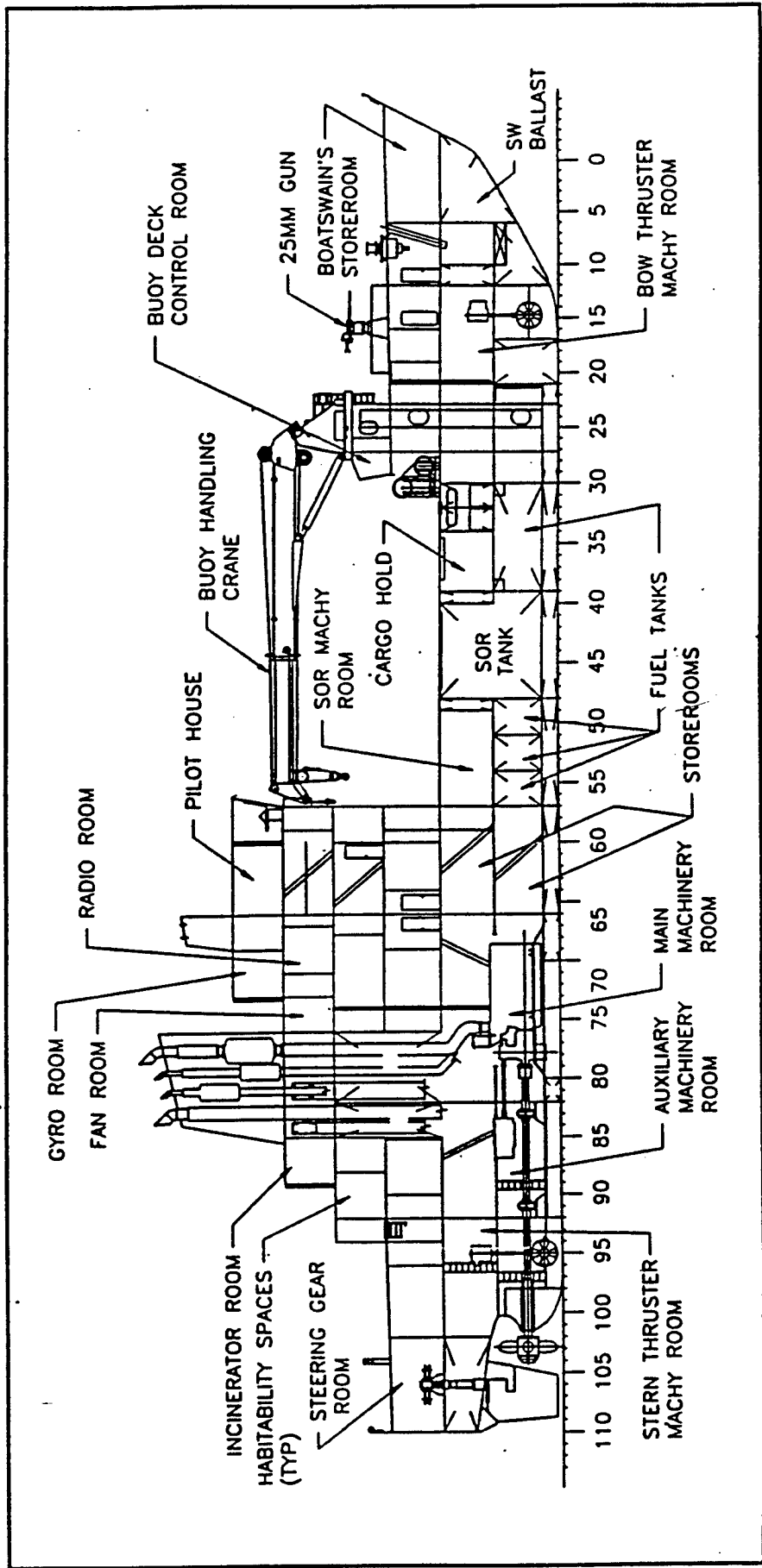
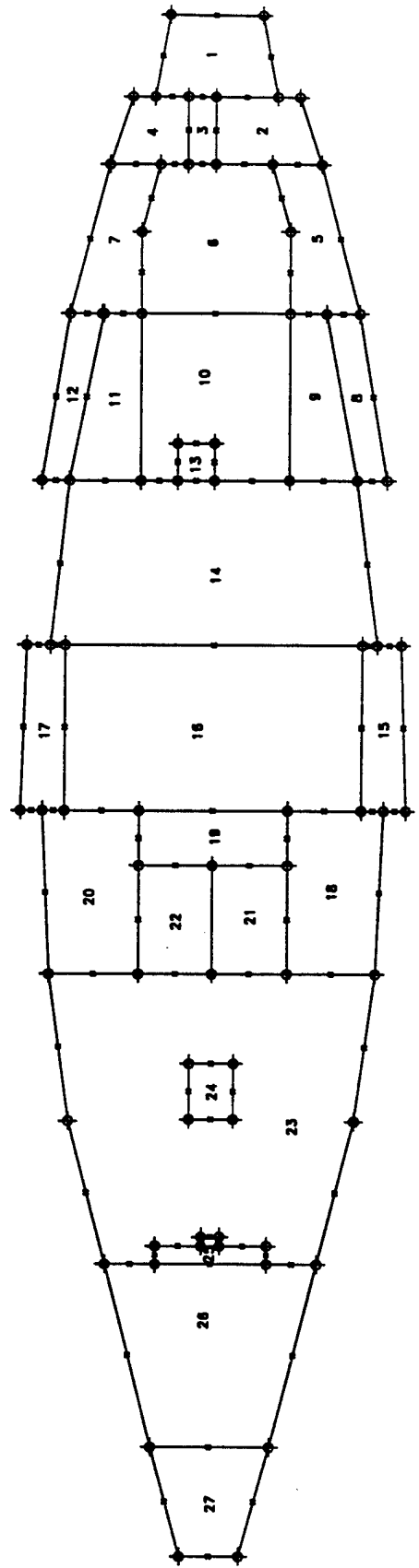

Figure 2. Inboard profile.

Plan ID	Compartment Name	Drawing Number
4-12-0-E	BOWTHRUSTER MCHRY ROOM	1
4-17-1-F	FUEL TANK	2
4-17-2-V	VOID	3
4-17-4-F	FUEL TANK	4
4-21-0C-W	SW BALLAST TANK	5
4-21-0B-W	SW BALLAST TANK	6
4-21-0A-W	SW BALLAST TANK	7
4-30-3-W	SW BALLAST TANK	8
4-30-1-F	FUEL TANK	9
4-30-0-F	FUEL TANK	10
4-30-2-F	FUEL TANK	11
4-30-4-W	SW BALLAST TANK	12
4-37-2-V	VOID	13
4-39-0-V	VOID	14
4-48-0C-W	SW BALLAST TANK	15
4-48-0B-W	SW BALLAST TANK	16
4-48-0A-W	SW BALLAST TANK	17
4-57-0C-W	SW BALLAST TANK	18
4-57-0B-W	SW BALLAST TANK	19
4-57-0A-W	SW BALLAST TANK	20
4-60-1-F	LO DRAIN TANK	21
4-60-2-F	OILY WATER TANK	22
4-66-0-E	MAIN MACHINERY ROOM	23
4-71-0-F	WASTE OIL TANK	24
4-80-0-W	SEA BAY	25
4-82-0-E	AUXILIARY MACHINERY ROOM	26
4-92-0-E	STERN THRUSTER MACHRY ROOM	27

Bottom



Plan ID	Compartment Name	Drawing Number
4-8-0A-W	SW BALLAST TANK	31
4-8-0B-W	SW BALLAST TANK	32
3-21-0-L	PASSAGE	33
3-23-0-Q	CRANE PEDESTAL	34
3-25-1-M	MAGAZINE NO. 1	35
3-25-2-M	MAGAZINE NO. 2	36
4-39-0C-V	VOID	37
3-39-0-FF	SOR TANK	38
4-39-0A-V	VOID	39
3-48-1-F	FUEL TANK	40
3-48-0-FF	CARGO FUEL TANK	41
3-48-2-F	FUEL TANK	42
3-51-0-V	VOID	43
3-54-0-F	FUEL OIL OVFL TANK	44
3-57-0-A	SUPPLY DEPT. STOREROOM NO. 2	45
3-81-1-F	FUEL SERVICE TANK	46
3-62-2-F	FUEL SERVICE TANK	47

Plan ID	Compartment Name	Drawing Number
4-12-0-E	BOWTHRUSTER MCHRY ROOM	1
4-17-1-F	FUEL TANK	2
4-17-2-V	VOID	3
4-17-4-F	FUEL TANK	4
4-21-0C-W	SW BALLAST TANK	5
4-21-0A-W	SW BALLAST TANK	7
4-30-3-W	SW BALLAST TANK	8
4-30-1-F	FUEL TANK	9
4-30-0-F	FUEL TANK	10
4-30-2-F	FUEL TANK	11
4-30-4-W	SW BALLAST TANK	12
4-37-2-V	VOID	13
4-48-0C-W	SW BALLAST TANK	15
4-48-0A-W	SW BALLAST TANK	17
4-57-0C-W	SW BALLAST TANK	18
4-57-0A-W	SW BALLAST TANK	20
4-66-0-E	MAIN MACHINERY ROOM	23
4-82-0-E	AUXILIARY MACHINERY ROOM	26
4-92-0-E	STERN THRUSTER MACHRY ROOM	27
4-0-0-W	SW BALLAST TANK	28
4-6-0C-W	SW BALLAST TANK	29
3-6-0-Q	CHAIN LOCKER SUMP	30

Innerbottom

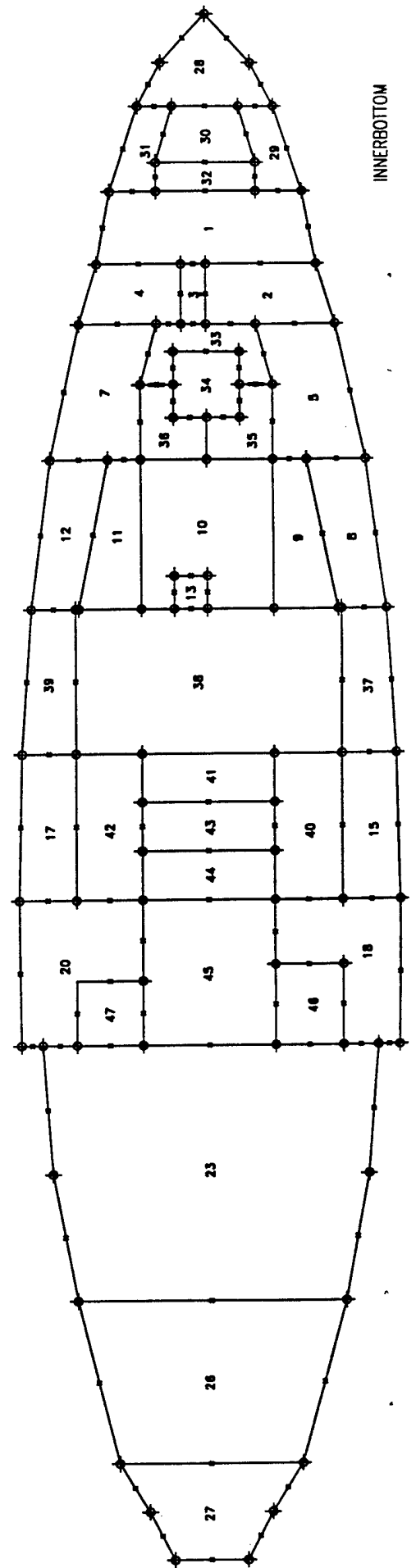

INNERBOTTOM

Plan ID	Compartment Name	Drawing Number
2-39-1-L	PASSAGE	60
2-39-0-V	COFFERDAM	61
2-39-2-V	VOID	62
2-48-1-L	PASSAGE	63
2-48-0-V	COFFERDAM	64
2-48-2-E	SOR PUMP ROOM	65
2-49-0-E	SOR MACHINERY ROOM	66
2-50-1-A	ENGINEER STOREROOM	67
2-53-1-L	VESTIBULE	68
2-57-1-Q	MACHINE SHOP	69
2-57-0-L	PASSAGE	70
2-57-2-A	SHIP STORE	71
2-57-4-E	WATER SUPPLY EQPT ROOM	72
2-59-1-Q	ELEC/EX WORKSHOP & STORER	73
2-89-1-C	ENGINEERING CONTROL CENTER	74

Plan ID	Compartment Name	Drawing Number
4-12-0-E	BOWTHRUSTER MCHRY ROOM	1
4-68-0-E	MAIN MACHINERY ROOM	23
4-82-0-E	AUXILIARY MACHINERY ROOM	26
4-92-0-E	STERN THRUSTER MACHRY ROOM	27
4-0-0-W	SW BALLAST TANK	28
4-6-0C-W	SW BALLAST TANK	29
4-6-0A-W	SW BALLAST TANK	31
3-23-0-Q	CRANE PEDESTAL	34
3-39-0-FF	SOR TANK	38
2-6-1-Q	CHAIN LOCKER	48
2-6-2-Q	CHAIN LOCKER	49
2-10-0-F	HYD OIL STG TANK	50
2-13-1-F	HPU RESERVOIR	51
2-13-2-F	HPU RESERVOIR	52
2-21-1-A	SUPPLY DEPT STOREROOM NO. 1	53
2-21-0-L	PASSAGE	54
2-21-2-Q	POTABLE WATER PUMP ROOM	55
2-25-1-WW	POTABLE WATER (CARGO)	56
2-25-2-W	POTABLE WATER (SHIP)	57
2-30-0-AA	CARGO HOLD	58
2-36-1-L	PASSAGE	59

1st Platform

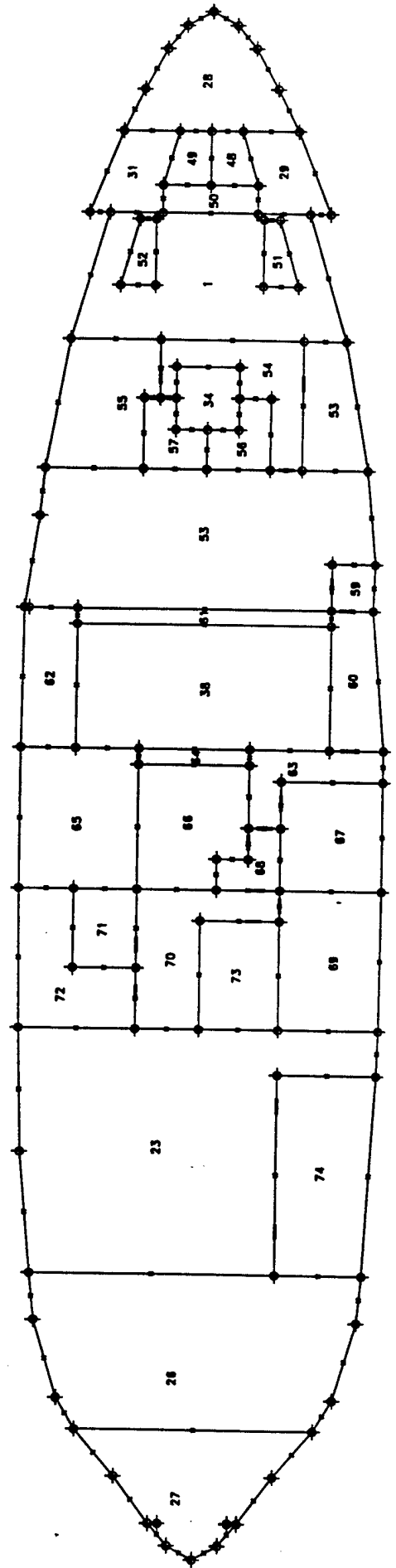

Plan ID	Compartment Name	Drawing Number
1-60-6A-A	DRY PROVISION STOREROOM	104
1-71-2-Q	ENG LOG OFFICE & DC CENTRAL	105
1-74-2-Q	DC REPAIR LKR NO. 2	106
1-76-0-Q	MMR (UPTAKE)	107
1-77-3-L	CREW LOUNGE	108
1-77-1-A	CREW LOCKER	109
1-77-2-L	CPO MESS & LOUNGE	110
1-80-1-E	VENT PLENUM	111
1-82-3-L	CREW WR, WC & SH	112
1-82-1-L	CREW WR, WC & SH	113
1-82-0-L	PASSAGE	114
1-82-2-Q	C.G. LKR W/ SINK	115
1-82-4-L	CREW WR, WC & SH	116
1-84-2-L	COMPANIONWAY	117
1-85-3-L	CREW SR	118
1-85-1-L	CREW SR	119
1-85-2-Q	AFF STN	120
1-85-4-L	CREW SR	121
1-92-1-L	CREW SR	122
1-92-0-L	PASSAGE	123
1-92-2-L	CREW SR	124
1-96-1-L	CREW WR, WC & SH	125
1-96-0-L	CREW SR	126
1-97-2-Q	FAN ROOM	127
1-97-4-L	CREW WR, WC & SH	128
1-98-1-L	CREW WR, WC & SH	129
1-102-0-E	STEERING GEAR ROOM	130
1-102-2-A	DECK GEAR STOREROOM	131
1-105-2-Q	LAUNDRY	132

Main Deck

E-36

Plan ID	Compartment Name	Drawing Number
3-23-0-Q	CRANE PEDESTAL	34
1-0-0-A	BOATSWAIN STOREROOM NO. 1	75
1-6-1-A	BOATSWAIN STOREROOM NO. 2	76
1-6-2-A	FLAM LIQ. STOREROOM	77
1-12-1B-L	PASSAGE	78
1-12-3-Q	BOATSWAIN SHOP	79
1-12-1A-L	PASSAGE	80
1-12-2-M	ARMORY	81
1-15-1-L	COMPANIONWAY	82
1-18-2-Q	AFF STN	83
1-18-4-A	ATON STRM	84
1-18-1-Q	D.C. REPAIR LKR NO. 1	85
1-19-2-T	ESC TRUNK	86
1-21-3-L	COMPANIONWAY	87
1-21-1-L	VESTIBULE	88
1-21-2-Q	ATON SHOP	89
1-57-1-Q	GALLEY	90
1-57-3-Q	DUMBWAITER TRUNK	91
1-57-0-L	DECK WR & WC	92
1-57-2-L	PASSAGE	93
1-57-4-Q	CHANGE ROOM	94
1-59-2-L	COMPANIONWAY	95
1-60-1-L	GALLEY WR & WC	96
1-60-2-A	CHILL STRM	97
1-60-4-A	FREEZE STRM	98
1-60-6B-A	DRY PROVISION STOREROOM	99
1-66-3-Q	SCULLERY	100
1-66-1-Q	GALLEY ANNEX	101
1-66-0-L	CREW MESS	102
1-66-2-L	COMPANIONWAY	103

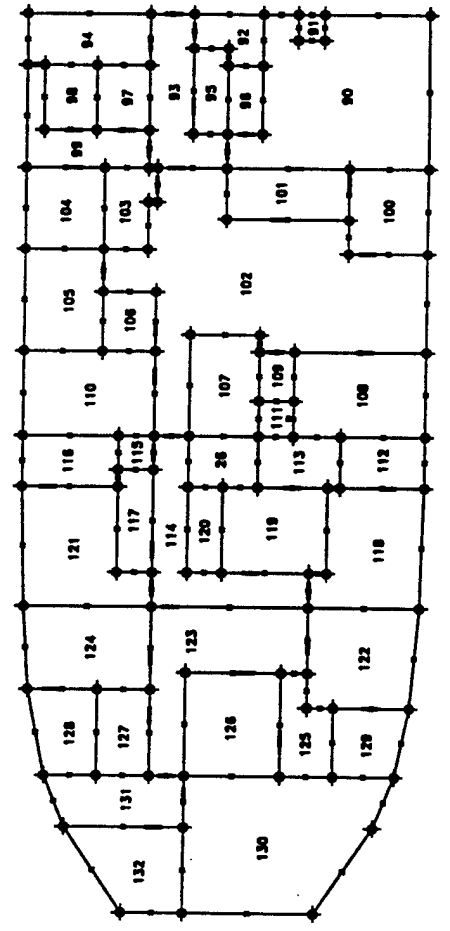

Part C

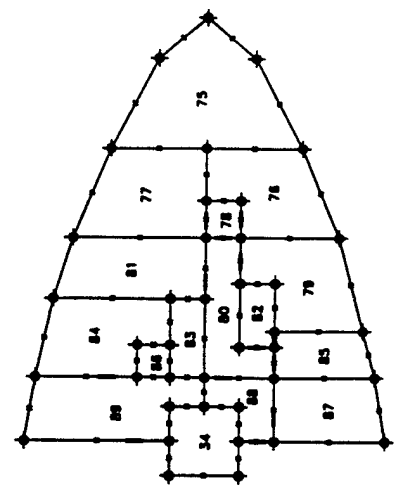

MAIN DECK

01 Level

Plan ID	Compartment Name	Drawing Number
1-57-3-Q	DUMBWAITER TRUNK	91
1-76-0-Q	MMR (UPTAKE)	107
01-27-0-C	BUOY DECK CONTROL BOOTH	133
01-57-0-Q	WARD ROOM PANTRY	134
01-57-2-L	CPO SR	135
01-57-4-L	CPO WR, WC, SH	136
01-60-1-L	WARDROOM MESSROOM & LOUNGE	137
01-60-0C-L	PASSAGE	138
01-83-2-L	CPO SR	139
01-60-0B-L	PASSAGE	140
01-66-2-L	PASSAGE	141
01-68-1-L	MEDICAL TREATMENT ROOM	142
01-68-0-Q	SHIP OFFICE	143
01-60-0A-L	PASSAGE	144
01-70-2-Q	C.G. LKR	145
01-71-2-L	CPO WR, WC, SH	146
01-74-1-L	MEDICAL TREATMENT WR, WC & SH	147
01-74-2-L	CPO SR	148
01-78-3-E	EMERGENCY GENERATOR ROOM	149
01-78-1-F	EMERGENCY GEN SERVICE TK	150
01-79-0A-L	PASSAGE	151
01-80-0-L	CREW SR	152
1-60-1-Q	VENT PLENUM	153
01-84-2-L	CREW WR, WC & SH	154
01-79-0B-L	PASSAGE	155
01-85-2-Q	FOUL WEATHER GEAR LKR	156
01-86-1-L	CREW SR	157
01-88-1-L	CREW WR, WC & SH	158
01-88-0-L	CREW SR	159
01-88-2-L	CREW SR	160
01-92-0-L	COMPANIONWAY	161

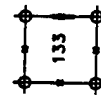
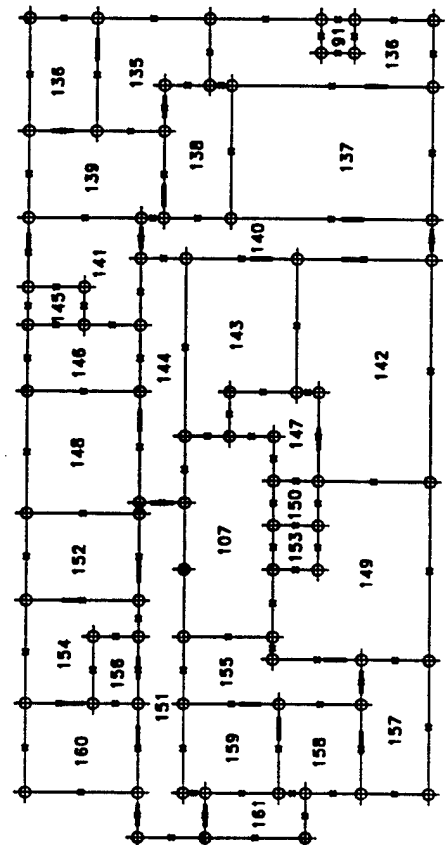

02 Level

Plan ID	Compartment Name	Drawing Number
1-76-0-Q	MMR (UPTAKE)	107
1-80-1-Q	VENT PLENUM	153
02-57-1-L	CO SR	162
02-57-0-L	CO CABIN	163
02-57-0C-L	PASSAGE	164
02-57-2-L	XO WR, WC, SH	165
02-57-4-L	XO SR	166
02-59-2-L	COMPANIONWAY	167
02-61-2-L	COMPANIONWAY	168
02-63-2-L	OFFICER SR	169
02-63-1-L	CO WR, WC, SH	170
02-66-1-L	OFFICER WR, WC, SH	171
02-66-0-C	RADIO ROOM	172
02-66-2-L	OFFICER WR, WC, SH	173
02-66-4-L	OFFICER WR, WC, SH	174
02-69-1-L	OFFICER SR	175
02-69-2-Q	CG LKR W/SINK	176
02-69-4-L	OFFICER SR	177
02-57-0A-L	PASSAGE	178
02-57-0B-L	PASSAGE	179
02-73-0-Q	FAN ROOM	180
02-75-1-Q	PFD & SURVIVAL SUIT LOCKER	181
02-75-2-Q	PFD & SURVIVAL SUIT LOCKER	182
02-85-0-Q	INCINERATOR ROOM	183

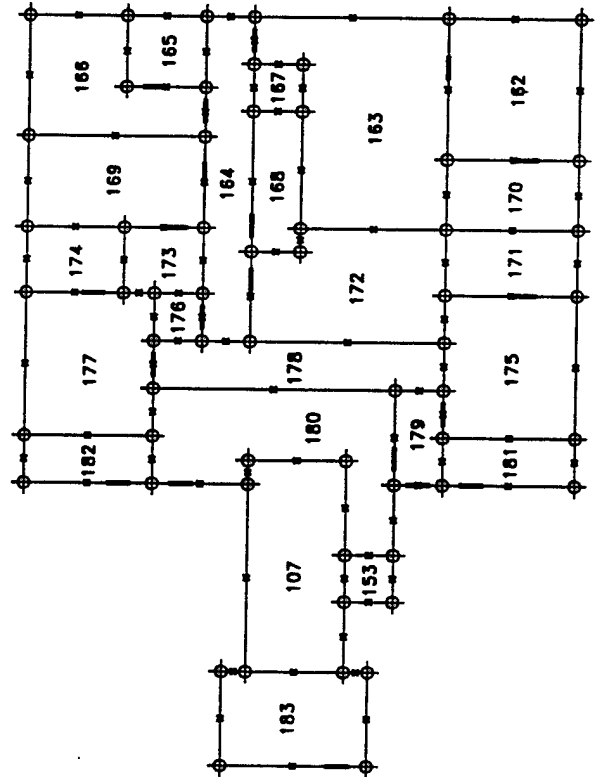

03 Level

Plan ID	Compartment Name	Drawing Number
03-56-0A-C	PILOT HOUSE	184
03-56-0B-C	PILOT HOUSE (CHART AREA)	185
03-66-0-L	DECK WR & WC	186
03-66-01-C	ELEX. IC & GYRO ROOM	187
03-76-0-Q	STACK	188

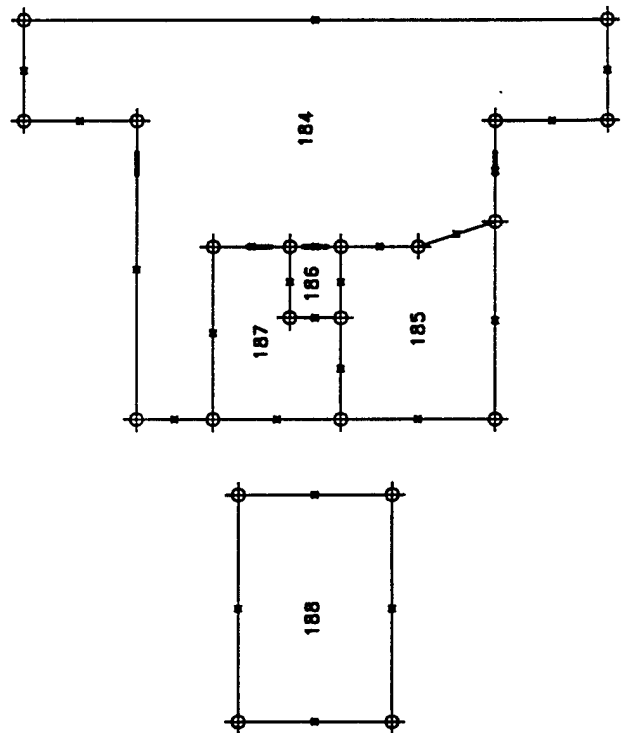

1. Batteries

Lead acid batteries can be a serious hazard during and after a fire. Hydrogen gas given off by batteries is explosive and combustible. As the batteries become hotter, more gas is given off and the danger increases. The acid in the batteries is very corrosive and can damage the ship and harm the firefighters. Using water on a battery fire can also cause an explosion. Additionally, when salt water and sulfuric acid are mixed they give off chlorine gas, which is toxic. Lead acid batteries are located as follows:

- Main Machinery Room (4-66-0-E), upper level near ladder (24 volt batteries for starting MDEs).
- Emergency Generator Room (01-78-3-E), near exhaust louvers (8 volt batteries for starting EDG and CO₂ discharge).
- Electronics IC & Gyro Room (03-66-01-C), across from the 1MC amplifier (nickel cadmium 24 volt batteries for gyro)
- Rigid Hull Inflatable Boats (02 Weather Decks), port and starboard side boat decks (12 volt for starting boat engines)

2. Freon

Freon is used as the refrigerant in air conditioning systems as well as in refrigerators and other cooling units such as frozen food storage lockers, chill boxes, etc. Freon, when exposed to fire, gives off phosgene gas which is extremely hazardous.

3. Gasoline

Gasoline is used in P-250 and P-I portable pumps. Gasoline is stowed in the canisters with the P-I pumps and on jettison racks on the weather deck.

B. Mechanical and Electrical Isolation

Space isolation is necessary to prevent fires from intensifying due to the addition of flammable liquids or oxygen and to reduce electrical hazards. Before a Class B fire in a machinery space grows out of control, the affected space should be isolated with the exception of firefighting systems, lighting and ventilation. Once the fire is out of control, secure all systems with the exception of lighting if possible.

1. Fire Boundaries

Establishment of fire boundaries is the first priority after ZEBRA has been set to confine the fire and designate bulkheads and decks that should be checked for heat. These boundaries are generally watertight however the minimum degree of tightness for a fire boundary is fumetight. A list of primary and secondary fire boundaries for machinery spaces is shown in table C.1

Table C.1 Primary and Secondary Fire Boundaries for Machinery Spaces

Compartment	Forward	Aft	Above	Below
Main Machinery Room (4-66-0-E) Primary	BHD 66	BHD 82	Main Deck	Hull
	BHD 57	BHD 92	Main Deck	Hull
Auxiliary Machy Room (4-82-0-E) Primary	BHD 82	BHD 92	Main Deck	Hull
	BHD 66	BHD 102	Main Deck	Hull
Emergency Gener. Rm (01-78-3-E) Primary	BHD 78	BHD 85	02 Deck	Main Deck
	BHD 66	BHD 102	02 Deck	Main Deck
Bow Thrust. Machy Rm (4-12-0-E) Primary	BHD 12	BHD 21	Main Deck	Hull
	BHD 6	BHD 30	Main Deck	Hull
Stern Thrust. Machy Rm (4-92-0-E) Primary	BHD 92	BHD 102	Main Deck	Hull
	BHD 82	Stern	Main Deck	Hull

2. Mechanical Isolation

Every effort should be made to secure and/or isolate systems, machinery, and tanks having the potential to feed or otherwise contribute to the intensity of the fire. Not all systems have remote securing or isolation capabilities. Along with other concurrent firefighting actions, locally secure those systems without remote securing capability as soon as possible. Capabilities and procedures are outlined in the Engineering Casualty Control Manual, NSTM chapter 079, Volume 3 and applicable machinery operating manuals. Fuel oil, lube oil, hydraulic oil, and compressed air systems are of particular concern. Systems to secure include in order of priority:

- Fuel oil service, fill & transfer systems and pumps
- Lube oil systems and pumps
- Hydraulic oil systems and pumps
- Lube oil Tanks
- Compressed air systems, compressors, and receivers

- Fuel oil tanks

Table C.2 lists all items that should be secured in the four machinery spaces. Note ventilation fans will be secured automatically in the Main Machinery Room and Auxiliary Machinery Room if the CO₂ total flooding system for the space is activated.

Table C.2 Mechanical and Electrical Isolation of Machinery Spaces

System/Components	Location	Local/Remote
Main Machinery Room (4-66-0-E)		
Both MDEs	2-69-1-C	Remote
Port/Stbd F/O Service Tanks	2-69-1-C	Remote
Both SSDGs	2-69-1-C	Remote
#1 Fire Pump	01-78-3-E	Remote
#1 Air Compressor	01-78-3-E	Remote
Red Gear L/O Pump	01-78-3-E	Remote
Supply & Exhaust Vent Fans	4-66-0-E	Local
Auxiliary Machy Rm (4-82-0-E)		
SORS Boiler	2-69-1-C	Remote
SORS Heating Pump	2-69-1-C	Remote
Stbd F/O Service Tank	2-69-1-C	Remote
Both A/C Units		
Vacuum System		
#2 Fire Pump	2-69-1-C	Remote
Both Auxiliary S/W Pumps	2-69-1-C	Remote
Grey Water Pump		
Hydraulic Oil Purifier Pump		
Chill Water Pumps	2-69-1-C	Remote
CHT Sewage Pump		
Supply and Exhaust Vent Fans		
Starting Air Receivers		

Table C.2 Mechanical and Electrical Isolation of Machinery Spaces (continued)

System/Components	Location	Local/Remote
Stern Thruster Machy Rm (4-92-0-E)		
Both HPU Units	2-69-1-C	Remote
SCR Controller & Thruster Motor	4-82-0-E	Remote
Ships Service Air Receiver	4-92-0-E	Local
Supply Vent Fans		
Bow Thruster Machy Rm (4-12-0-E)		
Both HPU Units	2-69-1-C	Remote
SCR Controller & Thruster Motor	4-82-0-E	Remote
Hydraulic Motor Transfer Pump	4-12-0-E	Local
Supply and Exhaust Vent Fans		

3. Electrical Isolation

Do not secure lighting and electrical power to firefighting equipment and ventilation before evacuation of personnel. Complete electrical isolation of many spaces is impractical due to the large number of electrical cables transiting through the space. To the extent possible, all electrical equipment will be secured from outside the affected space at the cutters service, load center(s) or distribution power panel(s). Unless directed by the scene leader do not secure lighting.

4. Fuel Tanks

Transferring fuel from the fire area puts the empty fuel tank at maximum risk to fire. Therefore, **transfer of fuel from the fire area shall not be attempted. Pressing up the vapor space in a fuel tank with seawater shall not be done**, because experience shows that ignition rarely occurs. In fuel tanks exposed to fire, conditions for ignition within the tank are unlikely, and no accurate method exists to verify the vapor space has been eliminated. In addition, the fuel tank will become contaminated with seawater. In summary, the only action necessary to prevent a fuel tank from contributing to a fire is to isolate and secure the fuel system.

C. Ventilation/Smoke Control

In general, supply ventilation shall be secured and exhaust ventilation shall be energized in the compartment where a fire has been reported. However all ventilation fans are automatically shut down in machinery spaces with CO₂ total flooding systems if the

system is activated. Fire and smoke boundaries shall be set around the affected compartment immediately after all personnel have been evacuated. **Once fire and smoke boundaries have been established only personnel outfitted with OBAs are permitted to enter the affected area.** Smoke curtains may be used where hatches and doors may be required to remain open for firefighting purposes. The locations designated for smoke curtains are listed in Table C.3.

Table C.3 Designated Smoke Curtain Locations

Compartment	Closure Fitted with Smoke Curtain
Main Machinery Room (4-66-0-E)	Joiner Door 1-66-2
Auxiliary Machinery Room (4-82-0-E)	Joiner Door 1-89-2
Companionway (1-59-2-L)	Joiner Door 1-63-2
Steering Gear Room (1-102-0-E)	QAWTD 1-103-2
Companionway (02-61-2-L)	Joiner Door 02-66-2
Companionway (01-92-0-L)	Joiner Door 01-93-2

D. Fire Detection Equipment

The fire and smoke detection system is designed to provide both audible and visual signals when fire or smoke is detected throughout the cutter's 11 designated fire detection zones. The fire and smoke detection system is a "Pyrotronics, System 3". The types of detection devices include smoke (ionization), thermal, photoelectric, and flame detectors. The location of the alarm/annunciator panel is in the Pilothouse (03-56-0-C), frame 66.

If an alarm is not acknowledged (silenced or reset when the system alarm sounds) at the control panel in the Pilothouse within two minutes, the control panel will automatically activate the cutter's general alarm.

Smoke detectors in the system have self-compensating dual ionization chambers. One chamber detects the products of combustion while the other serves as a reference to stabilize the detector's sensitivity for changes in environmental conditions. Photoelectric smoke detectors operate on the light scattering principle and have a cleanable photo chamber. Each unit is made up of a light emitting diode (LED) and light sensing photodiode. The photodiode is arranged so that light emitted by the LED does not reach the photoelectric cell. Flame detectors sense infrared radiation given off by flames when the source is sustained for at least 5 to 20 seconds. In response to a flame, a voltage is generated by the cell and amplified by a transistor amplifier-rectifier circuit. The thermal fire detectors are explosion proof. Each unit is hermetically sealed in a stainless steel shell. The outer shell is made of a rapidly expanding alloy which responds to changes in ambient temperature. The inner struts are made of an alloy with a lower coefficient of expansion.

The quantity, type, and location of the detectors presently installed in the JUNIPER are listed in enclosure 12 to JUNIPER Instruction M9555.1.

E. Firefighting Equipment

1. Firemain System

The firemain system is a dry system. It is energized by one or both fire pumps in the event of a fire. The two fire pumps are also used for ballasting and dewatering (with eductors in the bilge areas). Each of the centrifugal fire pumps is driven by an electric motor and has a discharge capacity of 650 gpm at 150 psi. Each pump has the capacity, pressure, volume and flow to support the simultaneous operation of the aft AFFF station Main Machinery Room sprinkler system, two firefighting stations (each at a flow rate of 93 gpm), and either the Main Machinery Room or the Auxiliary Machinery Room 205 gpm dewatering eductor.

The #1 fire pump is located in the Main Machinery Room (4-66-0-E), second level, frame 74, starboard side. The #1 fire pump is energized from controller PA-1 located adjacent to the pump. The #2 fire pump is located in the Auxiliary Machinery Room (4-82-0-E), frame 90, lower level. The #2 fire pump is energized from controller PA-2 located adjacent to the pump. Both controllers have a start and stop push button, a LOCAL/REMOTE selector switch, a white "power available" light, and a green "motor running" light. Seven remote controllers are wired to each fire pump controller. These remote controllers permit the fire pumps to be operated from the spaces shown in Table C-4

Table C-4 Locations of Fire Pump Remote Controllers

1. Pilothouse (03-56-0-L)
2. MPCMS console ECC (2-69-1-C)
3. Forward AFFF Station (1-16-2-Q)
4. Aft AFFF Station (1-85-2-Q)
5. Damage Control Power Panel
6. Main Machinery Room (4-66-0-E) AFFF Hose Station, Upper Level
7. Auxiliary Machinery Room (4-82-0-E) AFFF Hose Station, Upper Level

The firemain is located on the damage control deck. The single main spans from frame 20 to frame 92 and is divided into sectors. The firemain is arranged so that damage to one sector does not affect the other. Sector one of the firemain is eight inches in diameter and spans from frame 20 to frame 75. Sector two is six inches in diameter and

spans from frame 75 to frame 92. There are 21 firemain stations located throughout the cutter as shown in Table C.5, to facilitate a two-hose attack in all compartments.

Table C.5 Firemain Stations

Sector No.	Location
1	Passageway (02-57-01-L)
1	01 Deck , port side
1	01 Deck, starboard side
1	Boatswain Storeroom No. 2 (1-6-1-A)
1	Passageway (1-12-1-L)
1	Forward Buoy Deck, starboard side, frame 25
1	Aft Buoy Deck, port side, frame 57
1	Aft Buoy Deck, starboard side, frame 57
1	Passageway (1-57-2-L)
1	Crews Mess (1-66-0-L)
1	Bow Thruster Machinery Room (4-12-0-E)
1	Cargo Hold (2-30-0-AA), starboard side, frame 30
1	Cargo Hold (2-30-0-AA), starboard side, frame 39
1	Passageway (2-48-1-L)
1	Passageway (01-66-2-L)
2	03 Deck, port side
2	03 Deck, starboard side
2	Main Deck, port side, frame 90
2	Main Deck, starboard side, frame 90
2	Passageway (1-92-01-L)
2	Stern Thruster Machinery Room (4-92-0-L)

2. CO₂ Total Flooding System

The Emergency Generator Room (01-78-3-E), Flammable Liquid Storeroom (1-6-2-A), Main Machinery Room (4-66-0-E), and the Auxiliary Machinery Room (4-82-0-E) are protected by individually activated installed CO₂ total flooding systems. The CO₂ systems are Ansul, model CV-90. The actuating systems are mechanical and cannot

automatically discharge. With the exception of some electrically powered alarms, the CO₂ systems remain fully operational without electrical power for 24 hours.

Each protected compartment is provided with at least one actuation station with pneumatically actuated switches located as close as possible to a main access. These switches automatically shut down ventilation fans and diesel engines (with the exception of the emergency diesel generator) and energize alarms. The alarms consist of a siren designed to be heard above ambient noise in the compartment, and a rotating high intensity beacon. Each protected compartment are equipped with 30 second time delays located outside the protected compartment. Time delays have a manual release or bypass valve to override the time delay. CO₂ manual pull stations are located as shown in Table C.6

CAUTION: CO₂ will displace the oxygen in a compartment and an OBA must be worn until the compartment has been checked to determine that the oxygen content is normal.

Table C.6 CO₂ Pull Station Locations

CO₂ Pull Box Location	Compartment Protected
Passageway (01-79-0-L), frame 86	Emergency Generator Room (01-78-3-E)
Passageway (1-12-1-L), frame 9	Flammable Liquid Storeroom (1-6-2-A)
Passageway (1-12-1-L), frame 13	Flammable Liquid Storeroom (1-6-2-A)
Companionway (1-66-2-L), frame 68	Main Machinery Room (4-66-0-E)
Crews Mess (1-66-0-L), frame 69	Main Machinery Room (4-66-0-E)
Passageway (1-82-0-L), frame 87	Auxiliary Machinery Room (4-82-0-E)
Companionway (1-84-2-L), frame 87	Auxiliary Machinery Room (4-82-0-E)

3. AFFF System

Two Ansul, model PL-120 fixed AFFF systems are provided to protect machinery spaces from Class B fires. Each system consists of the following:

- fixed AFFF proportioning station
- bilge sprinkling nozzles
- overhead sprinkling nozzles
- hose stations

The two permanently installed AFFF proportioning stations are installed on the damage control deck (main deck). The aft station is on the centerline, aft of the Uptake (1-85-2-Q), and is energized from power panel 1-70-2. The forward station is on the centerline, in the Vestibule (1-21-1-L), and is energized from power panel 1-21-1. The

proportioning stations are designed to operate with a foam to water ratio of 3 to 5%, between 50 gpm and the maximum flow demand of the largest AFFF sprinkling system. The AFFF concentrate tanks (40 gallons forward and 75 gallons aft) are designed with enough volume to supply the AFFF system for 10 minutes with the system operating at maximum flow demand.

The Main Machinery Room (4-66-0-E), Auxiliary Machinery Room (4-92-0-E), and the Bow Thruster Machinery Room (4-12-0-E) are equipped with AFFF hose stations within the space located as close to the space's point of exit as possible. Stations are located such that one hose supplies coverage for the entire space.

AFFF hose stations located on the main deck are designated reentry stations. Reentry stations are used to service not only the spaces they are located in but also adjacent spaces such as the Stern Thruster Machinery Room, SORS Pump Room, and SORS Machinery Room. The reentry stations are equipped with a portable 95 gpm in-line eductor and two 5-gallon pails of AFFF concentrate.

4. Sprinkler Systems

Dry type sprinkler systems are installed in the Cargo Hold and Magazines. The firemain riser cutout valves for these systems are located in Passageway (1-12-0-L). These valves are normally open. The control valve for the Cargo Hold sprinkler system is located in Passageway (2-21-0-L), forward of Bulkhead 30. The valve is fitted with a reach rod and is operable from the damage control deck (main deck) in the Vestibule (1-21-1-L). The control valve for the Magazine No. 1 sprinkler system is located in Passageway (3-21-0-L), forward of Bulkhead 25. The valve is fitted with a reach rod and is operable from the damage control deck (main deck).

5. Portable Pumps

JUNIPER has two P-250 Mod 1 pumps. These pumps are water cooled, gasoline powered, portable pumps suitable for firefighting or dewatering purposes. They are capable of pumping 250 gpm of uncontaminated water. One is stowed on the forward Buoy Deck, starboard side, and the other is stowed fantail, 01 Deck, port side. The portable gasoline cans for these pumps are stowed on the starboard side of the 02 Weather Deck. A remote release to jettison the gasoline over the side is located on the starboard side of the 01 Deck.

In addition to P-250 portable pumps JUNIPER has two P-1 pumps located on the 02 Level. These pumps are used primarily for dewatering and are capable of pumping 125 gpm. They are stored in waterproof containers that will float if dropped overboard. In an emergency they can be used as a secondary means of firefighting.

JUNIPER has two portable, electrical, submersible pumps that are capable of pumping 140 gpm against a 50 foot head. These pumps are also primarily intended for dewatering, but they can be used in an emergency for low pressure firefighting. These pumps are plugged into 440 volt dedicated outlets.

6. Portable Fire Extinguishers

Portable CO₂, PKP and AFFF fire extinguishers are located throughout the cutter as shown in Table C.7. This table is partially incomplete because not all AFFF portable extinguishers have been received and installed.

Portable CO₂ extinguishers have a 15 pound capacity and an effective range of four to six feet. They are designed to attack a fire which is less than four square feet in size. A total of 28 CO₂ extinguishers are listed in Table C.7.

CAUTION: CO₂ will displace the oxygen in a compartment, use of a portable CO₂ extinguisher in a confined space without an OBA could be extremely hazardous.

Portable PKP extinguishers have an 18 pound or 27 pound capacity as shown in table C.7 and a maximum range of 20 feet. PKP is designed for use on small class B fires; it is not designed to combat spray fires, fires out of control nor should they be used for reentry. A total of 38, 18 pound PKP extinguishers and four 27 pound PKP extinguishers are listed in Table C.7.

CAUTION: PKP must be dispensed properly to avoid reduced visibility and breathing difficulties. Do not discharge PKP into electrical equipment as serious corrosion of components will occur.

Portable AFFF fire extinguishers are used primarily as first aid for combating small Class B fires such as small bilge or deep fat fryer fires before they get out of control. Table C.7 lists the locations of portable AFFF extinguishers.

Table C.7 Locations of Portable Extinguishers

Location	CO ₂	PKP	AFFF
DC Repair Locker No.1 (1-18-1-Q)	2 - 15 lb	1 - 27 lb	1-2.5 gal
DC Repair Locker No.2 (1-74-2-Q)	2 - 15 lb	1 - 27 lb	
Pilothouse (03-56-0-C)	1 - 15 lb		
Passageway (02-57-01-L)	1 - 15 lb	2 - 18 lb	
Incinerator Room (02-85-0-Q)	1 - 15 lb	2 - 18 lb	
Buoy Deck Control Booth (01-26-0-C)	1 - 15 lb		
Passageway (01-79-0-L)	2 - 15 lb	2 - 18 lb	
AtoN Shop (1-21-2-Q)	1 - 15 lb	1 - 18 lb	
Passageway (1-12-1-L)	1 - 15 lb		
Passageway (1-92-0-L)	3 - 15 lb	2 - 18 lb	

Table C.7 Locations of Portable Extinguishers (continued)

Location	CO₂	PKP	AFFF
Crew's Mess (1-66-0-E)	1 - 15 lb	1 - 18 lb	
Deck Gear Storeroom (1-102-2-A)	1 - 15 lb		
Bow Thruster Machy Rm (4-12-0-E)	1 - 15 lb	2 - 18 lb	
Passageway (2-21-0-L)	1 - 15 lb		
SORS Pump Room (2-48-2-E)	1 - 15 lb	2 - 18 lb	
Passageway (2-36-1-L)	2 - 15 lb		
Water Supply Equip Rm (2-57-4-E)	1 - 15 lb	1 - 18 lb	
Main Machinery Room (4-66-0-E)	2 - 15 lb	2 - 18 lb, 1 - 27 lb	
Auxiliary Machy Room (4-82-0-E)	2 - 15 lb	2 - 18 lb, 1 - 27 lb	
Stern Thruster Machy Rm (4-92-0-E)	1 - 15 lb	2 - 18 lb	
Flammable Liquid Storerm (1-6-2-A)		1 - 18 lb	
Galley (1-57-1-Q)		1 - 18 lb	
Wardroom Pantry (01-57-0-Q)		1 - 18 lb	
Steering Gear Room (1-102-0-E)		2 - 18 lb	
SORS Machy Room (2-49-2-E)		2 - 18 lb	
Crew Lounge (1-77-3-L)		1 - 18 lb	
CPO mess & Lounge (1-77-2-L)		1 - 18 lb	
Wardrm Mess & Lounge (01-60-1-L)		1 - 18 lb	
Laundry (1-105-2-Q)		1 - 18 lb	
Boatswain Shop (1-12-3-Q)		1 - 18 lb	
Emergency Generator Rm (01-78-1-E)		2 - 18 lb	
Machine Shop (2-57-1-Q)		1 - 18 lb	
Elec/Elex Wkshop & Strm (2-59-1-Q)		1 - 18 lb	
Change Room (1-57-4-Q)		1 - 18 lb	

7. Personnel Protective Equipment

The proper use of personnel protective clothing, equipment and procedures is necessary to reduce the risk of injury and help extinguish the fire. The nozzle men and hose tenders on each hose team (and the team leader) shall wear fire fighter ensembles. Repair locker leaders are responsible for rotating personnel to prevent heat exhaustion and for monitoring activation times for OBAs. In fighting major fires, firefighters should leave the fire area after 30 minutes (in conjunction with the OBA timer alarm) and ensembles rotated to fresh personnel to minimize heat stress.

a) Oxygen Breathing Apparatus

Only personnel wearing an OBA shall be permitted to enter the area defined by the primary fire and smoke boundaries until the area has been certified safe for reentry without OBAs. Used OBA canisters shall be stowed in clean dry buckets for at least 30 minutes. OBA canisters shall be disposed overboard only if the cutter is underway, not within 25 miles of land. In port or within 25 miles of land used canisters shall be disposed of ashore as hazardous material.

b) Protective Clothing

Reentry into a machinery space following a fire shall be permitted only by personnel wearing a firefighters ensemble consisting of one piece coverall, gloves, anti-flash hood, helmet, OBA, and steel-toed rubber boots. **Corfam shoes are made of plastic which will melt at low temperatures and cause severe foot injuries, especially during fires. Corfam shoes are therefore prohibited on board the cutter unless authorized by the Commanding officer for a specific occasion.**

III. Firefighting Procedures for Class A, B, and C Fires

In this section general procedures are provided that apply to Class A, Class B, and Class C fires. This section is followed by compartment-specific procedures for 15 different shipboard fire scenarios section IV. Section V deals with fires in port.

A. Class A Fire Scenarios

1. Scenario

Class A fires involve ordinary combustibles such as books, paper, electrical cable insulation, stored packaging materials, combustible interior bulkheads and finishes, upholstered chairs, berthing materials including mattresses, pillows, blankets and sheets.

2. Confining the Fire

Fire and smoke boundaries shall be set on all sides (forward, aft, above and below) the affected space. Watertight bulkheads and decks are ideal boundaries, joiner bulkheads if they extend deck-to-deck can also serve as boundaries. If necessary, smoke curtains can be used to protect openings in fire and smoke boundaries if they must be open for firefighting purposes. Confining the fire also includes isolating the fire mechanically and electrically. This includes securing ventilation fans and operating machinery within the affected space. Electrical power shall be secured in the affected space with the exception of lighting.

3. Sizeup

The need to rescue trapped personnel in the affected space shall be the first consideration. Crew members shall also be immediately evacuated from adjacent spaces.

4. First Aid

If a Class A fire is discovered when it is small enough to attempt first aid the person discovering the fire should use either CO₂ or PKP portable extinguisher whichever is closer. Note PKP and CO₂ have limited effectiveness on Class A fires but may be used to control the fire while hoselines are being advanced. The use of these extinguishers on Class A materials may knockdown the flame, but the materials may quickly reignite. Use of two extinguishers in tandem is more effective than one at a time.

5. Firefighting

Class A fires should be attacked as soon as possible, to gain immediate control and to prevent or minimize the spread of fire. An attack can be direct or indirect. In a direct attack firefighters advance into the immediate fire area and apply the extinguishing agent directly onto the seat of the fire. Smoke, gases, and heat from an advanced fire make access increasingly difficult. If the fire has gained headway, a direct attack may not succeed and an indirect method should be used. During an indirect attack, firefighters can not approach a fire close enough to apply agent directly onto the fire. Water fog is discharged into the space through a cracked open door, hatch, window or some other bulkhead or overhead penetration.

a) Installed Fire Extinguishing Systems

Dry type water sprinkling systems are installed in magazines and sometimes in Cargo Holds to combat Class A fires. If installed these systems should be used if First Aid is ineffective, however dewatering operations should be started as soon as available manpower permits to prevent adverse effects on ship stability.

b) Manual Firefighting

(1) Attack Team Organization

The repair party should man two hoses, one hose team should be the attack hose and the other should act as a backup. The cutter's Watch, Quarter and Station Bill details assignments for the rest of the repair party. Hose teams and investigators should dress out in firefighters ensembles and OBAs.

(2) Direct Attack

A direct attack should employ the use of short bursts of water as opposed flowing the hose continuously. If the fire is large a sweeping motion over the fire may be effective. Short bursts permit the resulting steam to escape. As the firefighter gains control longer bursts can be used. A straight stream is required to combat deep seated fires. If directed by the scene leader a direct attack should be made by #1 hose team with a single 1.5" hose fitted with a vari-nozzle. #2 hose team should act as a backup. Water fog is preferred because it reduces the electrical shock hazard.

(3) Indirect Attack

An indirect attack has proven effective to control large fires and eventually permit a direct attack. If an indirect attack is used the hole created to insert the hose should be no larger than necessary to accommodate the hose and nozzle. The scene leader may order a direct attack simultaneously with an indirect attack. In this event the indirect attack should only continue if it does not inhibit the direct attack. Constant communications must be maintained to ensure a coordinated attack.

6. Post-fire Activities

Smoldering materials should be jettisoned, with the Commanding Officer's permission, overboard or soaked in a bucket of water on the weather deck. Conduct atmospheric testing for oxygen and toxic gas levels before entering the space without an OBA.

7. Other Actions

Dewatering operations should be started as soon as available manpower permits to prevent adverse effects on ship stability. During firefighting actions the investigator wearing an OBA shall continually inspect the fire boundaries to ensure the fire has not spread. Hot bulkheads or decks should be cooled with water from a 1.5" hose with a vari-nozzle set to apply water fog. The Emergency Generator shall be started and placed in stand-by as a potential source of electrical power. The P-250 shall be rigged and

energized as a backup source of firefighting water pressure. The electrician should secure electrical power with the exception of lighting to the affected space.

B. Class B Fire Scenarios

1. Scenario

A class B fire involves flammable liquids or gases such as fuel oil, hydraulic oil, lube oil, paint, propane or grease. One of the most hazardous and difficult fire to extinguish is a flammable liquid spray fire which typically occurs when a flammable liquid such as diesel fuel under high pressure sprays onto a hot surface such as a turbocharger or hot exhaust manifold. Major conflagrations have resulted from this scenario. This type of fire can only be effectively controlled if the pressurized source of fuel is secured. A flammable liquid spray fire shall be considered a fire out of control.

2. Confining the Fire

Fire and smoke boundaries shall be set on all sides (forward, aft, above and below) the affected space. Watertight bulkheads and decks are ideal boundaries, joiner bulkheads if they extend deck-to-deck can also serve as boundaries. If necessary, smoke curtains can be used to protect openings in fire and smoke boundaries if they must be open for firefighting purposes. Confining the fire also includes isolating the fire mechanically and electrically. This includes securing ventilation fans and operating machinery within the affected space. It is especially important to secure the source of pressurized fuel causing a spray fire.

3. Sizeup

The need to rescue trapped personnel in the affected space shall be considered. Personnel shall be immediately evacuated for a Class B fire out of control.

4. First Aid

If a class B fire (not a spray fire) is discovered when it is small enough to safely attempt first aid the person discovering the fire should use a PKP or AFFF portable fire extinguisher. If first aid is not successful or the fire grows out of control, personnel should evacuate the space and activate the installed fire extinguishing system..

5. Firefighting

Class B pool fires (less than 10 square feet) may be fought with portable PKP or AFFF extinguishers or AFFF hose reels. An oil spray fire which cannot be quickly and completely secured, should not be attacked. Experience has shown that such a fire is unapproachable. Life threatening conditions created by extreme heat, smoke and toxic gases can occur in less than 60 seconds. Under such conditions the only prudent course of action is to secure the propulsion plant, don EEBDs, and evacuate the space. Installed AFFF bilge sprinkling and CO₂ flooding systems shall be activated immediately upon evacuation of the space. AFFF bilge sprinkling shall be applied again before reentry.

a) **Installed Fire Extinguishing Systems**

AFFF bilge sprinkling systems and CO₂ total flooding systems are installed fire extinguishing systems effective against class B fires. CO₂ has limited cooling capabilities, and may not cool the fuel below its ignition temperature and is more likely than other extinguishing agents to allow reflash. AFFF on the other hand has persistence and will blanket the fuel long enough to permit cooling of the fuel below its ignition point.

b) **Manual Firefighting**

Reentry to a machinery space that has been evacuated because of fire is the most critical part of the firefighting evolution and potentially the most dangerous. The primary function of the reentry team is to attack and extinguish the fire, ensure the source of oil is secured and cool the space so ventilation may be restarted. Operate AFFF bilge sprinkling a second time for at least two minutes before reentry to prevent the possibility of an unsecured fuel source having degraded the initial foam blanket.

(1) **Attack Team Organization**

The repair party should man two hoses, one hose team should be the attack hose and the other should act as a backup. The cutter's Watch, Quarter and Station Bill details assignments for the rest of the repair party. Hose teams and investigators should dress out in firefighters ensembles and OBAs.

(2) **Direct Attack/Reentry**

Once the Class B fire has been extinguished by the CO₂ total flooding system and AFFF bilge sprinkling system reentry shall be attempted. The conditions in the affected space should be checked if possible before entry by:

- Feeling bulkheads for temperature near the desired access
- Monitoring exhaust vent discharge for smoke.
- Monitoring conditions through viewing ports or windows or closed circuit television. NFTI cannot be used for this purpose since it cannot see through glass.

To conserve AFFF saltwater hoselines can be used to cool the space after the fire is out. It should be assumed that AFFF hose reels in the space are damaged and should not be used until it can be verified that that the system has not been damaged.

If directed by the scene leader a direct attack should be made by #1 hose team with a single 1.5" hose fitted with a vari-nozzle. #2 hose team should act as a backup. Vari-nozzles should be set to apply AFFF.

(3) **Indirect Attack**

Once the source of the Class B spray fire has been secured the fire may be effectively attacked indirectly with a 1.5" hose with a vari-nozzle set to apply water fog or AFFF as directed by the scene leader inserted through a scuttle, porthole, or hole cut in

the bulkhead or overhead. This tactic has proven effective to control large fires and eventually permit a direct attack.

6. Post-fire Activities

Smoldering materials should be jettisoned, with the Commanding Officer's permission, overboard or soaked in a bucket of water on the weather deck. Conduct atmospheric testing for oxygen and toxic gas levels before entering the space without an OBA.

7. Other Actions

During firefighting actions the investigator wearing an OBA shall continually inspect the fire boundaries to ensure the fire has not spread. Hot bulkheads or decks should be cooled with water from a 1.5" hose with a vari-nozzle set to apply water fog. The Emergency Generator shall be started and placed in stand-by as a potential source of electrical power. The P-250 shall be rigged and energized as a backup source of firefighting water pressure. The electrician should secure electrical power with the exception of lighting to the affected space.

C. Class C Fire Scenarios

1. Scenario

A class C fire involves energized electronic or electrical equipment such as an electric motor, controller, switchboard, transmitter, gyrocompass, radar, console, etc. There is also a significant possibility of a class A fire in ordinary combustibles that is ignited by the electrical fire.

2. Confining the Fire

Fire and smoke boundaries shall be set on all sides (forward, aft, above and below) the affected space. Watertight bulkheads and decks are ideal boundaries, joiner bulkheads if they extend deck-to-deck can also serve as boundaries. If necessary, smoke curtains can be used to protect openings in fire and smoke boundaries if they must be open for firefighting purposes. Confining the fire also includes isolating the fire mechanically and electrically. This includes securing ventilation fans and operating machinery within the affected space. Electrical power shall be secured in the affected space with the exception of lighting.

3. Sizeup

The need to rescue trapped personnel in the affected space shall be considered. Class C fires are usually extinguished when electrical power is secured, however a class A fire may be burning in conjunction with the equipment that was the cause of the class C fire. Therefore firefighters shall be prepared to extinguish a Class A as well as a Class C fire.

4. First Aid

If the fire is discovered when it is small enough to attempt first aid the person discovering the fire should use a CO₂ portable fire extinguisher on class C fires and either CO₂ or PKP portable extinguisher on Class A fires. Note PKP and CO₂ have limited effectiveness on Class A fires but may be used while hoselines are being advanced.

5. Firefighting

Class C fires should be attacked by securing the electrical power to the affected equipment first and then attacking the remaining class A fire directly (charged capacitors in electronic equipment may retain a significant electrical charge after power is secured).

a) Installed Fire Extinguishing Systems

CO₂ flooding systems are frequently installed in main propulsion motors. In the event of a Class C fire in a compartment, main propulsion motor, or other similarly protected equipment, the preferred method for extinguishing the fire is to evacuate the space, deenergize the equipment, and activate the installed fire extinguishing system. CO₂ has limited cooling capabilities, and may not cool the fuel below its ignition temperature and is more likely than other extinguishing agents to allow reflash. Therefore, the firefighter must remember to standby with additional backup extinguishers, the temperature of the burning substance and its surroundings must be lowered below its ignition temperature if the fire is to remain extinguished.

b) Manual Firefighting

(1) Attack Team Organization

The repair party should man two hoses, one hose team should be the attack hose and the other should act as a backup. The cutter's Watch, Quarter and Station Bill details assignments for the rest of the repair party. Hose teams and investigators should dress out in firefighters ensembles and OBAs.

(2) Direct Attack

Once the Class C fire has been extinguished by deenergizing the equipment the remaining Class A fire may be effectively attacked directly depending on the size of the fire. If directed by the scene leader a direct attack should be made by #1 hose team with a single 1.5" hose fitted with a vari-nozzle. #2 hose team should act as a backup. Vari-nozzles should be set to apply water fog, although a staright stream may be required for deep seated fires. Water fog is preferred because it reduces the electrical shock hazard.

(3) Indirect Attack

Once the Class C fire has been extinguished by deenergizing the equipment the remaining Class A fire may be effectively attacked indirectly with a 1.5" hose with a vari-nozzle set to apply water fog inserted through a scuttle, porthole, or hole cut in the bulkhead or overhead. This tactic has proven effective to control large fires and eventually permit a direct attack.

6. Post-fire Activities

Smoldering materials should be jettisoned, with the Commanding Officer's permission, overboard or soaked in a bucket of water on the weather deck. Conduct atmospheric testing for oxygen and toxic gas levels before entering the space without an OBA.

7. Other Actions

During firefighting actions the investigator wearing an OBA shall continually inspect the fire boundaries to ensure the fire has not spread. Hot bulkheads or decks should be cooled with water from a 1.5" hose with a vari-nozzle set to apply water fog. The Emergency Generator shall be started and placed in stand-by as a potential source of electrical power. The P-250 shall be rigged and energized as a backup source of firefighting water pressure. The electrician should secure electrical power with the exception of lighting to the affected space.

IV. Firefighting Procedures for Specific Compartments

The general procedures for firefighting are given in Section III for each class of fire. The information provided in this section for specific compartments augments the procedures described in Section III.

A. Pilothouse (03-56-0-C)

Scenario: Class C fire in energized electronic or electrical equipment such as the radar. There is also a significant possibility of a class A fire in ordinary combustibles such as charts and logbooks in the chart area.

Fire Boundaries: The superstructure on the 03 Deck forward and aft, port and starboard, and the 02 Deck below.

Sizeup: Need to rescue personnel: Minimal.

Firefighting:

- Installed Fire Extinguishing System: None
- Indirect attack may be feasible through a window in the Pilothouse after deenergizing the affected electrical equipment in the Pilothouse.
- Direct attack through the windward weathertight door on the port or starboard side of the Pilothouse from the 03 Weather Deck, with a 1.5" fire hose equipped with a vari nozzle set to apply water fog, after deenergizing the affected electrical equipment in the Pilothouse.

B. Commanding Officer's Cabin (02-57-0-L)

Scenario: Class A fire in overstuffed furniture.

Fire Boundaries: The superstructure on the 02 Deck forward and aft, port and starboard, the 03 Deck above and the 01 deck below.

Sizeup: Need to rescue personnel: Minimal, however personnel may be trapped in C.O. Stateroom (02-57-1-L) where the only means of egress is through this space.

Firefighting:

- Installed Fire Extinguishing System: None
- Indirect attack is not feasible
- Direct attack through the joiner door in Passageway (02-57-0-L) with a 1.5" fire hose equipped with a vari nozzle set to apply water fog.

C. Fan Room (02-73-0-Q)

Scenario: Class C fire in electrical fan motor accompanied by a Class A fire in the insulation on the ventilation ductwork.

Fire Boundaries: The superstructure on the 02 Deck forward and aft, port and starboard, the 03 Deck above and the 01 deck below.

Sizeup: Need to rescue personnel: Minimal.

Firefighting:

- Installed Fire Extinguishing System: None.
- Indirect attack through watertight door 02-77-2 from the 02 Weather Deck with a 1.5" fire hose equipped with a vari nozzle set to apply water fog after deenergizing affected electrical equipment in the Fan Room (02-73-0-Q). The joiner door in Passageway (02-89-2-Q) should be kept secured.
- Direct attack through watertight door 02-77-2 from the 02 Weather Deck with a 1.5" fire hose equipped with a vari nozzle set to apply water fog after deenergizing affected electrical equipment in the Fan Room (02-73-0-Q). The joiner door in Passageway (02-89-2-Q) should be kept secured

D. Emergency Generator Room (01-78-3-E)

Scenario: Class B fire due to ruptured lube oil or fuel oil line on the emergency generator diesel engine.

Fire Boundaries: The superstructure on the 01 Deck starboard, bulkhead 78 forward, bulkhead 86 aft, the MMR Uptake port, the 02 Deck above and the Main Deck below.

Sizeup: Need to rescue personnel: Minimal in the Emergency Generator Room, however any personnel in the Medical Treatment Room (01-74-1-L) forward and Crews Stateroom (01-86-1-L) aft should be immediately evacuated.

Firefighting:

- Installed Fire Extinguishing System: CO₂ total flooding system should be energized in the event of a Class B spray fire after all personnel have been evacuated and the pressurized source of fuel has been secured.

- Indirect attack may be feasible through the shutters on the starboard side of the 01 Deck superstructure with a 1.5" fire hose equipped with a vari nozzle set to apply AFFF.

- Direct attack (and reentry) through the joiner door in Passageway (01-79-0-L) with a 1.5" fire hose equipped with a vari nozzle set to apply AFFF.

E. Main Machinery Room (4-66-0-E)

Scenario: Class B fire due to ruptured lube oil or fuel oil line on one of the main propulsion diesel engines or one of the ship service generator diesel engines.

Fire Boundaries: Primary: bulkhead 66 forward, bulkhead 82 aft, Main Deck above and Hull below. Secondary: bulkhead 57 forward, bulkhead 92 aft, Main Deck above and Hull below.

Sizeup: Need to rescue personnel: Watchstanders or day workers may be trapped in the Main Machinery Room. The Engineering Control Center (2-89-1-C) is occupied continuously underway, however if evacuation is required personnel may escape through the escape scuttle to the Crews Mess (1-66-0-L).

Firefighting:

- Installed Fire Extinguishing System: Both AFFF bilge sprinkling system and CO₂ total flooding system should be activated in the event of a Class B spray fire after all personnel have been evacuated and the pressurized source of fuel has been secured.

- Indirect attack may be feasible through the watertight scuttle in the watertight hatch in Companionway (1-66-2-L) with a 1.5" fire hose equipped with a vari nozzle set to apply AFFF.

- Direct attack (and reentry) through the watertight hatch in Companionway (1-66-2-L) with a 1.5" fire hose equipped with a vari nozzle set to apply AFFF.

F. Cargo Hold (2-30-0-AA)

Scenario: Class A fire in ordinary combustibles.

Fire Boundaries: Watertight bulkheads 30 forward, and 38 aft, Buoy Deck above and fuel tanks below.

Sizeup: Need to rescue personnel: Minimal.

Firefighting:

- Installed Fire Extinguishing System: Dry type water sprinkling system should be activated for Class A fires in the Cargo Hold.

- Indirect attack may be feasible through watertight door in Passageway (2-21-0-L) or through joiner door in Passageway (2-36-1-L) with a 1.5" fire hose equipped with a vari nozzle set to the water fog position.

- Direct attack through watertight door in Passageway (2-21-0-L) or through joiner door in Passageway (2-36-1-L) with a 1.5" fire hose equipped with a vari nozzle set to the water fog position.

G. Electronics IC & Gyro Room (03-66-01-C)

Scenario: Class C fire in energized electronic or electrical equipment such as the gyrocompass. There is also a significant possibility of a class A fire in ordinary combustibles such as publications or paper stowed in this space.

Fire Boundaries: The superstructure on the 03 Deck forward, aft, port, and starboard, and the 02 Deck below

Sizeup: Need to rescue personnel: Minimal.

Firefighting:

- Installed Fire Extinguishing System: None.
- Indirect attack is not feasible.
- Direct attack through the joiner door from the Pilothouse (03-56-0-C), with a 1.5" fire hose equipped with a vari nozzle set to apply water fog after deenergizing affected electrical equipment in the Electronics IC & Gyro Room.

H. Auxiliary Machinery Room (4-82-0-E)

Scenario: Class B fire due to ruptured fuel oil line to the SORS boiler.

Fire Boundaries: Primary: bulkhead 82 forward, bulkhead 92 aft, Main Deck above and Hull below. Secondary: bulkhead 66 forward, bulkhead 102 aft, Main Deck above and Hull below.

Sizeup: Need to rescue personnel: Watchstanders or day workers may be trapped in the Auxiliary Machinery Room.

Firefighting:

- Installed Fire Extinguishing System: Both AFFF bilge sprinkling system and CO₂ total flooding system should be energized in the event of a Class B spray fire after all personnel have been evacuated and the pressurized source of fuel has been secured.
- Indirect attack may be feasible through the watertight scuttle in the watertight hatch in Companionway (1-84-2-L) with a 1.5" fire hose equipped with a vari nozzle set to apply AFFF.
- Direct attack (and reentry) through the watertight hatch in Companionway (1-84-2-L) with a 1.5" fire hose equipped with a vari nozzle set to apply AFFF.

I. Stern Thruster Machinery Room (4-92-0-E)

Scenario: Class C fire in thruster motor or Class B fire due to ruptured hydraulic line in one of the hydraulic power units.

Fire Boundaries: Primary: watertight bulkheads 92 forward and 102 aft, Main Deck above and Hull below. Secondary: watertight bulkheads 82 forward and stern aft, Main Deck above and Hull below.

Sizeup: Need to rescue personnel: Minimal.

Firefighting:

- Installed Fire Extinguishing System: AFFF bilge sprinkling system should be activated in the event of a Class B fire.
- Indirect attack may be feasible through the watertight scuttle in the watertight hatch in Passageway (1-92-0-L) with a 1.5" fire hose equipped with a vari nozzle set to apply water fog after deenergizing affected electrical equipment in the Stern Thruster Room.
- Direct attack on a Class A fire should be attempted through the watertight hatch in Passageway (1-92-0-L) with a 1.5" fire hose equipped with a vari nozzle set to apply water fog after deenergizing affected electrical equipment in the Stern Thruster Room. Direct attack on a Class B fire should be attempted through the watertight hatch in Passageway (1-92-0-L) with a 1.5" fire hose equipped with a vari nozzle set to apply AFFF.

J. Bow Thruster Machinery Room (4-12-0-E)

Scenario: Class C fire in thruster motor or Class B fire due to ruptured hydraulic line in one of the hydraulic power units.

Fire Boundaries: Primary: watertight bulkheads 12 forward and 21 aft, Main Deck above and Hull below. Secondary: watertight bulkheads 6 forward and 30 aft, Main Deck above and Hull below.

Sizeup: Need to rescue personnel: Minimal.

Firefighting:

- Installed Fire Extinguishing System: AFFF bilge sprinkling system should be activated in the event of a Class B fire.
- Indirect attack may be feasible through the watertight scuttle in the watertight hatch in Companionway (1-15-1-L) with a 1.5" fire hose equipped with a vari nozzle set to apply water fog after deenergizing affected electrical equipment in the Bow Thruster Room.
- Direct attack on a Class A fire should be attempted through the joiner door in Companionway (1-15-1-L) with a 1.5" fire hose equipped with a vari nozzle set to apply water fog after deenergizing affected electrical equipment in the Bow Thruster Room. Direct attack on a Class B fire should be attempted through the joiner door in Companionway (1-15-1-L) with a 1.5" fire hose equipped with a vari nozzle set to apply AFFF.

K. SOR Machinery Room (2-49-0-E)

Scenario: Class B fire due to ruptured oil line to the SOR machinery.

Fire Boundaries: Primary: bulkhead 48 forward, bulkhead 57 aft, Buoy Deck above and Hull below. Secondary: bulkhead 38 forward, bulkhead 66 aft, Buoy Deck above and Hull below.

Sizeup: Need to rescue personnel: Minimal.

Firefighting:

- Installed Fire Extinguishing System: AFFF bilge sprinkling system should be energized in the event of a Class B spray fire after all personnel have been evacuated and the pressurized source of fuel has been secured.
- Indirect attack may be feasible through the joiner door in the Vestibule (2-53-1-L) with a 1.5" fire hose equipped with a vari nozzle set to apply AFFF.
- Direct attack through the joiner door in the Vestibule (2-53-1-L) with a 1.5" fire hose equipped with a vari nozzle set to apply AFFF.

L. Steering Gear Room (1-102-0-E)

Scenario: Class B fire due to ruptured hydraulic oil line to the steering gear machinery.

Fire Boundaries: Bulkhead 102 forward, Hull starboard and aft, Longitudinal Bulkhead to port of centerline, 01 Deck above and Void below

Sizeup: Need to rescue personnel: Minimal in the Steering Gear Room, however crew members in Crews Stateroom (1-96-0-L), and Laundry (1-105-2-Q) should be immediately evacuated.

Firefighting:

- Installed Fire Extinguishing System: AFFF bilge sprinkling system should be energized in the event of a Class B spray fire after all personnel have been evacuated and the pressurized source of fuel has been secured.
- Indirect attack may be feasible through the watertight door in the Deck Gear Storeroom (1-102-2-A) with a 1.5" fire hose equipped with a vari nozzle set to apply AFFF.
- Direct attack through the watertight door in the Deck Gear Storeroom (1-102-2-A) with a 1.5" fire hose equipped with a vari nozzle set to apply AFFF.

M. Galley (1-57-1-Q)

Scenario: Class B grease fire in the Galley stove.

Fire Boundaries: Bulkhead 57 forward, bulkhead 66 aft, centerline bulkhead port, Hull starboard, 01 Deck above and 2nd Deck below.

Sizeup: Need to rescue personnel: Personnel are likely to be working in the Galley, in addition crew members in the Mess Deck (1-66-0-L), Galley Annex (1-66-1-Q), and Scullery (1-66-3-Q) should be immediately evacuated.

Firefighting:

- Installed Fire Extinguishing System: Aqueous potassium carbonate system should be energized in the event of a Class B grease fire in the Galley Stove.
- Indirect attack Class B fires through the watertight door in the Galley Annex (1-66-1-Q) with a 1.5" fire hose equipped with a vari nozzle set to apply AFFF. Indirect attack Class A fires through the watertight door in the Galley Annex (1-66-1-Q) with a 1.5" fire hose equipped with a vari nozzle set to apply water fog. is not feasible
- Direct attack Class B fires through the watertight door in the Galley Annex (1-66-1-Q) with a 1.5" fire hose equipped with a vari nozzle set to apply AFFF. Direct attack Class A fires through the watertight door in the Galley Annex (1-66-1-Q) with a 1.5" fire hose equipped with a vari nozzle set to apply water fog.

N. Laundry (1-105-2-Q)

Scenario: Class A fire in clothing.

Fire Boundaries: Bulkhead 105 forward, stern port and aft, centerline bulkhead starboard, 01 Deck above and 2nd Deck below.

Sizeup: Need to rescue personnel: Minimal.

Firefighting:

- Installed Fire Extinguishing System: None.
- Indirect attack may be feasible through the watertight door in the Deck Gear Storeroom (1-102-2-A) with a 1.5" fire hose equipped with a vari nozzle set to apply water fog.
- Direct attack through the watertight door in the Deck Gear Storeroom (1-102-2-A) with a 1.5" fire hose equipped with a vari nozzle set to apply water fog.

O. Flammable Liquid Storeroom (1-6-2-A)

Scenario: Class B fire in paint or other flammable liquids.

Fire Boundaries: Bulkhead 6 forward, bulkhead 12 aft, centerline bulkhead port, Hull starboard, Chain Locker below and 01 Deck above.

Sizeup: Need to rescue personnel: Minimal.

Firefighting:

- Installed Fire Extinguishing System: CO₂ total flooding system should be energized in the event of a Class B fire after all personnel have been evacuated.
- Indirect attack not feasible.

- Direct attack (and reentry) through the joiner door in Passageway (1-12-1-L) with a 1.5" fire hose equipped with a vari nozzle set to apply AFFF.

V. In Port Fires

A. Scenario

The most likely fire in port is a class A fire in one of the Berthing Areas in bedding materials. A class B fire in the galley is also a likely fire in port.

B. Confining the Fire

The fire boundaries established depend on the involved compartment.

C. Sizeup

Due to the likelihood of sleeping crewmembers, there is a strong possibility that personnel may need to be rescued. All off-duty crew members on board must be accounted for and may be required to assist in extinguishing the fire. The local fire department should be notified of every in port fire and assistance requested if needed. Therefore local fire departments should be periodically invited to the ship for familiarity tours.

D. First Aid

If the fire is discovered when it is small enough to attempt first aid the person discovering the fire should use a portable extinguisher suitable for the Class fire as described in Section III above.

E. Indirect Attack

An indirect or direct attack can only be attempted in the event the full in port duty section is on board to properly man a repair party, otherwise additional help will be required. This help can come from another Coast Guard Cutter, the Group or Station where the Cutter is berthed, or from the local fire department. An indirect attack may be directed by the scene leader as described in section III above for the particular class of fire involved.

F. Direct Attack

A direct attack may be attempted if the scene leader directs in accordance with the procedures described in section III above for the particular class of fire involved.

G. Post-fire Activities

Smoldering materials should be jettisoned, with the Commanding Officer's permission, overboard or soaked in a bucket of water on the weather deck. Conduct atmospheric testing for oxygen and toxic gas levels before entering the space without an OBA.

H. Other Actions

Dewatering operations should be commenced as soon as available manpower permits in the event saltwater hoselines are used. During firefighting actions the investigator wearing an OBA shall continually inspect the fire boundaries to ensure the fire has not spread. The emergency generator shall be started and placed in standby as a backup source of electrical power. The P-250 shall be rigged as a backup source of firefighting water if the scene leader so directs. The electrician should secure electrical power with the exception of lighting to the affected space.