

Sum
①

NAVY DEPARTMENT
THE DAVID W. TAYLOR MODEL BASIN
WASHINGTON 7, D.C.

DISTRIBUTION STATEMENT A
Approved for public release
Distribution Unlimited

DTIC
ELECTE
NOV 12 1991
S C D

STRESS DISTRIBUTION IN THE FLANGES
OF CURVED T AND I BEAMS

by

Hans Bleich, Vienna

19970117 008

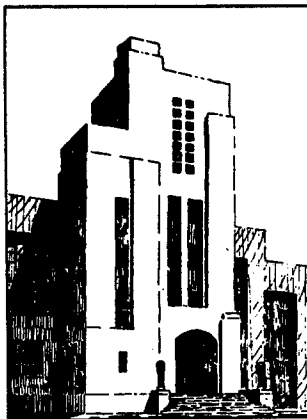

91-15349

January 1950

NSRDC LIBRARY

Translation 228

APPROVED FOR PUBLIC RELEASE: DISTRIBUTION UNLIMITED

91 1108 081

DTIC QUALITY INSPECTED 1

INITIAL DISTRIBUTION

Copies

- 7 Chief of the Bureau of Ships, Project Records (Code 362)
for distribution:
 - 1 Technical Assistant to Chief of the Bureau (Code 106)
 - 1 Research-Structures (Code 372)
 - 5 Project Records (Code 362)

- 2 Chief of Naval Operations, Op-322F2



Accession For	
NEIS GRAAI	<input checked="" type="checkbox"/>
DTIC TAB	<input type="checkbox"/>
Unannounced	<input type="checkbox"/>
Justification	
By _____	
Distribution/	
Availability Codes	
Dist	Avail and/or Special
A-1	

UNANNOUNCED
NSRDC LIBRARY

STRESS DISTRIBUTION IN THE FLANGES OF CURVED T AND I BEAMS

(DIE SPANNUNGSVERTEILUNG IN DEN GURTUNGEN GEKRÜMMTER
STÄBE MIT T- UND I- FÖRMIGEM QUERSCHNITT)

by

Hans Bleich, Vienna

(Der Stahlbau, Beilage zur Zeitschrift "Die Bau-
technik," Vol 6, No. 1, 6 January 1933, pp. 3-6)

Translated by E.N. Labouvie, Ph.D.

January 1950

Translation 228

NSRDC LIBRARY

UO22-215 COPY 2

STRESS DISTRIBUTION IN THE FLANGES OF CURVED T AND I BEAMS

Extreme fiber stresses in curved frames (Rahmenecken) are determined either according to Navier--as in the case of the straight beam--or better yet, according to the theory of the curved beam by Grashof and Resal. The latter appraises the extreme fiber stress of the concave side much more correctly than does the Navier method of calculation. This calculation of the curved beam is designed, however, for solid (cross) sections and has to be modified when applied to the T- and I-beam cross sections used in steel construction, since one postulate of this theory, namely the invariability of the shape of the cross section, is no longer fulfilled in these beam forms.

If one considers a curved beam of rectangular cross section (as an example of a solid (cross) section), one observes that stresses running in transverse direction with respect to the longitudinal fibers, in addition to the longitudinal stresses, are necessary in order to maintain equilibrium. We shall designate these stresses as transverse stresses. In the moment application represented in Figure 1 the transverse forces act from both surfaces toward the center and seek to compress the beam. The resulting deformation is so slight that it does not influence the longitudinal stresses materially. The situation is quite different, however, in the case of thin-walled T and I cross sections. The projecting parts of the cross sections appear to be subjected to bending stress due to the transverse forces (Figure 2) and therefore they deform in the manner indicated. Since the transverse displacements of the flange points are of the same order of magnitude as the flange elongations resulting from the bending of the beam, they influence the distribution of longitudinal stresses over the cross section a great deal. This is the same phenomenon as the one observed in the case of the thin-walled curved tube where the measured angles due to bending are several times as large as the angles which are to be expected according to usual theory.*

The following investigations refer to T or I beams which are symmetric with respect to the plane of the web, the load plane of which coincides with the web plane. Let the flange of the beam under consideration have the radius of curvature r , and let the flange thickness d be small compared with the other cross-sectional

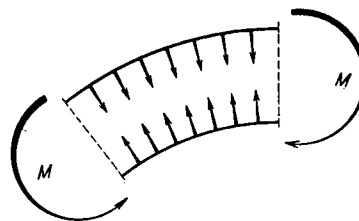

Figure 1

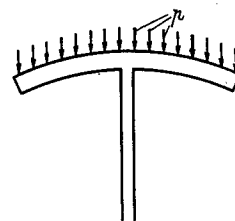

Figure 2

*v. Kármán: The Deformation of thin-walled tubes etc. Z. d. VdI 1911, page 1889 (Journal of the Association of German Engineers etc.)

measurements; then the longitudinal stresses σ and the elongations ϵ will differ slightly at the upper and lower edge of the flange, so that we may carry on our calculations with the mean values $\bar{\sigma}$ and $\bar{\epsilon}$. At a point at a distance x (Figure 3) from the plane of the web the stresses and elongations are $\bar{\sigma}_x$ and $\bar{\epsilon}_x$. The deflection of the flange at this point is y_x . If one takes out a flange piece of the length ds , the cross-sectional planes include an angle $d\phi$.* If the beam is subjected to a load, this angle increases by $\Delta d\phi$. As a result, a flange fiber located directly above the web elongates by Δds (Figure 4), so that the elongation per unit length there amounts to

$$\bar{\epsilon}_m = \frac{\Delta ds}{ds}$$

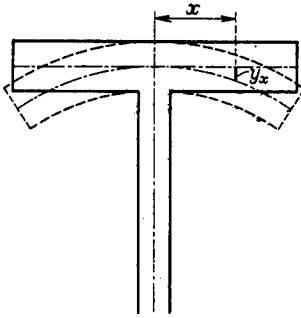

Figure 3

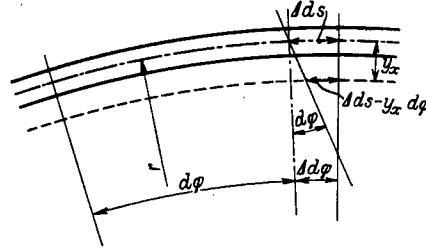

Figure 4

A strip located at a distance x from the web plane has deflected by y_x , and its center axis has assumed the position which is indicated in dotted lines in Figure 4. If magnitudes of a higher infinitesimal order are neglected this fiber has elongated by $\Delta ds - y_x d\phi$; its elongation per unit length therefore is

$$\bar{\epsilon}_x = \frac{\Delta ds}{ds} - y_x \cdot \frac{d\phi}{ds} = \frac{\Delta ds}{ds} - \frac{y_x}{r}$$

The stress directly above the web is

$$\bar{\sigma}_m = E \bar{\epsilon}_m = E \cdot \frac{\Delta ds}{ds} \quad [1]$$

and the stress at the distance x from the plane of the web is

$$\bar{\sigma}_x = E \left(\frac{\Delta ds}{ds} - \frac{y_x}{r} \right) = \bar{\sigma}_m - E \cdot \frac{y_x}{r} \quad [1']$$

While the longitudinal stress in the center and at the surface of the flange is kept constant, if one disregards the cross-sectional deformation, Equation [1'] yields a decrease of the longitudinal stresses σ_x as y_x increases, i.e. as the distance from the web plane increases.

To complete the task before us, it is necessary to set up an addi-

* ϕ and φ (Figure 4) are the same.

tional relationship between σ_x and y_x other than that in Equation [1]. For this purpose, we shall first calculate the magnitude of the transverse forces in the beam. Let the force S flow in a fiber with the radius of curvature r . From Figure 5 one obtains the transverse force in the length ds ,

$$A = S \cdot d\varphi$$

The transverse force per unit of length is therefore

$$a = S \cdot \frac{d\varphi}{ds} = \frac{S}{r}$$

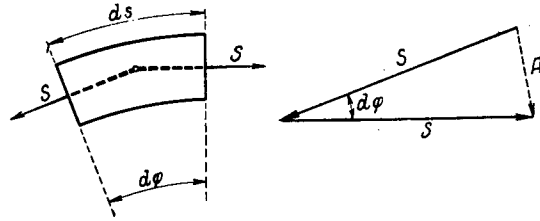

Figure 5

A force $S = \bar{\sigma}_x d$ flows in a flange strip of unit width (Figure 6); therefore the flange is subjected to a transverse force

$$p = \frac{\sigma_x d}{r}$$

per unit of area.

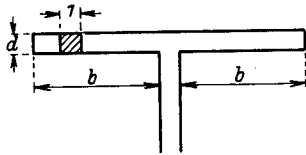

Figure 6

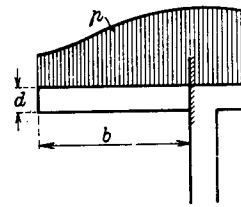

Figure 7

If one takes out a strip of unit width, measured in the longitudinal direction of the beam, the flange of the beam can (for reasons of symmetry) be considered as a cantilever rigidly fixed at the web, which is subjected to the load

$$p = \frac{\sigma_x d}{r} = \frac{d}{r} \left(\sigma_m - E \cdot \frac{y_x}{r} \right)$$

The differential equation of the deflection curve of this beam reads

$$EJ \cdot \frac{d^4 y_x}{dx^4} = p$$

If one substitutes for $J = \frac{d^3}{12}$ and for p the value obtained above, one obtains for y_x the differential equation

$$\frac{d^4 y_x}{dx^4} + \frac{12}{r^2 d^2} \cdot y_x = \frac{1}{E} \cdot \frac{12 \bar{\sigma}_m}{r d^2} \quad [2]$$

If one now measures x from the fixing point, the boundary conditions of this differential equation are

$$\left. \begin{array}{l} \text{for } x = 0 \quad y = 0, \quad \frac{dy}{dx} = 0, \\ \text{for } x = b \quad \frac{d^2y}{dx^2} = 0, \quad \frac{d^3y}{dx^3} = 0 \end{array} \right\} \quad [2']$$

The general solution of the differential equation [2] has the form

$$y_x = \frac{r\bar{\sigma}_m}{E} + C_1 \cdot \sin \alpha x \cdot \sinh \alpha x + C_2 \cdot \sin \alpha x \cdot \cosh \alpha x \\ + C_3 \cdot \cos \alpha x \cdot \sinh \alpha x + C_4 \cdot \cos \alpha x \cdot \cosh \alpha x,$$

wherein $\alpha^4 = \frac{3}{r^2 d^2}$. The solution adapted to the boundary conditions [2'] is

$$y_x = \frac{\bar{\sigma}_m r}{E} \left(1 - \frac{1}{2 + \cos 2\alpha b + \cosh 2\alpha b} \right. \\ \cdot [2 \cdot \cosh \alpha b \cdot \cos \alpha x \cdot \cosh \alpha(b-x) \\ + 2 \cdot \cos \alpha b \cdot \cos \alpha(b-x) \cdot \cosh \alpha x \\ \left. + \sin \alpha x \cdot \sinh \alpha(2b-x) - \sin \alpha(2b-x) \cdot \sinh \alpha x] \right). \quad [3]$$

From Equations [1'] and [3] it follows that

$$\bar{\sigma}_x = \frac{\bar{\sigma}_m}{2 + \cos 2\alpha b + \cosh 2\alpha b} [2 \cdot \cosh \alpha b \cdot \cos \alpha x \cdot \cosh \alpha(b-x) \\ + 2 \cdot \cos \alpha b \cdot \cos \alpha(b-x) \cdot \cosh \alpha x \\ + \sin \alpha x \cdot \sinh \alpha(2b-x) - \sin \alpha(2b-x) \cdot \sinh \alpha x] \quad [3']$$

In Figure 8 the stress distribution in the flange has been indicated for two special cases. The stress has its maximum value σ_m in the center, above the web, and it decreases toward the edges. From the second representation in Figure 8, one gathers that we might even meet with a case where the stress at the edge has a different sign from the one above the web.

For the purpose of further calculation, we shall now assume the flange of the width b to be replaced by a narrower flange in which, however, the stress σ_m prevails everywhere and the width b' is chosen in such a manner that the total force in the beam remains unchanged. The equilibrium of the internal forces in the beam is not disturbed thereby, since the resulting longitudinal force, according to the definition of the width b' , remains unchanged and also the magnitude of the moment is preserved, because the lever arm of the forces in the beam has remained constant. Hence, for the "effective width" b , the following holds true:

$$b' = \frac{1}{\sigma_m} \int_0^b \sigma_x dx$$

After carrying out the integration, one obtains the simple expression

$$\nu = \frac{b^3}{b} = \frac{1}{\alpha b} \cdot \frac{\sin 2\alpha b + \sinh 2\alpha b}{2 + \cos 2\alpha b + \cosh 2\alpha b} \quad [4]$$

The practical application is as follows: First, one determines the effective widths of the upper and lower flange and thus one obtains an ideal cross section with reduced flange widths. The determination of the stresses σ in the curved beam is based on this ideal cross section. For these stresses the following holds true as is generally known*

$$\sigma = \frac{N}{F} - \frac{M}{RF} - \frac{Mv}{Z} \cdot \frac{R}{R+v} \quad [5]$$

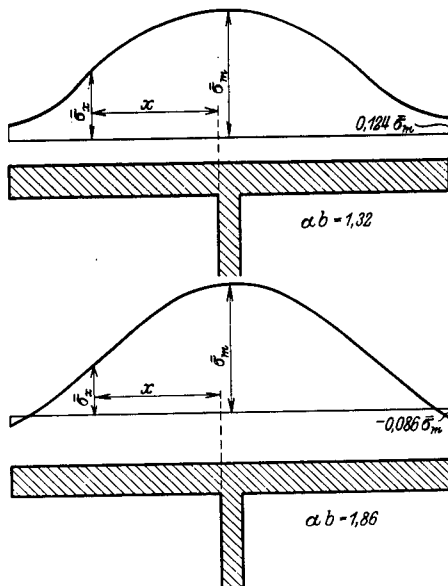

Figure 8

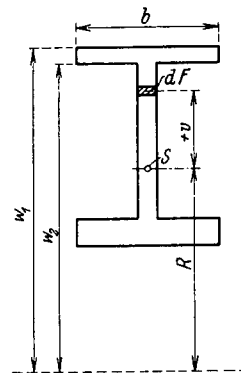

Figure 9

Herein, N is the longitudinal force and M is the moment referred to the center of gravity of the cross section (M is positive if there is tension on the inner surface, R is the radius of curvature of the gravity axis (Figure 9), v is the distance from the center of gravity of the cross section, Z the expression

$$Z = \int_F v^2 \frac{R}{R+v} \cdot dF \quad [6]$$

For the cross sections composed of rectangles which occur in actual practice, one can find Z by adding and subtracting the parts of the indi-

*Cf. H. Müller-Breslau: "Die Graphische Statik der Baukonstruktionen" (Graphical Statics of Building Constructions), Vol. II, Section 2, 2nd edition, page 368.

vidual rectangles. For such cross sections, the following relationship holds true:

$$Z = R^3 \sum \pm b \cdot \log \text{nat} \frac{w_1}{w_2} - FR^2 \quad [6']$$

In this formula, F is the total area of the cross section, w_1 and w_2 are the distances of the upper and lower sides of the rectangle from the center of curvature, b is the width of the rectangle. In Figure 9, b and w are indicated for the upper flange.

If R is greater than twice the height of the beam, one can, with very good approximation, substitute the moment of inertia J for Z so that

$$\sigma = \frac{N}{F} - \frac{M}{RF} - \frac{Mv}{J} \cdot \frac{R}{R+v} \quad [5']$$

The extreme fiber stresses calculated in the manner indicated are the maximum values of the stress which actually occur. They occur directly above the web. In the direction away from the web the extreme fiber stresses σ_x decrease, and, indeed, according to the same law as the $\bar{\sigma}_x$. The numerical determination of the $\bar{\sigma}_x$ from the rather complicated Equation [3'] is no longer necessary, either for the determination of the maximum extreme fiber stress or elsewhere.

There still remains the calculation of the magnitude of the secondary bending stresses in the projecting parts. The moment per unit of length of the flange is at the point of fixation

$$M' = \frac{d}{r} \int_0^b x \bar{\sigma}_x dx$$

If one carries through the integration and if it is considered that the resisting moment of the flange is $W = \frac{d^2}{6}$, the bending stress σ' results in the form

$$\sigma' = \mu \bar{\sigma}_m = \sqrt{3} \cdot \frac{\cosh 2\alpha b - \cos 2\alpha b}{2 + \cosh 2\alpha b - \cos 2\alpha b} \cdot \sigma_m \quad [7]$$

Since σ' depends on $\bar{\sigma}_m$, we must, in determining the stress in the ideal cross section, also calculate the stress $\bar{\sigma}_m$, i.e. the stress at the distance $\frac{d}{2}$ from the extreme fiber, in addition to the extreme fiber stress.

In determining the longitudinal shear stresses and transverse stresses transmitted by the collar rivets (Halsnieten) of riveted beams, the ideal cross section should again be used, as the decrease of the longitudinal stresses in the projecting parts of the cross section is taken into account in this manner. From Equation [5] the value of the longitudinal shear stress per unit

of length can be approximated as

$$t = Q \left[\frac{F_1}{RF} + \frac{S_1 R}{Zr} \right] \quad [8]$$

R, F, and Z have the same significance as in Equation [5]; F_1 and S_1 represent area and static moment of the flange of the ideal cross section referred to its gravity axis, Q is the shearing force and r the radius of curvature of the flange axis. The transverse force per unit of length with the same designations is

$$a = \left(\frac{N}{F} - \frac{M}{RF} \right) \frac{F_1}{r} - M \cdot \frac{S_1 R}{Zr^2} \quad [9]$$

The composition of these two forces results in the total force transmitted by the collar rivets.

In the case of beams with face plates the upper rivets (Kopfniete), besides being subjected to the longitudinal shear stress which is calculated according to Equation [8], are subjected to additional stresses due to the secondary bending of the flanges. These rivets have to take the total shear stress in the horizontal flange joints. If the calculations are based on the most unfavorable assumption that the joint lies in the center, then the shear stress per unit of length is

$$t' = \int \frac{3}{2} \cdot \frac{Q}{d} \cdot dx = \frac{3}{2d} \cdot M'$$

wherein M' is the bending moment determined above. Finally there results

$$t' = \mu \cdot \frac{d}{4} \cdot \sigma_m \quad [10]$$

μ is the coefficient indicated in Equation [7].

For the practical calculation, the values of r and μ are represented as functions of $\frac{b^2}{rd}$ in the following table. Herein, d is the flange thickness, b the width of the projecting flange, r the radius of curvature of the flange.

Table for Calculating the Effective Widths $b' = \nu b$
and the Additional Bending Stress $\sigma' = \mu \sigma_m$

$\frac{b^2}{rd}$	0	0.1	0.2	0.3	0.4	0.5	0.6	0.7	0.8	0.9
ν	1.000	0.994	0.977	0.950	0.917	0.878	0.838	0.800	0.762	0.726
μ	0	0.297	0.580	0.836	1.056	1.238	1.382	1.495	1.577	1.636
$\frac{b^2}{rd}$	1.0	1.1	1.2	1.3	1.4	1.5	2.0	3.0	4.0	5.0
ν	0.693	0.663	0.636	0.611	0.589	0.569	0.495	0.414	0.367	0.334
μ	1.677	1.703	1.721	1.728	1.732	1.732	1.707	1.671	1.680	1.700

Let us point out once more that b represents the width of only the projecting part of the flange; we are justified in deducting even a part of the fillet (see example in Figure 10). Likewise, the reduction by ν , refers only to these projecting parts so that, for example, the angle legs* adjoining the web remain fully effective. One difficulty presents itself when the rivet deductions are considered. The simplest procedure is to reduce also the rivet deductions in the projecting parts by ν .

Let us point out that in the foregoing derivation an essential factor was neglected. In setting up Equation [1] and [1'] the calculation of the elongations $\bar{\epsilon}_m$ and $\bar{\epsilon}_x$ was performed in such a manner that a linear condition of stress was assumed to be present although, in addition to the stress σ_x , there were still the stresses σ' perpendicular to σ_x . If this had been taken into account, the derivation (as well as the final result) would have become considerably more complicated as in that case the distribution of the stresses σ_x over the flange thickness d could no longer have been considered uniform. Furthermore, in setting up Equation [2] it was not taken into account that -- because of the impeded transverse elongation -- $\frac{m^2}{m^2 - 1} J$ should correctly be substituted for J , wherein $\frac{1}{m}$ is Poisson's ratio. This second error of neglect actually would not have been necessary since it is not at all difficult to introduce the factor $\frac{m^2}{m^2 - 1}$ into the calculation. It will be seen, however, that this second error of neglect is partially compensated for by the first.

I have carried out the more exact calculation and, in order to have a basis for comparison, I have considered the reduced stress as the measure of working stress of the material. The exact calculation always yields lower working stresses than the foregoing method of calculation; as a matter of fact, the differences Δ in percentages amount to :

$\frac{b^2}{rd} = 0.0$	0.1	0.2	0.3	0.4	0.5	0.6	1.0	5.0	
$\Delta \%$	0	8.3	14.8	14.9	6.3	6.1	5.7	4.7	4.3

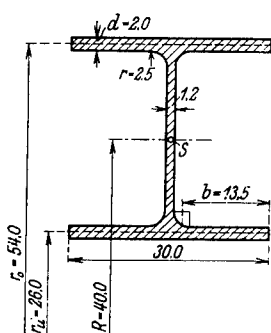

Figure 10a

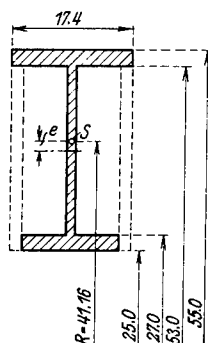

Figure 10b

Numerical example: An IP 30 with a radius of curvature $R = 40$ cm (measured to the center of gravity) is to be subjected to the moment $M = -7.5$ tm and the longitudinal force $N = -10$ t; $d = 2.0$ cm (Figure 10a); the width of the projecting parts, if half the fillet is deducted, amounts to $b = 13.5$ cm; the radii of curvature of the flange

*Translator's note: This term apparently refers to the case of a face plate riveted to the web by means of angle members.

axes are $r_o = 54$ cm, $r_u = 26$ cm.*

For the upper flange $\frac{b^2}{rd} = 1.69$, $\nu = 0.523$, $\mu = 1.722$,

For the lower flange $\frac{b^2}{rd} = 3.50$, $\nu = 0.390$, $\mu = 1.675$

The flange widths of the ideal cross section are

$$B_o = 2 \cdot 13.5 \cdot 0.523 + 1.2 + 1.8 = 17.4 \text{ cm,}$$

$$B_u = 2 \cdot 13.5 \cdot 0.390 + 1.2 + 1.8 = 13.5 \text{ cm}$$

In view of this sharp curvature, the reduction is quite considerable. The ideal cross section is indicated in Figure 10b. We calculate the quantities F and Z by neglecting the fillets.

$$F = 91.4 \text{ cm}^2$$

The displacement of the center of gravity amounts to

$$e = \frac{2(17.4 - 13.5) \cdot 14.0}{91.4} = 1.16 \text{ cm}$$

The radius of curvature R measured to the new gravity axis is therefore

$$R = 41.16 \text{ cm}$$

If the division into rectangles is performed in such a way that two small rectangles are deducted from each side, Equation [6'] yields

$$Z = 41.16^3 \left[17.4 \cdot \log \text{nat} \frac{55}{25} - 3.9 \cdot \log \text{nat} \frac{53}{25} - 12.3 \cdot \log \text{nat} \frac{53}{27} \right] - 41.16^2 \cdot 91.4 = 23,700 \text{ cm}^3$$

Hence, according to Equation [5], the surface stresses are

$$\sigma_o = -\frac{10}{91.4} + \frac{750}{41.16 \cdot 91.4} + \frac{750}{23,700} \cdot 41.16 \cdot \frac{13.84}{55} = +0.419 \text{ t/cm}^2,$$

$$\sigma_u = -\frac{10}{91.4} + \frac{750}{41.16 \cdot 91.4} - \frac{750}{23,700} \cdot 41.16 \cdot \frac{16.16}{25} = -0.751 \text{ t/cm}^2$$

We still need the stresses at the distance $\frac{d}{2} = 1$ cm from the upper or lower surface respectively in order to be able to calculate the additional bending stresses. According to Equation [5] with $v_o = 12.84$, $v_u = -15.16$ cm

$$\text{in the upper flange } -\bar{\sigma}_m = +0.401 \text{ t/cm}^2,$$

$$\text{in the lower flange } \bar{\sigma}_m = -0.669 \text{ t/cm}^2$$

Hence, the additional bending stresses $\sigma' = \mu \bar{\sigma}_m$ on the external surfaces amount to

$$\sigma'_o = 1.722 \cdot 0.401 = +0.691 \text{ t/cm}^2,$$

$$\sigma'_u = 1.675 \cdot 0.669 = +1.121 \text{ t/cm}^2$$

*Translator's note: The subscripts o and u apparently stand for 'oben' and 'unten', meaning 'above' and 'below', viz upper and lower radius.

If one uses the reduced stress $\sigma_{red} = \sigma_1 - 0.30 \sigma_{II}$, as determining the working stress, it follows that

$$\begin{aligned}\sigma_{o red} &= 0.691 - 0.30 \cdot 0.419 = 0.565 \text{ t/cm}^2, \\ \sigma_{u red} &= 1.121 + 0.30 \cdot 0.751 = 1.346 \text{ t/cm}^2\end{aligned}$$

For the sake of comparison, let us calculate the same case according to the method usually employed in steel construction.

According to Figure 10,

$$F = 154 \text{ cm}^2,$$

$$Z = 40^3 \left[30 \cdot \log \text{nat} \frac{55}{25} - 28.8 \cdot \log \text{nat} \frac{53}{27} \right] - 40^2 \cdot 154 = 28720 \text{ cm}^3,$$

$$\sigma_o = -\frac{10}{154} + \frac{750}{40.154} + \frac{750.40}{28720} \cdot \frac{15}{55} = +0.322 \text{ t/cm}^2,$$

$$\sigma_u = -\frac{10}{154} + \frac{750}{40.154} - \frac{750.40}{28720} \cdot \frac{15}{25} = -0.570$$

The stresses $\bar{\sigma}_m$ are now

$$\text{in the upper flange } \bar{\sigma}_m = +0.307 \text{ t/cm}^2,$$

$$\text{in the lower flange } \bar{\sigma}_m = -0.526 \text{ t/cm}^2$$

For the secondary bending stresses the following formula applies:

$$\sigma' = \frac{\frac{d \bar{\sigma}_m}{r} \cdot \frac{b^2}{2}}{\frac{d^2}{6}} = \frac{3 b^2}{r d} \cdot \bar{\sigma}_m,$$

hence

$$\sigma'_o = 5.07 \cdot 0.307 = +1.557 \text{ t/cm}^2,$$

$$\sigma'_u = 10.50 \cdot 0.526 = +5.523 \text{ t/cm}^2$$

whereby the reduced stress on the inner surface is obtained as

$$\sigma_{red} = 5.523 + 0.30 \cdot 0.570 = 5.694 \text{ t/cm}^2$$

which is much higher than permissible, whereas the actual stress amounts to only 1.35 t/cm².

As this example shows, the more exact calculation entails quite a considerable economy in the case of sharply curved beams.