

REPORT DOCUMENTATION PAGE

Form Approved
DMS No. 0704-0188

Public reporting burden for this collection of information is estimated to average 1 hour per response, including the time for reviewing instructions, searching existing data sources, gathering and maintaining the data needed, and completing and reviewing the collection of information. Send comments regarding this burden estimate or any other aspect of this collection of information, including suggestions for reducing the burden, to Washington Headquarters Services, Directorate for Information Operations and Reports, 1215 Jefferson Davis Highway, Suite 1204, Arlington, VA 22202-4302, and to the Office of Management and Budget, Paperwork Reduction Project (0704-0188), Washington, DC 20503.

1. AGENCY USE ONLY (Leave blank)

2. REPORT DATE

March 1994

3. REPORT TYPE AND DATES COVERED

Final Tech. Rep. 2/15/91 - 2/14/94

4. TITLE AND SUBTITLE

TRANSPORT PHENOMENA AND INTERFACIAL KINETICS
IN MULTIPHASE COMBUSTION SYSTEMS

5. FUNDING NUMBERS

PE - 61102F
PR - 2308
SA - BS
G - 91-0170 (AFOSR)

6. AUTHOR(S)

Principal Investigator: Daniel E. Rosner

7. PERFORMING ORGANIZATION NAME(S) AND ADDRESS(ES)

HIGH TEMPERATURE CHEMICAL REACTION
ENGINEERING LABORATORY
YALE UNIVERSITY
BOX 208286 YALE STATION
NEW HAVEN, CONNECTICUT 06520 U.S.A.

8. PERFORMING ORGANIZATION
REPORT NUMBER

AFOSR-91
0170

9. SPONSORING/MONITORING AGENCY NAME(S) AND ADDRESS(ES)

AFOSR/NA
Building 410
Bolling AFB DC 20332-6448

10. SPONSORING/MONITORING
AGENCY REPORT NUMBER

AFOSR-TR-90 97
0023

11. SUPPLEMENTARY NOTES

12a. DISTRIBUTION/AVAILABILITY STATEMENT

Approved for public release; distribution is unlimited

12b. DISTRIBUTION CODE

13. ABSTRACT (Maximum 200 words)

This final technical report summarizes Yale High Temperature Chemical Reaction Engineering Laboratory research activities (under Grant AFOSR 91-0170) for the three-year period ending 14 February 1994. Among our research results described in detail in the cited references (Section 5), perhaps the most noteworthy are the development/reporting of:

- R1 rational methods to predict the accessible surface area and translational Brownian diffusivity of aggregated 'soot' particles in high pressure combustion gases
- R2 experimental inference of particle thermophoretic diffusivities for titania aggregates in laminar counterflow laminar diffusion flames; consequences of particle thermophoresis for flame radiation, flame synthesis, and 'non-biased' thermophoretic sampling
- R3 quantitative methods for predicting/correlating the effects vapor phase chemical reactions on the rate and quality of vapor-deposited ceramic thin films

Thirty verbal presentations, ten archival publications, and three PhDs have resulted from this research program. Additionally, nine papers are submitted or in press. Copies of the principal reprints appearing during the final year of this program are included in the Appendices (Section 6) of this report.

14. SUBJECT TERMS

Key Words: Soot, aggregated particles, mass transport, thermophoresis, particle inertia
Brownian diffusion, chemical vapor deposition, particle sampling,
deposit microstructure/properties

15. NUMBER OF PAGES

44

16. PRICE CODE

17. SECURITY CLASSIFICATION
OF REPORT

Unclassified

18. SECURITY CLASSIFICATION
OF THIS PAGE

Unclassified

19. SECURITY CLASSIFICATION
OF ABSTRACT

Unclassified

20. LIMITATION OF ABSTRACT

UL

19970117 082

TRANSPORT PHENOMENA AND INTERFACIAL KINETICS IN MULTIPHASE COMBUSTION SYSTEMS

Principal Investigator: Prof. Daniel E. Rosner

1. INTRODUCTION

The performance of ramjets burning slurry fuels (leading to condensed oxide aerosols and liquid film deposits), gas turbine engines in dusty or marine atmospheres, or when using fuels from non-traditional sources, depends upon the formation and transport of small particles across non-isothermal combustion gas boundary layers (BLs). Even airbreathing engines burning "clean" hydrocarbon fuels can experience *soot* formation/deposition problems (e.g., combustor liner burnout, accelerated turbine blade erosion and "hot" corrosion). Moreover, particle formation and transport are important in many chemical reactors used to synthesize or process aerospace materials (turbine blade coatings, optical waveguides, ceramic precursor powders, fibers for composites,...). Accordingly, our research is directed toward providing chemical propulsion systems engineers and materials-oriented engineers with new techniques and quantitative information on important particle- and vapor-mass transport mechanisms and rates.

The purpose of this report is to summarize our research methods and accomplishments under AFOSR Grant 91-0170 (Technical Monitor: J.M. Tishkoff) during the 3-year period: 15 February '91-14 February '94. Readers interested in greater detail than contained in Section 2 are advised to consult the published papers explicitly cited in Sections 2 and 5. Copies of any of these published papers (Section 5.2 and Appendix) or preprints (Section 5.3) can be obtained by writing to the PI: Prof. Daniel E. Rosner, at the Department of Chemical Engineering, Yale University, New Haven, CT 06520-8286 USA. Comments on, or examples of, the *applications* of our research (Section 3.4) will be especially welcome.

An interactive experimental/theoretical approach has been used to gain understanding of performance-limiting chemical-, and mass/energy transfer-phenomena at or near interfaces. This included the development and exploitation of seeded laboratory burners (Section 2.1), new optical diagnostic techniques (Section 2.2) and flow reactors (Section 2.4). Resulting experimental rate data, together with the predictions of asymptotic theories (Section 2), were used as the basis for proposing and verifying simple viewpoints and effective engineering correlations with a rational basis for future design/optimization studies.

2. RESEARCH ACCOMPLISHMENTS

Most of the results we have obtained under Grant AFOSR 91-0170 during '91-'94 can be divided into the subsections below:

2.1. TRANSPORT AND STABILITY OF AGGREGATED PARTICLES: THEORY

The ability to reliably predict the transport properties and stability of *aggregated* flame-generated *particles* (carbonaceous soot, Al_2O_3 , SiO_2 ,...) is important to many technologies, including chemical propulsion and refractory materials fabrication. The existence and character of such particles is also known to influence the "signature" of chemical propulsion devices.

The *Brownian diffusion*-, *inertial*-, and *optical-properties* of *aggregated* particles, as formed in sooting diffusion flames, are quite *sensitive* to size (e.g. number N of "primary" particles; see Fig. 1) and morphology (geometrical arrangement of the primary particles). In this program we developed methods to anticipate coagulation and deposition rates of suspended populations of such particles in combustion systems. As one example, we have recently developed improved and efficient methods for predicting the Stokes drag of large 'fractal' aggregates *via* a spatially variable porous sphere model (Tandon and Rosner, 1994; Figs. 1, 2). Using the Stokes-Einstein equation, the results of Fig. 2 have been used to predict the Brownian diffusivity of such aggregates in the high pressure (near continuum-) limit (proportional to the product of the reciprocal of the ordinate of Fig. 2 and N^{-1/D_f}). This approach can be extended to predict the *thermophoretic diffusivity* of such aggregates, an important quantity we have recently found to be much less sensitive to size and morphology than the translational Brownian diffusivity (Rosner *et.al.* 1992). Indeed, this provides the theoretical basis for the *thermophoretic sampling* technique being employed in our current experimental studies (Section 2.2). These new methods/results, together with recent results on the *spread* of aggregate sizes in coagulating populations, can be used to predict wall *capture rates* by the mechanisms of convective-diffusion, turbulent eddy-impaction, and thermophoresis. Also developed in this program were efficient pseudo-continuum methods to predict chemical interactions between aggregates and their surrounding *vapor* environment---interactions which can lead to primary particle growth, or burn-out. In particular, we developed new and efficient methods to predict the "accessible surface area" of aggregates (expressed as a fraction, η , of the true surface area in Fig. 3), including its dependence on size (N), structure (fractal dimension, D_f), probing molecule reaction probability α , and pressure level (*via* Knudsen number based on primary particle diameter)(Rosner and Tandon, 1994).

Initiated in this program were studies of the *restructuring kinetics* of aggregates — *ie.* those factors which determine the observed size of the apparent "primary particles" comprising soot particles, and the "collapse" of surface area observed in some high temperature systems (Cohen and Rosner, 1993). Toward this end, we developed new methods to characterize the morphology of multi-particle aggregates (Fig. 5) thermophoretically extracted from laminar CDFs in a new "slot" type burner (Fig. 4). One such "fingerprint" is the *pdf* of angles formed by triplets of primary particles (Fig. 6).

2.2. FORMATION, TRANSPORT AND STABILITY OF COMBUSTION-GENERATED PARTICLES: LAMINAR COUNTERFLOW DIFFUSION FLAME EXPERIMENTS

We have inferred the *thermophoretic diffusivity* of flame-generated submicron "soot" particles using two-phase flame structure measurements on $(\text{TiCl}_4(\text{g}))$ -seeded low strain-rate counterflow laminar diffusion flames (CDF-) (Gomez and Rosner, 1993). A knowledge of the relative positions of the gas and particle stagnation planes and the associated thermal and chemical environments can be used to control the composition and morphology of flame-synthesized particles. These factors should also influence particle production and *radiation* from *turbulent* non-premixed "sooting" flames, as discussed further in Gomez and Rosner, 1993.

To obtain fundamental information on nucleation, growth and aggregate restructuring, we developed an improved "slot-type" burner (Fig. 4) and introduced instruments to carry out *in situ* measurements of particle Brownian motion (*via* "dynamic light scattering"). We also developed a thermophoretic sampler to extract aggregates from various positions in the seeded-CDF for morphological analysis using transmission electron microscope (TEM) images (Fig. 5). Aggregate data obtained from CH_4 flames seeded with titanium tetraisopropoxide (TTIP-) vapor are being being analyzed using new theoretical methods briefly outlined in Sections 2.1, 2.3.

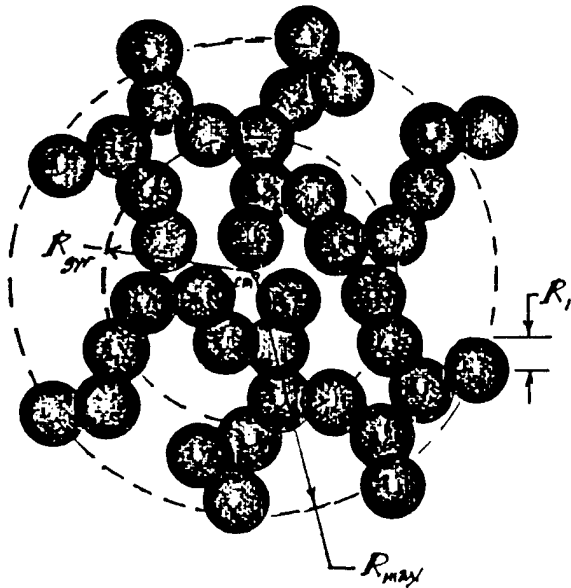

Fig.1 "Porous sphere" model of large fractal aggregate suspended in a background gas; basis for the calculation of translational and rotational Brownian diffusion coefficients, thermophoretic diffusivity, "stopping time", accessible area, and restructuring kinetics (after Rosner and Tandon, 1993, Rosner, Cohen and Tandon, 1993, Tandon and Rosner, 1994)

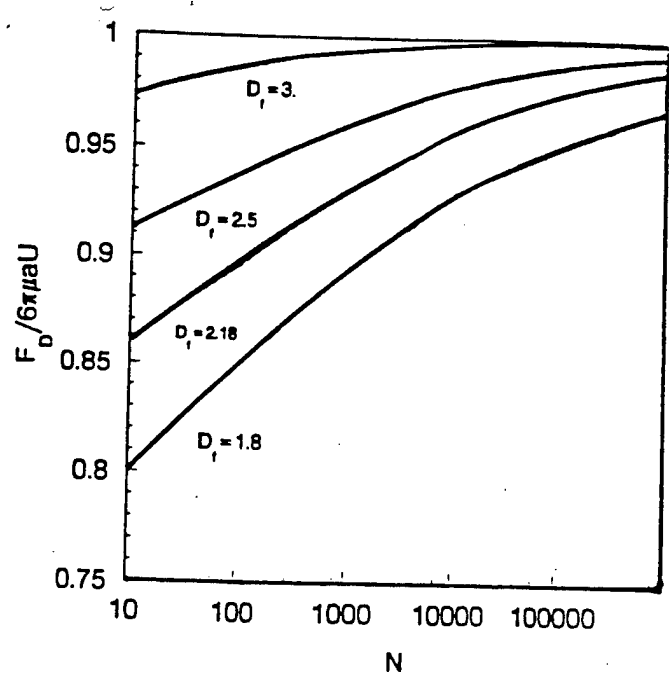

Fig. 2 Drag reduction associated with effective permeability for a quasi-spherical "fractal" aggregate comprised of N primary spheres in the continuum regime ($a = R_{max} = \{(3/2) \cdot [D_f + 2] / D_f\}^{1/2} R_{gyration}$) (after Tandon and Rosner, 1994)

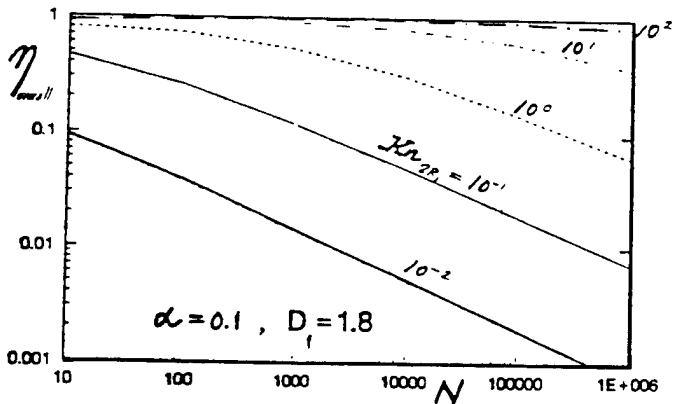

Fig. 3 Pressure dependence (via the Knudsen number based on primary sphere diameter) of the accessible surface area of large "open" ($D_f=1.8$) aggregates; reaction probability, α , of probing molecule 0.1; (after Rosner and Tandon, 1994)

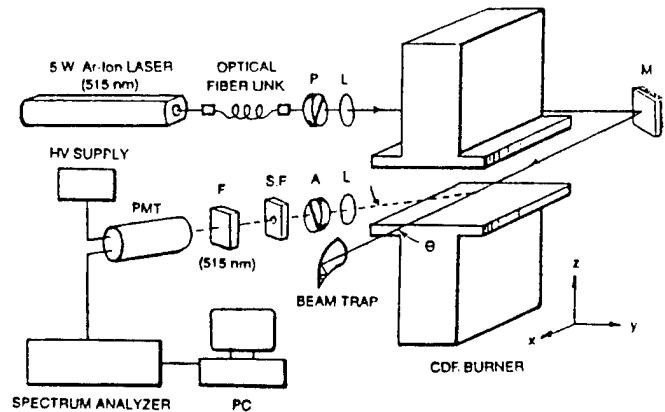
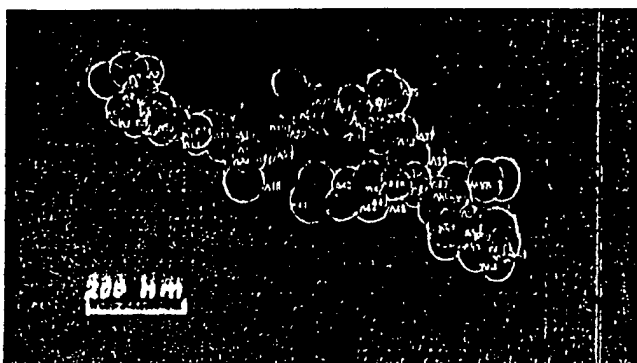

Fig.4 "Slot"-type counterflow diffusion flame (CDF-) burner set-up for *in situ* and extractive experimental studies of the nucleation, growth, transport and restructuring of aggregates in flames (after Albagli, Xing and Rosner, 1994; see, also Gomez and Rosner, 1993)



a



b

Fig. 5 Typical multiparticle aggregate thermophoretically extracted from laminar CDF seeded with TiO_2 precursor TTIP vapor. TEM image (a) compared to 'touching sphere' idealization (b) (after Albagli, Xing and Rosner, 1994)

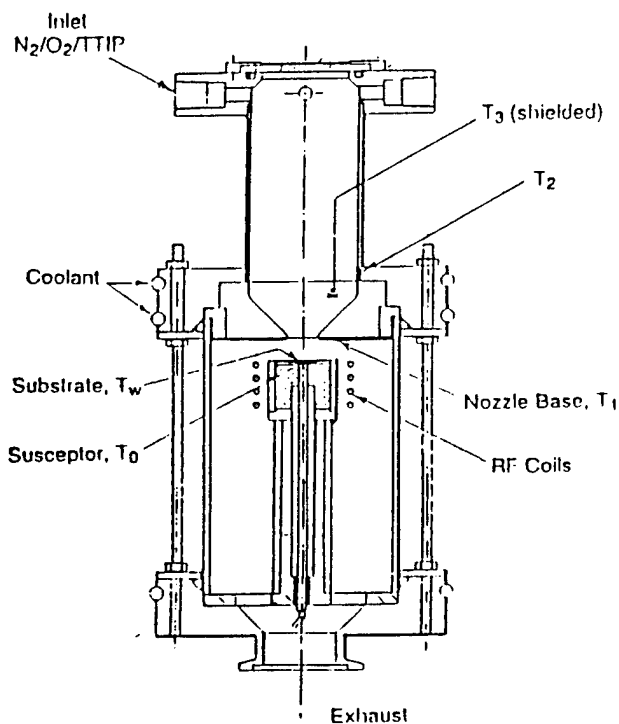

Fig. 7 Axisymmetric impinging jet CVD-reactor with inductively heated "pedestal" (after Rosner, Collins and Castillo, 1993, Collins, 1994) for systematic studies of oxide film deposition from the vapor precursor TTIP

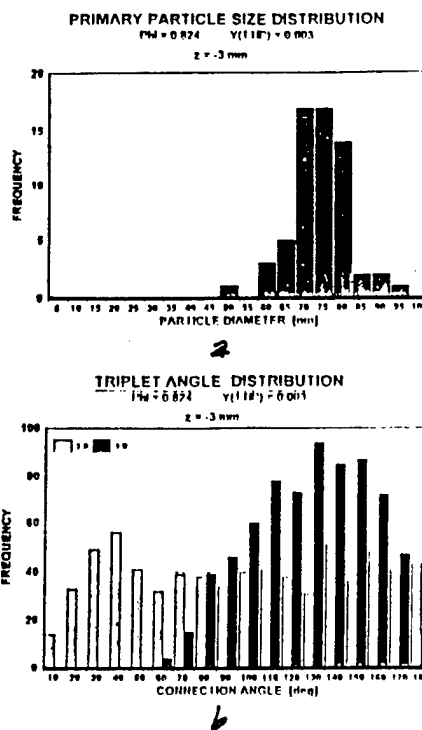

Fig. 6 Aggregate characterization techniques; (a) *pdf* of primary particle diameters; (b) *pdf* of angles formed between triplets of contacting primary particles (2D: based on projected TEM image, 3D: corrected for three dimensionality of real aggregate) needed for restructuring kinetics analysis (Cohen and Rosner, 1993, 1994)

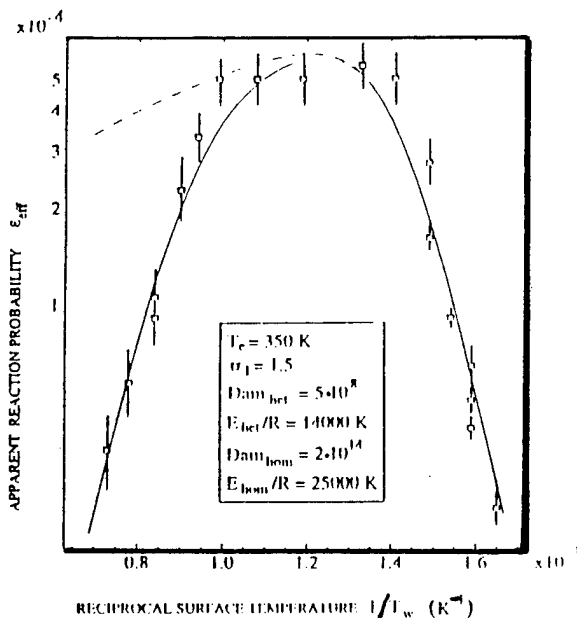

Fig. 8 $\text{TiO}_2(\text{s})$ deposition rate data (reported as an apparent first order heterogeneous rate constant) from $\text{TTIP}/\text{O}_2/\text{N}_2$ mainstream showing 'best-fit' deposition rates (after Rosner, Collins and Castillo, 1993, Castillo and Rosner, 1994) predicted using chemical sublayer (CSL-) theory, allowing for homogeneous consumption of TTIP within thermal BL.

2.3. MULTIPHASE TRANSPORT THEORY: NUCLEATION, GROWTH, THERMOPHORESIS AND INERTIA; AEROSOL SAMPLING IMPLICATIONS

In this program we have completed and submitted for *IJHMT* publication a comprehensive set of seeded micro-combustor experiments, and ancillary theoretical calculations on the interesting competition between particle *inertia* and particle *thermophoresis* for the case of particle transport across laminar nonisothermal gaseous boundary layers on surfaces with streamwise curvature (*e.g.*, turbine blades). (Konstandopoulos and Rosner, 1994). For *inertial impaction* we demonstrated that our earlier idea of correlating impingement rates from compressible gas flows using an *effective Stokes number* (Israel and Rosner, 1983) can be generalized to include the effects of aerodynamically interacting targets, as in a 'cascade' of turbine blades (Konstandopoulos, Labowsky and Rosner, 1993).

We also completed and published a computational study of the *unusual population dynamics* of coagulating absorbing-emitting particles in strong *radiation fields* (Mackowski *et al.*, 1994). (For a useful overview of our recent AFOSR-supported work on these and other effects of energy transfer on suspended particle dynamics, see Rosner, *et al.*, 1992).

The systematic effects of particle size/morphology-dependent wall deposition and coagulation on the sampling of aerosols have been predicted and discussed in 2 papers, one (Rosner and Tassopoulos, 1992) which appeared during this period, and one now in preparation (Rosner, Tandon and Konstandopoulos, 1994).

2.4. KINETICS AND MORPHOLOGY OF CVD-MATERIALS IN MULTI-PHASE ENVIRONMENTS

A small impinging jet (stagnation flow) reactor (Fig.7) has been developed and used to study the chemical vapor deposition (CVD-) rates of refractory layers on inductively (over-)heated substrates (Collins, Rosner and Castillo, 1992, 1993; Collins, 1994). These measurements, initiated with the co-sponsorship of NASA-Lewis Labs, have been used to understand deposition rates and associated deposit microstructures observed in highly non-isothermal, often particle-containing local CVD environments. Figure 8 shows (logarithmic ordinate) our apparent deposition rate probabilities *vs.* reciprocal surface temperature for $\text{TiO}_2(\text{s})$ obtained from $\text{TTIP}(\text{g})$. The solid curve marked $\text{Dam}_{\text{hom}} = 2 \times 10^{14}$ (where this parameter may be regarded as a dimensionless homogeneous rate constant) shows our predicted CVD rate behavior including non-negligible Soret transport (Castillo and Rosner, 1993) allowing for TTIP decomposition *within* the boundary layer. Agreement with the experimental data of Collins (1994) is encouraging indeed. Regarding deposit surface morphology, we completed a theoretical study of the morphological stability of deposits growing by the mechanism of thermophoresis (or Soret transport for vapors) (chemical sublayer (CSL-) theory of Castillo, Garcia-Ybarra and Rosner, 1992). On the subject of the 'grain' density of vapor deposits we proposed and successfully demonstrated a rational correlation which relates the density of 7 materials (including SiC, BN and graphite) for which data could be found in the literature to their fundamental properties (activation energy for surface diffusion, lattice dimensions,...) and deposition conditions (reactant pressure, surface temperature, reaction probability) *via* a suitable Damkohler number which we call the 'burial' parameter (Kho, Collins and Rosner, 1994).

In this program we have also summarized our research on the high temperature gasification kinetics of solid boron by $\text{B}_2\text{O}_3(\text{g})$, including the implications of our flow reactor data for chemical propulsion applications (Gomez, Rosner, and Zvuloni, 1993).

In our OSR-sponsored Yale HTCRES Lab research during this program, briefly reviewed here, we have shown that new methods for rapidly measuring particle transport rates, combined with recent advances in boundary layer theory, provide useful means to

identify and incorporate important, but often previously neglected, mass transport phenomena in many multiphase propulsion engineering and materials engineering design/optimization calculations.

Despite the formidable complexities to be overcome in the design and operation of air-breathing propulsion power plants utilizing a broad spectrum energetic fuels these particular techniques and results are indicative of the potentially useful simplifications and generalizations which have emerged from this program's fundamental AFOSR-funded research studies of combustion-generated particle transport mechanisms. It is hoped that this Final Report and its supporting (cited) papers will facilitate the refinement and/or incorporation of some of the present ideas into engineering design procedures of much greater generality and reliability. This work has already helped identify new directions where research results could have a significant impact on engineering practice in both the defense and civilian sectors of the US economy (Section 3.4).

3. ADMINISTRATIVE INFORMATION: PERSONNEL, PRESENTATIONS, APPLICATIONS, "COUPLING' ACTIVITIES

The following sections summarize some pertinent 'non-technical' facets of the abovementioned Yale HTCRC Lab/AFOSR research program:

3.1 Personnel

The present results (Sections 2 and 5) are due to the contributions of the individuals listed in Table 3.1-1, which also indicates the role of each researcher and the relevant time interval of the activity. It will be noted that, in addition to the results themselves, this program has simultaneously contributed to the research training of a number of students and 3 recent PhDs, who will now be in an excellent position to make future contributions to technologies oriented toward air-breathing chemical propulsion, and high-tech materials processing.

Table 3.1-1 Summary of *Research Participants^a* on AFOSR Grant :

TRANSPORT PHENOMENA AND INTERFACIAL KINETICS IN MULTIPHASE COMBUSTION SYSTEMS

Name	Status ^a	Date(s)	Principal Research Activity ^b
Albagli, D.	PDRA	4/92-5/94	particle prod/char. in CDFs
Cohen, R. D.	VS	Spring'93	aggregate restructuring theory
Collins, J.	GRA	'92-'94	CVD of ceramic coatings
Gomez, A.	Asst.Prof.	'92	Ms. on particle transp. props.(CDFs)
Kho,T.	GRA	'92-'94	correl. of density of CVD coatings
Konstandopoulos, A	GRA,PDRA	'92, '93	combined inertia + thermophoresis
Labowsky, M. J.	VS	'91-'94	inertial impaction and erosion
Papadopoulos, D	GRA	'92-'94	boundary conditions at G/S interface
Rosner, D.E.	PI	'91-'94	program direction-dep. theory/exp
Silverman, I.	PDRA	'92-'93	spray evap/comb. at high pressures
Tandon, P.	GRA	'92-'94	transport phenom. in BLs and CDFs
Xing, Y.	GRA	'93-'94	particle prod/char. in CDFs

^a PDRA=Post-doctoral Research Asst GRA= Graduate Research Assistant
PI = Principal Investigator VS = Visiting Scholar

^b See Section 5 for specific references cited in text (Section 2)

3.2 Cooperation with US Industry

The research summarized here was supported by AFOSR under Grant 91-0170 (2/15/91-2/14/94). The Yale HTCRES Laboratory has also been the beneficiary of continuing smaller grants from U.S. industrial corporations, including groups within GE, DuPont, Union Carbide (now Advanced Ceramics Corp.) and Shell, as well as the feedback and advice of principal scientists/engineers from each of these corporations and Combustion Engineering-ABB and Textron. We appreciate this level of collaboration, and expect that it will accelerate inevitable applications of our results in areas relevant to their technological objectives (see, also, Section 3.4, below).

3.3 Presentations and Research Training

Apart from the publications itemized in Section 5 and our verbal presentation (of progress) at the regular AFOSR Contractors Meetings, our results have also been presented at some 30 seminars/conferences--including annual or topical conferences of the following professional organizations:

Int. Fine Particle Res. Inst. (6/92, 6/93)
AIChE (11/91, 11/92, 11/93)
AAAR (10/93)
Electrochemical Soc. (CVD XI (5/91), XII; 5/20/93)
ASME-Engineering Foundation (3/91)
Materials Research Society
Combustion Inst.

In addition, during the period: 2/15/91-2/14/94, the PI presented seminars at the following Universities:

U Manchester 5/28/92	Leeds 5/29/92	Penn State (7/28/92)
Northwestern 4/22/93	CUNY 10/18/93	KTH-Stockholm
Brown (9/22/92)	Notre Dame (10/27/92)	U. Paris-Nord.
U. Wisconsin	U. Oslo	U. Limoges
Trondheim	U. Toulouse	Technion-Haifa
Waterloo		

This program involved completion of the PhD dissertation research of three Yale graduate students (J. Collins, A.G. Konstandopoulos and M. Tassopoulos; cf. Table 3.1-1) and will form the basis of the dissertation of P. Tandon (to be completed during '94-'95). Also, T. Kho has received her Master's Degree based on work supported in this program.

3.4 Some Known Applications of Yale-HTCRE Lab Research Results

It has been particularly gratifying to see direct applications of some of this generic AFOSR-supported particle and vapor mass transfer research in more applications-oriented

investigations reported in recent years. Indeed, *the writer would appreciate it if further examples known to the reader can be brought to his attention.*

Our AFOSR supported research on *soot deposition rates* from flowing laminar or turbulent combustion gases has been applied by Aerojet Corp. (D. Makel *et.al.*, 1990) to develop a model for application to rocket chambers and nozzles (with NASA support). Extensions to jet engine nozzles are currently being made by M.T. Nys at Pratt and Whitney Engine Business in W. Palm Beach FL

In the area of multicomponent vapor deposition in combustion systems applications of our predictive methods (for "chemically frozen" (Rosner *et.al.*, 1979) and LTCE multicomponent laminar boundary layers) have been made by British Coal Corporation-Power Generation Branch (I. Fantom, contact) in connection with their topping cycles which run gas turbines on the products of fluidized bed coal combustors/gasifiers. Also, in combustion research many groups (*eg.*, Dobbins *et.al.* (Brown U.), Faeth *et.al.* (U. Mich.), Katz *et al.* (J. Hopkins U.)) are now utilizing "thermophoretic sampling" techniques to exploit the size- and morphology-insensitive capture efficiency characteristics that we have proven in our AFOSR research (Section 2.1).

Our AFOSR and NASA fundamental research on chemical element segregation in the CVD of refractory ceramics (*eg.*, SiC and metal borides) (*see, eg.*, Collins and Rosner, 1991, 1992) is evidently of use to AFML contractors synthesizing controlled stoichiometry fibers for light weight/high strength composites (Americom, Textron).

For calculating suspended particle concentrations along trajectories outside of aircraft (involved in atmospheric sampling), or inside of CVD reactors, A. S. Geller and D. J. Rader of Sandia-Albuquerque have adopted a method developed in our earlier AFOSR work (Fernandez de la Mora, 1981), and recently applied in our own studies of particle motion in laminar boundary layers with streamwise curvature (Konstandopoulos and Rosnert, 1994).

Ongoing work at MIT (Walsh *et.al.* 1992), PSI (J.J.Helble) and Sandia CRF (L.L. Baxter) has incorporated our rational correlation of *inertial particle impaction* (*e.g.* a cylinder in cross-flow) in terms of our *effective Stokes number* (Israel and Rosner, 1983, and Konstandopoulos *et. al.* 1993). Recent applications of our AFOSR and DOE-supported research (on the correlation of inertial impaction by cylinders in crossflow) have also been made by the National Engineering Laboratory (NEL) of Glasgow Scotland (Contact: Dr. A. Jenkins). NEL is apparently developing mass-transfer prediction methods applicable to waste-heat recovery systems in incinerators, as well as pulverized coal-fired boilers. These applications are somewhat similar to those reported by the Combustion R&D group at MIT and Penn State U, and are now being taken up by VTT-Energy/Aerosol Technology Group, in Finland.

Explicit use of our studies of self-regulated "capture" of incident impacting particles (Rosner and Nagaragan, 1987) is being made in current work on impact separators and ceramic heat exchangers for coal-fired turbine systems in high performance stationary power plants. Other potential applications arise in connection with "candle filters" used to remove fines (sorbent particles,...) upstream of the turbines. A useful summary of work in these interrelated areas (Solar Turbines, Textron Defense Systems, Hague International,...) was

presented at the Engineering Foundation Conference *Inorganic Transformations and Ash Deposition During Combustion.*, the proceedings of which appeared in 1992.

Clearly, fruitful *opportunities* for the application of our recent "non-Brownian" convective mass transfer research now exist in many of the programs currently supported by the US Air Force, as well as civilian sector R&D.

4. CONCLUSIONS

In the OSR-sponsored Yale HTCRES Lab research during the period: 2/15/91-2/14/94, briefly described above, we have shown that new methods for rapidly measuring particle-mass transfer rates, combined with our recent advances in mass transport theory, provide useful means to identify and incorporate important, but previously neglected, mass transport phenomena in many chemical propulsion engineering and materials engineering design/optimization calculations. One important class of examples involve our treatment of aggregated particle transport phenomena (Section 2.1)

Despite formidable complexities to be overcome in the design and operation of mobile and stationary power plants utilizing a broad spectrum of energetic fuels the abovementioned techniques and results (Section 2) are indicative of the potentially useful simplifications and generalizations emerging from our present fundamental AFOSR-funded research studies of combustion-generated particle transport mechanisms and interfacial reactions relevant to the synthesis of refractory materials. It is hoped that this Final Report and its supporting papers (Section 5) will facilitate the incorporation of many of the present ideas into design and test procedures of greater generality and reliability. This work has also helped identify new directions where it is anticipated that research results from this AFOSR program have a significant impact on future DOD and civilian sector engineering practice.

5. REFERENCES

5.1 CITED BACKGROUND PUBLICATIONS (Predecessor OSR, DOE-Grants)

- Eisner, A.D. and Rosner, D.E., "Experimental Studies of Soot Particle Thermophoresis in Non-Isothermal Combustion Gases Using Thermocouple Response Techniques", *Combustion and Flame* **61**, 153-166(1985); see, also: *J PhysicoChemical Hydrodynamics* (Pergamon) **7**, 91-100 (1986)
- Fernandez de la Mora, J. and Rosner, D.E., "Inertial Deposition of Particles Revisited and Extended: Eulerian Approach to a Traditionally Lagrangian Problem", *PCH Physicochemical Hydrodynamics* (Pergamon) **2** (1), 1-21, (1981)
- Geller, A.S., Rader, D.J. and Kempka, S.N., "Calculation of Particle Concentration Around Aircraft-Like Geometries", *J. Aerosol Sci.* **24** (6) 823-834 (1993)
- Rosner, D.E. and Kim, S.S., "Optical Experiments on Thermophoretically Augmented Submicron Particle Deposition From 'Dusty' High Temperature Gas Flows", *The Chemical Engrg. J.*(Elsevier) **29**,[3], 147-157 (1984)

Rosner, D.E. and Nagarajan. R., "Toward a Mechanistic Theory of Net Deposit Growth from Ash-Laden Flowing Combustion Gases: Self-Regulated Sticking of Impacting Particles and Deposit Erosion in the Presence of Vapor 'Glue'", *Proc. 24th National Heat Transfer Conf.*, AIChE Symposium Series, Vol. 83 [257], 289-296, (1987)

Rosner, D. E. , Chen, B.K., Fryburg, G.C. and Kohl, F.J., "Chemically Frozen Multicomponent Boundary Layer Theory of Salt and/or Ash Deposition Rates from Combustion Gases", *Combustion Science and Technology* 20, 87-106 (1979)

Rosner, D.E., **Transport Processes in Chemically Reacting Flow Systems**, Butterworth-Heinemann, Stoneham MA, 1986; 3d Printing 1990.

Rosner, D.E., Mackowski, D.W and Garcia-Ybarra, P., "Size and Structure-Insensitivity of the Thermophoretic Transport of Aggregated 'Soot' Particles in Gases", *Comb. Sci & Technology* 80 (1-3), 87-101 (1991).

Sung, C. J., Law, C. K., and Axelbaum, R. L., "Thermophoretic Effects on Seeding Particles in LDV Measurements of Flames", *Combustion Science and Technology* (submitted, 1993)

Walsh, P.M., Sarofim, A. F., and Beer, J.M., "Fouling of Convection Heat Exchangers by Lignitic Coal Ash", *Energy and Fuels (ACS)* 6 (6) 709-715 (1992)

5.2 PUBLICATIONS WHICH APPEARED* BASED IN PART ON GRANT AFOSR 91-0170

Castillo, J.L., Garcia-Ybarra, P., and Rosner, D.E., "Morphological Instability of a Thermophoretically Growing Deposit", *J. Crystal Growth* 116, 105-126, (1992)

Collins, J., Rosner, D. E. and Castillo, J.L., "Onset Conditions for Gas Phase Reaction and Nucleation in the CVD of Transition Metal Oxides", *Materials Research Soc. Symposium Proceedings* Vol. 250, MRS (Pittsburgh PA) (1992), pp. 53-58

Collins, J., **Effects of Homogeneous Reaction on the Chemical Vapor Deposition of Titanium Dioxide**, PhD Dissertation, Yale University-Graduate School, Dept. Chemical Engineering, 1994

Rosner, D. E., Collins, J. and Castillo, J.L., "Onset Conditions for Gas Phase Reactions and Particle Nucleation/Growth in CVD Boundary Layers", in *Proc. Int. Conf. on CVD (XII)*, 1993, pp 41-47.

Gomez, A., and Rosner, D.E., "Thermophoretic Effects on Particles in Counterflow Laminar Diffusion Flames " *Combustion Science and Technology* 89, 335-362 (1993)

Gomez, A., Rosner, D.E. and Zvuloni, R., "Recent Studies of the Kinetics of Solid Boron Gasification by B₂O₃(g) and Their Chemical Propulsion Implications", *Proc. 2d Int. Sympos. on Special Topics in Chemical Propulsion: Combustion of Boron-Based Solid Propellants and Solid Fuels*, (1992), pp 113-132.

*During this reporting period; Full papers for the 3d (final) year are reproduced in Section 6 (with Forms 298)

Rosner, D.E., Konstandopoulos, A.G., Tassopoulos, M., and Mackowski, D.W., "Deposition Dynamics of Combustion-Generated Particles: Summary of Recent Studies of Particle Transport Mechanisms, Capture Rates, and Resulting Deposit Microstructure/Properties", *Proc. Engineering Foundation Conference: Inorganic Transformations and Ash Deposition During Combustion*, Engrg. Foundation/ASME, NYC (1992); pp. 585-606

Konstandopoulos, A.G., Labowsky, M J., and Rosner, D.E., "Inertial Deposition of Particles From Potential Flows Past Cylinder Arrays", *J. Aerosol Sci* (Pergamon) **24** (4) 471-483 (1993)

Mackowski, D.W., Tassopoulos, M. and Rosner, D.E., "Effect of Radiative Heat Transfer on the Coagulation Dynamics of Combustion-Generated Particles", *Aerosol Sci. Technol.*(AAAR) **20** (1) 83-99,(1993))

Rosner, D.E. and Tassopoulos, M., " Direct Solutions to the Canonical 'Inverse' Problem of Aerosol Sampling Theory: Coagulation and Size-dependent Wall Loss Corrections for Log-Normally Distributed Aerosols in Upstream Sampling Tubes", *J. Aerosol Sci.* **22** (7) 843-867 (1991).

Rosner, D.E., Mackowski, D.W., Tassopoulos, M., Castillo, J.L., and Garcia-Ybarra, P., "Effects of Heat Transfer on the Dynamics and Transport of Small Particles in Gases", *I/EC -Research (ACS)* **31**,760-769 (1992)

5.3 PAPERS IN PREPARATION OR SUBMITTED FOR PUBLICATION

Albagli, D., Xing, Y. and Rosner, D.E., "Factors Governing the Accessible Surface Area of Combustion-Generated Ultrafine Particles" (in preparation, 1994)

Cohen, R. D., and Rosner, D. E. , "Kinetics of Restructuring of Large Multiparticle Aggregates"
(in preparation, 1994; Preliminary version presented at 10/93 AAAR Mtg.))

Castillo, J. L. and Rosner, D.E., Role of High Activation Energy Homogeneous Chemical Reactions in Affecting CVD-Rates and Deposit Quality for Heated Surfaces", in preparation
for *Chem Eng. Sci.*, 1994)

Konstandopoulos, A.G. and Rosner, D.E., "Inertial Effects on Thermophoretic Transport of Small Particles to Walls With Streamwise Curvature---I. Experiment, II. Theory", Accepted 1993 and in press, *Int. J. Heat Mass Transfer* (Pergamon)

- Kho, T. , Collins, J. and Rosner, D. E., "Development, Preliminary Testing, and Future Applications of a Rational Correlation for the Grain Densities of Vapor-Deposited Materials"
(in preparation for submission to *J. Materials Sci.*, 1994)
- Kho, T., Rosner, D.E., and Tandon, P., "Simplified Erosion Rate Prediction Technique for Cylindrical Targets in the High Speed Crossflow of Abrasive Suspensions", (in preparation, for submission to *ASME Trans-J. Engrg. Gas Turbines and Power*, 1994)
- Park, H.M., and Rosner, D.E., "Thermophoretically Induced Phase Separation in Highly-Loaded 'Dusty' Gas Mixtures" (Revised version of HTCRES #162, revision in preparation 1994)
- Rosner, D.E. and Tandon, P., "Diffusion and Heterogeneous Reaction in Large Multi-particle Aggregates; Calculation and Correlation of 'Accessible' Surface Area", (accepted; to appear *AIChE J.* summer '94)
- Rosner, D.E., Tandon, P. and Konstandopoulos, A.G., "Rational Prediction of Inertially Induced Particle Deposition Rates for a Cylindrical Target in Dust-Laden Streams", (in preparation, to be submitted to *Chem. Eng. Sci.*, summer 1994); see, also: Proc. 1st Int. Particle Technology Forum, AIChE (in press, 1994).
- Rosner, D. E., Tandon, A.G., and Konstandopoulos, A.G., "Local Size Distributions of Particles Deposited by Inertial Impaction on a Cylindrical Target in Dust-Laden Streams", (in preparation, to be submitted to *J. Aerosol Sci.*, 1994)
- Rosner, D.E., Tassopoulos M., and Tandon, P. , "Sensitivity of Total Mass Deposition Rate and Resulting Deposit Microstructure to Morphology of Coagulation-Aged Aerosol Populations of Aggregated Primary Particles", in preparation, 1994)
- Zvuloni, R., Rosner, D.E., and Gomez, A., "High Temperature Kinetics of Solid Boron Gasification By its Higher Oxide $B_2O_3(g)$: Flow Reactor Techniques, Rate Measurements and Their Chemical Implications", *J. Phys. Chem.* (to be submitted, 1994)

LIST OF ABBREVIATIONS

BL	Boundary layer	CDF	Counterflow diffusion flame
CVD	Chemical vapor deposition	CRF	Combustion Research Facility
Dam	Damköhler number	CSL	Chemical sublayer
G/S	Gas/solid interface	GRA	Graduate research Asst.
IJHMT	Int. J. Heat/Mass Xfer	PSD	Particle size distribution
LDV	Laser Doppler Velocimetry	LTCE	local thermochemical equilibrium
MRS	Materials Research Society	TTIP	Titanium tetra-isopropoxide
TEM	Transm. Electron μ -scope	<i>pdf</i>	Probability density function

6. APPENDICES (Complete Papers Published During 2/15/93-2/14/94 Period; including Form 298 for each)