

AECD - 1789

UNITED STATES ATOMIC ENERGY COMMISSION

OPERATION MANUAL FOR ROCHESTER ION METER AND ACCESSORY CHAMBERS

by  
W. F. Bale

University of Rochester

**DISTRIBUTION STATEMENT A**  
Approved for public release  
Distribution Unlimited

APR 21 1948  
UNIVERSITY OF ROCHESTER  
LIBRARY

Date Declassified: March 3, 1948

Issuance of this document does not constitute authority for declassification of classified copies of the same or similar content and title and by the same author.

Technical Information Branch, Oak Ridge, Tennessee  
AEC, Oak Ridge, Tenn., 3-30-49--850-A3608

Printed in U.S.A.  
PRICE 10 CENTS

215391

19970122 027

THIS QUANTITY EXCEEDED 2

## OPERATION MANUAL FOR ROCHESTER ION METER AND ACCESSORY CHAMBERS

By W. F. Bale

This instrument is designed for the detection and measurement of a group of ionizing radiations. Interchangeable ionization chambers have been constructed for the measurement of (1) beta and gamma radiations, (2) surface and hand monitoring of alpha radiations, (3) alpha and beta radiation of dust samples collected in precipitron tubes, and (4) fast neutrons.

Moderate to high radiation intensities are measured by direct continuous deflection of a microammeter indicating changes in plate current of a 1LN5 tube used as an electrometer tube. Low intensities of radiation are measured by allowing the charge due to the ionization current to collect on one plate of a condenser. The other plate connects to the grid of the electrometer tube and to ground through a high resistance. During the period of charge collection the two condenser plates are electrically shielded from one another by a grounded metal vane inserted between them. On removing this vane the charge on the first plate of the condenser is communicated to the second plate and thus to the tube grid. A transient meter deflection then occurs proportional to the product of ionization current and ion collection time.

A two pole, triple throw switch allows the output meter to be connected in test 1 position to measure screen grid current, in test 2 position to set tube voltages to reproducible values, and in "Operate" position to measure changes in plate current.

### OPERATION OF ROCHESTER ION METER

#### Steady Deflection Method

1. Lock direct reading switch and chamber ground switch in raised position.
2. Make certain that ballistic control switch is locked in extreme clockwise position with vane stop.
3. Move main switch to "ON" position.
4. Set bar test switch to "TEST 1" position. Adjust control 1 until meter reads 40.
5. Set bar test switch to "TEST 2" position. Adjust control 2 until meter reads 40.
6. Recheck test 1, adjusting control if necessary.
7. After 1 minute recheck, and if necessary readjust test 2, test 1 and test 2 in this sequence.
8. With bar switch in "Operate" position adjust meter to zero with zero adjust.

(Optional) Throw sensitivity switch to test position. Meter should come to rest at 40. Reset sensitivity test switch to operate position. Meter should return to zero.

9. Meter is now in operating condition. During operation, occasionally, in the absence of radiation, check test 1 and test 2 readings, adjusting control 1 and control 2 if necessary, so that meter reads 40 in these positions. Also occasionally check zero reading in "Operate" position in absence of radiation.

### Direct Reading of Hard Beta Radiation

Measurements of hard beta radiation are made with the cylindrical Lucite chamber. The front of this chamber is thin enough (about 1 mm Lucite thick) to allow the entrance of hard beta-rays, for example the radiation associated with UX<sub>1</sub>, UX<sub>2</sub>. The instrument is, therefore, suited to measure beta-ray intensities from surfaces or samples placed in front of the chamber.

#### 10. (Optional) Check of U metal Beta-Ray Standard.

Place brass U metal standard holder on front of chamber, so that U metal is in direct contact with the face of the chamber. The meter should deflect about \_\_\_\_\_ divisions, reaching a stationary reading in about 30 seconds. This is, however, not a large enough reading to be an accurate check on chamber calibration.

11. Place or hold meter in position so that front of ion chamber is in the location where measurement of beta-ray intensity is desired. Read steady meter deflection (at end of about 30 seconds). From direct reading beta-ray conversion chart, read intensity in U units.

A beta-ray U unit is an intensity of beta radiation equivalent to that from a surface of thick U metal in equilibrium with UX<sub>1</sub>, UX<sub>2</sub>. A surface with a measured intensity of 1 U unit in contact with human skin will deliver a daily tolerance dose of approximately 0.5 r equivalent in 2 hours.

12. The beta-ray intensity from movable powdered or liquid samples of material may be measured by filling a 1/2 - inch deep, 4 inches diameter petri dish with the material, and with the unit on end in the wooden stand provided with it, sliding the sample under the end of the ion chamber. The petri dish should be raised to as close to the chamber end as convenient. This distance should not exceed 5/16 inch. If there is also gamma activity present, 1/4-inch clearance should be allowed for later insertion of beta-ray shield.

#### 13. Correction for effects of gamma radiation.

If there is also gamma radiation present in the location where beta measurements are being made, correction for its effects may be made in the following manner. First make beta-ray measurement as directed above. Second, repeat measurements with the same geometric arrangement, except that Lucite beta ray shield is placed on front of chamber to prevent entrance of beta radiation. Using beta-ray conversion chart, subtract from measured beta-ray intensity, apparent beta-ray intensity measured with beta-ray shield in place. The result of this subtraction will be the corrected beta-ray intensity reading.

### Direct Reading Measurements of Gamma Radiation

14. If meter is not already on, turn on as given in steps 1 through 10. Place Lucite beta-ray shield on end of chamber. Using the direct reading gamma conversion chart, meter deflections are recorded as gamma-ray r per 8 hour day.

### Use of Ballistic Vane Method

15. If meter is not already on, turn on as give in steps 1 through 10.

16. Lock first direct reading switch and then ground switch in depressed position.

17. Release ballistic control vane by raising vane stop and locking in raised position. Keep hand on ballistic control knob during preceding step to prevent violent motion of ballistic control. Allow it to turn counterclockwise to rest position. Meter will gradually return to approximately its previous position.

18. When meter is no longer drifting, check test 1 and test 2 positions adjusting controls to produce meter readings of 40 if necessary. With bar knob switch in "Operate" position, adjust meter to zero with zero adjust knob.

19. Release chamber ground and lock in raised position. Turn ballistic control to right, reading final meter deflection. This motion of ballistic control should take about 1/4 second. Return ballistic control immediately after reading meter to rest position. Microammeter should read the same at

beginning and end of deflection within 1 or 2 divisions. If deflection is greater than this, see note on step 19 for directions for ballistic control adjustment.

Also, in future directions where ballistic vane readings are made, immediately after reading the meter the vane is returned to its rest position.

20. Check on U metal Standard.

Place brass holder containing U metal standard on end of ion chamber with U metal in direct contact with chamber end. Release chamber ground and lock in raised position at the same time that an interval timer such as a stop watch is started.

Near end of 30 second time interval, note meter reading. At end of 30-second time interval, again turn ballistic control to right and note highest swing of meter. The difference between the net ballistic swing of the meter and the net reading found in step 19 is the net ballistic deflection. It should equal the meter deflection for one U unit as given in the vane method meter conversion chart.

An example of this type of reading follows.

Meter reading as of step 19, vane in rest position	0.0
Maximum meter reading on turning vane to right	1.1
Net meter deflection <u>a</u>	$1.1 - 0.0 = 1.1$
Meter reading, with U standard in place, near end of 30-second interval of step 20	0.3
Maximum meter reading on turning ballistic control to right	17.2
Net meter deflection <u>d</u>	$17.2 - 0.3 = 16.9$
Net ballistic deflection of U standard, difference of first and second net readings, <u>a</u> - <u>b</u>	$= 16.9 - 1.1 = 15.8$

Some operators find it more convenient to adjust to 2 or 5, rather than to zero of microammeter. The operating procedure is otherwise as has been outlined.

21. Ground chamber by depressing and locking chamber ground. This should always be done immediately on completion of a vane reading. Check test 1 and test 2 positions, making any necessary adjustments of control 1 and control 2. Instrument is now ready for operation.

#### Ballistic Vane Measurements of Hard Beta Radiation, Medium and High Intensity

22. Outside strong radiation field, release chamber ground and lock in raised position. Read meter. Turn ballistic control to right and take maximal meter deflection. This value minus the rest reading above is the net meter deflection of step 22. Reground chamber.

23. With instrument in position where measurement is to be made, release chamber ground key, immediately starting interval timer such as stop watch.

24. At end of 30 seconds, turn ballistic control to right, noting initial and maximal meter reading. Subtract from the difference of these readings the net reading of step 22. The resultant figure may now be converted to beta-ray intensity by means of the vane method beta-ray conversion chart.

If more than a full-scale meter deflection is obtained at this time, the procedure may be repeated shortening the ion collection time: that is, the period between releasing the chamber ground and turning the ballistic control to 15 or 10 seconds. The indicated gamma-ray intensity, as indicated by the beta-ray conversion chart, must be multiplied by 2 or 3, respectively, to give the true result.

25. If net reading on meter was 5 or more, ground key may be locked in position and meter taken to location of next reading. If net reading was less than 5 and it is desirable to know the beta-ray intensity accurately, it may be advisable to make another reading at the end of an additional 30-second period. If the chamber has not been regrounded, this reading will be cumulative for the one-minute period. If the total collection time is one minute, the net reading in U units, indicated by the calibration chart will be divided by two to give the correct beta-ray intensity. If the ion collection time is 90 seconds, the

indicated reading should be divided by 3: if 2 minutes, by 4, etc.

#### Ballistic Measurements of Hard Beta Radiation, Low Intensity

26. More accurate values for low intensities of beta radiation can be obtained if a slightly modified method of making readings is carried out as follows:

a) Release and lock grounding key in raised position. Read meter, turn ballistic control to right and read maximal meter deflection. Start stop watch as ballistic control is turned. Subtract to obtain net meter deflection of step a.

b) At the end of one or more minutes turn ballistic control again to right, noting initial and maximal meter readings. Subtract to obtain net meter deflection of step b.

c) Subtract the net meter deflection of step a from step b. Convert this result to U units by the use of the vane method beta-ray conversion chart. This result must now be divided by 2 for one minute, by 4 for 2 minutes, etc., to give the true intensity.

#### Ballistic Measurement of Gamma Radiation

27. Gamma-ray measurements are made with the Lucite beta-ray shield in place on end of chamber to prevent the entrance of beta radiation. Operating instructions are essentially the same as for beta-ray measurements. If instrument is not already on, turn on and check beta sensitivity as described in steps 15 through 20. Then place beta-ray shield on end of chamber.

28. Place meter chamber in position where gamma-ray intensity measurement is desired. In strong gamma-ray fields there will be a slight upward drift of meter due to ionization inside instrument case. For maximum reproducibility of measurement, wait until meter is relatively steady.

a) Release chamber ground key. Immediately turn ballistic control to right. Record initial and maximal reading. The difference between these readings is the net step a reading.

b) Reground ionization chamber. Release ground key and lock in raised position, at same time starting stop watch. Record meter reading. At end of 30 second period, turn vane to right. Read maximal meter deflection. From this reading subtract reading made before vane was deflected. This is the net step b reading.

29. Subtract from net step b reading net step a reading. This is the net ballistic reading. From vane method gamma-ray conversion chart read gamma r per 8 hour day.

30. If this final reading is greater than 5, reground chamber. If reading is less than 5 and a precise determination is desired, the vane deflection may be repeated at the end of an additional 30 seconds, the indicated conversion chart reading being divided by 2 for the correct result.

#### Measurement of Radioactivity Collected in Dust Precipitron Tubes

31. Replace Lucite chamber with precipitron tube chamber. This is done by unscrewing Lucite chamber at base and screwing in dust tube chamber. The dust tube chamber cap should be placed on the Lucite chamber. This change should be made, if possible, in a dust free area of low humidity.

If unit is used in an area of relatively low humidity the outer shell may first be removed by taking out studs labeled A in dust chamber diagram.

If unit is used in an area of high humidity this outer chamber may be left on, and after the insertion of a precipitron tube, the chamber roughly evacuated by a vacuum pump or water suction through the tube in the cover and air admitted through a calcium chloride drying tube.

In changing precipitron tubes, care should be taken not to touch both precipitron tube and meter case or outer brass shell at the same time. This shorts the ion collection voltage through the body. The current is too small to produce any noticeable sensation. If meter is operating, however, the

microammeter will deflect to left. One should wait until microammeter is again not drifting, before starting measurements.

32. Turn on meter for ballistic vane measurements as directed in steps one through 10 and 15 through 18.

33. Preparation of calibration curve. Because of the varying types of material for which this unit may be used no calibration curve is included with the instrument. Data for preparing a calibration curve is given in appendix as note on step 33.

34. With chamber ground key locked in depressed position, insert precipitron tube.

35. With microammeter steady, release ground key and lock in raised position. Immediately turn ballistic vane control to right, starting interval timer as vane is turned. Record initial and maximal meter reading.

36. At one minute intervals thereafter record meter reading, turn ballistic control to right and record maximal meter reading.

Data may be recorded in the following form:

Time	Vane in	Vane out	Net	Net increase per minute
0	2.0	2.2	.2	2.0
1	2.0	4.2	2.2	2.0
2	2.0	6.2	4.2	2.0
3	2.0	8.4	6.4	2.2
4	2.0	10.6	8.6	2.2
5	1.9	12.7	10.8	2.2

37. Subtract the first net reading from the last. From the calibration curve read corresponding amount of alpha active material.

If ion collection time was five minutes, this is the correct result.

If alpha collection time was different from 5 minutes, the result is multiplied by (5/ion collection time in minutes), to give correct value.

Results of column headed "net increase per minute" are not used in the final calculations. However, all figures in this column should be close together. It provides a useful check on operation of meter. If values in this column differ widely, the data should be disregarded and readings repeated.

#### Measurement of Alpha Surface Activity

38. Replace Lucite chamber with alpha surface monitoring chamber. This chamber also has provided with it an extra support attached by thumb screws for hand monitoring. Because of the different alpha activities of varying materials, no calibration curve has been provided. A ballistic vane calibration curve can be prepared as directed under the note on step 33. A direct reading curve can be prepared using known sample activities. If only one sample is available, no large errors are introduced by considering the instrument response as linear. 350 alphas per minute, as measured on a counter with 50% geometry, give approximately a one microampere per minute increase in ballistic vane readings.

39. Operating instructions are the same as those for beta activities given in steps 1 through 26, with this exception. The outside of the chamber base is at the ion collection potential, and therefore, care should be taken, particularly in hand monitoring, that one does not touch the ion chamber base and the unit proper at the same time. There is no shock, due to the low current involved, but a spurious meter deflection is produced.

### Measurement of Neutrons with Hydrogen-Filled Pressure Chamber

This chamber has a paraffin lining and is filled with hydrogen to a pressure of \_\_\_\_ pounds at 23° centigrade.

Compared with a Victoreen 100 r chamber and also with the Lucite chamber furnished with this instrument, it has about a fivefold increased sensitivity to fast neutrons as opposed to its response to gamma radiation. Its response to slow and thermal neutrons has not been determined.

The calibration curves provided give its gamma sensitivity and also its neutron sensitivity as calibrated with the Rochester cyclotron as a neutron source.

With its increased neutron sensitivity the readings found with an unknown mixture of fast neutrons and gamma radiation are reasonably proportional to biological effectiveness of these radiations.

A calibration curve in terms of tolerance dosage of these radiations is also provided, based on the assumption that the permissible gamma dosage is 0.1 r per day. If the beam should be pure fast neutrons similar in composition to that available at Rochester, the curve will be essentially correct. If the beam were pure radium gamma radiation with two millimeters of platinum equivalent filtration, the dosage will be over estimated by a factor of 2.

A more complete report on the characteristics of this chamber is being prepared.

40. Operation instructions are the same as those given for gamma measurements with the Lucite chamber in steps 14 and 27 through 30.

41. If this chamber is filled with argon to a pressure of 200 pounds above atmospheric, its gamma sensitivity is about 8 times that of the Lucite gamma chamber. With this chamber, an intensity of 0.0006 r per 8 hours will give an increase in ballistic vane reading of about one microampere per minute, an easily made reading.

### Battery Renewal

42. Access to battery box is obtained by removing bottom plate of instrument. The batteries used are: for tube filament, two BA-15A connected in parallel; for B supply, one BA-2; for chamber voltage two BA-56 connected in series. When the meter can no longer be adjusted to 40 on test 1 position, the filament batteries need replacing. When adjustment on test 2 position is no longer possible, the B battery needs replacing. No current is drawn from the two chamber 45 volt batteries and should have shelf life. Their voltage should be occasionally checked with a voltmeter.

### Notes on Operating Instructions

Note on Step 1: The direct reading switch and chamber ground switch are the two aluminum knobs at the front of the meter. With the meter in normal position, they move up and down and are locked in these two positions by a short turning motion. The chamber collecting electrode is grounded when the chamber ground is depressed. For use of the direct reading method, the direct reading switch is locked in the raised position. For use of the ballistic method, it is locked in the depressed position.

Note on Step 2: The aluminum vane stop knob will lock by turning in the raised position. To set the ballistic control for direct reading, lock this vane stop in the raised position, turn the ballistic control knob to the right as far as it will go easily, and then unlock and depress the vane stop knob. This puts the ballistic control in the proper position for steady deflection measurements. Force must never be applied to the ballistic control, nor should one attempt to operate it when the vane stop is even partially depressed. One should not attempt to depress the vane stop knob, except when the ballistic control is turned to the extreme right.

Note on Step 4: This operation sets the filament emission of the electrometer tube at the correct value.

Note on Step 5: This operation sets the other potentials applied to the electrometer tube at their correct values.

Note on Step 8: This operation changes by a fixed amount the control grid bias of the electrometer tube. It is, therefore, a check on circuit sensitivity. By means of a screw driver adjustment, of the sensitivity control beneath the handle, the meter may be adjusted to read 40 if for any reason the circuit sensitivity has changed.

Note on Step 9: If care has been taken not to disturb the zero adjustment, the meter can be kept at zero by adjusting the meter to read 40 on test 1 and test 2 positions.

Note on Step 15: This instrument has been primarily designed for the ballistic vane method of operation, and this will probably be most commonly used. With the intensities of radiation of importance in monitoring for medical purposes, readings using this method can usually be made every minute. It will be found that, with a little practice, most of the pertinent data can be computed mentally, with the aid of the conversion tables, so that only the final results need be recorded.

Note on Step 17: For precautions to take in operation of vane and vane stop; see note on step 2.

Note on Step 18: A time interval of about two minutes should intervene between steps 17 and 18.

Note on Step 19: If on turning ballistic vane control to the right, maximum meter reading is either to the left or more than two divisions to the right of the resting reading, proceed as follows: (1) Note maximum meter reading. (2) With ballistic control in rest position, adjust with screw driver the deflection adjustment under handle so that the meter reads the same as the final maximum ballistic deflection. Meter will slowly return to original reading. The spurious deflection on turning the ballistic control should now be diminished as absent. If necessary, this adjustment may be repeated.

If instrument case has been opened, or if instrument has been subjected to violent mechanical shock, electrostatic charges may be built up on internal insulators that will produce violent and erratic meter deflection on operating the ballistic control. These will disappear spontaneously in a few days. They may also be removed by setting the whole instrument in a strongly ionizing field. For example, this condition may be remedied by placing a milligram radium needle for 10 minutes on the instrument case. The direct reading and chamber ground switch should be locked in depressed position for this procedure.

If ballistic control is turned right, with the chamber switch depressed in ground position, the meter will in general not take the same position as with the chamber ungrounded. Care must be taken, therefore, that the ground switch is raised before taking a so-called "zero reading."

Note on Step 33. Preparation of Calibration Curve: A precipitron tube should be prepared with a known amount of the radioactive substance that it is desired to measure distributed as uniformly as possible over the inner wall. An amount giving 600 to 800 alpha disintegrations per minute is the correct order of radiation intensity. With ground key locked in depressed position, place tube in socket of instrument.

The following directions essentially duplicate those for ballistic vane beta-ray measurements:

- a) Record microammeter reading.
- b) Release ground switch and lock in raised position. Immediately turn ballistic control to right, at the same time starting stop watch. Record maximal meter deflection; return to rest position.
- c) Toward the end of a one minute period read meter and again turn vane to right, recording maximal meter deflection.
- d) Repeat this procedure at one minute intervals until full scale deflection is reached.

This data may be recorded somewhat as follows:

Ion collection time	Vane in	Vane out	Net vane reading	Net increase in vane deflection
0	2.1	2.7	.6	
1	2.1	5.9	3.8	3.2
2	2.1	8.9	6.8	6.2
3	2.1	12.4	10.3	9.7
4	2.1	15.9	13.8	13.2
5	2.0	19.3	17.3	16.7

The net increase in vane deflection is obtained by subtracting the first net vane reading from the others.

With this instrument operating by the ballistic method, the net increase in vane reading for any collection period is directly proportional to the intensity of radiation and also to the time duration of the collecting period. This reciprocity relationship is used to obtain a calibration curve.

The calibration curve is obtained by plotting the net increase in vane deflection for a five minute period of ion collection to amount of radioactivity in dust tube. This may be done in the following manner: Let Q equal the amount of material in the standard tube. Substitute in the foregoing table for the figures under ion collection time, Q/5 multiplied by the actual ion collection time in minutes, and re-labelled this column, amount of radioactive material in dust tube. The figures under net increase in vane deflection now give the net increase in vane deflection for a five-minute ion collection time corresponding to the amount of radioactive material in the dust tube.

An example of this calculation, using the data given, and assuming Q equals 500 micrograms U metal follows:

Amount of radioactive material in dust tube (micrograms U)	Net increase in vane deflection for five minutes ion collection time
100	3.2
200	6.2
300	9.7
400	13.2
500	16.7

The final curve is obtained by plotting this data as given in the example shown in Figure 1.

#### Notes on Servicing

Figure 2 shows the wiring details of the circuit. Figure 3 shows the placing of important electrical components. Figures 5, 6, and 7 show internal construction of the alpha surface monitor, the hydrogen-filled, paraffin-lined chamber for neutron measurements, and the chamber for precipitron dust tube measurements, respectively.

**Battery renewal:** Access to the battery compartment is obtained by removing the base. Step 42 gives directions on battery renewal. The ion collection voltage may be checked without the necessity of removing the base by unscrewing the ion chamber and measuring from the outer spring chamber contact to ground. A 100,000 ohm resistor is in series with this contact so that a high resistance meter such as the Volt Ohmyst Junior is needed for measurements at this point.

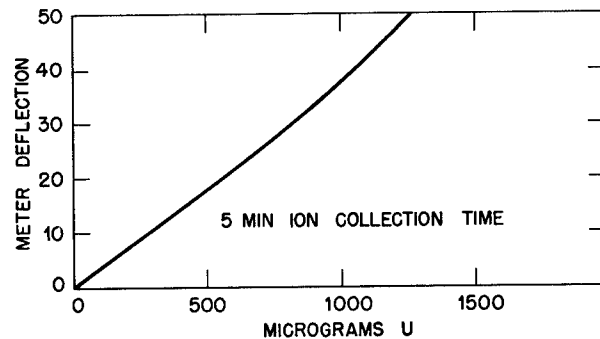

Figure 1 Calibration curve.

### Circuit

The circuit utilizing a standard 1LN5 tube manufactured by National Union is shown in Figure 2. All resistance values are given in ohms. Approximate values to which adjustable resistors are set are shown in brackets. 80% of the tubes of this manufacturer are found satisfactory. Figure 4 shows the characteristics of an average tube (median as regards control grid current of a group of 21 investigated). The suppressor grid is used as control grid in this application.

Operating voltages of the tube in this unit number \_\_\_\_\_ have been adjusted relative to the negative filament lead as follows:

PLATE, \_\_\_\_\_  
 Suppressor grid (used as control) measured at S3  
 OPERATE POSITION, \_\_\_\_\_ volts  
 SENSITIVITY TEST POSITION, \_\_\_\_\_ volts  
 SCREEN GRID, \_\_\_\_\_ volts  
 NORMAL CONTROL GRID, \_\_\_\_\_ volts

The filament voltage is approximately one volt. P8 is adjusted so that in test one position 250 microamperes screen current gives a meter deflection of 40.

A two pole, triple throw switch allows the output meter to be connected in test 1 position to measure screen grid current, in test 2 position to measure tube voltages, and in "Operate" position to measure changes in plate current. All circuit components are standard manufactured items except the condenser and switches S1 and S2. All resistors except R1, R2, R3, R9, and R10 are adjustable wire wound. In placing unit in operating condition, adjustments were so made that on test 1 and test 2 positions with proper tube voltages and currents the meter reads 40.

Adjustment of R4 makes it possible to bring all instruments of this type to approximately the same calibration.

Access to Circuit: After removing the four machine screws on each side of the upper front half of the instrument, the circuit and ion chamber will slide forward and can be removed from the remainder of unit and the circuit made accessible for servicing. In some units the top has been sealed with paraffin. Gentle warmth will break this bond. On reassembling, a dust and moisture proof bond should be re-established.

Drying: The circuit box contains two screen top boxes filled with eight mesh "Drierite", blue in a desiccated condition, turning pink on absorbing moisture. If these chambers are refilled, care should be taken that all granules are large enough not to pass through the screen tops of the boxes.

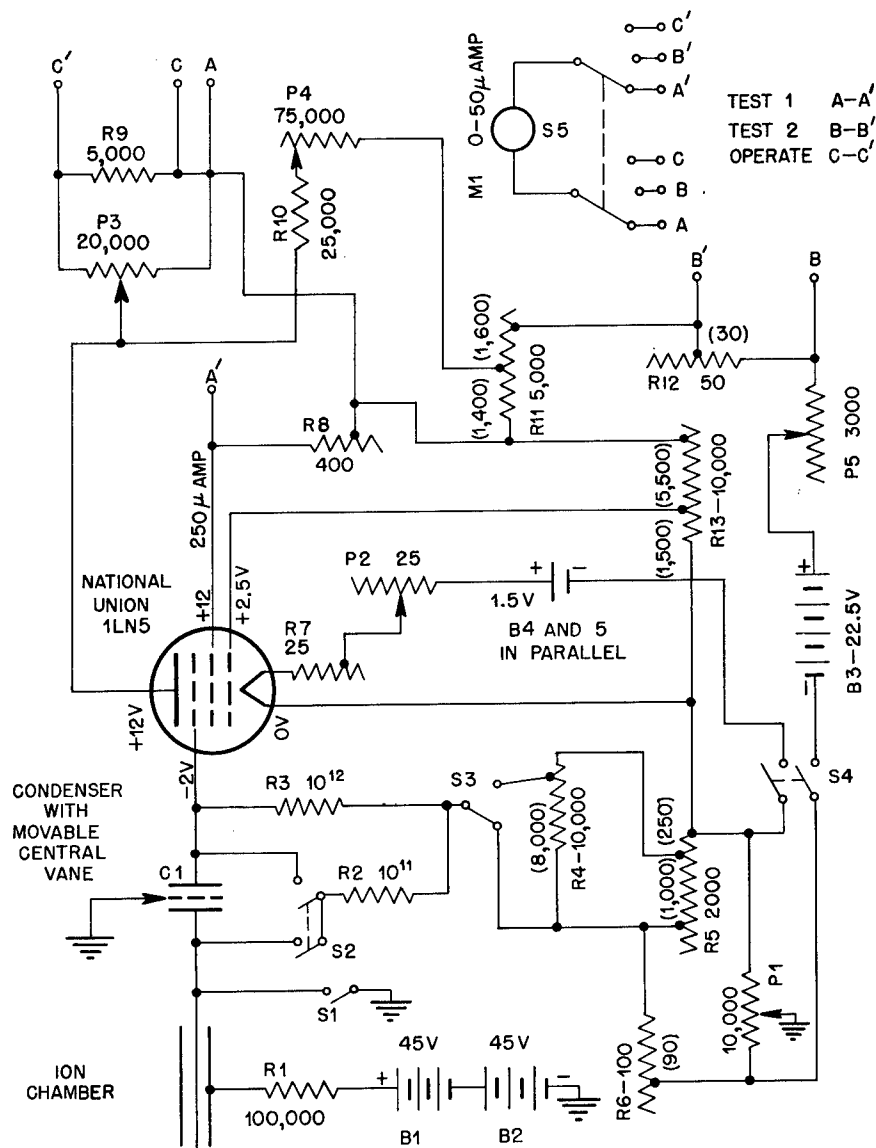

Figure 2. Rochester ion meter circuit, model two.

**Insulation of Circuit Box:** It is necessary that control grid parts of the circuit be very highly insulated in order for the unit to perform properly. All of these parts are made of Lucite except the tube base which is polystyrene. If any of these insulating parts are touched or otherwise made dirty, they should be cleaned, the Lucite with ether, the polystyrene tube base with absolute alcohol.

**Electrical Charges on Insulators:** Almost certainly on opening the circuit box, inevitable on touching or cleaning Lucite parts, and occasionally for other reasons, predominantly mechanical shocks, electrostatic charges will appear on insulators giving very erratic performance of the ballistic control. These effects may be very startling, the slightest motion of the ballistic control giving full scale meter deflections.

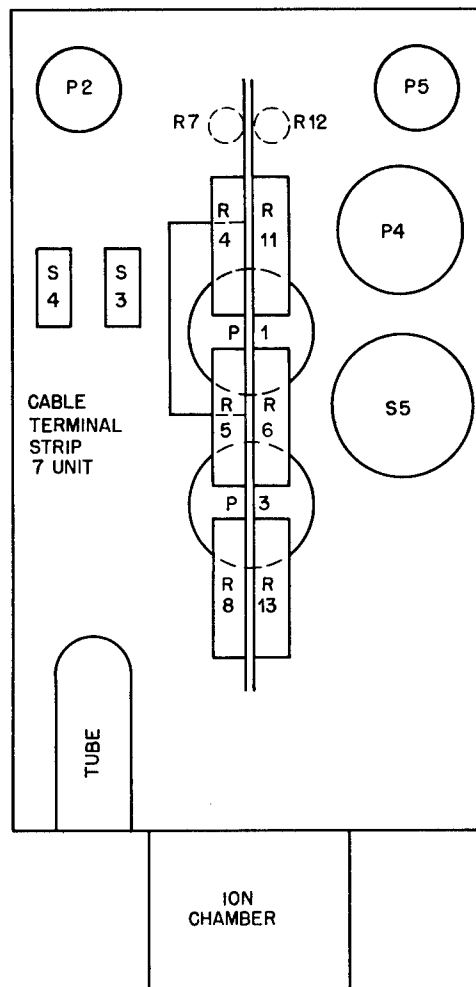

Figure 3. View showing position of wire wound resistors and potentiometers from below.

This effect is removed by placing the instrument in a strongly ionizing radiation field, for example, by placing a two milligram radium needle beside the microammeter for ten minutes.

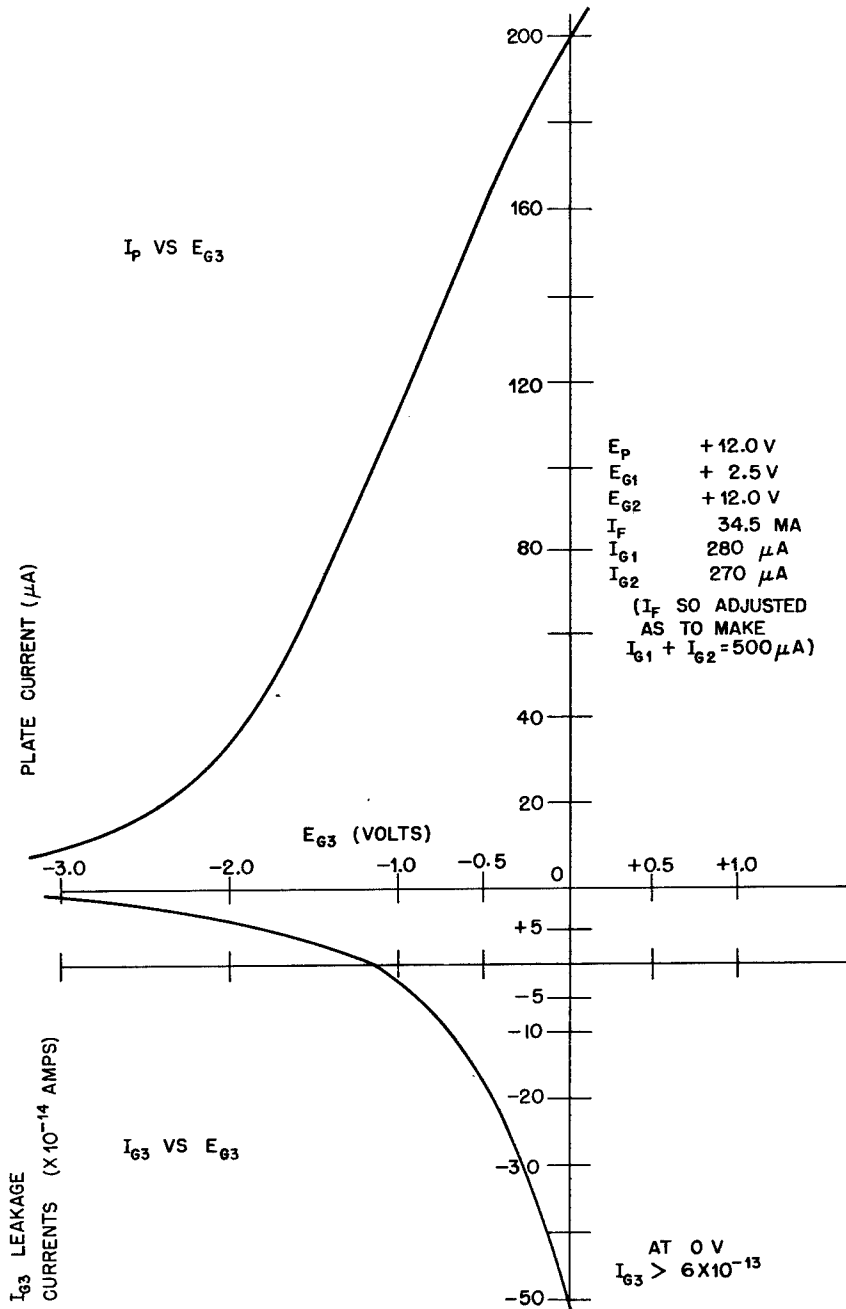

Figure 4. 1LN5 tube. Identification No. 10 grid No. 3 used as control grid.

If the unit is serviced care should be taken that insulators with motion do not touch any other parts, for if they do, such electrical charges can accumulate during operation of the instrument. Particularly,

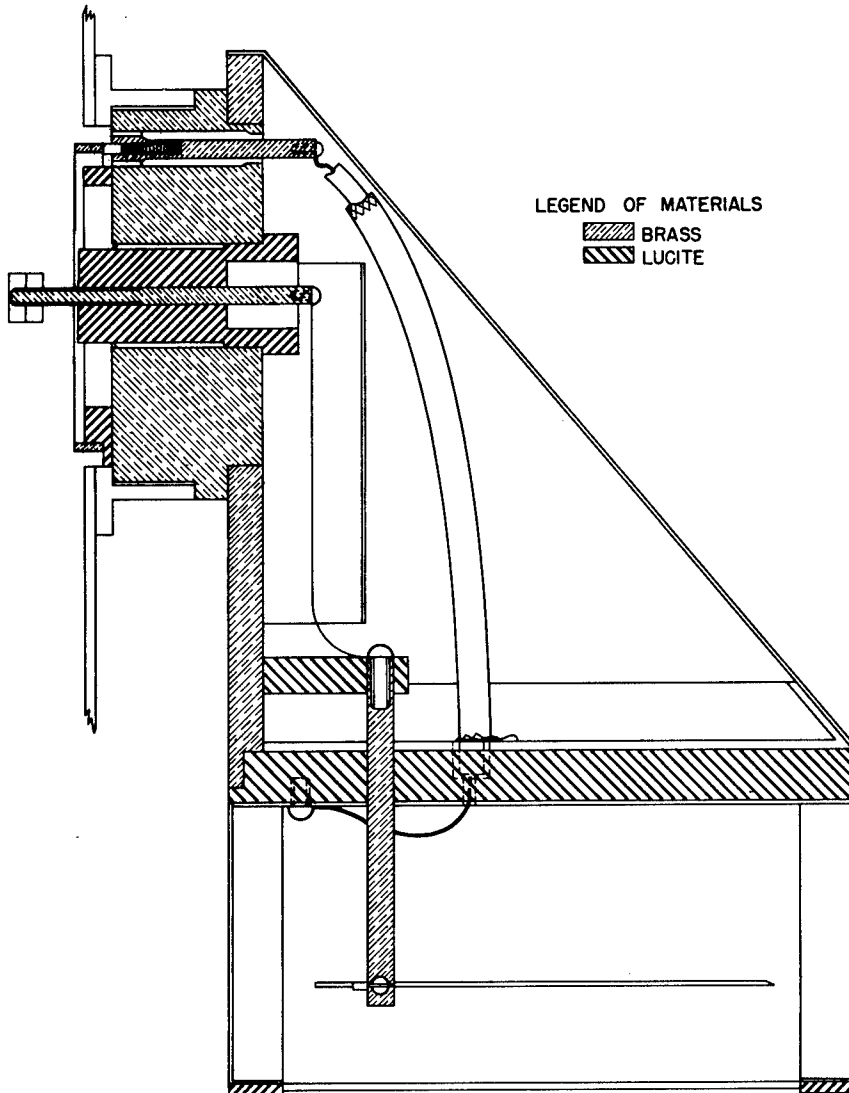

Figure 5a. Alpha surface monitor.



Figure 5b. Hand monitoring support.

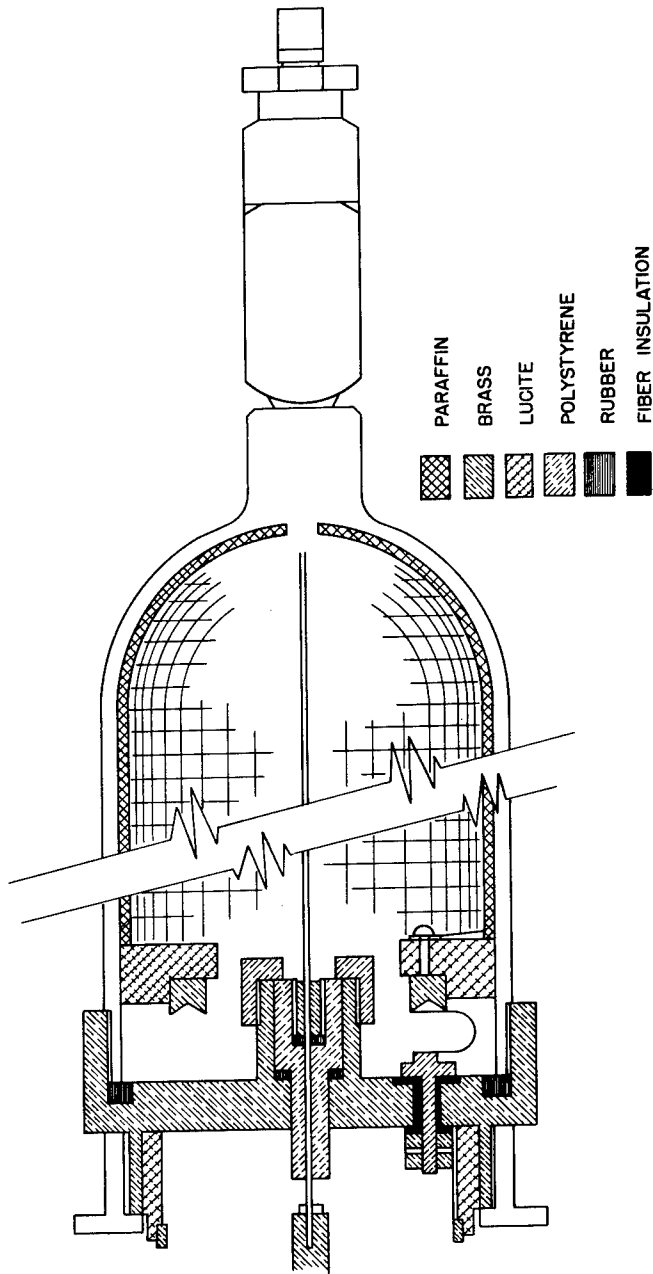

Figure 6. Neutron chamber.

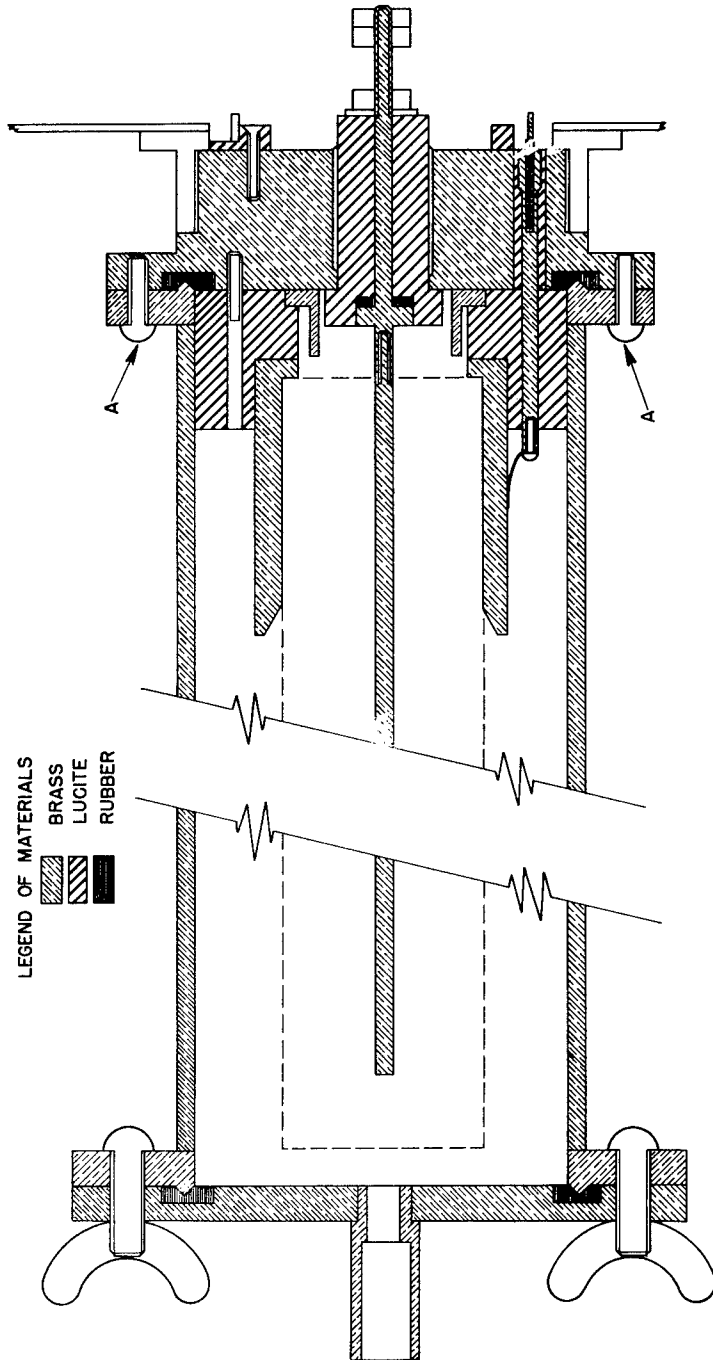

Figure 7. Auxiliary chamber for dust measurements.

care should be taken that the lead from C1 to the 1LN5 does not touch anything and is self-supported, that the flexible lead from R2 to S3 does not make any mechanical contacts during the motion of S3, and that the microammeter leads are short, direct, and do not come close to the condenser plates.

**Use of Deflection Adjustment:** See note on step 19. If the potential of C1 connected to the acting control grid of the tube is not the same as the potential of the grounded movable ballistic vane, meter deflection will occur on moving ballistic control even though there is no charge on the chamber central electrode and no charges present on insulators. The deflection adjustment is an adjustable circuit ground for abolishing this effect. Almost certainly, inability to remove this type of deflection by the procedure of the note on step 19 indicates the presence of electrostatic charges to be removed by a radiation field.

As mentioned in step 19, due to contact potential differences, deflection adjustment changes should be made with chamber ungrounded; i. e., locked in raised position. However, chamber should be momentarily grounded between those adjustments.

**Replacement of microammeter:** If the microammeter should be replaced, it will almost certainly be necessary to readjust R8 and R12. Also if its critical damping resistance differs appreciably from the meter originally supplied, R9 or P3 may need replacing since a too rapidly moving meter makes readings difficult and inaccurate while an unnecessarily low resistance in parallel with the meter may seriously reduce sensitivity.

**Service of Lucite Ionization Chamber:** The control insulator of the Lucite ionization chamber may be removed by unscrewing. It is made of Lucite and may be cleaned by not more than one minute's contact with ether. This differs from the unit described in the construction manual where it is press-fitted polystyrene.

The outer brass ring at the base carries the ion collection voltage to the chamber. The inner ring is the guard ring operating at ground potential. The resistance between them should be infinite by ordinary measurements.

The inside of the ionization chamber is coated with aquadag. Lack of electrical contact between the base ring and the aquadag coating or between the chamber and screw-on cap is indicated by a sensitivity of the unit to touching the chamber with the ballistic control locked in the right hand position. A wetting agent should be added to the aquadag used in making any chamber repairs. Care must be taken that aquadag does not cross the Lucite spacer to the guard ring. Also aquadag must not provide a conducting path to the outside of the chamber.

**Leakage Tests:** The unit for maximum accuracy ought to be able to hold a charge without appreciable leakage for many minutes. This may be tested in the following manner. Check U metal standard as described in step 20 with the following modification. At end of one minute period, remove U standard before moving ballistic control. Without grounding make ballistic vane readings for the next five or ten minutes, recording data as shown in note on step 33. In the absence of radiation the net vane reading should not decrease by more than one microampere in ten minutes. Leakage shown by constantly decreasing net vane readings indicates necessity for cleaning either chamber or basic unit.

Similar tests using appropriate radiation sources may be carried out for other chambers.

**Alpha Surface Monitor Service:** By removing four Lucite screw-in feet in the base, the screen may be removed for decontamination. The insulators in this unit are all Lucite and may be cleaned with ether. One may test for electrical leakage with any alpha source using methods given for the Lucite chamber.

**Servicing chamber for dust measurements:** All insulators in this unit are Lucite and may be cleaned with ether. The socket holding the dust tube may be removed by taking out two set screws for easier cleaning of the Lucite central insulator. The chamber voltage lead-in has been sealed in place with paraffin to render the unit vacuum tight. It may be removed by gently warming. In replacing the paraffin, care should be taken not to condense moisture from a direct flame shorting out the electrical insulation in this area.

A charge for leakage tests may be conveniently put on the central electrode by holding an alpha source at the open end of the tube.

The unit should preferably be used in a horizontal position so that dust will not drop in the socket.

**Servicing Neutron Chamber:** The central electrode of this unit is polystyrene and should be cleaned with absolute alcohol. If the chamber is refilled with hydrogen, the air should be first evacuated.

**Note on Constancy of Calibration:** If the Lucite chamber maintains its calibration as shown by use of the beta standard, then other chambers should keep their original calibration provided there is no electrical leakage or leakage of gas from the neutron chamber.

END OF DOCUMENT