

NAVAL POSTGRADUATE SCHOOL
Monterey, California



THESIS

**DETERMINING AN OPTIMAL BULK-CARGO SCHEDULE
TO SATISFY GLOBAL U.S. MILITARY FUEL
REQUIREMENTS**

by

Jorge E. Quiroga
Jason T. Strength

September 1996

Thesis Advisor:

Dan Boger

Approved for public release; distribution is unlimited.

19970129 052

DTIC QUALITY INSPECTED 4

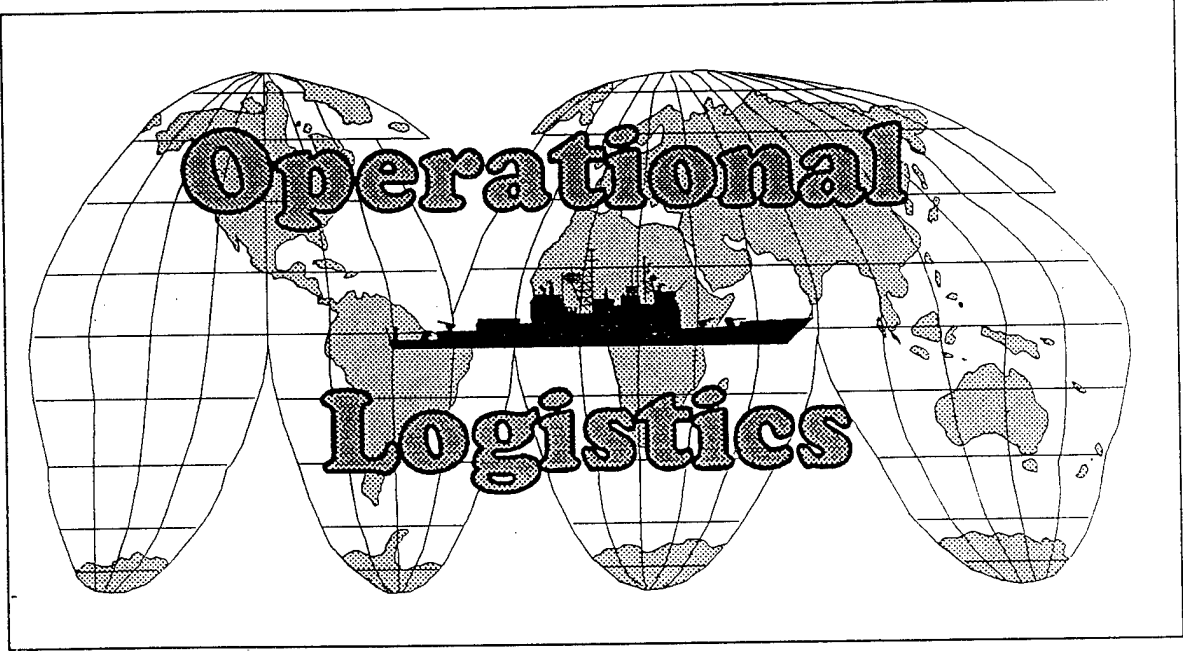

REPORT DOCUMENTATION PAGE			Form approved OMB No. 0704-188	
Public reporting burden for this collection of information is estimated to average 1 hour per response, including the time for reviewing instructions, searching existing data sources, gathering and maintaining the data needed, and completing and reviewing the collection of information. Send comments regarding this burden estimate or any other aspect of this collection of information including suggestions for reducing this burden, to Washington Headquarters services, Directorate for Information Operations and Reports, 1215 Jefferson Davis Highway, Suite 1204, Arlington, VA 22202-4302, and to the Office of Management and Budget, Paperwork Reduction Project (0704-0188), Washington, DC 20503.				
1. AGENCY USE ONLY (Leave Blank)		2. REPORT DATE September 1996	3. REPORT TYPE AND DATES COVERED Master's Thesis	
4. TITLE AND SUBTITLE DETERMINING AN OPTIMAL BULK-CARGO SCHEDULE TO SATISFY GLOBAL U.S. MILITARY FUEL REQUIREMENTS			5. FUNDING NUMBERS	
6. AUTHOR(S) Quiroga, Jorge E. Strength, Jason T.				
7. PERFORMING ORGANIZATION NAME(S) AND ADDRESS(ES) Naval Postgraduate School Monterey, CA 93943-5000			8. PERFORMING ORGANIZATION REPORT NUMBER	
9. SPONSORING/MONITORING AGENCY NAME(S) AND ADDRESS(ES)			10. SPONSORING/MONITORING AGENCY REPORT NUMBER	
11. SUPPLEMENTARY NOTES The views expressed in this thesis are those of the author and do not reflect the official policy or position of the Department of Defense or the U.S. Government.				
12a. DISTRIBUTION/AVAILABILITY STATEMENT Approved for public release; distribution is unlimited.			12b. DISTRIBUTION CODE	
13. ABSTRACT (Maximum 200 words) The Defense Fuel Supply Center (DFSC) is responsible for the acquisition, storage, and distribution of bulk petroleum products to support worldwide military service requirements. DFSC delivers these fuel products around the globe through a fleet of bulk-cargo tankers which are controlled by Military Sealift Command (MSC). The current method of scheduling cargo deliveries is done manually and takes approximately three to five days to complete, requiring close interaction with MSC. The cargo scheduling planners must specify a feasible load port and time, and discharge port and time for each cargo such that military fuel demands are met and the tankers are utilized efficiently. Currently, there are no mathematical models available to assist scheduling planners in assigning an efficient cargo schedule. The objective of this thesis is to aid scheduling planners in determining the most efficient cargo sequencing plan. This is achieved through the development of a mathematical model which represents the cargo scheduling problem, and the design of a microcomputer interface. Specifically, an optimization model utilizing the network structure of the maximum flow model, accessible through a spreadsheet-based interface, is used to solve the cargo scheduling problem by maximizing the number of cargo deliveries.				
14. SUBJECT TERMS Integer Programming, Optimization, Network Flow, Scheduling, Bulk Tanker, Petroleum			15. NUMBER OF PAGES 89	
			16. PRICE CODE	
17. SECURITY CLASSIFICATION OF REPORT Unclassified	18. SECURITY CLASSIFICATION OF THIS PAGE Unclassified	19. SECURITY CLASSIFICATION OF THIS ABSTRACT Unclassified	20. LIMITATION OF ABSTRACT UL	

Approved for public release; distribution is unlimited

**DETERMINING AN OPTIMAL BULK-CARGO SCHEDULE TO SATISFY
GLOBAL U.S. MILITARY FUEL REQUIREMENTS**

Jorge E. Quiroga
Lieutenant, United States Navy
B.S., San Jose State University, 1988

Jason T. Strength
Lieutenant, United States Navy
B.S., Georgia Institute of Technology, 1990

Submitted in partial fulfillment of the
requirements for the degree of

MASTER OF SCIENCE IN OPERATIONS RESEARCH

from the

**NAVAL POSTGRADUATE SCHOOL
September, 1996**

Authors:

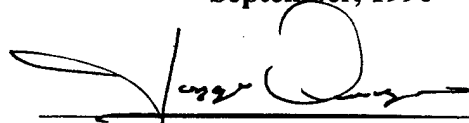

Jorge E. Quiroga

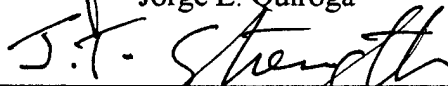

Jason T. Strength

Approved by:

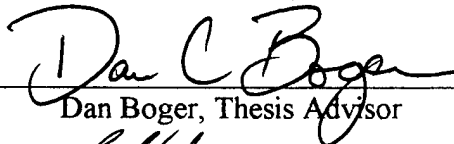

Dan Boger, Thesis Advisor



Bob Vassian, Second Reader

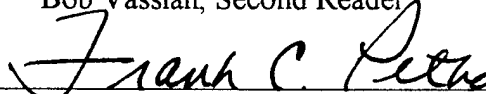

Frank C. Petho, Chairman
Department of Operations Research

ABSTRACT

The Defense Fuel Supply Center (DFSC) is responsible for the acquisition, storage, and distribution of bulk petroleum products to support worldwide military service requirements. DFSC delivers these fuel products around the globe through a fleet of bulk-cargo tankers which are controlled by Military Sealift Command (MSC). The current method of scheduling cargo deliveries is done manually and takes approximately three to five days to complete, requiring close interaction with MSC. The cargo scheduling planners must specify a feasible load port and time, and discharge port and time for each cargo such that military fuel demands are met and the tankers are utilized efficiently. Currently, there are no mathematical models available to assist scheduling planners in assigning an efficient cargo schedule.

The objective of this thesis is to aid scheduling planners in determining the most efficient cargo sequencing plan. This is achieved through the development of a mathematical model which represents the cargo scheduling problem and through the design of a microcomputer interface that allows use of the model as a management tool which seeks to maximize the number of cargo deliveries. Specifically, an optimization model utilizing the network structure of the maximum flow model, which is accessed through a spreadsheet-based interface, is used to solve the cargo scheduling problem.

DISCLAIMER

The views expressed in this thesis are those of the authors and do not reflect the official policy or position of the Department of Defense or the U.S. government.

Additionally, the reader is cautioned that computer programs developed in this research may not have been exercised for all cases of interest. While every effort has been made, within the time available, to ensure that the programs are free of computational and logical errors, they cannot be considered validated. Any application of these programs without additional verification is at the risk of the user.

TABLE OF CONTENTS

I. INTRODUCTION	1
II. CURRENT OPERATIONS AT DFSC	5
A. SLATE	6
B. SOURCE CONTRACTS	7
C. CONTROLLED FLEET	8
III. CARGO SCHEDULING MODEL	11
A. NETWORK STRUCTURE	11
B. MODEL ASSUMPTIONS	16
C. MATHEMATICAL FORMULATION	18
D. RELATED WORK	21
IV. IMPLEMENTATION AND APPLICATIONS	25
A. PROGRAM INTERFACE	25
B. SAMPLE PROBLEM	27
C. APPLICATIONS	32

V. CONCLUSION	35
A. SUMMARY	35
B. AREAS FOR FURTHER RESEARCH	36
APPENDIX A. GAMS SOURCE CODE	39
APPENDIX B. USER'S GUIDE	43
APPENDIX C. VISUAL BASIC SOURCE CODE	55
LIST OF REFERENCES	73
INITIAL DISTRIBUTION LIST	75

EXECUTIVE SUMMARY

The Defense Fuel Supply Center (DFSC) is one of five inventory control points in the Defense Logistics Agency (DLA). As the petroleum materiel manager, DFSC is responsible for the acquisition, storage, and distribution of fuel to support the military services and over 4000 federal agencies. With a \$4.4 billion annual budget, DFSC procures, stores, and distributes over 148 million barrels of petroleum products annually. For the U.S. military, three types of fuel account for approximately 98% of the total fuel supply, including: JP-5, a kerosene-based jet fuel primarily used for U.S. Navy carrier based aircraft; JP-8, a kerosene-based jet fuel, similar to Jet A-1, primarily used by the Air Force; and F-76, U.S. naval diesel fuel which is similar to marine gasoil.

DFSC delivers fuel products by truck, rail, pipeline, barge, and a fleet of bulk-cargo tankers which are controlled by Military Sealift Command (MSC). Of these delivery methods, MSC controlled tankers typically deliver less than 35% of the total volume of fuel (measured in barrels), yet are responsible for over 65% of the total transportation costs, requiring an annual budget of over \$240 million. Therefore, efficient cargo scheduling and tanker routing is an attractive candidate for cost reductions.

The current method of scheduling tankers is done manually utilizing a poster-board that is drafted to represent a spreadsheet, a calculator, and corporate knowledge as decision tools. Cargo schedulers must consider, at a minimum, cargo type, cargo availability, cargo quantity, time constraints, load ports, discharge ports, load and discharge times, distance between ports, tanker capacity, tanker speed, tanker location,

and tanker availability. The important decisions required by the scheduler are to specify a feasible load port and time, and discharge port and time for each cargo such that the fuel demand is met and the tanker is utilized efficiently. Each schedule takes approximately three to five days to complete and requires close interaction with MSC. The workload does not permit manual generation and analysis of all potential schedules, thus the resulting schedule may not be efficient. Currently, there are no automated decision tools available which allow scheduling planners to assign cargo schedules quickly and efficiently.

The objective of this thesis is to aid scheduling planners in determining the most efficient cargo sequencing plan. This objective will be achieved through the development of a mathematical model to represent the cargo scheduling problem and the design of a computer interface that allows use of the model as a management tool to improve the scheduling process. Specifically, an optimization model utilizing the network structure of the maximum flow model is implemented in the General Algebraic Mathematical System (GAMS), and a Microsoft VISUAL BASIC® computer program is used to create a Microsoft EXCEL®-based interface that is easily understood by the user.

I. INTRODUCTION

The Defense Fuel Supply Center (DFSC), headquartered in FT Belvoir, VA, is one of five inventory control points in the Defense Logistics Agency (DLA). As the petroleum materiel manager, DFSC is responsible for the acquisition, storage, and distribution of fuel to support the military services and over 4000 federal agencies. As a result, DFSC purchases more light petroleum products than any other single organization or company in the world. With a \$4.4 billion annual budget, DFSC procures, stores, and distributes over 148 million barrels of petroleum products annually. (DFSC, 1995)

The Bulk Inventory Distribution (BID) Branch at DFSC is the cognizant authority for managing bulk fuel inventories and distributing these fuels to meet worldwide military petroleum requirements. They manage 47 national stock numbers for petroleum, including products such as jet fuels, aviation gasoline, automotive gasoline, Navy propulsion fuels, lubricants and heating oils. For the U.S. military, three types of fuel account for approximately 98% of the total fuel supply including: JP-5, a kerosene-based jet fuel primarily used for U.S. Navy carrier based aircraft; JP-8, a kerosene-based jet fuel primarily used by the Air Force; and F-76, U.S. naval diesel fuel. See Figure 1.

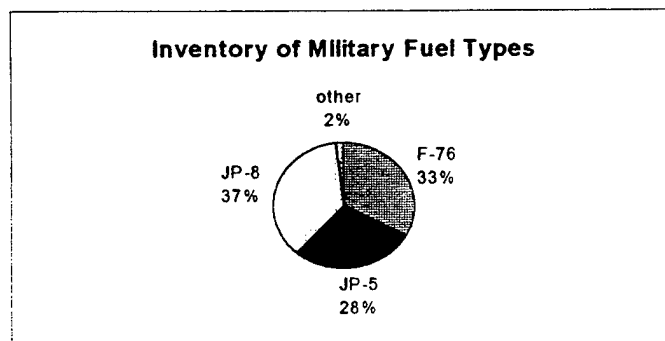

Figure 1. Military fuel types as a percentage of total volume (DFSC, 1995).

Military fuel transportation requirements are identified by demands which are initiated at storage facilities within four Defense Fuel Regions (DFRs) located around the globe. Defense Fuel Regions act as command and focal points for arranging and coordinating fuel delivery. These DFRs maintain a close working relationship with consumers, refineries, and various agencies to provide information and advice on transportation requirements, delivery patterns, and efficient, economical movement of fuel within their assigned geographical areas. Within each DFR, product requirements are identified and consolidated by a Joint Petroleum Officer (JPO) who works on the staff of the theater Commander in Chief (CINC). Through the JPO, each DFR submits a monthly fuel requisition to DFSC with demand projected for 120 days (current month plus three months). The DFR requests a product type, quantity, destination, delivery date, and mode of transportation.

DFSC delivers fuel products to the DFRs by truck, rail, pipeline, barge, and a fleet of bulk-cargo tankers which are controlled by Military Sealift Command (MSC). Of these delivery methods, movement by an MSC controlled tanker typically delivers less than 35% of the total volume of fuel (measured in barrels), yet is responsible for over 65% of the total transportation costs, requiring an annual budget of over \$240 million (Bochert, 1995). Figure 2 illustrates the relative costs of delivering fuel by each method of delivery.

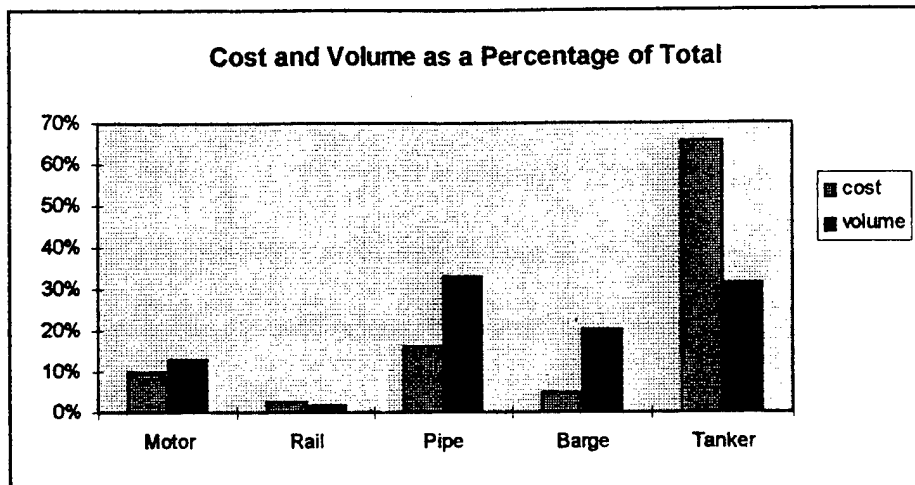

Figure 2. Relative costs of shipping fuel by each method of delivery.

If a tanker is required to make a delivery to a demand port, a scheduler at DFSC assigns it to load a specific quantity of a particular product from one of many source ports that are determined by the award of an annual contract. The important decisions required by the scheduler are to specify a feasible load port and time, and discharge port and time for each cargo such that the demand of the DFR is met and the tanker is utilized efficiently. Each tanker may be required to perform multiple lifts during the planning horizon, and the efficient sequencing of its cargo loads and discharges will enable a tanker to perform more lifts over time. These decisions are usually made for a planning horizon covering the current month plus three months, with revision of the schedule occurring during the planning horizon as contingencies arise or new requirements are identified.

The objective of this thesis is to aid scheduling planners in determining the most efficient cargo sequencing plan. This objective will be achieved through the development of a mathematical model to represent the cargo scheduling problem and the design of a computer interface that allows use of the model as a management tool to improve the

scheduling process. Specifically, an optimization model utilizing the network structure of the maximum flow model is solved and the Microsoft VISUAL BASIC® computer code is used to create a Microsoft EXCEL® interface.

The next chapter describes the current scheduling operations at DFSC. In it, we address the significant factors involved in the scheduling process, including the demand ports, source ports, and the tankers. Chapter III gives a detailed description of our mathematical model and includes a graphical description of the problem. Other works that have similarities to our model are discussed here, as well. Chapter IV discusses the implementation of our model, its results, and potential applications. A summary and conclusion is presented in Chapter V. Finally, the program code utilized to solve our problem and a user's guide are provided as appendices.

II. CURRENT OPERATIONS AT DFSC

The demand for movement of petroleum products arises at storage facilities in DFRs which submit their petroleum product requirements (product type, amount, and date required) to a Joint Petroleum Officer (JPO). The JPO consolidates requirements, determines priorities, and submits his needs to DFSC which translates the requirements into tanker cargoes and transmits them to the Tanker Division of the Military Sealift Command. The cargo information provided includes product type, amount, and load and unload locations and times. A typical cargo shipment consists of one or two types of fuel, a load port, and one or two delivery ports which are frequently close to each other.

The planning horizon for this problem is three months. Information on new cargoes is received monthly, so before reaching the end of the current three-month schedule, the current schedule is extended for another month on the basis of this new information. The schedule is also adjusted on a day to day basis due to changes in cargo requests and contingencies such as bad weather.

There are four DFRs that require fuel to be delivered by bulk-cargo tanker. The current method of scheduling tankers is done manually by three employees, each responsible for a DFR (one scheduler is responsible for two Defense Fuel Regions). They employ a poster-board that is drafted to represent a spreadsheet, a calculator, and corporate knowledge as their decision tools. Schedulers must consider, at a minimum, cargo type, cargo availability, cargo quantity, time constraints, load ports, discharge ports, load and discharge times, distance between ports, tanker capacity, tanker speed, tanker location, and tanker availability. Each schedule takes the scheduler approximately three to

five days to complete and requires close interaction with MSC. The workload does not permit manual generation and analysis of all potential schedules, thus the resulting schedule may not be efficient.

The major components of the cargo scheduling problem are the monthly demands submitted by the DFRs (or the slate), the source port contracts, and the MSC controlled tanker fleet. A description of each of these is provided below.

A. SLATE

Each DFR submits fuel requirements to DFSC on the tenth day of every month which projects fuel demands within that region for the current month plus three months. These requirements include a product type, quantity (in thousands of barrels, MBBLs), destination, delivery date, and mode of transportation (a tanker is defined as mode 1). The delivery date is defined as a period within a month with each month broken down into three periods of ten days (e.g., period 1 corresponds to days one through ten of the month, period 2 corresponds to days eleven through twenty, and period 3 corresponds to days twenty-one through thirty). Each month is assumed to have a total of thirty days. The delivery dates can be thought of as time-window constraints centered about the fifth, fifteenth, and twenty-fifth days of the month. An example of a possible slate is presented in Table 1. Note that the quantity demanded by a source port rarely exceeds 235 MBBLs, which is the maximum capacity of an MSC controlled tanker. Additionally, two types of fuel can be combined as one cargo, so long as their combined sum does not exceed the capacity of a tanker (i.e., September, Guam, JP-8 and F-76). This will be addressed further when we discuss the tanker fleet.

<i>Month</i>	<i>Product</i>	<i>Quantity</i>	<i>Destination</i>	<i>Delivery Period</i>	<i>Mode</i>
<i>JUL</i>	<i>F-76</i>	<i>235</i>	<i>PERL</i>	<i>2</i>	<i>1</i>
<i>AUG</i>	<i>JP-5</i>	<i>235</i>	<i>DGAR</i>	<i>3</i>	<i>1</i>
<i>SEP</i>	<i>JP-8</i>	<i>145</i>	<i>GUAM</i>	<i>1</i>	<i>1</i>
<i>SEP</i>	<i>F-76</i>	<i>90</i>	<i>GUAM</i>	<i>1</i>	<i>1</i>
<i>OCT</i>	<i>JP-8</i>	<i>235</i>	<i>CHIM</i>	<i>3</i>	<i>1</i>

Table 1. A typical set of fuel demands, or *slate*.

B. SOURCE CONTRACTS

The DFSC contracting base of suppliers ranges from small, local operations to some of the industry's leading manufacturers and covers the procurement of various bulk petroleum products for military requirements worldwide. The top ten contractors range from multi-national refining and distribution corporations, to small businesses, to foreign corporations. Although the entire contractor base comprises almost 1000 companies, these top ten are responsible for a significant portion of the 74% of the total fuel requirements which are awarded to bulk contracts. The most common products purchased are JP-5, JP-8, and F-76 (DFSC, 1995).

The worldwide source contract requirements are divided into four buying cycles:
Western Pacific--- Contracts are awarded each December for delivery January 1 through December 31.

U.S. East and Gulf Coasts--- These contracts are awarded each March for delivery April 1 through March 31.

Atlantic, European, and Mediterranean ---Awarded each June for delivery July 1 through June 30.

U.S. West Coast--- Contracts are awarded each September for delivery from October 1 through September 30.

Although specific details of the source contracts are not relevant, the contracts do provide two important inputs to the schedulers. First, the contracts provide an annual supply of fuel that can be lifted from a source port. This annual supply is prorated to determine a monthly supply capacity for each load source. Additionally, DFSC is contractually bound to load a minimum amount of the contracted quantity of fuel per year. If DFSC fails to lift the minimum quantity specified in the bulk contract, DFSC incurs a price penalty. Therefore, the schedulers track the amount of fuel lifted from individual contractors and seek to fulfill the minimum requirement by assigning load source ports accordingly.

Ultimately, the choice of a load port for a specific cargo is primarily determined by whether or not the source port has the required fuel type, the percentage of the annual contract that has been lifted from that port to date, and the total distance traveled if that port is used (i.e., the time required to ship the cargo if that source port is used).

C. CONTROLLED FLEET

The controlled fleet is comprised of bulk-cargo tankers (currently there are eight). Each of the ships in the controlled fleet has a known capacity, maximum speed, initial

location, and times at which the ship is available. The controlled fleet tankers have maximum capacities of approximately 235 MBBLS to 250 MBBLS. The tankers can partition different types of fuel to be delivered so long as the total amount of fuel in a cargo does not exceed the capacity of the tanker. Due to increased maintenance costs associated with operating at higher speeds, the controlled fleet is contractually obligated to operate at an average speed of 15 knots. The tankers are used on the basis of a long-term charter. They are maintained and operated by Military Sealift Command.

In addition to the MSC controlled fleet of tankers, short-term spot charters are hired by Military Sealift Command to satisfy demands that cannot be met by the tankers in the controlled fleet. If the number of tankers available for use is insufficient to meet the demand of the DFR, then a cargo is assigned to a short-term spot charter and is lifted for a fixed fee. Detailed information on spot charter vessels is neither known nor needed, since spot carriers undertake to lift individual cargoes on a contractual basis and schedule the ships required to do this.

III. CARGO SCHEDULING MODEL

Because of the wide range of configurations, achieving a general solution to the cargo scheduling problem is non-trivial. The traditional tanker routing problem has been treated in previous work for a restricted configuration of unit port discharges which does not determine loading and discharge dates (Dantzig and Fulkerson, 1954). Yet, partial, multi-port discharges are not uncommon occurrences within DFSC's Bulk Inventory Distribution Branch, and the assignment of load and delivery dates to cargoes is the crux of the scheduler's task. Our model addresses these aspects of the scheduling problem by embellishing the traditional model to capture the intricacies of a real world application at DFSC. The concept of delivery windows, which has seen limited attention in the published literature (perhaps due to the unique arrangement between DFSC and MSC), is addressed in our work. Also, we allow for the selection of an initial location and date of availability for each tanker which is yet another enhancement to the traditional transportation model. Finally, we solve this unique scheduling problem by creating a network of feasible sequences of consecutive shipments and transform this problem into the framework of the maximum flow problem. We approach the problem by using a solution procedure that utilizes the maximum flow model.

A. NETWORK STRUCTURE

We solve DFSC's tanker scheduling problem by constructing a network which contains a node c for each cargo and an arc from node c to node c' if it is possible to deliver cargo c' after completing cargo c ; that is, the start time of cargo c' is no earlier than the delivery time of cargo c plus the travel time from the destination of cargo c to the

origin of cargo c' . A directed path in this network corresponds to a feasible sequence of cargo pick-ups and deliveries. A simple network construction of the tanker scheduling problem is shown in Figure 3.

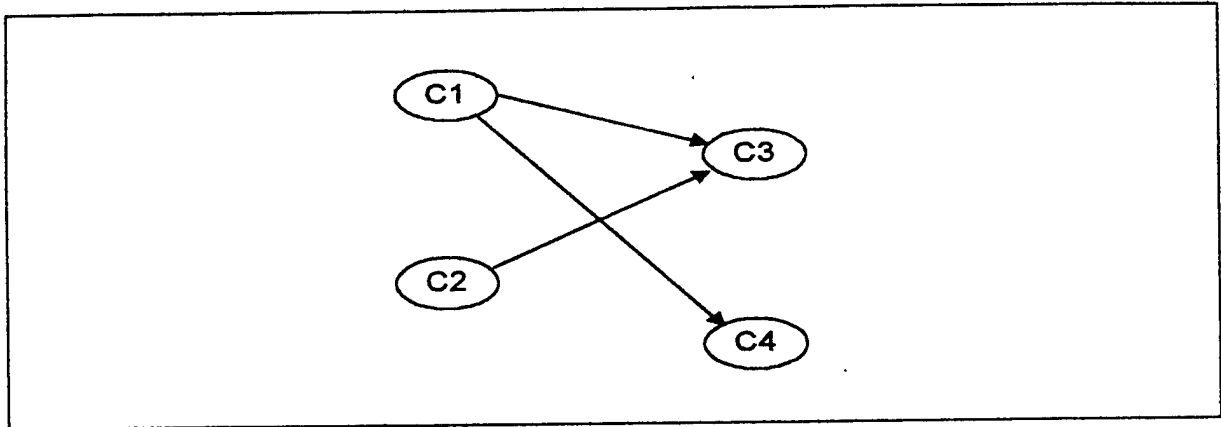

Figure 3. Network of feasible sequences of consecutive shipments.

We transform this scheduling problem to the framework of the maximum flow problem by splitting each node c into two nodes p,d and q,d' and add the arc $(p,d \rightarrow q,d')$. We set the lower bound on each arc $(p,d \rightarrow q,d')$ equal to one so that at least one unit of flow passes through this arc. We also add a source node s and connect it to the origin of each shipment, which represents putting a ship into service. Additionally, we add a sink node t and connect each destination node to it to represent taking a ship out of service. Each directed path $s \rightarrow t$ corresponds to a feasible schedule for a single ship. Finally, we set the capacity of each arc in the network to value one so that each cargo is delivered by only one tanker. As a result, a feasible flow value in this network decomposes into ship schedules and our problem is reduced to identifying a feasible flow of maximum value. A representation of the maximum flow model is depicted in Figure 4.

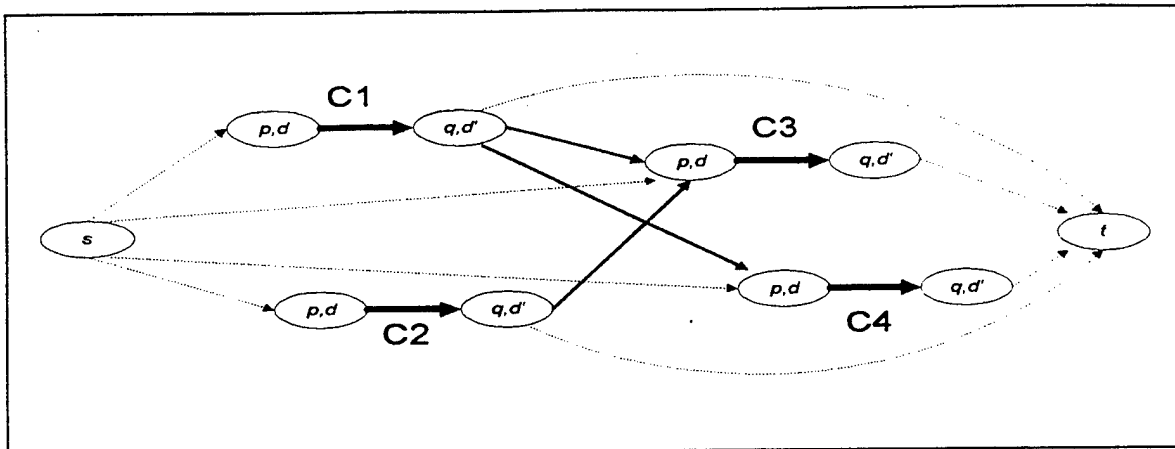

Figure 4. Network representation of the maximum flow model.

Finally, we embellish the framework of the maximum flow model to capture the intricacies of a real world application at DFSC. Each tanker is assigned as a separate source node that represents a port and day that the tanker becomes available for scheduling. For each tanker, therefore, an arc exists only for those cargoes that it can reach within the time constraint associated with the delivery of that cargo. Additionally, the required delivery date of a cargo allows for a ten day window in which the tanker can arrive and still be considered to arrive on time. This results in the creation of a large network with ten arcs to represent each cargo $[(p,d \rightarrow q,d'), (p,d+1 \rightarrow q,d'+1), (p,d+2 \rightarrow q,d'+2), \dots]$, where d is incremented for ten days and d' is equal to d plus the transit time from p to q . The sum of these ten arcs must be equal to one to ensure only one shipment is made for each cargo. For example, a simple three-day window can be represented as such: if cargo two can be delivered on day four, five, or six, then it can be represented by three different arcs: $(p,d4 \rightarrow q,d4$ plus the transit time from p to q), $(p,d5 \rightarrow q,d5$ plus the transit time from p to q), and $(p,d6 \rightarrow q,d6$ plus the transit time from p to q). Since

only one shipment is required, the three arcs sum to one. A complete representation of our network model with four cargoes is presented in Figure 5.

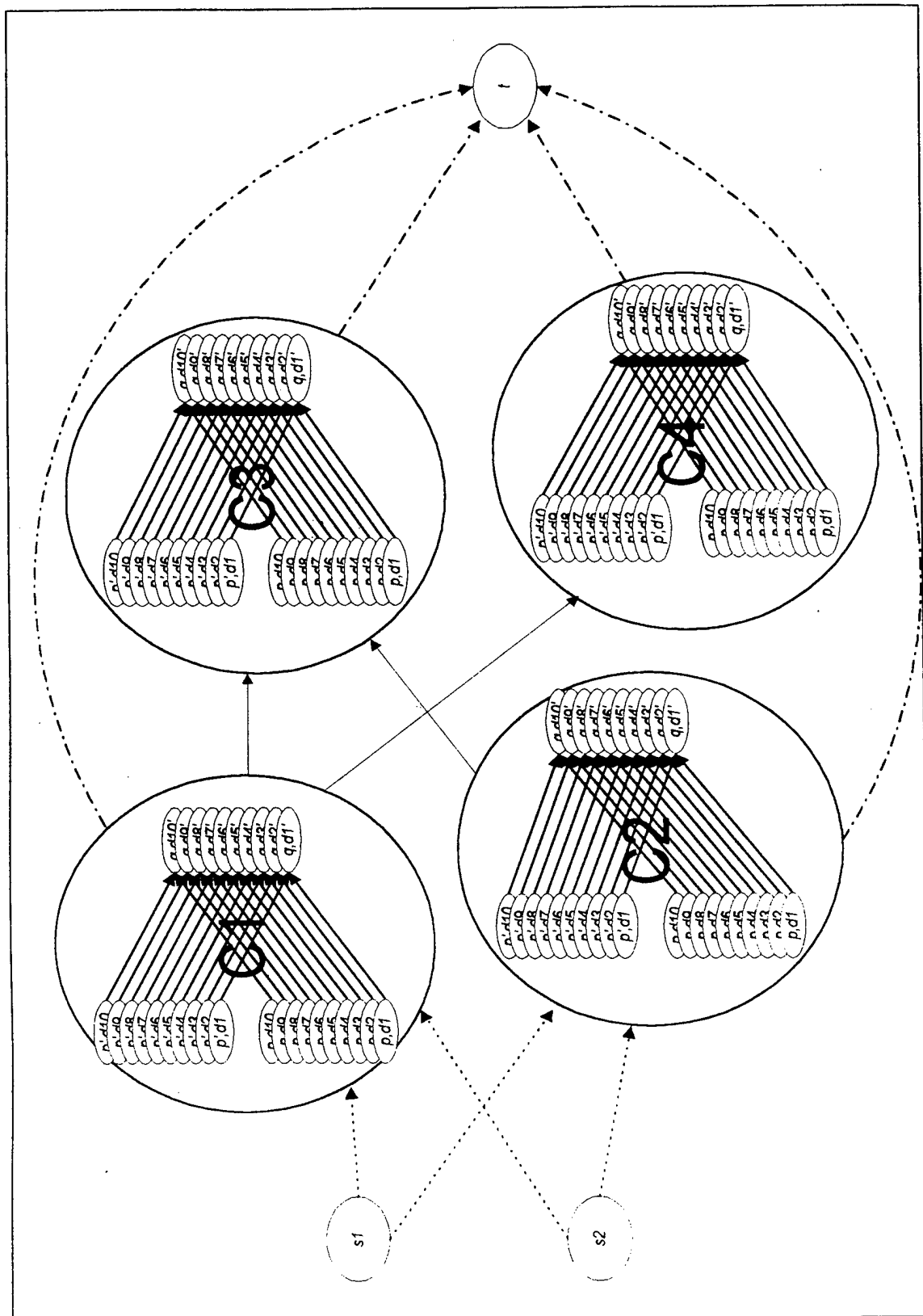

Figure 5. Representation of the scheduling model as a maximum flow problem.

B. MODEL ASSUMPTIONS

This model considers the optimal scheduling of cargo shipments with a known number of available tankers. Although DFSC does not manage the distribution of the bulk-cargo tankers that are in the controlled fleet, the schedulers at DFSC maintain a close working relationship with the operational planners at MSC and are aware of the number of tankers that will be operating in their region. Tanker routing is not specifically DFSC's concern, rather, the DFSC scheduler's task is to provide the most efficient load and discharge schedule possible; it is MSC's responsibility to route the individual tankers. By considering the known number of available tankers, however, our model will provide a solution to both the optimal scheduling and tanker routing schema.

Additionally, the tankers in the controlled fleet are considered to be homogeneous. All of the tankers in the bulk-cargo fleet have a maximum storage capacity of 235,000 barrels of fuel with the exception of one tanker which can carry 250,000 barrels. A cargo, therefore, is considered to be any combination of fuel that sums to less than 250,000 barrels. For instance, if a demand port requests 240,000 barrels of fuel on one delivery and a 235,000 tanker is assigned, then a cargo of 235,000 is delivered and the remaining 5,000 barrels is carried over to the next delivery. It is worth noting that in practice this rarely occurs. The JPOs within each DFR rarely, if ever, request more than 235,000 barrels for one cargo and make arrangements for additional cargoes if more fuel is required.

Occasionally, when two demand ports are closely located and their demand quantities are small, due to distance and quantity considerations, it is economically feasible

to schedule two separate ports for one unit cargo delivery. To model this occurrence of dual-port discharges, these ports are grouped into a cluster which can accept a shared unit cargo. We treat this cluster as a distinct discharge node within our network structure and include the days required to transit between them, as well as the time required to discharge fuel at the first discharge port, in calculating subsequent cargo deliveries.

To model tanker scheduling, the planning horizon is discretized into 120 days, which is considered to be four months (the current month plus three months) with thirty days per month. The fact that all months do not have exactly thirty days is insignificant because the utility of our model is based on maximizing the number of sequentially consecutive shipments over time rather than determining the exact dates of those shipments. The exact dates are an output of our result, however, and can be determined by simply corresponding the days in the 120 day planning horizon with the appropriate calendar days.

Finally, in order to formulate the tanker scheduling model as an integer program, it is necessary to round the transit time between ports into discretized integer days (all non-integers are rounded to the next highest integer day). The impact of this is negligible, however, due to the unexpected delays associated with entering and leaving port. Further, the purpose of this model is to determine the maximum sequence of consecutive shipments and it is less concerned with the actual time required for any one shipment. Additionally, by rounding up, any unscheduled delays for a shipment (i.e., delays entering/leaving port) may inadvertently be treated in the model.

C. MATHEMATICAL FORMULATION

Mathematically, the optimal tanker scheduling problem can be stated as follows:

Indices:

p, p'	load ports
q, q'	discharge ports
c, c'	cargo number, $c, c' = 1, \dots, C$
d, d'	day of arrival/departure of a tanker, $d, d' = 1, \dots, D$
m	month in planning horizon, $m = 1, \dots, M$
f	fuel type
s	source node representing tanker, $s = 1, \dots, S$
T	sink node representing end of planning horizon

Note that the values for M and S are predetermined by the scheduler. In practice, M usually represents a planning horizon of three or four months. The number of tankers available, S , is usually two or three.

Indexed Sets:

Δ_m $\{d: \text{set of days } d \text{ in month } m, \text{ i.e., } \Delta_m = \{d: 30(m-1) + 1 \leq d \leq 30m\}\}$

POE_c $\{(p, d): \text{set of load ports and departure dates for cargo } c\}$

POD_c $\{(q, d): \text{set of discharge ports and arrival dates for cargo } c\}$

Ω_s $\{(q, d): \text{port and day tanker } s \text{ becomes available}\}$

Data:

wf^d Weight assigned to prioritize early cargo deliveries

$sl_{f,q,d}$ Demand for fuel f by port q on day d

$pr_{p,f,m}$ Supply at port p of fuel f in month m

Binary Decision Variables:

$X_{(s,q,d),(c,p,d')}$ Indicates tanker s at port q on day d loads cargo c at port p on day d'

$Y_{(c,p,d),(c,q,d')}$ Indicates a tanker delivers cargo c from port p on day d to port q on day d'

$Z_{(c,q,d),(c',p,d')}$ Indicates a transit from port q on day d to load cargo c' at port p on day d'

$W_{(c,q,d),T}$ Indicates a tanker ends service after delivering cargo c at port q on day d

Formulation:

The Optimal Cargo Scheduling Problem

$$\text{Maximize: } \sum_c \sum_{(p,d) \in POE_c} \sum_{(q,d') \in POD_c} W_{(c,q,d),T} \cdot Y_{(c,p,d),(c,q,d')} \quad (1)$$

subject to:

$$\sum_c \sum_{d \in POE_c} \sum_{(q,d') \in \Delta_m} \sum_{(p,d'') \in POD_c} sl_{f,c} \cdot Y_{(c,p,d),(c,q,d')} \leq pr_{p,f,m} \quad \forall p,f,m \quad (2)$$

$$\sum_{(p,d) \in POE_c} \sum_{(q,d') \in POD_c} Y_{(c,p,d),(c,q,d')} \leq 1 \quad \forall c \quad (3)$$

$$\sum_c \sum_{(p,d') \in POE_c} X_{(s,q,d),(c,p,d')} = 1 \quad \forall s \quad (4)$$

$$\sum_s \sum_{(q,d) \in \Omega_s} \sum_c \sum_{(p,d') \in POE_c} X_{(s,q,d),(c,p,d')} = \sum_c \sum_{(q,d) \in POD_c} W_{(c,q,d),T} \quad (5)$$

$$\sum_s X_{(s,q,d),(c',p,d'')} + \sum_{c'' \neq c'} \sum_{(q',d') \in POE_{c'}} Z_{(c,q',d'),(c',p,d'')} = Y_{(c',p,d''),(c',q'',d''')} \quad \forall c', (p,d'') \in POE_{c'}, (q'',d''') \in POD_{c'} \quad (6)$$

$$\sum_{(p,d) \in POE_c} Y_{(c,p,d),(c,q,d')} = \sum_{c' \neq c} \sum_{(p,d'') \in POE_{c'}} Z_{(c,q,d'),(c',p,d'')} + W_{(c,q,d'),T} \quad \forall c, (q,d') \in POD_c \quad (7)$$

$$X_{(s,q,d),(c,p,d')} \in \{0,1\} \quad (8)$$

$$Y_{(c,p,d),(c,q,d')} \in \{0,1\} \quad (9)$$

$$Z_{(c,q,d),(c',p,d')} \in \{0,1\} \quad (10)$$

$$W_{(c,q,d),T} \in \{0,1\} \quad (11)$$

The objective function (1) maximizes the number of shipments made over time by each available tanker utilizing the earliest feasible dates for delivery. The first term, $w t^d$, is a weight assigned to ensure that the earliest possible delivery date is used. We allow the user to identify a value between 0 and 1 for $w t$, and we apply the value of day d in the planning horizon as the exponent. This ensures that a higher value is assigned to the earliest deliveries in the planning horizon which increases our objective function value. By weighting the delivery schedule to meet deliveries as early as possible, we reduce the number of idle days associated with a tanker. The second term, $Y_{(c,p,d),(c,q,d')}$, represents the actual delivery of a specific cargo c from a load port and day (p,d) to a discharge port and day (q,d') , where d' is equal to day d plus the transit time from port p to port q .

Constraint set (2) limits the amount of fuel to be loaded from each source port per month to the contractually-bound, prorated (we use one twelfth of the annual contract for each month) supply at that port. It states that $sl_{f,c}$, which is the demand of a fuel type f for a specific cargo c , must be less than the prorated supply provided at that load port in that month, $pr_{p,f,m}$. Constraint set (3) limits the number of deliveries of each cargo to at most one. Since each cargo has more than one $(p,d) \rightarrow (q,d')$ combination (one for every delivery day in the ten day window), their sum can be no greater than one. Constraint set (4) ensures that every tanker assigned to a schedule is utilized. Constraint set (5) ensures that all the tankers used finish service in the planning horizon and are sent to the sink node. Constraint sets (6) and (7) ensure the balance of flow into and out of load and discharge nodes, respectively. Constraint set (6) limits the availability of a tanker to deliver a cargo to the sum of only those entering service to deliver that cargo and those

completing delivery of a preceding cargo. Constraint set (7) provides for the tanker completing delivery of a cargo to either be assigned to deliver a later cargo or to go out of service at the sink node. Finally, constraint sets (8) through (11) force the variables X , Y , Z , and W to be binary. If one of these variables is equal to one, then that represents a tanker entering service, a cargo being delivered, a consecutive shipment is being made, or a tanker leaving service, respectively.

The computer source code of the mathematical formulation, which is used to solve a sample problem, is shown in Appendix A. A detailed sample problem, typical of those faced by DFSC, and its implementation on a microcomputer is discussed in the next chapter.

D. RELATED WORK

Ship-scheduling problems are among the earliest applications of mathematical programming beginning with the classic paper by Dantzig and Fulkerson (1954), and they have attracted much attention in the published literature. Dantzig and Fulkerson treated a ship scheduling problem in a military environment similar to the one presented here. Unlike our approach, which utilizes an enhancement of the maximum flow model, Dantzig and Fulkerson minimized the fleet size in the special case in which load and discharge dates are fixed.

A contemporary review of petroleum ship routing and scheduling models is provided by Ronen (1995). In his review, Ronen identifies a bulk-oil products dispatching system for the Tanker Division of the Military Sealift Command, which, similarly to the DFSC scheduling problem discussed here, addresses the tanker routing problem faced at

MSC (Fisher and Rosenwein, 1989). In the Fisher and Rosenwein system, a column generation technique using PASCAL computer code is utilized to identify all feasible schedules for each tanker. Then, a specified set of loads is dispatched using a set packing model which considers each feasible schedule for each vessel. Fisher and Rosenwein then solve the set-partitioning problem directly with a dual algorithm. The model developed by Fisher and Rosenwein solved problems with up to a thousand columns, but the system has not been used due to changes in personnel (Ronen, 1995).

Similarly, in a non-military environment, Bausch, Brown and Ronen utilize a column-generation method to develop a product dispatching system for a given set of loads, which uses an elastic set partitioning model, where all feasible schedules of the vessels are considered. Bausch, Brown and Ronen solved problems with thousands of binary variables and dozens of cargoes, and that system is being used operationally (Bausch, Brown, and Ronen, 1991).

In addition to the original works developed during the 1950s, and the more current models which make use of computer programming to generate columns for candidate schedules, linear programming coupled with heuristic rounding procedures has been applied to more general versions of the ship-scheduling problem (McKay and Hartley, 1974 and Laderman et al., 1966). McKay and Hartley tried to minimize fleet operating cost and the cost of buying oil products at the loading ports. Similar to the approach used here, McKay and Hartley used binary route selection variables, but they employed continuous solutions and an approximate heuristic. Laderman, Gleiberman and Egan tried to minimize the number of ships used. Many nonmilitary ship scheduling problems have

also been dealt with which tried to minimize operating and chartering costs, and the profit contribution of optional cargoes (Brown, Graves, and Ronen, 1987).

Finally, there are two other works that present solutions that are relevant to our approach (Briskin, 1966 and Ahuja, et al., 1993). Briskin (1966) describes a clustering procedure to determine delivery dates which is similar to the technique used here. Finally, in a simplified example, Ahuja, et al. (1993) transform a tanker problem into the framework of the maximum flow problem which is similar to our approach.

IV. IMPLEMENTATION AND APPLICATIONS

The cargo scheduling model is implemented on a 486/33 MHZ personal computer using the Generic Algebraic Modeling System (GAMS) (Brooke et al., 1992). It consists of an input file, the GAMS source code, and an output file which reports the results of the model. The interface is developed through VISUAL BASIC computer code which allows a MICROSOFT EXCEL spreadsheet to communicate with the GAMS formulation model. The schedulers at DFSC are accustomed to operating with an EXCEL spreadsheet and, through the VISUAL BASIC program, the GAMS formulation remains virtually invisible to the user. This chapter discusses the program interface, presents a sample problem faced at DFSC, and finally, discusses potential applications of this model as a decision aid to scheduling planners.

A. PROGRAM INTERFACE

The transfer of input data from EXCEL to the GAMS formulation and then outputting the model's results, although simplified by GAMS, is not a seamless process. The unintelligent user would find the model useless without a smooth interface that, in effect, hides the GAMS model beneath a familiar EXCEL spreadsheet. In order to do this, we have developed a computer program that provides a menu-driven, EXCEL-based interface that is easily understood and utilized by anyone knowledgeable of scheduling operations at DFSC. Specifically, the user will be prompted to input the data into a spreadsheet that is identical to the format that it is currently being used to report data. Additionally, the user will provide answers to a few simple questions concerning the number of tankers to use, their starting locations and dates, the length of the planning

horizon, etc. The scheduler can choose to utilize the GAMS model from a menu of options. The menu of options allows the user to i) update the problem by entering data, ii) run the model, and iii) output the results. Sensitivity analysis can be performed by varying the input parameters and observing the results of the model. Additionally, if one wishes to make changes to the structure of the input data, that option is available to the knowledgeable user.

GAMS specifies our mathematical formulation in a declarative algebraic language and automatically generates a machine readable constraint matrix to solve this large-scale problem quickly and efficiently (Mitra et al., 1994). The flexibility of GAMS enables us to define the problem concisely and allows for the creation of a user-friendly "front-end" and "back-end" which is used to input data and interpret the results of the model through a spreadsheet. The problem is concisely defined in GAMS by the "dollar operator" which restricts the indices of expressions so that only a desired subset of variables and constraints is generated. The ability of GAMS to read input data and create output files in a spreadsheet is accomplished through use of the "include" and "put" commands respectively.

In order to make the model useful, the schedulers must be able to interpret its results. Similar to the "front-end" development, the "back-end," or output, of the model is accomplished through VISUAL BASIC computer code that allows the GAMS model results to be output into a format that is easily interpreted by the scheduling planners at DFSC.

When utilizing the cargo scheduling model, the user may choose to update the slate, edit the source contracts, or define the number, locations, and start dates of the tankers. Additionally, the user may specify the number of days used to determine load and discharge times, and assigns a weight to the delivery days. Then the user is prompted to "prep" the model which is the action that converts the data into a text file that can be read into GAMS. Then, by choosing to run the model, the formulation will begin to solve the problem. When an optimal solution is reached, the user will be prompted to print an output report. A detailed description of the computer interface, including illustrations, is presented as a User's Guide in Appendix B. The VISUAL BASIC computer code used to implement the model is attached as Appendix C.

B. SAMPLE PROBLEM

In Chapter III, the optimal cargo scheduling model is formulated as an integer program which maximizes the flow (or number of shipments) through a network of fuel supply and demand ports with delivery time-window constraints. To illustrate the usefulness of this formulation in solving the scheduling problem, this section presents a sample problem faced by DFSC. Next, we illustrate the results of the optimal solution obtained by utilizing our GAMS formulation model and we discuss the effectiveness of our model.

As an illustration, a sample DFSC scheduling problem was constructed using actual data from a historical operation. The data includes the slate of fuel demands by product type, quantity, location, and date for one of the four Defense Fuel Regions. The total fuel requirements of this sample slate amount to twenty-eight separate fuel types,

discharge ports, and delivery date combinations which are spaced over a planning horizon of four months. Also included is the source contract data and the associated load ports and monthly supply constraints for that region. Additionally, the number of tankers and their starting locations and dates are provided.

Using our cargo scheduling model, an optimal solution to the DFSC scheduling problem was obtained in less than thirty minutes. Our model considered the efficient scheduling of fifteen tanker cargoes of various fuel types, quantities, locations, and times. It assigned a load port, load date, discharge port, and discharge date for each cargo. It also identified one cargo as a candidate for spot charter. Additionally, in this example, our model considered dual discharge ports, e.g., when a tanker cargo is shared between two discharge ports is assigned several cargoes to be delivered accordingly.

Our model used two tankers to complete the scheduling plan and required one spot charter. In addition to providing the best load port, load date, discharge port, and discharge date combinations, the solution provided an optimal routing scheme for the tankers as follows: tanker 1 enters service at Roosevelt Roads, Puerto Rico on day three of the scheduling horizon. It arrives at Houston on day 15 to load cargo 1 and delivers it to Beaufort, NC on day 21. It continues service, delivering a total of 8 tanker cargoes, before leaving service on day 120. Likewise, the second tanker begins service on day 7 and transits to Houston where it will arrive on day 16 and load cargo 2. It will then transit to Key West, FL and Jacksonville, FL where it will complete a dual-port discharge delivery of cargo 2 on day 21. Tanker 2 continues service, delivering a total of 6 tanker cargoes, before leaving service on day 111. Cargo 9 is not delivered by the tankers due to

a violation of the supply prorata constraint. Delivery of cargo 9, with only two tankers available, would require i) rescheduling the cargo into another month that would not violate the prorata constraint, ii) hiring a spot charter to perform the delivery, or iii) a violation of the prorata constraint that would impact future fuel supply at that port. The graphical results of the solution to the sample problem are presented in Figure 5.

The utility of our model is most apparent when one considers the relative speed in which it solves the DFSC scheduling problem. Under normal circumstances, using the same slate and source port data, a manual schedule could be generated using a calculator, poster-board, and professional knowledge, in approximately three to five days. This manually generated schedule would be completed through deliberate discussions between DFSC and MSC personnel until an agreement on a feasible schedule was reached. However, the resulting schedule, while feasible, may not be efficient. Our cargo scheduling model achieves a significant improvement in the time required to complete a schedule. Additionally, our model is mathematically sound, ensuring that the proposed schedule is optimally efficient.

Our example considers the scheduling of cargoes in one of four DFRs. The scheduler for each DFR is faced with approximately the same level of demands in a scheduling period and therefore each region requires approximately three to five days to complete a schedule. If one considers the potential time saved by implementing a model similar to the cargo scheduling model developed here, the potential savings are not insignificant. Specifically, with four regions requiring three to five days of effort, the time required to complete the entire schedule for all of the DFRs is approximately twelve to

twenty total workdays and can involve numerous personnel. Our model can solve the scheduling problem for all four regions in roughly less than two hours. Additionally, there exists the possibility that a manually generated schedule may not be the most efficient, resulting in unnecessary days of tanker usage. At an estimated cost of \$20,000 dollars per tanker-day of operation, significant savings could be realized by implementing a cargo scheduling model to aid in the scheduling process (Bochert, 1995).

Our cargo scheduling model produced an optimal solution to the cargo scheduling problem that resulted in 221 tanker-days of operation in which 14 cargoes were lifted over a 120 day planning period. The problem required approximately 5 minutes to input the data, and GAMS took approximately 25 minutes to generate 21,828 binary variables and 45,597 constraints and optimally solve the problem on a 486/33MHZ microprocessor-equipped machine. To increase the usefulness of our model, we felt that it was important for the model to be run on a microcomputer, and we sought to keep the total solution time to less than 30 minutes. This allows for the model to be used more frequently and is sufficient to run several scenarios for a single DFR's schedule. In order to achieve this, the model is best suited to solve problems within one Defense Fuel Region at a time with approximately 20 cargoes or less. Problems of greater scope than one DFR's demand slate would quickly result in a very large network that would require significantly more computer time to solve.

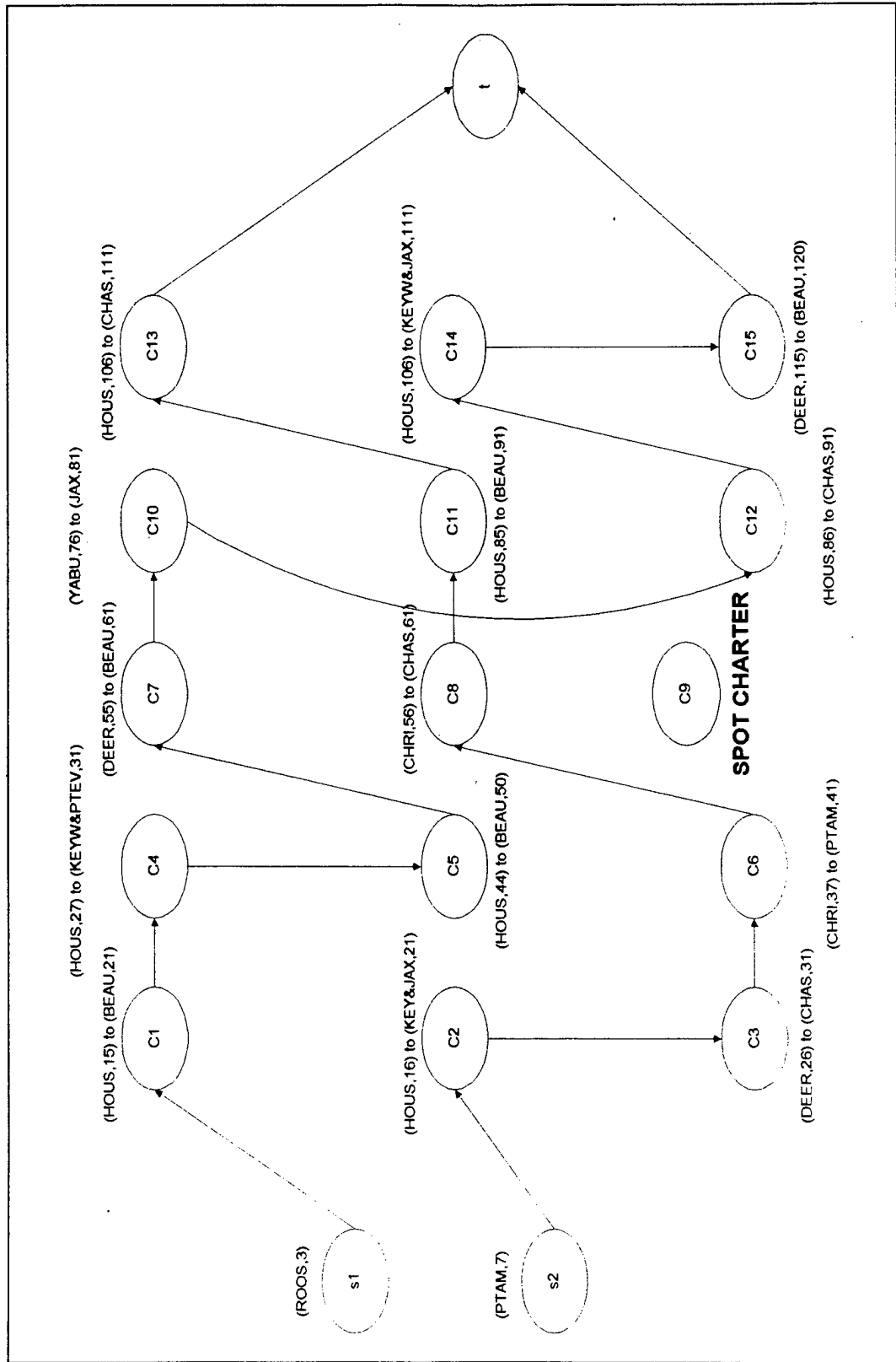

Figure 6. Optimal solution to the sample problem using the cargo scheduling model.

C. APPLICATIONS

There are many aspects of scheduling problems that can be solved through the use of linear programming. For instance, one might want to determine the best way to schedule a set of required cargo shipments, the shortest route for a tanker to take to meet its demand, or the number of tankers required for a set of delivery constraints. This thesis provides a model that can be manipulated to provide answers to these basic questions and can give valuable insight to policy planning and analysis of scheduling operations.

The optimal scheduling problem modeled in this thesis seeks to maximize the number of consecutive cargo shipments made by a bulk-cargo tanker. The solution to this problem provides, as a bi-product, an optimal routing sequence for each tanker. Although this tanker routing information is not necessary for DFSC, it can be utilized in cooperative scheduling with MSC and could even be used by the MSC tanker scheduling planners.

Another important application of this model involves sensitivity analysis to determine tanker shortfalls or spot-charter requirements. If there exists any "slackness" in the variables, then the number of tankers available for use might be altered to determine if the tanker could be used elsewhere. Additionally, if all of the shipments cannot be made by the given number of tankers, the model identifies this unmet cargo demand as a candidate for spot-chartering. The use of spot-charters is an expensive alternative for scheduling operations and this modeling tool can provide a quick and accurate analysis of the benefit of this alternative.

Another potential application of this model is to answer urgent, unplanned scheduling problems of any scale. This type of problem can range from a one-time

demand that emerges within a DFR with little notice, to planning the fuel mobility requirements for a surge or sustainment military operation. The model is not limited to the traditional peacetime application currently in use at DFSC. As such, it may prove to be an invaluable tool in planning for fuel mobility during crisis actions.

Finally, the model is not limited to the tanker operations at DFSC. Within many of the DFRs, multiple barges are used to transport fuel from port to port. This can be very expensive and time consuming without efficient scheduling and planning. This model could be tailored to solve barge scheduling problems that arise within the DFRs.

V. CONCLUSION

A. SUMMARY

This thesis develops a tanker scheduling optimization model to aid in the efficient delivery of bulk-cargo fuels within the Department of Defense (DOD). Specifically, an integer-based mathematical program is used to determine the maximum flow of specific fuel types and quantities through a network of load ports and delivery ports with delivery time-window constraints. The objective is to maximize the number of consecutive shipments performed by a tanker subject to time and capacity constraints. The result of our model provides an optimal schedule of sequential cargo deliveries to be planned by DFSC. As a bi-product of the output of our model, one can determine an optimal routing sequence for each tanker. Additionally, any demand ports that may be candidates for spot chartering can be identified.

The optimal tanker scheduling model is implemented in GAMS and is used to consider issues important to scheduling and planning of bulk fuel deliveries. The model is accessed through a spreadsheet-based interface which provides an output file that is easily understood by the scheduling planners. It is a menu-driven program that will optimize the delivery of bulk fuels to Defense Fuel Regions which submit their product requests to the Defense Fuel Supply Center. The implementation of a user-friendly interface allows scheduling managers to quickly analyze the effects of alternate scheduling proposals. Additionally, the model has many applications that can be exploited to improve the efficiency of bulk cargo deliveries within other agencies of DOD, including barge deliveries within a DFR and tanker routing for MSC.

Although a side-by-side comparison of our model's results with a manually generated schedule was not conducted due to a lack of data, the benefits of our model are evident. Significant savings could be immediately realized in DFSC scheduling operations by utilizing a mathematical programming model like the one developed by this thesis. Specifically, our model provides the optimal sequence of cargo shipments which, when compared to historical plans implemented by DFSC, shows considerable improvement in the efficiency of tanker utilization. By reducing the number of tanker-days required to complete a particular set of demands, a scheduling planner at DFSC is allowed an opportunity to schedule more shipments over time or to use fewer tankers to complete those shipments. At an estimated cost of \$20,000 per tanker-day of operation, the savings potential is quite apparent (Bochert, 1995).

B. AREAS FOR FURTHER RESEARCH

As a result of this thesis experience, the following topics are suggested for future research efforts:

1. Formulation of a minimum cost objective subject to a minimum amount of flow to provide an explicit analysis of the most cost effective method of delivering fuel. The possibility of using stochastic programming in the modeling of transportation costs should be explored.
2. The model could be reformulated to determine the minimum number of tankers required for a set of deliveries within a DFR. This would provide better guidance as to how MSC should allocate the bulk-cargo tanker fleet and answer questions about potential spot-charter candidates.

3. The model could be expanded to solve the global flow of fuel by the entire bulk tanker fleet at once. This would simply require the time-consuming task of determining the distance matrix between all ports of interest throughout the world, rather than solving four DFR subproblems.

APPENDIX A. GAMS SOURCE CODE

The following text is a copy of the GAMS source code for solving the optimal cargo scheduling problem for one of the four DFRs.

```
$TITLE LT Jorge Quiroga, LT Jason Strength
$$TITLE Tanker Scheduling Model
*-----GAMS AND DOLLAR CONTROL OPTIONS-----
$OFFUPPER OFFSYMLIST OFFSYMREF
OPTIONS
* output control
  LIMCOL = 0 , LIMROW = 0 , SOLPRINT = OFF , DECIMALS = 2
* cpu and iteration limits for the solver
  RESLIM = 9000, ITERLIM =900000
* optimality criterion for integer programs
  OPTCR = 0.1,
* random number generator seed
  SEED = 3141;
*-----INDICES-----

SETS S Ships/S1,S2/
  T Out of Service sink node /T0/
  P Load Ports /DEER, HESS, CHRI, ARUB, YABU/
  Q Discharge Ports/ CHAS, BEAU, KWES, KWPE, JAX, KJAX,
    PTAM, PTEV, ROOS,GTMO/
  C Cargoes /C1*C5/
  D Days in planning Horizon/D1*D130/
  M /M0*M4/
  F Fuel Type /JP5, JP8, F76/;
ALIAS (S,SP), (P,PP), (Q,QP,QOA), (C,CP, CPP), (D,DP,DPP,DOA);

SET DELTA (M,D) /M0.D1*D10, M1.D11*D40, M2.D41*D70,
  M3.D71*D100, M4.D101*D130/;

SET OMEGA(S,QOA,DOA) Ship S become available at port Q on day DOA
/S1.ROOS.D3, S2.KWES.D4/;

* This set will be in separate file
SET POE (C,P,D)
/C1.DEER.D6*D15, C1.HESS.D6*D15,
C2.DEER.D6*D15, C2.HESS.D6*D15,
C3.DEER.D17*D26, C3.HESS.D17*D26,
C4.DEER.D17*D26, C4.HESS.D17*D26,
```

C5.CHRI.D15*D24, C5.ARUB.D19*D28/;
 * This set will be in separate file
 SET POD(C,Q,D)
 /C1.BEAU.D11*D20, C2.KJAX.D11*D20,
 C3.CHAS.D21*D30, C4.KWPE.D21*D30, C5.ROOS.D21*D30 /;

SCALAR WEIGHT/0.95/;
 SCALAR TK Number of Tankers Available /2/;

*-----DATA-----

PARAMETER SL(F,C) Slate for fuel F at port Q on Day D
 /JP5.C1 200, F76.C1 100,
 JP5.C2 150, JP8.C2 150,
 JP5.C3 300, F76.C3 150,
 JP8.C4 140, F76.C4 140,
 F76.C5 200/;

PARAMETER PR(F,P,M) Prorata for fuel F at port P on Month M
 /JP5.HESS.M0 400, JP8.HESS.M0 350, F76.HESS.M0 500,
 JP5.DEER.M0 250, F76.DEER.M0 350, F76.CHRI.M0 250,
 JP5.HESS.M1 400, JP8.HESS.M1 350, F76.HESS.M1 500,
 JP5.DEER.M1 250, F76.DEER.M1 350, F76.CHRI.M1 250,
 F76.ARUB.M1 150 /;

TABLE

TRQP(Q,P) transit time from source port P to delivery port Q (in days)

	ARUB	CHRI	HESS	YABU	DEER
BEAU	4.2	4.4	4.3	3.6	4.3
CHAS	3.9	4.0	3.8	3.2	3.8
GTMO	1.5	3.8	3.7	1.7	3.7
JAX	.7	3.7	3.5	3.3	3.5
KWES	3.0	2.4	2.3	3.0	2.3
PTAM	3.7	2.3	2.0	3.6	2.0
PTEV	3.0	2.9	2.7	2.7	2.7
ROOS	1.2	5.2	5.0	0.1	5.0
KJAX	3.7	3.7	3.5	3.3	3.5
KWPE	.0	2.9	2.7	2.7	2.7;

TABLE

TRPQ(P,Q) transit time from delivery port Q to source port P (in days)

	BEAU	CHAS	GTMO	JAX	KWES	PTAM	PTEV	ROOS	KJAX	KWPE
ARUB	4.2	3.9	1.5	3.7	3.0	3.7	3.0	1.2	5.3	4.6
CHRI	4.4	4.0	3.8	3.7	2.4	2.3	2.9	5.2	4.7	4.0
HESS	4.3	3.8	3.7	3.5	2.3	2.0	2.7	5.0	4.6	3.9
YABU	3.6	3.2	1.7	3.3	3.0	3.6	2.7	0.1	5.1	4.4
DEER	4.3	3.8	1.7	3.5	2.3	2.0	2.7	5.0	4.6	3.9;

*-----VARIABLES-----

Binary Variables

X(S,Q,DOA,C,P,DP) In Service Arcs members of Inserv

Y(C,P,D,C,Q,DP) Delivery arcs members of Delta

Z(C,Q,D,CP,P,DP) Return arcs members of Romeo

W(C,Q,D,T) Out of Service arcs member of outserv ;

VARIABLES

DELIVERY 'Objective function value';

*-----FORMULATION-----

EQUATIONS

OBJ Objective is to maximize shipments

SUPPLY(F,P,M) Supply per fuel type at port of origin on month M

ONEPER(C) One Delivery per Cargo window

USEEACH(S) Every ship available must go into service

ALLOUT(T) All Ships must go out of service

FLOWBALP(C,P,D,CP,Q,D) Flow balance equation on P Nodes

FLOWBALQ(C,Q,D) Flow balance equation on Q Nodes;

*-----MAXIMIZE-----

OBJ.. DELIVERY =E=

SUM((C,P,D)\$ POE(C,P,D),

SUM((Q,DP) \$ ((POD(C,Q,DP)) AND

((ORD(D)) EQ (ORD(DP) - CEIL(TRPQ(P,Q))))),

(WEIGHT**((ORD(DP)-10))*Y(C,P,D,C,Q,DP)));

*-----SUBJECT TO-----

ONEPER(C)..

SUM ((P,D) \$ POE(C,P,D),SUM((Q,DP) \$ ((POD(C,Q,DP)) AND

((ORD(D) + CEIL(TRPQ(P,Q))) EQ ORD(DP))), Y(C,P,D,C,Q,DP))) =L= 1;

SUPPLY (F,P,M) ..

SUM ((C,D) \$ (POE(C,P,D) AND DELTA(M,D)),
SUM ((Q,DP) \$ ((POD(C,Q,DP)) AND ((ORD(D) + CEIL(TRPQ(P,Q))) EQ
ORD(DP))), SL(F,C) * Y(C,P,D,C,Q,DP)) =L= PR(F,P,M);

USEEACH(S)..

SUM ((QOA,DOA) \$ OMEGA(S,QOA,DOA),
SUM ((C,P,D) \$ ((POE(C,P,D)) AND
(ORD(DOA) LE (ORD(D) - CEIL(TRQP(QOA,P))))),
X(S,QOA,DOA,C,P,D)) =E= 1;

ALLOUT(T)..

SUM ((C,Q,D) \$ POD (C,Q,D), W(C,Q,D,T)) =E= TK;

FLOWBALP(C,P,D,C,Q,DP) \$ ((POE(C,P,D) AND POD(C,Q,DP)) AND
((ORD(D) + CEIL(TRPQ(P,Q))) EQ ORD(DP))) ..

SUM((S,QOA,DOA) \$ (OMEGA(S,QOA,DOA) AND
(ORD(DP) GE (ORD(DOA) + CEIL(TRQP(QOA,P))))), X(S,QOA,DOA,C,P,D)) +
SUM((CPP,QP,DPP) \$ ((ORD(CPP) NE ORD (C)) AND
((POD(CPP,QP,DPP)) AND (ORD(D) GE (ORD(DPP)+CEIL(TRQP(QP,P)))))),
Z(CPP,QP,DPP,C,P,D)) =E= Y(C,P,D,C,Q,DP);

FLOWBALQ(C,Q,DP) \$ POD(C,Q,DP)..

SUM((P,D) \$ ((POE(C,P,D)) AND ((ORD(D) + CEIL(TRPQ(P,Q))) EQ ORD(DP))),
Y(C,P,D,C,Q,DP)) =E=

SUM((CP,PP,DPP) \$ ((ORD(C) NE ORD (CP)) AND ((POE (CP,PP,DPP)) AND
(ORD(DPP) GE (ORD(DP)+ CEIL(TRQP(Q,PP))))), Z(C,Q,DP,CP,PP,DPP)) +
W (C,Q,DP,'T0');

*-----RESULTS-----

MODEL SHIPTRANS /ALL/;
SOLVE SHIPTRANS USING MIP MAXIMIZING DELIVERY;

DISPLAY DELIVERY L,X,L,Y,L,Z,L,W,L;

APPENDIX B. USER'S GUIDE

The following user's guide is a step-by-step set of instructions on the use of the cargo scheduling model interface.

A. BEFORE GETTING STARTED

The cargo scheduling model requires Microsoft EXCEL version 5.0 or higher and the Generalized Algebraic Modeling System (GAMS) optimization solver in order to be implemented onto a microcomputer. For proper operation, the file "csm.xls" should be installed in its own directory, and in the same drive as the GAMS solver.

Additionally, the user is cautioned that this computer program has not been exercised for all cases of interest. While every effort has been made, within the time available, to ensure that this program is free of computational and logical errors, it cannot be considered validated. Any application of this program without additional verification is at the risk of the user.

B. FRONT PAGE MENU

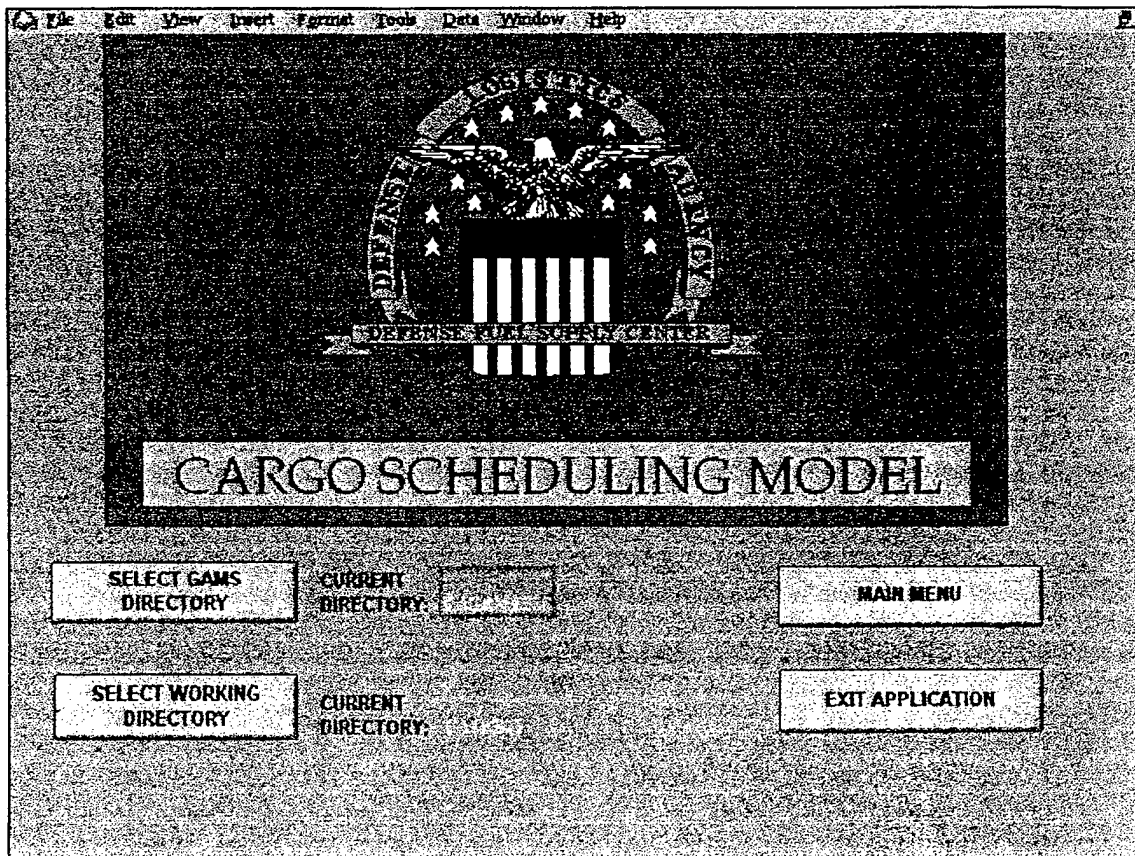

Figure 1. Front Page to the Cargo Scheduling Model.

1. **Select Gams Directory** - Press to select the "gams.bat" file and the directory where it resides, if the current directory is not the correct directory.
2. **Select Working Directory** - Press to select the "csm.xls" (EXCEL Interface) file and the directory where it resides, if the current directory is not the correct directory.
3. **Main Menu** - Press to access the MAIN MENU. A dialog box requesting selection of a DFR region will appear (see Figure 2). Select the appropriate region and then press "OK."

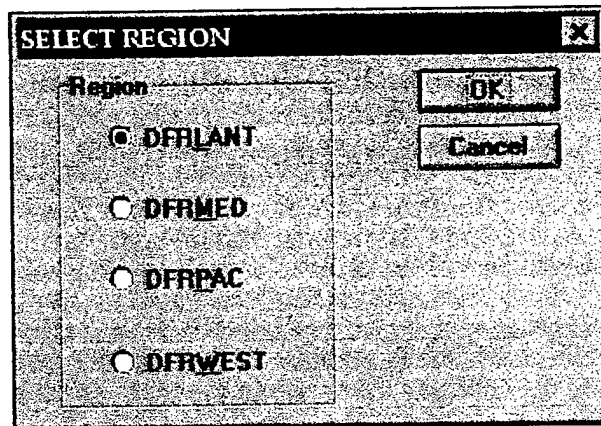

Figure 2. Select Region Dialog Box

4. **Exit Application** - Press to exit Microsoft EXCEL and save all the data.

C. MAIN MENU

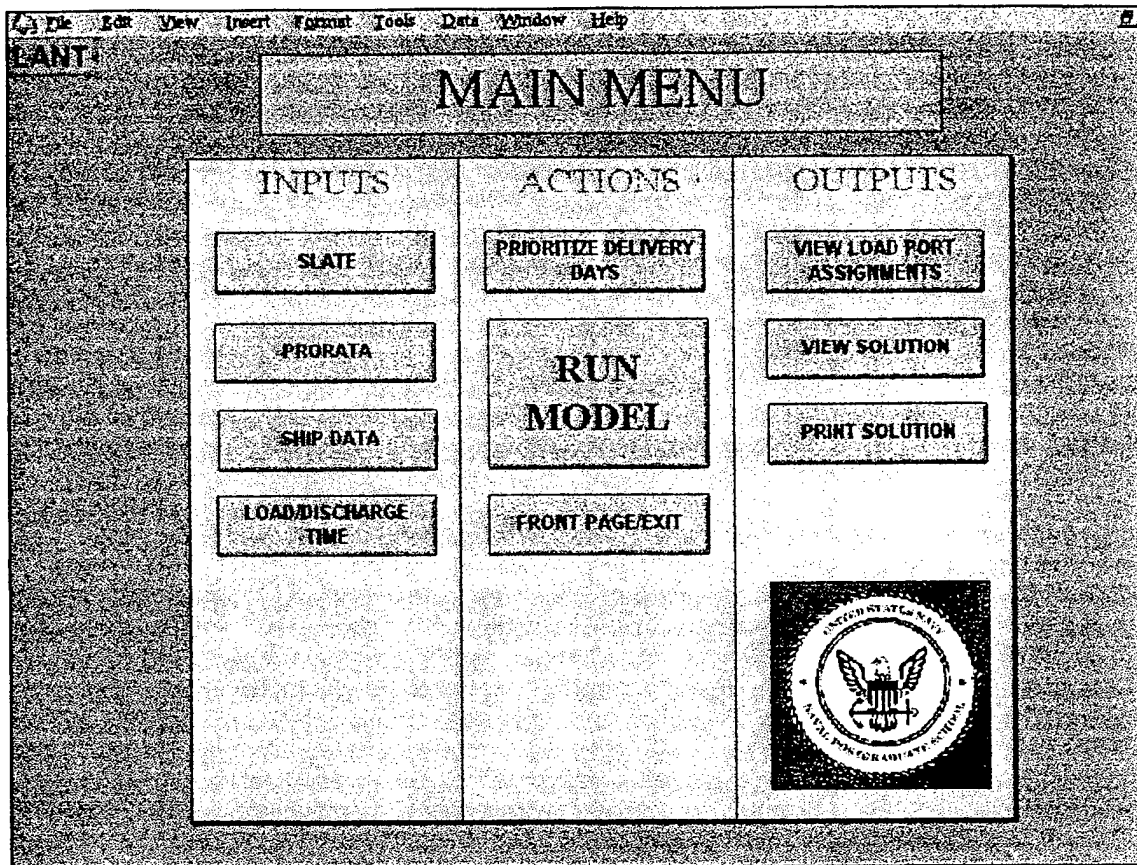

Figure 3. Cargo Scheduling Model Main Menu

1. INPUTS (Refer to Figure 3)

a. **Slate** - Press to access the Slate Input Sheet for data entry/review. A description of the Slate Input Sheet is included on page 45.

b. **Prorata** - Press to access the source contract list and Prorata Input Sheet for data entry/review. Refer to page 47 for further information.

c. **Tanker Data** - Press to change the number of ships available in the region of interest. Number selected should not include spot-chartered ships unless they will be used for the entire planning horizon.

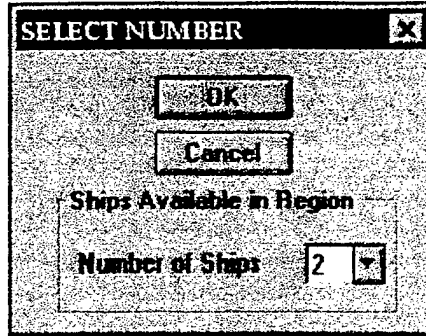

Figure 4. Number of Ships Available Dialog Box

After pressing “OK” (as shown in Figure 3), the following dialog box appears:

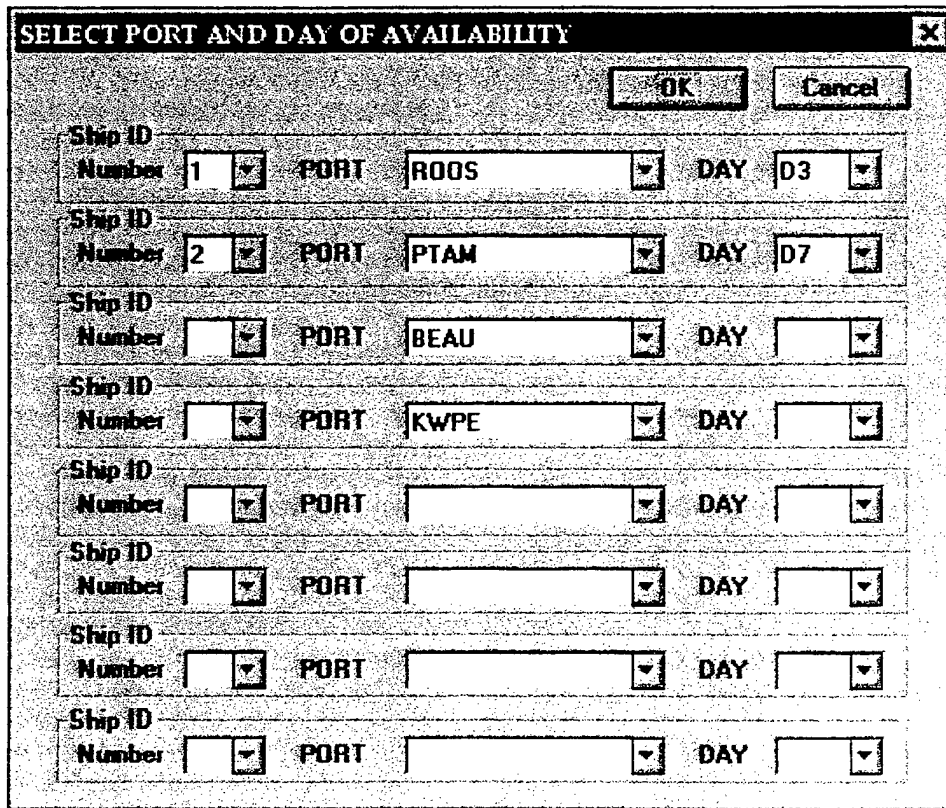

Figure 5. Ship Availability Information Dialog Box

For each non-empty Ship ID Number, select the port where each ship becomes available and the day it becomes available. D1 to D10 correspond to the ten days prior to the beginning of the planning horizon. D11-D130 is the range of the planning horizon, where D11 is the first day that a delivery could be made. Selecting port and day in a row where no Ship ID Number is shown will not affect the data.

Note: The codified day term can be interpreted in the following manner. D113 represents the third day in period eleven. The last digit stands for one day in a ten day period; the preceding two digits (one digit in the case of numbers below 10) stand for the period. For example, D120 is the tenth day in period 11. This convention is also used in the interpretation of the solution.

d. **Load/Unload Time** - Press to change the number of days a tanker requires to load/discharge its cargo. The number selected will be the same for all cargoes at all ports in the current planning horizon. The following dialog box will appear (see Figure 6). Use the spinner control to change the number of load/unload days required.

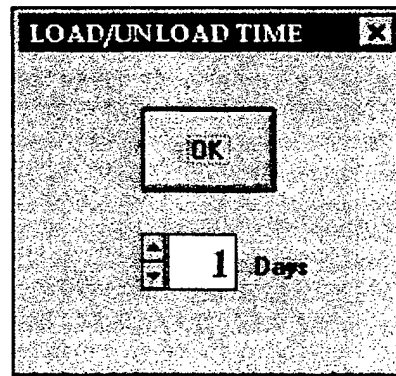

Figure 6. Load/Unload Time Dialog Box

2. ACTIONS (Refer to Figure 3)

a. **Prioritize Delivery Days** - Press to assign a numerical value to day one of the planning horizon. Priorities for the remaining days will be assigned based on the value assigned to day one (see Figure 7). This is used to ensure that the earliest cargoes are prioritized over the cargoes scheduled later in the planning horizon.

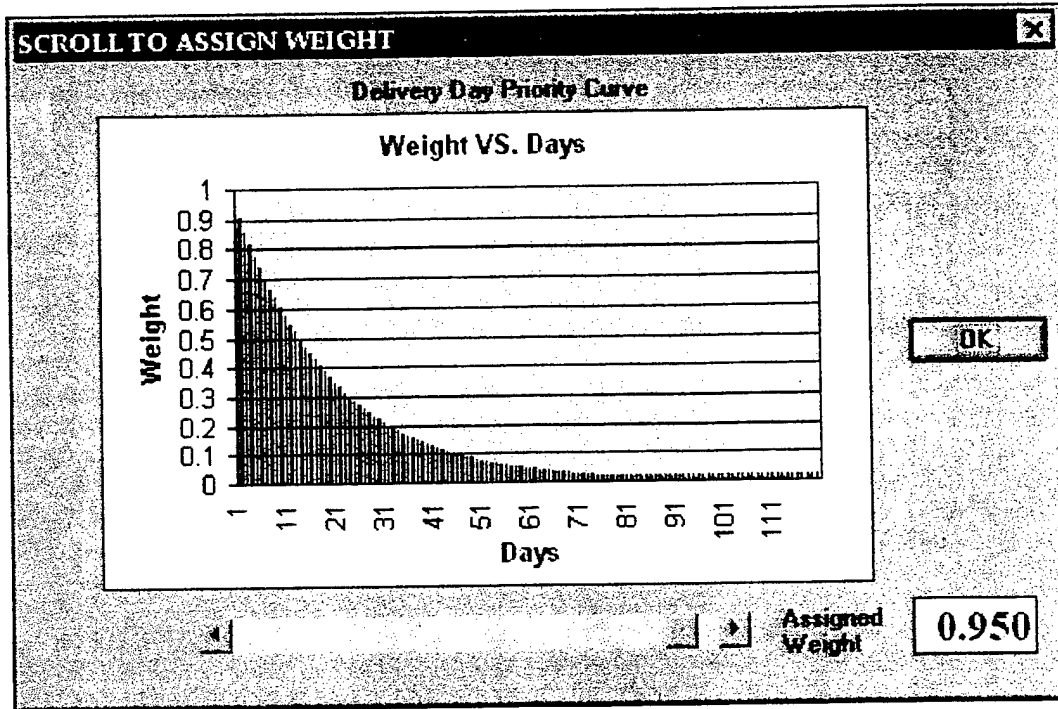

Figure 7. Priority Assignment Dialog Box

The weight (priority) value assigned to day one of the planning horizon (D11) is shown on lower right hand corner. Use the scroll bar to change the Assigned Weight value. The graph depicts the values assigned to all 120 days in the planning horizon (D11- D130).

b. **Run Model** - Press this button to generate a schedule. If the inputs change, the resulting schedules will be different. Do not press this button unless Slate and Prorata have been properly updated, or the solution will be invalid.

c. **Front Page/Exit** - Press this button to go back to the front page and/or exit.

3. OUTPUTS (Refer to Figure 3)

- a. **View Load Port Assignments** - Press to preview a list of possible load ports for each cargo. Only one of the listed load ports will be used in the final schedule.
- b. **View Solution** - Press to view the latest solution. If pressed before a new schedule is generated, it will show the last schedule.
- c. **Print Solution** - Press to obtain a hard copy of the solution.

SLATE INPUT SHEET

		1		2		3		4	
DIR	MONTH								
IANT									
TERMINAL	PROD								
BEAU	F76								
BEAU	JF5	64		50		60		50	80
BEAU	JF8	185		185		175		185	155
CHAS	F76								
CHAS	JF5		90				50		
CHAS	JF8		160			185		185	
JAX	F76	55				40	31		50
JAX	JF5	110							135
JAX	JF8					135			
KWES	F76								
KWES	JF5	40	55			50			50
KWES	JF8	15							
NORF	F76								
NORF	JF5								
NORF	JF8								
PTAM	F76								
PTAM	JF5								
PTAM	JF8			110					
RTEV	F76								
RTEV	JF5								
RTEV	JF8		50						
ROOS	F76								
ROOS	JF5								
ROOS	JF8								
GTMO	F76								
GTMO	JF5								
GTMO	JF8								

Figure 8. Sample Slate Input Sheet with function buttons.

1. **Clear Column** - Press to delete data in the first three columns as the schedule progresses throughout the planning horizon (see Figure 8). The sequence of deletion should be column 1, then column 2, and finally column 3. The deletion sequence should reflect completion of deliveries in each corresponding period. **Caution:** Data deleted in these columns is not recoverable with the Undo function of the Edit Menu. Press Cancel to recover data.

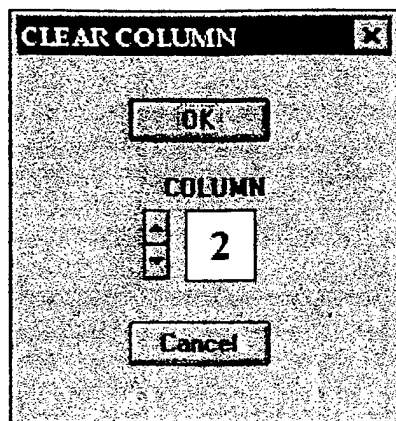

Figure 9 Clear Column Dialog Box
(use spinner control to select column).

2. **Enter Data** - Press prior to any data entry. Data entered should be in MBBLs.
Caution: Use only the white grid area for data entry. Completion of data entry should be followed by pressing the "OK" button.
3. **Move Data** - Press to move data in months 2 - 4 to months 1 - 3 after deliveries for the first month have been completed and the columns have been cleared. **Caution:** If there is data in the first month columns, it will be lost after pressing this button. Data can be recovered if the Cancel button is pressed.
4. **Print Slate** - Press to obtain a hard copy of the slate as shown on the screen.
5. **OK** - Pressing this button generates the data for the optimization model and returns the user to the Main Menu.
6. **Cancel** - Press this button to return to the Main Menu, without changing previous data.
7. **More Ports** - Press to show other ports in the area not visible from current screen.
8. **Return** - Press this button to return to the top of the screen. This button is not visible until the More Ports button has been pressed.

PRORATA INPUT SHEET

SUPPLIER & FUEL LOCATION TYPE		MONTH				
		0	1	2	3	4
COST ARUB	F76	300	300	300	300	300
COST ARUB	JP5					
COST ARUB	JP6	300	300	300	300	300
COST CHRI	F76	300	300	300	300	300
COST CHRI	JP5					
COST CHRI	JP6	300	300	300	300	300
HESS HOUS	F76	294	294	294	294	294
HESS HOUS	JP5	300	300	300	300	300
HESS HOUS	JP6	300	300	300	300	300
PUER YABU	F76	300	300	300	300	300
PUER YABU	JP5					
PUER YABU	JP6					
SHEL DEER	F76					
SHEL DEER	JP5	300	300	300	300	300
SHEL DEER	JP6	300	300	300	300	300

OK

Cancel

ENTER DATA

PRINT PRORATA

Figure 10 Prorata Input Sheet

1. **OK** - Pressing this button generates the data for the optimization model and returns the user to the Main Menu.
2. **Cancel** - Press this button to return to the Main Menu, without changing previous data.
3. **Enter Data** - Press prior to any data entry. The data entered should be in MBBLS.
Caution: Use only the white grid area for data entry. Completion of data entry should be followed by pressing the "OK" button.
4. **Print Prorata** - Press to obtain a hard copy of the prorata as shown on the screen.

A Final Note: This model is designed for the intelligent user. It is intended to be used by those personnel who are familiar with cargo scheduling operations at DFSC. The ability of this model to correct input errors is limited. If the model does not appear to be functioning properly, please check the input data. Incorrect data entries will prevent the model from working properly, resulting in no output or an invalid schedule.

APPENDIX C. VISUAL BASIC SOURCE CODE

The following text is a copy of the VISUAL BASIC source code used to develop the interface to the cargo scheduling model.

```
Declare Function getmoduleusage% Lib "KERNEL" (ByVal hmodule%)

Public UpdateName As String, RegionName As String, RangeName As String
Public NameOfFile As String, ProgName As String, GamsDir As String, WorkDir As
String

Dim CargoNbr As Integer, FirstLeg As Integer, FuelQuantity As Integer
Dim Port As String, Fuel As String, Month As Integer, Quantity As Integer
Dim NbrSl As Integer, FuelCode As Integer

Dim i As Integer, j As Integer, ii As Integer, jj As Integer
Dim Index As Integer, Indice As Integer
Dim NbrRows As Integer, NbrCols As Integer, RowNbr As Integer, ColNbr As Integer
Dim SLRows As Integer, SLCols As Integer, POERows As Integer, POECols As Integer
Dim PRRows As Integer, PRCols As Integer, APOERow As Integer, APOECol As
Integer

Dim CellName As String 'Used in CalculateDepartureDate
Dim StartPorts As String, TotalCargoes As String
Dim AssignedPOE(1 To 50, 1 To 13) As String
Dim CargoArray(1 To 50) As String, PODArray(1 To 50) As String, DayArray(1 To 50)
As String
Dim POEArray(1 To 50) As String, POE_DDayArray(1 To 300) As String
Dim SlateArray(1 To 300) As String, ProRataArray(1 To 300) As String
Dim FilesArray(1 To 12) As String, CounterArray(1 To 12) As Integer

Dim Pin As Object, POEpin As Object, SLPin As Object, PRPin As Object, OmegaPin As
Object

Sub Auto_Open()
    Application.ScreenUpdating = False
    Application.DisplayFullScreen = True
    ThisWorkbook.Sheets("Start Menu").Visible = True
    ThisWorkbook.Sheets("Start Menu").Activate
    Application.DisplayFormulaBar = False
    Application.DisplayStatusBar = False
    For i = 1 To 10
        Toolbars(i).Visible = False
    Next i
```

```

With Application
    .ShowToolTips = False
    .LargeButtons = False
    .ColorButtons = True
End With
With ActiveWindow
    .DisplayGridlines = False
    .DisplayHeadings = False
    .DisplayOutline = False
    .DisplayHorizontalScrollBar = False
    .DisplayVerticalScrollBar = False
    .DisplayWorkbookTabs = False
End With
ThisWorkbook.Sheets("Start Menu").Activate
End Sub

Sub GetGamsDir()
    ' set up list of filters
    Filter = "batch files(*.bat),*.bat,"
    'Display *.* by default
    filterindex = 1
    'Set the dialog box caption
    Title = "Search for and select GAMS.BAT file"
    'get the file name
    FileName = Application.GetOpenFilename(Filter, filterindex, Title)

    If FileName = False Then
        MsgBox "No file was selected "
        Exit Sub
    End If
    'display full path and name of the file
    GamsDir = Left(FileName, Len(FileName) - 9)
    MsgBox "GAMS Directory is " & GamsDir
    Worksheets("START MENU").Unprotect
    ThisWorkbook.Worksheets("START MENU").Range("GAMSDIR").Value = GamsDir
    Worksheets("START MENU").Protect DrawingObjects:=True, Contents:=True,
    Scenarios _
        :=True
End Sub

Sub getWorkdir()
    ' set up list of filters
    Filter = "Excel Spreadsheet(*.xls),*.xls,"
    'Display *.* by default

```

```

filterindex = 1
'Set the dialog box caption
Title = "Select Cargo Scheduling Model's WORKING Directory "
'get the file name
FileName = Application.GetOpenFilename(Filter, filterindex, Title)

If FileName = False Then
    MsgBox "No file was selected "
    Exit Sub
End If
'display full path and name of the file
WorkDir = Left(FileName, Len(FileName) - 12)
MsgBox "Working Directory is " & WorkDir
Worksheets("START MENU").Unprotect
ThisWorkbook.Worksheets("START MENU").Range("WORKDIR").Value =
WorkDir
Worksheets("START MENU").Protect DrawingObjects:=True, Contents:=True,
Scenarios _
:=True
End Sub

Sub GoToStart()
ThisWorkbook.Sheets("START MENU").Visible = True
ThisWorkbook.Sheets("START MENU").Activate
ActiveSheet.Protect DrawingObjects:=True, Contents:=True, Scenarios _
:=True
End Sub

Sub GoToMain()
ThisWorkbook.Sheets("MAIN MENU").Visible = True
ThisWorkbook.Sheets("MAIN MENU").Activate
ActiveSheet.Protect DrawingObjects:=True, Contents:=True, Scenarios _
:=True
End Sub

Sub ShowRegions()
DialogSheets("Regions").Show
End Sub

Sub SlateOKD()
ChangeTime
Application.ScreenUpdating = False
Application.DisplayAlerts = False
Worksheets("Cargoes").Select

```

```
Cells.Select
Selection.ClearContents
Range("A1").Select
AssignCargoNbr
LoadPortAssignment
ClearTemp
GoToMain
End Sub
```

```
Sub SlateCancel()
  ReplaceOldSlate
  ClearTemp
  GoToMain
End Sub
```

```
Sub CopyOldSlate()
  Application.ScreenUpdating = False
  Application.DisplayAlerts = False
  RegionName = Worksheets("Main Menu").Range("A1").Value
  Worksheets("Slate DFR" & RegionName).Range("DATA" & RegionName).Copy
  Worksheets("TEMP").Select
  Range("A1").Select
  Selection.PasteSpecial Paste:=xlValues, Operation:=xlNone, _
    SkipBlanks:=False, Transpose:=False
  Application.CutCopyMode = False
End Sub
```

```
Sub EnterData()
  ActiveSheet.Unprotect
End Sub
```

```
Sub ReplaceOldSlate()
  On Error Resume Next
  RegionName = Sheets("Main Menu").Range("A1").Value
  Application.ScreenUpdating = False
  Application.DisplayAlerts = False
  Sheets("TEMP").Select
  Selection.Copy
  Sheets("SLATE DFR" & RegionName).Select
  Range("C7").Select
  ActiveSheet.Unprotect
  Selection.PasteSpecial Paste:=xlValues, Operation:=xlNone, _
    SkipBlanks:=False, Transpose:=False
  Application.CutCopyMode = False
```

```

ActiveSheet.Protect DrawingObjects:=True, Contents:=True, Scenarios _
:=True
Range("C7").Select
End Sub

```

```

Sub ClearTemp()
Application.ScreenUpdating = False
Application.DisplayAlerts = False
Sheets("TEMP").Select
Selection.ClearContents
Range("A1").Select
End Sub

```

```

Sub ProrataOKD()
AssignProRata
GoToMain
End Sub

```

```

Sub ProrataCancel()
'cut prorata from safe area and paste special values in prorata sheet
GoToMain
End Sub

```

```

Sub UpdateSlate()
UpdateName = "SLATE DFR"
GoToRegion
'copy last slate and paste in safe area for use if option is cancelled
End Sub

```

```

Sub UpdateProrata()
'first step to direct user to a specific region's prorata input table
UpdateName = "SUPPLY DFR"
GoToRegion
End Sub

```

```

Sub SelectRegion()
Select Case DialogSheets("Regions").OptionButtons("OptionLANT")
Case xlOn
RegionName = "LANT"
End Select
Select Case DialogSheets("Regions").OptionButtons("OptionMED")
Case xlOn
RegionName = "MED"
End Select

```

```

Select Case DialogSheets("Regions").OptionButtons("OptionPAC")
    Case xlOn
        RegionName = "PAC"
End Select
Select Case DialogSheets("Regions").OptionButtons("OptionWEST")
    Case xlOn
        RegionName = "WEST"
End Select
Application.ScreenUpdating = False
Application.DisplayAlerts = False
Worksheets("MAIN MENU").Unprotect
Worksheets("MAIN MENU").Range("A1") = RegionName
Worksheets("MAIN MENU").Protect DrawingObjects:=True, Contents:=True,
Scenarios _
    :=True
GoToMain
End Sub

```

```

Sub GoToRegion()
    RegionName = Sheets("Main Menu").Range("A1").Value
    CopyOldSlate
    ThisWorkbook.Sheets(UpdateName & RegionName).Visible = True
    ThisWorkbook.Sheets(UpdateName & RegionName).Activate
    ActiveSheet.Protect DrawingObjects:=True, Contents:=True, Scenarios _
        :=True
    Range("C5").Select
    Range("StartPort").Value = Range("StartPort" & RegionName).Value
End Sub

```

```

Sub AssignCargoNbr() 'assigns a cargo number and window of arrival to the slate
    RegionName = Sheets("Main Menu").Range("A1").Value
    Set Pin = Range("FCCrn" & RegionName)
    RowNbr = Range(RegionName & "FCODE").Rows.Count
    ColNbr = Range(RegionName & "FCODE").Columns.Count
    Set SLPin = Range("SLCnr" & RegionName)
    SLRows = Range("Slate" & RegionName).Rows.Count
    SLCols = Range("Slate" & RegionName).Columns.Count
    Set POEpin = Range(RegionName & "FCREF") 'RANGE IS REGION'S FUEL
SUPPLY CODES
    POERows = Range(RegionName & "SUPCODE").Rows.Count
    POECols = Range(RegionName & "SUPCODE").Columns.Count
    CargoNbr = 0
    NmbrSl = 0
    For j = 1 To ColNbr

```

```

For i = 1 To RowNbr
  If Pin.Offset(i, j) <> 0 Then
    CargoNbr = CargoNbr + 1
    FirstDay = (j * 10) + 1 'To change window size only the value 10 needs to be
                                changed to desired window size
    LastDay = (j * 10) + 10 'in these two equations
    xday = "D" & j & "1*D" & LastDay
    AssignedPOE(CargoNbr, 1) = "C" & CargoNbr 'Cargo Number
    AssignedPOE(CargoNbr, 2) = Pin.Offset(i, 0) 'POD
    AssignedPOE(CargoNbr, 3) = "" & FirstDay
                                'First day of delivery window. Quotes are for text data FirstDay is
numeric
    FuelCode = Pin.Offset(i, j)
    AssignPOE
    CargoArray(CargoNbr) = "C" & CargoNbr & "." & Pin.Offset(i, 0) & "." &
xday
    Range("PODDAT").Offset(0, CargoNbr - 1) = CargoArray(CargoNbr)
    AssignSlate
  End If
Next i
Next j
TotalCargoes = "C1*C" & CargoNbr
Range("NbrCargoes").Value = TotalCargoes
TestAssign
AssignDepartureDates
TestPOE
TestSlate
End Sub

Sub AssignSlate()
  For counter = 1 To SLRows
    If SLPin.Offset(counter, 0) = Pin.Offset(i, 0) Then
      FuelQuantity = SLPin.Offset(counter, j + 1)
      If FuelQuantity > 0 Then
        NmbrSl = NmbrSl + 1
        SlateArray(NmbrSl) = "C" & CargoNbr & "." & SLPin.Offset(counter, 1) & " "
& _
                                FuelQuantity
      End If
    End If
  Next counter
End Sub

Sub AssignProRata()
  Set PRPin = Range("PRCrnr" & RegionName)

```

```

PRRows = Range("ProRata" & RegionName).Rows.Count
PRCols = Range("ProRata" & RegionName).Columns.Count
Indice = 1
For j = 2 To PRCols
  For i = 1 To PRRows
    FuelSupply = PRPin.Offset(i, j)
    If FuelSupply > 0 Then
      Port = PRPin.Offset(i, 0)
      Fuel = PRPin.Offset(i, 1)
      Month = j - 2
      Quantity = PRPin.Offset(i, j)
      ProRataArray(Indice) = Port & "." & Fuel & ".M" & Month & " " & Quantity
      Indice = Indice + 1
    End If
  Next i
Next j
TestProRata
End Sub

```

```

Sub AssignPOE() 'reads slate fuel code range and assigns eligible POE's
  APOECol = 4
  For ii = 1 To POERows
    POECode = POEpin.Offset(ii, 1)
    Select Case FuelCode
      Case 2 ' Choose POE with codes 2,5,6 and 9
        If (POECode = 2) Or (POECode = 5) Or (POECode = 6) Or (POECode = 9)
          Then
            AssignedPOE(CargoNbr, APOECol) = POEpin.Offset(ii, 0)
            APOECol = APOECol + 1
          End If
        Case 3 ' Choose POE with codes 3,5,7 and 9
          If (POECode = 3) Or (POECode = 5) Or (POECode = 7) Or (POECode = 9)
            Then
              AssignedPOE(CargoNbr, APOECol) = POEpin.Offset(ii, 0)
              APOECol = APOECol + 1
            End If
          Case 4 ' Choose POE with codes 4,6,7 and 9
            If (POECode = 4) Or (POECode = 6) Or (POECode = 7) Or (POECode = 9)
              Then
                AssignedPOE(CargoNbr, APOECol) = POEpin.Offset(ii, 0)
                APOECol = APOECol + 1
              End If
            Case 5 ' Choose POE with codes 5 and 9
              If (POECode = 5) Or (POECode = 9) Then

```

```

        AssignedPOE(CargoNbr, APOECol) = POEpin.Offset(ii, 0)
        APOECol = APOECol + 1
    End If
Case 6 ' Choose POE with codes 6 and 9
    If (POECode = 6) Or (POECode = 9) Then
        AssignedPOE(CargoNbr, APOECol) = POEpin.Offset(ii, 0)
        APOECol = APOECol + 1
    End If
Case 7 ' Choose POE with codes 7 and 9
    If (POECode = 7) Or (POECode = 9) Then
        AssignedPOE(CargoNbr, APOECol) = POEpin.Offset(ii, 0)
        APOECol = APOECol + 1
    End If
Case 9 ' Choose POE with code 9
    If (POECode = 9) Then
        AssignedPOE(CargoNbr, APOECol) = POEpin.Offset(ii, 0)
        APOECol = APOECol + 1
    End If
End Select
Next ii
End Sub

Sub AssignDepartureDates()
    Index = 1
    For ii = 1 To CargoNbr
        jj = 4
        While AssignedPOE(ii, jj) <> ""
            DDay = Val(AssignedPOE(ii, 3))
            CalculateDepartureDate
            CDay = DDay - FirstLeg
            POE_DDayArray(Index) = AssignedPOE(ii, 1) & "." & AssignedPOE(ii, jj) & "."
            & "D" & "
                                & CDay & "D" & (CDay + 9)
            jj = jj + 1
            Index = Index + 1
        Wend
    Next ii
End Sub

Sub CalculateDepartureDate()
    Dim POE As String, POD As String
    POE = AssignedPOE(ii, jj)
    POD = AssignedPOE(ii, 2)
    CellName = "FirstLeg" & RegionName

```

```

Range(CellName).Value = "=" & POE & " " & POD
FirstLeg = Range(CellName).Value
End Sub

Sub TestAssign()
Range("TESTER").Offset(0, 0) = "Cargo #"
Range("TESTER").Offset(0, 2) = "Destination"
Range("TESTER").Offset(0, 4) = "Period&Day"
Range("TESTER").Offset(0, 7) = "Assigned Load Ports"
For i = 1 To CargoNbr
    For j = 1 To 12
        Range("TESTER").Offset(i, 2 * j - 2) = AssignedPOE(i, j)
    Next j
Next i
End Sub

Sub TestPOE()
For i = 1 To Index
    Range("POEDAT").Offset(0, i - 1) = POE_DDayArray(i)
Next i
End Sub

Sub TestSlate()
For i = 1 To NmbrSl
    Range("SLDAT").Offset(0, i - 1) = SlateArray(i)
Next i
End Sub

Sub TestProRata()
For i = 1 To Indice
    Range("PRATADAT").Offset(0, i - 1) = ProRataArray(i)
Next i
End Sub

Sub ShipsAvail()
DialogSheets("Ships Available").Show
End Sub

Sub ShipsInfo()
DialogSheets("ShipData").Show
End Sub

Sub ChangeTime()
DialogSheets("L-U TIME").Show

```

End Sub

```
Sub ChangeWeight()  
    DialogSheets("CHANGE WEIGHT").Show  
End Sub
```

```
Sub ShowColumns()  
    DialogSheets("COLUMNS").Show  
End Sub
```

```
Sub ColumnClear()  
    RegionName = Sheets("Main Menu").Range("A1").Value  
    Column = Range("column").Value  
    ActiveSheet.Unprotect  
    Range("COL" & Column & RegionName).ClearContents  
    ActiveSheet.Protect DrawingObjects:=True, Contents:=True, Scenarios _  
        :=True  
End Sub
```

```
Sub MoveSlate()  
    ' On Error Resume Next  
    ActiveSheet.Unprotect  
    RegionName = Sheets("Main Menu").Range("A1").Value  
    Sheets("Slate DFR" & RegionName).Range("Three" & RegionName).Copy  
    Range("C7").Select  
    ActiveSheet.Unprotect  
    ActiveSheet.Paste  
    Application.CutCopyMode = False  
    Application.Goto Reference:=RegionName & "THREE"  
    Selection.ClearContents  
    ActiveSheet.Protect DrawingObjects:=True, Contents:=True, Scenarios _  
        :=True  
    Range("C7").Select  
End Sub
```

```
Sub WriteData()  
    Dim NameOfFile As String  
    Application.ScreenUpdating = False  
    Application.DisplayAlerts = False  
    WorkDir = Range("WORKDIR").Value  
    On Error Resume Next  
    ChDir WorkDir  
    MkDir "gamsdata"  
    NameOfFile = ThisWorkbook.Path & "\gamsdata\Ships.dat"
```

```

Worksheets("gamscode").Range("a26") = "$Include " & NameOfFile
Open NameOfFile For Output As #1
Print #1, Range("shipsdat").Value
Close
NameOfFile = ThisWorkbook.Path & "\gamsdata\LoadPort.dat"
Worksheets("gamscode").Range("a34") = "$Include " & NameOfFile
Open NameOfFile For Output As #2
For i = 1 To POERows
    Print #2, POEpin.Offset(i, 0)
Next i
Close
NameOfFile = ThisWorkbook.Path & "\gamsdata\UnLoadPt.dat"
Worksheets("gamscode").Range("a38") = "$Include " & NameOfFile
Open NameOfFile For Output As #3
For i = 1 To RowNbr
    Print #3, Pin.Offset(i, 0)
Next i
Close
NameOfFile = ThisWorkbook.Path & "\gamsdata\cargo.dat"
Worksheets("gamscode").Range("a42") = "$Include " & NameOfFile
Open NameOfFile For Output As #4
Print #4, Range("NbrCargoes").Value
Close
NameOfFile = ThisWorkbook.Path & "\gamsdata\omega.dat"
Worksheets("gamscode").Range("a67") = "$Include " & NameOfFile
Open NameOfFile For Output As #5
For i = 1 To Range("NbrSelected").Value
    Print #5, Range("pinomega").Offset(i, 0)
Next i
Close
NameOfFile = ThisWorkbook.Path & "\gamsdata\POE.dat"
Worksheets("gamscode").Range("a72") = "$Include " & NameOfFile
Open NameOfFile For Output As #6
For i = 1 To Index
    Print #6, Range("POEDAT").Offset(0, i - 1) ' or USE INSTEAD:
range("POEDAT").Offset(0, i-1)POE_DDayArray(i)
Next i
Close
NameOfFile = ThisWorkbook.Path & "\gamsdata\POD.dat"
Worksheets("gamscode").Range("a77") = "$Include " & NameOfFile
Open NameOfFile For Output As #7
For i = 1 To CargoNbr
    Print #7, Range("PODDAT").Offset(0, i - 1) ' or CargoArray(i)
Next i

```

```

Close
NameOfFile = ThisWorkbook.Path & "\gamsdata\NbrShips.dat"
Worksheets("gamscode").Range("a82") = "$Include " & NameOfFile
Open NameOfFile For Output As #8
Print #8, Range("NbrSelected").Value
Close
NameOfFile = ThisWorkbook.Path & "\gamsdata\Slate.dat"
Worksheets("gamscode").Range("a89") = "$Include " & NameOfFile
Open NameOfFile For Output As #9
For i = 1 To NmbrSl
    Print #9, Range("SLDAT").Offset(0, i) ' or SlateArray(i)
Next i
Close
NameOfFile = ThisWorkbook.Path & "\gamsdata\Prorata.dat"
Worksheets("gamscode").Range("a94") = "$Include " & NameOfFile
Open NameOfFile For Output As #10
For i = 1 To Indice
    Print #10, Range("PRATADAT").Offset(0, i - 1) ' or ProRataArray(i)
Next i
Close
NameOfFile = ThisWorkbook.Path & "\gamsdata\TRQP.dat"
Worksheets("gamscode").Range("a99") = "$Include " & NameOfFile
RangeName = RegionName & "TRQP"
Call ToDisk(NameOfFile)
NameOfFile = ThisWorkbook.Path & "\gamsdata\TRPQ.dat"
Worksheets("gamscode").Range("a104") = "$Include " & NameOfFile
RangeName = RegionName & "TRPQ"
Call ToDisk(NameOfFile)
'Writing GAMS code to the working directory
NameOfFile = ThisWorkbook.Path & "\gamsdata\tsom.gms"
RangeName = "FORMULATION"
Worksheets("GAMSCODE").Activate
Worksheets("GAMSCODE").Range(RangeName).Select
Selection.Copy
Workbooks.Add 'adding another workbook
Selection.PasteSpecial Paste:=xlValues
ActiveWorkbook.SaveAs FileName:=NameOfFile, FileFormat:=xlTextPrinter
ActiveWorkbook.Close
'Return to Main Menu
GoToMain
End Sub

Sub LoadPortAssignment()
    Application.ScreenUpdating = False

```

```

Application.DisplayAlerts = False
NameOfFile = ThisWorkbook.Path & "\gamsdata\loadport.asg"
RangeName = "LOADPORTS"
Worksheets("CARGOES").Activate
Worksheets("CARGOES").Range(RangeName).Select
Selection.Copy
Workbooks.Add 'adding another workbook
Selection.PasteSpecial Paste:=xlValues
Selection.HorizontalAlignment = xlCenter
ActiveWorkbook.SaveAs FileName:=NameOfFile, FileFormat:=xlTextPrinter
ActiveWorkbook.Close
Worksheets("CARGOES").Range("A1").Select
End Sub

```

```

Sub ViewLoadPorts()
LoadPortfile = ThisWorkbook.Path & "\gamsdata\loadport.asg"
appname = "notepad"
appfile = "notepad.exe"

On Error GoTo notrunning
AppActivate (appname)
Exit Sub

```

```

notrunning:
'executed if notepad is not already running
w% = Shell(appfile & " " & LoadPortfile, 1)
End Sub

```

```

Sub DoneInput()
namarea = "main menu"
Application.Goto Reference:=namarea
Range("WORKDIR").Select

End Sub

```

```

Sub ToDisk(NameOfFile)
WorkDir = ThisWorkbook.Worksheets("Start Menu").Range("WORKDIR").Value
' ChDir workdir & "\work"

Application.ScreenUpdating = False
Application.DisplayAlerts = False

Worksheets("DISTANCE " & RegionName).Activate

```

```

Worksheets("DISTANCE " & RegionName).Range(RangeName).Select
Selection.Copy
Workbooks.Add 'adding another workbook
ActiveSheet.Paste
Selection.PasteSpecial Paste:=xlValues
Selection.HorizontalAlignment = xlCenter
Cells.Select
Selection.ColumnWidth = 10
ActiveWorkbook.SaveAs FileName:=NameOfFile, FileFormat:=xlTextPrinter
ActiveWorkbook.Close
Worksheets("DISTANCE " & RegionName).Range("a1").Select
End Sub

```

```

Sub StartGams()
WriteData
GamsDir = Worksheets("Start Menu").Range("GAMSDIR").Value
WorkDir = Worksheets("Start Menu").Range("WORKDIR").Value
ChDir GamsDir
ProgName = GamsDir & "\gams.bat " & WorkDir & "gamsdata\tsom.gms"
xx% = Shell(ProgName, 1)
Do While getmoduleusage(xx%) > 0
y% = DoEvents()
Loop
End Sub

```

```

Sub ExitModel()
GoToStart
ActiveWindow.Close saveChanges:=True
ActiveWorkbook.RunAutoMacros Which:=xlAutoClose
'reconfigure excel on exit
End Sub

```

```

Sub ViewSolution()
'Displays gams solution
GamsDir = Range("GAMSDIR").Value
skedfile = GamsDir & "\tsom.lst"
appname = "notepad"
appfile = "notepad.exe"

On Error GoTo notrunning
AppActivate (appname)
Exit Sub

```

```

notrunning:
    'executed if notepad is not already running
    w% = Shell(appfile & " " & skedfile, 1)
End Sub

Sub PrintSlate()
    Application.ScreenUpdating = False
    Application.DisplayAlerts = False
    RegionName = Sheets("MAIN MENU").Range("A1").Value
    Application.Goto Reference:="PRINT" & RegionName
    With ActiveSheet.PageSetup
        .PrintTitleRows = ""
        .PrintTitleColumns = ""
    End With
    ActiveSheet.PageSetup.PrintArea = ""
    With ActiveSheet.PageSetup
        .LeftHeader = ""
        .CenterHeader = "&A"
        .RightHeader = ""
        .LeftFooter = ""
        .CenterFooter = "Page &P"
        .RightFooter = ""
        .LeftMargin = Application.InchesToPoints(0.75)
        .RightMargin = Application.InchesToPoints(0.75)
        .TopMargin = Application.InchesToPoints(1)
        .BottomMargin = Application.InchesToPoints(1)
        .HeaderMargin = Application.InchesToPoints(0.5)
        .FooterMargin = Application.InchesToPoints(0.5)
        .PrintHeadings = False
        .PrintGridlines = True
        .PrintNotes = False
        .PrintQuality = 300
        .CenterHorizontally = True
        .CenterVertically = False
        .Orientation = xlPortrait
        .Draft = False
        .PaperSize = xlPaperLetter
        .FirstPageNumber = xlAutomatic
        .Order = xlDownThenOver
        .BlackAndWhite = False
        .Zoom = 100
    End With
    Selection.PrintOut Copies:=1

```

```
ActiveSheet.Range("C7").Select
End Sub
```

```
Sub ScrollDown()
ActiveWindow.SmallScroll Down:=15
End Sub
```

```
Sub ScrollUp()
ActiveWindow.SmallScroll Down:=-15
End Sub
```

```
Sub LUTime()
With ThisWorkbook.DialogSheets("L-U TIME")
.TextBoxes("changerate").Caption = .Spinners("spinner 16").Value
End With
End Sub
```

```
Sub AssignWeight()
With ThisWorkbook.DialogSheets("CHANGE WEIGHT")
Weight = .ScrollBars("scroll bar 4").Value / 1000
.TextBoxes("WEIGHT").Caption = Weight
Worksheets("Weights").Range("c1").Value = Weight
Worksheets("GAMSCODE").Range("A84").Value = "SCALAR WEIGHT /" &
Weight & "/"
End With
End Sub
```

```
Sub ColumnData()
With ThisWorkbook.DialogSheets("COLUMNS")
.TextBoxes("Columna").Caption = .Spinners("spinner 5").Value
End With
End Sub
```

LIST OF REFERENCES

- Ahuja, R.K., T.L. Magnanti and J.B. Orlin, Network Flows: Theory, Algorithms, and Applications. Prentice Hall. p. 177. 1993.
- Bausch, D.O., G.G. Brown and D. Ronen. *Consolidating and Dispatching Truck Shipments of Mobil Heavy Petroleum Products*. Interfaces, 25(2). 1995.
- Bochert, J., Director, Tanker Distribution Branch, Defense Fuel Supply Center. Interview with J. Strength. November, 1995.
- Briskin, L.E., *Selecting Delivery Dates in the Tanker Scheduling Problem*. Management Science, 12B, pp. 224-233. 1966.
- Brooke, A., D. Kendrick and A. Meeraus, GAMS: A User's Guide, Scientific Press, 1992.
- Brown, G.G., G.W. Graves, and D. Ronen. *Scheduling Ocean Transportation of Crude Oil*. Management Science, 33, pp. 335-346. 1987.
- Dantzig, G.B. and D.R. Fulkerson, *Minimizing the Number of Tankers to Meet a Fixed Schedule*. Naval Research Logistics Quarterly, 1, pp. 217-222. 1954.
- Defense Fuel Supply Center Public Affairs Office. Defense Fuel Supply Center, Your Energy Supplier. Fort Belvoir, VA, pp. 9-11. 1995.
- Fisher, M.L. and M.B. Rosenwein. *An Interactive Optimization System for Bulk-Cargo Ship Scheduling*. Naval Research Logistics, 36, pp. 27-42. 1989.
- Laderman, J., L. Gleiberman and J.F. Egan, "Vessel Allocation by Linear Programming," Naval Research Logistics Quarterly, 131, pp. 315-320. 1966.
- McKay, M.D. and H.O. Hartley, "Computerized Scheduling of Seagoing Tankers," Naval Research Logistics Quarterly, 21, pp. 255-264. 1974.
- Mitra, G., C. Lucas, and S. Moody, "Tools for Reformulating Logical Forms Into Zero-One Integer Programs," European Journal of Operations Research, Vol. 72, pp. 262-270, 1994.
- Ronen, D. *Dispatching Petroleum Products*. Operations Research, 43, pp. 379-387. 1995.

INITIAL DISTRIBUTION LIST

1. Defense Technical Information Center.....2
8725 John J. Kingman Rd., STE 0944
Ft. Belvoir, VA 22304-6145
2. Dudley Knox Library.....2
Naval Postgraduate School
411 Dyer Rd.
Monterey, CA 93943
3. Prof. D. Boger, Code OR/Bo.....1
Department of Operations Research
Naval Postgraduate School
Monterey, CA 93943-5101
4. CDR B. Vassian, Code OR/Va.....1
Department of Operations Research
Naval Postgraduate School
Monterey, CA 93943
5. LT Jorge Quiroga.....2
581 B Wilkes Lane
Monterey, CA 93940
6. LT J.T. Strength.....2
5132 County Road 222
Lanett, AL 36863
7. CAPT F.C. Petho, Code OR/Pe.....1
Department of Operations Research
Naval Postgraduate School
Monterey, CA 93943
8. Prof. D. Schrady, Code OR/Sc.....1
Department of Operations Research
Naval Postgraduate School
Monterey, CA 93943-5101
9. Defense Logistics Studies Information Exchange.....1
U.S. Army Logistics Management Center
Fort Lee, VA 23801

- 10. Deputy Chief of Naval Operations (Logistics).....1
Attn: CDR Robert Drash (N422C)
2000 Navy Pentagon
Washington, DC 20350-2000

- 11. CPT Stan Olson.....1
Director, Tanker Distribution Branch
Defense Fuel Supply Center
8725 John J. Kingman Rd Ste 4950
Fort Belvoir, VA 22060-6222