

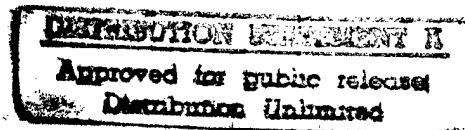

DCS CORPORATION

**FINAL REPORT**

**DEVELOPMENT OF TECHNOLOGY FOR  
MICROWAVE ARRAYS**



**CONTRACT N00014-92-C-2265  
CDRL D004**

22 January 1997

**SUBMITTED TO:  
NAVAL RESEARCH LABORATORY  
WASHINGTON, D.C. 20375-5000  
ATTN: CODE 6800**

1330 BRADDOCK PLACE  
ALEXANDRIA, VA 22314  
TELEPHONE: (703) 683-8430

19970123 034

# DISCLAIMER NOTICE

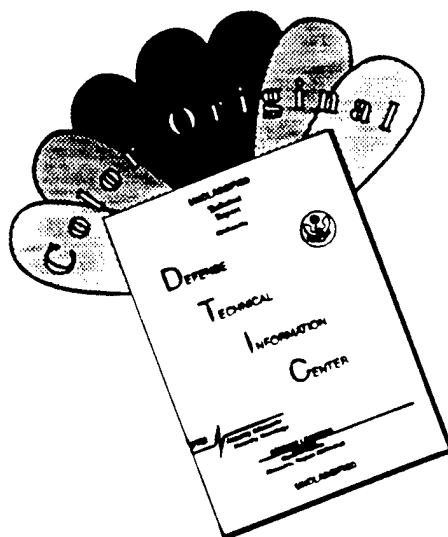

THIS DOCUMENT IS BEST QUALITY AVAILABLE. THE COPY FURNISHED TO DTIC CONTAINED A SIGNIFICANT NUMBER OF COLOR PAGES WHICH DO NOT REPRODUCE LEGIBLY ON BLACK AND WHITE MICROFICHE.

## TABLE OF CONTENTS

|            |  |    |
|------------|--|----|
| 1.0        | TASK 1: MATERIAL TECHNOLOGY .....  | 1  |
|            | 1.1 Gallium Arsenide Substrates.....   | 1  |
|            | 1.2 Other Materials .....  | 2  |
| 2.0        | TASK 2: SEMICONDUCTOR DEVICES AND CIRCUITS .....                             | 2  |
|            | 2.1 MIMIC Program.....   | 3  |
|            | 2.2 MAFET Program .....  | 4  |
|            | 2.3 High Density Microwave Packaging (HDMP) Program.....                     | 6  |
|            | 2.4 Airborne Shared Aperture Program (ASAP) .....                            | 7  |
|            | 2.5 Active Electronically Scanned Arrays (AESA) .....                        | 8  |
|            | 2.6 Other Tasks .....  | 8  |
| 3.0        | TASK 3: VACUUM ELECTRONICS .....   | 9  |
|            | 3.1 MPM/MMPM Program .....   | 10 |
|            | 3.2 MMACE Initiative .....   | 11 |
|            | 3.3 High Performance Millimeter Wave Amplifiers.....                         | 12 |
|            | 3.4 Affordable Performance.....  | 12 |
|            | 3.5 Vacuum Microelectronics .....  | 12 |
|            | 3.6 Supporting Technology .....  | 12 |
| 4.0        | TASK 4: MANUFACTURABILITY .....  | 12 |
|            | 4.1 DALP Program.....  | 14 |
|            | 4.2 Microwave Quality Assurance Testing and Reliability Assessment.....      | 15 |
| 5.0        | TASK 5: TECHNOLOGY INSERTION .....   | 22 |
|            | 5.1 Maritime Avionics Subsystems and Technology (MAST).....                  | 22 |
|            | 5.2 Anti-Submarine Warfare.....  | 25 |
|            | 5.3 ECCM Communications & Electronic Protection (EP) Communications ...      | 26 |
|            | 5.4 F-18 Avionics.....   | 27 |
|            | 5.5 Rapid Prototyping of Application Specific Signal Processors (RASSP)..... | 28 |
|            | 5.6 Smart Weapons .....  | 29 |
|            | 5.7 Advanced Technology Investigations .....                                 | 30 |
|            | 5.8 H-53 Systems Engineering.....  | 31 |
|            | 5.9 Navy MAST Mounted Sight (NMMS) .....                                     | 32 |
|            | 5.10 Miscellaneous Technology Transition Activities.....                     | 33 |
|            |  |    |
| Appendix A | Microchip Inspection Photographs   |    |
| Appendix B | Index of DCS Deliverables  |    |
| Appendix C | Financial Tracking Charts  |    |

## 1.0 TASK 1: MATERIAL TECHNOLOGY

Material technology studies conducted by DCS during the performance period of this contract were focused mainly on gallium arsenide substrates because of the close coupling with the MIMIC program. We were able to determine the influences of gallium arsenide substrate quality on the performance and yield of monolithic integrated circuits. During the course of the MIMIC Program, the availability of device-quality gallium arsenide was significantly enhanced.

DCS devoted a portion of the material technology effort to the assessment of other semiconductor substrates as well as circuit level substrates and packaging materials. Much of this work was performed in connection with the High Density Microwave Packaging (HDMP) program.

### 1.1 Gallium Arsenide Substrates

During the course of the MIMIC program, we continuously assessed the status of gallium arsenide substrate material development. The MIMIC program objectives placed significant demands on material development and refinement since efficient gallium arsenide integrated circuit processing is highly dependent on the quality and uniformity of the substrate material. The cost, yield, throughput and cycle time goals of MIMIC were all dependent on gallium arsenide starting material. The yield analyses we performed pointed toward corrective actions related to physical properties of the substrate. Material quality was correlated with device/circuit performance.

DCS placed significant emphasis on wafer qualification since one of the MIMIC goals was to develop a plan for full vendor qualification by the end of Phase 2. We were able to verify that test results by material vendors and the MMIC manufacturers were in good agreement. Most of the MIMIC contractors were able to move material qualification testing to the vendors with the exception of the implant activation test. All physical and surface quality parameters are now defined by a common substrate specification with verification tests being performed by the boule vendor, this accomplishment has moved GaAs much closer to silicon in material maturity.

Epitaxial substrates are, however, less mature than ion implanted substrates even though there has been recent progress. A few years ago, epitaxial vendors could not provide the MMIC manufacturers with all the data necessary to proceed with the processing of PHEMT devices. The qualification of PHEMT material typically requires the fabrication of FET devices for DC testing. MMIC manufacturers must take into account the differing indium compositions of InGaAs channels in wafers from different vendors. With the uniformity of gallium arsenide PHEMT material improving, the following accomplishments are cited:

- X-ray diffraction, photoluminescence and Polaron characterization tests have been developed and are being used to screen PHEMT material (these tests permit more rapid qualification of new epitaxial material vendors).
- Ability to adjust growth conditions to match material from different vendors.
- More accurate specification and control of the indium composition in the InGaAs channel.

DCS conducted a thorough review of the draft Raytheon/TI Joint Venture's Incoming Wafer Materials Qualification Specification required by the MIMIC program. We recommended that it be approved.

DCS has monitored the Air Force Title III program from its planning phase to the present. We prepared an overview of the program as it was being formulated in order to keep NRL apprised of its content and goals as well as encouraging the Navy to provide technical input to the Air Force. After contracts were awarded, we continued to keep NRL informed by providing overview reports on the progress being achieved by the three Title III contractors: Litton-Airtron, M/A-COM, and American Xtal Technology. Japan still dominates the worldwide GaAs substrate market place (six Japanese companies produce GaAs substrates). Our assessments indicate that (1) Litton-Airtron is the second largest worldwide supplier. They are reducing processing time and attempting to penetrate the Japanese and European markets; (2) M/A-COM has pursued a "substrate performance" approach to the market place and is making yield improvements (lower imperfections, better electrical properties); (3) AXT is the world leader for vertical gradient freeze technology and is increasing production throughput; and, (4) the title III program is achieving its goals.

DCS also tracked the cost of 3 and 4 inch wafers (starting material) as well as the transition of the MMIC industry from 3 to 4 inch wafers. Our analyses indicated that the cost of GaAs starting material is less than 20% of the cost of a fully processed wafer while the cost of processed wafers has been reduced by 50% over the past five years.

## 1.2 Other Materials

DCS expanded its material assessments to include materials other than semiconductor substrates such as silicon, gallium arsenide, indium phosphide, silicon carbide, and heterostructure materials. We have recently initiated assessments of various non-semiconductor substrate materials and packaging materials. We have access to the Georgia Institute of Technology Microwave Packaging Materials Database and other material data sources to aid in our assessment of various non-semiconductor substrate and packaging materials in order to provide recommendations on the application of these wide range of materials.

## 2.0 TASK 2: SEMICONDUCTOR DEVICES AND CIRCUITS

Work performed by DCS under this task was principally directed toward the Microwave/Millimeter Wave Monolithic Integrated Circuits (MIMIC) Phase 2 and Phase 3 programs and the Microwave and Analog Front End Technology (MAFET) program. We also performed work in connection with the Airborne Shared Aperture Program (ASAP), the High Density Microwave Packaging (HDMP) program, and the Navy's Active Electronically Scanned Array (AESA) technology development. In addition to these major efforts, we also completed several special task assignments associated with the power module portion of NRL's Vacuum Electronics Initiative as well as other technical task assignments not specifically tied to the programs cited here.

## 2.1 MIMIC Program

We were able to put our microwave/analog semiconductor device and circuit experience to good use in providing engineering support to NRL in connection with the various MIMIC program developments. The MIMIC program was quite intensive in its reporting requirements. Much of our effort was directed toward the review of the various plans and reports submitted by the Navy MIMIC contractors. Many plans, reports, and specifications required approval/disapproval by the government. DCS reviewed the following MIMIC documents and provided technical recommendations to NRL:

- Business Plans
- Brassboard Development and Demonstration Plans
- Brassboard Demonstration Reports
- Interim Status Reports
- Quality Assurance and Qualification Plans
- Process Line Validation Plans
- Process Line Validation Reports
- Process Line Status Reports
- Process Demonstration Plans
- Process Demonstration Reports
- Advanced Technology Development Plan
- Design System Functional Description Report
- Chip and Module Test Plans
- Chip and Module Test Reports
- Task 3 Test Plans
- Advanced Technology Wafer Qualification Specification
- Reliability Test Fixture Specification
- Incoming Wafer Material Qualification Specification
- Test Fixture Compatibility Test Requirements Report
- Various Cost Reports (CFSR, CPR, C/SSR, CWBS)
- Project Planning/Actual Progress Chart
- Agendas/Minutes/Presentation Material

This list of documents indicates the broad scope of our review activities. Many plans and reports required multiple submissions related to each technology and each process. Some documents were submitted periodically; others required updates. Our intensive review of the MIMIC documentation along with the technical recommendations to NRL provided a valuable service in directing and expediting the Navy's MIMIC program.

DCS submitted monthly reports to NRL on the progress of Navy MIMIC Phase 2 and Phase 3 contractor activities. We also maintained an extensive database relative to the various data deliverables required by the contractors. This data provided the basis for the Navy's MIMIC monthly report to DARPA.

DCS participated in all the major MIMIC program reviews such as the yearly executive review, periodic technical reviews, and the annual MIMIC conference. Subsequent to these reviews, we prepared summary reports which included side-by-side comparisons of the work performed by each of the three Phase 2 contractor teams. We compared each contractor's performance in the following categories:

- Business Plan
- Brassboards
- Demonstrators
- Other Insertions
- Chip Fabrication
- Chip/Wafer Manufacturing
- Design Technology
- Database Development
- Testing Technology
- Advanced MMIC Technology

DCS monitored progress under the Army's MIMIC Phase 1 extension program which ran concurrently with the MIMIC Phase 2 program. The Army contract with ITT called for development of power MMICs for microwave T/R modules. DCS attended reviews at ITT (Nutley, NJ and Roanoke, VA) and kept NRL informed with summary technical reports.

In addition to the technical assessments performed in connection with the MIMIC program, we also provided other programmatic functions which included:

- Preparation of draft technical correspondence to contractors.
- Preparation of and corrections to distribution and invitation lists.
- Preparation of presentation material.
- Preparation of draft technical reports to DARPA.

## 2.2 MAFET Program

The MAFET program is a follow-on to the MIMIC program and DCS participated in all phases from its inception through the initiation of the three contractual thrust areas. We participated in the DARPA Post-MIMIC Workshop held in January 1993 and the Navy Post-MIMIC Workshop held in May 1993. These workshops and subsequent meetings between the Services and DARPA resulted in defining the MAFET program. Our participation in the MAFET planning process provided technical recommendations to NRL regarding the following issues:

- Post-MIMIC (MAFET) Model
- MAFET program direction
- Statement of Work factors
- MAFET priorities

- Scope/duration
- Materials/substrates
- MMICs
- Packaging/interconnects
- MMIC design
- MMIC processing
- Manufacturing/testing
- Reliability/quality assurance
- Quasi-Optics/Photonics
- Benchmarking demonstrations

We prepared a white paper which summarized the statement of work factors considered to be important in defining a program which would build on the results achieved under the MIMIC program. A subsequent white paper provided more specific technical recommendations in regard to the following issues:

- Design environment
- MAFET program emphasis
- Primary vs. Support Technology thrusts
- MCA-level vs. chip-level developments
- Microwave vs. Millimeter Wave developments
- Effect of the predicted MMIC industry shakeout on the MAFET program definition
- Use of BAA vs. RFP as the MAFET procurement vehicle

The MAFET Program Definition document was prepared by DARPA and sent to industry for comments. Once comments were received, DCS assisted NRL in preparing the Navy response to key issues raised by industry. This information was subsequently provided to NAVAIR for presentation to DARPA.

DARPA solicited proposal abstracts from industry and academia. DCS personnel were tasked to review all 108 abstracts submitted for MAFET Thrust Area #2 (Component/Product Development) and provide technical comments to NRL. At the request of NRL, DCS reviewed selected Thrust Area #2 proposals and provided technical comments to NRL. We also provided technical and programmatic recommendations for reducing the scope of several MAFET proposals to match DARPA funding profiles.

DCS prepared a MAFET overview presentation for use by NRL personnel. This technical presentation describes MAFET Thrust #1 and #2. A second overview presentation was also prepared for higher level briefings. We assisted NRL in their response to DARPA for MAFET figures of merit for benchmark achievements under the program.

A DCS representative attended the MAFET Thrust #3 Bidders' Brief. A report was prepared for NRL covering the proceedings of the Bidders' Brief and to inform NRL regarding

the change in technical directions articulated by DARPA. The new goals of the MAFET Thrust #3 program are:

- (1) Low-cost, high performance microwave technology (50 times improvement over the present performance/cost)
- (2) Millimeter wave technology (10 times improvement in performance)
- (3) MAFET technology demonstrations

DCS provided support to NRL in their evaluation of the MAFET Thrust #3 proposals by providing technical recommendations to the Navy's evaluation team.

DCS participated in all MAFET program reviews. We participated in the MAFET Thrust #1 and #2 kick-off review in August 1995. Subsequent to this meeting, we prepared a report which provided the following technical information for each of the sixteen contractor teams:

- Program Description
- Program Goals
- Approach
- Strengths
- Weaknesses
- Assessment

DCS participated in the six-month executive reviews in March 1996 as well as numerous on-site reviews. Summary reports of these reviews were published and provided to NRL. In addition to these major and on-site reviews, we have an on-going task of assessing all the contractors monthly and interim reports submitted under the Navy's MAFET program. Based on this task, we have submitted significant accomplishment reports to NRL for submission to DARPA. These submissions were in response to DARPA's request that technical breakthroughs and major accomplishments be reported as they occur.

### 2.3 High Density Microwave Packaging (HDMP) Program

The HDMP program, like MIMIC and MAFET, is another DARPA/Tri-Service program. It is a two-phase program consisting of a Primary phase and Support Technology phase. Each of the three primary phase contractors (TI, Hughes, and Westinghouse) are developing 2 x 2 tile subarrays suitable for use as building blocks for the next-generation aircraft and space-based phased array radars. The four support technology contractors are: Georgia Tech Research Institute (developing a packaging materials database), M/A-COM (developing coatings for GaAs MMICs), HP EEsosf, and Compact Software (developing CAD tools for the design of high density microwave packages).

DCS provided analyses during the planning stages of the HDMP program. We analyzed the results of studies performed prior to initiating the actual HDMP program. These studies helped to define HDMP. We analyzed the proposals for the studies submitted by ANRO, Ball, ERIM, SAIC, Westinghouse, and the University of California. These studies defined future space and airborne phase array technology needs, the technology innovations and manufacturing

processes which would result in the lowest cost and widest applicability, a technology development plan and associated risks.

When the HDMP program was initiated, we provided technical and programmatic support to the Navy Source Selection Evaluation Board and maintained the HDMP proposal library. DCS was tasked to review the proposals submitted under the primary phase of the HDMP and provide technical comments to the evaluation team. A technical assessment of the fifty-five proposals received under the support technology phase was performed and submitted to NRL.

During the course of the HDMP program, continuing technical progress assessments were performed and summary reports submitted to NRL. Following the formal reviews held by DARPA, technical reports covering the following subjects were submitted:

- Interconnects/Tile Concept/Subarray Concept
- Cost/Cost Modeling
- Proposed Insertions/Market Forecast
- HDMP CAD/Design Tools
- Assembly/Integration/Test
- Interactions
- Risks
- Assessment

Additional technical assessments were provided for the technology support contracts. These assessments highlighted contractor accomplishments and provided an overall assessment of their progress.

#### 2.4 Airborne Shared Aperture Program (ASAP)

The Airborne Shared Aperture program (ASAP) was sponsored by the Naval Air Systems Command and directed by the Naval Air Warfare Center (Warminster, PA). DCS provided technical and engineering support to ASAP in conjunction with several NRL scientists and engineers.

DCS provided technical consultation in connection with the ASAP proposal evaluation. This consultation was directed primarily toward the development of broadband transceiver modules. A cost-yield trade-off analysis was performed to compare HBT, HEMT, and FET approaches to the objective specifications of the ASAP modules. This analysis defined cost, yield, size, performance, and power consumption of the various approaches. A DCS conducted assessment of GaAs chip cost indicated that a chip set (11 chips) for the ASAP T/R module would cost \$840 in 1992 dollars.

We followed the progress of two specific NRL development contracts which had direct bearing on ASAP. These contracts were the Wideband Phase Shifter development at Texas Instruments and the Broadband H/V Antenna Switch development at M/A-COM. We kept the NAWC Program Manager informed as technical developments progressed. We attended the

ASAP technical review meetings at TI and Westinghouse and provided assessment reports to NRL, NAWC, and NAVAIR.

## 2.5 Active Electronically Scanned Arrays (AESA)

Although the DARPA AESA program never materialized, DCS actively participated in the planning phase. Under the present Navy MAFET Thrust #2 program the Raytheon/TI Joint Venture is developing this technology under a program titled Technologies for Wideband AESAs. DCS participated with the Navy's team in meetings and discussions with industry and DARPA in an attempt to initiate a program directed toward AESA technology development. AESA technology is of key importance to the military even though there appears no commercial applications to support the development and production of this technology.

Subsequent to DARPA AESA planning, a Navy Broadband AESA Device Workshop was held at NRL in November 1994. DCS provided both technical and programmatic assistance to NRL and NAWC in organizing this workshop.

DCS was an active participant in the technical discussions conducted during the workshop. Upon completion of the workshop, we prepared an overall technical assessment of the proceedings which covered the following issues:

- Institution of a bottom-up technology "push" approach.
- Importance of broadband AESA technology to the military.
- Suggestion that the Advisory Group on Electron Devices (Working Group A) schedule a Special Technical Area Review on AESA technology.
- Suggestion to provide a clear choice between MPMs and all-solid-state approaches for specific applications.
- Control component development.
- Need for manufacturing science programs since price tag can be a "show stopper".
- Chip compaction & higher levels of integration.
- Power added efficiency.
- Plastic encapsulated components and Reliability without Hermeticity (RwoH).
- Flexible manufacturing lines.

## 2.6 Other Tasks

In addition to the foregoing programs, DCS responded to other Task 2 assignments requested by NRL. We performed several studies associated with devices and circuits that were not directly connected to the programs discussed above. The studies included the following:

- (1) A study of the availability of various GaAs MMIC power amplifiers below 6 GHz. Our extensive library of technical data provided much of the source material for this study.

- (2) An analysis of the state-of-the-art of PHEMT technology as it relates to the Navy's Cooperative Engagement Capability.
- (3) Analyses of MMIC cost models, yield calculations, and MMIC market projections.
- (4) Determination of figures of merit (in watts per pound) for C-, X-, and Ku-band transceiver modules.
- (5) Assessment and recommendations in regard to revived Navy interest in EBS technology.
- (6) Assessments of the status of plastic encapsulated microcircuits and their use by the military.
- (7) Assessment of the state-of-the-art of power-added efficiencies for MESFETs, HBTs, and PHEMTs.
- (8) Analyses of several technology export control, jurisdiction, and public release cases along with appropriate recommendations to the Navy.
- (9) DCS's Ron Wade has published the monthly WADEBRIEF which is distributed to various NRL representatives in the Electronics Science and Technology Directorate. The WADEBRIEF contains information which is of interest to NRL engineers and scientists. It covers subjects such as:
  - S&T budgets/policy
  - Microwave technology
  - Microwave business/trends
  - Semiconductor business/trends
  - Semiconductor materials
  - Semiconductor devices/circuits
  - Control components
  - Lithography
  - Technology transfer
  - Military and commercial electronics
  - Education & the profession

### **3.0 TASK 3: VACUUM ELECTRONICS**

The development of critical vacuum electronics technology has been formalized into a continuing Tri-Service program, administered by NRL, to extend the performance of microwave and millimeter wave vacuum tube devices, to develop vacuum tube materials and technology, and to promote vacuum tube manufacturing capabilities. This technology program provides new affordable microwave/millimeter wave vacuum tube capabilities to help meet the Navy's systems

requirements. Navy applications include EW/ECM, expendable decoys, electronic support measures, stand-off jamming, anti-radiation missile guidance, ship defense illumination and high-resolution millimeter wave airborne tracking and imaging radar.

During the 1992 to 1996 time period, DCS has provided technical assistance to NRL for the following projects: Microwave Power Module (MPM)/Millimeter Wave Power Module (MMPM); Microwave and Millimeter-Wave Advanced Computational Environmental (MMACE); High Performance Millimeter Wave Devices; Affordable Performance; Vacuum Microelectronics; and Supporting Technology. These developmental efforts will continue into the next century. The Vacuum Electronics program is structured to capitalize on the synergism of these projects which share a common technological and scientific base and meet vacuum electronics needs of the Tri-Services, DARPA, NASA, and other U.S. Government Departments and Agencies.

DCS representatives attend the Vacuum Electronic Annual Review at the biennial Microwave Power Tube Conference or at the International Conference on Plasma Sciences. Each contractor presents a progress review during these meetings and DCS submits a compendium of each report to Code 6840. DCS is responsible for notifying Government and industry personnel involved in the Tri-Service program for scheduled reviews and industry meetings. DCS compiled a list of all personnel that are, or have been involved in all the vacuum electronics programs with their addresses, phone/fax numbers, and if available, their e-mail numbers.

### 3.1 MPM/MMPM Program

The MPM and MMPM development initiatives take full advantage of combining the advances made in solid state technology under the DARPA sponsored Tri-Service MIMIC/MAFET programs and the evolutionary advances made in materials, design, and manufacturing of vacuum electronics devices. The MPM is capable of providing 50 to 100 watts over bandwidths suitable for EW systems. In addition to being utilized in the design of new systems, it is also being incorporated into older equipment giving these systems new life as well as updated technologies. The use of the MPM in the AN/SLQ-32 is an example of a form, fit, and function retrofit which takes advantage of the unique improvements which can be achieved through the use of an integrated MMIC driver and vacuum electronic booster. The MPM will be used similarly in aerial targets as well as the new Tier II and Tier III UAV's.

Based on our in-depth experience, we performed analyses to determine the types of applications for which the MPM/MMPM would be most suitable. DCS provided NRL with recommendations where MPM/MMPM technology is a strong contender for inclusion in emerging systems and where technology improvements or developments must be focused in order to meet the future systems requirements.

DCS has been involved in various areas of support encompassing scientific, technical, and programmatic disciplines related to the several MPM programs. Programmatic support provided includes preparing meeting agendas, compiling list of attendees, hosting MPM and MMPM meetings and attending vendor demonstrations of these products. We have gathered

information pertaining to the application of these devices to UAVs, and ECM upgrades. DCS has been responsible for maintaining a funding profile on each of the contracts in this program to permit the Program Manager to allocate funding resources when needed which results in maintaining an even contractual program with no gaps in scheduled work. Reports are reviewed, summarized, and arranged by attributes for future reference by the Program Manager and the contractors notified when they miss a monthly and/or quarterly report.

### 3.2 MMACE Initiative

The MMACE initiative was inaugurated in 1991 to aid power tube manufacturers during the development of future vacuum electronic devices for DoD and commercial uses. This initiative will be of use to other design houses in the pursuit of new technologies. The MMACE project is pursuing an integrated approach by developing an advanced design environment for power tubes based on generic and application specific software that is closely coupled to common data and standards. This project is resulting in the development of a comprehensive, integrated computer aided design (CAD) capability for designing vacuum electronic devices with reduced development time, cost, and risk while enhancing reliability and performance. Successful conclusion of the MMACE project will result in decreasing production costs and rapid insertion of the latest technological advances to meet rapidly evolving systems requirements.

Phase I of the MMACE was completed in 1993 with the successful development of a MMACE prototype design framework. The on-going three year Phase II effort was begun in 1994 to build on the lessons gained from Phase I and to develop a more comprehensive and improved implementation of the design environment. The 3 year Phase III program will focus on developing 3-D simulation, developing advanced design tools for vacuum electronics (VE) and extending the framework and tool set to accommodate VE manufacturing. There is also a very high probability that other technologies could make use of the framework, such as antenna systems design and the microwave systems design using semiconductor technologies.

DCS played a pivotal role in assisting the MMACE program manager in planning and executing of Research and Engineering Framework (REF) during Phases I and II. DCS was a key partner with NRL in bringing together U.S. Government and power tube industry officials in the establishment of a larger user base to utilize the 2-D design system in vacuum electronics design efforts. DCS also reported the technical progress, schedule of accomplishments, resource allocation, and expenditures of individual contractor efforts.

DCS has acted as recording secretary for the MMACE program and helped prepare the agenda for meetings, notified attendees, and distributed minutes after each meeting. In 1994 DCS hosted a workshop in San Francisco to define the Phase II program which is scheduled for completion in March of 1997. The follow-on pre-planning Phase III program documentation was prepared.

Several software tool development contracts were let by NRL, Air Force, the Crane Division of NSWC, and the Army. These tools will be submitted to the Phase III contractor for addition to the REF. A DCS subcontractor is on contract to assist the microwave tube vendors in

putting their own tools (those considered to be proprietary) into the REF at each manufacturers plant. Phase III will concentrate on developing 3-D codes to further enhance the development capabilities. Over the last three years, several DCS subcontractors have supplemented this program and help prepare a new way to design microwave and millimeter wave tubes prior to building the devices.

### 3.3 High Performance Millimeter Wave Amplifiers

The HPMMW program is being focused on Fast Wave Devices at millimeter wave frequencies for high powered radars. These devices utilize over-moded circuits which permit much larger than conventional slow-wave circuits to achieve high power and modest radar bandwidth. With DCS's support, NRL scientists are in contact with other Government radar designers and there is a concerted effort underway to develop a W-Band high power device for future shipboard radar.

### 3.4 Affordable Performance

DCS has supported this program by attending review meetings and providing summary progress reports. This portion of the VE program has limited funding resources and no new work is being undertaken. CFA modeling being done by SAIC will be supported by a subcontract from DCS. Grants to Northeastern University and the University of Michigan for CFA design will continue to support the Aegis SPY-1 radar program. During 1995, NRL supported the first Crossed Field Amplifier International Conference at the University of Michigan via a DCS subcontract. Over 80 participants from industry, six different universities, U.S. Government Laboratories, and five foreign countries attended this three day workshop.

### 3.5 Vacuum Microelectronics

The first success of this type of device is beginning to be seen in flat panel displays for aircraft. The Government continues to support development in the effort to design a small FEA cathode for microwave tubes. The outcome will be seen in the further reduction in size and weight of the small power boosters used in the MPM and MMPMs. DCS support for this program is minimal and is given on a per-request basis.

### 3.6 Supporting Technology

This program is supporting the search to replace highly toxic materials as well as materials that are in short supply due to reliance on foreign sources. A program to develop high-temperature super conductive magnets is also under way. DCS provides the program managers of programs under this project with needed contractor information and insures that funding schedules are maintained to permit work to proceed on an uninterrupted basis.

## 4.0 TASK 4: MANUFACTURABILITY

This task was directed primarily toward the achievement of manufacturable and affordable microwave arrays. Our work under this task was synergistic with the work under Task

2 (Semiconductor Devices and Circuits). The MIMIC, MAFET, ASAP, HDMP, and AESA programs were all partially directed toward the goal of achieving manufacturable/affordable microwave arrays.

Improved manufacturability of microwave arrays requires, first order, manufacturable device and circuit technologies. This was a primary thrust under the MIMIC and MAFET programs; Low cost T/R modules was a primary goal of the ASAP program; Advanced subarray packaging technology was the key to success under the HDMP program; and advanced technology for affordable airborne and space-based microwave arrays was the goal of the AESA program.

Our assessments of these development programs indicates that the following are key factors for achieving affordable microwave arrays:

- Increased levels of integration/reduced parts count
- Increased component/circuit yields
- Advanced manufacturing techniques
- Elimination of wirebonds
- Increased automation
- Simpler/less expensive packaging
- Statistical process control/manufacturing techniques
- Increased testing speed/elimination of testing
- More accurate/efficient design tools

Our assessments in connection with the AESA planning activities by DARPA and the Services was specifically directed toward manufacturable broadband microwave arrays. We concluded that the following developments were needed:

- Miniature control components (filters, couplers, circulators)
- Manufacturing science programs since price tag is a "show stopper"
- Chip compaction/higher levels of integration
- Flexible manufacturing lines since absolute "common" module specifications appear to be impossible to achieve
- Improved power added efficiency (especially over wide bandwidths)
- The application of plastic encapsulated components and sound approaches to reliability without hermeticity (RwoH)

DCS was directed to perform the following tasks under the Defense Advanced Lithography Program:

- Technology monitoring
- Progress assessments
- Development of draft program documentation
- Technical consultation

DCS was tasked to perform quality assurance testing and reliability assessments on the various microwave integrated circuits delivered to NRL from MIMIC, MAFET, and DALP contractors.

#### 4.1 DALP Program

Electronic circuits have been decreasing in size by 50% every three years since the mid 1950's. Currently commercial microcircuits are routinely manufactured using 0.50  $\mu\text{m}$  design rules. Advanced microelectronics is key to fielding superior radar and infrared sensors, electronic warfare electronics, communications, avionics, missile guidance, navigation, and other advanced weapon systems. Microcircuit miniaturization improves the capability of electronic systems and reduces volume and weight. This realization has led the Navy to invest in the development of advanced microcircuitry manufacturing capability, including x-ray lithography, optical phase shift technology, deep UV lithography, and other advanced technologies.

Further miniaturization requires improvements to the microcircuit lithographic process, which is the technology involved with imprinting circuit patterns on semiconductor wafers. The size of microcircuits is limited by the physical size of the mask used to pattern the circuit, the wavelength of electromagnetic radiation used to expose the photoresist, and the positioning capabilities of the aligner used to align the mask and wafer. Optical lithographic technology is currently reaching its practical limits using excimer lasers operating at 248 or 193 nanometers (deep ultraviolet) which can achieve a feature size of 0.25 microns.

The Navy, under sponsorship of the Advanced Research Projects Agency (ARPA), began the Defense Advanced Lithograph Program (DALP) in 1988 to develop x-ray sources, mask technology, electron beam (e-beam) writers, aligners, and pilot line demonstrations of the technology needed to extend microchip manufacturing capability into the 0.13  $\mu\text{m}$  design rule technology and below by 1998. The DALP program has succeeded in demonstrating the pilot line manufacture of 0.25  $\mu\text{m}$  chips using x-ray lithography and is now seeking to extend the technology to 0.18  $\mu\text{m}$ , 0.12 $\mu\text{m}$ , and below. X-ray lithography, using 0.04 to 0.50 nanometer wavelength synchrotron x-rays, has the long term potential of imprinting circuit patterns on wafers to dimensions below the 0.03 micron limit, where quantum mechanics uncertainties prevent transistors from functioning as valves. The \$600 million DALP program required the Navy to manage and coordinate the activities of seven companies (Loral, IBM, AT&T, ETEC, Lockheed-Sanders, KLA Instruments, and Micrion) and several universities (University of Wisconsin, MIT, and Louisiana University) to develop the sophisticated x-ray lithography technology.

Many of these programs evolved out of research programs developed in Navy laboratories which were transferred to industry, and are now being scaled up to pilot production status. Generally the third phase of these programs requires the application of the technology to specific weapon systems. Navy Program Managers must ensure that: the program goals are met, new and modified contracts are issued on time, industrial activities interface and complement Navy requirements, trade-off studies are conducted to ensure the application of optimum technologies, budgets are met, an industrial infrastructure is established to continue the technology beyond

Government support, the technology is disseminated between participants, and that the Navy benefits from the technology.

DCS has been supporting the DALP program since 1990 when management of DALP was transitioned from NRL to NAVAIR. During the program transition period, DCS assisted in transcribing verbal agreements into draft program documents under a previous DCS contract. Management and technical support of DALP was continued in October 1992 under a new DCS contract. DCS continued to assist in drafting and updating programmatic documents. DCS also became increasingly involved with the issuing and monitoring of vendor contracts as the DALP program grew to \$100 million in annual funding. In addition to specific tasking, DCS continually provided DALP Navy program managers with technical and programmatic expertise that kept the program on-track during chaotic periods when conflicting demands of Congress, ARPA, major and minor vendors, and Navy requirements often had to be reconciled while maintaining focus on the technical goals of the project.

DCS assisted in management tasking of all DALP contracts including programmatic support, scheduling and arrangement of reviews, and other actions as required. Approximately 50 DALP contracts were tracked during the period of DCS support including contracts with IBM, Etec, Sanders, AT&T, Loral, Lockheed-Martin, MIT, SVGL, and the University of Wisconsin.

DCS tracked contract deliverables. DCS established and maintained a filing system at NAVAIR to organize the Contract Data Requirements List (CDRL) documents received by the DALP program manager. Deliverables were reviewed and reported on to NRL/NAVAIR management throughout the contract period.

DCS personnel served as "honest brokers" between the DALP vendors and the Government. This function was particularly valuable in resolving differences between Government documentation requirements and industry final product orientation. In this capacity, DCS personnel attended contractor reviews, Technical Interface Meetings (TIMs), and contractor kick-off meetings along with Government representatives.

DCS provided the DALP program office with program tracking documentation which included:

- Capsule Summaries for the Defense Advanced Lithography Program
- Historical Milestones and Actions
- X-Ray Lithography 0.35  $\mu\text{m}$  Device Fabrication Technology Roadmap
- Design Rule History White Paper
- DALP Contract Funding History
- The Technology of Positioners

#### 4.2 Microwave Quality Assurance Testing and Reliability Assessment

Major R&D programs, such as VHSIC, MIMIC, DALP, and MAFET, require the contractor to periodically deliver Standard Evaluation Circuits (SECs) and other sample microcircuits to the Government to demonstrate progress towards achieving R&D and

manufacturability goals. The Electronics Science and Technology Division at the Naval Research Laboratory (NRL) has primary responsibility within the Navy to evaluate these SECs.

As microcircuit technology advances, the standard devices (e.g., bipolar transistors, MESFETs, PHEMTs, and HBTs) are redesigned and fabricated using smaller design rules and/or using different substrate materials (e.g., Si, GaAs, InP, GaN, and SiGe). These advances involve changes in fabrication processes, chemistry, and materials composition. Consequently, each new generation device will perform differently and fail differently than previous versions of similar devices. Each new device therefore becomes the subject of intense studies by Government and industry to "relearn" its performance characteristics and failure mechanisms.

The Reliability Science Section at NRL is involved with the identification and explanation of observed next generation microcircuit failure mechanisms. Microcircuit devices are tested to destruction and the results are statistically analyzed. Individual failed devices are analyzed to identify the failure mechanism using a variety of laboratory tools. Visual observations of failures must be supplemented with infrared microscopy, electron microscopy, and x-ray analysis, since the observed damage is not always the cause of the failure. Causative failures, such as dopant migration, impurities, incorrect stoichiometry in alloys, adhesion failures, and film deposition failures are often difficult or impossible to positively identify. The classification of observed failures and subsequent statistical analysis are therefore considered sufficient for purposes of failure characterization in most NRL device studies. Studies of specific failure mechanisms are undertaken as independent research efforts.

SECs and other sample microcircuits are typically received at NRL in lots of 40, mounted on carriers, and attached to mounting plates or packaged in plastic boxes. These SECs are received, inspected, and life tested by NRL to verify that contract goals have been met and to assess quality and reliability. The inspection of a single lot of SECs is a process that may span a considerable period of time depending on scheduling, AIRTASK requirements, and/or research goals. Visual microscopic inspections are usually performed on the entire lot of SECs, followed by life testing. The typical SEC inspection and life test procedure implemented by NRL is outlined in Figure 4-1.

During the period of this contract, the DCS role in quality assurance testing and reliability assessment expanded from that of providing directed laboratory assistance to that of providing independent sub-task support using a variety of laboratory instruments and tools. Documentation efforts evolved from that of providing raw photographic data organized into notebooks, to that of providing raw and processed data along with an appropriate analysis. The data and analysis were combined, along with all relevant supporting data including: specifications, dates, serial numbers, codes, item numbers, and other parameters, into a complete and independent laboratory report describing all work performed on the sub-task along with relevant observations. In this form the reports provided adjunct support for research papers being written by NRL scientists.

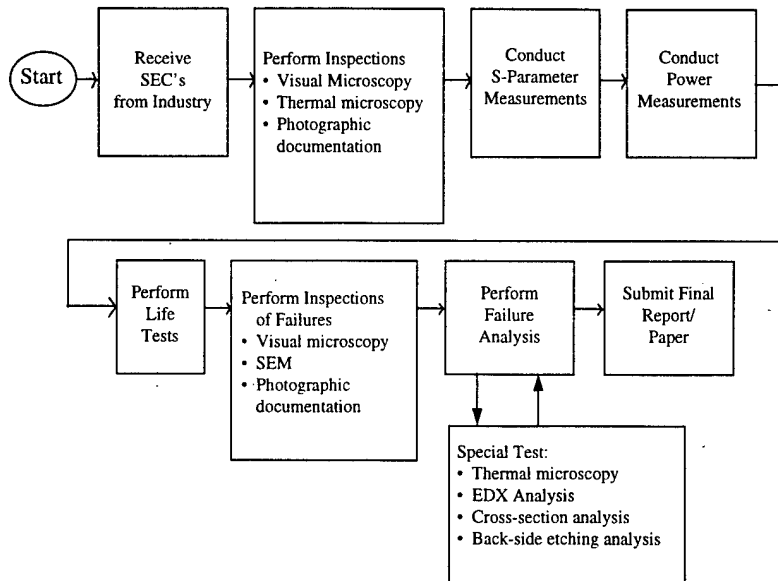
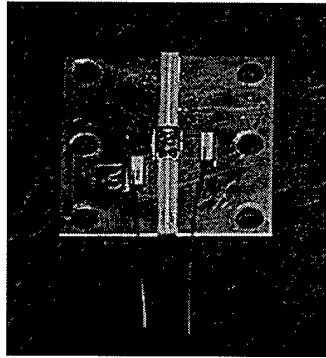

**Figure 4-1. SEC Life Test Procedures.**

DCS expanded its role during the latter part of this contract to include providing reports on specialized topics of interest to the Reliability Science Section. These reports included three research reports, two instruction manuals, and a photographic inventory of all microchips received at NRL as a result of the MIMIC program. DCS also carried out two fabrication tasks for lifetest fixtures.

#### 4.2.1 Visual and Microscopy Microchip Inspections

The majority of MIMIC microchips received by the NRL Reliability Science Section during the period of performance of this contract were visually and microscopically inspected by DCS personnel. Inspections consisted of removing microchips, usually mounted on carriers, from their protective mounting plates or plastic cases, and observing them under a binocular zoom inspection microscope that was usually set to 14X magnification. Defects in bonding wires, solder workmanship, and other observed problems were noted and recorded. A second inspection was then performed using a camera equipped Metallux microscope set at 50X, 100X, or 200X magnification. Defects such as foreign particles on the chip surface, scratches, discoloration, and collapsed air bridges were noted and recorded. Photographs were then taken at low magnification of the entire chip before and after life testing. Severe defects were photographed at higher magnifications.



**Photo 4-1. TI type EG8610 device mounted on carrier.**

A photograph of a typical microchip mounted on a 1 X 0.875 inch carrier plate is shown in Photo 4-1. Additional photographs of microchips are provided in Appendix A, numbered from 1 to 15. An example of microchips in wafer form is shown in Photo 1. Examples of typical MIMIC microchips mounted on carriers are provided in Photos 2, 3, and 4. Photographs of TI EG8610 microcircuits with defects are shown in Photographs 5 through 8. Photo 5 shows an exceptionally dirty microchip probably caused by incomplete removal of the photoresist during the stage of fabrication. Photo 6 shows a very unusual cracking of a microchip substrate, probably caused by thermal expansion effects during life-testing of the chip. Photo 7 shows what is very likely a short circuit along the top of a capacitor. Photo 8 shows a baked-on chemical liquid spill covering most of a capacitor and surrounding area. All the MIMIC microchips photographs are of analog microcircuits designed to operate in the 2 to 20 GHz frequency range. FET gate lengths are 0.25 to 0.50 microns. The brightly colored backgrounds of these chips is caused by optical light interference effects within the thin transparent coatings used to protect the chips from moisture and the environment.

In the early phase of the DCS contract we documented visual microchip inspections manually in notebooks, but later a computer assisted program was developed which allowed recording visual inspection data directly into spreadsheet format. Laboratory procedures were expanded to include the recording of procedures developed to collect data from a variety of laboratory instruments. DCS instituted the practice of collecting the photographs, visual observations, and recorded procedures into a formal report which was issued at the completion of each inspection assignment. DCS submitted the following MIMIC inspection reports during the course of this contract:

- MIMIC Microchip Photographic Inventory; MIMIC Microchips Received at NRL from 1988 to 1996
- Inspection of TI Two-Stage PHEMT Power Amplifier SECs
- Inspection of Standard Evaluation Circuits (SEC); 0.25 Micron Low Noise Amplifiers
- Re-Inspection of Raytheon Two-Stage MESFET Power Amplifiers SECs After Destructive Testing

#### 4.2.2 Scanning Electron Microscope (SEM) Microchip Inspections

DCS personnel used the Model ISI-5540 Scanning Electron Microscope (SEM) to examine microchip failures. A portion of the microchips underwent life-testing at elevated temperatures and experienced a variety of catastrophic failures. Under NRL direction, DCS personnel examined a number of these failures using both optical microscopes under the high magnification and the scanning electron microscope. The SEM scans of failure sites were photographed and documented.

Four different types of microcircuit catastrophic failures are shown in Photographs 9 through 12 in Appendix A. Photograph 9 shows material that has probably evaporated from under a transmission line and then solidified as crystals on the top of the cooler substrate. Photograph 10 shows a possible eruption of materials from a lower level of the chip, probably due to a short circuit. Photograph 11 shows damage caused by scratching, possibly with dirt deposits. Photograph 12 indicates ejecta near the site of another short circuit. The DCS SEM photographs and data were presented to NRL in the report titled "Re-inspection of Raytheon Two-Stage MESFET Power Amplifier SECs After Destructive Testing".

#### 4.2.3 Infrared Scanning Microscope Microchip Inspections

DCS employees performed infrared (IR) scans on carrier-mounted microchips for the Reliability Science Section. A CompuTherm III Infrared Scanning Microscope (ISM) was used to produce the scans on each microchip before and after life testing to identify locations of components failures and degradation caused by the testing. The resulting IR scans were taken at several levels of magnification to examine the entire chip, or single components on the chip. The IR scans were viewed on a color computer screen, saved on computer floppy disks, and printed on a color printer.

The ISM is a complex instrument consisting of a liquid nitrogen cooled IR scanning head which views the microchip through one of two interchangeable gallium arsenide lenses. The chip is mounted on a stage with precision three axis adjustments and a thermal electric heating and cooling system. The IR image data passes into a computer with custom software for controlling the scan head, temperature of the stage and other I/O devices.

The thermal imaging process is quite complex since radiance scans must be taken above and below the final temperature scan. Emissivity must be calculated, a Device Under Test (DUT) scan must be taken to eliminate reflective infrared radiation data, and an unpowered measurement must be made before the final temperature scan is made. All these scans must be in exact alignment with one another despite thermal expansion effects. Mechanical adjustments must be made by the operator to eliminate these effects. DCS employees mastered the operation of the ISM during the course of the contract period and have written operating instructions for the instrument.

An example of a thermal scan of a microchip, with bias power applied to it, is provided in Photograph 13 in Appendix A. The lower ISM image shows the two radiance scans, the emissivity calculated image, and the unpowered temperature scan that were required prior to the

final DUT powered thermal image scan. Photographs 14 and 15 in Appendix A are a similar microchip at two different magnifications; Photograph 14 shows a magnified view of the second stage amplifier (where most failures occur) and Photograph 15 shows the entire chip. The thermal image data taken by DCS was documented in lab notebooks, on computer disks, in notebooks of scan images, and in the following formal reports submitted to NRL:

- IR Imaging of Raytheon TS-0020 Power Amplifiers Before and After Life Testing
- Infrared Scanning Microscope (ISM) Operating Instructions
- IR Imaging of Raytheon PHEMT Two-Stage Amplifiers Before and After Life Testing

#### 4.2.4 Power and S-Parameter Measurements

During the period of this contract DCS assisted the NRL Reliability Science Section in conducting S-parameter measurements and power performance measurements on PHEMT power amplifiers. Measurements were made of the  $S_{21}$  transmitted microwave signal gain and of  $S_{11}$  reflected signal loss through various MIMIC DUTs. Plots of the  $S_{11}$  and  $S_{21}$  performance characteristics are made of all devices before and after undergoing life-testing over the frequency range 2 to 20 GHz to verify device gain and to determine performance degradation as a result of testing. The test setup used in these measurements is shown in Figure 4-2:

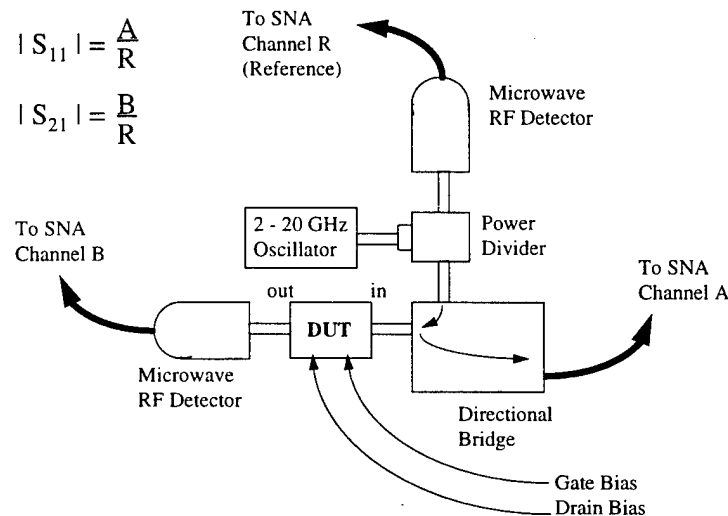

**Figure 4-2. Experimental set-up for S-parameter measurements showing microwave signal path, DUT, and positioning of RF detectors.**

DCS also assisted the NRL Reliability Science Section in conducting power measurements on selected MIMIC amplifiers before and after life-testing. In this series of measurements power-in is measured against power-out over a frequency range of from 6 to 18 GHz to determine the range of device linearity. Measurements made before and after life-testing are compared to determine performance degradation as a result of testing. These measurements were made using the test set-up shown in Figure 4-3:

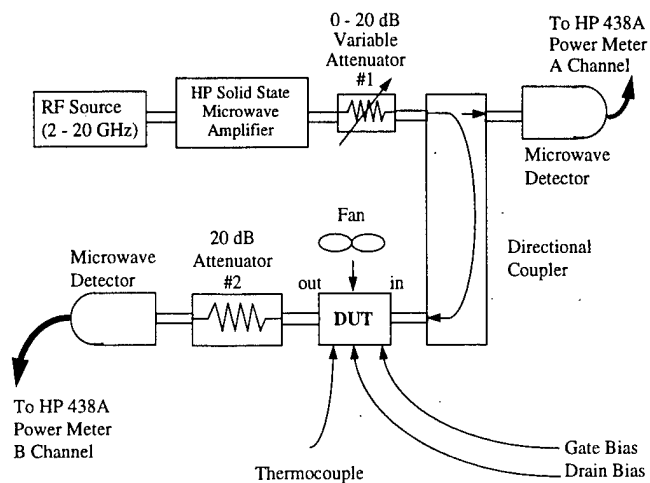

**Figure 4-3. Experimental set-up for power measurements showing microwave signal path, DUT, and positioning of RF power detectors. In this test the DUT has high power applied to it and therefore its temperature must be monitored by a thermal couple and cooled with a fan.**

DCS processed and plotted the raw S-parameter and power measurement data using KaleidaGraph™ software and submitted the resulting plots to NRL in the following reports:

- S-Parameter Measurements of Radiation Exposed Two-Stage PHEMT Power Amplifier SECs
- Power and S-Parameter Measurements on Raytheon PHEMT Power Amplifiers

#### 4.2.5 Miscellaneous Analysis and Reports

DCS performed a number of special analyses and research projects on behalf of the NRL Reliability Science Section during the course of this contract. This work consisted of conducting background library research on various technical subjects, conducting scientific evaluations, and documenting laboratory procedures. Special projects documented in reports submitted to NRL during this period include:

- Potential of High Purity Silicon for use as IR and Optical Sensor Material
- Analysis of Experimental Data, Neutron Radiation Induced Current Transients
- Wire Bonding Procedures and Techniques, Manual Operation of Logicon, Model 5C, Wire Bonding Machine
- Infrared Scanning Microscope (ISM) Operating Instructions

All reports submitted under this task were authored by Maurice Daniel and were delivered throughout the period of this contract. See Appendix B.

## 5.0 TASK 5: TECHNOLOGY INSERTION

The electronics technology revolution has provided dramatic improvements in electronics integration and component density. Microwave and microelectronics technologies will transition to numerous aviation applications. For instance, the term avionics encompasses many related technologies, including sensors for target detection and tracking, antennas to send and receive data, algorithms, backplanes, databases and processors to analyze the data, communication and navigation functions, links for Joint Force operations and information warfare, and displays to interact with the flight crew in a timely and usable manner. The avionics system must not only be mission capable, it must also consume minimum power, be lightweight, reliable, maintainable, and affordable.

DCS investigated a number of Navy and DARPA sponsored systems for applicability of emerging technologies identified in Tasks 1 through 4. The Maritime Avionics Subsystems and Technology (MAST) program is perhaps one of the broadest in terms of technology investigations. The overall objective of the MAST program is to provide for the low-risk insertion of affordable advanced integrated modular avionics in current and next generation Navy platforms. Other related applications which we have investigated include anti-submarine warfare, ECCM communications & electronic protection communications, F-18 avionic systems, Rapid Prototyping of Application Specific Signal Processors (RASSP), smart munitions, low observable technology, H-53 systems engineering, as well as many other technology transition possibilities.

DCS analyses have included cost/performance trade-off investigations of the potential for significant improvements to existing and future systems. DCS has provided recommended technology insertions and possible transition paths, and identified potential technology transfer opportunities. A summary of our analyses and investigations on technology transitions is contained in the paragraphs which follow.

### 5.1 Maritime Avionics Subsystems and Technology (MAST)

The MAST program is a 6.3A core development effort that ties together the many diverse but related avionics technologies. The MAST efforts comprise critical components of evolving integrated avionics and scaleable advanced avionics architectures. The MAST program has evolved over the past thirteen (13) years. Formerly called the Advanced Avionics Subsystems and Technology (AAS&T) Project, it is the core program for avionics technology suitable for evolving major Navy programs (A/F-X, F/A-18 E&F, JAST/JSF). The MAST program consists of five major technology areas, and each technology area contains one or more active and/or planned projects. The technology areas comprising the MAST program are:

- Scalable Open Architectures
- Situational Awareness, Re-targeting and Crew Workload Reduction
- Avionics Interconnects
- Avionics Packaging & Power Systems
- Low Cost Sensor Systems and Connectivity

Key technologies related to and within MAST include: fiber optics, integrated architectural concepts, photonics, MIMIC, MAFET, advanced composite materials, two-phase immersion cooling, VHSIC Hardware Descriptive Language (VHDL), Microwave Hardware Descriptive Language (MHDL), Vacuum Electronics, RASSP, Multi-Chip Modules (MCM's), behavioral simulation and modeling, signal and image processing, data fusion, radar, ESM, ECM, antennas, embedded fibers and antennas, PCMCIA's, control electronics, Low Probability of Intercept, software engineering, and high performance computing.

DCS coordinated the efforts of Government laboratory and industry personnel concerning numerous issues which included technology insertion, cost/performance trade-off studies, execution plans, schedules, funding, and briefings.

DCS participated in numerous MAST technical conferences and meetings relating to program activities and transition opportunities such as:

- The "kick-off" meetings for the TI and Westinghouse contract efforts of the ASAP DEM/VAL Phase A program;
- The ASAP review meetings at Texas Instruments and Westinghouse to monitor GaAs MMIC and T/R module progress;
- Meeting hosted by NAWCADWAR on Naval Avionics Technology;
- NRL Radar Review which covered the Radar Division's exploratory development efforts, phased array technology, shipboard and airborne radar, analyses/modeling, new systems, upgrades, and signal processing developments;
- Numerous Government and industry meetings involving the principal contractors associated with the MAST program, including a meeting with JAST personnel, and a MAST Demonstration Planning meeting at Cambridge Research Associates (CRA);
- Demonstrations at Cambridge Research Associates (CRA) using PowerScene for enhanced situational awareness.

DCS coordinated a MAST program Review at the Naval Postgraduate School (NPS) in Monterey, CA; DCS developed the agenda, planned, coordinated, and organized all activities with the NPS and the Monterey Hyatt Hotel; attendees consisted of 105 military/Government and industry personnel.

DCS took a pro-active role in drafting, compiling and editing many versions of the MAST program Execution Plan (PEP), both individual year plans (FY94 - FY96) and multi-year plans for submission to ONR and other agencies. We regularly coordinated with personnel at various Government field activities (NAWCADWAR, NAWCADIND, NRL), NAVAIRSYSCOM engineers and program managers (e.g., Avionics IPT, PMA-263, PMA-209), the JSF JPO and several Industry partners. This interface was required to obtain and consolidate inputs, review technology insertion opportunities, and develop transition strategy for inclusion in the PEP, including both "technology push" and "requirements pull" aspects, and respond to new PEP formats from ONR.

DCS assisted with other programmatic documentation; for example, we drafted a "Non-Acquisition 6.3 program Information" document and edited avionics R&D data for inputs to the Naval Aviation Systems Team Annual Report.

DCS was regularly involved in funding and budgeting actions, both with the field activities and Laboratories and with higher headquarters such as OPNAV and NAVCOMPT; for example we:

- Were responsible for developing AIRTASKs and amendments in the areas of Shared Aperture Antenna Systems, Digital Technologies, Avionics Photonics, Avionics Packaging, and Situation Assessment & Awareness. Specific tasks addressed were:

NRL

Wideband Shared Aperture Components & Systems Support

Advanced Architecture Studies & Support

Software & Situational Assessment Support

NAWCADWAR

Airborne Shared Aperture Program (ASAP)

Special Airborne Antenna System (SAAS)

Fault Tolerance

Multi-Sensor VHSIC Signal Processor

Sensor Data Distribution Network

NAWCADIND

Advanced Avionics Algorithms

Advanced Data Bus Development

Advanced Avionics Packaging

NPS (Naval Postgraduate School)

Topics in Advanced Avionics Technology

- Assisted in the preparation of program summary briefing information (objectives, payoffs, requirement thresholds, issues, and major milestones) for submission to OCNR/OAT and subsequent use by ODDR&E in meetings of the Defense Science and Technology Working Group; updated budget and expenditures plans; drafted revisions to the R&D Descriptive Summary Documents; compiled and edited responses to a Senate Appropriations Committee (Defense Staff) R&D inquiry; drafted mid-year funding deficiency impact statements for the five program areas; coordinated and prepared point papers, reclaims, and impact statements in response to the congressional zeroing of FY-94 funding and prepared impact summary documents; drafted a paper comparing the original FY 94 R&D Descriptive Summary (RDDS) with the current recommended MAST Core Avionics program tasks; prepared response to ONR concerning release of FY96 OSD-deferred funds for Congressional plus-up programs; prepared R-2 input (MAST accomplishments and plans) for the FY97 Congressional budget submission.

Additional MAST-related studies, investigations and assistance by DCS included:

- Reviewed and updated a data base of programmatic and technical references;
- Compiled and assessed information and materials for a program overview presented to the ONR staff;
- Reviewed data related to proposed new developments and reapportionment of resources for two efforts, OBIS (Optical Backplane Interface System) and LCSAE (Liquid Cooled Standard Avionics Enclosure);
- Reviewed Advanced Technology Demonstration Plans from Raytheon/TI for the ASAP and Q-Band VCO demos;
- Compiled and edited program data and management information for a presentation to ODDR&E (Tri-Service S&T/Reliance Review);
- Compiled information and materials for the ONR review of the Aircraft & Avionics program;
- Assisted in preparing a briefing presented to PEO(T) and PEO(A) on technical and funding issues;
- Compiled data on proposed avionics technology development and insertion "visions" for subsequent presentation to ODDR&E officials;
- Prepared briefing materials on the re-scoped ASAP effort for presentation to the JSF JPO;
- Reviewed and commented upon draft S&T Guidance for pervasive, high priority requirement and advanced technology demonstrations;
- Prepared data and presentation materials for an Advanced Airborne Situational Assessment & Awareness System (AASAS) briefing to the JSF Office;
- Regularly assisted in preparing MAST briefings for ONR and other organizations;
- Coordinated and assembled a Phase 2 SBIR contract package with CPU Technology for an advanced emulator chip.

## 5.2 Anti-Submarine Warfare

DCS supported PMA-264 and AIR-4.5T in the transition of new technologies for incorporation in the Advanced ASW Receiver (ASR) Advanced Technology Demonstration (ATD) program. DCS investigations and assistance included:

- Provided technical comments and recommendations on contractors monthly technical reports;
- Reviewed and coordinated completion of the ASR ATD Execution Plan;
- Prepared ASR ATD presentation for the PMA-264 review;
- Participated in a technical review of the prime contractor's progress on the ASR contract;
- Arranged for the loan of an acoustic test signal generator for a one year period during the test phase of the ASR ATD;
- Assisted Project Manager in the preparation of a briefing for the National Security Industrial Association;

- Scheduled and arranged for a technical briefing on the ASR ATD by the prime contractor for selected Navy personnel;
- Initiated ASR ATD test planning with Government personnel.

### 5.3 ECCM Communications & Electronic Protection (EP) Communications

DCS provided engineering, technical, and program management support to the NASC PMA-209 for a preplanned product improvement (P<sup>3</sup>I) effort to the Navy standard airborne UHF/VHF AM/FM and ECCM radio. Task was for the R&D phase of an ECP that would permit the AN/ARC-210(V) family of equipments to operate with: (1) the Downed Aircrew Locator Systems (DALs); (2) interoperability with GAPFILLER, FLTSAT, LEASAT, and UHF Follow-On DoD Satellites; and (3) Link 4A and Link 11 capable terminals. P<sup>3</sup>I efforts also included LPI waveform development and investigation of an embedded ATHS modem.

DCS provided technical, engineering, and programmatic support in the following areas:

- Analyzed the submitted technical proposal in relation to Navy communications equipment specifications for validity of assertions;
- Investigated specific technology insertion opportunities during scheduled design reviews (SRR, SDR, PDR and CDR). Our assessments were oriented toward: 1) Low Noise amplifiers for SATCOM; 2) GaAs based attenuators for receive blanking; and 3) a MIMIC-based IF stage to implement a receiver up-conversion scheme.
- Developed five options which range from design and integration of a Downed Aircrew Locator System (DALs) upgrade to the AN/ARC-210(V) system to a DALs, SATCOM (DAMA & ANDVT) and Data Link (Link 4A/11) compliant system;
- Conducted the electro-optics testing of the AN/ARC-210(V) Night Vision Compatible Remote Control Unit; testing identified out-of-specification conditions for the display illumination intensity and lack of edge lighting for the control panel; compatibility with NVIS "Cats Eyes" was also evaluated;
- Investigated alternative approaches for procurement of ancillary devices (e.g., 100w High Power Amp, Low Noise Amplifier for SATCOM receive mode, conformal SATCOM antenna) to fulfill system requirements;
- Evaluated various technical issues and recommend engineering solutions toward implementing SATCOM, Downed Aircrew Locator System (DALs) and Tactical Data Link capability in the baseline AN/ARC-210(V) radio;
- Reviewed technical accomplishments, performance predictions and qualification plans for DALs, Data Links and SATCOM;
- Participated in the System Requirements Review (SRR) of the Low Probability of Intercept (LPI) Advanced Technology Demonstration (ATD) program; the AN/ARC-210(V) was selected by the Navy as the radio to utilize this new waveform during the ATD phase; provided technical papers and explanations of the SINCGARS "Lock-up" problem as well as the FM thresholding effects;

- Concluded study on Class I Ozone Depleting Substances (ODSs) currently required by AN/ARC-210(V) contracts and provided a report indicating the prohibited chemical substances (e.g., trichloro-trifluoroethane) employed during radio manufacture and the location of the requirement for their use in Level 1 and Level 2 Military Specification and Standards; developed recommended contractual language changes to place the radio program within compliance of federal (EPA) and Navy laws and guidance;
- Participated in a review and demonstration of improvements to DALs ranging and bearing measurements against the PRC-112;
- Attended LPI ATD "forced synch" demonstration at the contractors facility; potential "susceptibilities" of the system were documented;
- Developed a AN/ARC-210(V) Installation Architecture Book to document all host weapon system integration approaches by block wiring diagrams;
- Provided detailed presentation on Link 4A/Link 11 (TADILs C and A) implementation, specifically addressing the airborne equipment interfaces;
- Initiated update of the AN/ARC-210(V) equipment specification to better characterize resolution of technical issues, First Article Testing (FAT) performance, and changes necessitated by lead platform installation;
- Participated in a review of the Integrated Battlefield Information Terminal (IBIT), which is the Navy's program to integrate the airborne CNI functions into an open reconfigurable architecture with SEM-E type modules and a common backplane.

#### 5.4 F-18 Avionics

The F/A-18 was suffering from parts obsolescence with its current digital map system as well as changes to the DMA product line that would result in map data incompatibility with the current system. F/A-18 targeting FLIR performance was judged to be inadequate to accommodate new weapons capabilities. A Congressionally mandated requirement for all aircraft to have GPS by the year 2000 required a program that could accommodate all models of the F/A-18 as well as new weapon systems. DCS played a key technical role in implementing these updates in the F/A-18 for the NASC F-18 PMA. The following paragraphs enumerate DCS's participation in these efforts.

##### 5.4.1 GPS Integration

Efforts to integrate GPS receivers resulted in two systems being used on the F/A-18 - the Miniaturized Airborne GPS Receiver (MAGR) and the Embedded GPS/INS (EGI). The MAGR integration was designed to work in conjunction with the ASN-139 ring laser gyro INS already on the aircraft. The EGI incorporates an INS and a GPS receiver in the same WRA and replaces the ASN-139. DCS performed a study which showed that integration of GPS on the early F/A-18 A and B models would require the 1553 mibus system be upgraded to 5 buses in order to handle the additional bus loading, this requirement was incorporated into the integration design. DCS prepared and delivered a briefing to FMS program managers explaining the different levels of GPS service available to foreign customers and recommended possible implementation configurations.

#### 5.4.2 Digital Map

The Tactical Aircraft Moving Map Capability (TAMMAC) replaces the current ASQ-196 Digital Video Map Set (DVMS). The DVMS uses a spinning Aircraft Optical Disk (AOD) to store digitized raster graphic representations of paper charts. The TAMMAC system utilizes either a solid state memory or a militarized hard disk with almost a 10 times greater capacity than DVMS. Other features of TAMMAC are dynamic threat displays, DTED database capability, organizational loading capability and an improved data loader. This Advanced Memory Unit (AMU) loader provides greater than 10 times the capacity of the present loader to support mission and maintenance data requirements. DCS suggested configuration management for the F/A-18 AOD inventory and demonstrated how the F/A-18 could provide AOD support for the AV-8B program until the TAMMAC system was deployed. DCS provided a study which resulted in TAMMAC incorporating more memory than was originally planned in order to support F/A-18 mission requirements. F/A-18 performance requirements were developed by DCS for TAMMAC and included suggested growth requirements to support targeting and navigational capabilities. We provided the basic requirements for loading and updating map databases in support of the TAMMAC/TAMPS integration. DCS worked with NRL Stennis to develop a demonstration study that allowed F/A-18 pilots to operate simulated TAMMAC interfaces and provide input on TAMMAC capabilities and integration design.

#### 5.4.3 FLIR

DCS participated in design process for F/A-18 E and F model targeting and navigation FLIRs. We conducted market surveys and evaluations for the Advanced FLIR capability and performed computer modeling of proposed FLIR designs' performance. We evaluated request for information for FMS programs on FLIR technology and evaluated releases for technical accuracy. DCS participated in resolution of FLIR laser performance at high altitudes and suggested design changes to meet F/A-18 performance requirements. We developed target sets in conjunction with "Strike U" for incorporation into F/A-18 ORD requirements. We participated in FLIR Day '96, a symposium exploring FLIR design alternatives for the F/A-18 mission.

#### 5.5 Rapid Prototyping of Application Specific Signal Processors (RASSP)

DCS supported NRL Code 6800 on the RASSP program as follows:

- Provided technical assistance to NRL in the proposal evaluation of the RASSP; DCS duties included developing the evaluation checklist, notifying evaluators of time, place, and schedule for proposal evaluation, sending invitations and information to all evaluators, assembling evaluator packages, registering evaluators, providing for proposal security, compiling list of proposed demonstrations, and providing technical assistance to team leaders and evaluators;
- Attended RASSP kick-off Program Review and studied all technology base tasks covering ten universities;

- Studied Program Review data including the development demonstrations, benchmarking, and technology development with the universities; prepared a summary report to ONR;
- Studied the MIT RASSP Benchmark-1 (Synthetic Aperture Image Processor) documentation which contained background information for use by Lockheed Sanders and Martin Marietta; provided comments to NRL;
- Attended the ARPA/Tri-Service Program Review of Lockheed/Sanders; prepared summary report and arranged for NRL briefing to SPAWAR;
- Prepared reports and facilitated discussions between NRL and NAVSEC, Norfolk on briefing and visits;
- Reviewed RASSP report on Lockheed/Sanders of case study on Advanced Intra-Pulse Processor System and Acoustical Signal Processor System;
- Arranged briefing for NRL and NWSC (Crane) by NAVELEX-System Center, Portsmouth, VA;
- Attended C3I review by NAVELEX System Center and RASSP review by NRL;
- Prepared data for acquisition seminar and for RASSP and C3I reviews;
- Reviewed all RASSP contract status reports and technical notes;
- Reviewed information contained in two briefings and prepared reports:
  - OSD Public Affairs: "Defense Technology Strategy and Plan".
  - Defense Information System Agency: "Jointness C4I".
- Attended DoD Advanced Communication Review at DCS and prepared summary report.

## 5.6 Smart Weapons

The DCS office at Eglin AFB, FLA supported the transition of "smart" weapons as follows:

- Reviewed JDAM LRIP decision criteria;
- Completed the final draft for the Program Planning Document (PPD);
- Prepared comments on the JDAM Test and Evaluation Master Plan (TEMP);
- Participated in discussions with Motorola concerning design changes and test methods;
- Provided input on the JPF instrumented sled and instrumented cannon tests;
- Provided input to several JDAM and JPF test readiness meetings;
- Provided several JDAM Quick Look Reports to the Test IPT community on current and scheduled test events and their results;
- Provided updates for several JDAM briefings and prepared weekly JPF and JDAM test updates to PMA-201 and Navy team.
- Made major changes to the PPD that were requested by Headquarters, Marine Corps, based on policy changes which had been recommended.
- Reviewed and provided comments on the JDAM HERO Test Plan.
- DCS participated in the test of six JPF units that were built to verify the Retractable Piston Actuator (RPA) fix. These tests indicated that the battery had

moved, causing a sustained short on the delay module. Once stereo lithography models are completed of the new part, sub assemblies will be built and tested. All up fuzes will then be assembled and tested to verify the fix.

- DCS participated in a JDAM ground mount at China Lake with the JPF. As a result of problems observed on this test and another on the F-16, there was a JDAM/JPF interface test conducted to determine the source of the interface abnormalities detected during F-16 captive carry and F-18 ground mount testing. DCS will participate in further testing to resolve this interface problem.

## 5.7 Advanced Technology Investigations

### 5.7.1 APOLLO

This program is an Advanced Technology Demonstration initiative to develop advanced technologies for low cost (<\$50K) guided munitions. This joint Navy/Air Force program encompassed both weapon and aircraft components for advanced weapons guidance systems, and is specifically oriented to P3I technology insertion upgrades for JSOW and JDAM. These technologies include composite airframes, podless anti-jam digital data links, low cost IR imaging seeker technologies, and advanced mission planning concepts for real time targeting. DCS supported this initiative by drafting a NAPD, reviewing technical inputs from NAWC-CL, and supporting coordination between NAVAIR and other technical activities. DCS supported technical and programmatic briefings relating to program status and insertion planning. APOLLO was eventually terminated due to lack of funding, and DCS compiled a summary of technical progress achieved as a baseline for future development programs.

### 5.7.2 IRFPA/FM

Infrared Focal Plane Array/Flexible Manufacturing is an ARPA initiative to develop manufacturing techniques for fabrication of multiple focal plane array devices in a common flexible production facility. The Navy was responsible for managing one of the major IRFPA / FM contracts with Lockheed Martin IR Systems, Lexington, MA. This program is required to develop and demonstrate manufacturing techniques for multiple types of focal plane arrays including staring, scanning, cooled HgCdTe, and uncooled devices. DCS collaborated with NAVAIR to develop technical and programmatic briefings to ARPA sponsors, potential NAVAIR insertion candidates, and for the ARPA IRFPA/FM Industry Review. A significant DCS activity involved modeling and performance analysis of IRFPA/FM products for insertion into candidate systems. These included scanning (SADA) , staring, and uncooled arrays. There is specific interest in evaluating the use of uncooled detectors in imaging seekers as a means to significantly reduce cost, cryogenics complexity, and weight/volume. DCS performed preliminary trade analyses to evaluate the sensor performance as a low cost P3I insertion candidate for the JSOW imaging seeker. DCS also supported preparation of a technical paper, "System Engineering of Computer Integrated Manufacturing" which documents a system engineering approach to formulate the architecture and design of an infrared focal plane array CIM factory. Finally, DCS prepared a paper describing the family of Standard Advanced Detective Assemblies (SADA) being developed by the Army, and their intended DOD system insertion opportunities.

### 5.7.3 DAMASK

DAMASK is a planned FY98 ATD for development of Direct Attack Munition Affordable Seekers. The goal is to demonstrate an accuracy upgrade kit for GPS/INS guided weapons which will provide 3 meter CEP precision, by adding a very low cost fully strapped down imaging seeker. Insertion opportunities include JDAM. DCS has provided support in developing technical and management briefings to prepare for the ATD start in FY98. In conjunction with the IRFPA/FM program, DCS is also evaluating the technical suitability of uncooled sensors as a major cost reduction for the DAMASK seeker.

### 5.7.4 Precision Strike Navigator

Precision Strike Navigator is a planned insertion candidate for a P3I update to the JSOW. PSN is an ambitious program to develop high accuracy fiber optic gyros to significantly improve navigation accuracy while providing enhanced survivability in a GPS-jamming environment. DCS has provided support in developing both technical and programmatic briefings intended to develop, defend, and justify program funding profiles. DCS has also assisted in developing acquisition strategies which insure smooth transition of Government-developed technology to industry consistent with transition schedules into Navy weapons programs.

## 5.8 H-53 Systems Engineering

DCS performed a wide range of engineering studies for the application of improved avionics systems technologies into the H-53 helicopter and its systems. Specifically, DCS provided system engineering support to the H-53 ASPO (AIR-4.5.1.2) and H-53 Class Desk (AIR-4.1.1.2) for avionics upgrades and other associated aircraft improvements.

DCS performed program planning for a technology insertion and proof-of-concept demonstration for night airborne mine countermeasures (AMCM) using the MH-53E helicopter. The study would lead to elimination of the current daytime-only mission restriction through the incorporation of night vision devices, improved situational awareness displays, and improved human factors in the AMCM mission.

DCS supported the introduction of the Global Positioning System (GPS) navigation capability into the MH-53E as part of the integrated Navigation/Communication System (NCS) upgrade. DCS supported Operational Test planning and tracking of test deficiencies. We participated in the Government's validation/verification installation effort to resolve OT deficiencies and define the final production NCS configuration. In a related effort, DCS participated in the investigation of an electromagnetic vulnerability (EMV) problem with the NCS mission data loader. We helped formulate a test plan to isolate the specific fault mechanism and identify design measures that would eliminate the problem.

DCS worked with NRL's Plasma Physics Division to plan and conduct testing to measure the magnitude of electrostatic charge on the hovering CH-53E helicopter and the resultant electrostatic shock hazard to survivors in an over-water Search and Rescue (SAR) situation. The

helicopter is currently restricted from SAR pick-ups due to the effects of potential shock levels on humans. The study indicated that the hazard was less significant than previously believed, and reduction or elimination of the current mission restriction is under consideration.

DCS performed requirements analyses and performance specification development for an Integrated Mechanical Diagnostic System (IMDS) to monitor loads on the dynamics components of helicopter drive trains and dynamic components. The planned system will perform real-time monitoring and diagnosis of structural health of dynamic components to provide in-flight warning of imminent failures. It will also facilitate improved maintenance based upon actual usage rather than the traditional "elapsed time - remove and replace" approach. The resulting system is intended to be a common diagnostic system for all Navy helicopters.

### 5.9 Navy MAST Mounted Sight (NMMS)

The Naval Surface Warfare Center (NSWC - Crane Division) is responsible for depot level repair of the Navy Mast Mounted Sight (NMMS). The NMMS provides shipboard surveillance capability in both the visible and infrared portions of the electromagnetic spectrum. NSWC Crane is responsible for both electrical and electro-optical analysis and repair for the NMMS. As of the beginning of this program, they had electrical fault isolation capability with the DCS Sensor Electronics Test System (SETS), but no electro-optic test capability.

DCS was contracted to define, design, purchase, and deliver all hardware and software necessary for a complete operational Sensor Optical Test System (SOTS). SOTS was designed for stand-alone electro-optical acceptance test and analysis of the Navy Mast Mounted Sight (NMMS), Thermal Imaging Sensor (TIS), and Television Sensor (TVS). The SOTS was designed with inherent flexibility so that other EO sensors (both visible and thermal) can be added to its test repertoire with minimal system modifications. SOTS analyzes the electro-optical characteristics of the sensor under test through implementation of automated test procedures such as Sensor Uniformity, Signal Transfer Function (SiTF), Modulation Transfer Function (MTF), Distortion, Field of View (FOV), minimum Resolvable Contrast (MRC), Noise Equivalent Temperature Difference (NETD), Minimum Resolvable Temperature Difference (MRTD), and inter-sensor boresight. SOTS is also capable of verifying the condition of a repaired sensor through implementation of automated test procedures in accordance with applicable sensor electro-optical performance specifications.

DCS used in-house capabilities to design, assemble, and integrate SOTS. The SOTS optical test system, housed on a 5' x 8' vibration isolated optical bench, consists of a diffraction limited, 80" collimator with a 16" clear entrance aperture (F/5 system), thermal and visible sources, and a computer controlled array of up to 42 visible and thermal targets. SOTS also includes a six foot standard 19-inch rackmount enclosure and desk top, populated with a 200 MHz Pentium Pro computer controller running Windows NT 4.0, high resolution video frame grabber, MIL-STD-1553B Bus Controller, 200 MHz Digital Sampling Oscilloscope, and IEEE-488 bus controller for the thermal and visible sources and targets. DCS used the LabVIEW graphical programming language with a standardized hierarchical approach to write the hardware drivers and all test software for SOTS.

NSWC Crane now has flexible electrical (SETS) and electro-optical (SOTS) test capability for analysis and repair of electro-optical sensors.

#### 5.10 Miscellaneous Technology Transition Activities

Additional DCS studies, investigations and assistance included:

- Reviewed avionics R&D journals to maintain an awareness of opportunities for potential insertion/transition of the device technologies of interest; an example of importance to both military and civil spin-off uses is the recent application of GaAs MMIC technology to the design and manufacture of low-cost, hand-held GPS (Global Positioning System) receivers for navigation and geodetic survey.
- Analyzed technology insertion data for inclusion in materials for a presentation to industry on Naval Avionics 6.3 Technology Demonstrations; the data included active microwave array technology insertions via current and proposed efforts including MIMIC, ASAP (Airborne Shared Aperture Program), LPI Communications, MAFET (Microwave Analog Front End Technology), and AESA (Active Electronically-Scanned Array);
- Provided information for a 6.3 Naval Avionics briefing to be presented at a Common Avionics Workshop meeting;
- Attended a Technology Transfer Symposium to learn more about the new National Technology Initiative which promotes increased cooperation in R&D and expanded use of Cooperative Research and Development Agreements; DCS and NRL representatives discussed general technology transfer issues in an informal meeting since Federal Laboratories are now chartered to assist universities and the private sector in broadening the Nation's technology base;
- Prepared an overview of the DCS plan to address technologies (materials/devices/circuits) for viable microwave arrays; a presentation to NRL included an outline for manufacturability solutions and key factors for successful technology insertion;
- Reviewed the Raytheon/TI Draft Advanced Technology Plan for the HIPAS/M734 Small Caliber Fuze; comments on this plan were solicited from the Army Research Laboratory and a draft reply letter was prepared.

## **APPENDIX A**

Photographs of microchips, scanning electron micrographs of microchip defects, and infrared scans of microchips under bias conditions prepared under the Quality Assurance Activity.

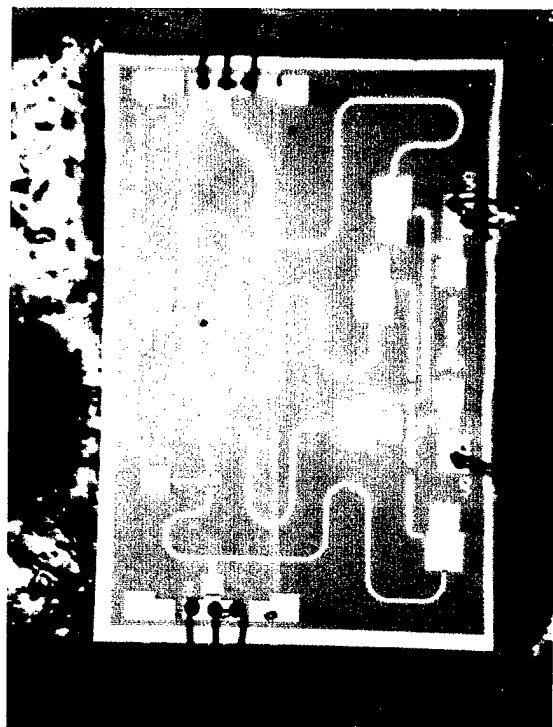

Photo 1. Sanders DMS-90 chip on wafer.

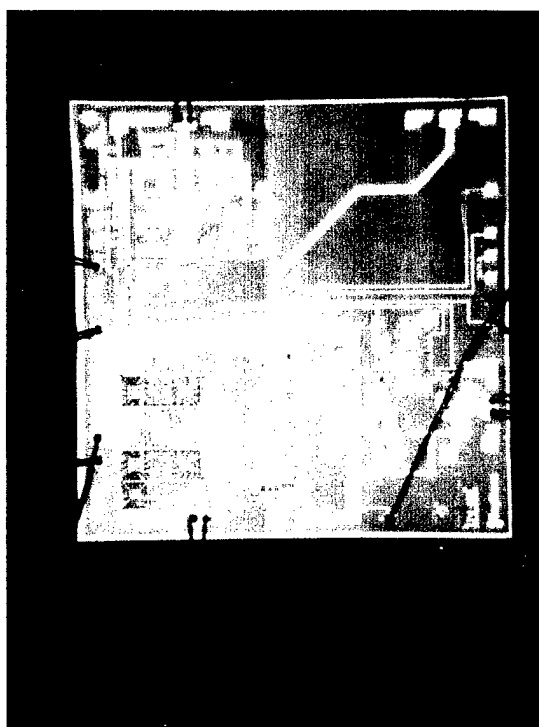

Photo 2. Raytheon TS-0028 chip on carrier.

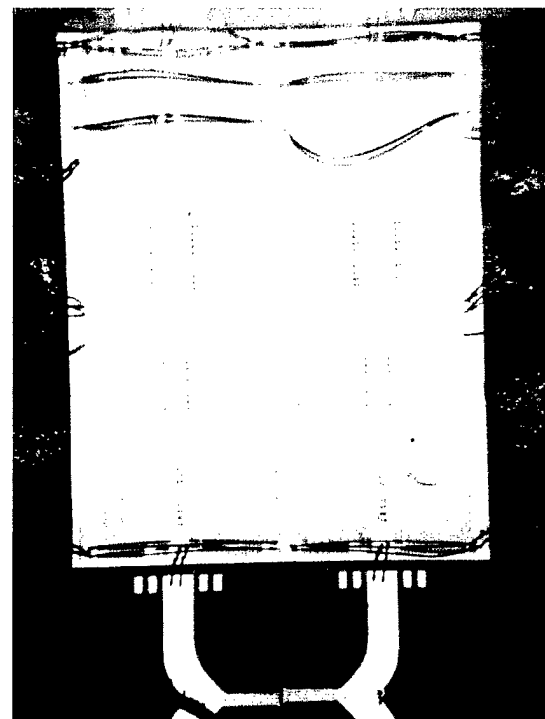

Photo 3. Sanders DMS-90 chip on wafer.

Photo 4. Raytheon MX-0031 chip on carrier.

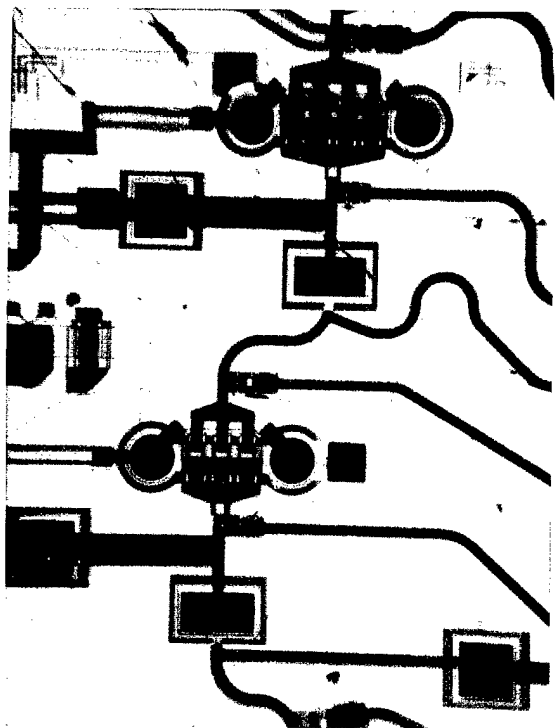

Photo 6. Cracks in microchip substrate.

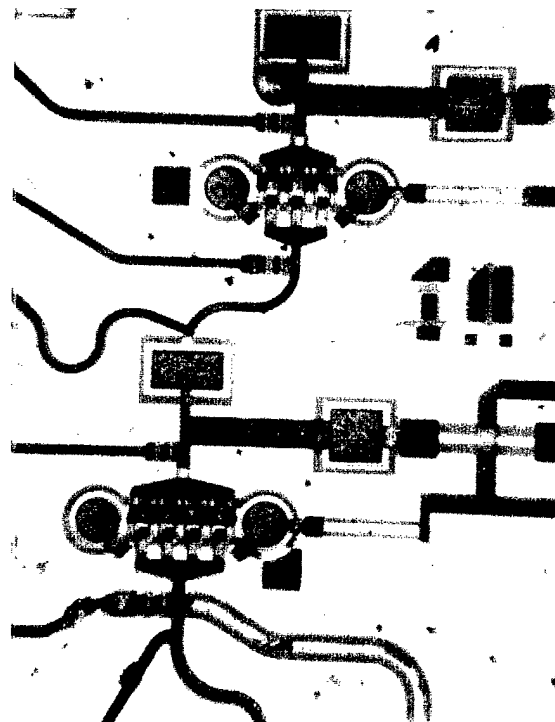

Photo 5. Dirt particles on microchip surface.

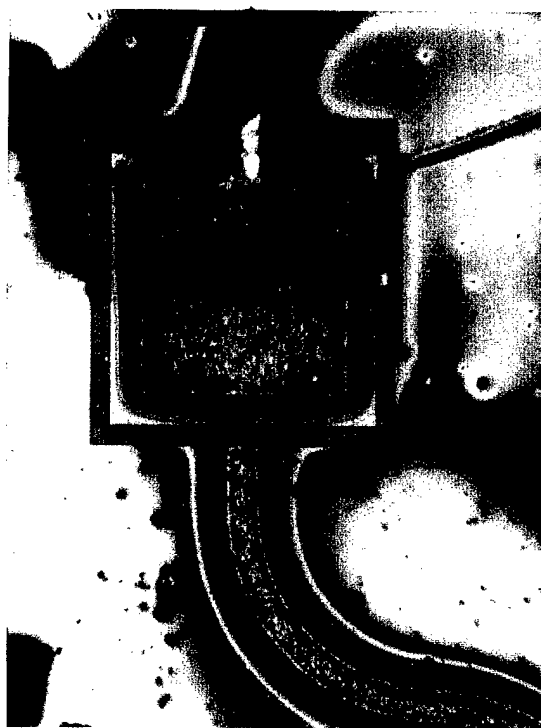

Photo 8. Chemical residue on chip surface.

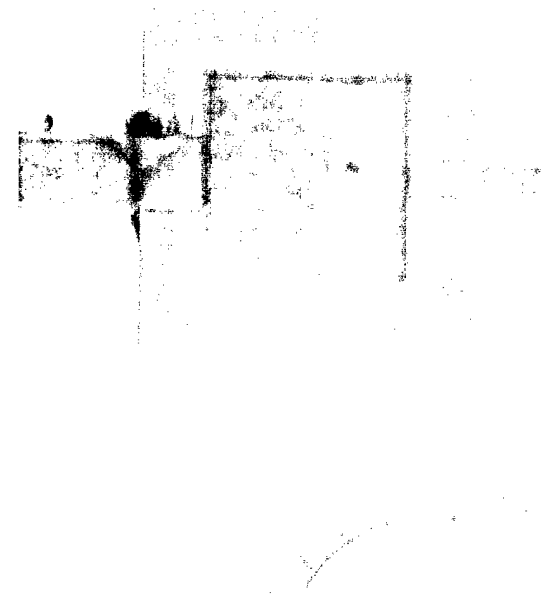

Photo 7. Possible short circuit.

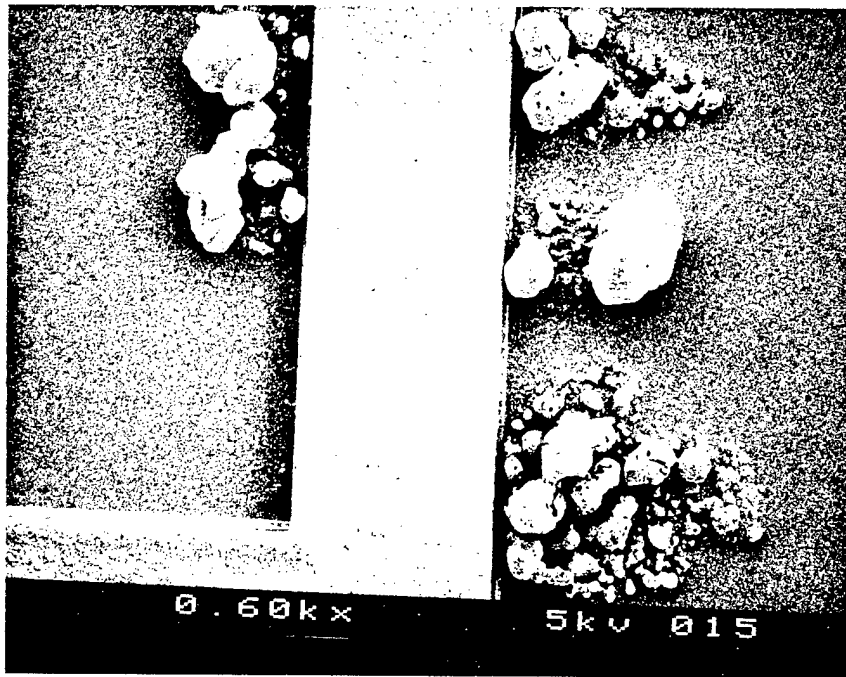

Photo 9. Surface defects along transmission line at 600X magnification.

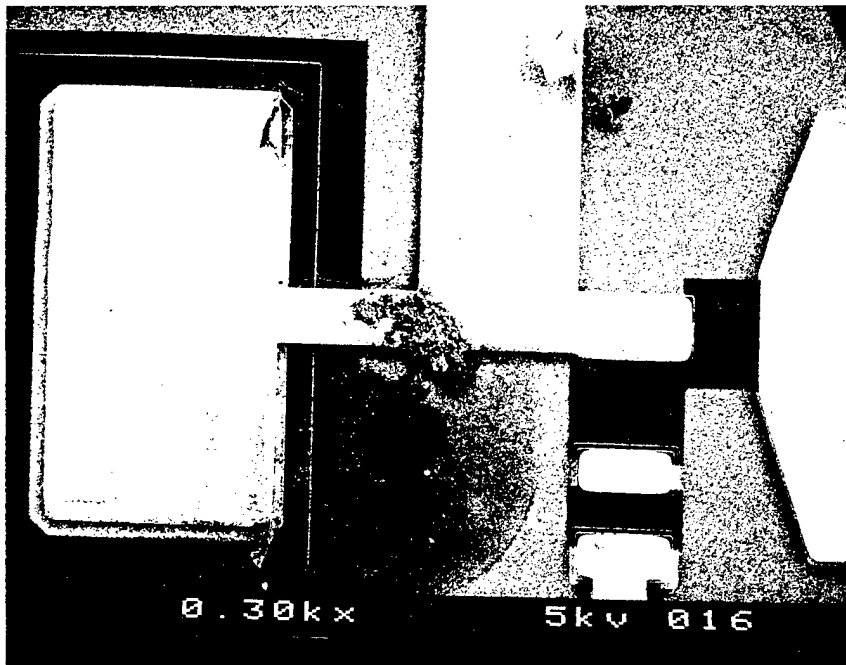

Photo 10. Short circuit near capacitor at 300X magnification.

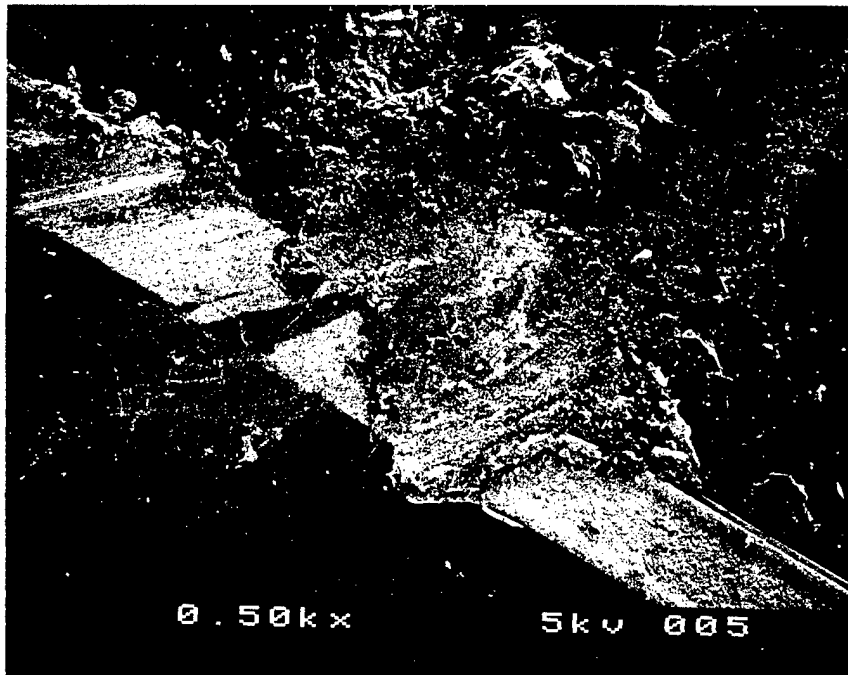

Photo 11. Scratch across transmission line and dirt on chip at 500X magnification.

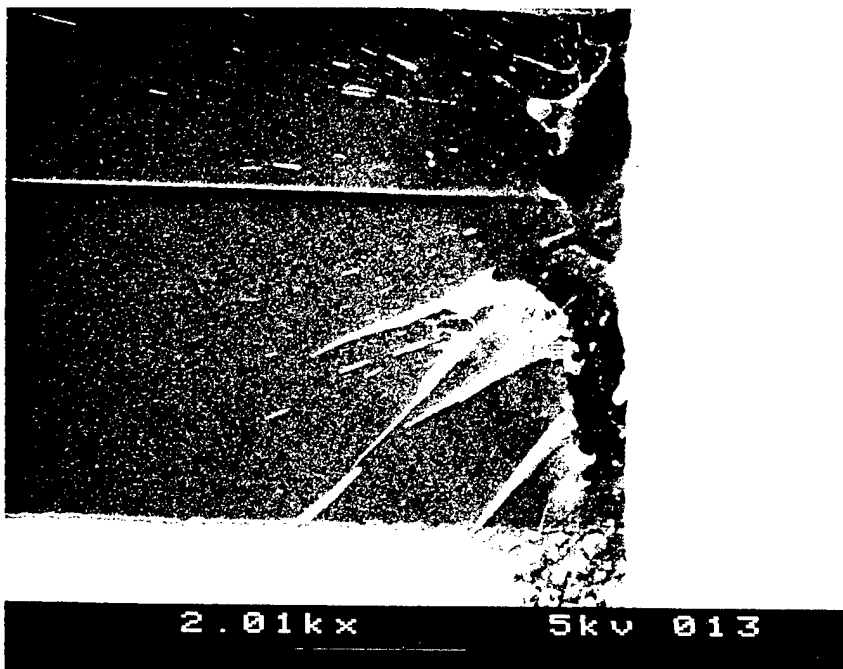
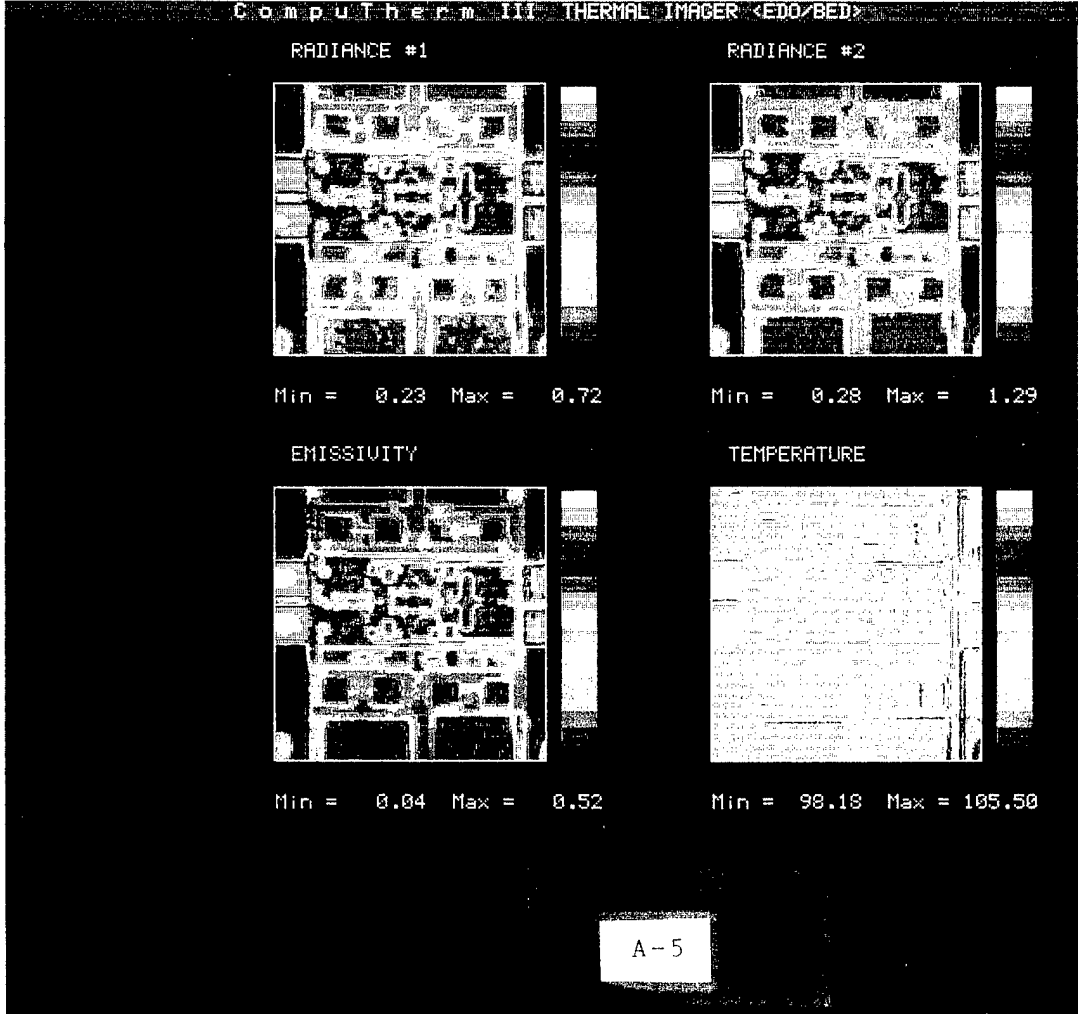
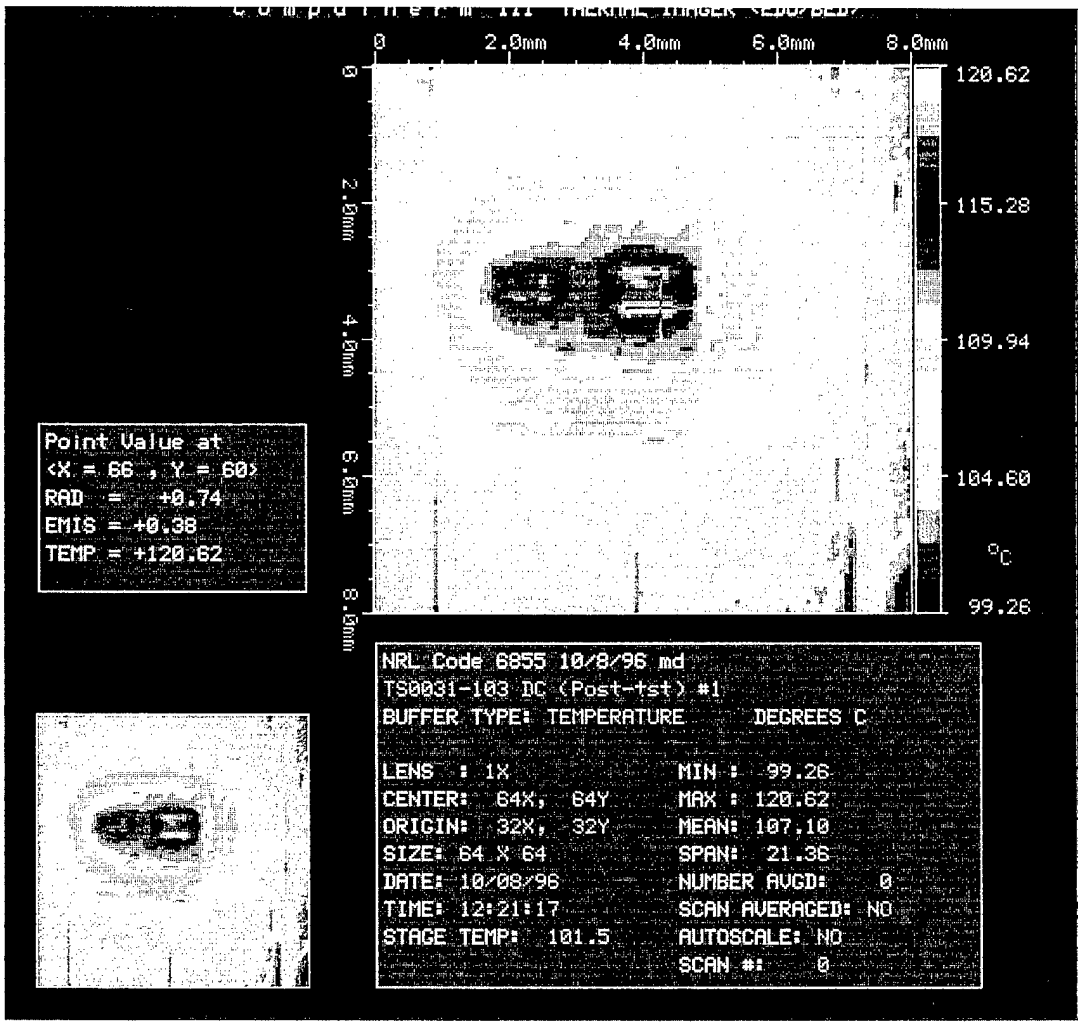

Photo 12. Short circuit and ejecta at 2000X magnification.



Photograph 13. Typical infrared scan of Raytheon PHEMT two-stage amplifier (Device number TS-0031-103) taken after life-testing. The scan was taken using the 1X lens at a scan of 64 X 64. Lower image shows the four preliminary scans needed to create the final image, including the two radiance scans taken above and below the final 100°C temperature, the calculated emissivity scan, and the unpowered temperature scan.

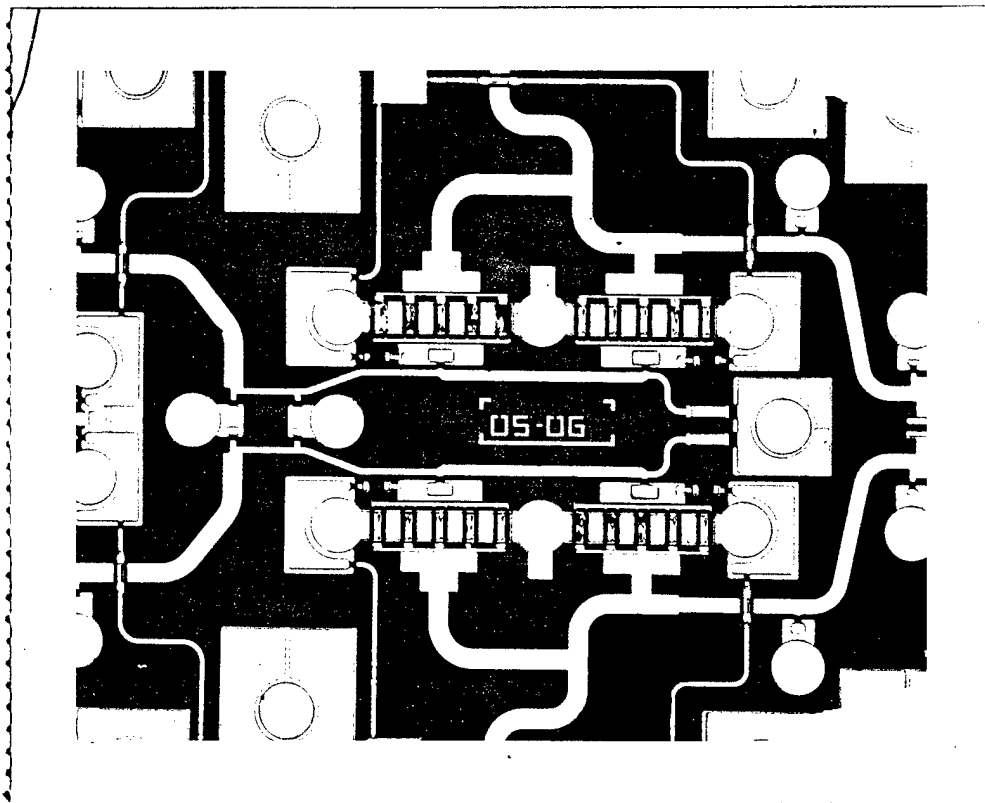

Photo 14. Raytheon Device TS-0031-031 (Post test) at 5X magnification.

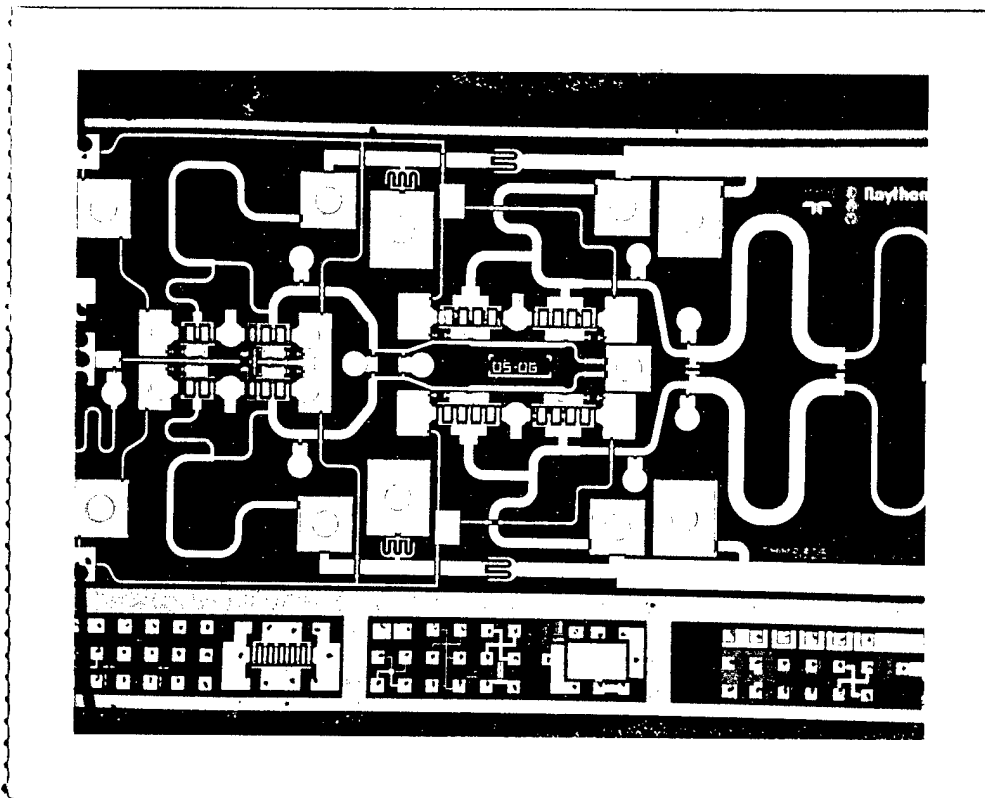

Photo 15. Raytheon Device TS-0031-031 (Post test) at 2.5 magnification.

## **APPENDIX B**

Detailed and complete list of all deliverables provided to NRL and NAVAIR during the 1 October 1992 through 20 November 1996 period of performance.

**NRL TECHNICAL AND FINANCIAL PROGRESS REPORTS**  
**INDEX OF DCS DELIVERABLES**

| <u>Date Delivered</u>               | <u>Title/Topic</u>   | <u>Author(s)</u> | <u>Recipient(s)</u>                          |
|-------------------------------------|--|------------------|--|
| <b>1 OCTOBER - 31 DECEMBER 1992</b> |  |                  |  |
| 04 November 92                      | Report - Adv. Microelectronics Techn. Qual. Rel. Log Workshop                                      | Ron Wade         | Webb, 6850<br>Anderson, 6855                 |
| 05 November 92                      | Letter to R-C; Comments on AN/ARC-210(V) ECCM Radio EI and ET                                      | B. Goodwin       | Parks, 546X1                                 |
| 05 November 92                      | Distribution List for EW Brassboard  | Ron Wade         | Sleger, 6801                                 |
| 05 November 92                      | GaAs Symposium Report  | Ron Wade         | Sleger, 6801                                 |
| 02 December 92                      | AAS&T Viewgraph  | Jack Snead       | Caposell, 546TD                              |
| 02 December 92                      | Draft AIRTASK  | Jack Snead       | Caposell, 546TD                              |
| 04 December 92                      | PR FAR (Pg 1) for Contract N00019-91-C-0191  | Garnett Bailey   | Glista, 546TE                                |
| 04 December 92                      | PR FAR (Pg 1) for Contract N00019-80-C-0169  | Garnett Bailey   | Glista, 546TE                                |
| 14 December 92                      | Comments on BAA 93-02-AAKE (MW Packaging-Primary Ph)   | Ron Wade         | Sleger, 6801                                 |
| 15 December 92                      | Multiple letters for NAVAIR (AIR-546X1) approval of data items - Contract N00019-84-C-0128, P00003 | W. Spilker       | Parks, 546X1                                 |
| 16 December 92                      | Comments on BAA (Support Techn Phase) - MW Packaging   | Ron Wade         | Sleger, 6801                                 |
| 17 December 92                      | List of GaAs MMIC Amplifiers <6 GHz  | Ron Wade         | Webb, 6850                                   |
| 21 December 92                      | FY-93 Budget Planning Sheet for 63217N/W0446 AAS&T   | Jack Snead       | Caposell, 546TD                              |
| 21 December 92                      | Draft AIRTASK  | Jack Snead       | Caposell, 546TD                              |
| <b>1 JANUARY - 31 MARCH 1993</b>    |  |                  |  |
| 06 January 93                       | Mantech Meeting - T/R Modules  | Ron Wade         | Sleger, 6801<br>Webb, 6850<br>Anderson, 6855 |
| 06 January 93                       | List of Phase 3 & Other MIMIC Contracts  | Ron Wade         | Sleger, 6801<br>Webb, 6850<br>Anderson, 6855 |
| 06 January 93                       | 1993 Symposia  | Ron Wade         | Sleger, 6801<br>Webb, 6850<br>Anderson, 6855 |
| 14 January 93                       | AAS&T FY-93 History Inputs   | Jack Snead       | Caposell, 546TD                              |
| 15 January 93                       | RFP; AN/ARC-210(V) ECCM Radio, P <sup>3</sup> I for DALs, Link 4A/Link II and DAMA SATCOM          | W. Spilker       | Roney, PMA-209H                              |

| <u>Date Delivered</u> | <u>Title/Topic</u>   | <u>Author(s)</u> | <u>Recipient(s)</u> |
|-----------------------|--|------------------|---------------------|
| 15 January 93         | RFP; AN/ARC-210(V) ECCM Radio, P <sup>3</sup> I for DAL5   | W. Spilker       | Roney, PMA-209H     |
| 15 January 93         | RFP; AN/ARC-210(V) ECCM Radio, P <sup>3</sup> I for SATCOM   | W. Spilker       | Roney, PMA-209H     |
| 15 January 93         | RFP; AN/ARC-210(V) ECCM Radio, P <sup>3</sup> I for Link 4A/Link II  | W. Spilker       | Roney, PMA-209H     |
| 15 January 93         | RFP; AN/ARC-210(V) ECCM Radio, P <sup>3</sup> I for DAL5, Link 4A/Link II and DAMA SATCOM (with embedded DAMA modem, downsized, and with embedded ANDVT) | W. Spilker       | Roney, PMA-209H     |
| 19 January 93         | Summary of AIR-546T FY-92 Accomplishments  | M. Daniel        | Caposell, 546TD     |
| 26 January 93         | CDR Report - ITT   | Ron Wade         | Sleger, 6801        |
| 01 February 93        | Report on TI ASAP Meeting  | Ron Wade         | Sleger, 6801        |
| 01 February 93        | Report on Westinghouse ASAP Meetings   | Ron Wade         | Sleger, 6801        |
| 01 February 93        | CDR Report - ITT   | Ron Wade         | Sleger, 6801        |
| 04 February 93        | Checklist for CDRL Item A011   | Ron Wade         | Sleger, 6801        |
| 04 February 93        | Comments on the HIPAS Fuze Technology Demonstration Development Plan   | Ron Wade         | Sleger, 6801        |
| 05 February 93        | Comments on Advanced Technology Development Plan (Packaging & Assembly Supplement)   | Ron Wade         | Sleger, 6801        |
| 05 February 93        | Comments on ASAP Demonstrator Development Plan   | Ron Wade         | Sleger, 6801        |
| 05 February 93        | X-Ray Lithography Workshop Trip Report   | M. Daniel        | Sleger, 6801        |
| 05 February 93        | DALP Capsule Summaries, Version 4.0  | M. Daniel        | Sleger, 6801        |
| 08 February 93        | Comments on Q-Band VCO MMIC Demonstrator Development Plan  | Ron Wade         | Sleger, 6801        |
| 08 February 93        | Comments on Micro-TWT Driver Module Demonstrator Development Plan  | Ron Wade         | Sleger, 6801        |
| 16 February 93        | Checklist for Process Line Validation Plans  | Ron Wade         | Sleger, 6801        |
| 16 February 93        | Comments on Lockheed Sanders 0.25 $\mu$ m LN Process Validation Plan   | Ron Wade         | Sleger, 6801        |
| 16 February 93        | Comments on TI 0.25 $\mu$ m LN Process Validation Plan   | Ron Wade         | Sleger, 6801        |
| 17 February 93        | Memorandum: Overdue IBM CDRL Deliverables  | M. Daniel        | Sleger, 6801        |
| 17 February 93        | Memorandum: Overdue IBM CDRL Deliverables  | M. Daniel        | Henson, ADPO-48C    |
| 17 February 93        | PR FAR (Pg 1) for Contract N00019-91-C-0145  | Garnett Bailey   | Cudd, 546TH         |
| 24 February 93        | PR FAR (Pg 1) for Contract N00014-89-C-2238  | Garnett Bailey   | Henson, ADPO-48C    |

| <u>Date Delivered</u>         | <u>Title/Topic</u>   | <u>Author(s)</u> | <u>Recipient(s)</u> |
|-------------------------------|--|------------------|---------------------|
| 26 February 93                | DALP program participants Phone and Address List, Edition 2 (Draft)                              | M. Daniel        | Sleger, 6801        |
| 16 March 93                   | Common Plan vs. JV Plan (0.5µm ii process)   | Ron Wade         | Dietrich, 6856      |
| 18 March 93                   | Listing, AN/ARC-210(V) proposed specifications changes (Receiver Transmitter and Antenna)        | B. Goodwin       | Parks, 546X1        |
| 19 March 93                   | PR FAR (Pg 1) for Contract N00019-92-C-0064  | Garnett Bailey   | Henson, ADPO-48C    |
| 22 March 93                   | Proposed RASSP Demonstrations  | Ron Wade         | Borsuk, 6800        |
| 22 March 93                   | RASSP Program Navy SSEB Participants   | Ron Wade         | Borsuk, 6800        |
| 23 March 93                   | Task 3 Test Plan - Recommendation for Approval   | Ron Wade         | Anderson, 6855      |
| 24 March 93                   | 63217N/W0446 1 Mar 93 Program Execution Plan   | Jack Snead       | Caposell, 546TD     |
| 24 March 93                   | 63217N/W0446 15 Mar 93 ONR Review Charts   | Jack Snead       | Caposell, 546TD     |
| 30 March 93                   | Summary Report on MIMIC Phase 2 Executive Reviews  | Ron Wade         | Borsuk, 6800        |
| <b>1 APRIL - 30 JUNE 1993</b> |  |                  |                     |
| 02 April 93                   | PR FAR (Pg 1) for Contract N00019-91-C-0145  | Garnett Bailey   | Cudd, 546TH         |
| 08 April 93                   | Data on visual inspection of EG6010, TI Standard Evaluation Circuits (SEC) prior to life testing | S. Kadambi       | Roussos, 6835       |
| 09 April 93                   | Compilation of 35 MIMIC Phase 1 chips  | Ron Wade         | Abrams, 6840        |
| 09 April 93                   | Compilation of 83 MIMIC Phase 2 and other chips  | Ron Wade         | Abrams, 6840        |
| 12 April 93                   | Memorandum: Review of Quarterly Reports (CDRL A005) under IBM contract #N00019-91-C-0207         | M. Daniel        | Sleger, 6801        |
| 19 April 93                   | Non-Acquisition 6.3 Program Information  | Jack Snead       | Caposell, 546TD     |
| 19 April 93                   | Naval Avionics Technology Briefing Viewgraphs  | Jack Snead       | Caposell, 546TD     |
| 28 April 93                   | Labor Rates Statement (CEC) (Fax)  | Ron Wade         | Marshall, 546T      |
| 30 April 93                   | NRL FY-93 AIRTASK for DALP Program   | M. Daniel        | Borsuk, 6800        |
| 30 April 93                   | Memorandum/Point(s) of Contact Designation Form  | Ron Wade         | Caposell, 546TD     |
| 13 May 93                     | PR FAR (Pg 1) for Contract N00019-92-C-0062  | Garnett Bailey   | Henson, ADPO-48C    |
| 13 May 93                     | PR FAR (Pg 1) for Contract N00019-92-C-0152  | Garnett Bailey   | Henson, ADPO-48C    |
| 18 May 93                     | NAWC-WD-CL FY-93 AIRTASK for DALP Program  | M. Daniel        | Henson, ADPO-48C    |
| 18 May 93                     | NAWC-AD Warminster FY-93 AIRTASK for DALP Program  | M. Daniel        | Henson, ADPO-48C    |

| <u>Date Delivered</u>               | <u>Title/Topic</u>  | <u>Author(s)</u> | <u>Recipient(s)</u> |
|-------------------------------------|---|------------------|---------------------|
| 18 May 93                           | NCCOSC FY-93 AIRTASK for DALP Program   | M. Daniel        | Henson, ADPO-48C    |
| 18 May 93                           | NRL Radar Review  | Ron Wade         | Sleger, 6801        |
| 20 May 93                           | Navy MAFET Planning Viewgraphs  | Ron Wade         | Sleger, 6801        |
| 20 May 93                           | Post MIMIC Workshop Viewgraphs  | Ron Wade         | Sleger, 6801        |
| 20 May 93                           | Potential Military and Commercial Applications                                    | Ron Wade         | Sleger, 6801        |
| 20 May 93                           | Briefing to all PMAs on AN/ARC-210(V) ECCM Radio P <sup>3</sup> I options         | W. Spilker       | Roney, PMA-209H     |
| 24 May 93                           | Minutes, AN/ARC-210(V) ECCM Radio P <sup>3</sup> I Options Meeting with user PMAs | W. Spilker       | Roney, PMA-209H     |
| 26 May 93                           | PR FAR (Pg 1) for Contract N00019-92-K-0021 modification                          | Garnett Bailey   | Henson, ADPO-48C    |
| 26 May 93                           | Delivery Schedule to Contract N00019-92-K-0021 modification                       | Garnett Bailey   | Henson, ADPO-48C    |
| 01 June 93                          | PMR Viewgraphs  | S. Kadambi       | Caposell, ADPO-48   |
| 10 June 93                          | Draft AIRTASK for NRL   | Garnett Bailey   | Cudd, 546TH         |
| 16 June 93                          | Draft SAC R&D Questions   | Jack Snead       | Caposell, 546TD     |
| 16 June 93                          | Visual analysis data of 45 EG8310 chips   | S. Kadambi       | Rousson, 6855       |
| <b>1 JULY - 30 SEPTEMBER 1993</b>   |   |                  |                     |
| 28 July 93                          | Vacuum Electronics Review Data  | Bruce Walpole    | Parker, 6840        |
| 30 August 93                        | OSD S&T Review Viewgraphs   | Jack Snead       | Caposell, 546TD     |
| 30 August 93                        | Program Execution Plan for P.E. 0603217N  | Jack Snead       | Caposell, 546TD     |
| 01 September 93                     | Airtask for NAWC-AD-Warminster  | Jack Snead       | Caposell, 546TD     |
| 01 September 93                     | Airtask for NAWC-AD-Indianapolis  | Jack Snead       | Caposell, 546TD     |
| 01 September 93                     | Airtask for NRL   | Jack Snead       | Caposell, 546TD     |
| 01 September 93                     | Airtask for Naval Postgraduate School   | Jack Snead       | Caposell, 546TD     |
| 09 September 93                     | MIMIC Phase 2 Chip Deliverables   | Ron Wade         | Borsuk, 6800        |
| 22 September 93                     | FY91-93 Actual Funding to Microwave Tube Industry                                 | Bruce Walpole    | Parker, 6840        |
| 24 September 93                     | ITT Technology Demonstration Report   | Ron Wade         | Webb, 6850          |
| <b>1 OCTOBER - 31 DECEMBER 1993</b> |   |                  |                     |
| 18 October 93                       | FY 91-93 NRL Vendor Funding   | Bruce Walpole    | Parker, 6840        |
| 12 November 93                      | Module Size Survey  | Ron Wade         | Sleger, 6801        |
| 02 December 93                      | MAFET Dual-Use Technology   | Ron Wade         | Sleger, 6801        |

| <u>Date Delivered</u>             | <u>Title/Topic</u>   | <u>Author(s)</u> | <u>Recipient(s)</u>                  |
|-----------------------------------|--|------------------|--------------------------------------|
| <b>1 JANUARY - 31 MARCH 1994</b>  |  |                  |                                      |
| 11 January 94                     | Memorandum of Symposium, 15-18 December 93                           | S. Kadambi       | Caposell, ADPO-48                    |
| 08 February 94                    | Report - HDMP Review   | Ron Wade         | Sleger, 6801                         |
| 08 February 94                    | DALP Acquisition Plan (AP) No. AIR-94-000                            | M. Daniel        | Peckerar, 6860                       |
| 09 March 94                       | Summary of Plastic IC Status   | Ron Wade         | Sleger, 6801                         |
| 09 March 94                       | Comments on Chip & Module Test Plan                                  | Ron Wade         | Dietrich, 6856                       |
| 14 March 94                       | FY 94 RDT&E,N Deficiency Impact Statement                            | Jack Snead       | Caposell, ADPO-48                    |
| 22 March 94                       | Review of Loral/IBM Aligner Task Deliverables for Schedule Variances | M. Daniel        | Henson, ADPO-48C                     |
| <b>1 APRIL - 30 JUNE 1994</b>     |  |                  |                                      |
| 28 April 94                       | Comments on Lockheed Sanders Task 3 Test Plan                        | Ron Wade         | Anderson, 6800<br>Dietrich<br>Sleger |
| 28 April 94                       | Comments on TI 0.25 $\mu$ m Power PHEMT Validation Plan              | Ron Wade         | Anderson, 6800<br>Dietrich<br>Sleger |
| 28 April 94                       | Viewgraphs and Notes on U.S. Microwave Market                        | Ron Wade         | Anderson, 6800<br>Dietrich<br>Sleger |
| 17 May 94                         | Power Module Figures of Merit  | Ron Wade         | Sleger, 6801                         |
| 19 May 94                         | GaAs MMIC Module Report  | Ron Wade         | Sleger, 6801                         |
| 16 June 94                        | List of systems/applications for 0.5 $\mu$ m ii                      | Ron Wade         | Anderson, 6855                       |
| 16 June 94                        | Comments on PHEMT Process Demonstration Plan                         | Ron Wade         | Dietrich, 6856                       |
| 21 June 94                        | MIMIC Phase 2 Chips  | Ron Wade         | Webb, 6850                           |
| <b>1 JULY - 30 SEPTEMBER 1994</b> |  |                  |                                      |
| 05 July 94                        | F-22 EW Brassboard Test Plan Recommendation                          | Ron Wade         | Dietrich, 6856                       |
| 05 July 94                        | GEN-X Brassboard Test Plan Recommendation                            | Ron Wade         | Dietrich, 6856                       |
| 26 July 94                        | EBS Memo   | Ron Wade         | Sleger, 6801<br>Anderson, 6855       |
| 26 July 94                        | System Points of Contact   | Ron Wade         | Sleger, 6801<br>Anderson, 6855       |
| 24 August 94                      | Title III GaAs Wafer Project - Overview Report                       | Ron Wade         | Sleger, 6801                         |

| <u>Date Delivered</u>               | <u>Title/Topic</u>   | <u>Author(s)</u> | <u>Recipient(s)</u>        |
|-------------------------------------|--|------------------|----------------------------|
| <b>1 OCTOBER - 31 DECEMBER 1994</b> |  |                  |                            |
| 3 October 94                        | FY-95 DALP, HDMP & MIMIC AIRTASKs to NRL, NAWC-Warminster, NAWC-Indianapolis, NCCOSC, NAWC-China Lake, and NSWC-Dahlgren | M. Daniel        | Caposell, ADPO-48          |
| 21 October 94                       | Evaluation of High Purity Silicon Boule for IR and Optical Sensor Applications   | M. Daniel        | Anderson, 6855             |
| 10 November 94                      | MIMIC PR for Raytheon/TI JV  | M. Daniel        | Marshall, ADPO-48D         |
| 30 November 94                      | Software Reliability Library Search and Brief  | M. Daniel        | Anderson, 6855             |
| 1 December 94                       | MAFET Software Reliability Brief   | M. Daniel        | Anderson, 6855             |
| 13 December 94                      | Inspection of Standard Evaluation Circuits (SECs) Texas Instruments Low Noise Amplifiers # TI-EG6356 (Report)            | M. Daniel        | Anderson, 6855             |
| 14 December 94                      | MIMIC Compact Software Inc. Incremental Funding PR   | M. Daniel        | Marshall, ADPO-48D         |
| 19 December 94                      | MEMO: MAFET Reliability Participation  | M. Daniel        | Anderson, 6855             |
| <b>1 JANUARY - 31 MARCH 1995</b>    |  |                  |                            |
| 4 January 95                        | DALP FY-94 Acquisition Plan (Draft) Version 2.0  | M. Daniel        | Henson, ADPO-48C           |
| 13 January 95                       | Report - T/R Module MT Program   | Ron Wade         | Sleger, 6801<br>Webb, 6850 |
| 13 January 95                       | Report - HDMP Reviews  | Ron Wade         | Sleger, 6801<br>Webb, 6850 |
| 25 January 95                       | Inspection of Standard Evaluation Circuits (SECs) Raytheon Power PHEMTs # TS-0031-00-A (Report)                          | M. Daniel        | Anderson, 6855             |
| 14 February 95                      | MAFET Conference Participants List   | M. Daniel        | Anderson, 6855             |
| 16 February 95                      | MAFET CDRL Package (Generic)   | M. Daniel        | Marshall, ADPO-48D         |
| 6 March 95                          | AIR-4.5T Logo (Computer Graphic Artwork)   | M. Daniel        | Caposell, ADPO-48          |
| 21 March 95                         | M&S and University DALP Funding, White Paper   | M. Daniel        | Caposell, ADPO-48          |
| 23 March 95                         | MIMIC Raytheon/TI Joint-Venture PR Mod   | M. Daniel        | Marshall, ADPO-48D         |
| <b>1 APRIL - 30 JUNE 1995</b>       |  |                  |                            |
| 1 April - 30 June 95                | Numerous versions of the MAST FY95 and 5-Year Execution Plans  | Bill Bunker      | Caposell, ADPO-48          |
| 1 April - 30 June 95                | Mast Briefing Charts   | Bill Bunker      | Caposell, ADPO-48          |

| <u>Date Delivered</u>             | <u>Title/Topic</u>   | <u>Author(s)</u> | <u>Recipient(s)</u>                              |
|-----------------------------------|--|------------------|--|
| 3 April 95                        | MAFET Funding Recommendations  | Ron Wade         | Dietrich, 6856                                   |
| 4 April 95                        | Analysis of TI Cost Proposal   | Ron Wade         | Dietrich, 6856                                   |
| 4 April 95                        | Recommendations for MIMIC Test Plan  | Ron Wade         | Dietrich, 6856                                   |
| 12 April 95                       | MAFET Distribution Lists (3 sets)  | Ron Wade         | Dietrich, 6856<br>Newman, 6851<br>Anderson, 6855 |
| 14 April 95                       | PID - Produce a magnification to 0.12 microns  | G. Bailey        | Henson, ADPO-48C                                 |
| 2 May 95                          | MMACE Workshop Trip Report   | M. Daniel        | Abrams, 6844                                     |
| 4 May 95                          | Recommendations on Raytheon/TI JV corrective actions to validation plan  | Ron Wade         | Dietrich, 6856                                   |
| 9 May 95                          | Inspection of Standard Evaluation Circuits (SECs) Raytheon Low Noise Amplifiers #LN-0042-02 (Report)           | M. Daniel        | Anderson, 6855                                   |
| 30 May 95                         | MAFET Contract, Westinghouse SOW   | M. Daniel        | Anderson, 6855                                   |
| 31 May 95                         | PID - Extends capability down  | G. Bailey        | Henson, ADPO-48C                                 |
| 6 June 95                         | MAFET CDRL Address List  | M. Daniel        | Marshall, ADPO-48D                               |
| 6 June 95                         | Inspection of Standard Evaluation Circuits (SECs) Raytheon Power Amplifiers #TS-0020-00-A (Report)             | M. Daniel        | Anderson, 6855                                   |
| 8 June 95                         | Draft Statements of Work (6) for MAFET procurements  | Ron Wade         | Dietrich, 6856                                   |
| 8 June 95                         | PID - Extends Phase II extension   | G. Bailey        | Henson, ADPO-48C                                 |
| 27 June 95                        | S-Parameter Measurements of Radiation Exposed Two-Stage PHEMT Power Amplifier SECs Part Number EG6350 (Report) | M. Daniel        | Anderson, 6855                                   |
| 28 June 95                        | PID - Produce a collimator fix   | G. Bailey        | Henson, ADPO-48C                                 |
| 28 June 95                        | Annual VE Review Report  | B. Walpole       | Parker, 6840                                     |
| 30 June 95                        | Draft SBIR Package for CPU Technology  | Bill Bunker      | Caposell, ADPO-48                                |
| <b>1 JULY - 30 SEPTEMBER 1995</b> |  |                  |  |
| 05 July 95                        | P.I.D. - Provides funds for FY95 burden rate adjustments for Loral   | Garnett Bailey   | Henson, ADPO-48C                                 |
| 17 July 95                        | P.I.D. - Modifies options part of MMD  | Garnett Bailey   | Henson, ADPO-48C                                 |

| <u>Date Delivered</u>               | <u>Title/Topic</u>  | <u>Author(s)</u> | <u>Recipient(s)</u>               |
|-------------------------------------|---|------------------|-----------------------------------|
| 18 July 95                          | Audit Report - TI Cost Proposal   | Ron Wade         | Glenn Marshall,<br>NAWC-AD        |
| 28 July 95                          | Technical Review - Lockheed Martin  | Ron Wade         | Glenn Marshall,<br>NAWC-AD        |
| 31 July 95                          | Cost Estimate - Raytheon/TI JV  | Ron Wade         | Glenn Marshall,<br>NAWC-AD        |
| 08 August 95                        | MAFET Presentation  | Ron Wade         | Sleger, 6801                      |
| 17 August 95                        | P.I.D. - Provides funds for FY95 burden rate adjustments for Loral - Rev. 2                       | Garnett Bailey   | Henson, ADPO-48C                  |
| 06 September 95                     | Inspection of TI Two-Stage PHEMT Power Amplifier SECs - Report                                    | Maurice Daniel   | Anderson, 6855                    |
| 08 September 95                     | Potential MAFET Transitions   | Ron Wade         | Borsuk, 6800<br>Caposell, ADPO-48 |
| 15 September 95                     | Re-Inspection of Raytheon Two-Stage PHEMT Power Amplifier SECs After Destructive Testing - Report | Maurice Daniel   | Anderson, 6855                    |
| 15 September 95                     | MAFET Progress Report   | Ron Wade         | Sleger, 6801                      |
| 28 September 95                     | MPM Usage Survey/Insertions   | Bruce Walpole    | Abrams, 6844                      |
| July - Sept 95                      | Several versions of MAST Execution Plan   | Bill Bunker      | Caposell, ADPO-48                 |
| July - Sept 95                      | Numerous viewgraphs for MAST Briefings  | Bill Bunker      | Caposell, ADPO-48                 |
| <b>1 OCTOBER - 31 DECEMBER 1995</b> |   |                  |                                   |
| 01 October 95                       | Updated mailing/phone list  | Bruce Walpole    | Parker, 6840                      |
| 06 October 95                       | High Density Microwave Packaging Summary Report to NRL  | Ron Wade         | Webb, 6850                        |
| 08 October 95                       | Assessment of Lockheed Martin MAFET Cost proposal   | Ron Wade         | Dietrich, 6856                    |
| 10 October 95                       | Updated spreadsheet on FY-96 Funding Requirements   | Bruce Walpole    | Abrams, 6844                      |
| 10 October 95                       | Assessment of Raytheon/TI MAFET cost proposal   | Ron Wade         | Dietrich, 6856                    |
| 15 October 95                       | MPM/MMPM Insertions through 13 October, 95  | Bruce Walpole    | Abrams, 6844                      |
| 16 October 95                       | Updated Address list for MPM/MMACE/DFLC Programs including e-mail addresses                       | Bruce Walpole    | Abrams, 6844                      |
| 17 October 95                       | MAFET Progress Report (Westinghouse)  | Ron Wade         | Dietrich, 6856                    |
| 19 October 95                       | P.I.D. - added FY96 funds to AT&T contract  | Garnett Bailey   | Henson, ADPO-48C                  |
| 19 October 95                       | P.I.D. - added FY96 funds to Loral contract   | Garnett Bailey   | Henson, ADPO-48C                  |
| 19 October 95                       | MAFET Progress Report (Lockheed Martin)   | Ron Wade         | Dietrich, 6856                    |

| <u>Date Delivered</u>            | <u>Title/Topic</u>   | <u>Author(s)</u> | <u>Recipient(s)</u> |
|----------------------------------|--|------------------|---------------------|
| 19 October 95                    | Re-Inspection of Texas Instruments Three-Stage Ku-Band MESFET Driver Amplifier SECs After Life Testing | Maurice Daniel   | Anderson, 6855      |
| 20 October 95                    | Comments/recommendations on Raytheon/TI JV draft final report  | Ron Wade         | Webb, 6850          |
| 23 October 95                    | New spreadsheet on FY96 funding requirements   | Bruce Walpole    | Abrams, 6844        |
| 24 October 95                    | Completed list of Code 6840 contracts and COTR's with additional management funding required in FY96   | Bruce Walpole    | Parker, 6840        |
| 26 October 95                    | MAFET Progress Report (EMS Technologies)   | Ron Wade         | Dietrich, 6856      |
| 12 November 95                   | MAFET Program Descriptions   | Ron Wade         | Marshall, ADPO-48D  |
| 20 November 95                   | Data on HBT & MESFET power added efficiencies  | Ron Wade         | Dietrich, 6856      |
| 02 December 95                   | MAFET presentation material  | Ron Wade         | Marshall, ADPO-48D  |
| 04 December 95                   | P.I.D. - initiated a contract to demonstrate a modular advanced lithography subsystem                  | Garnett Bailey   | Henson, ADPO-48C    |
| 06 December 95                   | Provided MAST PMR briefing with copies for distribution  | Garnett Bailey   | Caposell, ADPO-48   |
| 07 December 95                   | Release of FY96 OSD-Deferred Funds (MAST)  | Bill Bunker      | Caposell, ADPO-48   |
| 10 December 95                   | Compilation of MAFET Thrust #2 insertions  | Ron Wade         | Dietrich, 6856      |
| 12 December 95                   | P.I.D. - provided funds to the MIT contract  | Garnett Bailey   | Henson, ADPO-48C    |
| 18 December 95                   | R-2 Input for ONR (MAST)   | Bill Bunker      | Caposell, ADPO-48   |
| 21 December 95                   | P.I.D. - added funds to the AT&T contract and modified a paragraph in the Statement of Work            | Garnett Bailey   | Henson, ADPO-48C    |
| 29 December 95                   | Report on Power and S-Parameter Measurements on Raytheon PHEMT Power Amplifiers                        | Maurice Daniel   | Anderson, 6855      |
| <b>1 JANUARY - 31 MARCH 1996</b> |  |                  |                     |
| 08 January 96                    | P.I.D. - exercises Options 1B/Option 1C to Loral   | Garnett Bailey   | Henson, ADPO-48C    |
| 10 January 96                    | TRP Comparisons/Recommendations  | Ron Wade         | Caposell, ADPO-48   |
| 23 January 96                    | Recommendations on TI MAFET contract   | Ron Wade         | Marshall, ADPO-48D  |
| 24 January 96                    | HDMP Analysis  | Ron Wade         | Fenton, AIR-4.5T    |
| 25 January 96                    | State-of-the-art PAEs  | Ron Wade         | Webb, 6850          |
| 14 February 96                   | Wire Bonding Procedures and Techniques   | Maurice Daniel   | Anderson, 6855      |

| <u>Date Delivered</u>         | <u>Title/Topic</u>   | <u>Author(s)</u> | <u>Recipient(s)</u>        |
|-------------------------------|--|------------------|----------------------------|
| 16 February 96                | Report on MAFET Bidder's Brief   | Ron Wade         | Borsuk, 6800<br>Webb, 6850 |
| 23 February 96                | P.I.D. - provides funds to Options 1A/1D for Loral                                   | Garnett Bailey   | Henson, ADPO-48C           |
| 26 February 96                | Wire Bonding Procedures and Techniques Update  | Maurice Daniel   | Anderson, 6855             |
| 01 March 96                   | List of MAFET Transitions  | Ron Wade         | Caposell, ADPO-48          |
| 07 March 96                   | P.I.D. - adds FY96 funds to ETEC   | Garnett Bailey   | Henson, ADPO-48C           |
| 07 March 96                   | P.I.D. - cancels the basic P.I.D. (N00019-95-P7-023) for Loral                       | Garnett Bailey   | Henson, ADPO-48C           |
| 07 March 96                   | P.I.D. - adds \$40K for Task 2 for AT&T  | Garnett Bailey   | Henson, ADPO-48C           |
| 07 March 96                   | P.I.D. - cancels the basic P.I.D. (N00019-95-P7-023) for Loral                       | Garnett Bailey   | Henson, ADPO-48C           |
| 22 March 96                   | IR Imaging of Raytheon TS-0020 Power Amplifiers Before and After Life Testing Report | Maurice Daniel   | Anderson, 6855             |
| 25 March 96                   | P.I.D. - provides FY96 funds for MIT   | Garnett Bailey   | Henson, ADPO-48C           |
| 25 March 96                   | P.I.D. - provides incremental funding for Loral                                      | Garnett Bailey   | Henson, ADPO-48C           |
| <b>1 APRIL - 30 JUNE 1996</b> |  |                  |                            |
| 1 Apr - 30 June 96            | Briefing changes   | Bill Bunker      | Caposell, AIR-4.5T         |
| 1 Apr - 30 June 96            | Versions of execution plan   | Bill Bunker      | Caposell, AIR-4.5T         |
| 03 April 96                   | P.I.D. - SBIR Phase II effort for Lightning Optical Corporation                      | Garnett Bailey   | Cudd, AIR-4.5T4            |
| 09 April 96                   | P.I.D. - Transfer of Government property - AT&T                                      | Garnett Bailey   | Henson, ADPO-48C           |
| 12 April 96                   | P.I.D. - Extension of contract by 4 months for Lockheed Sanders                      | Garnett Bailey   | Henson, ADPO-48C           |
| 24 April 96                   | Revised SOW - Compact Software   | Ron Wade         | Henson, ADPO-48C           |
| 25 April 96                   | Cost of S.S. Power Modules   | Ron Wade         | Abrams, 6844               |
| 25 April 96                   | Viewgraphs for Advanced RF Sensor Technology   | Ron Wade         | Webb, 6850                 |
| 30 April                      | Viewgraphs and data  | Ron Webb         | Webb, 6850                 |
| 30 April 96                   | Memo on Call for 6.3 Mid-year Progress Reports                                       | Bill Bunker      | Caposell, AIR-4.5T         |
| 30 April 96                   | MAST program review agenda   | Bill Bunker      | Caposell, AIR-4.5T         |

| <u>Date Delivered</u>             | <u>Title/Topic</u>   | <u>Author(s)</u> | <u>Recipient(s)</u> |
|-----------------------------------|--|------------------|---------------------|
| 06 May 96                         | Instructions to briefers   | Bill Bunker      | Caposell, AIR-4.5T  |
| 06 May 96                         | MAFET Accomplishment - TI  | Ron Wade         | Dietrich, 6856      |
| 06 May 96                         | MAFET Accomplishment - Hittite   | Ron Wade         | Dietrich, 6856      |
| 07 May 96                         | MAFET Accomplishment - Lockheed Martin   | Ron Wade         | Marshall, ADPO-48D  |
| 20 May 96                         | Program review announcement  | Bill Bunker      | Caposell, AIR-4.5T  |
| 23 May 96                         | P.I.D. - Providing incremental funding for SVGL Systems, Inc.                                      | Garnett Bailey   | Henson, ADPO-48C    |
| 23 May 96                         | P.I.D. - Providing incremental funding for Loral   | Garnett Bailey   | Henson, ADPO-48C    |
| 23 May 96                         | P.I.D. - Providing incremental funding for Loral   | Garnett Bailey   | Henson, ADPO-48C    |
| 24 May 96                         | MIMIC Microchip Photographic Inventory - Ver. 1  | Maurice Daniel   | Anderson, 6855      |
| 07 June 96                        | Program review pamphlet  | Bill Bunker      | Caposell, AIR-4.5T  |
| 12 June 96                        | Final list of attendees  | Bill Bunker      | Caposell, AIR-4.5T  |
| 13 June 96                        | Letter with Bias Display Box Schematic attachment  | Maurice Daniel   | Anderson, 6855      |
| 19 June 96                        | Electronic Stub Book   | Bruce Walpole    | Parker, 6840        |
| 30 June 96                        | MP3WG meeting minutes  | Bruce Walpole    | Parker, 6840        |
| 30 June 96                        | SOW for sub-contract with SAIC   | Bruce Walpole    | Parker, 6840        |
| 30 June 96                        | Production of draft of S&T for MPM and Computational Techniques                                    | Bruce Walpole    | Abrams, 6844        |
| <b>1 JULY - 30 SEPTEMBER 1996</b> |  |                  |                     |
| 07 July 96                        | MAST Multi-year Execution Plan   | Bill Bunker      | Caposell, AIR-4.5T  |
| 17 July 96                        | PID - Providing FY96 funds for Option 1A/1D for Loral  | Garnett Bailey   | Henson, ADPO-48C    |
| 05 August 96                      | MMACE Phase 3 Working Meeting Minutes  | Bruce Walpole    | Abrams, 6844        |
| 06 August 96                      | Letter providing mechanical drawing of HEMT fixture as well as machine shop tool requirements list | Maurice Daniel   | Anderson, 6855      |
| 08 August 96                      | MAFET Accomplishment - Lockheed Martin   | Ron Wade         | Marshall, ADPO-48D  |
| 09 August 96                      | MAFET Accomplishment - EMS Technologies, Inc.  | Ron Wade         | H. Newman, NRL      |
| 14 August 96                      | PID - Redirecting funds for ETEC   | Garnett Bailey   | Henson, ADPO-48C    |
| 15 August 96                      | Estimated Analog/Microwave Semiconductor Market Viewgraph and Information                          | Ron Wade         | Parker, 6840        |

| <u>Date Delivered</u>               | <u>Title/Topic</u>   | <u>Author(s)</u> | <u>Recipient(s)</u>                    |
|-------------------------------------|--|------------------|--|
| 20 August 96                        | MAFET Accomplishment - Hittite Microwave Corp.   | Ron Wade         | Marshall, ADPO-48D                     |
| 02 September 96                     | PID - Adding FY96 funds to Loral   | Garnett Bailey   | Henson, ADPO-48C                       |
| 05 September 96                     | MAFET Directory  | Ron Wade         | All NAVAIR & NRL customers             |
| 14 September 96                     | Directions for the Next Generation of MMIC Devices and Systems Symposium Report        | Ron Wade         | Caposell, ADPO-48<br>All NRL Customers |
| 23 September 96                     | MAST Program Summary   | Bill Bunker      | Caposell, AIR-4.5T                     |
| <b>1 OCTOBER - 20 NOVEMBER 1996</b> |  |                  |  |
| 09 October 96                       | P.I.D. - canceling basic P.I.D. for ETEC Systems, Inc.                                 | Garnett Bailey   | Henson, ADPO-48C                       |
| 16 October 96                       | CCR  | Bruce Walpole    | Abrams, 6844                           |
| 16 October 96                       | Navy Exploratory Development Program in Vacuum Electronics Document                    | Bruce Walpole    | Parker, 6840                           |
| 22 October 96                       | IR Imaging of Raytheon PHEMT Two-Stage Amplifiers Before and After Life Testing Report | Maurice Daniel   | Anderson, 6855                         |

**APPENDIX C**

A. Funding Status

|    |  |                           |
|----|--|---------------------------|
| 1. | <u>Contract Ceilings</u>                 | <u>Cumulative Ceiling</u> |
|    | Base Year Ceiling = \$1,323,689          | \$1,323,689               |
|    | First Option Year Ceiling = \$1,374,912  | \$2,698,601               |
|    | Second Option Year Ceiling = \$1,290,713 | \$3,989,314               |
|    | Third Option Year Ceiling = \$1,483,665  | \$5,472,979               |

2. Funds Received

| <u>Mod #</u> | <u>Date Signed</u> | <u>Amount</u>    | <u>Running Total</u> |
|--------------|--------------------|------------------|----------------------|
| 0            | 09/30/92           | \$ 100,000       | 100,000              |
| 1            | 12/21/92           | \$ 225,000       | 325,000              |
| 2            | 01/29/93           | Admin.<br>change | 325,000              |
| 3            | 02/16/93           | \$ 150,000       | 475,000              |
| 4            | 04/23/93           | \$ 150,000       | 625,000              |
| 4            | 04/23/93           | \$ 227,000       | 852,000              |
| 5            | 05/18/93           | \$ 15,000        | 867,000              |
| 6            | 07/21/93           | Admin.<br>change | 867,000              |
| 7            | 07/21/93           | \$ 25,000        | 892,000              |
| 8            | 07/07/93           | \$ 25,000        | 917,000              |
| 9            | 08/31/93           | \$ 150,000       | 1,067,000            |
| 9            | 08/31/93           | \$ 150,000       | 1,217,000            |
| 10           | 09/08/93           | \$ 150,000       | 1,367,000            |
| 11           | 09/16/93           | \$ 25,000        | 1,392,000            |
| 12           | 09/17/93           | \$ 30,000        | 1,422,000 *          |
| 13           | 12/22/93           | \$ 50,000        | 1,472,000 *          |
| 14           | 03/01/94           | \$ 100,000       | 1,572,000            |
| 15           | 03/21/94           | \$ 50,000        | 1,622,000            |
| 16           | 03/31/94           | \$ 150,000       | 1,772,000            |
| 16           | 03/31/94           | \$ 70,000        | 1,842,000            |
| 16           | 03/31/94           | \$ 60,000        | 1,902,000 *          |
| 17           | 04/30/94           | \$ 45,000        | 1,947,000            |
| 18           | 05/18/94           | \$ 174,000       | 2,121,000            |
| 19           | 06/02/94           | \$ 50,000        | 2,171,000            |
| 20           | 06/10/94           | \$ 15,000        | 2,186,000            |
| 21           | 06/21/94           | \$ 125,000       | 2,311,000            |
| 22           | 06/28/94           | \$ 18,000        | 2,329,000            |
| 23           | 07/05/94           | \$ 200,000       | 2,529,000            |
| 24           | 09/15/94           | \$ 125,000       | 2,654,000            |
| 24,25        | 09/30/94           | \$ 48,290        | 2,702,290 *          |
| 26           | 01/10/95           | \$ 150,000       | 2,852,290 *          |
| 27           | 03/06/95           | \$ 160,000       | 3,012,290            |
| 28           | 03/14/95           | \$ 11,400        | 3,023,690 *          |
| 29           | 04/10/95           | \$ 335,300       | 3,358,990            |
| 30,31        | 04/24/95           | \$ 48,600        | 3,407,590 *          |

| <u>Mod #</u> | <u>Date Signed</u> | <u>Amount</u>    | <u>Running Total</u> |    |
|--------------|--------------------|------------------|----------------------|----|
| 32           | 07/06/95           | \$ 44,090        | 3,451,680            |    |
| 33           | 07/17/95           | \$ 200,000       | 3,651,680            |    |
| 34           | 08/02/95           | \$ 300,000       | 3,951,680            |    |
| 35           | 09/05/95           | \$ 30,000        | 3,981,680            | *  |
| 36           | 10/18/95           | Admin.<br>change | 3,981,680            |    |
| 37           | 11/02/95           | Admin.<br>change | 3,981,680            |    |
| 38           | 12/07/95           | \$ 100,000       | 4,081,680            | *  |
| 39           | 12/28/95           | \$ 110,000       | 4,191,680            | *  |
| 40           | 02/07/96           | \$ 100,000       | 4,291,680            | *  |
| 41           | 03/06/96           | \$ 66,000        | 4,357,680            | *  |
| 42           | 03/21/96           | \$ 125,000       | 4,482,680            |    |
| 43           | 05/03/96           | \$ 95,000        | 4,577,680            | *  |
| 43           | 05/03/96           | \$ 200,000       | 4,777,680            | *  |
| 43           | 05/03/96           | \$ 23,670        | 4,801,350            |    |
| 44           | 05/21/96           | \$ 29,330        | 4,830,680            |    |
| 45           | 05/23/96           | \$ 162,000       | 4,992,680            | *  |
| 46           | 06/26/96           | \$ 70,000        | 5,062,680            | *  |
| 47           | 07/02/96           | \$ 15,000        | 5,077,680            |    |
| 48           | 07/08/96           | \$ 200,000       | 5,277,680            |    |
| 48           | 07/08/96           | \$ 100,000       | 5,377,680            | *  |
| 49           | 08/19/96           | \$ 95,299        | 5,472,979            | ** |

\* Plateaus on funding chart

\*\* Adjusted Ceiling - \$5,472,979

Original Ceiling - \$5,610,452

Delta - \$ 137,473



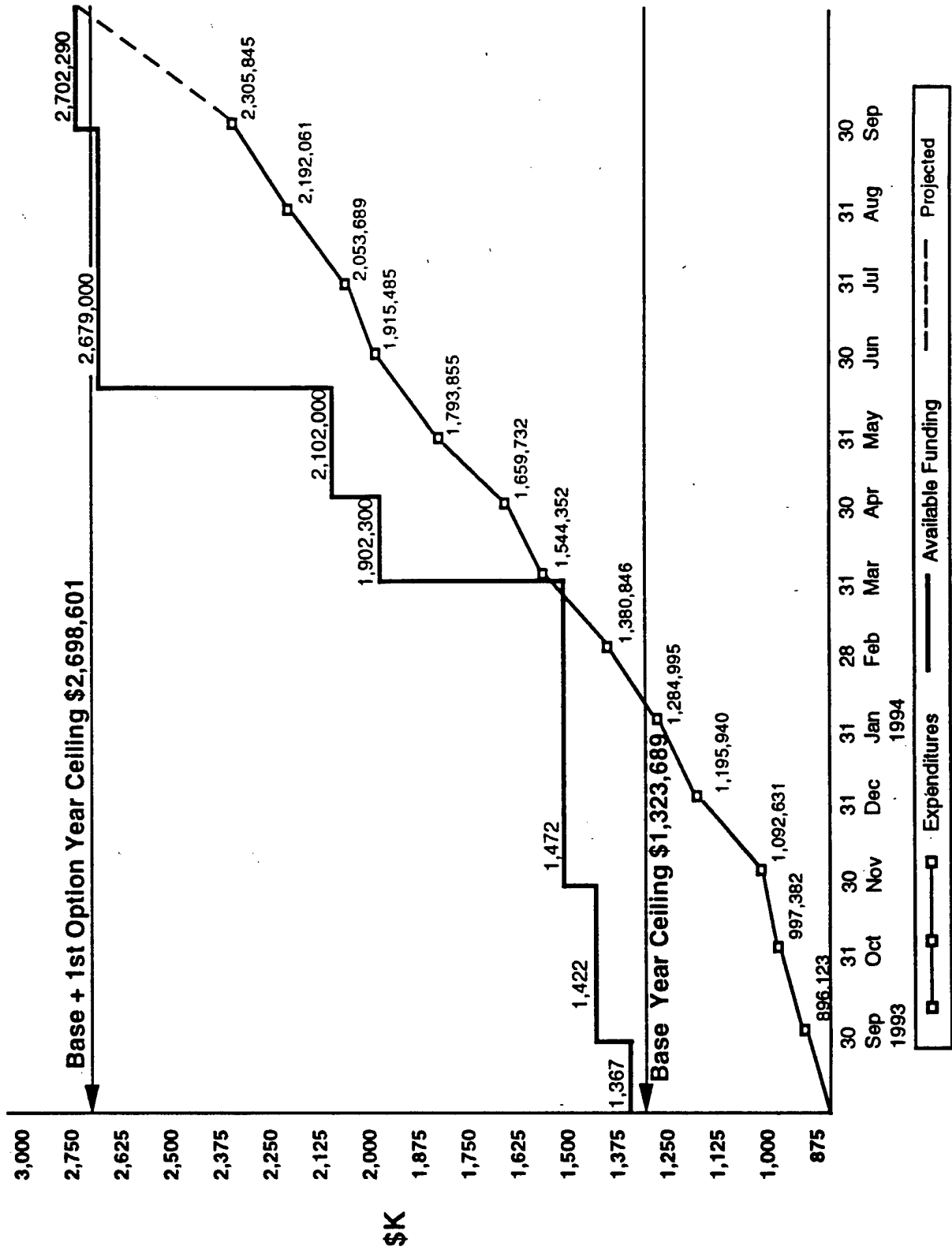

Monthly Contract Expenditures

\$K



