

APPLYING PROBABILISTIC RISK ASSESSMENT AND
DECISION ANALYSIS TECHNIQUES TO AVOID EXCESSIVE
REMEDIAL INVESTIGATION COSTS

THESIS

Alejandro Hinojos, 1st Lieutenant, USAF

AFIT/GEE/ENS/96D-02

19970205 012

DTIC QUALITY INSPECTED 3

DISTRIBUTION STATEMENT A

Approved for public release;
Distribution Unlimited

The views expressed in this thesis are those of the author and do not reflect the official policy or position of the Department of Defense or the U.S. Government

AFIT/GEE/ENS/96D-02

APPLYING PROBABILISTIC RISK ASSESSMENT AND
DECISION ANALYSIS TECHNIQUES TO AVOID EXCESSIVE
REMEDIAL INVESTIGATION COSTS

THESIS

Presented to the Faculty of the School of Engineering
of the Air Force Institute of Technology

Air University

In Partial Fulfillment of the Requirements for the Degree of
Master of Science in Engineering and Environmental Management

Alejandro Hinojos, B.S.

1st Lieutenant, USAF

December 1996

Approved for public release; distribution unlimited



THESIS APPROVAL

Student: Alejandro Hinojos, 1st Lieutenant, USAF

Class: GEE-96D

Title: Applying Probabilistic Risk Assessment and Decision Analysis Techniques to
Avoid Excessive Remedial Investigation Costs

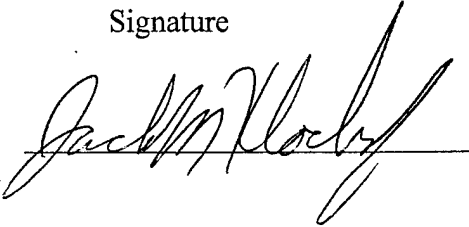
Defense Date: 22 November 1996

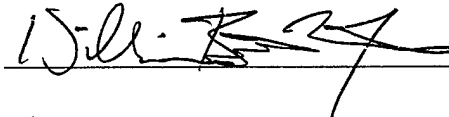
Committee:	Name/Title/Department	Signature
Advisor	Jack M. Kloeber Jr., LTC, USA Assistant Professor Department of Operational Sciences	
Reader	Michael L. Shelley, Lt Col, USAF Associate Professor Department of Engineering and Environmental Management	
Reader	William B. Nixon, Major, USAF Assistant Professor Department of Engineering and Environmental Management	

Preface

This research was accomplished because, in the author's view, too much money is being spent on environmental investigation. Additional studies are often requested with little if any cost analysis or objective justification. With the magnitude of environmental problems on the horizon and limited resources, less environmental resources need to be applied to investigation and more need to be applied to remediating the risk. This research is done in an effort to aid analysts and decision makers in evaluating the cost trade-off between gathering additional information to reduce the uncertainty and making the decision without additional information.

Certain individuals deserve recognition for their contributions to the completion of this research. Major Andrew Maccabe and Captain Brian Sassaman, at the Environmental Sciences Branch, sponsored my research by providing direction on the needs of the Air Force in this area and offered assistance and feedback when and where necessary. They were also instrumental in helping me attend an Air Force sponsored probabilistic risk assessment training workshop that was critical to this research. At the 88 ABW/EM shop, Tim Clendennon and Mary Seitz were instrumental in gathering the information necessary to accomplish the analysis. The members of the Aeronautical Systems Center/EM Restoration Division were all very helpful and willing to help gather the information to analyze Site 4. Special thanks goes to Bill Brown, Scott Dennis, and Sandra Elberts who especially went out of their way to help me apply the methodology developed in this research. The technical and professional guidance that I received from my thesis advisor, LTC Jack Kloeber, was invaluable to the final product. The comments from my readers,

Lt Col Shelley and Maj Brent Nixon, added to the clarity and organization of the research.

To all these people, I send my gratitude.

My deepest gratitude, though, goes to my wife Cari and my boys Cameron, Alejandro, and Jacob who have been so patient in waiting for dad to return from the cellars of AFIT life. I want to thank my wife who has unselfishly carried the brunt of the load in our household for the last 18 months. It hasn't been easy for either one of us, but I thank her for her willingness to give. To my boys I also owe a gesture of gratitude for all they sacrificed. I only hope that I can make up all those nights and weekend afternoons when they were ready to play and I was unable to oblige.

Alejandro Hinojos

TABLE OF CONTENTS

	Page
Preface	ii
List of Figures	vi
List of Tables.....	ix
List of Acronyms	xi
Abstract.....	xii
1. Introduction.....	1
1.1 Background	1
1.2 Dealing with the Complexity and Liabilities	3
1.3 The Need for Evolution	9
1.4 Current Model	11
1.5 Research Objective	11
1.6 Thesis Contents	12
2. Literature Review	13
2.1 Introduction.....	13
2.2 Historical Review of Risk Assessment.....	13
2.2.1 Initial Guidelines to Risk Assessment.....	13
2.2.2 EPA's Response to NRC Recommendations.....	15
2.2.3 Relative Risk.....	15
2.3 EPA's Deterministic Risk Assessment Structure.....	18
2.3.1 Hazard Identification	19
2.3.2 Dose Response Assessment.....	19
2.3.3 Exposure Assessment.....	22
2.3.4 Risk Characterization	29
2.4 Monte Carlo Method	31
2.5 Drawbacks to Probabilistic Risk Assessment	31
2.6 How the Initial Model Handled the Task	33
2.6.1 RI/FS Decision Strategy.....	34
2.6.2 Characterizing the Risk Distribution	35
2.6.3 Decision Analysis Tools	39
3. Methodology	41
3.1 Introduction.....	41
3.2 Deterministic Risk Estimate	41
3.3 The Monte Carlo Approach	42

3.3.1	Variability	43
3.3.2	Uncertainty	44
3.3.3	The Importance of Both Variability and Uncertainty	45
3.3.4	Monte Carlo Simulation Method	46
3.4	Decision Analysis	47
3.5	Deterministic Sensitivity Analysis	48
3.6	Non-site Specific Distributions	50
3.7	Initial Probabilistic Risk Assessment Input Distributions	53
3.7.1	Tapwater Ingestion	54
3.7.2	Exposure Duration	54
3.7.3	Oral Slope Factor	56
3.7.4	Exposure Frequency	57
3.7.5	Mean Concentration	58
3.7.6	Body Weight	62
3.7.7	Exposure Time	63
3.7.8	Surface Area to Body Weight Ratio	63
3.7.9	Inhalation Rate	64
3.8	Initial Probabilistic Risk Assessment	65
3.9	Initial Probabilistic Sensitivity Analysis	69
3.9.1	Probabilistic Sensitivity Analysis on Strength of Effects	69
3.9.2	Probabilistic Sensitivity Analysis on Shape of Distribution	71
3.10	Consideration for Further Field Investigation	73
3.10.1	Exposure Duration	74
3.10.2	Oral Slope Factor	74
3.10.3	Tapwater Ingestion	76
3.10.4	Mean Concentration	77
3.10.5	Exposure Frequency	78
3.11	Final RI70% Risk Distribution	78
3.12	The Need for Uncertainty Analysis of the Risk Distribution	79
3.12.1	Probabilistic Uncertainty Analysis	80
3.12.2	Reducing the Uncertainty with Additional Samples	81
3.13	Benefits of Methodology	85
4.	Findings and Analysis	86
4.1	Introduction	86
4.2	Future Commercial Worker, OU2, WPAFB	86
4.2.1	Benzene Mean Concentration Distributions	86
4.2.2	Probabilistic Risk Simulation Results for OU2	89
4.2.3	Decision Analysis for OU2	95
4.3	Commercial Worker, Site 4, AFP44	100
4.3.1	Site 4 Input Distributions	101
4.3.2	Probabilistic Risk Simulation Results for Site 4	112
4.3.3	Decision Analysis Results for Site 4	116
4.4	Marginal Returns of Reducing the Uncertainty	118

V. Conclusions and Recommendations.....	121
5.1 Conclusions	121
5.2 Recommendations.....	130
Appendix A: Calculations for Mean Concentration After RI70%.....	132
Appendix B: Concentrations Distributions for Analysis in Chapter 4	134
Appendix C: Determining the Relative Importance of Accurately Estimating the Uncertainty in the Mean Concentration	143
Appendix D: Input Values for RI70% Decision Support Model for OU2	149
Appendix E: Input Values for RI100% Decision Support Model for OU2	153
Appendix F: Input Values for RI70% Decision Support Model for Site 4	156
Appendix G: Input Values for RI100% Decision Support Model for Site 4	159
Bibliography	162
Vita	167

List of Figures

Figure 1-1: Three Hypothetical Exposure Factor Distributions.....	5
Figure 1-2: RI/FS Decision Tree	8
Figure 2-1: Strategy Generation Table for the PA Decision.....	34
Figure 2-2: Risk Probability Distribution Graph	38
Figure 3-1: Tornado Diagram of RME Point Estimate of Risk after RI70%	51
Figure 3-2: Crystal Ball Empirical Frequency Distribution for Tapwater Ingestion	54
Figure 3-3: Crystal Ball Empirical Frequency Distribution for Exposure Duration	56
Figure 3-4: Estimated Distribution for Benzene Carcinogenic Slope Factor.....	57
Figure 3-5: Best Fit Gamma Distribution for Benzene in Groundwater.....	60
Figure 3-6: Best Fit Simulated Mean Concentration Distribution vs Normal Distribution	61
Figure 3-7: Distribution of Weight for Men Older than 18 Years of Age	63
Figure 3-8: Crystal Ball Empirical Frequency Distribution for Exposure Time.....	63
Figure 3-9: Surface Area to Body Weight Ratio for Men Older than 18 Years of Age	64
Figure 3-10: Crystal Ball Empirical Frequency Distribution for Inhalation Rate for Men Between the Ages of 18 and 30.....	64
Figure 3-11: Results of Simulation of Clarimont's Initial Model	66
Figure 3-12: Results of Initial RI70% Risk Simulation	67
Figure 3-13: Probabilistic Sensitivity Analysis Results for Initial RI70%.....	70
Figure 3-14: Results of Probabilistic Sensitivity Analysis on Shape of Risk Distribution for exposure	72
Figure 3-15: Final Estimate of Uncertainty in Human Toxicity Value of	

Benzene Based on Animal Data	76
Figure 3-16: Final Results of PRA for OU2 with 14 Samples from RI70%	80
Figure 3-17: Percent Contribution for Each Variable in the Site Investigation PRA	82
Figure 3-18: Simulated Reduction in the Uncertainty in the Mean Concentration Distribution with Additional Samples	84
Figure 4-1: The Reduction in the Uncertainty of the Mean Concentration Distribution.....	88
Figure 4-2: A Comparison of the PMRI100% and MRI100%	88
Figure 4-3: Results of Initial RI70% Risk Distribution for OU2	90
Figure 4-4: Results of PRA for OU2 with 20 samples from RI100%	92
Figure 4-5: Recommendation for OU2 after the RI70%	96
Figure 4-6: Recommendation for OU2 after the RI100%	97
Figure 4-7: Distribution of the Surface Area of Arms for Men.....	105
Figure 4-8: Distribution of the Surface Area of Hands for Men	106
Figure 4-9: Distribution of Uncertainty in PM10	107
Figure 4-10: Distribution of Activity Level Multiplier for Commercial Worker..	109
Figure 4-11: Distribution of VQ for Adults	109
Figure 4-12: Results of the PRA from Site 4 with 45 samples from RI70%	113
Figure 4-13: Results of the PRA from Site 4 with 65 samples from RI100%	114
Figure 4-14: Recommendation for Site 4 after the RI70%	117
Figure 4-15: Recommendation for Site 4 after RI100%.....	117
Figure 5-1: Information Typically Provided from Deterministic Point Estimate Approach	127
Figure 5-2: General Probabilistic Density Function for a Range of Risks	128

List of Tables

Table 3-1: Deterministic RME Risk Calculations	43
Table 3-2: Initial Estimate of Range of Input Variables	50
Table 3-3: Selected Distribution Percentiles of Residential Occupancy Period for All Houses	56
Table 3-4: Selected Percentiles From Initial RI70% Risk Distribution	68
Table 3-5: Key Statistics from Initial RI70% Risk Distribution.....	68
Table 3-6: Key Statistics from PRA Simulation after RI70%	79
Table 4-1: Concentration Distributions used for OU2	87
Table 4-2: Selected Percentiles from PRA Simulations for OU2	93
Table 4-3: Key Statistics from PRA Simulations for OU2	93
Table 4-4: RME Risk Calculations for Commercial Worker at Site 4	102
Table 4-5: Distributions used for Risk Simulation at Site 4.....	104
Table 4-6: Selected Percentiles from PRA Simulations for Site 4	115
Table 4-7: Key Statistics from PRA Simulations for Site 4	115
Table 4-8: Spearman Rank Correlation Coefficients for PRA Simulations	119

List of Acronyms

A -- Activity Level Multiplier
ABS -- Absorption Factor
AC -- Air Concentration
AF -- Adherence Factor
AFP44 -- Air Force Plant 44
AT -- Averaging Time
BMR -- Basal metabolic rate
BW -- Body Weight
C -- Chemical Concentration
CA -- Clearly Acceptable Risk
Cd -- Cadmium
Cd-MC -- mean concentration of cadmium
CDF -- Continuous Density Function
CDI -- Chronic Daily Intake
CERCLA -- Comprehensive Environmental Response, Compensation, and Liabilities Act
CF -- Conversion Coefficient
CLT -- Central Limit Theorem
CPF -- Cancer Potency Factor
Cr -- Chromium
Cr-MC - mean concentration of chromium
CR -- Contact Rate
CW -- Chemical Concentration in Water
CUA -- Clearly Unacceptable Risk
DPL -- ADA Decision Systems, 1995, Decision Analysis Software
DRfD -- Dermal Reference Dose
E -- Energy Expenditure Rate
EF -- Exposure Frequency
EFD -- Exposure Frequency and Duration
EPA -- United States Environmental Protection Agency
ET -- Exposure Time
H -- volume of oxygen consumed in production of 1 kJ of energy expended
Ing_R -- Ingestion Rate
Inh_R -- Inhalation Rate
IM -- Initial Model
IRfD -- Inhalation Reference Dose
IRIS -- Integrated Risk Information System
LOAEL -- Lowest-observable-adverse-effect level
MDL -- Minimum Detection Limit
NAS -- National Academy of Science
NCP -- National Contingency Plan
NFA -- No Further Action
NOAEL -- No-Observable-Adverse-Effect Level
NPL -- National Priorities List
NRC -- National Research Council

OU2 -- Operable Unit 2
PA -- Preliminary Assessment
PC -- Permeability Constant
PM10 -- Particulate matter with an aerodynamic diameter of less than or equal to 10 μm
POL -- Petroleum, Oil, and Lubricants
PRA -- Probabilistic Risk Assessment
RA -- Risk Assessment
RCRA -- Resource Conservation and Recovery Act
RfD -- Reference Dose
RME -- Reasonable Maximum Exposure
RI60% -- Remedial Investigation 60%
RI/FS -- Remedial Investigation and Feasibility Study
RPM -- Remedial Project Manager
SA -- Surface Area
SAB -- EPA's Science Advisory Board
SARA -- Superfund Amendments and Reauthorization Act
Sb -- Antimony
Sb-MC -- Mean concentration of Antimony
SF -- Slope Factor
SI -- Site Investigation
UBCL -- Upperbound Confidence Limit
UF_{AH} -- Uncertainty factor for extrapolating from animals to humans
UF_{HV} -- Uncertainty factor for extrapolating from average to sensitive humans
UF_S -- Uncertainty factor for extrapolating from subchronic to chronic
UF_L -- Uncertainty factor for extrapolating from a LOAEL to a NOAEL
UF_D -- Uncertainty factor when there is limited data for a chemical
MF -- modifying factor for any other particular uncertainties that may apply
VOI -- Value of Information
VQ -- ventilatory equivalent, ratio of the minute volume to oxygen uptake rate

Abstract

The majority of remediation resources have been consumed by costly and lengthy remedial investigation studies to characterize the human health risk (Lawrence, 1993:2963).

Unable to deal directly with the uncertainty resulting from the convolution of the uncertainties in a multitude of variables, and heavily persuaded by the liabilities, decision makers and regulators have relied on conservative assumptions and more studies to take appropriate actions (Graham *et al.*, 1992:411). The main objective of this research is to provide tools and techniques to aid risk analysts in determining whether it would be beneficial to gather additional information or whether the decision to take an appropriate action can be made without further investigation. This research provides some probabilistic risk assessment and decision analysis techniques to avoid using simple conservative assumptions to deal with the complex uncertainties to evaluate the value of information of additional studies in the complex remediation decision process. The methodologies in this research were tested on Operable Unit 2, Wright-Patterson AFB, Ohio, and Site 4, Air Force Plant 44, Arizona.

APPLYING PROBABILISTIC RISK ASSESSMENT AND DECISION ANALYSIS TECHNIQUES TO AVOID EXCESSIVE REMEDIAL INVESTIGATION COSTS

1 Introduction

1.1 Background

In the wake of the 1970's environmental movement, Congress passed the Comprehensive Environmental Response, Compensation, and Liabilities Act (CERCLA) in December of 1980. Congress wanted to achieve two goals with the legislation: clean-up of abandoned or uncontrolled hazardous waste sites and assurance that responsible parties would bear the cost of clean-up. Knowing that responsible parties would not be found for all sites, Congress authorized a "Superfund" budget of \$1.6 billion for the next five years to begin the remediation of disposal. The Environmental Protection Agency (EPA) was instructed to develop a National Priorities List (NPL) of at least 400 of the nation's worst sites that would be eligible for Superfund funding (Dienemann, 1992:166).

When CERCLA was up for reauthorization in 1985, it was obvious that the hazardous waste disposal problem had been severely underestimated. The EPA had 538 sites on the NPL and estimated the final number would reach 2000. At the end of 1984, the EPA predicted that only 10 of the 538 sites on the NPL would be remediated to an acceptable human health risk level or closed-out by 1985. In disappointment with the progress, Congress reauthorized CERCLA as the Superfund Amendments and Reauthorization Act (SARA) of 1986 with mandates for EPA to clean up more sites. Congress also increased the authorized funding from the original \$1.6 billion to \$8.5 billion (Dienemann, 1992:166).

By late 1994 the National Priorities List had grown to approximately 1200 sites (Bredehoeft, 1994:98). A disappointing statistic is that it takes an average of 10 years to clean up one NPL site. Of these ten years only three are used for on-site remediation construction and actual clean-up. The first seven years are spent on prolonged studies to characterize the potential human health risk. These prolonged studies resulted from a pattern that has been called the "study to death" syndrome, which has been spurred on by both attorneys, who fear lawsuit for improper characterization of the site or ineffective remediation programs, and regulatory agencies, who would rather ask for another study than commit to an appropriate solution (Duplancic, 1989:69). As of 1993, the average cost was estimated at \$25 million per site, of which the majority is spent on characterizing the site as opposed to clean-up (Ember, 1993:19).

The extent of the environmental clean-up program described thus far only includes those sites which were constructed prior to 1984 and considered a national priority under CERCLA. The problem gets much larger when other sites are considered that are not a national priority, but pose some human health risks that require clean-up. Additionally, there are thousands of sites that were constructed after 1984 that do not fall under the jurisdiction of CERCLA. Clean-up at these sites is governed by the Corrective Actions Program under the Resource Conservation and Recovery Act (RCRA) of 1986. There are some who believe that the clean-up of RCRA sites will approach the scope and magnitude of the Superfund program (Lowrance, 1991:47). The magnitude of the current problem and the anticipated growth indicate a more streamlined method of site characterization is needed to move more rapidly to the clean-up phase of remediation.

1.2 Dealing with Complexity and Liability

Two causes of the high cost and extended duration of site characterization have been the liabilities involved with policy and remediation decisions and the complexity of the process. The first reason is a result of how uncertainty has been handled to deal with the liabilities of improperly characterizing risk at a site (Duplancic, 1993:50). In this research it is assumed that the reader comprehends the liabilities, for both the site owner and regulating program manager, of improperly characterizing a hazardous waste site. To discuss the first cause it is important to briefly address the concept of reasonable maximum exposure (RME).

The methodology in the Superfund risk assessment guidelines for estimating risks have been criticized for using conservative assumptions to deal with the uncertainties in estimated variables that result in risks that are significantly greater than the actual risk present (Cullen 1994; Ember, 1993:19). EPA guidelines point out that remediation decisions should be based on a reasonable maximum exposure (RME) expected to occur presently or in future uses of the land (USEPA, 1989c:Ch 6, 4). The RME is defined as the highest exposure that is reasonably expected to occur (USEPA, 1989c:Ch 6, 5). The definition of the RME is not further clarified in the guidelines and many of the definitions such as 'reasonable' and 'maximum' have been left to interpretations of remedial project managers (Duplancic, 1993:52). The RME is calculated with a series of exposure variables according to the equations outlined in the guidelines (USEPA, 1989c).

Most of the variables used to estimate the RME have some uncertainty associated with their estimated values. Uncertainty can mean many things, but in decision making, it

has generally implied the inability to estimate the value of the variable due to several issues outlined in Section 3.4. In risk assessment, uncertainty is divided into the categories of variability and uncertainty (McKone, 1994:450). Variability is the natural difference that exists between the members of the population of interest. Uncertainty, in contrast, is the imprecision associated with our estimate of the variable and its real variability (Finley *et al.*, 1994:534). To deal with this uncertainty and variability, the guidelines have recommended the use of high end percentiles for selected variables to ensure the variables are not underestimated. If sufficient data exist, the EPA's guidelines suggest that the estimated 95th percentile be used for numerous exposure factors in the RME calculations (USEPA, 1989c:Ch 6). Other percentiles are used for a limited number of factors. Using the point estimate risk calculations, these numbers would be combined in the appropriate risk equation to determine the RME point estimate of risk. What is the probability that any one individual would simultaneously possess all these extreme characteristics? Is it reasonable to assume that this type of maximum exposure is likely to occur? These questions can only be answered through further analysis.

Using a simple binomial trial to determine the probability that a sensitive individual in the population would possess all the qualities estimated at the 95th percentile can shed some light on the possible conservatism of the RME calculations. To keep the analysis simple, assume that only three exposure factors are being estimated at the 95th percentile in the risk calculations and that sufficient data has been gathered to confidently assume that the distributions of the factors are as shown in Figure 1-2. Regardless of the distribution, using the estimate of the 95th percentile there is approximately a 95% chance

that any randomly selected individual in the population would possess an exposure factor value greater than the 95th percentile and a 5% chance that the individual would possess an exposure factor value less than the 95th percentile.

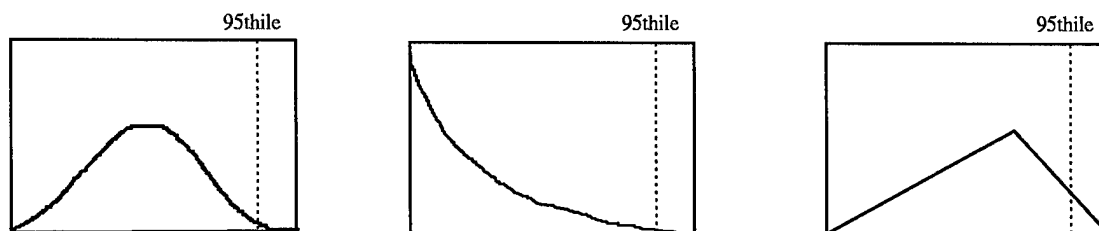

Figure 1-1: Three Hypothetical Exposure Factor Distributions.

Assuming the exposure factors are independent, a binomial trial can be used to estimate the probability that any given person would possess any number of the qualities above the 95th percentile. Each exposure factor is considered a trial with a probability of success equal to 0.05. The probability that any one individual would possess all three exposure qualities above the 95th percentile is $(.05)^3 = 0.000125$. In other words, only 0.0125% of the population would possess all three characteristics above the 95th percentile and experience a risk equal to or greater than the RME risk. The assumption that only three exposure factors are estimated at the 95th percentile would probably be satisfied in a single exposure pathway. When exposure factors are combined across pathways, even more conservative estimates may result. Others have done more elaborate calculations that have resulted in similar conclusions (Cullen, 1994: 391; Hattis and Burmaster, 1994:715).

Is the 99.99th percentile a reasonable maximum exposure an individual might experience or does it estimate a maximum possible exposure? Unable to deal directly with uncertainty and heavily persuaded by the consequences of making mistakes, decision

makers have had to rely on these conservative assumptions to ensure that estimated risks include individuals who might experience the quite conservatively estimated RME (Graham *et al.*, 1992:411). Many studies have been and are being conducted to show that many sites, characterized using the EPA's RME guidelines, have been characterized as posing significantly greater human health risk than the actual risk present (Finley and Paustenbach, 1994:70; Thompson *et al.*, 1992:59; Katsumata, 1994:115; Keenan, 1994:229). This conservative estimate of the risk has assured decision makers that the site has been conservatively characterized and has given them confidence to take appropriate actions. Unfortunately this confidence in making the decision and minimizing the liabilities has resulted in expenses that perhaps could have been avoided if the risk were more objectively estimated.

The EPA has made efforts to clarify the concept of the RME. The guidance that was sent out by F. Henry Habicht, Deputy Administrator, to the regional administrators in February of 1992 specifies that EPA risk assessments will provide descriptions of the individual risk that include the central tendency and high end portions of the risk distribution (USEPA, 1992b:21). Specifically, the guidance conceptually defines the high end risk as "the risks above the 90th percentile of the population distribution, but not higher than the individual in the population who has the highest risk" (USEPA, 1992b:24). Given that the population of interest is fairly homogeneous and that more sensitive populations cannot be further delineated, the guidance assumes that high end risk will be associated with the RME risk.

The second reason for the high costs and duration of the investigation phase has been the complexity of the remediation decision process. The planning and investigative portion of the remediation process for NPL sites, where the majority of the money and time has been spent, is called the Remedial Investigation and Feasibility Study (RI/FS) phase. The process is outlined in Title 40, Code of Federal Regulations Part 300, which is called the National Contingency Plan (NCP). This phase consists of a series of data gathering and analysis activities to determine the most appropriate remediation alternative.

The decisions made in the RI/FS phase must encompass a multitude of chemicals, exposure pathways, exposure factors, additive risks across pathways, costs, durations, liabilities, subsequent decisions, and many more variables simultaneously. Figure 1-1 shows a simplified decision tree that lays out the multitude of paths through the RI/FS that can be selected. The possible decision strategies are thoroughly discussed in Section 2.5.1. The squares indicate that a major decision must be made and the triangles indicate that the process terminates. The decision tree is condensed by the use of letter identifiers. For instance, if the decision is made at the preliminary assessment (Prelim Assmt) to take the 'removal action' (Removal) alternative, then the assessor moves to the decision block C of the 60% remedial investigation (RI60%) phase and continues there. If the decision tree were not condensed, it would be very complex because of the numerous paths that could be taken. This complexity makes it difficult to make cost effective decisions without the aid of analytical tools.

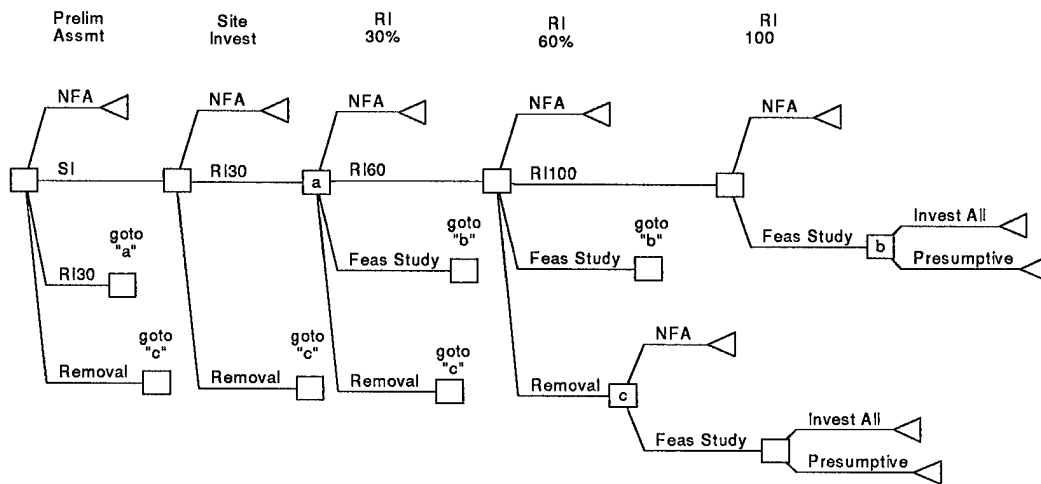

Figure 1-2: RI/FS Decision Tree

As discussed above, each variable used in assessing the risk has associated with it some variability and uncertainty. A significant portion of the RI resources is consumed trying to reduce the uncertainty in the estimated risk by obtaining additional information (Duplancic, 1993:51). Additional information serves to reduce the uncertainty in the parameters of interest. Variability, on the other hand, occurs naturally and cannot be reduced with more or better measurements (Finley *et al.*, 1994:534). As variables, along with their variability and uncertainty, are propagated through the risk calculations, determining the variability and uncertainty in the final point estimate becomes very complex. This complexity has caused decision makers and regulators to delay between taking action and to request additional information with hopes of reducing the uncertainty (Duplancic, 1993:52). Failing to recognize the difference between uncertainty and variability, some decision makers may have expended resources on additional studies to reduce the real variability in the risk or to marginally reduce the uncertainty without considering the value of information (VOI) (Hattis and Burmaster, 1994:716). The VOI is the added benefit of obtaining information that is not currently available. If VOI is not

considered in the RI/FS process, resources expended to further improve the characterization of the site could be incurred for a marginal reduction in the uncertainty.

In the remedial investigation it is difficult to calculate the VOI because of the magnitude and complexity of the problem. Environmental decision makers have not been afforded the tools necessary to deal with the complexities involved in making decisions. The slow development of computer software to efficiently manipulate the analysis (Burmester, 1989: 89) and the reluctance to adopt analytical tools used in other fields, such as observational methods and presumptive remedies, has hindered the evolution of the decision process (Duplancic, 1989:70). In order to deal with the current problems and anticipated problems, the decision process must be streamlined by developing tools for analysts and decision makers to manage this complexity.

1.3 The Need for Evolution

The concept of RME has been further clarified, but the decision maker is still left with the complexities and liabilities in estimating the RME that will properly estimate the high end risk. The assessor and regulator must determine what selected percentiles for values in the risk calculation will adequately estimate the RME risk. At which point, the subjective interpretations of 'reasonable,' 'maximum,' and 'adequately' blur the distinction between objective risk assessment and risk management.

The EPA has made considerable and commendable efforts to improve the remediation decision process, but the process must continue to evolve to properly deal with the complexities and liabilities without reliance on overly conservative assumptions. Recent publications, such as the 1992 Environmental Protection Agency *Guidelines for*

Exposure Assessment and the 1993 Science Advisory Board draft review of the *Risk Assessment Guidance for Superfund: Volume 1 -- Human Health Evaluation Manual*, support such efforts (Keenan, 1994:226). Until the late 1980s computational methods for assessing uncertainty with much complexity were too cumbersome, but with the arrival of the powerful desktop workstations these computations have become practical (Burmater, 1989:89). Software packages such as DPL (ADA Decision Systems, 1995) decision analysis software and Crystal Ball (Decisioneering, 1993) have the capacity to improve the operational inefficiencies in risk assessment that will be required to most efficiently handle the environmental problems on the horizon.

By using these software to appropriately apply new probabilistic methods of risk analysis and decision analysis techniques, such as VOI, presumptive remedies, and observational methods, tools can be developed to manage the inherent complexities and minimize the conservative assumptions required to efficiently and more confidently characterize a hazardous waste site. The growing magnitude of remediation sites and a dwindling budget has prompted development of more accurate techniques to assess risk and reevaluate how to most effectively spend limited resources on clean-up. As recommended by the Science Advisory Board in their review of EPA's risk assessment guidelines, the decision process should be driven by opportunities for the greatest risk reduction (USEPA, 1990:16). Methods addressed in this research can more objectively estimate the risk distribution and high end risk, which provides much more information than the point estimate, and maintain a better distinction between science and management (Burmater and Appling, 1995:2439-40).

1.4 Current Model

A model has been developed using DPL decision analysis software, by Captain Daniel Clairmont, as a tool for decision makers to optimize site characterization, minimize the resources expended during the RI/FS, and still maintain acceptable levels of risk. "The model uses site specific information and decision maker preferences to select the course of action with the highest expected value at each step in the planning and investigation phase of site remediation" (Clairmont, 1995:1). The model is a series of submodels that represent the phases of the RI/FS process. They take into account VOI and offer other state-of -the-art decision analysis tools such as observational methods and presumptive remedies to streamline the process. The model has been tested using data from Operable Unit 2, POL Storage Area, Wright-Patterson Air Force Base and has generated some valuable results. In scenarios evaluated, the use of the models indicated that the further acquisition of data would not significantly improve the characterization of the site and was therefore, not worth the cost and time spent gathering the information.

1.5 Thesis Objective

The objective of this research is to improve Clairmont's model through the use of probabilistic risk analysis methods and decision analysis tools to further facilitate the remediation decision process to more efficiently allocate limited environmental resources. The model will be improved in the following four ways: (1) use a Monte Carlo probabilistic approach to better estimate the existing human health risk at a given sight, (2) provide a decision analysis process to minimize resources spent on the investigation, (3) offer a better method of estimating the pollutant mean concentration distribution, (4) and

further verify and validate the model once the improvements have be implemented. The research effort will test the value of using probabilistic risk assessment methods and other decision analysis tools to avoid spending resources unnecessarily.

1.6 Thesis Content

The remainder of this thesis consists of four chapters. Chapter Two addresses human health risk assessment and the concepts of probabilistic risk analysis through a review of pertinent literature. It also presents how the current model used decision analysis techniques to streamline the RI/FS decision process. Chapter Three focuses on the improvements to the model that show how a probabilistic risk assessment using the Monte Carlo method provides much more information from which to make more informed decisions. Specifically, the methodology provides a method to quantify and separate uncertainty and variability which is vital to risk analysis. Chapter Four is where the results of testing the model on Operable Unit 2, Wright-Patterson Air Force Base, Ohio, and Site 4, Air Force Plant 44, Arizona will be presented to show how the model could have limited resource expenditure if it had been used. The results also provide some analysis on the conservatism of the RME guideline methods discussed here. Chapter Five provides the conclusions of the research effort and discusses opportunities for follow on research.

2. Literature Review

2.1 Introduction

The following chapter provides a general review of risk assessment (RA) and the current state of affairs in the field as they pertain to the use of probabilistic risk assessment (PRA). It begins with a brief historical review of how the field has evolved and why there is need for more scientifically based methodologies. The basic theory of the EPA's guideline risk assessment methodology and an alternative Monte Carlo method for characterizing risk are addressed. A review of how the original model makes its recommendation is discussed. The fundamental theories established in this chapter lay the foundation for Chapters 3 and 4.

2.2 Historical Review of Risk Assessment

Relative to other scientific disciplines, risk analysis is a new field (Covello, 1993:1). It has been developed within the last five decades and subsequently practiced in the areas of finance, nuclear power plant construction, applications of medicines, human health, and other areas where risks are involved. Specifically, human health risk due to hazardous waste disposal is considered to be in its infancy stages as a scientific discipline (Duplancic, 1989:68). The practices of RA are not as objective as other well established disciplines and, as shown in Chapter 1, the current guidelines and procedures are not widely accepted as appropriate within the field (Cullen, 1994). The following provides a perspective of how the discipline has evolved to its current state.

2.2.1 Initial Guidelines to Risk Assessment Facing the environmental dilemma of the 1970's, federal agencies developed their own procedures, specific to their own interest,

for assessing human health risks due to chemicals. The subjective decision making process of these procedures was scrutinized by congress, scientists, industry, and the public (National Research Council, 1983:2). In response, Congress initiated a review of the institutional methods of RA within the federal government in the early 1980's. The National Research Council (NRC), under direction of the National Academy of Science (NAS), was instructed to evaluate the ad hoc methods of RA being used at the time. The NRC concluded its study in 1983 with the publication of its landmark document Risk Assessment in the Federal Government: Managing the Process, which made 10 recommendations to improve RA within the federal government (NRC, 1983). The NRC report has had a tremendous impact on the evolution of the science of human health RA as shown by the adaptation and implementation of its recommendations by the EPA and practically every state environmental regulatory agency (Burmester and Appling, 1995:2431).

An objective of the study of particular interest was to assess the merits of separating RA from risk management. The Council strongly encouraged a clear and distinct separation between RA, which is the scientific and objective procedure of estimating risk, from risk management, which is the decision process of considering technical, social, economical, political, and other factors to determine a remediation strategy (NRC, 1983:151). Prior to the study there was a lack of knowledge and understanding in the field which created uncertainty about the estimated risk. A subjective safety factor schema was devised by analysts who in their expert judgment, were supposed to be objective, to ensure that even with the given uncertainty the risk would not be

underestimated. This schema, though changing through the evolution discussed in this research, is still prevalent today. This type of safety adjustment is considered to cross the boundary between RA, which considers the information objectively and scientifically, and risk management, which considers the social and political aspects of risk analysis (Covello, 1993:233). To maintain a clear distinction between the two, the NRC recommended the development of uniform inference guidelines to establish more objective methodologies for conducting RA. This recommendation was the first major step to create a more scientifically based RA process.

2.2.2 EPA's Response to the NRC's Recommendations In response to the NRC's recommendations and in efforts to meet the requirements of CERCLA, the EPA developed a series of guidelines on human health RA. Since the focus of this research is on the investigation phase of site remediation, emphasis is placed on guidelines governing RA. The guidelines governing the process evolved primarily into a pair of documents entitled the Human Health Evaluation Manual, which provides guidance for characterizing human health risk, and the Environmental Evaluation Manual, which provides guidance for characterizing environmental risk at Superfund sites (USEPA, 1989c:xv). These are addressed primarily to risk assessors conducting the RAs, and provide a guiding structure to ensure assessments are thorough and consistent with the agency's view.

2.2.3 Relative Risk As the environmental era of the 1970's and 1980's progressed it was clear the environmental problems had grown to a point beyond where anyone had anticipated. This country was facing an environmental dilemma of unprecedented scope (SAB, 1990:1). With limited resources, the EPA realized that its previous reactive

posture would not suffice to manage the problems. Recognizing not every problem could be or needed to be remediated, the EPA realized some sort of prioritization method had to be devised. To deal with this burden, the EPA embraced the concept of relative risk in 1986 to aid in determining where to allocate scarce resources to numerous problems. A group of 75 senior career managers were convened to compare the risks posed by 31 general environmental problems which resulted in a report titled Unfinished Business: A Comparative Assessment of Environmental Problems (SAB, 1990:2). The objective of relative risk is to quantify the risk posed by a problem to compare it to other problems for prioritization purposes. Every environmental problem poses some level of risk to human health. By prioritizing the risk, resources can be used on the highest priority risk first to ensure that the greatest opportunity for risk reduction can be realized (SAB, 1990:16).

To evaluate its progress between 1986 and 1990, the EPA requested that the EPA Science Advisory Board review the results of the report, review changes made to implement its recommendations, and make further recommendations to improve the relative risk process. One of the key findings of this review was the importance of the RA methodology to the determination of relative risk. In order to assess health risks, compare them, and determine the highest priority risks, the SAB recommended that improvements should be made to the analytical methodologies for assessing risk (SAB, 1990:18). They emphasized the need for the development of more rigorous, scientifically based methodologies. It was clear that the RA methodology would play a dominant role and partially drive this country's \$100 billion annual investment in environmental protection (Graham *et al.*, 1992:409). Recognizing the paramount importance of RA methodologies,

the EPA has made significant efforts to improve and develop the guidelines to foster more objective methods of assessing risk.

The problems discussed in Section 1.1 resulted in pressure from academia, industry, congress, and the public for the EPA to develop more scientifically based procedures to further delineate RA from risk management (Graham *et al.*, 1992:409; USEPA, 1992a:22888). As a result, the EPA went through a significant paradigm shift with the publication of a memorandum titled "Guidance on Risk Characterization for Risk Managers and Risk Assessors" in February of 1992. The view of the EPA shifted from a deterministic point estimate to a focus on the high end risk of the risk distribution (USEPA, 1992b:16,23). In May of 1992, the EPA officially adopted this new paradigm with the publication of its Guidelines for Exposure Assessment in the Federal Register (USEPA, 1992b). There were several techniques that were possible candidates to improve the process. But before the introduction of powerful desktop computer work stations, none was practical for application in the field. With the development of software and computers as early as 1989, the Monte Carlo RA method (discussed in section 3.4) became a potential solution (Burmester and von Stackleberg, 1989). The EPA has seriously considered this technique as the next step in the evolution of RA.

The EPA has sponsored a series of workshops to develop the application of Monte Carlo simulation within human health risk (Graham *et al.*, 1992; Haines *et al.*, 1993). The most recent of these was the "Workshop on Monte Carlo Analysis" in May of 1996 which was convened to discuss technical issues concerning how to perform the analysis. These efforts provide evidence of the general acceptance of the technique as a possible option

and the need for more objective methods to conduct RAs. In the past six years, literature has been published concerning the Monte Carlo method (Burmater and von Stackleburg, 1989; Burmaster and von Stackleburg, 1991; Thompson *et al.*, 1992; Finley *et al.*, 1994; Burmaster and Appling, 1995). Little has been published discouraging the use of this technique; instead, the fundamental issue has been on whether the deterministic method is too conservative or whether it approximately estimates the high end risk (Cullen, 1994). Before the benefits and drawbacks of Monte Carlo method are discussed, a general review of the EPA's deterministic guideline structure for estimating risk is necessary.

2.3 EPA's Deterministic Risk Assessment Structure

The following is a brief review of the structure for estimating the risk at a Superfund site in accordance with the RA Guidance for Superfund (Volume 1) (USEPA, 1989c). For a more detailed explanation, the reader is encouraged to reference the original document along with other documents that discuss the topic (NRC, 1983; USEPA, 1992b; Covello, 1993; Burmaster and Appling, 1995). The Superfund guidelines are followed in this research because other federal laws such as the Clean Air Act, Clean Water Act, and Safe Drinking Water Act follow similar if not identical RA procedures (Burmater and Appling, 1995:2432). First it is critical that risk, as discussed in this research, be defined. Risk has different meaning in different disciplines, but in this research it refers to the possibility of an adverse human health effect due to exposure to some environmental pollutant. There are two general types of risk that an individual could be exposed to in a given scenario. The first is a risk of some noncarcinogenic adverse effect that is often curable, but could be fatal. The other type of risk is a carcinogenic

effect that is considered fatal. The method of assessing human health risk is complex and is developed as its four fundamental components are addressed.

2.3.1 Hazard Identification Chemicals of particular interest are evaluated to determine if they pose an adverse health risk. This risk can be either carcinogenic or noncarcinogenic. Different conditions and events under which the agent may pose health risks are evaluated to identify the hazards associated with the agent (Covello, 1993:5). This type of analysis can be done on-site, but is usually done prior to the assessment in a laboratory setting. Chemicals are classified as carcinogenic or noncarcinogenic once this type of evaluation has been completed.

2.3.2 Dose Response Assessment After a chemical has been determined to pose some health risk, the next step is to conduct a dose response assessment. The assessment attempts to establish a relationship between the exposure dose in a given scenario and the adverse health effect. The purpose of the dose response assessment is to determine either a reference dose (RfD) for noncarcinogens or a slope factor (SF) for carcinogens to be used in RAs (USEPA, 1989c:Ch 7, 1).

In estimating the RfD, it is important to understand that any chemical that enters the body has some effect. At some level the chemical begins to produce some adverse effect the body can no longer alleviate through its normal physiological defenses. This dose is referred to as the no-observed-adverse-effect-level (NOAEL) (USEPA, 1989c:Ch 7, 1). Laboratory tests, epidemiological studies and other data are used to establish a NOAEL for different chemicals. Since experimentation on humans is considered unethical, animal experimental studies or inadvertent prolonged human exposure are used

to extrapolate the NOAEL (Burmester and Appling, 1995:2433). If available, both types of studies are used to estimate the NOAEL. When there is sufficient data to establish a NOAEL from human exposure, an uncertainty factor of 10 is used because of the lack of control in the experiment and the uncertainty due to human variability (Covello, 1994:233). When animal studies are used, a safety factor of 100 is used due to the uncertainty in extrapolating the effect between animals and humans (Covello, 1994:233). The total uncertainty factor can be greater than 1000, for particular circumstances, and practically always less than 10,000 (Kimmel, 1990:191). After the estimated NOAEL has been divided by the appropriate uncertainty factor, the resulting number is the reference dose (RfD). The RfD is considered an estimate of the daily dose per unit weight that an individual can be exposed to with a substantial degree of safety of not experiencing an adverse effect (USEPA, 1989c:Ch 7, 3). Reference doses for different chemicals are published in the Superfund Chemical Data Matrix (USEPA, 1994).

When considering carcinogenic effects, there is different underlying theory that governs the dose response assessment. Because of our limited understanding of the mechanism of cancer, carcinogens are considered no-threshold chemicals (USEPA, 1989c:Ch 7, 10). Unlike noncarcinogens that the body has a tolerance threshold against, it is theorized that carcinogens at any dose, even one molecule, have the potential to cause cancer (USEPA, 1989c:Ch 7, 10). The question now might be: "why bother with a dose response assessment if there is a zero threshold tolerance?" In the environment, it is not currently economically feasible to either detect or clean up to a zero level. If a carcinogen is introduced into the environment, it is not feasible to completely remove the risk agent,

so some level of risk must be accepted. The remediation strategy is designed to remove the carcinogen to an acceptable level of risk. Since there are other carcinogens possibly present in any environment that produce some background cancer, a foreign risk agent increases the probability of incurring cancer by some amount. The SF is an estimate of this increased probability of incurring cancer per average unit dose of the chemical (USEPA, 1989c:Ch 7, 10). It provides an indication of the chemicals carcinogenic potency and is sometimes referred to as the cancer potency factor (CPF). Similar to noncarcinogens, controlled human experiments for determining the SF are not an option and the procedure for extrapolating a SFs from non-human data is rigorous (USEPA, 1989c:Ch 7, 11; Burmaster and Appling, 1995:2432).

Though the tolerance for carcinogens is a zero threshold, experimental animals are dosed with high levels of carcinogens to differentiate between background cancer and to ensure that cancer induced by the chemical is observed (USEPA, 1989c:Ch 7, 11). An experiment usually consists of an experimental group, which is exposed to the chemical, and a control group, which is under identical conditions without exposure to the chemical. At low doses few animals incur cancer in the experimental group and it is difficult to determine whether the cancer observed in the experimental group is due to the risk agent or the background risk of cancer. This also makes it difficult to determine an increased probability of cancer above that of the control group. In order for scientists to observe a substantial amount of cancer above the control group and make reasonable inferences about the chemicals carcinogenic potency, high doses must be used on the animals.

Elaborate models and techniques are used to estimate the increased probability (USEPA, 1989c:Ch 7, 12).

This type of procedure produces two general types of uncertainties. There is uncertainty in extrapolating from a high dose region to a low dose region of interest and from extrapolating from animals to humans. To account for the uncertainty, the procedure for estimating the SF includes various conservative assumptions (Covello, 1993:233). These uncertainties may account for the majority of the uncertainty within RA and have been the issue of much debate within the field (Gaylor *et al.*, 1993). It is not the intent of this research to discuss the validity of these procedures, but only to briefly point out the source of the uncertainties in toxicological input parameters, which manifest themselves in the final risk estimate. The SFs for chemicals that have been tested can be found in the Integrated Risk Information System (IRIS) (USEPA, 1994).

2.3.3 Exposure Assessment For a risk to exist, there must be a chemical source, an exposure route, and an exposure point, which make up the exposure pathway (USEPA, 1989c:Ch 6, 8). The source is a point where the risk agent is released and allowed to migrate into the environment. The exposure route is a transport medium by which the risk agent is carried to the individuals in the population. Some direct transport media are soil, tap-water, groundwater, surface water, and air. Indirect transport media include produce, game food, fish, breast milk, and other non-direct transport methods. The location where the population contacts the contaminated media is considered the exposure point and the three exposure components determine the exposure pathway. There are three potential

intake routes that an agent can use to enter the body: the inhalation, oral or ingestion, and the dermal contact route (USEPA, 1989c:Ch 6, 17).

2.3.3.1 General Exposure Intake Equation To calculate the estimated exposure dose, the guidelines provide established exposure intake equations that all have a common underlying theory that governs the method of calculating the exposure. The different equations consist of variables that contain certain fundamental elements that are related to the chemical, population behavior, and an assessment determined averaging time (USEPA, 1989c:Ch 6, 19). These elements provide information that allow the assessor to determine the intensity and frequency of the exposure. The general Equation (2.1) for calculating chemical intake is shown below (USEPA, 1989c:Ch 6, 21). The three basic categories of information are broken down in the definition of the variables.

$$\text{Intake } \left(\frac{\text{mg}}{\text{kg} \cdot \text{day}} \right) = \frac{C \cdot CR \cdot EFD}{BW \cdot AT} \quad (2.1)$$

“Where:

Chemical-related variable

C = chemical concentration; the average concentration contacted over the exposure period

Variables that describe the exposed population behavior

CR = contact rate; the amount of contaminated media contacted per unit time or event

EFD = exposure frequency and duration; describes how long and how often exposure occurs.

BW = body weight; the average body weight over the exposure period

Assessment-determined variable

AT = averaging time; period over which exposure is averaged (days).”
(USEPA, 1989c:Ch 6, 21)

In accordance with the guidelines, when the risk manager considers the risk in the decision making process, it should be the risk that is associated with the reasonable

maximum exposure (RME) that is expected to occur in the present and in the future (USEPA, 1989c:Ch 6, 4). All the factors in the exposure equations above should be estimated such that, when combined, the result is an estimate of the RME. Most of the variables have ranges, but it is not reasonable to use maximum values for all factors to estimate the RME because doing so would surely result in an estimate that is too high (USEPA, 1992a:22922).

2.3.3.1.1 General Exposure Intake Variables Certain values and percentiles of values for each variable are recommended for use in the exposure equations. The average chemical concentration is used because it is assumed that an individual will be exposed over an extended period of time and experience the average concentration. There is usually a significant amount of uncertainty in estimating the C. Because of the uncertainty in estimating C, the 95% upper bound confidence limit (UBCL) of the arithmetic mean is used for the variable (USEPA, 1989c:Ch 6, 19).

The CR is a general term for the amount of contaminated media contacted per unit time or event. Depending on the availability of data, the CR should represent the 90th or the 95th percentile. When combining variables to estimate the contact rate, the individual variables should be estimated such that their combination estimates the 95th percentile contact rate.

The EFD is used to estimate the total time of actual exposure and includes an exposure duration and frequency term. An estimate of the duration of the exposure time per contact is sometimes used in the calculation of total exposure time. If statistical data are available, the guidelines require the use of the 95th percentile for total exposure time

(USEPA, 1989c:Ch 6, 22). If data is not available the guidelines suggest that a conservative estimate be used for these input parameters. The factors in the numerator describe the amount of chemical that an individual would experience over the duration of the exposure. This value is normalized for body weight and averaging time to calculate an average exposure rate per time unit. The guidelines recommend average weight of the population for BW (USEPA, 1989c:Ch 6, 23). The AT is dependent on the toxicological effect being assessed and is critical to properly assessing the potential risk (Hattis and Burmaster, 1994:720).

There are three types of effects that determine the appropriate AT. For noncarcinogenic affects there are generally long-term toxic effects and short term acute toxic effects. When a chemical is suspected to cause long-term toxic effects, the exposure rate is averaged over the exposure duration. Because of the rapid effect of acute toxicants, the exposure rate is averaged over the shortest exposure period that could produce an effect (USEPA, 1989c:Ch 6, 23). In accordance with the theory of the mechanism of cancer, the exposure rate for carcinogens is prorated over a lifetime. There is an entire section in the guidelines that addresses what to consider when selecting the appropriate averaging time (USEPA, 1989c:Ch 6, 23).

The scenario dictates which specific factors must be considered in the exposure assessment and what values to use for each factor. The specific form of the exposure equation depends on the exposure pathway and the intake route, but they are generally classified by the three intake routes (Burmaster and Appling, 2435). A particular scenario will be used to illustrate the equations for the three intake routes that will be useful for

understanding the calculations in the methodology in chapter 3. After the presentation of the each equation, parameters specific to each equation will be discussed.

2.3.3.1.1.1 Ingestion Route Oral ingestion is one form in which a risk agent can enter the body. The media containing the chemical is input into the body's digestive system where the risk agent can be absorbed into the blood stream through the digestive process. There are many possible pathways with different equations for calculating the intake due to ingestion of chemicals. The equation for ingestion of contaminated groundwater (2.2) will be used to illustrate a common formula used for this intake route.

$$\text{Intake} \left(\frac{\text{mg}}{\text{kg} \cdot \text{day}} \right) = \frac{\text{CW} \cdot \text{Ing_R} \cdot \text{EF} \cdot \text{ED}}{\text{BW} \cdot \text{AT}} \quad (2.2)$$

“Where

CW = Chemical concentration in water (mg/L)

Ing_R = Ingestion rate (L/day)

EF = Exposure frequency (days/year)

ED = Exposure duration (years)

BW = Body Weight (kg)

AT = Averaging Time (period over which exposure is averaged -- days).”
(USEPA, 1989c:Ch 6, 35)

CW and EF are pathway specific, and AT is dependent on the effect being assessed.

Conservative recommended point estimates are provided in the guidelines for all the other exposure factors.

2.3.3.1.1.2 Dermal Contact Route A second possible entry into the body is absorption through the skin. A chemical can come in contact with the skin directly or as a contaminant within a media. Dermal contact can occur while showering, swimming, or playing in soil. In calculating the intake for the ingestion and inhalation route it is assumed that the amount of chemical, or dose, taken in is the amount that the body absorbs into the

blood stream. This is not an accurate portrayal of reality (Finley *et al.*, 1994:549). Some percentage of the chemical is excreted before it enters the blood stream (such as in the lungs) or never absorbed in the digestive tract. One hundred percent absorption is a conservative, but reasonable, assumption because the percentage is usually small in these two intake routes. The skin, however, is designed to repel water soluble chemicals. Depending on the chemical, the skin absorbs only a fraction of the dose with which it comes in contact. The amount that penetrates the skin is the contact dose multiplied by the chemical's absorption factor for soils or its permeability constant for water and is called the absorbed dose (USEPA, 1989c:Ch 6, 4). The equation (2.3) for dermal contact with chemicals in water is used to present the formula and other factors for estimating dermal contact absorbed dose.

$$\text{Absorbed Dose } \left(\frac{\text{mg}}{\text{kg} \cdot \text{day}} \right) = \frac{\text{CW} \cdot \text{SA} \cdot \text{PC} \cdot \text{ET} \cdot \text{EF} \cdot \text{ED} \cdot \text{CF}}{\text{BW} \cdot \text{AT}} \quad (2.3)$$

“Where

CW = Chemical Concentration in Water (mg/L)
 SA = Skin Surface Area Available for Contact (cm²)
 PC = Chemical Specific Dermal Permeability Constant (cm/hr)
 ET = Exposure Time (hours/day)
 EF = Exposure Frequency (days/year)
 ED = Exposure Duration (years)
 CF = Conversion Factor (1L/1000 cm³)
 BW = Body Weight (kg)
 AT = Averaging Time (period over which exposure is averaged -- days)”
 (USEPA, 1989c:Ch 6, 41).

CW, PC, and EF are pathway and chemical specific, and AT is dependent on the effect being assessed. Conservative recommended point estimates are provided in the guidelines for all the other exposure factors.

2.3.3.1.1.3 Inhalation Route Inhalation is the last route by which a foreign agent can enter the body. It can be directly carried by the air or as a contaminant of particulate matter that are breathed. Once again there are a multitude of exposure pathways and equations that can be considered. The equation for inhalation of airborne chemicals (2.3) is used to illustrate a typical intake calculation through this route.

$$\text{Intake} \left(\frac{\text{mg}}{\text{kg} \cdot \text{day}} \right) = \frac{\text{CA} \cdot \text{Inh_R} \cdot \text{ET} \cdot \text{EF} \cdot \text{ED}}{\text{BW} \cdot \text{AT}} \quad (2.4)$$

“Where

CA = Chemical Concentration in Air (mg/m³)
 Inh_R = Inhalation Rate (m³/hour)
 ET = Exposure Time (hours/day)
 EF = Exposure Frequency (days/year)
 ED = Exposure Duration (years)
 BW = Body Weight (kg)
 AT = Averaging Time (period over which exposure is averaged -- days).”
 (USEPA, 1989c:Ch 6, 44)

CA, ET, and EF are all pathway specific, and AT is dependent on the effect being assessed. Conservative recommended point estimates are provided in the guidelines for all the other exposure factors.

2.3.3.2 Estimating the Reasonable Maximum Exposure The process of estimating the RME is not entirely objective. The guidelines recognize that the recommended risk variable percentiles cannot be fixed. If, in the opinion of the remedial project manager (RPM), percentiles other than those recommended in the guidelines are a better value for estimating the RME, then these percentiles can be used (USEPA, 1989c:Ch 6, 19). More subjectivity is introduced when the risk assessors must determine all the other pathway specific factors to estimate the RME. The professional interpretation of “reasonable,” “maximum,” and other key terms in the guidelines becomes critical to final risk estimate

that is presented to the risk manager (Duplancic, 1993:52). Due to the problems mentioned in Section 1.2, regulators have been criticized for making subjective determinations that produce risks that are too conservative.

2.3.4 Risk Characterization The concluding component of RA is risk characterization where all the information gathered in hazard identification, dose response, and exposure assessment are integrated to evaluate the possibility and magnitude of risk. Once the appropriate intake or absorbed dose is calculated for each possible intake route, the risks can be calculated. For noncarcinogenic effects the dose is divided by the appropriate RfD to calculate a noncancer hazard quotient (USEPA, 1989c:Ch 8, 11). The hazard quotients for the different intake routes and across pathways are summed to determine the noncarcinogenic risk to a population due to a chemical. The hazard quotients for different chemicals can be summed, as long as they are for the same population, to estimate a total hazard quotient. Hazard quotients greater than 1 indicates the population is exposed to doses of the chemicals that may produce unacceptable noncancerous effects (USEPA, 1989c:Ch 8, 11). For carcinogenic risks the chronic daily intake (averaged over a 70 year life span) for each intake route is multiplied by the appropriate SF to determine the cancer risk. The cancer risk for each chemical is found by adding the cancer risks for each chemical specific exposure pathways. Then a total cancer risk is calculated by summing the risks to a particular population for all the chemicals present. It is important to note that the total estimated risk is specific to the population used to estimate the risk.

A vital element of risk characterization is presenting the estimated risk in a format that encompasses the variability and uncertainty. The estimated RME risks for each

population are usually presented in tabular format as a series of point estimates representing the estimated risk for each exposure pathway for a specified population. The tables may include the average estimated risk, but usually include little if any mention of range or likelihood of the estimated risks . The discussion of the inherent uncertainties and variability, if addressed, are usually buried in the volumes of documents associated with the assessment (Haines, 1993:671).

The field of RA has evolved to recognize that dealing with variability and uncertainty as mentioned above is neither appropriate or efficient. Presenting risk as a simplified numerical value when variability and uncertainty in the estimated risk inevitably exist is always incomplete and can often be misleading (USEPA, 1992b:16). Though the guidelines recognize that the input values have ranges and probabilities, these variable descriptors are not used in the calculations (USEPA, 1989c:Ch 8, 19). Calculations using a single value to represent a variable that is random in nature have made it difficult to quantify and distinguish between uncertainty and variability after the calculations have been made. Another, subtle, but critical factor that must be addressed in accordance with the new guidelines is the clear distinction between variability and uncertainty (USEPA, 1992a:22929). The analysis of uncertainty has consisted primarily of a qualitative discussion about the uncertainty once the risk estimate has been calculated. Quantitative uncertainty analysis using the guideline structure has proven very difficult because of the difficulty in estimating the resulting uncertainties in the final risk estimate (Morgan and Henrion, 1990:183).

2.4 Monte Carlo Method

Many problems have been pointed out with the guideline structure for estimating the full range of risks and quantifying the uncertainty and variability. Many have suggested and criticized, as discussed in Section 1.2, that the guideline method generates risks that are beyond a reasonable maximum (Hattis and Burmaster, 1994:715). It is not the intention of this research to argue that the selected default values are appropriate or too conservative, only that from the guideline deterministic method it is difficult to quantify the uncertainty, variability, and conservatism. The Monte Carlo method provides an alternative to the deterministic point estimate approach outlined in the guidelines. It uses the guideline structure and enhances the process to what the EPA considers a new level of refinement (Finley and Paustenbach, 1994:54). The Monte Carlo method is specifically discussed in Section 3.3. The method offers a more scientifically based process to utilize the estimated variability and uncertainty for each variable to estimate the risk distribution, its variability, and its uncertainty. The results of the using the method provide the decision makers more information from which to make informed decisions and allows for the use of decision analysis tools to optimize the decision making process.

2.5 Drawbacks to Probabilistic Risk Assessment

There has been some discussion in the literature about the possible problems of using the Monte Carlo method. Some professionals argue that there is security in the fundamental consistency of the EPA guidelines (Hattis and Burmaster, 1994:714). To move away from the structured guidelines could jeopardize the successful progress made in the last two and a half decades. There is also concern that there has not been sufficient

testing and analysis of the method to ensure that it is protective of human health (Hattis and Burmaster, 1994:714). The safety in the deterministic guideline structure is in the simplicity of the calculations. All the calculations in the deterministic method could be done on the back of an envelope with a hand-held calculator. The Monte Carlo method relies heavily on the use of computers to run the simulation. The artificial processing during the simulation is conducted by the computer and makes it difficult to conduct quality assurance of the calculations (Finley and Paustenbach, 1994:55). The artificial processing has raised the issue of greater possibility for misapplication, errors, or purposeful manipulation of the simulation (Burmaster and Appling, 1995:477).

Another drawback has been the development of the individual distributions to use within the simulation. To gather the information to develop the input distributions requires a significant amount of resources that may not be worth the improved assessment. Others have argued that the method has internal limitations due to some of the assumptions made in the simulation (Thompson *et al.*, 1994:54). One assumption that has been highly criticized is the assumption that all the input distributions are independent of each other. Some of these limitations are addressed in the methodology of this research. Though the Monte Carlo method has some limitations, critics do not fail to recognize that if developed and applied with professional judgment, the Monte Carlo technique provides a scientifically based approach to conduct RA. It allows the assessor to better quantify uncertainty, separate uncertainty and variability, and present risk to encompass uncertainty and variability (Thompson *et al.*, 1992:53).

2.6 How Clairmont's Model Dealt with the Task

Clairmont's model does an excellent job of encompassing the scope of the RI/FS process in DPL (ADA Decision Systems, 1995). The following will be a review of how the model uses decision analysis tools, the calculated risk, and decision maker inputs to make its recommendations. For details of how the model accomplishes the analysis the reader is encouraged to reference the original document (Clairmont, 1995). In the RI/FS process, the risk manager is faced with determining the path through the remediation process. The investigation phase of the process includes the preliminary assessment (PA), site investigation (SI), and varying stages of the RI such as the 30% RI, 60%RI, and the 100% RI. Once a possible risk has been identified, a PA is performed to determine if a RA is warranted. If sufficient evidence is found in the PA to ensure that a risk exists, the manager can skip the SI and proceed directly to the RI (National Archives and Records Administration, 1993:52). If additional information is required beyond the PA, the manager can use the SI to ensure that a risk either does or does not exist (National Archives and Records Administration, 1993:). Once it has been determined that there is a possible risk, the RI is used to estimate the extent of the risk. After the risk has been assessed and remediation is required, the feasibility study ensures proper remedial strategies are developed and evaluated. A primary concern in the feasibility study is to ensure that the selected remediation technology meets the remediation clean-up goals. If the assessed risks are at an acceptable level, as defined by the owner, regulator, and other interested parties, the manager can choose to take no further action (NFA). Anywhere along the process where the manager feels there is a sufficient risk that requires immediate

response, a removal action (RA) can be accomplished. Figure 2-1 will be used to illustrate the range of decision strategies a manager can select.

Strategy	Site Investigation	Remedial Investigation			Removal Action	Feasibility Study		NFA
		30%	60%	100%		Presumptive Remedies	Investigate All	
Baseline Case	→ 1 →	→ 2 →	→ 3 →	→ 4 →			→ 5 →	→ 6
Shortened Study		→ 1 →	→ 2 →			→ 3 →		→ 4
Quick Action					→ 1 →			→ 2

Figure 2-1: Strategy Generation Table for the PA Decision (Clairmont, 1995:37)

2.6.1 RI/FS Decision Strategy The alternatives in the table are those available to the manager after the PA has resulted in a possible risk. The baseline strategy is a path that requires the most information to be gathered. After every study has been conducted all feasible remediation alternatives are investigated to determine the one that will most likely meet the clean-up goals for the site. No VOI analysis is performed to determine the benefits of each additional study. It is the longest and most costly because it consists of every possible study in the process, but it consists of less uncertainty than the other paths. The manager can choose the shortened study strategy that is less costly and shorter in duration, but with more uncertainty due to the lack of information from the missing studies. The site is investigated using VOI tools so that information is gathered in subsequent phases of the RI only if the benefit gained is expected to outweigh the cost of the acquired information. The cost of gathering the additional information will be justified only if the additional information is expected to change decision strategy, which results in

a reduced total cost greater than the cost of the information. Uncertainty plays a major role in this path strategy because if it cannot be quantified with some confidence then it is difficult to determine the cost trade-offs between reducing uncertainty and proceeding to clean-up. Both observational methods and presumptive remedies are used to streamline the feasibility study. The method by which the model applies these techniques to the risk assessment process is discussed in Section 2.6.3

The final strategy is a quick action, where no information is gathered and the manager selects to remediate the site without regard to a risk assessment. The feasibility study would be done with the available information after the PA. This is the most conservative path because the site is remediated regardless of the extent of contamination. This path is conservative but at the expense of incurring significant clean-up costs that may be unnecessary.

There is also a potential liability if the clean-up goals are not met by improperly characterizing the site. Most Superfund site owners, who pay for the remediation, view risk in economic terms (Elliot, 1992:272). There are unnecessary clean-up costs if the risk is overestimated and future liability costs if the risk is underestimated, both of which can be significant. The challenge for the manager is to take this complex process and determine the most cost-effective path between the baseline and quick action strategies to determine the optimal decision strategy.

2.6.2 Characterizing the Risk Distribution To use decision analysis tools it is important to know the possible outcomes of the risk and their likelihood. The model defined a low, medium, and high risk as the three possible outcomes of risk. Within a risk

assessment there is a clearly acceptable (CA) and clearly unacceptable (CUA) risk level that are predetermined to establish a level at which action will definitely be taken. For a noncarcinogenic risk, there are no guideline levels of CA or CUA levels only that at a HI of one or greater there is an increased level of concern. In the model, they are defined by decision maker preferences. The EPA has established standards of 10^{-6} (a unitless probability of an individual developing cancer [USEPA, 1989c:Ch 8, 11]) as CA and 10^{-4} (unitless) as CUA for carcinogenic risks (NRC, 1994:3), but the site owner or RPM may in their discretion use more conservative values if they choose or if it is warranted by the circumstances. In this research, if the risk estimate is above CUA, then the risk is considered high and the manager will decide to cleanup. If the risk estimate is below the CA, then the risk is considered low and the manager can decide to take NFA. Because of other factors involved with hazardous waste sites remediation, it is important to make clear and understand that the decision maker can decide to clean up regardless of the results of the RA. These decisions are from a perspective of what the decision support model would recommend based on the likelihood of the risk outcomes. If the risk estimate is between the CA and the CUA then the RPM and the site owner must use professional judgment to decide what actions to take. In these cases the decisions are usually conservative with clean-up as the alternative selected. The three alternatives are mutually exclusive and collectively exhaustive so the next challenge was to quantify the probability for each of three defined outcomes.

2.6.2.1 Distribution of the Mean Concentration In accordance with the assumptions in the initial model, the conservative guideline recommended values are used

for the majority of the exposure variables and other site specific variables are represented by conservative estimates. The information gathered in each subsequent phase of the RI consists only of additional chemical concentration samples that are used to reduce the uncertainty in the estimate of the mean concentration (Clairmont, 1995:84). The model assumed that the estimated risk consists of a constant, termed the risk multiplier, made up of all the deterministic input values in the risk equation multiplied by the estimate of the mean concentration. The risk estimate changes when the estimate of the mean concentration changes as more samples are gathered in each subsequent phase. To establish the required probabilities for each outcome, the model focused on the distribution of the mean concentration, which was the only variable represented as a stochastic variable.

Clairmont made some simplifying assumptions about the distribution of the mean concentration. Using the Central Limit Theorem (CLT), the model assumes that given a random sample (X_1, X_2, \dots, X_n) of chemical concentration with mean μ and variance σ^2 , if the sample size n is sufficiently large, then \bar{X} has approximately a normal distribution with a mean equal to the population mean and a variance equal to the variance of the population divided by the number of samples, n , or the standard error (Devore, 1995:232). There is no discussion of when the sample size is sufficiently large enough to apply the CLT (Clairmont, 1995:29). This assumption may or may not be appropriate when the sample size is small and the distribution is highly skewed, such as those found for pollutant concentrations (Gilbert, 1987:164; USEPA, 1992c:4). The use of this simplifying assumption is analyzed in section 3.5.3. The mean concentration therefore was defined by

a normal distribution with a mean of \bar{X} and the standard error found with the sample concentrations samples available at each phase of investigation.

2.6.2.2 Estimating the Distribution of Risk The model then used the normal mean concentration distribution described by the sample mean and the standard error to derive an estimate of the risk distribution. By multiplying the estimated mean concentration distribution by the risk multiplier, the model was able to estimate the risk distribution. This type of mathematical operation is governed by the statistical rules of linear combinations. The rules state that if a distribution is multiplied by a constant the transformed distribution will maintain its shape with a mean equal to the original mean multiplied by the constant and a variance equal to the original variance multiplied by the square of the constant (Devore, 1995:238). The distribution of risk was used to establish the probabilities that the risk would be high, middle, or low. The general scenario in Figure 2-2 illustrates how this is done.

2.6.2.3 Risk Probabilities The CA and CUA levels are defined in the model according to the decision maker preference. The area under the curve to the left of the CA level, marked as area A, quantifies the probability that the risk is low. The area under the curve between CA and CUA, marked as area B, quantifies the probability that the risk is

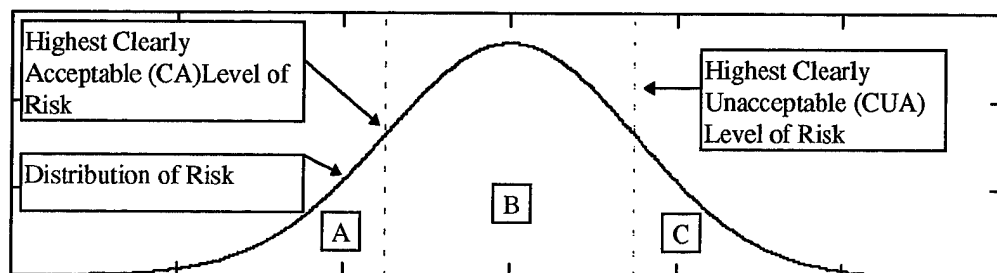

Figure 2-2: Risk Probability Distribution Graph (Clairmont, 1995:85)

medium and the area to the right of CUA, marked by area C, quantifies the probability that the risk is high. All these areas and probabilities can be quantified with the estimates of the risk distribution parameters as defined above. The distribution and the probabilities are affected by changes in the standard error as the sample size increases in each subsequent phase. This will have a tendency to tighten the variance and pull in the tails of the risk distribution. If the distribution has a small probability of the risk being low, the additional samples would more than likely pull in the low end tail and not make a difference in the decision to clean up. In this case, the additional samples may not be worth the cost. This analysis is based on the assumption that the estimated mean concentration is the best available information at the time the decisions are being made.

2.6.3 Decision Analysis Tools DPL is used to manage the complex calculations required to apply VOI, observational methods, and presumptive remedies to make recommendations on the optimal path strategy at every stage in the decision process (Clairmont, 1995:40-86). The model uses utility theory to calculate a utility value for a large number of combinations of cost and duration. The utility value is based on the weight the decision maker assigns to cost and duration (Clairmont, 1995:61-63). The highest utility indicates a path strategy that outperforms other alternatives in accordance with the importance of time and money to the decision maker. The recommendations are made based on the path that maximizes the expected utility. Observational methods are used to characterize the most probable site conditions instead of attempting to characterize the exact conditions by uncertainty reduction (Clairmont, 1995:14). This decision analysis technique has been used in other fields that involve the characterization

of human health risk due to other activities and has proven very useful to more efficiently characterize site conditions. Some authors suggest that these techniques can and should be adopted to human health risk assessment to minimize the cost and duration of the RI (Duplancic, 1989:68; Hattis and Burmaster, 1994:716).

Presumptive remedies are another decision analysis tool, often used in combination with observational methods, to optimize the decision process of characterizing the risk at a site (Clairmont, 1995:14). It involves the presumption that remediation technologies successfully used at other sites with similar characteristics will be suitable for use at the current site. It is presumed that there is no need to evaluate all possible remediation alternatives because there is a remediation technology that has already worked at a site with similar characteristics. The similarity between the two sites is based on two criteria. First the site must be similar in nature or type such as a landfill or groundwater contamination (Clairmont, 1995:68). The second criteria used in the model to determine similarity is that the sites must have similar types of contamination. The specific techniques and the calculations involved in objectively assessing the similarities are specifically addressed in the original thesis (Clairmont, 1995:67-79).

3. Methodology

3.1 Introduction

The following chapter presents a probabilistic risk assessment (PRA) methodology used to more accurately assess and present risk and how this affects the decision support model recommendations. Variability and uncertainty for the input variables are defined and used in a Monte Carlo simulation to better assess the uncertainty of the risk distribution. The specific input distributions and the criteria for selecting them is discussed. An iterative process of evaluating and selecting variables for further investigation is presented to aid the analyst through the investigation. Uncertainty and Variability of the input variable distributions are assessed to determine contribution to variance in the risk distribution, which are important to both value of information (VOI) analysis and decisions made. A method is provided to determine the value of additional chemical concentration samples for reducing uncertainty in the risk distribution. Finally, the possible benefits gained from using a probabilistic risk assessment approach are discussed.

3.2 Deterministic Risk Estimate

Before any probabilistic risk assessment can be conducted, the traditional point estimate risk should be calculated using the default values recommended in the guidelines. It is not required specifically by the guidelines, but it is common practice to compare the deterministic value to the results of the probabilistic risk simulation (Burmaster and Anderson, 1994:478). To better explain the methodology, a simple scenario from Operable Unit 2, Wright-Patterson AFB, OH, will be used for illustrative purposes and for

further use in the analysis of Chapter 4. The assumptions underlying the exposure correspond to a commercial worker exposed to benzene contaminated groundwater. The input exposure values were taken from the actual risk assessment (Engineering Sciences, 1995: Appendix H). Table 3-1 shows the risk variables for the three viable intake routes using Equations 2.2, 2.3, and 2.4. The only variable that was not taken from the original risk assessment is the mean concentration. The calculations for the mean concentration are shown in Appendix A.

The calculations were done in an Excel spreadsheet that will serve as the basic building block of the methodology. From Table 3-1, the estimated reasonable maximum exposure (RME) risk after the RI70% is $2.11 \cdot 10^{-5}$ (a unitless probability of an individual developing cancer [USEPA, 1989c:Ch 8, 11]) from exposure to benzene contaminated groundwater. Since the RME risk is between the clearly acceptable (CA) and the clearly unacceptable (CUA) levels, clean-up would most likely be the remedial action, which was the action taken in this case.

3.3 Monte Carlo Approach

As briefly discussed in Section 1.4, every variable estimated in the exposure equations has some associated variability and uncertainty that manifests itself in the final risk estimate. The term random variable will be used to describe a variable that has some range of possible values. The different values in the range occur more or less frequently according to their likelihood of occurrence. The simplified mathematical models used to represent the likelihood of the values are discussed in the next section. A random variable can be used to represent the uncertainty and/or variability of a variable in the risk

equation. If the variability and/or uncertainty for every variable is discarded by the use of a point estimate, then it is difficult to extract the variability and uncertainty in the risk estimate beyond much more than a qualitative discussion (Morgan and Henrion, 1990:183). Even when uncertainty and variability for variables are quantified, their propagation through mathematical operations for all but the simplest cases are intractable and require elaborate numerical integration (Morgan and Henrion, 1990:183). To discuss the Monte Carlo method, it is important to establish how variability and uncertainty for a random variable can be represented within a probabilistic simulation.

Table 3-1: Deterministic RME Risk Calculations

Cancer Risk due to Benzene in Contaminated Groundwater					
Ingestion Route (tapwater)		Dermal Absorption (showering)		Inhalation (showering)	
CW (mg/L)	0.1722	CW (mg/L)	0.1722	CW (mg/L)	0.1722
Ing_R (L/day)	1	SA (cm ²)	23000	Inh_R (m ³ /hr)	0.6
EF (days/yr)	250	PC (cm/hr)	0.021	ET (hours/day)	0.25
ED (yr)	25	ET (hours/day)	0.25	EF (days/yr)	250
BW (kg)	70	EF (days/yr)	250	ED (yr)	25
AT (days)	25550	ED (yr)	25	K (L/m ³)	0.5
		CF (L/m ³)	1E-3	BW (kg)	70
		BW (kg)	70	AT (days)	25550
		AT (days)	25550		
Intake (mg/(kg-day))	6.02E-4	Absorbed Dose (mg/(kg-day))	7.27E-5	Intake (mg/(kg-day))	4.51E-5
SF((kg-day)/mg))	0.029		0.029		0.035
Intake Path Risk	1.75E-5		2.11E-6		1.58E-6
RME Risk after RI70%	2.11E-5				

3.3.1 Variability Every individual within a given population has a different weight, inhalation rate, response to a chemical dose, exposure duration, and differing values for other exposure variables. These differences constitute a natural variability due to the heterogeneity of people (Burmaster and Appling, 1995:2437). Therefore, there exists

some continuous distribution that represents how each of the random variables is distributed. The distribution represent the range of values a variable can assume and the likelihood that any given value will be found in a population. Ideally, an assessor attempts to characterize these distributions and their parameters. Unfortunately this requires perfect information which is not available, so the analyst must settle for imperfect information which only estimates the distributions.

Some key features such as the central tendency, spread of the values, and the extremes can be estimated for each variable using statistics. The data can be used to develop an empirical distribution or a well known parametric distribution. Parametric distributions are the analyst's best estimate, within some resource constraint, of an unknown distribution. The parametric distribution is used, not because it truly represents the underlying distribution, but because it summarizes the data in a simple mathematical model that is understood by others and when used in place of the true distribution it can provide reasonable results (Hattis and Burmaster, 1994:717). An empirical distribution is used when the data does not fit an established parametric distribution.

3.3.2 Uncertainty The difference between the true distribution and the parametric or empirical distribution used to represent the variable constitutes the error in the model of reality. This error is the uncertainty in the variable and stems from two sources (USEPA, 1992b:14). The first source is uncertainty due to measurement error or an insufficient sample size of the population of the variable (USEPA, 1992b, 14; Hattis and Burmaster, 1994:714). In general this type of uncertainty is reducible by additional information. The more information available to estimate the distribution the less uncertainty there is in the

estimate of the variable and its variability. When a random variable is estimated it is typically the most likely or the expected value that is reported. In the case of human health risk assessment, it is the estimated RME risk value that is used. The second type of uncertainty results from gaps in data that require an analyst to extrapolate the values of interest (USEPA, 1992b:15). Uncertainties resulting from data gaps in dose response assessment were addressed in Section 2.3.2. This type of uncertainty is difficult to quantify because data for humans is very limited in most cases.

The quantification of uncertainty is crucial to the decision process because when it is not quantified, it is difficult to make cost-effective decisions (Elliot, 1992:272). Risk managers are hesitant to proceed to the cleanup phase without gathering as much information as possible to reduce an unknown uncertainty. This has led to risk assessments that take every possible step in the remedial investigation and feasibility study (RI/FS), without considering the VOI, and expend tremendous amounts of resources. If uncertainty could be approximately quantified, then decision analysis tools could be used to make better decisions about gathering additional information or making the decision with the available information.

3.3.3 The Importance of Both Variability and Uncertainty Both variability and uncertainty are critical to the decision maker (Smith, 1994:438). There are different vantage points from which to make decisions. With each level of refined quantification of the estimate of risk, the decision maker is placed in a better vantage point from which to make an optimal decision. An optimal decision is defined as the decision that selects the alternative that yields the highest expected benefit considering the available and attainable

information and the costs (Finkel, 1987:1165). To make use of decision analysis tools to make cost trade-off between gathering more information and taking action, both variability and uncertainty must be identified and better quantified.

3.3.4 Monte Carlo Simulation Method Assuming that estimates of distributions for the variables in the risk equation have been determined, the actual Monte Carlo method can be explained. If all these distributions could be multiplied and divided, or in other words mathematically convoluted to propagate the uncertainty and variability, in accordance with a risk equation, a distribution of the risks could be produced. The high end risks and their associated probabilities could be determined from this distribution. This would provide more information about the range and probabilities of risks and establish a richer context from which to make optimal decisions. If perfect information were available about each of the distributions for each parameter and there was a simple method for convoluting all the distributions, the risk distribution could be determined. Unfortunately perfect information is never available (Haimes, 1993:692) and convoluting a multitude of distributions is extremely difficult (Morgan and Henrion, 1990:183).

An alternative approach is to estimate the distributions and the result of convoluting them through a Monte Carlo simulation. Every variable has associated with it some distribution that defines the range of values and the corresponding likelihood of seeing each value in its population. If random samples of a variable are taken from its estimated distribution, the values with higher probabilities show up more frequently and values with smaller likelihood show up less frequently. If all the distributions for the risk input variables are sampled simultaneously and the samples were used in the risk equation,

the result is one possible outcome on the risk distribution. If the simultaneous sampling is done a large number of times, the values with higher probabilities for all the distributions will occur more frequently, producing more likely risk scenarios, and the values with lower probabilities will occur less frequently, producing less likely risk scenarios. With a large number of samples, an empirical estimate of the frequency distribution of risk is constructed. The more samples available, the better the risk distribution is characterized. With the development of powerful desktop computers these complex simulations have become a feasible task in the field. Instead of subjectively estimating the RME and the high end risk, the laws of probability provide a more scientifically based method to generate an approximation to the entire distribution of risk from which the high end risk is estimated. The quantification and segregation of uncertainty and variability from the empirical risk distribution are also possible and are addressed in Section 3.12.1.

3.4 Decision Analysis

To re-focus it is important to realize that the purpose of this research effort is to aid the decision maker or analyst in allocating limited resources to maximize their return. Decision analysis tools are used to choose how to allocate these resources in a complex risk assessment process. In Section 3.3.4 it is implied that all the distributions in the risk equation must be identified to use the Monte Carlo method. Though all the distributions would be ideal, there are some parameters and their distributions that are more critical to the risk distribution than others. A typical risk assessment may require over 100 variables, but only a few drive the final risk distribution (Burmester and Anderson, 1994:478). If the variables could be identified from most important to least important, a hierarchy could be

established for resource allocation. Every additional variable that is defined as a distribution improves the assessment of the risk distribution, however, the number of variables described as distributions would depend on the relative scope of the assessment and available resources. The resources should be focused on those variables that merit further field investigation. If the most critical variables are represented, then the assessment will capture the most likely characteristics of the risk distribution. It is important to note that the risk would not be underestimated because all variables not described by a distribution would be set at their guideline recommended values or conservative estimates.

3.5 Deterministic Sensitivity Analysis

Traditional sensitivity analysis is used as an initial screening tool to determine which variables are critical to the estimated risk. The results of the sensitivity analysis point the analyst toward certain variables to focus on when gathering information to establish distributions for the initial probabilistic sensitivity analysis. This analysis may be more valuable when there are a significant number of variables used in the risk calculations. This step is optional if some information on the distribution of the variables is available or if the analyst is already comfortable with the selection of influential variables.

To conduct the initial deterministic sensitivity analysis, some initial research was conducted to roughly estimate the possible range of values. Some information for the range of certain variables was found in the literature. Table 3-2 provides information on the possible range for each variable. The reasonable range for exposure frequency (EF) is

derived from the possible number of days in a year. No information was found for the range of the emission factor (K), permeability constant (PC), and the inhalation slope factor for benzene, so the lower bound was established as zero and the upper bound was set at twice their RME value for the sensitivity analysis. These values can be further investigated if they show to be critical to the estimated risk. The range for the mean concentration will be explained in Section 3.7.5. The sensitivity analysis was accomplished in DPL using a conventional tornado diagram and can be seen in Figure 3-1. The vertical line running through the horizontal bars represents the deterministic RME estimate of $2.11E-5$. The one way sensitivity analysis was accomplished by changing each individual parameter over its range while maintaining the other variables at their RME values. The horizontal bars show the range of risk corresponding to the range of each input variable and are arranged with the most influential variable at the top and the least influential at the bottom. The diagram shows which parameters have the most impact on the final estimate of the risk. This type of one way sensitivity analysis has its limitations because it only allows one variable to be tested at a time; therefore, probabilistic sensitivity analysis will be used later in this chapter to account for higher order factors. In conducting a PRA, there is also a concern with the likelihood of values in the range of the outcome and the influence on the shape of the distribution. The assessor now has a place to start gathering more information on the distributions of the critical variables for which information is not currently available.

This type of sensitivity analysis should not be used in place of probabilistic sensitivity analysis, but can be used as an initial step to focus the investigation in the

iterative process. More investigation effort should be given to the more influential variables.

Table 3-2: Initial Estimate of Range of Input Variables

Variable	RME Value	Population and Site Specific	Source
Mean CW	0.1722	0.030-0.170	RI70% Gamma(0.012, 7.608)
Ing_IR (L/day)	1	0.42 -- 3.8	Ershow and Cantor, 1989*
EF (days/year)	250	50 -- 300	Workable Days in Year
ED (years)	25	0.1 -- 65	Israeli and Nelson, 1992*
ET (hours/day)	0.25	0.017 -- 0.333	James and Knuiman, 1987
SA (cm ²)	23000	11000 -- 39000	Phillips and Fares, 1993*
PC (cm/hr)	0.021	0.0 -- 0.042	Reasonable Physical Constraints
Inh_IR (m ³ /hour)	0.6	0.35 -- 0.80	Layton, 1993*
K (m ³ /kg)	0.5	0.0 -- 1	Reasonable Physical Constraints
BW (kg)	70	51.6 -- 114	Brainard and Burmaster, 1992*
AT (days)	25550	Assessment Specific Constant	USEPA, 1989c
SF (kg-day/mg) (Oral)	0.029	0.003 -- 0.063	Thompson <i>et al.</i> , 1992
SF (kg-day/mg) (Inhalation)	0.035	0.0 -- 0.07	No available Range Cited (Twice the Estimated Value)

* -- Summarized by Finley *et al.*, 1994

3.6 Non-site Specific Distributions

It is paramount that a better strategy be devised for determining how to gather data in risk assessments. In 1987 it was estimated that this country spent \$40 billion gathering data in response to environmental regulations and it was forecast to increase to \$55 billion by 2000 (Berthouex, 1994:2). Despite the expenses incurred in the investigation phase there has been a lack of information sharing. Different agencies are known to conduct the same risk assessment on one site for their specific needs without ever referring to information gathered in other assessments (Lawrence, 1993:2963-65). The multiple risk assessments are dictated by regulation, but there is no law forbidding the

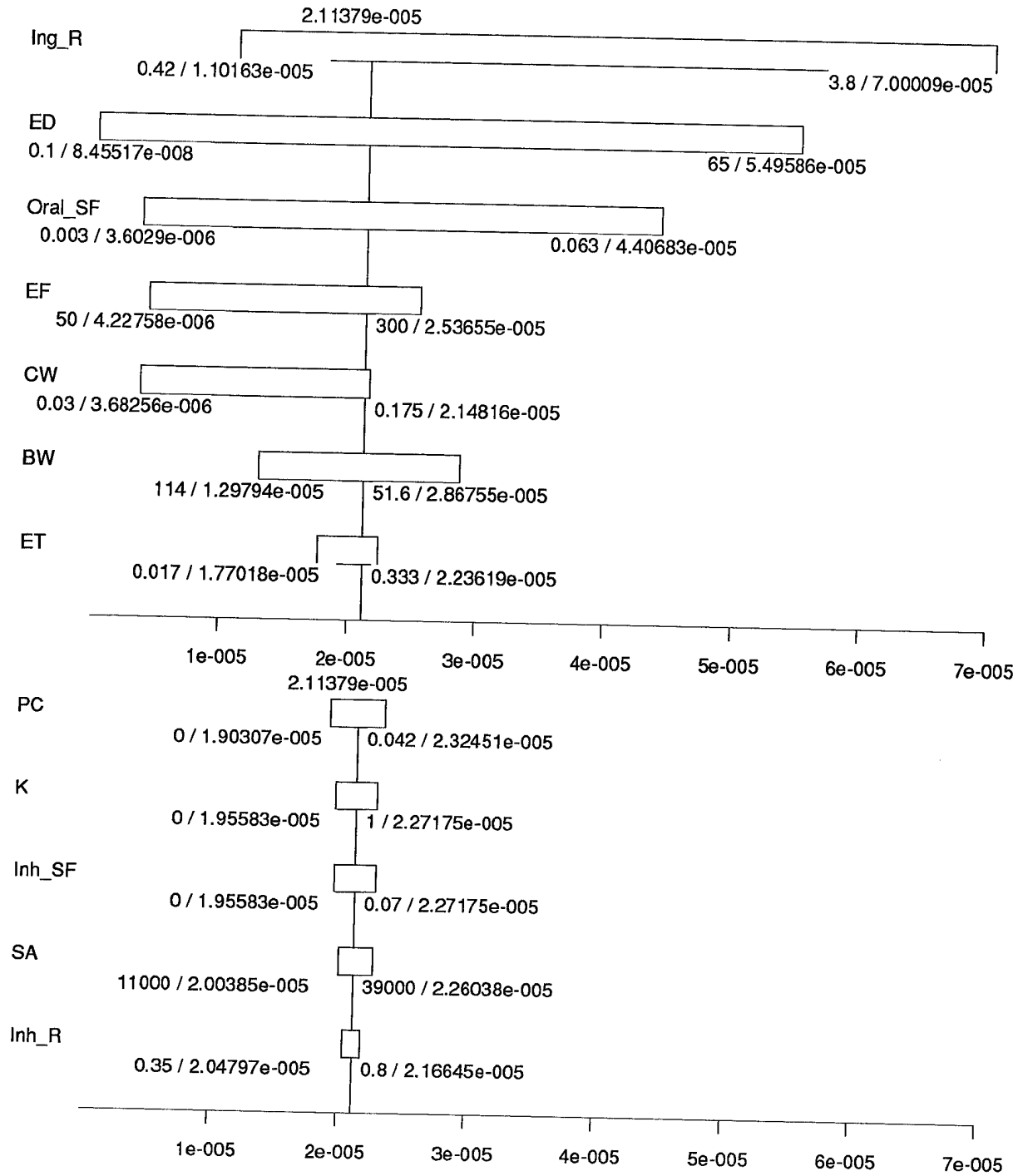

Figure 3-1: Tornado Diagram of RME Point Estimate Risk after RI70%

sharing of information and it should be encouraged. Some efforts such as the EPA's Data Quality Objective program and the Superfund Accelerated Cleanup Model have been implemented to reduce this cost, but efforts fostering efficiency have to continue. A resource that is tapped in this research is the exposure variable distributions that have been established in the literature. Variables such as body weight, skin-surface area, and inhalation rate are independent of the site being assessed and if distributions, developed with sufficient quality and quantity of data, can be established, they can be used by risk assessors to minimize resources expended during the remedial investigation (RI). The criteria for establishing these non-site specific distributions should be stringent, but once established these distributions can provide a resource for many assessments.

Much research and effort has been accomplished to establish and publish distributions in the literature for non-site specific exposure parameters from an abundance of existing data. Some of these distributions have been published and widely accepted as being reasonably representative of the behavior and characteristics of certain populations. By segregating the data and developing separate distributions by age, gender, residence type, or other important descriptors, subpopulations are delineated to allow the appropriate use of these non-site specific distributions. In the spirit of minimizing expenditure, these distributions provide a tremendous amount of information. Seven of the possible thirteen random variables in the risk calculations have been investigated in the literature. These variables include ingestion rate, exposure duration, exposure time, surface area, inhalation rate, body weight, and the oral slope factor. These distributions

are addressed in Section 3.7. Non-site specific distributions cannot be assumed to always be appropriate and it is critical that risk assessors understand the limitations of their use.

Certain criteria should be used to determine whether the data used to develop the distribution are appropriate in quality and quantity to be applied to the general population. Some authors have discussed general criteria for selecting data to fit and publish distribution (Haines *et al.*, 1993), but there were no specific citations of concrete criteria except for a study by Finley *et al.* (1994). Finley *et al.*'s criteria were partially adopted for this research. The criteria for selecting non-site specific distributions in this research are that the distributions are consistent with other studies, have sufficient quality and quantity of data to adequately characterize the extremes of the distribution (Finley *et al.*, 1994:536-37), and that supporting research used to establish the distribution is published in a peer-reviewed journal. To actually use these distributions in a risk assessment (RA), the assessor would coordinate and justify the adequacy of the distributions with the RPM.

3.7 Initial Probabilistic Risk Assessment Input Distributions

An initial probabilistic risk simulation is run with the available information after the remedial investigation 70% (RI70%). The initial simulation is done to determine the sensitivity of the risk distribution to the input distributions and begin prioritizing the variables. The seven non-site specific distributions, mentioned above and noted by an asterisk in Table 3-3, were used in the initial PRA (Finley *et al.*, 1994). Further research was conducted if the variable was found to be critical in the initial probabilistic sensitivity analysis. Each assessment is different and one criterion is established for determining which variables are critical. The uniqueness of each scenario makes the judgment of the

assessor critical to deciding which variables are most important (Haimes *et al.*, 1993:670). This research attempts to objectively guide the judgment of the assessor and assumes that the number of variables that are further researched is dictated by the scope of the assessment and the resources available. Some of the more critical input distributions for OU2 will be discussed and presented individually, in order, according to their priority in the tornado diagram.

3.7.1 Tapwater Ingestion Rate The distribution for the ingestion rate was developed from the summarized percentiles in the study by Finley *et al.* (1994). The percentiles are based on research done by Cantor and Ershow on the results of a 1978 Nationwide Food Survey (1989). The distribution was developed in a similar manner as the ED distribution, in the next section, and can be seen in Figure 3-2.

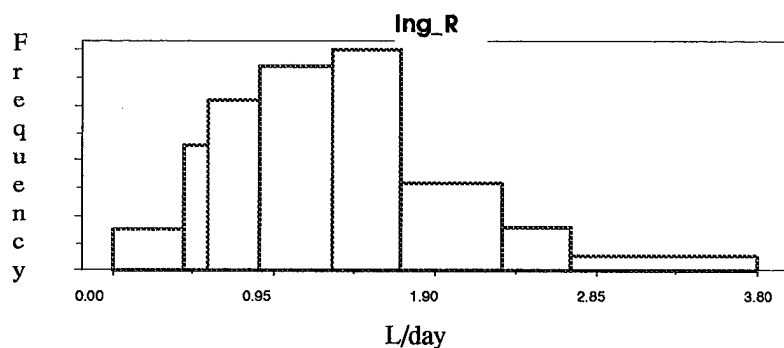

Figure 3-2: Crystal Ball Empirical Frequency Distribution for Tapwater Ingestion (L/day)

3.7.2 Exposure Duration The exposure duration in a RA is often times determined by the residential occupancy period of a particular population. The conservative guideline recommended value is 30 years (USEPA, 1989c:Ch 6, 38). Exposure Duration is considered non-site specific. Realizing the usual importance of the value of this variable and its prolific use in RA, Israeli and Nelson did some research on distribution of

residential occupancy period (Israeli and Nelson, 1992). The research was based on data gathered over a ten year period in a 1985 and 1987 Report by the Bureau of Census and the U.S. Department of Housing and Urban Development. In the study, approximately 94,000,000 occupancies were surveyed to investigate moving patterns of different U.S. household types. The data was broken down into different types of residencies such as renters, owners, farms, all houses and areas such as Mid-West, North-East, South, and West regions so that the distributions could be applied to specific populations. There has been little fluctuation in the U.S. residential mobility rates over the last 40 years and they are not expected to change significantly in the future (Finley *et al.*, 1994:547).

Initially a simple empirical distribution is used for ED because that was the information available at the time the initial probabilistic simulation was run. An empirical distribution is used because, the actual distribution is a complex distribution that is too cumbersome to use in a Monte Carlo simulation. If this distribution or other similar empirical distributions are shown to be critical to the estimated risk, the distribution can be further researched and better approximated in Crystal Ball. The distribution was input into Crystal Ball as an empirical approximation to the density function because that is what the software requires as an input. The empirical probability density function shown in Figure 3-2 was constructed by Crystal Ball using the percentiles for the distributions of 'all-houses' in Table 3-3 (Finley *et al.*, 1994:541). The table shows the percentile of households that will live in a residence for t years or less. Other empirical distributions used in this scenario are developed in a similar manner.

Table 3-2: Selected Distribution Percentiles of Residential Occupancy Period for All Houses

		Percentile (yr)						
All houses	5th	10th	25th	50th	75th	90th	95th	99th
Time	0.1	0.2	0.5	1.4	3.7	12.9	23.1	60.5

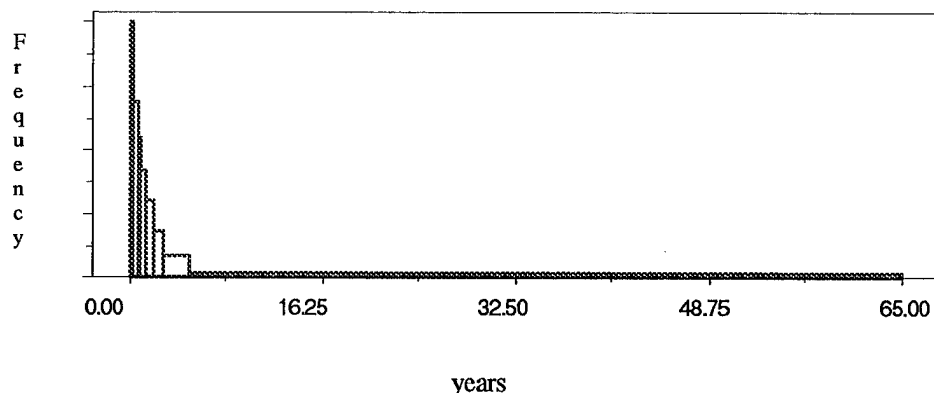

Figure 3-3: Crystal Ball Empirical Frequency Distribution for Exposure Duration

3.7.3 Oral Slope Factor Using the results of earlier publications (Crouch *et al.*, 1981; Crouch, 1981; Crouch and Wilson, 1983) evaluated the carcinogenic potency of 153 chemicals tested by the National Toxicological Program and estimated the degree of conservatism and uncertainty in the EPA's default values (Gaylor *et al.*, 1993:149; Thompson *et al.*, 1992:57). The slope factors (SF), normalized by weight, for each of the chemicals for mice and rats were plotted against each other to determine the correlation between the two slopes. The paired slope factor plot showed clear variation between the dose response of mice and rats to the same normalized exposure dose under the same protocols. To estimate the uncertainty and/or variability in extrapolating a dose response for rats from a dose response for mice based on weight, a regression line was fit to the plot. The standard deviation about the regression line represents the uncertainty and/or variability in extrapolating the dose response from mice to rats (Crouch, 1981:324). The

linear regression line was based on the mean values of the SFs for both species. The estimate of the uncertainty and/or variability in cancer potency factor for the chemicals evaluated was shown to be well represented by a lognormal distribution with a geometric standard deviation of 1.57 about their mean values (Gaylor *et al.*, 1993: 150). This was used by Thompson *et al.*, 1992, as an estimate of the uncertainties that could arise from extrapolating between rodent species and more importantly from rodent SF's to human SF's based on weight or surface area. Based on these results, the distribution representing the uncertainty for benzene has an arithmetic mean of 0.016 (kg-day/mg) and an arithmetic standard deviation of 0.012 (kg-day/mg) and can be seen in Figure 3-3 (Thompson *et al.*, 1992:56). If the cancer slope factor is significantly influential after the deterministic and probabilistic sensitivity analysis then the variable would merit further research.

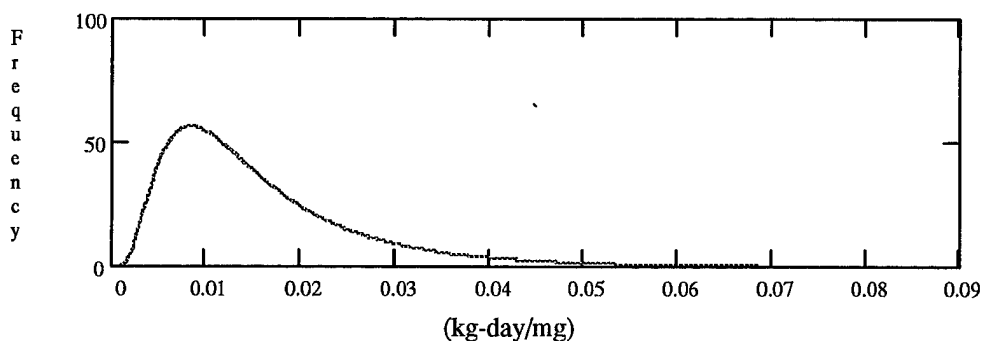

Figure 3-4: Estimated Distribution for Benzene Carcinogenic Slope Factor

3.7.4 Exposure Frequency The exposure frequency is bounded by the number of days in a year. Since this variable was shown in the tornado diagram to be one of the more influential variables it is estimated by a triangular distribution in the initial PRA for sensitivity analysis purposes. The triangular distribution is a conservative distribution that takes into account large amounts of uncertainty (Finley *et al.*, 1994:535). It can be used as an initial estimate when the lower, most likely, and upper values for a variable are

known or estimated. The triangular distribution parameters are a lower bound of 50 days, a mode of 200 days and the upper bound estimate of 300 days. The mode was taken from the actual estimate of the central tendency value from the risk assessment. The upper bound was set above the RME value of 250 days, but still within a reasonable upper bound estimate of the workable days in a year. The lower bound was subjectively estimated as a reasonable estimate. This distribution can be further investigated if it is shown to be critical.

3.7.5 Mean Concentration Distribution The first assumption evaluated from Clairmont's model was the simplifying assumption, discussed in section 2.6.2.1, used to estimate the distribution of the mean concentration. Devore states that at a sample size, $n > 30$ an analyst can confidently assume the CLT applies and that the distribution of mean for any variable is approximately normally distributed regardless of the variable's distribution (Devore, 1995:232). Others claim that if the population distribution is highly skewed that n may need to be as high as 50 before the CLT applies (Gilbert, 1987:140). Many researchers have reported that environmental pollutants have distributions that are highly skewed and approximated by lognormal distributions (Berthouex, 1994:41; Ott, 1990:1378; Gilbert, 1987:164; and Burmaster and Edelman, 1996:4; USEPA, 1992c:4). To use the normal probability distribution as an effective approximation of \bar{X} requires large sample sizes for distributions that are skewed (Chen, 1995:189).

The mean concentration has a lower bound of zero, which is uncharacteristic of the normal distribution, and often the lower bound is one or two standard deviations away from the mean, instead of four or five as for a normal distribution. Also, using a normal

distribution results in negative mean concentrations and negative risks that are unrealistic (Haimes, 1993: 683). Nowhere in the literature was there found a procedure for estimating a more appropriate estimate of the uncertainty in the sample mean concentration with small samples sizes for highly skewed distributions; thus an alternative method was developed to estimate the mean concentration distribution.

3.7.5.1 A More Appropriate Distribution for the Mean Concentration Actual data from the risk assessment at Operable Unit 2 (OU2) for benzene concentration in groundwater was used. OU2 covered a large geographical area so to assess the risk the operable unit was divided into smaller areas. The area within OU2, that is evaluated in the following analysis is the petroleum, oil, and lubricants (POL) storage area within OU2. The data collected during the site investigation is excluded from the analysis because it was collected across all of OU2 and may not correspond specifically to the POL storage area.

An initial fourteen samples from the RI at the POL storage area are used to estimate the distribution of the pollutant concentration distribution. The 14 samples represents 70% of the data collected at the RI70%. Using ExpertFit, an optimization curve fitting program, the best fit distribution was fit to the histogram of the data (Averill M. Law & Associates, 1995). This distribution represents the best estimate of the actual benzene concentration distribution (ARI70%) with the information available after the RI70%. The ExpertFit tested 20 distributions and the results for the top distributions can be seen in Appendix G. The graph of the best fit Gamma distribution overlaid on the histogram of the 14 samples is shown in Figure 3-5. The gamma distribution is a versatile

distribution that can have many of the same characteristics as a lognormal distribution. The parameters, from ExpertFit, for the Gamma distribution are scale parameter (β), which is equal to 0.17347, and the shape parameter (α), which is equal to 0.53241.

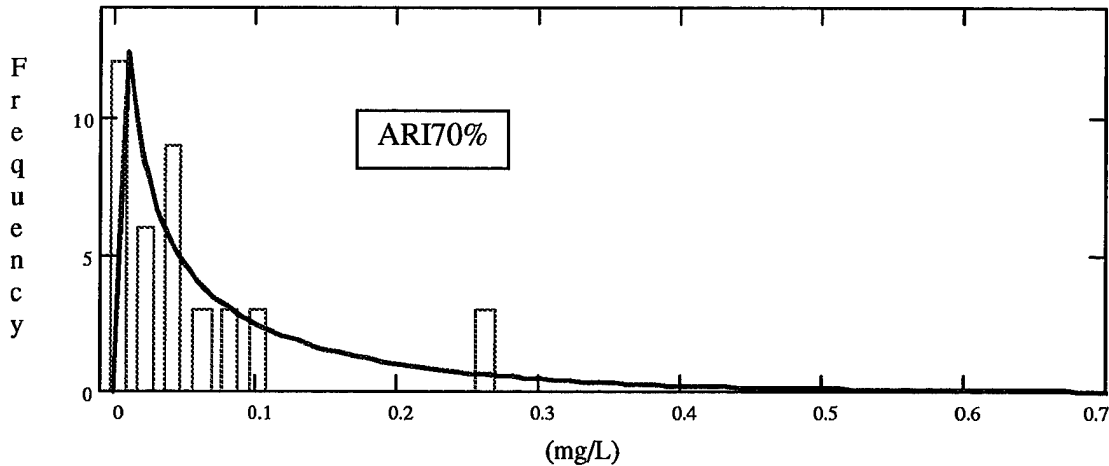

Figure 3-5: Best Fit Gamma Distribution for Benzene in Groundwater

The fourteen samples for benzene resulted in a mean concentration of 0.092 (mg/L). This is an estimate of the mean concentration for benzene, but there is a significant amount of uncertainty in the estimate because only 14 samples are available. The sample set available represent one set of 14 samples that could have resulted from sampling the distribution for benzene. A program written in Mathcad 6.0 Plus (MathSoft, 1995) was used to generate 1000 14-sample set vectors to represent a possible range of 14 sample sets that could result from the ARI70% distribution for benzene. Using the 1000 vectors, 1000 means were calculated to estimate the uncertainty in the mean concentration. Once again, ExpertFit was used to estimate the best fit distribution of the 1000 means. The best fit distribution of the 1000 means represents an estimate of the uncertainty in the mean concentration distribution (MRI70%) with 14 samples from

ARI70%. The best fit distribution was a Gamma distribution with parameters $\beta = 0.01214$ and $\alpha = 7.60837$. The ExpertFit results for the top distributions can be seen in Appendix B. Figure 3-6 shows the histogram of the 1000 means, the best fit Gamma distribution, and the normal distribution that would result from using the CLT simplifying assumption. The normal distribution has a mean of 0.092 (mg/L) and a standard deviation of 0.037 (mg/L) which is the standard deviation of the 14 samples divided by the square root of 14. The normal distribution is provided to compare it to the simulated mean concentration distribution.

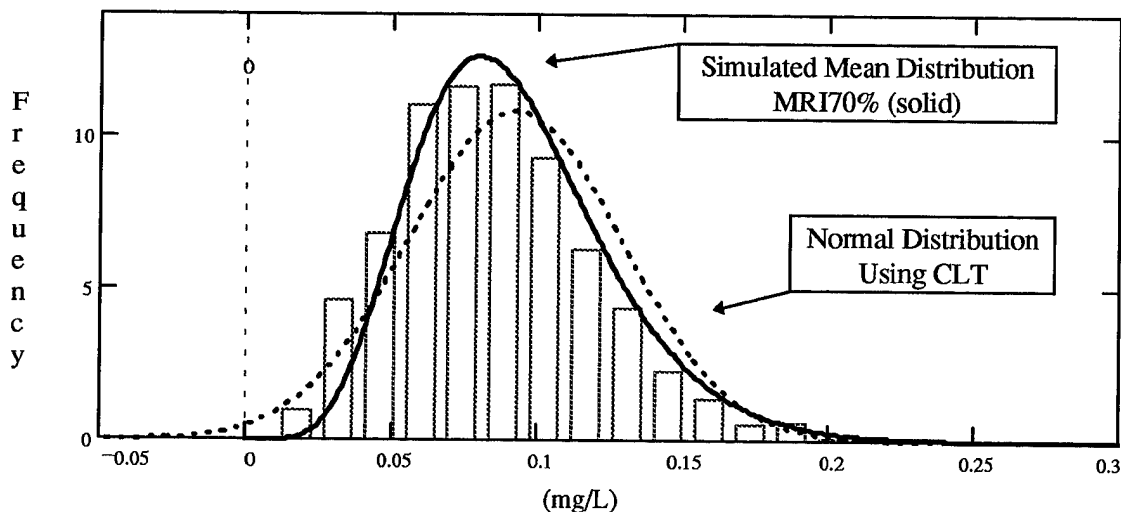

Figure 3-6: Best Fit Simulated Mean Concentration Distribution vs Normal Distribution

The graph shows how the Normal distribution does not adequately represent the estimate of the frequency distribution of the data. The physical constrain of 0 is also shown on the graph to highlight the fact that the Normal distribution contains unrealistic values that are less than 0. The best fit Gamma distribution is a more appropriate estimate of the uncertainty in the mean concentration distribution.

Some authors argue that environmental data is usually spatially and serially correlated, which results in an underestimation of the true variability of the contamination at a site (Banks, 1996:442). There is also an argument that standard statistical techniques used on a single data set reveal only a trivial portion of the uncertainty in the parameters being estimated (Hattis and Burmaster, 1994:726). These are both valid arguments, but they must be considered in light of how important the estimate of the variance of the mean concentration is to the overall risk distribution. Appendix C shows some sensitivity analysis of the estimate of mean and variance for the mean concentration distribution that will show that as long as the sampling plan makes an attempt to randomize the sampling, the effects of spatial and serial correlation and small sample sizes should not significantly effect the estimate of the risk distribution.

3.7.6 Body Weight Body weight is probably the most well known of the common input variable. This physiological characteristic has been studied extensively in human health risk assessment and other disciplines. There is sufficient data to develop well fitted age and gender specific distribution for the weight of individuals. The distribution used in this research was developed by Brainard and Burmaster and has gained acceptance in the field (1992). Unless the population under study is very much different from the general population, these fitted distributions can be appropriate. The distribution for men above the age of 18 was used. The fitted distribution is a normal distribution with a mean of 78.7 kg and a standard deviation of 13.5 kg and is shown in Figure 3-6.

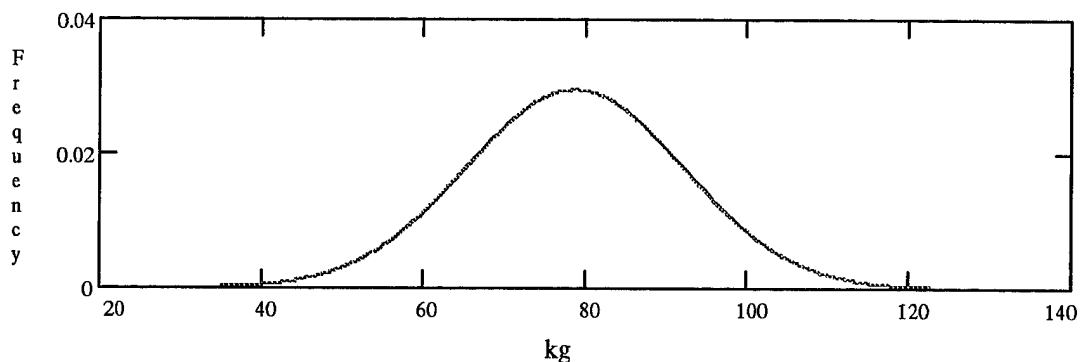

Figure 3-7: Distribution of Weight for Men Older Than 18 years of Age

3.7.7 Exposure Time The exposure time is used in the inhalation route and is dependent on amount of time a person spends in the shower. The results of a study done by James and Knuiman in 1987 of the shower duration for 2500 households was found in the EPA's ExposureFactors Handbook (USEPA, 1989c:Ch 5, 35). If the distribution proves to be critical further investigation could be conducted. The distribution was developed in a similar manner as for the ED and can be seen in Figure 3-8.

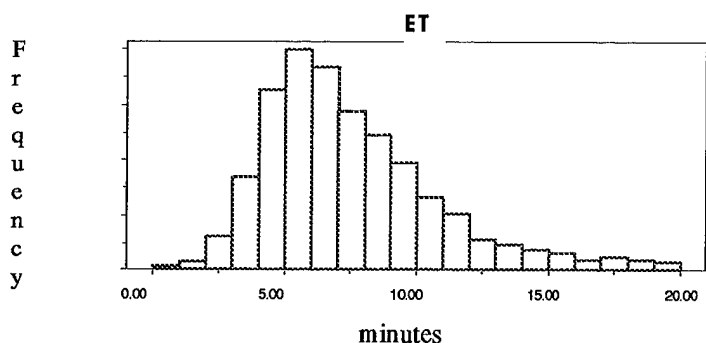

Figure 3-8: Crystal Ball Empirical Frequency Distribution for Exposure Time

3.7.8 Surface Area to Body Weight Ratio Because the surface area of the body is dependent on body weight, a distribution for the ratio of SA to BW is used in the simulation. The value of body weight sampled is multiplied by the sampled SA:BW ratio to estimate an appropriate SA. The specific distributions for BW and the SA:BW ratio are

both for men older than 18 years to ensure that the simulated BWs and SA's are reasonably matched. The fitted distribution for SA:BW ratio was shown by Phillips *et al.* (1993) to be represented by a normal distribution with a mean of 284 cm²/kg with a standard deviation of 28 cm²/kg and can be seen in Figure 3-7.

3.7.9 Inhalation Rate The distribution for the inhalation rate was developed from the summarized percentiles in the study by Finley *et al.* (1994). The percentiles are based on the research of Layton on chronic inhalation rates (1993). The distribution was developed in a similar manner as the ED distribution and can be seen in Figure 3-10.

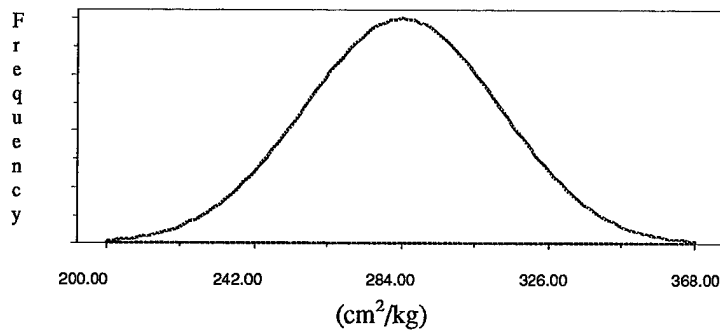

Figure 3-9: Surface Area to Body Weight Ratio for Men Older than 18 years

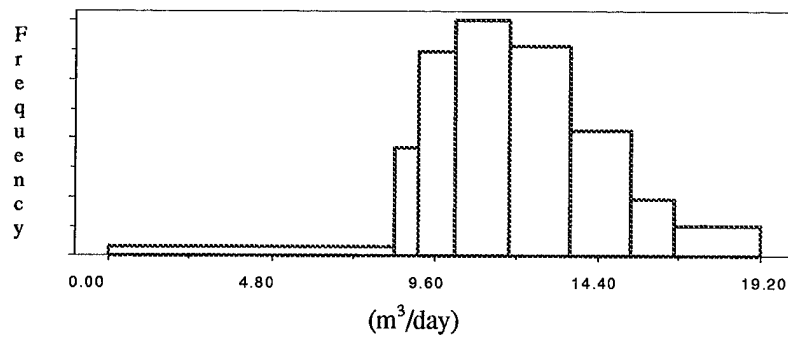

Figure 3-10: Crystal Ball Empirical Frequency Distribution of Inhalation Rate for Men Between 18 and 30 years of Age

No information was found in the literature for the permeability constant (PC), emission factor (K), or the inhalation slope factor. Based on the results of the

deterministic sensitivity analysis, it was assumed that even if the distributions for these values were known, they would contribute little to the overall risk because the inhalation route contributes only 7.4% of the total risk. These values were set at their conservative RME values to ensure the risk was not underestimated. The focus was placed on those variables that were more significant (Haines *et al.*, 1993:682). The distributions for surface area and inhalation rate were used because they were available.

3.8 Initial Probabilistic Risk Assessment

The initial PRA was developed using the deterministic spreadsheet for the example risk calculations. Clairmont's estimated risk distribution was simulated first to compare it to the results of the PRA. The calculations were done exactly like those in Table 3-1 except that the mean chemical concentration was assumed to have a normal distribution with a mean of 0.092 mg/L and a standard error of 0.037 mg/L. In running the simulation the number of random samples taken from the assumed distributions is vitally important to the confidence in the results. It is recommended that at least 10,000 trials be used to gain confidence in the results (Burmester and Anderson, 1994:480). With a sample size of 10,000 the assessor can be more than 95% confident that any selected percentile above the 90th percentile is between the estimates for its two neighboring percentiles (Morgan and Henrion, 1990:202). For example, with 10,000 samples the 94th and 96th percentiles are at least a 95% confidence interval for the 95th percentile. This confidence holds regardless of the shape of the final estimated distribution (Morgan and Henrion, 1990:202). The results of the simulation of Clairmont's model can be seen in Figure 3-11. The CA and CUA values, the RME point estimate (RME PE) are marked, and percentiles

are shown in Figure 3-11 to give the reader a perspective of the simulation results. The CA level established for the Operable Unit 2 was $5 \cdot 10^{-7}$ (a unitless probability of an individual developing cancer [USEPA, 1989c:Ch 8, 11]) and the CUA level was set at $5 \cdot 10^{-5}$ (unitless) by the decision maker.

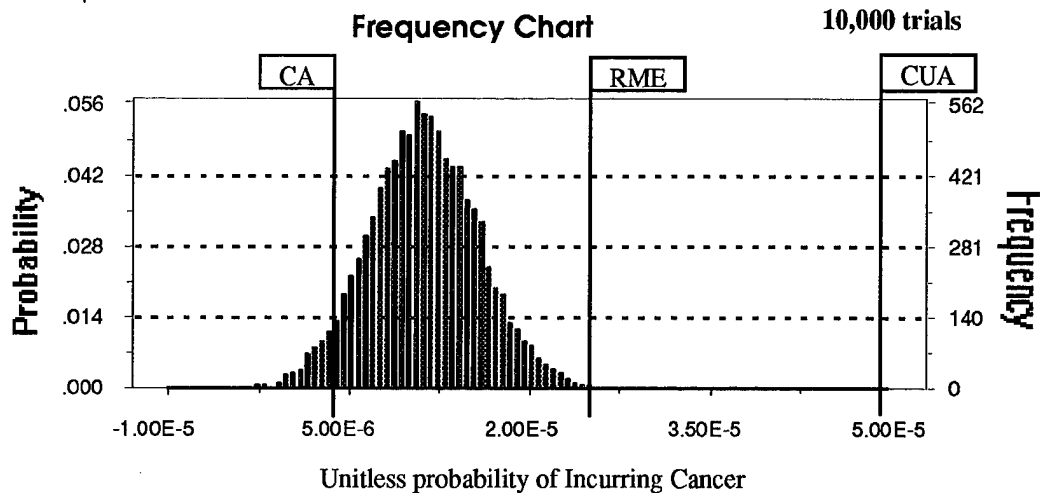

Range and Percentiles

Min	10%	20%	30%	40%	50%	60%	70%	80%	90%	Max
-7.59E-6	5.54E-6	7.54E-6	8.95E-6	1.02E-5	1.13E-5	1.24E-5	1.37E-5	1.51E-5	1.89E-5	2.84E-5

Figure 3-11: Results of Simulation of Clairmont’s Initial Model

The initial PRA was done in much the same manner except that all the input distributions described in Section 3.7 were used. The simulation was also run for 10,000 trials and the results of the initial risk distribution at the RI70% can be seen in Figure 3-12. Because the risk distribution is very skewed, it difficult to show all the information on a single graph, therefore, two graphs are used to represent the results. The first panel shows the histogram of risk values from zero to the CUA level of $5 \cdot 10^{-7}$ (unitless), which encompasses 99.51% of the values. The second panel zooms in on the range of values

from zero to the CA level $5 \cdot 10^{-7}$ (unitless) of risk. The graphs and corresponding percentiles provide much more information about the possible variability in the risk to a naturally variant population than does the point estimate of Section 3.3.2. The graphs are good for visual presentation of the results, but are inadequate for accurately estimating the distribution percentiles or comparing the graphs. The percentiles of the distributions can be calculated from the cumulative frequency count. Key percentiles and statistics in Tables 3-6 and 3-7 are used to more accurately compare the two distributions.

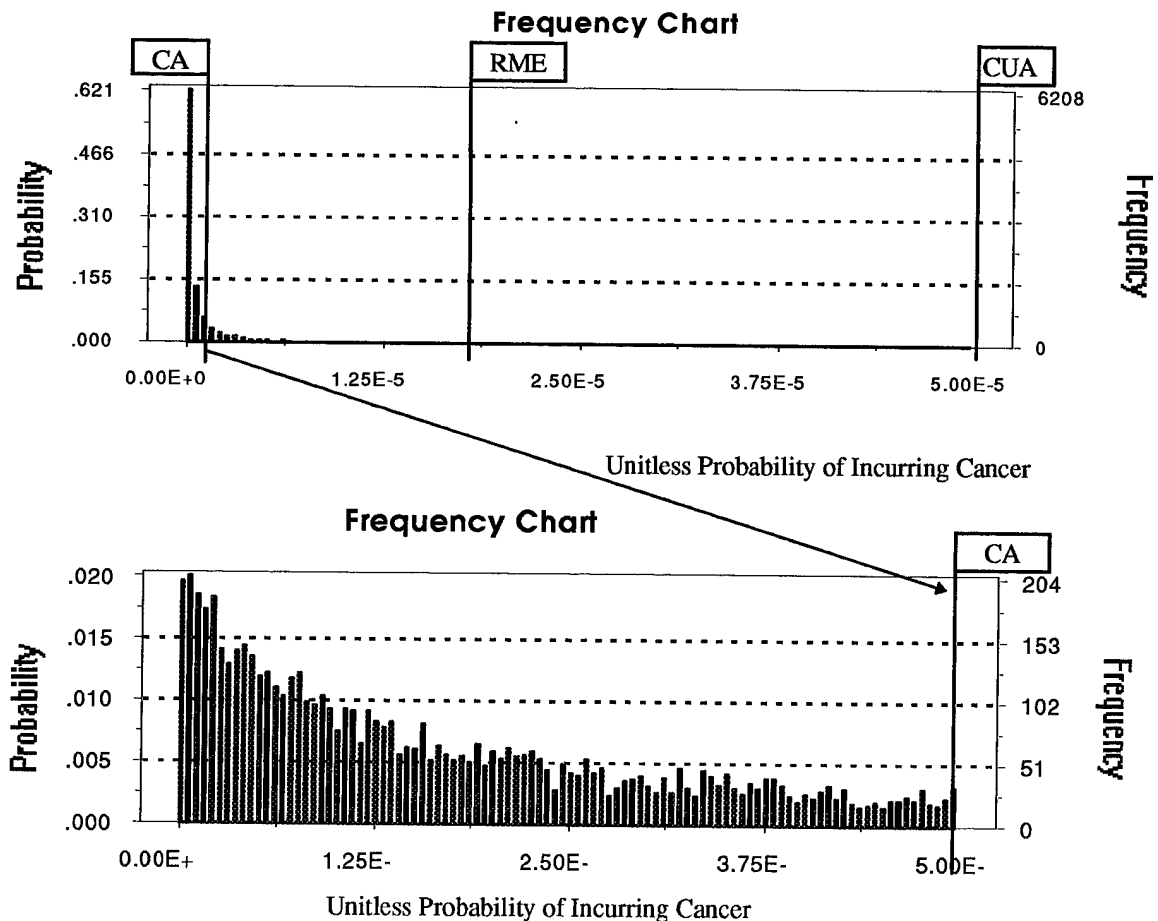

Range and Percentiles

Min	10%	20%	30%	40%	50%	60%	70%	80%	90%	Max
8.37E-11	1.25E-8	6.44E-8	1.13E-7	1.87E-7	2.90E-7	4.56E-7	7.34E-7	1.32E-6	3.19E-6	9.85E-5

Figure 3-12: Results of Initial RI70% Risk Distribution

The probabilistic risk simulation significantly transformed the risk distribution. It produced a highly skewed distribution as observed by others in the literature (Finley and Paustenbach, 1994; Smith, 1994). The estimate of the risk distribution using Clairmont's method also resulted in risks less than zero which are considered unrealistic (Haines *et al.*, 1993:683). The major difference is how the risk probabilities are altered as shown in Table 3-7. For the initial RI70% risk distribution, the probabilities of the risk being high, medium, and low were 0.6208, 0.3669, and 0.0123, which indicates a significant differences in the assessed risk probabilities when more variables are considered as stochastic. The initial simulation provides another phase in the iterative process of prioritizing and selecting variables that are worthy of further investigation. Probabilistic sensitivity analysis can provide better insight into what variables are most important to determine the allocation of resources.

Table 3-4: Selected Percentiles From Initial RI70% Risk Distribution

Percentiles	50%	60%	70%	80%	90%	95%	Max Value
IM	1.13E-5	1.24E-5	1.37E-5	1.51E-5	1.71E-5	1.89E-5	2.84E-5
RI70%	2.9E-7	4.56E-7	7.34E-7	1.32E-6	3.19E-6	6.57E-6	9.85E-5

IM -- Initial Model (Clairmont, 1995)

RI70% -- Initial Probabilistic Risk Distribution After RI70%

Table 3-5: Key Statistics from Initial RI70% Risk Distribution

Simulation	Percentiles			Risk Probabilities		
	CA	CUA	RME PE*	Low	Med	High
IM	7.97%	100%	99.61	0.0797	0.9203	0.0000
RI70%	62.08	98.77	98.04	0.6208	0.3669	0.0123

*-- Reasonable Maximum Exposure Risk Point Estimate

3.9 Initial Probabilistic Sensitivity Analysis

Traditional sensitivity is good for determining how the range of the output risk changes as range of the input variable changes. In addition there is a vested interested in the strength of the sensitivity to an assumed distribution and the effect on the shape of the risk distribution. The strength of the influence of an assumed distribution is important to evaluate the relative importance of one variable to another. It is also important to estimate the influence of input distribution on the shape of the risk distribution, which is vital because it can significantly effect the risk probabilities. For an analyst, this sense of influence is important for committing limited resources. Probabilistic sensitivity analysis (PSA) is relatively new, and common and approved techniques for accomplishing PSA have not been established. Publications that offer discussions about PSA differ in how they accomplish this analysis because there are different reasons for doing PSA (McKone, 1993; Burmaster and von Stackelberg, 1991). This section presents a method for determining the strength of the variable's influence on the values of the risk distribution and how the shape of the risk distribution is effected by the presence of an assumed distribution.

3.9.1 Probabilistic Sensitivity Analysis on Strength of Effect Simple, single variable sensitivity analysis was done in Section 3.5, but more valuable sensitivity analysis can be conducted to account for multi-variable dynamics to estimate the strength of influence of each assumed distribution. The Spearman rank correlation coefficient between every random variable that is input as a distribution and the calculated risk was used as a measure of the strength of effect an assumed distribution has on the final distribution

(Decisioneering, 1993:162). The coefficient is a relative value that ranges from minus one to positive one. The magnitude of the absolute value of the coefficient gives an indication of the degree to which the input variable and the calculated risk change together. The sign of the coefficient indicates whether the relationship is positive or negative. A large positive correlation coefficient suggests that large values of the variable are associated with large values of risk and small values of the variable are associated with small values of risk. A negative coefficient indicates that small values of the variable are associated with large values of risk and large values of the variable are associated with small values of risk. The coefficient provides a meaningful measure to determine the importance of a variable in determining the estimated risk distribution in the simulation.

Sensitivity Chart

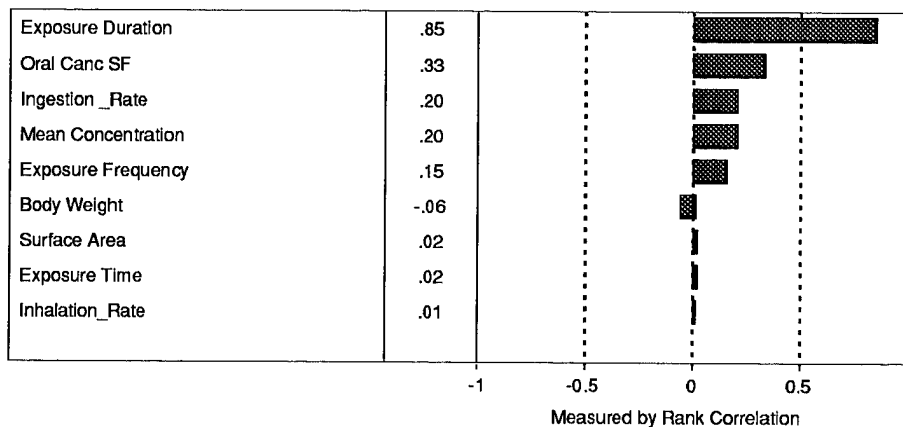

Figure 3-13: Probabilistic Sensitivity Analysis Results of Initial RI70%

The sensitivity analysis was run with the distributions mentioned in Section 3.7 and the results can be seen in Figure 3.13. The variables are ranked from most important to least important so the variables can be easily prioritized. One limitation of this initial

analysis is that it does not include a distributions PC, K, or the inhalation SF. From the results of the deterministic sensitivity analysis it is assumed that the influence of these variables would be outweighed by the influence of the other more important variables (Haimes *et al.*, 1993:682). When information was not available on the distribution of a variable, this analysis relied on the conservative estimated values to at least ensure that the risk was not underestimated

Figure 3-15 shows that the exposure duration, oral slope factor, ingestion rate, mean concentration, and exposure frequency have a significantly greater impact on the calculated risk than the other variables. Inaccurately assessing these variables would result in greater error than inaccurately assessing the other variables. Thus, available resources should be allocated to reduce the uncertainty in the critical variables first in the order indicated by Figure 3-13.

3.9.2 Probabilistic Sensitivity Analysis on Shape of Risk Distribution Once a simulation has been run, variables represented by distributions can be temporarily represented by their RME constant value for the purposes of visualizing the effects of input distributions on the final forecast distribution. This procedure is termed freezing the distribution because the random variable is momentarily assumed to be a constant. Some distributions may be more important than others in determining the shape of the final risk distribution and it would be beneficial to know which ones they are. Four 10,000 trial simulations were run while freezing the assumed distribution for the four most influential variables in the initial probabilistic sensitivity analysis and the results can be seen in the graphs in Figure 3-14.

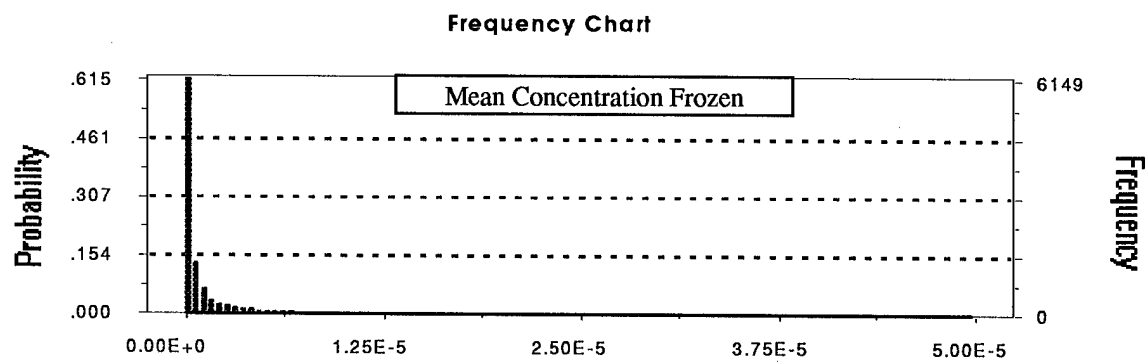
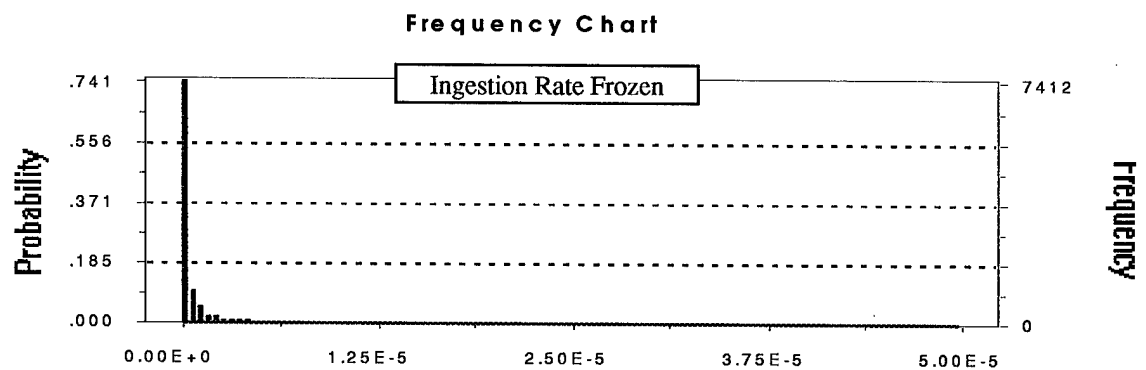
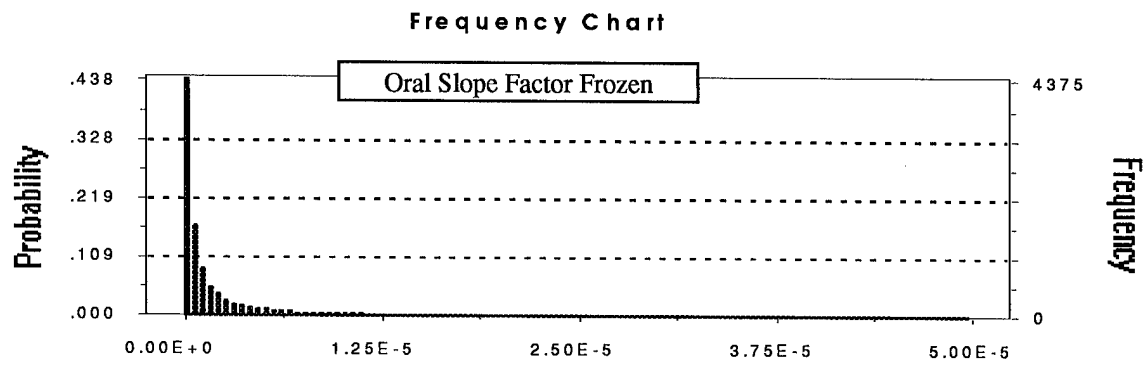
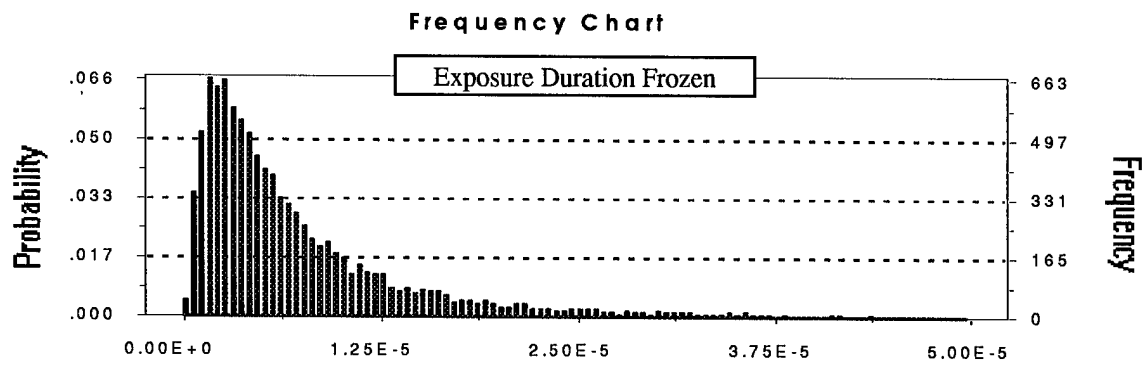

Figure 3-14: Results of Probabilistic Sensitivity Analysis on Shape of Risk Distribution

Figure 3-14 provides a good visual aid for observing the effects of the input distributions on the shape of the risk distribution. The key finding is that the assumed exposure duration distribution is the only variable that is critical to the shape of the risk distribution. It is the only distribution that significantly changes the shape of the highly skewed risk distribution. Without the exposure duration distribution, the risk distribution is skewed but still bell-shaped. Each graph has the same scale so it is easy to compare the graphs. The other variables were not evaluated because it is assumed that they would have less influence on the shape of the risk distribution than the CW.

Based on these results and the results of Section 3.9.1 the exposure duration, oral slope factor, ingestion rate, mean concentration, and the exposure frequency were the only variables whose distributions were further investigated. The other distributions have only minor effects that improve the assessment but are not critical to the most likely risk distribution. Variable distributions having a less significant influence on the risk distribution can be further investigated after the more important variables have been further characterized.

3.10 Considerations for Further Field Investigation

There are certain criteria to consider when conducting further investigation of variables. The distributions representing the variables consist of variability and two possible types of uncertainty, which were discussed in Section 3.3.2. If an abundance of data exists, the distributions often consist primarily of variability, and additional information may only marginally reduce the natural variability. Some variables such as the slope factor or reference dose have inherent uncertainty due to extrapolation that cannot

be significantly reduced by additional information. Additional information should be gathered only if the uncertainty can be reduced, the distribution is critical to the assessed risk, and the reduced uncertainty is beneficial in terms of potentially changing the decision strategy (Haines *et al.*, 1993:682). The analyst must be aware of these criteria when deciding what information to gather. Each of the five most critical distributions will be addressed to determine if and how they should be improved to obtain more accurate estimates of the risk distribution and for uncertainty analysis.

3.10.1 Exposure Duration To more accurately represent the distribution of exposure duration the original published research, which was not available at the time of the initial PRA, was referenced. The cumulative data was fit by a nonlinear regression curve to calculate the probabilities for residential occupancy of t years or more. Because the sample of homes was so large, the curve used to estimate the distribution of residential occupation is assumed to consist primarily of interpersonal variability and little uncertainty (Finley *et al.*, 1994:548). There would be little benefit from gathering additional information on the exposure duration, unless the population was very distinct from the typical U.S. population.

The actual ED equation is cumbersome to use in a Monte Carlo simulation so a more refined empirical distribution was used to represent the distribution for ED. The distribution was reconstructed in Crystal Ball with a higher resolution than the distribution in the initial PRA.

3.10.2 Oral Slope Factor Since the distribution of the slope factor showed to be very influential in the initial sensitivity analysis, it was further investigated. The estimate of the

uncertainty in extrapolating human toxicity values from rodent toxicity data, in Section 3.7.3, based on the study by Crouch (1983), was established from uncertainties from interspecies extrapolations between mice and rats. Others suggest that to estimate the uncertainties of extrapolating human toxicity values from rodent toxicity values, some human data is necessary (Allen *et al.*, 1988; Baird *et al.*, 1996). The difficulty in quantifying the uncertainties is the insufficient amount of human data, but there are some chemicals for which there does exist sufficient epidemiological data to estimate human toxicity values.

In a study by Allen *et al.* (1988) 23 chemicals, for which there is sufficient human and animal data to quantify a carcinogenic potency, were evaluated to determine the correlation between the toxicity values of animals and humans. This was done in a similar format of comparing the SFs of Animals to the SFs of humans and analyzing the correlation between the two for each chemical. The study followed a methodology similar to the study by Crouch (1983) discussed in Section 3.7.3. For a more thorough discussion of the methodology and results the reader is encouraged to read Allen *et al.*, 1988 and Gaylor *et al.*, 1993. Benzene was one of the chemicals included in the study. In a further evaluation of Allen *et al.*'s study, Gaylor *et al.* (1993) found that the uncertainty and or variability in the extrapolation of cancer potency factors for humans based on animal data was well represented by a lognormal distribution with a geometric standard deviation of 2.35 about the mean toxicity value of the chemical evaluated by Allen *et al.* This distribution represents an estimate of the variability and uncertainty in human toxicity values based on animal data.

The distribution for the uncertainty and variability in the cancer slope factor for benzene, based on these studies, is shown in Figure 3-16. It has an arithmetic mean of 0.016 and an arithmetic standard deviation of 1.491. Allen *et al.*'s distribution has a significantly higher variability than the distribution defined by Crouch and Wilson in Section 3.7.3, but is consistent with the findings of others. Baird *et al.* (1996) has reported that the uncertainties in noncarcinogenic toxicity values extrapolated between species are larger as the difference between interspecies size increases, which would support the findings of Allen *et al.* Gaylor *et al.* make the same argument in justifying Allen *et al.*'s increased variability in the uncertainty of extrapolating toxicity values (1993: 152). There is still a considerable amount of research required to better estimate the uncertainty and variability of extrapolating toxicity value for humans from animal data. This distribution was used as an estimate of the uncertainty in the cancer slope factor for benzene.

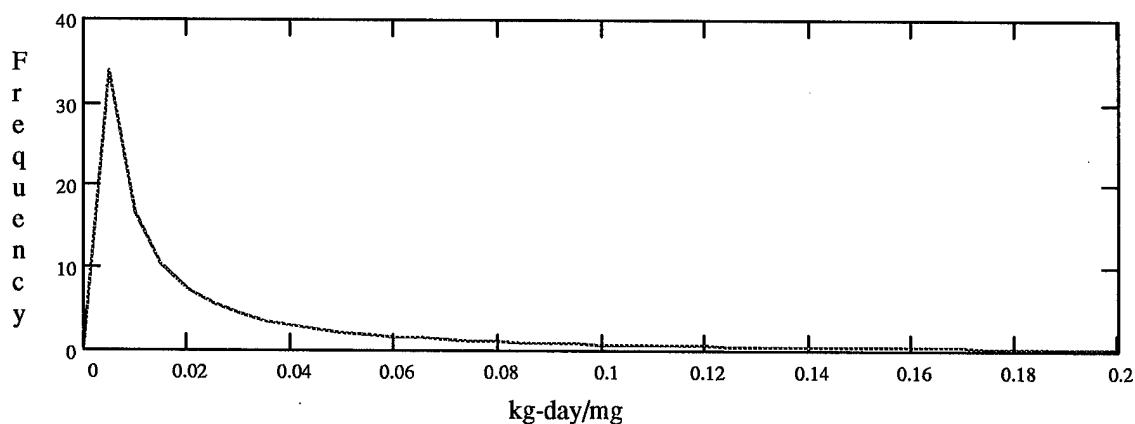

Figure 3-15: Final Estimate of Uncertainty in Human Toxicity Value of Benzene based on Animal Data

3.10.3 Tapwater Ingestion Rate Since the distribution proved to be significant and it was a non-site specific distribution, it was further researched in the literature. Ershow and

Cantor established an empirical distribution for tapwater ingestion from the data collected. Rosenberry and Burmaster used the same data and fit a distribution to the data (1992).

With a sample size of

26,081 people, the results of the research suggested that tapwater ingestion distribution is based more on interpersonal variability in preferences for water than uncertainty. A lognormal distribution with a mean of 2.086 L/day and a standard deviation of 0.869 L/day fitted for the general population between the ages of 20 and 65 is used (Rosenberry and Burmaster, 1993:102). This distribution is used as the improved distribution for tapwater ingestion in the simulation. The risk assessor would not benefit from gathering information on tapwater ingestion unless the exposure population differed significantly from the general U.S. population.

3.10.4 Mean Concentration Distribution With 14 samples from the RI70%, there is a significant amount of uncertainty associated with the estimate of the mean concentration distribution. The only way to reduce the uncertainty in the mean concentration is to gather more samples in subsequent phases of the investigation. An analyst must evaluate the importance of the estimate of the mean concentration distribution relative to other variables. This is done in the uncertainty analysis of Section 3.12.1. The exposure duration is approximately four times more influential and the slope factor is one and half times as influential as the mean concentration. In light of the significantly strong influence of these two variables, the exact value of the mean and standard deviation mean concentration may not be as critical to the risk distribution. The analysis done in Appendix B and section 3.11 will further demonstrate this point.

3.10.5 Exposure Frequency The exposure frequency distribution was the only site specific distribution that proved to be significant. Since the exposure population is a future population of commercial workers it is difficult to sample the actual population. If the anticipated type of future operations for the site were known, then an operation of similar type could be sampled to attain a better estimate of the distribution. Since this is a retrospective study and the site has been completely assessed no further information was gathered on exposure frequency. The distribution for exposure frequency was not improved for the PRA simulation. In an actual site assessment this variable may prove to be critical, but the assessor must evaluate the variable for its contribution to variance as shown in Section 3.11. If other site specific variables or non-site specific variables, not found in the literature, show to be significantly influential variables, they should be evaluated for further field investigation using the criteria in Section 3.10 and 3.12.1.

3.11 Final RI70% Risk Distribution

After improving the input distributions discussed in section 3.10, the simulation was run with the available information after the RI70%. The simulation was run for 10,000 trials, and the results can be seen in Figure 3-16. The first panel shows the histogram of risks from zero to the CUA level of $5 \cdot 10^{-5}$ (unitless), which encompasses 99.51% of the values. The second panel zooms in on the range of values from zero to the CA level of $5 \cdot 10^{-7}$ (unitless) of risk. For a more detailed analysis of the risk distribution, the percentiles in Figure 3-16 and the key statistics in Table 3-10 are provided. The simulation results provide much more information than the RME point estimate.

Table 3-6: Key Statistics from PRA Simulation after RI70%

Simulation	Percentiles			Risk Probabilities		
	CA	CUA	RME PE	Low	Med	High
RI70%	90.46%	99.51%	99.32%	0.9046	0.0905	0.0049

The distribution allows the decision maker to estimate the likelihood of the RME point estimate and any other risk to make decisions that are appropriate for the given site (Smith, 1994:438). The decision maker can now analyze the distribution of risks and make decisions based on all the available information instead of single point estimate, accompanied by discussion of possible uncertainties, that is provided by the deterministic point estimate approach.

3.12 The Need for Uncertainty Analysis of the Risk Distribution

The second key area of review of the Clairmont's model was the uncertainty analysis of the risk distribution. Sensitivity analysis is used to evaluate the effect of uncertainty in each variable on the decision strategy. Clairmont's model did not conduct sensitivity analysis of the assessed risk distribution. Sensitivity analysis of the risk distribution is important if the decision maker is going to accept the recommendations of the model. Clairmont's representation of the risk distribution is an accurate portrayal if only the mean concentration is considered a stochastic variable. Others have demonstrated that as the number of variables represented as distributions increases, the risk distribution becomes less Gaussian in shape and becomes increasingly more skewed (USEPA, 1992b:22921; Burmaster and von Stackelberg, 1989:95). A more appropriately assessed risk distribution, including uncertainty and variability analysis, will lend credibility to the decision support model recommendations.

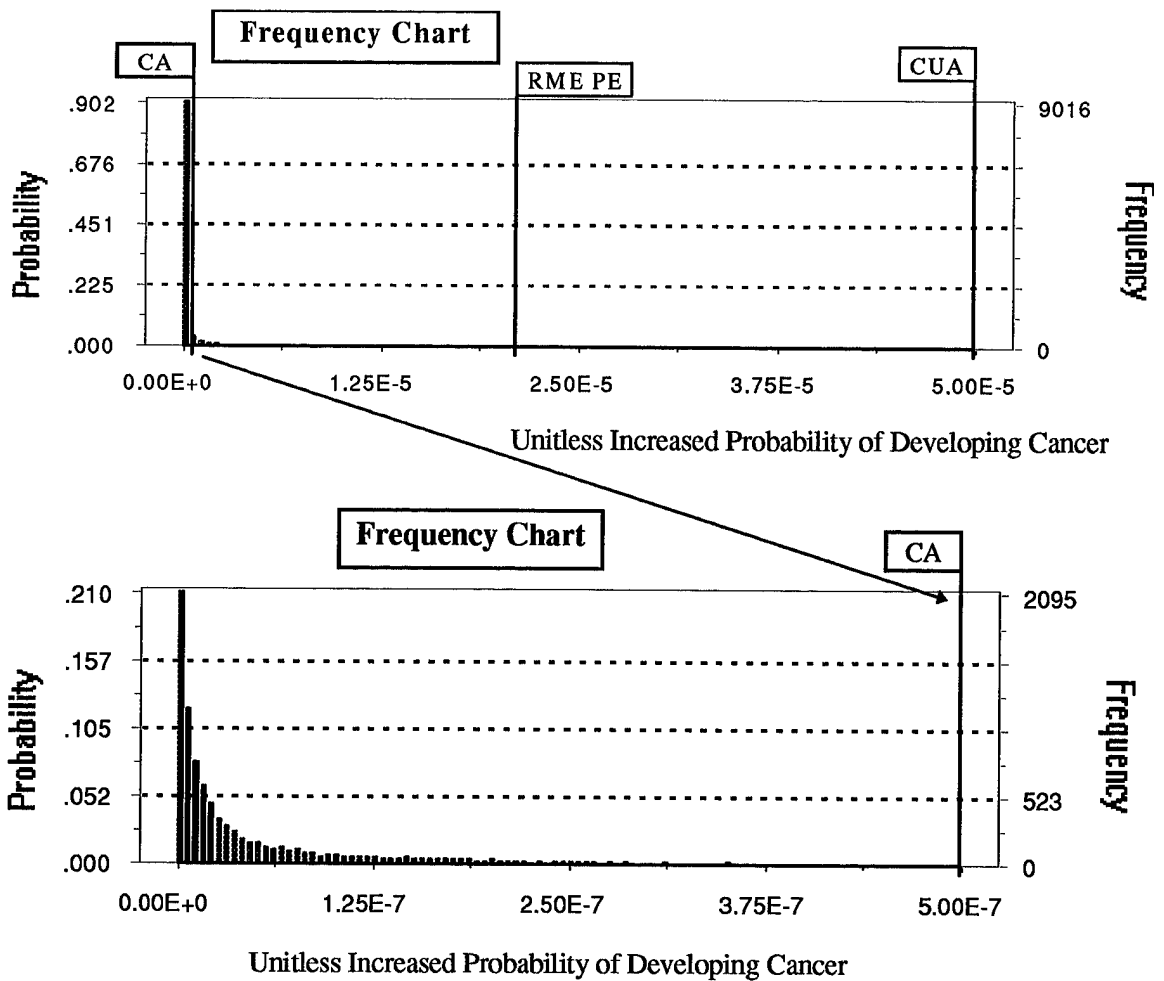

Range and Percentiles										
Min	10%	20%	30%	40%	50%	60%	70%	80%	90%	Max
6.38E-14	1.41E-9	3.63E-9	7.20E-9	1.23E-8	2.08E-8	3.53E-8	6.60E-8	1.43E-7	4.55E-7	2.34E-2

Figure 3-16: Final Results of PRA for OU2 with 14 Samples from RI70%

3.12.1 Probabilistic Uncertainty Analysis Now that a better estimate of the risk distribution has been assessed it is important to quantify how much of the risk distribution consists of variability and how much consists of uncertainty. The percent contribution to variance for each variable is calculated by squaring the Spearman Rank correlation coefficient for the variable. This approximation is used because the calculations of variance contribution can be very complex to perform (McKone, 1994:458). Other more

complex analytical methods discussed by Morgan and Henrion (1990, 185) and McKone (1994) were considered, but were assumed to be too complex for practical field application. This estimate, though not exact, provides a simple method of approximating the contribution to variance that is feasibly calculated in the field. Figure 3-17 shows the approximate contribution to variance for each of the input variables in the final simulated risk distribution using the Crystal Ball approximation.

From section 3.10, it is known that the exposure duration and ingestion rate consist primarily of variability and the oral slope factor, mean concentration, and the exposure frequency consist primarily of uncertainty. The sensitivity analysis provides an estimate of the uncertainty and variability of the risk distribution as suggested by the guidelines (USEPA, 1992a:22929). Figure 3-17 shows that between the exposure duration, ingestion rate and the exposure time, 67.1% of the variance in the risk distribution is primarily attributed to natural variability. 32% is attributable to uncertainty in the slope factor, mean concentration, and exposure frequency. Approximately 3.8% is reducible within the scope of the risk assessment through additional chemical concentration samples and a better estimate of the exposure frequency. The other variables contribute approximately 0.9% of the variability, which was considered negligible. The assessor can use these type of results to present the risk distribution and determine variables for further field investigation to reduce the uncertainty in the risk distribution in subsequent phases.

3.12.2 Reducing the Uncertainty with Additional Samples Usually the only information gathered in a risk assessment is chemical concentration samples. The

uncertainty in the estimate of the mean concentration is reduced with additional samples, but it is important to consider the value of additional samples taken in subsequent RI phases. It is also important to note that the percent contribution to variance of the mean concentration distribution is only 3.8% in this case. This indicates that the accuracy of the estimate of the mean concentration is not critical as was demonstrated in Appendix B.

Sensitivity Chart

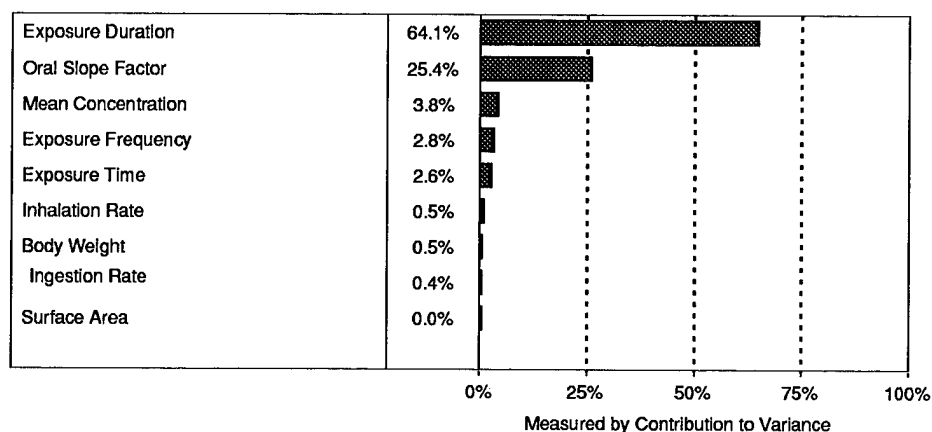

Figure 3-17: Percent Contribution of Variability by Each Variable

The expected reduction in uncertainty in the mean concentration distribution from a projected number of additional of samples can be simulated with the current available information. In Section 3.7.5, 1000, 14 sample vectors were generated from the best fit distribution for the actual benzene concentration in groundwater after the RI70%, which is shown as ARI70% in Figure 3-5. The 1000 vectors were used to calculate 1000 possible means from ARI70% and to estimate the distribution of the uncertainty in the mean concentration with 14 samples from the RI70%, which is shown as MRI70% in Figure 3-6. It is assumed that ARI70% is not going to significantly change with additional samples

from subsequent phases. Therefore, ARI70% is used to predict the expected reduction in the uncertainty of the mean concentration distribution with any number of additional samples. In the RI100% phase of the actual OU2 RI six additional samples were collected. Assuming that the analyst was at the RI70% and the six samples were projected, the predicted reduction in the uncertainty of the mean concentration could be estimated with 1000, 20 sample, vectors from ARI70%. Using the 1000, 20 sample vectors from ARI70%, 1000 means are calculated to predict the 1000 possible means that could result from a 20 sample set from the actual distribution for benzene concentration after the RI100% (ARI100%), which is information not available at the RI70%. This is based on the assumption that ARI70% is not going to be significantly different from ARI100%.

Figure 3-18 is used to illustrate the concept. It is important to note that all the histograms shown are generated from ARI70%, which is based on 14 samples that were available at the RI70%. The first panel shows the histogram of the estimated uncertainty in mean concentration with 14 samples from the RI70%. It is used as the baseline for comparison. The second panel shows the histogram of the predicted mean concentration distribution for a total of 20 samples, expected to be available after the RI100%, using ARI70%. This distribution is called the predicted mean concentration for the RI100% (PMRI100%) phase and is used in the analysis of Chapter 4. Hypothetically assuming 10 more samples were taken after the RI100%, the third panel shows the histogram of the predicted mean concentration distribution for a total of 30 samples. It is provided to show the diminishing reduction in uncertainty with additional samples. The number of

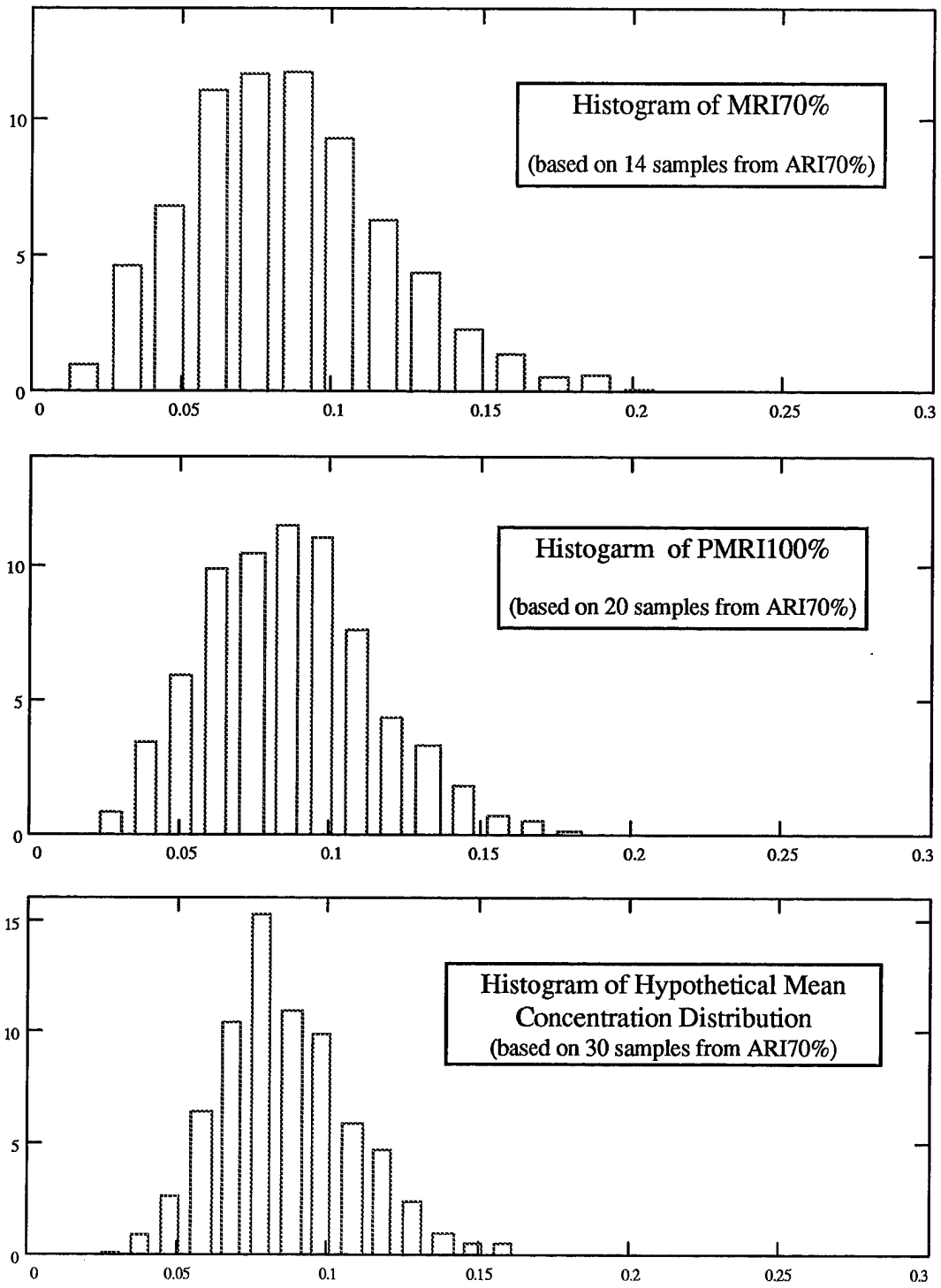

Figure 3-18: Simulated Reduction in the Uncertainty of the Mean Concentration Distribution with Additional Samples

bins in the histograms were all set to 15 and the range on the abscissa was fixed from 0.0 to 0.3 in order to easily compare the three graphs. The graphs show that the variance of the distribution is becoming smaller with additional samples and approaching a Gaussian shape, but it is definitely not normal.

The predicted mean concentration distributions could be put into a probabilistic risk simulation to predict the reduction in uncertainty or predict the change in the risk probabilities. Using Clairmont's decision support model to consider cost, duration, and other decision maker preferences, an analyst can determine if the predicted reduction in the uncertainty in the risk distribution from additional samples, or the value of the information, is worth the expected cost of the additional samples.

3.13 Benefits of Methodology The methodology, herein, demonstrates an iterative process to guide an analyst through the investigation phase. It is not intended to be a step-by-step approach, but instead, a process to objectively guide the analyst on how to most efficiently gather additional information to minimize cost and time. The resulting estimation of the risk distribution effectively describes the range of risks and their likelihood and provides the following benefits above that of the point estimate method:

- Maintains the distinction between risk management and risk assessment (Burmaster and Appling, 1995:2440)
- Avoids the debate over what percentiles are appropriate to estimate the RME
- Quantifies the variability and uncertainty in the final risk estimate
- Provides a wealth of information to make better, more informed decisions (Morgan and Henrion, 1990:44)
- Flexibility to estimate the risk distribution appropriate for the decision being made

4. Analysis and Findings

4.1 Introduction

This chapter focuses on the benefits from the application of the methodology developed in Chapter 3. A portion of two National Priorities List sites are assessed using the probabilistic approach. The risk assessment for a future commercial worker at Operable Unit 2, Wright-Patterson Air Force Base, Ohio, and a current worker at Site 4, Air Force Plant 44 (AFP44), Arizona, are used. Portions of the risk assessments for these two sites are evaluated retrospectively to demonstrate the possible benefits gained from a probabilistic risk assessment and decision analysis tools.

4.2 Future Commercial Worker, OU2

The exposure scenario for a commercial worker exposed to benzene contaminated groundwater was discussed and developed in Chapter 3. The distributions discussed in Section 3.7 still apply and are used in the analysis to conduct a probabilistic risk assessment. The only input risk variable adjusted in the analysis of Chapter 4 is the distribution of the mean concentration.

4.2.1 Benzene Mean Concentration Distributions at OU2 The distribution of the mean concentration at the remedial investigation 70% (RI70%) phase was developed in Section 3.7.5 from the actual best fit distribution for the benzene concentration (ARI70%). The mean concentration distribution at the RI70% is shown in Figure 3-6 as MRI70%. The histogram of the predicted mean concentration for the RI100% (PMRI100%) was discussed and developed in Section 3.12.2 and is shown in Figure 3-17 as PMRI100%. The simulated means used to estimate PMRI100% were input into

ExpertFit, to estimate the best fit distribution (Averill M. Law & Associates, 1995). The 20 samples available at the RI100% phase were also input into ExpertFit to estimate the actual benzene concentration distribution after the RI100% (ARI100%). The estimate of the mean concentration distribution at the RI100% was estimated from ARI100% using the methodology discussed in Section 3.7.5. The best fit distributions, using ExpertFit, for OU2 at the RI70% and RI100% are defined and summarized in Table 4-1. The ExpertFit results for all the distributions and the samples available at the RI70% and the RI100% are available in Appendix B. The gamma distribution is a versatile distribution that can have many of the same characteristics as a lognormal distribution. The parameters shown are the scale parameter (β) first and the shape parameter (α) second.

Table 4-1: Concentration Distributions used for OU2

Mean Concentration Distribution	Benzene
ARI70%	Gamma(0.173347, 0.53410)
MRI70%	Gamma(0.01214, 7.60837)
PMRI100%	Gamma(0.00797, 11.58195)
ARI100%	Gamma(0.17747, 0.46796)
MRI100%	Gamma(0.00864, 9.52396)

ARI70% -- Fitted distribution to actual 14 samples

MRI70% -- Simulated mean concentration distribution with 14 samples ARI70%

PMRI100% -- Predicted RI100% mean concentration distribution with 20 samples from ARI70%

ARI100% -- Final fitted distribution with all 20 samples

MRI100% -- Final simulated mean concentration distribution with 20 samples from ARI100%

Figures 4-1 and 4-2 provide a visual summary of some of the key distributions. Figure 4-1 shows the ARI100% best fit distribution overlaid on the histogram of the 20 samples from the RI100%. This distribution is provided as the baseline distribution from which all the other distributions are compared. Figure 4-1 also shows the MRI70% and MRI100% distributions to present the simulated reduction in uncertainty gained from an

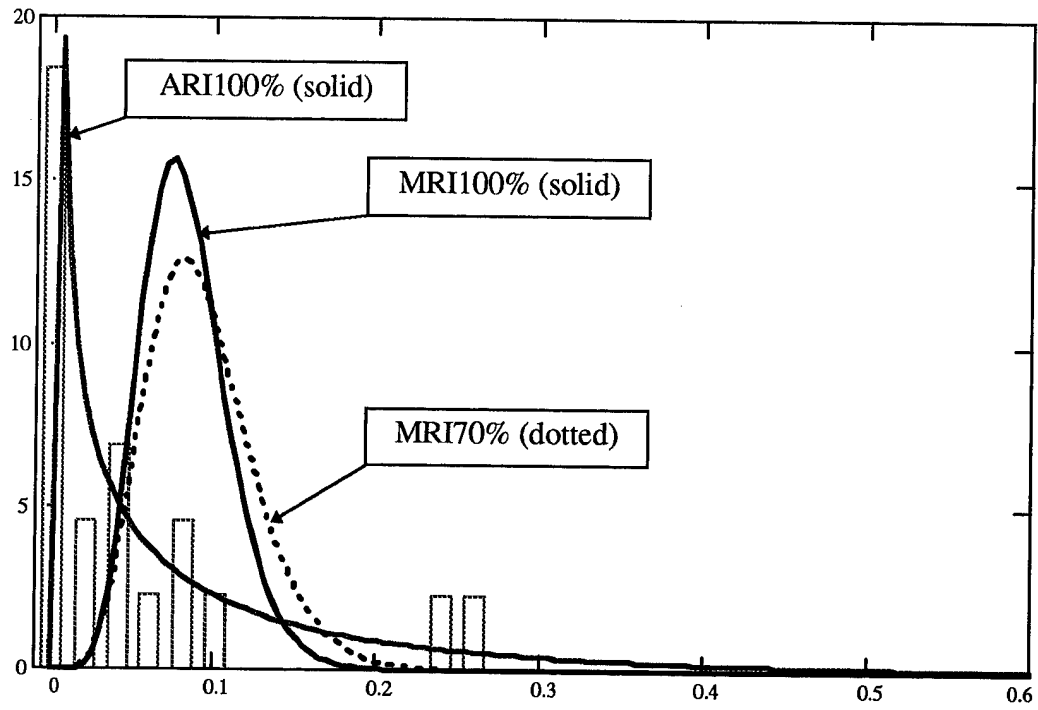

Figure 4-1: The Reduction in Uncertainty of the Mean Concentration Distribution

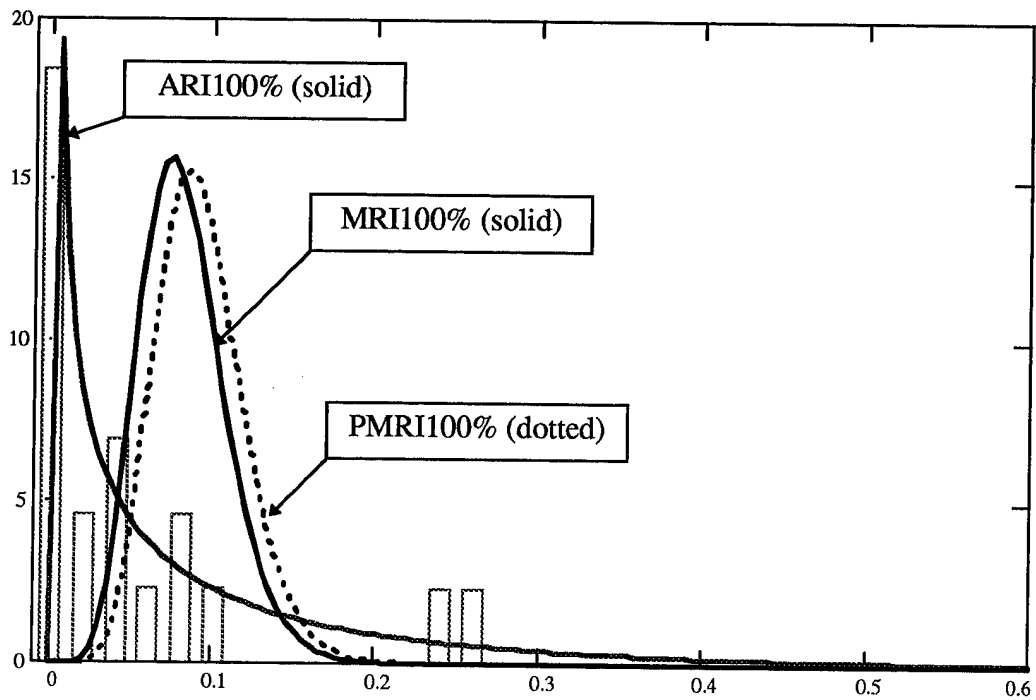
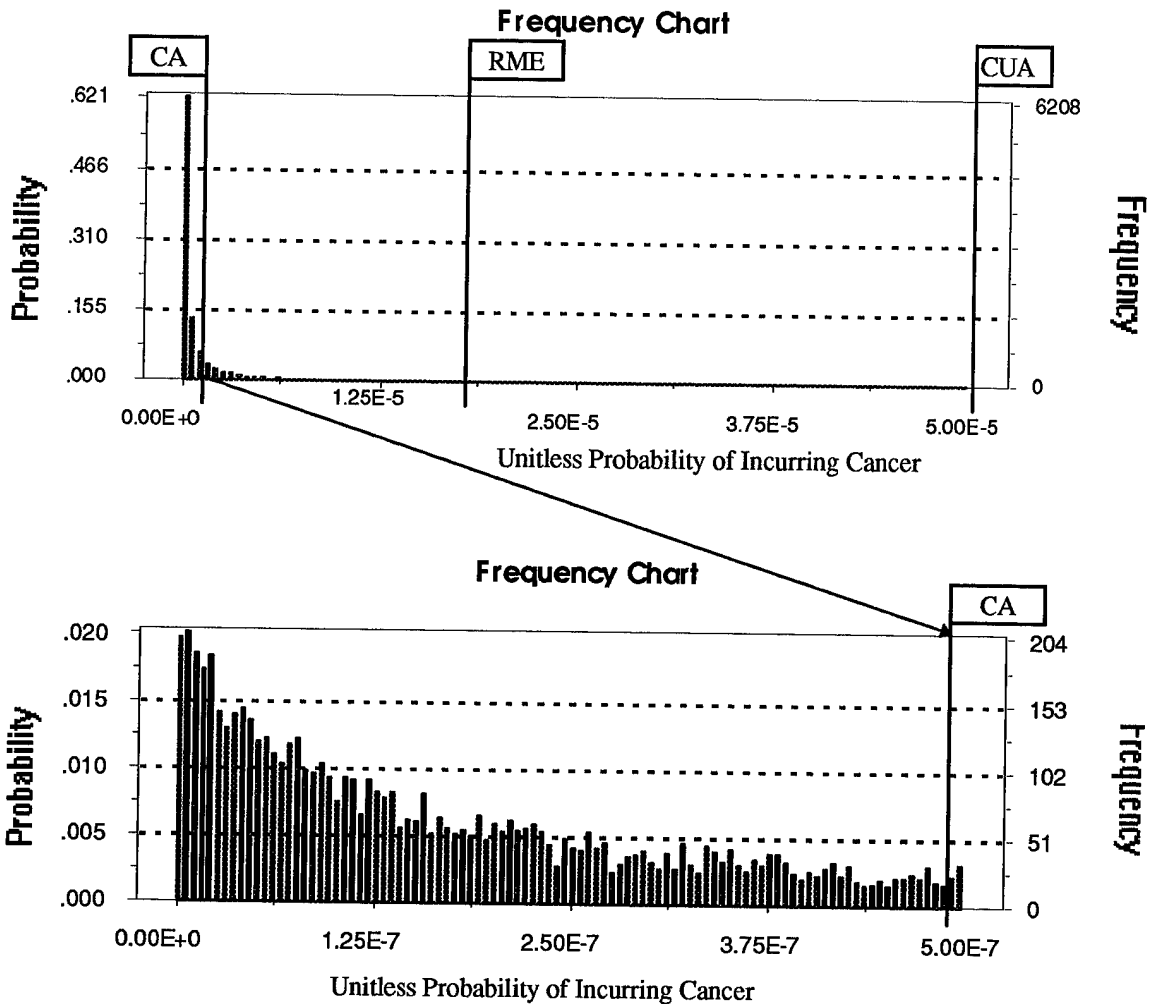

Figure 4-2: A Comparison of the PMRI100% and the MRI100%

additional 6 samples from the RI100%. This is in essence is what the decision maker gains for the cost of the RI100% for benzene.

Figure 4-2 shows the same RI100% best fit distribution overlaid on the histogram of the 20 samples, but in this figure the PMRI100% and the MRI100% distributions are given for comparison. The figure shows that the simulation predicted mean concentration distribution for the RI100% and simulation mean concentration distribution after the RI100% are approximately the same. There is a slight discrepancy between the two that is discussed in Section 4.4

4.2.2 Probabilistic Risk Simulation for OU2 Three different probabilistic risk simulations were run to estimate the risk probabilities to input into Clairmont's decision support model. At the RI70%, when only 14 samples were available, two simulations were run to estimate the information known at the RI70%. The first simulation used the MRI70% distribution to estimate the risk distribution and the risk probabilities with the available information after the RI70%. The RI70% risk distribution and percentiles are shown in Figure 4-3. The risks shown are unitless probabilities of an individual developing cancer (USEPA, 1989c: Ch 8, 11) within the population of concern due to exposure to benzene in the groundwater. The first panel shows the histogram of risks from zero to the CUA level $5 \cdot 10^{-5}$ (unitless), which encompasses 99.51% of the values. The second panel zooms in on the range of values from zero to the CA level of $5 \cdot 10^{-7}$ (unitless) of risk. Key percentiles and statistics for the distribution are shown in Tables 4-2 and 4-3.



Range and Percentiles

Min	10%	20%	30%	40%	50%	60%	70%	80%	90%	Max
8.37E-11	1.25E-8	6.44E-8	1.13E-7	1.87E-7	2.90E-7	4.56E-7	7.34E-7	1.32E-6	3.19E-6	9.85E-5

Figure 4-3: Results of Initial RI70% Risk Distribution

The second risk simulation used the predicted mean concentration distribution for the RI100% (PMRI100%) to predict the reduction in the uncertainty of the final RI100% risk distribution from a projected additional 6 samples. The predicted RI100% risk distribution (PRI100%) is not provided because, as expected, it is almost identical to the actual RI100% risk distribution. If the PRI100% risk distribution were provided it would

be identical to the distributions representing the actual RI100% distribution in Figure 4-4. The only way to distinguish the PRI100% and RI100% risk distributions is to evaluate the key percentiles and statistics for the two distributions, which are shown in Tables 4-2 and 4-3.

The third risk simulation used the actual estimated mean concentration distribution (MRI100%) as an input to estimate the actual final risk distribution (RI100%). The results of the risk simulation using MRI100% are shown in Figure 4-4 in a similar format to Figure 4-3. The first panel shows the histogram of risks from zero to the CUA level $5 \cdot 10^{-5}$ (unitless), which encompasses 99.76% of the values. The second panel zooms in on the range of values from zero to the CA level $5 \cdot 10^{-7}$ (unitless) of risk. The RME risk at the RI100% estimated in the actual risk assessment was $5.1 \cdot 10^{-5}$ (unitless) (Earth Sciences, 1993:Appendix H). The estimated RME risk is used to compare the results of the probabilistic risk assessment to a deterministic risk assessment. Key percentiles and statistics are provided in Table 4-2 and 4-3 for the RI70%, predicted RI100%, and the actual RI100% risk distribution. They are provided together for a more detailed comparison of the distributions and simulation results.

The risk probabilities were explained in detail in Section 2.6.2.2, but basically the probability the risk is low is the area under the risk distribution to the left of the CA level, the probability the risk is medium is the area under the curve between the CA and the CUA levels, and the probability the risk is high is the area to the right of the CUA level. These are used as inputs to the decision support model discussed in Section 2.6.

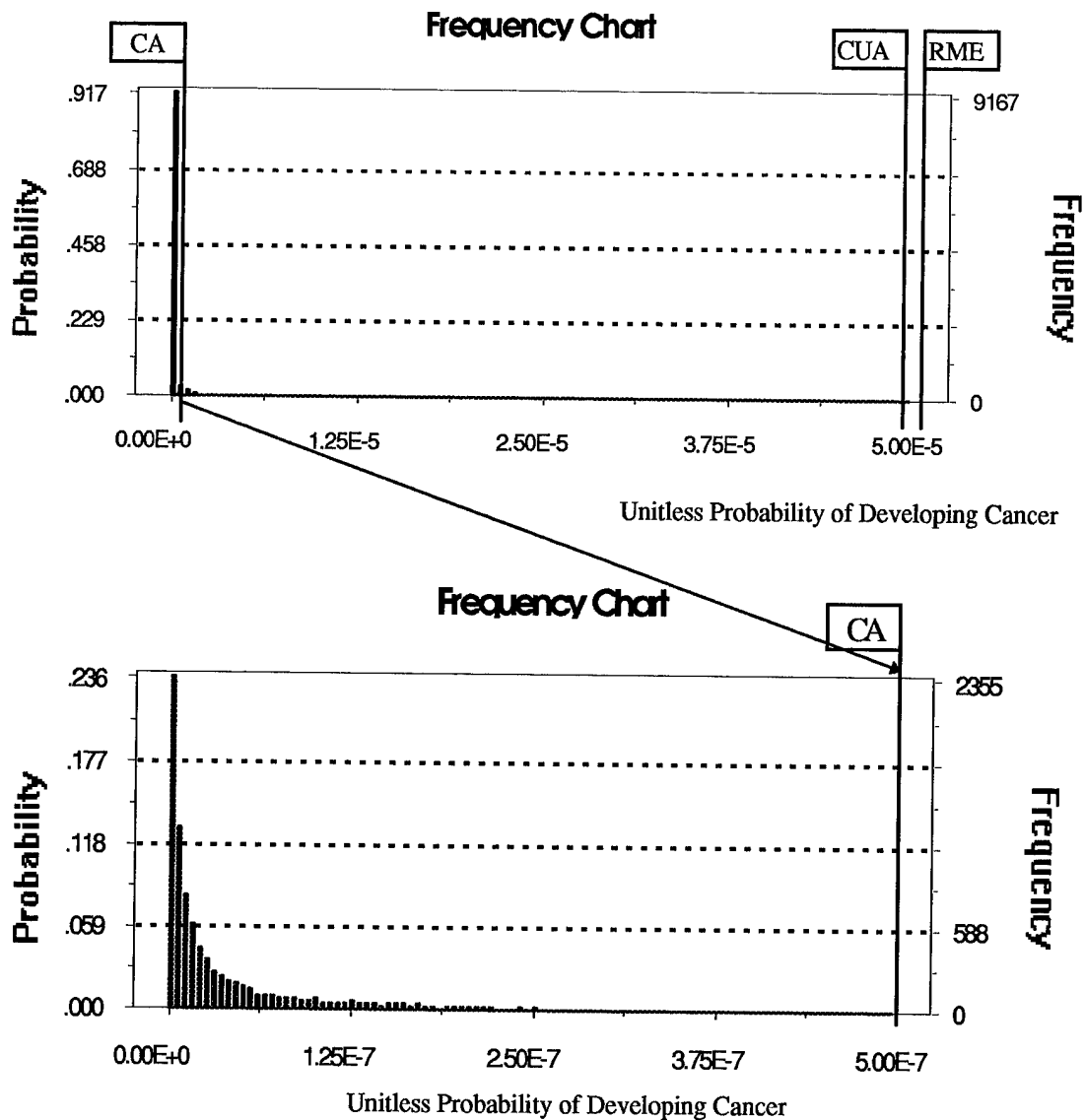

Range and Percentiles

Min	10%	20%	30%	40%	50%	60%	70%	80%	90%	Max
8.19E-14	1.47E-9	3.48E-9	6.47E-9	1.10E-8	1.88E-8	3.21E-8	5.79E-8	1.26E-7	3.88E-7	2.05E-3

Figure 4-4: Results of PRA for OU2 with 20 Samples from RI100%

There are three significant findings to point out from the results of the risk simulation. All of the findings are based on the RI100% risk distribution because it is derived from all the information available. The first is the significant difference between

the risk probabilities assessed in Clairmont's model, shown in Table 3-7, and the probabilistic risk assessment probabilities in Table 4-3. Clairmont, like most risk assessors, used default conservative values that, when combined, produced extreme risk scenarios. The RI100% risk distribution is very skewed so the high risks on the distribution are present, but have a very small likelihood of occurring. The combination of these two effects produced probabilities of a high risk that differed by a factor of 322 and probabilities of a low risk that differed by a factor of 61. The difference in the probabilities has serious implications on the recommended decision as shown in the third finding.

Table 4-2: Selected Percentiles From PRA Simulations for OU2

Percentiles	50%	60%	70%	80%	90%	95%	Max Value
RI70%	2.18E-8	3.74E-8	7.03E-8	1.58E-7	4.55E-7	1.27E-6	4.55E-4
PRI100%	2.26E-8	3.81E-8	6.82E-8	1.51E-7	4.47E-7	1.20E-6	2.14E-3
RI100%	2.05E-8	3.53E-8	6.43E-8	1.35E-7	4.25E-7	1.11E-6	1.46E-3

RI70% -- Risk Distribution with information available after 14 samples

PRI100% -- Predicted Final Risk Distribution with 14 samples

RI100% -- Final Risk Distribution with all 20 samples

Table 4-3: Key Statistics from PRA Simulations for OU2

Simulation	Percentiles			Risk Probabilities		
	CA	CUA	RME PE	Low	Med	High
RI70%	90.46%	99.51%	99.52%	0.9046	0.0905	0.0049
PRI100%	90.62%	99.74%	99.74%	0.9062	0.0912	0.0026
RI100%	90.92%	99.76%	99.76%	0.9092	0.0884	0.0024

The second finding is the information about the likelihood of the reasonable-maximum-exposure (RME) risk estimated in the actual risk assessment (Engineering Science, 1995:Appendix H). As discussed in Section 1.2, the EPA conceptually defines the high end risk as the "risks above the 90th percentile of the population distribution, but

not higher than the individual in the population who has the highest risk” (USEPA, 1992b:24). Using a Monte Carlo approach with distributions that have no upper bound, the guidelines also assume that any exposure values on the exposure distribution between the 99.5th and 99.9th percentile, depending on the population size, could be the maximum exposures the population might experience (USEPA, 1992a:22923). All exposure values above the 99.9th percentile on the risk distribution are considered maximum exposures (USEPA, 1992a:22923). The guidelines assume the high end exposures are associated with the high end risks (USEPA, 1992b: 24). The results in Table 4-3 show that the estimated RME risk of $5.1 \cdot 10^{-5}$ (unitless) may be very close to the maximum risk an individual in the population may experience. The simulation estimated that 99.76% of the risk values would be less than the RME risk.

The 95th percentiles of the risk distribution is generally considered to be a good estimator of a reasonable maximum risk (Burmester and Appling, 1995:2439; Finley and Paustenbach, 1994:70; Smith, 1994:438; Thompson *et al.*, 1994:56). The RME risk is 46 times greater than the 95th percentile risk value of $1.11 \cdot 10^{-6}$ (unitless). At the 99.76th percentile, which results in probability of 0.0024 of any risk being greater to or equal to the RME risk of $5.1 \cdot 10^{-5}$ (unitless), the estimated RME risk is more likely to be a maximum risk and a significantly conservative estimate of the risk present to a commercial worker. The RME risk is possible, but with a probability of 0.0024 that any risk would be equal to or greater than the RME risk it is highly unlikely that an individual would receive this combination of events (USEPA, 1992b:23). This finding supports the assumptions and findings of Chapter 1.

4.2.3 Decision Analysis for OU2 The third finding results from using the risk probabilities in Clairmont's decision support model. To aid the RPM in considering the multitude of uncertainties in the complex remedial investigation, discussed in Section 1.2, the risk probabilities shown in Tables 4-3, along with the other factors in Appendix D, were input into Clairmont's decision support models. Two different decision support models were run to represent the RI70% and RI100% phases. Only the information available after the RI70% was used in the RI70% decision support model. All the information available was used in the RI100% decision support model. In the first run, the risk probabilities for the RI70% distribution and the probabilities for the PRI100% were used in the decision support model to determine the recommendation of the RI70% decision support model. The cost, duration, and decision maker preference inputs to the model are shown in Appendix D.

Considering all the information, the recommendation at the RI100%, based on the analysis of the decision support model, is to take no further action (NFA). The results of the decision support model are shown in the decision tree in Figure 4-5. For a review of the use of decision trees, the reader is encouraged to read Winston (1994) or Clemen (1991). Briefly, the squares indicate a major decision that must be made, the circles indicate an uncertain value that results after the preceding decision is made, and the triangles indicate a possible final outcome. In this particular decision tree, the major decision is what action to take at the RI70%. The dark line shows the recommended path. In this case, the NFA alternative is recommended at the RI70%.

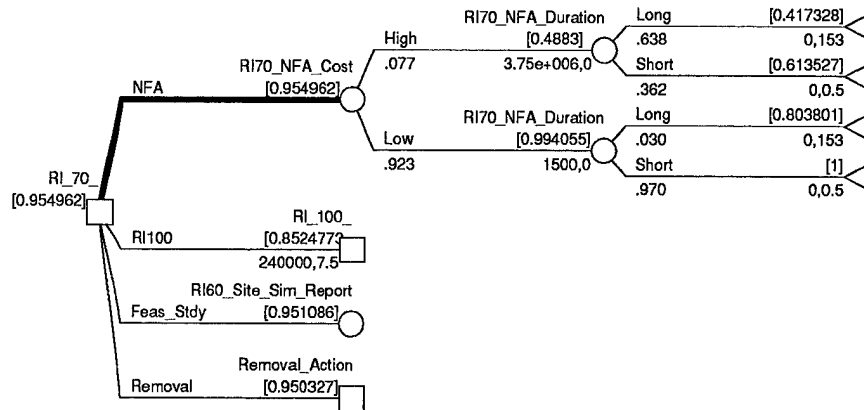

Figure 4-5: Recommendation for OU2 After RI70%

If a NFA is taken, there are two uncertain results (cost and duration) and four possible combinations of those results. The costs and durations shown are expected costs and durations. If NFA is the wrong decision, a high cost (\$3.75 million) and long duration (153 months) are incurred due to improperly characterizing the risk. These calculations are made according to the logic presented by Clairmont (1995, 57). The other possible outcome of NFA decision is that it is the correct decision in which case a cost of \$1500 and a duration of 0.5 months are incurred. The possible outcomes of cost and duration result in a utility of 0.9550 for the NFA alternative that outperforms the other decision strategies. This makes the NFA decision the optimal decision based on the decision makers preference for money and time. This RI70% decision support model recommendation takes into account the predicted reduction in the uncertainty of the risk distribution from an additional 6 samples. This indicates that the predicted reduction in the uncertainty of the risk distribution gained from the predicted reduction in the uncertainty of the mean concentration is not worth the cost of gathering the additional information.

The RI100% decision support model was run with the risk probabilities from the final RI100% risk distribution, and the inputs from Appendix E to determine the recommendation at the RI100%. Once again the recommendation, with a slightly better utility of 0.9711, is that NFA be taken as shown in Figure 4-6. The information is presented in a format similar to Figure 4-5. The recommendation comes as no surprise, since the percentiles and statistics for the predicted (PRI100%) risk distribution and the actual (RI100%) risk distribution are very similar. It is critical to point out that the recommendation made with the information available at the RI70% phase is consistent with the recommendation made with all the information available after the RI100%.

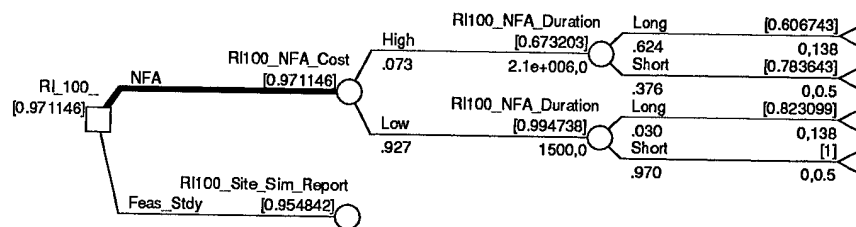

Figure 4-6: Recommendation for OU2 After RI100%

One difference in the recommendations in Figures 4-5 and 4-6 is the costs and durations of making the NFA decision at the RI70% versus the RI100%. It is assumed that the cost of making the same wrong decision at the RI100% (\$2.1 million and 138 months) is less because less of the remedial investigation would have to be redone (Clairmont, 1995, 57). Using equations 4-1 and 4-2, Clairmont calculated the cost and duration for the possibility of making the wrong decision at any phase in the RI. It is assumed that if a high NFA cost and duration are incurred, the wrong decision was made.

$$\text{NFA_Cost_High} = \text{NFA_Cost_High_Multiplier} \cdot \left(\frac{\sum(\text{high estimate of remaining study costs})}{\max(\text{high estimate of remediation costs})} \right) + \quad (4-1)$$

$$\text{NFA_Dur_High} = \text{NFA_Dur_High_Multiplier} \cdot ((\sum \text{high estimate of future study costs}) + \text{max}(\text{high estimate of remediation durations})) \quad (4-2)$$

(Clairmont, 1995:57)

The NFA_Cost_High is an estimate of the NFA cost if the NFA decision strategy is the wrong alternative. The NFA_Dur_High is an estimate of the NFA duration if the NFA decision strategy is the wrong alternative. Clairmont assumes that if the NFA decision is the wrong decision, the responsible parties will be able to reinstate the remedial investigation and the studies that were not conducted will have to be completed to make the right decision (Clairmont, 1995:56). Clairmont also recognized that, if a mistake was made in deciding to take NFA, some time would pass before the effects of the risk had a chance to manifest themselves in the population of concern. Because it is difficult to estimate the future cost of making the wrong NFA decision, Clairmont assumed the worst case scenario for the high cost and duration of the NFA alternative. All the highest expected costs and durations for the subsequent phases are used to calculate the high NFA cost and duration.

Clairmont also took into account the fact that, if the NFA decision is the wrong decision, the future costs of the remaining remediation investigations will be greater than the estimated present day costs, by using the NFA_Cost_High_Multiplier and NFA_Dur_High_Multiplier. These multipliers also take into account other costs such as “potential lawsuits, bad public relations, health problems and other intangible effects of making the wrong decision” (Clairmont, 1995:56). Because these cost are difficult to quantify, they are discussed with the decision maker and they decide the values of the multipliers. The cost multipliers for OU2 can be seen in Appendix D and E. The cost and

duration multipliers are assumed to be within the range of 1 to 2 (see appendix D and E for justification). The high NFA cost and duration are recalculated for every phase of the remedial investigation and feasibility study (RI/FS).

The importance of the assumptions and calculation for the high cost and duration of a NFA decision is that there is worst-case cost and duration scenario that must have a small likelihood of occurring before the NFA action alternative is selected by the decision support model. This cost gets smaller as more studies are completed because there is less studies that have to be reinitiated and there less chance of making the wrong decision with more information. This is why the high cost and duration of making the same NFA recommendation is less when it is made the RI100% phase as opposed to the RI70% phase.

Another important result is that the action recommended from a better estimation of the risk distribution, as shown in Figure 4-5 and 4-6, differs from the recommendation derived in Clairmont's model for benzene contaminated groundwater, which consisted of a removal action followed by a feasibility study to determine the best remediation alternative (Clairmont, 1995:97). The difference in the recommendations is based on the difference between the risk probabilities discussed on page 91. A removal action in this case indicates any action that reduces the exposure to the benzene contaminated groundwater, such as limited access to the contaminated area.

One of the purposes of this research is to minimize the cost of the investigation phase by providing a method for determining whether additional information should be gathered or whether the decision to take appropriate action should be made without

further investigation. According to the decision support model, the recommendation to take NFA could have been made at the RI70% without the additional 6 samples from the RI100%. This is a limited analysis in that it only took into account one chemical, but, based on the extensive research done by Clairmont, the probabilistic risk approach and the decision support model together might have saved at least \$2.4 million (in 1995 dollars) and 17 months in the remedial investigation (Clairmont, 1995:101).

Whether any time or money could have been saved in clean-up due to the low probabilities of unacceptable risks is dependent on two things. First, other chemicals that showed a significant risk would have to be assessed to determine their risk probabilities and the decision support model recommendations. Second, it is difficult to assess whether the expected cost of groundwater remediation of \$875,000 (Clairmont, 1995:F-4) could have been avoided based on substantially lesser risks because the decision maker must take account other social and political factors into account, which are not considered in the decision support models, when making the decision.

4.3 Commercial Worker, AFP44

The second risk assessment that was evaluated was the noncancer risk to a current commercial worker at AFP44 exposed to contaminated soils. Dermal absorption and inhalation of contaminated dust were the two intake routes identified in the original risk assessment (Earth Technology Corporation, 1993: Ch3, 213). Antimony (Sb), Cadmium (Cd), and Chromium (Cr) are evaluated because 95% of the total hazard index was attributed to these metals. The initial deterministic point estimate values and calculations were taken from the actual risk assessment (Earth Technology Corporation, 1993: Ch 3,

213). The input values, individual intake route hazard indices, and total hazard index are shown in Table 4-4. The equations used to calculate the intakes were taken from the guidelines (USEPA, 1989c:Ch 6, 41; USEPA, 1991a:53). All exposure variables in the risk assessment were represented by the guideline recommended values. With the exception of the mean concentration, all the chemical specific variables were taken from the Integrated Risk Information System (IRIS) (USEPA, 1994). The reference doses (RfD) are based on the information available in IRIS in 1992 when the assessment was conducted. The total RME hazard index of 12.55 indicates that the commercial worker was being exposed to a daily intake that was 12.55 times more than the regulated safe RfD. Since the unacceptable level of noncancer risk is 1.00, according to the remedial project manager, any RME hazard index greater than or equal to 1.00 should result in clean-up, which was exactly the action taken in this case.

4.3.1 Site 4 Input Distributions To assess the risk using probabilistic techniques, the variables were researched in the similar iterative process described as in Chapter 3. The distributions for exposure frequency (EF), exposure duration ED (ED), and body weight (BW) explained in Section 3.7 were used because they applied to this scenario. The air concentration (AC) was estimated through underlying calculations not shown in the Table 4-4. These calculations were broken down, according to the risk assessment, to estimate the uncertainty in the AC and are explained in Section 4.3.1.3. The IR point estimate was taken from the guidelines (USEPA, 1991b: Attachment A). Because information on this variable was available in the literature, it was evaluated according to a study by Layton

(1993) and is discussed in Section 4.3.1.4. Each of the distributions not addressed in the risk simulation model for OU2 is addressed individually.

Table 4-4: RME Risk Calculations for Commercial Worker at Site 4

Reasonable Maximum Exposure Hazard Index			
Dermal Absorption of Chemicals from Surface Soils			
	Antimony (Sb)	Cadmium (Cd)	Chromium (Cr)
CS - Mean Soil Concentration (mg/kg) (Normal 95% UBCL of mean)	39.0	11.8	939.0
CF - Conversion Factor (kg/mg)	1E-6	1E-6	1E-6
SA - Surface Area (cm ² /event)	3120	3120	3120
AF - Skin Adherence Factor (mg/cm ²)	1.45	1.45	1.45
ABS - Absorption Factor (unitless)	0.01	0.01	0.01
EF - Exposure Frequency (days/year)	250	250	250
ED - Exposure Duration (year)	25	25	25
BW - Body Weight (kg)	70	70	70
AT - Averaging Time (days)	9125	9125	9125
CDI - Chronic Daily Intake (mg/kg-day)	1.73·10 ⁻⁵	5.22·10 ⁻⁶	4.16·10 ⁻⁴
DRfD - Dermal Reference Dose (mg/kg-day)	8.40·10 ⁻⁶	1.25·10 ⁻⁵	1.05·10 ⁻⁴
RME Noncancer Hazard Index	2.06	0.42	3.96
Inhalation of Contaminated Dust			
	Antimony (Sb)	Cadmium (Cd)	Chromium (Cr)
AC - Mean Concentration in Air (mg/m ³)	*	*	8.40·10 ⁻⁶
IR - Inhalation Rate (m ³ /8hr-day)	*	*	20
EF - Exposure Frequency (days/year)	*	*	250
ED - Exposure Duration (year)	*	*	25
BW - Body Weight (kg)	*	*	70
AT - Averaging Time (days)	*	*	9125
CDI - Chronic Daily Intake (mg/kg-day)	*	*	3.48·10 ⁻⁶
IRfD - Inhalation Reference Dose (mg/kg-day)	NA	NA	5.70·10 ⁻⁷
RME Noncancer Hazard Index	*	*	6.11
Total Hazard Index for Commercial Worker Population			12.55

4.3.1.1 Mean Soil Concentration The following is a brief review of the sampling strategy and the method for calculating the mean concentration for each chemical used in the risk assessment and Table 4-4. Forty-five surface soil samples were collected at a depth of one foot in accordance with a systematic grid sampling plan (Gilbert, 1987:21). Twenty additional samples were collected from soil borings at the suspected points of contamination in accordance with a search sampling plan (Gilbert, 1987:23). In the risk assessment, the 95% upper bound confidence limits (UBCL) of the mean concentration were calculated with the 65 soil samples collected. To calculate the 95% UBCL, the analysts assumed the mean concentrations were normally distributed (Earth Technology Corporation, 1993:Ch 3, 74).

The 45 surface soil samples encompassed 70% of the data and were used as the information known at the remedial investigation (RI) 70%. The 65 samples encompassed 100% of the data and were used as the information known at the remedial investigation (RI) 100%. The distributions required for the analysis at Site 4 were all derived according to the same logic and methodology outlined in Section 4.2.1 for OU2. The distributions used for the chemicals at Site 4 are summarized in Table 4-5. The Expertfit (Averill M. Law & Associates, 1995) results for the distributions of each chemical can be seen in Appendix G. The parameters shown for the Weibull and Gamma distributions of Antimony are the scale parameter (β) first and the shape parameter (α) second. The parameters for the lognormal distributions of Cadmium and Chromium shown in Table 4-5 are the arithmetic mean first and arithmetic standard deviation of the log-transformed data.

The graphical summaries like those provided in Section 4.2.1 for benzene are provided in Appendix G.

Since the 20 additional samples were biased high because they were taken at points of known or suspected contamination, the parameters for the RI100% distributions tend to be slightly higher than those for the RI70% distributions. This contributes to the difference in the predicted (PMRI100%) and actual (MRI100%) mean concentration distribution for all three chemicals, which impacts the risk simulations as shown in Section 4.3.2

Table 4-5: Distributions used for Risk Simulation at Site 4

Distributio	Antimony	Cadmium	Chromium
ARI70%	Weibull(6.6306, 0.7463)	Lognormal(-0.110, 1.631)	Lognormal(3.461, 1.629)
MRI70%	Gamma(24.1588, 0.3304)	Lognormal(1.066, 0.407)	Lognormal(4.787, 0.446)
PMRI100%	Gamma(38.3902, 0.2045)	Lognormal(1.101, 0.361)	Lognormal(4.803, 0.385)
ARI100%	Weibull(6.6582, 0.7992)	Lognormal(3.772, 1.745)	Lognormal(3.604, 1.713)
MRI100%	Gamma(42.5576, 0.1782)	Lognormal(1.434, 0.406)	Lognormal(4.985, 0.393)

ARI70% -- Fitted distribution to actual data after RI70%

MRI70% -- Simulated mean concentration distribution with 45 samples from ARI70%

PMRI100% -- Predicted RI100% mean concentration distribution with 65 samples from ARI70%

ARI100% -- Final fitted distribution with all 65 samples

MRI100% -- Final simulated mean concentration distribution with 65 samples from ARI100%

4.3.1.2 Surface Area The skin surface area for a commercial worker was based on the surface area of hands and arms for men. The distributions of these body parts have been developed by the USEPA (1991). The distributions for the surface area of arms and hands are estimated by normal distributions in Figures 4-7 and 4-8 respectively. The distributions for the surface area of arms has a mean of 2280 cm² and a standard deviation of 374 cm² (USEPA, 1991:Ch 4, 10). The distributions for the surface area of hands has a mean of 840 cm² and a standard deviation of 127 cm² (USEPA, 1991:Ch 4, 10). The

default estimate was based on the sum of the means of the two distributions. These two distributions were randomly sampled in the risk simulation and their samples were summed to propagate the uncertainty in the exposure surface area..

No correlation between these two variables was used because it has been shown that correlations between variables that have little influence on the risk distribution can safely be ignored (Smith *et al.*, 1992:473). The Spearman rank correlation coefficient, an indicator of the relative importance, was 0.04 for the distribution of the surface area of arms and 0.00 for the distribution of hands. The Spearman rank correlation coefficients compared to the correlation coefficients of other variables for all the risk simulation at site for can be seen in Table 4-8 of Section 4.4. Another reason why ignoring the correlations between these two variables and other variables within the risk simulation is appropriate is that all the distributions used in the risk simulation are for men between the ages of 30 and 60. Using specific distributions based on age and sex, where most of the interdependencies arise, reduces the effect of neglecting correlations between variables significantly (Finley and Paustenbauch, 1994:57).

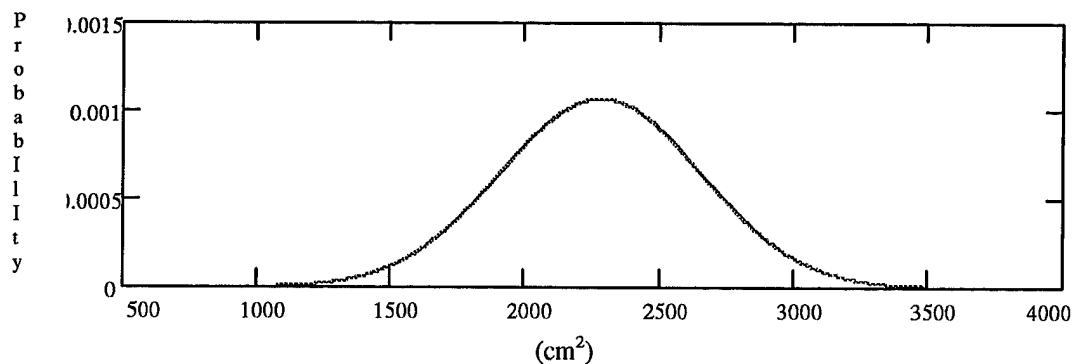

Figure 4-7: Distribution for Surface Area of Arms for Men

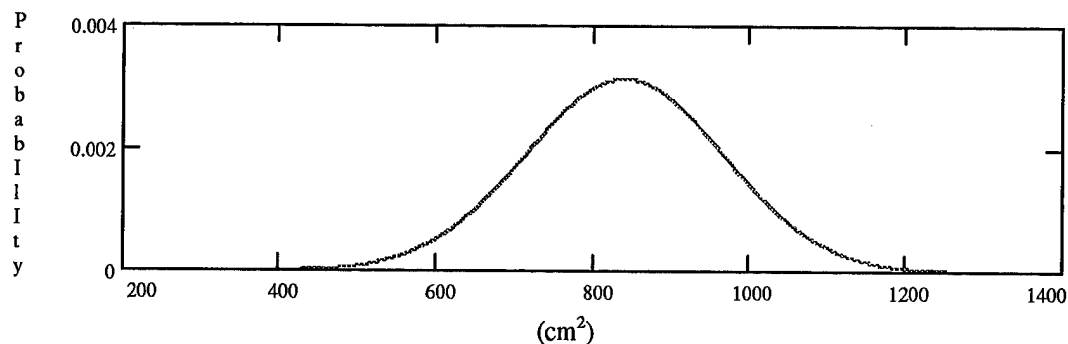

Figure 4-8: Distribution for Surface Area of Hands for Men (cm²)

4.3.1.3 Air Concentration Since metals do not volatilize, it is assumed that they are transported into the air through contaminated fugitive dust. The concentration in the air is directly related to amount of dust in the air. The dust in the air was quantified with measurements taken on particulate with aerodynamic diameters less than or equal to 10 μ m (PM10) (Masters, 1991, 273). The aerodynamic diameter is used to determine how far a particulate is likely to penetrate into the lungs where it is possibly absorbed or fixed. The PM10 is generally the amount of airborne soil per cubic meter of air. An estimate of the concentration of metals in the air was calculated in the actual risk assessment using Equation 4.1 (Earth Technology Corporation, 1993: A3, 185). A maximum PM10 of $1.90 \cdot 10^{-8}$ kg/m³-air and an average PM10 of $1.26 \cdot 10^{-8}$ kg/m³-air were reported in 1991 for the local AFP44 area (Earth Technology Corporation, 1993: A3, 185).

$$AC \text{ (mg/m}^3\text{)} = CS(\text{mg/kg-soil}) \cdot PM10(\text{kg-soil/m}^3\text{-air}) \quad (4.1)$$

The 95% UBCL of the air concentration (AC) was found by multiplying the 95% UBCL of the mean concentration for chromium with the maximum PM10 of $1.90 \cdot 10^{-8}$ kg-soil/m³-air, which resulted in an air concentration $8.40 \cdot 10^{-6}$ mg/m³ of chromium (Earth

Technology Corporation, 1993: A3, 185). Since the PM10 is physically constrained to values greater than zero, three points were available to estimate a conservative triangular distribution shown in Figure 4-7. This distribution was used to conservatively represent the uncertainty in the PM10 value with limited information. The PM10 distribution was not significantly influential so the triangular distribution is an adequate representation of the variability and/or uncertainty in PM10. The soil concentration for Chromium was repeatedly sampled and multiplied by a random sample from the PM10 distribution to estimate the distribution of uncertainty and/or variability of the AC. The equation for the mode of a triangular distribution when the minimum, average, and the maximum are known is provided in Equation 4.2.

$$\text{mode} = 3 \cdot (\text{average}) - \text{minimum} - \text{maximum} \quad (4.2)$$

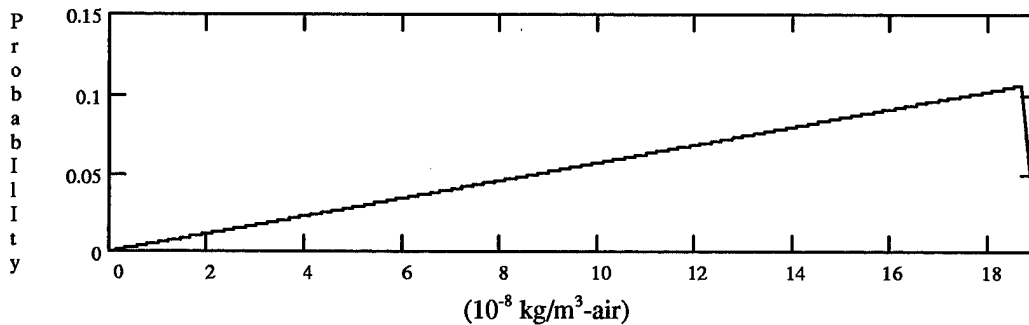

Figure 4-9: Distribution of Uncertainty in PM10

4.3.1.4 Inhalation Rate According to Layton, 1993, the inhalation rate is a function of the three variables described in Equation 4.3. The variables are briefly defined below, but the reader is encouraged to reference the article for a more detailed discussion of the variables and derivations.

$$\text{IR} = E \cdot H \cdot VQ \quad (4.3)$$

Where,

- “E = energy expenditure rate, kJ/day;
- H = volume of oxygen (at standard temperature and pressure, dry air; or STPD) consumed in the production of 1 kJ of energy expended, L/kJ and
- VQ = the ventilatory equivalent, ratio of the minute volume to oxygen uptake rate, unitless” (Layton, 1993:25)

The energy expenditure rate is a function of the basal metabolic rate (BMR) and an activity level multiplier (A) as shown in Equation 4.4.

$$E = \text{BMR} \cdot A \quad (4.4)$$

The BMR is dependent on body weight, sex, and age. Some specific functions for men and women were developed and presented by Layton. The function of BMR for men between the ages of 18 and 30 was found to be best estimated by $0.063 \cdot \text{BW} + 2.896$. The body weight, in kilograms, was sampled and used to determine the appropriate BMR. According to the personnel at AFP44, the activity of the commercial worker was defined as light to moderate, which corresponds to an activity multiplier of 1.3 to 1.8 with the most likely value of 1.6 (Layton, 1993:28). The triangular distribution in Figure 4-10 is used to conservatively account for the variability and uncertainty in A with limited information. The value for H is presented as a constant equal to 0.05 L O₂/kJ, which is based on an average of multiple studies (Layton, 1993:26). The VQ for adults was statistically fit and shown to be well represented by a lognormal distribution with an arithmetic mean of 27.53 (unitless) and an arithmetic standard deviation of 4.56 (unitless) (Layton, 1993:26). The distribution for VQ is shown in Figure 4-11. The function for BMR and the distributions for A and VQ were used to propagate the uncertainty in the inhalation rate.

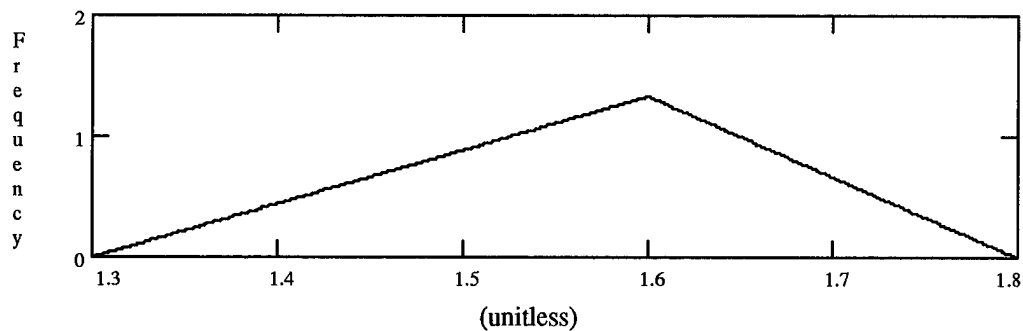

Figure 4-10: Distribution of Activity Level Multiplier for Commercial Worker

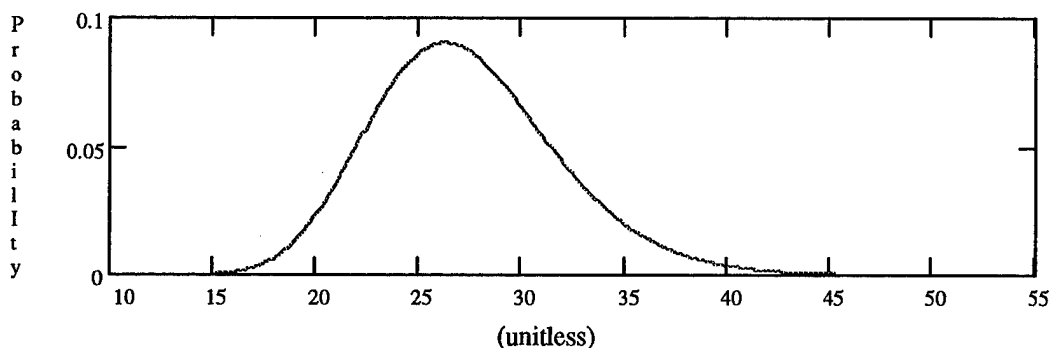

Figure 4-11: VQ for Adults (unitless)

4.3.1.5 Reference Doses As was discussed in Section 2.3.2, the RfD is based on an experimental no-observed-adverse-effect level (NOAEL) that has been modified by uncertainty factors. The following is a brief overview of how the uncertainty in the RfD can be represented (Baird *et al.*, 1996). For a more detailed discussion of the use of uncertainty factors to extrapolate a RfD the reader is encouraged to reference Kenneth and Erdreich, 1989; Kimmel, 1990; and Barnes and Dourson, 1988. To extrapolate an RfD the USEPA begins with some experimental threshold (ET) dose. The term ET is used because it may be the NOAEL or the lowest-observable-adverse-effect level (LOAEL), if a NOAEL is not available, that is used to extrapolate the RfD (Kimmel, 1990: 191). The ET is then divided by a number of uncertainty factors that apply. The

possible number of uncertainty factors used to derive the RfD are shown in Equation 4.5 (Baird *et al.*, 1996: 82).

$$\text{RfD} = \frac{\text{ET}}{\text{UF}_{\text{AH}} \cdot \text{UF}_{\text{HV}} \cdot \text{UF}_{\text{S}} \cdot \text{UF}_{\text{L}} \cdot \text{UF}_{\text{D}} \cdot \text{MF}} \quad (4.5)$$

Where,

- UF_{AH} -- the uncertainty for extrapolating from animal to human
- UF_{HV} -- the uncertainty for extrapolating from average human to sensitive human
- UF_S -- the uncertainty for extrapolating from subchronic to chronic
- UF_L -- the uncertainty factor from a LOAEL to NOAEL
- UF_D -- the uncertainty factor when there is limited data for a chemical
- MF -- a modifying factor for any other particular uncertainties that may apply

These uncertainty factors typically take on the value of 10, which is based on a study by Dourson and Stara (1983) that established the EPA's 10-fold uncertainty factor (Baird *et al.*, 1996:81). Because there is variability in the response to a dose by individuals in a population, these uncertainty factors must also have some natural variability. The 10-fold factor is a conservative upper bound value used to account for the variability in the uncertainty factors (Kimmel, 1990: 192). Instead of using a conservative point estimate that requires risk assessment and risk management to determine an appropriate value, a probabilistic approach attempts to maintain the separation of science and policy (Baird *et al.*, 1996:82).

To estimate the uncertainty in the RfD, Baird *et al.* broke down equation 4.5 and evaluated the uncertainty factors individually. Baird *et al.* incorporated much of the same data used to estimate the EPA's 10-fold uncertainty factor to derive a distribution for UF_{AH}, UF_{HV}, UF_S, and UF_L. The two other uncertainty factors were not evaluated because the study excluded compounds for which the EPA had used limited data or

modifying uncertainty factors (Baird *et al.*, 1996:90). For a complete justification of the following distributions the reader is encouraged to read the study by Baird *et al.* (1996). The parameters of the distributions are the arithmetic mean first and arithmetic standard deviations, respectively.

$$\begin{aligned} UF_{AH} &\sim \text{Lognormal} (20.505, 69.535) \\ UF_{HV} &\sim \text{Lognormal} (5.609, 1.942) \\ UF_S &\sim \text{Lognormal} (2.634, 2.256) \\ UF_L &\sim \text{Lognormal} (3.914, 2.232) \end{aligned}$$

The reported RfD in the actual risk assessment (Earth Technology Corporation, 1993:Ch 3, 213) for each compound was multiplied by the total uncertainty factor, which was also provided in the risk assessment (Earth Technology Corporation, 1993:Ch 3, 145, 147) to determine the initial NOAEL for the chemical in 1992 when the information was taken from the Integrated Risk Information System (IRIS) (USEPA, 1994). As was mentioned earlier, these uncertainty factors are typically set at a value of 10. In some cases, of the risk assessment for Site 4, a value less than 10 was used for a particular uncertainty factor. The distributions presented above were still used in an attempt to maintain the separation of science and policy. These calculations are shown below. The underscore indicates the UFs are random variables that follow their particular distribution defined above.

$$DRfD_{Sb} \sim \frac{(4 \cdot 10^{-6} \text{ mg / kg - day}) \cdot (1000)}{(\underline{UF_{AH}}) \cdot (\underline{UF_{HV}}) \cdot (\underline{UF_S})}$$

$$DRfD_{Cd} \sim \frac{(1 \cdot 10^{-5} \text{ mg / kg - day}) \cdot (10)}{(\underline{UF_{AH}})}$$

$$\text{DRfD}_{\text{Cr}} \sim \frac{(1 \cdot 10^{-4} \text{ mg / kg - day}) \cdot (500)}{(\text{UF}_{\text{AH}}) \cdot (\text{UF}_{\text{HV}}) \cdot (\text{UF}_{\text{S}})} \quad (\text{Dermal})$$

$$\text{IRfD}_{\text{Cr}} \sim \frac{(5 \cdot 10^{-7} \text{ mg / kg - day}) \cdot (300)}{(\text{UF}_{\text{AH}}) \cdot (\text{UF}_{\text{HV}}) \cdot (\text{UF}_{\text{S}})} \quad (\text{Inhalation})$$

The numerator is an estimate of the NOAEL in 1992, which is divided by an estimate of the distribution for the appropriate uncertainty factors. These equations were used in the simulation to estimate the distribution of uncertainty in the noncancer toxicity values in the probabilistic risk assessment.

4.3.2 Risk Distribution Results for Site 4 All the distributions presented in Section 4.3.1 were used to estimate the uncertainty in the estimated risk. Like OU2, three PRA simulations were run. The only distributions that were changed between the three simulations are the distributions for the mean concentration for each chemical in Table 4-5. The MRI70% distribution was used to estimate the risk distribution with the 45 samples available at the RI70%. The PMRI100% distribution was used in the second simulation to predict the RI100% risk distribution and risk probabilities with an expected 6 additional samples. The MRI100% distribution was used in the third PRA simulation to estimate the RI100% risk distribution.

Like the results for OU2, only the RI70% and RI100% risk distributions and percentiles are shown in Figures 4-12 and 4-13 respectively because the predicted RI100% risk distribution (PRI100%) looks very similar to final risk distribution with the information available after the RI100%. The clearly acceptable (CA) and clearly unacceptable (CUA) levels of noncancer risk were both set at one by the remedial project manager, therefore, there is only a low and high probability of risk. The probability that

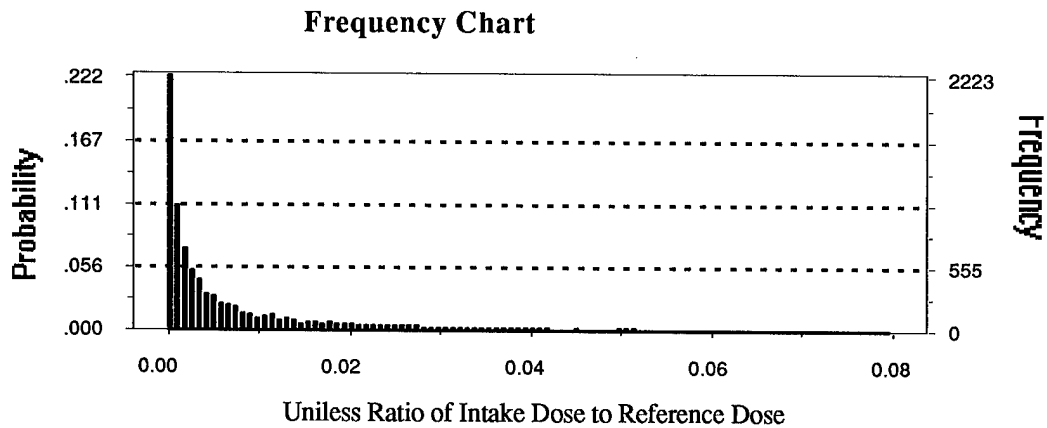
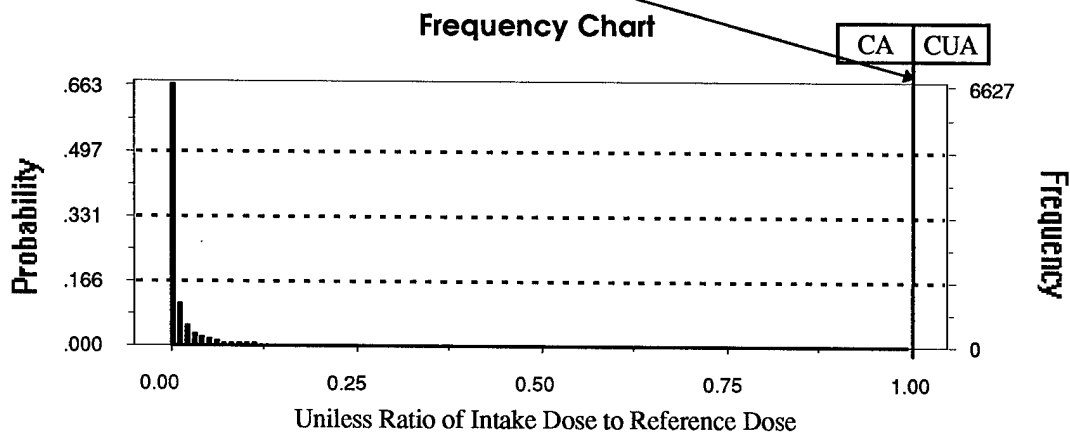
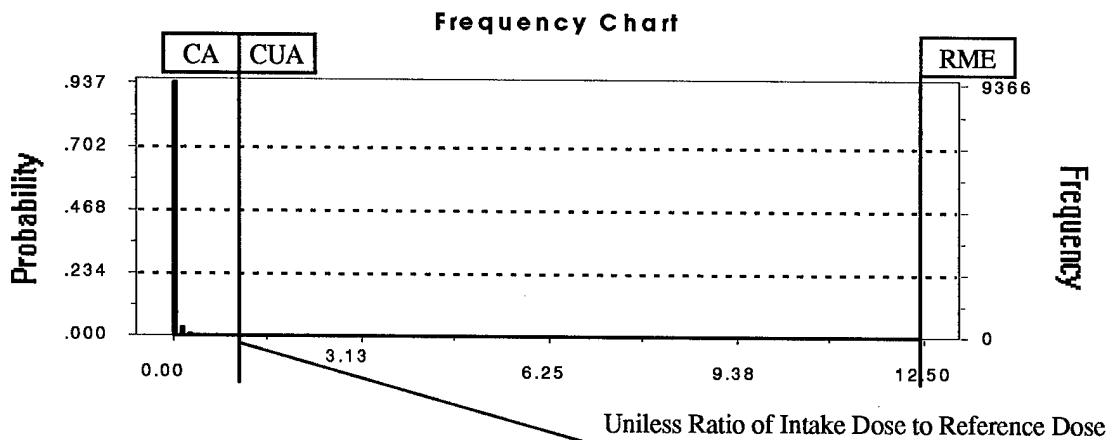

Range and Percentiles

Min	10%	20%	30%	40%	50%	60%	70%	80%	90%	Max
0.00	0.00	0.00	0.00	0.00	0.00	0.01	0.01	0.03	0.08	22.56

Figure 4-12: Results of PRA from Site 4 with 45 Samples from RI70%

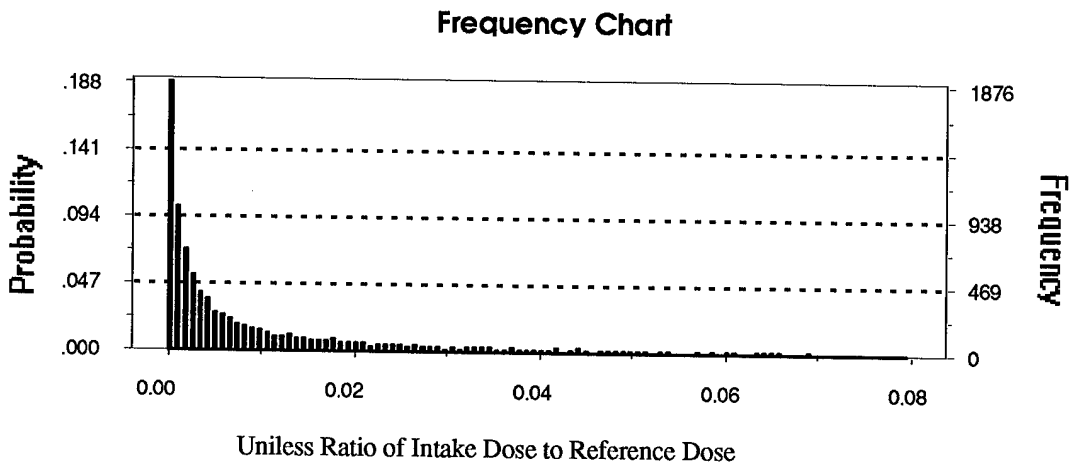
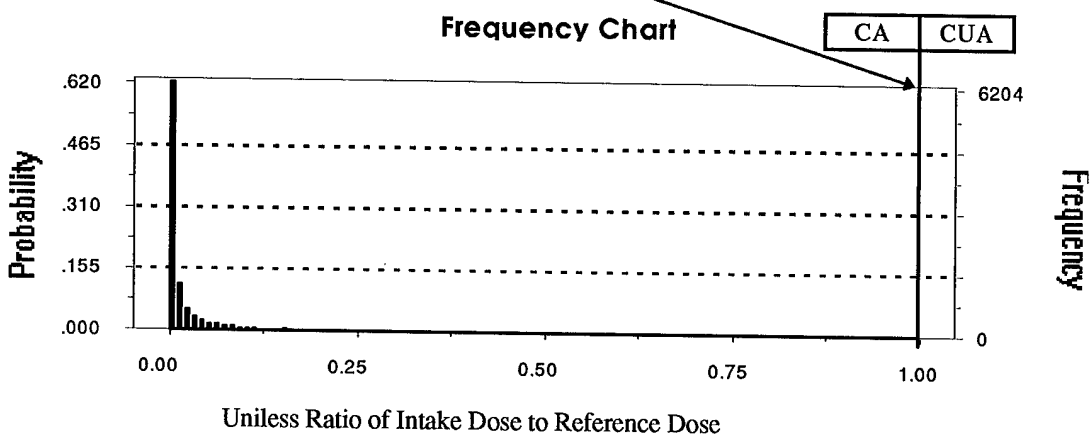
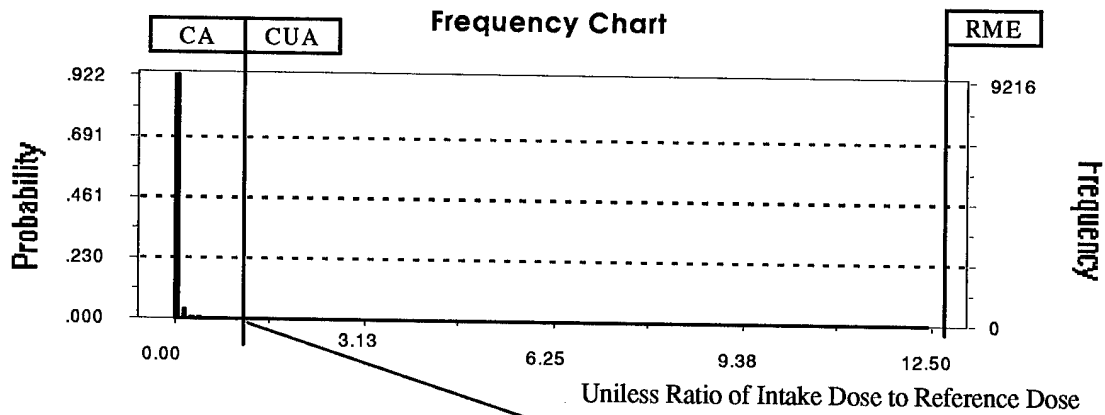

Range and Percentiles

Min	10%	20%	30%	40%	50%	60%	70%	80%	90%	Max
0.00	0.00	0.00	0.00	0.00	0.00	0.01	0.02	0.03	0.08	22.56

Figure 4-13: Results of PRA from Site 4 with 65 Samples from RI100%

the risk is low (or CA) is the area under the risk distribution curve to the left of one and the probability that the risk is high (or CUA) is the remaining area to the right of the one. The first panel of Figures 4-12 and 4-13 shows the histogram of the risk values from zero to the RME point estimate of 12.55. The second panel shows the risk values from zero to the CA and CUA level of one. The third panel shows the risk values from zero to 0.08, which encompasses 90% of the risk values in both graphs. The key percentiles and statistics for all three distributions are shown in Table 4-6 and 4-7 for a more detailed comparison of the distributions and results.

Table 4-6: Selected Percentiles From PRA Simulations for Site 4

Percentiles	50%	60%	70%	80%	90%	95%	Max Value
RI70%	0.00	0.01	0.01	0.03	0.08	0.18	22.56
PRI100%	0.00	0.01	0.01	0.03	0.07	0.17	46.36
RI100%	0.00	0.01	0.02	0.03	0.08	0.19	57.41

RI70% -- Risk Distribution with information available after 45 samples

PRI100% -- Predicted RI100% Risk Distribution with 45 samples from ARI170%

RI100% -- Final Risk Distribution with all 65 samples

Table 4-7: Key Statistics from PRA Simulations for Site 4

Simulation	Percentiles			Risk Probabilities	
	CA	CUA	RME PE	CA	CUA
RI70%	99.05	0.95	99.71	0.9905	0.0095
PRI100%	99.29	0.71	99.72	0.9848	0.0071
RI100%	98.07	0.93	99.69	0.9907	0.0093

The results of the PRA simulation for Site 4 are similar to the results of OU2. There are only two findings evaluated for Site 4 because the site cannot be compared to any previous evaluation like OU2. The findings are all based on the RI100% risk distribution, since it is based on the most information available. The first finding is that the risk simulation shows that approximately 99.69% of all the risks are below the RME.

Because of the large skewness in the distribution the 95th percentile risk value and the RME risk value differ by a factor of 66. Once again, in accordance with the logic presented in Section 4.2.2, this shows that the RME risk is possible, but highly unlikely. With a probability of 0.0031 that any risk is equal to or greater than the RME risk, the RME hazard index of 12.55 is more likely a maximum risk and is assumed to significantly overestimate the risk to a commercial worker due to the contaminated soil. This finding also corresponds to the assumptions and findings of Chapter 1.

4.3.3 Decision Analysis for Site 4 The second finding results from the decision analysis of Site 4. In this case the recommendations are quite obvious because the probabilities of CUA risks are so low. The cost, duration, decision maker preferences, and other input information can be seen in Appendix F. Considering the probabilities for the RI70%, the predicted probabilities for the RI100%, and the inputs in Appendix G, the recommendation shown in Figure 4-14 was made at the RI70% phase. Using the probabilities for the actual RI100%, the recommendation to take no further was made and is shown in Figure 4-15. As with the OU2 scenario, the recommendations are consistent in both phases.

The recommended optimal decision strategy presented in a similar format described in Section 4.2.1. The results show that, as with OU2, the decision to take an appropriate NFA could have been recommended at an earlier stage in the RI process. The additional information gathered to reduce the uncertainty in the mean exposure concentration was not expected to significantly change either the risk probabilities or optimal decision strategy.

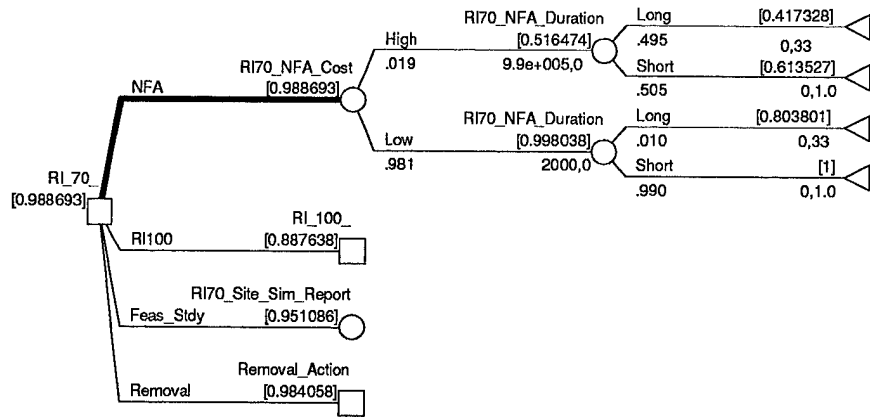

Figure 4-14: Decision Support Model Recommendations at the RI70% for Site 4

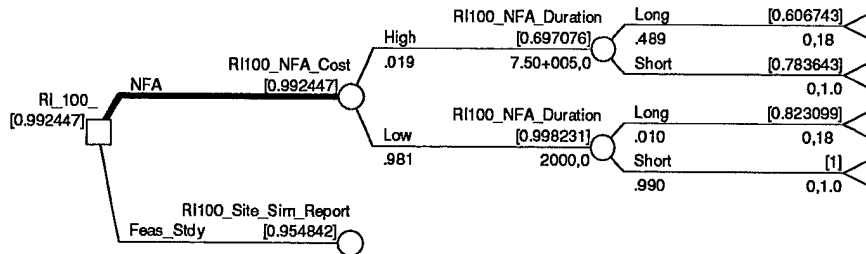

Figure 4-15: Decision Support Model Recommendations at the RI100% for Site 4

The potential for savings presented by using the probabilistic approach and the decision support model can only be analyzed from the resources spent in the RI. The cost saving for Site 4 might have been at least \$200,000 (in 1996 dollars) and 2 months from the additional 20 samples taken. The cost analysis based on an average cost of \$10,000 per sample for the total RI at Site 4. This was for one site of the 15 at AFP44. Whether the expected cost of clean up of \$4,500,000 (in 1996 dollars) could have been avoided based on lesser risks is difficult to determine because not all risks were evaluated and the decision maker must take into account other economical, social, and political factors when making the final decision.

4.4 Marginal Returns of Reducing the Uncertainty The results show that when value of information is not considered resources may be expended unnecessarily. The results in Table 4-3 and Table 4-7, indicate that the added information from the additional samples from subsequent RI100% studies, in both cases, did not significantly change the risk distribution or the risk probabilities. This is due to the fact that the investigation phase is typically focused on one variable. Concentration samples are taken in order to reduce the uncertainty in the estimated risk. After the uncertainty in the mean concentration is reduced to some point a continued reduction results in only marginal returns. Finkel and Evans in their article "Evaluating the Benefits of Uncertainty Reduction in Environmental Health Risk Management" explained it best:

This reflects the common-sense notion that the "weakest link" in a chain of uncertainties will limit the benefits of research. If one variable affecting the risk cannot be known with more precision than a factor of 1000, for example, the benefit of refining the estimate of another variable will diminish rapidly once it is known within a factor of 100 or so. (Finkel and Evans, 1987)

In both examples presented, it is demonstrated that the benefit of the continued investigation on the chemical concentration rapidly diminished after the RI70%.

One tool that can be used to determine whether the mean concentration distribution is a "weak link" in the chain of uncertainties is to use the sensitivity analysis techniques discussed in Section 3.10. Table 4-8 provides the Spearman rank correlation for every variable for every simulation. The coefficient provides a metric on how the range of a random variable correlates to the range of risks in the risk simulation. The variables representing the mean concentrations are highlighted. The mean concentration distribution (CW) at OU2 had a Spearman rank correlation coefficient of 0.15, 0.12, and

0.15 for the three simulations. Note that when these correlation coefficient are compared to the coefficients of other, more influential, variables, it suggests that the CW is relatively less influential to the risk distribution. This may explain why, even though the actual mean concentration distribution (MRI100%) and predicted mean concentration distribution (PMRI100%) for the RI100% phase in Figure 4-2 were slightly different, there was not a significant difference in the predicted risk probabilities (PRI100%) and the actual risk probabilities (RI100%) of the risk distribution for OU2. Also in the RI100% simulation, the ED is almost five times as influential, and the Oral-SF is three times as influential as the mean concentration.

Table 4-7: Spearman Rank Correlation Coefficients

Location	OU2, WPAFB				Site4, AFP44		
Variable	Simulation			Variable	Simulation		
	RI70%	PRI70%	RI100%		RI70%	PRI70%	RI100%
ED	0.73	0.74	0.73	ED	0.71	0.71	0.72
Oral SF	0.48	0.47	0.48	UF _{AH}	0.44	0.43	0.41
CW	0.15	0.12	0.15	UF _{HV}	0.38	0.36	0.37
EF	0.12	0.17	0.14	EF	0.17	0.17	0.17
ET	0.14	0.13	0.14	UF _L	0.15	0.15	0.13
BW	-0.07	-0.07	-0.07	Cr-MC	0.09	0.09	0.08
Inh_R	0.07	0.08	0.06	PM-10	0.09	0.07	0.06
Ing_R	0.06	0.04	0.04	Cd-MC	0.08	0.08	0.08
SA	0.00	-0.02	-0.00	BW	-0.08	-0.09	-0.07
				VQ	0.02	0.03	0.03
				Arms	0.02	0.03	0.04
				Sb-MC	0.01	0.02	0.01
				Hands	0.00	0.00	0.00
				A	0.00	-0.02	0.00

In the case of Site 4 the difference is a little more apparent and the point is more obvious. The chromium mean concentration (Cr-MC) had the highest correlation

coefficient of 0.09. At this site the estimate of each individual mean concentration distribution is not as critical as mean concentration at OU2. A good example of this is the set of estimates of the Cadmium mean concentration distributions (Cd-MC), which had a correlation coefficient of 0.08. From Table 4-6 and Appendix B, it is apparent that the MRI100% distribution was not predicted very well. This is in part because of the biased sampling in the last 20 samples. Regardless of the difference in the mean concentration distributions, however, there was not a significant effect on results of the risk distribution or the risk probabilities. This is due to the fact that the Cd-MC is not a very influential variable, compared to other variables.

This analysis does not indicate that the mean concentration will always be a less influential variable only that an analyst must be aware of how influential it is in the risk simulation. In a case where the risk is an acute toxicity risk and the exposure duration is measured in minutes and the exposure frequency is one, the exposure concentration may be the only influential variable. It is important to keep a perspective of which variables are driving the risk distribution when considering the possibility of gathering additional information. By not considering value of information or the relative importance of the mean concentration, the marginal returns of reducing the uncertainty in the mean concentration beyond the RI70% were gained at a considerable cost.

5 Conclusions and Recommendations

5.1 Conclusions

In the past 25 years a considerable amount of resources have been spent on the remediation of past hazardous waste disposal sites governed under the Comprehensive Environmental Response, Compensation, and Liabilities Act of 1980. The majority of the remediation resources have been consumed by costly and lengthy remedial investigation studies to characterize the human health risk present (Lawrence, 1993:2963; Ember, 1993:19). The excessive cost and duration of characterizing the site has been spurred on by two reasons.

The first reason is the liabilities for improperly characterizing the risk at a site. To deal with the liabilities of improperly characterizing the risks, decision makers and regulators have relied on conservative assumptions to ensure the risks were not underestimated. In estimating the reasonable maximum exposure risk many of the risk variables are represented by conservative, recommended guideline values. When combined in the risk calculations, these conservative values produce risk scenarios that may significantly overestimate the risk. Two examples were evaluated in Chapter 4 to show that the RME risk using the default guideline values significantly overestimate the risk. Using a probabilistic risk assessment it was shown the RME risk estimate for a commercial worker at Operable Unit 2 (OU2), Wright-Patterson Air Force Base, Ohio, was approximately at the 99.76th percentile of the estimated risk distribution. A probabilistic risk assessment of the risk to a commercial worker at Site 4, Air Force Plant 44, Arizona, also showed that the RME risk estimate, based on the guideline

recommended value is approximately at the 99.51th percentile of the estimated risk distribution.

Generally the 95th percentile of the risk distribution is considered to be an estimate of the RME risk (Burmaster and Appling, 1995:2439; Finley and Paustenbach 1994: 70). In the case of OU2, the RME risk was 46 times greater than the 95th percentile of the risk distribution and for Site 4 the RME risk was 66 times greater than the 95th percentile. Though the remedial decision at Site 4 and OU2 were made much more confidently with an extremely conservative estimate of the risk, they may have been made at the with significant remedial investigation and clean-up costs that may have been avoided if the risk were estimated using a more scientifically based methodology.

The second reason for the seemingly excessive cost and duration of remedial investigations is the complexity of making the remedial decisions. Unable to deal directly with the uncertainty resulting from the convolution of the uncertainties in a multitude of variables, and heavily persuaded by the liabilities, decision makers and regulators have relied on conservative assumptions and more studies to take appropriate actions. The value of the information (VOI) from additional studies is often not evaluated or considered. This is partially due to the fact that when decisions are complex, VOI is difficult to assess without the aid of analytical tools, which environmental analysts have not been afforded. As demonstrated in Sections 4.2.3 and 4.3.3 for OU2 and Site 4 respectively, if VOI is not considered, a substantial amount of resources may be expended on subsequent remedial investigation studies to marginally reduce the uncertainty in the estimated risk.

The environmental problems of the future are expected to grow and resources to deal with those problems will be limited. The remediation of hazardous waste sites under CERCLA and the more current sites under the Resource Conservation and Recovery Act's Corrective Action Program is expected to carry the need for an efficient remediation decision process well into the next century (Bredehoeft, 1994:95). The remediation decision process must evolve toward a more objective methodology to ensure that resources are applied to the greatest opportunity for risk reduction (SAB, 1990:16). Studying the site does not reduce any risks so risk analysts and decision makers must be afforded tools and techniques to move as quickly and efficiently as possible from the investigation phase to an appropriate remedial action.

The main objective of this research is to provide tools and techniques to aid risk analysts in determining whether it would be beneficial to gather additional information or whether the decision to take an appropriate action can be made without further investigation. This research provides some probabilistic risk assessment and decision analysis techniques to avoid using simple conservative assumptions to deal with the complex uncertainties and evaluate the VOI of additional studies in the complex remediation decision process. There are three underlying objectives in this research, which support the main research objective, including: (1) provide a better method for estimating the uncertainty in the pollutant mean concentration distribution, (2) provide a method for estimating the reduction in the uncertainty of the estimate in the mean concentration from additional samples (3) provide a method to avoid using conservative assumptions to deal with the uncertainty in the risk variables and the final risk value, (4)

and verify the possible benefits gained from using a probabilistic risk assessment over the EPA's current deterministic point estimate approach. Each objective and how it was achieved is briefly discussed below.

The first objective was important because statistical assumptions are usually made about the pollutant concentration that may not be valid with environmental data. Due to the underlying theory of risk assessment, the mean pollutant concentration is used in the risk calculation. Using the Central Limit Theorem, the assumption is typically made that the uncertainty in the estimate of the mean concentration is normally distributed and respective statistics are used to calculate the 95% upper bound confidence limit (UBCL) of the arithmetic mean. It was shown, Section 3.7.5 that this assumption may not be valid with highly skewed environmental data and small sample sizes, which are common in the initial stages of the remedial investigation.

A methodology for more appropriately estimating the distribution of the uncertainty in the estimate of the mean concentration of highly skewed distributions and small sample sizes is provided in Section 3.7.5.1. Using an optimal best fit distribution of the actual pollutant concentration samples, 1000 n-size sample vectors were generated, from which 1000 means were calculated, to estimate a range of means that could result from a set of n samples from the actual pollutant concentration distribution. Where n is the number of samples available to the risk analyst when the mean concentration is being estimated. An optimally fit distribution was fit to the histogram of the 1000 means, which represents an estimate of the uncertainty in the estimate of the mean concentration. A distribution provides much more information and allows for uncertainty analysis that is not

available with point estimate approach of using the 95% UBCL of the mean. This methodology also allowed for the accomplishment of the third objective. A method for predicting the reduced uncertainty from additional samples showed to be quite accurate in Sections 4.2.1 and 4.3.1.1. Predictions of uncertainty reduction are necessary to determine the VOI.

The second underlying objective is necessary for the risk assessment process to evolve toward a more scientifically based methodology, as recommended by the National Research Council (NRC, 1983). For the evolution to continue, there must be a clear distinction between risk assessment, which is the scientific and objective procedure of estimating the risk, and risk management, which is the decision process of considering technical, social, economical, political, and other factors to determine a remediation strategy. Establishing an appropriate conservative point estimate value for the risk variables requires both science and policy.

The probabilistic risk assessment techniques presented in this research provide an objective method for the risk analyst to account for the uncertainty using distributions as opposed to conservative point estimates. This research also provides a methodology for estimating the uncertainty in the risk variables and propagating the uncertainty in each variable through the risk calculations to estimate the uncertainty in the final risk estimate. This offers a method to minimize the need for conservative assumptions and maintains a separation of science and policy. Variables that have not been researched in the literature or for which there is no data available may still need to be estimated using conservative assumptions, but as was shown in Section 3.7.9 of this research, those variables are

typically variables that are less influential and the conservative assumptions may not make a difference.

In order to move from one paradigm of risk analysis to another paradigm, there must be substantial benefits to be gained from the new methodology. The third objective was to present and validate the possible benefits from using the probabilistic risk assessment (PRA) approach. There are five possible benefits, that were shown and addressed throughout Chapters 3 demonstrated in Chapter 4, and summarized in Section 3.14, that can be gained from using the probabilistic risk assessment (PRA) approach over the current deterministic point estimate. First, the PRA approach maintains a better separation between risk assessment and risk management. The risk analyst can be objective about estimating the uncertainty in the risk variables and propagate that uncertainty through the risk calculations using the Monte Carlo method. This allows the risk analyst to objectively present all the information, and let the decision maker determine the level of conservatism in the risk value or risk percentile that is appropriate for the site. The second benefit stems from the first in that the PRA approach avoids the debate that exists in the literature over how conservative the risk variables must be to estimate the RME risk.

The third, fourth, and fifth benefits are distinct but tied together in that they allow for more analysis of the estimated risk to apply the tools and techniques necessary to accomplish the overall research objective. The third benefit of the PRA approach was that it provides a better method of estimating the uncertainty and variability in the final risk distribution. As was demonstrated in Section 3.13, it is important for the risk analyst to be

aware of which variables consist primarily of variability or uncertainty and which ones contribute the most to the overall variance of the risk distribution. If the difference between uncertainty and variability is not considered, resources may be expended in efforts to reduce an irreducible natural variability or to marginally reduce the uncertainty.

The fourth benefit is the wealth of information that is provided from a probabilistic risk assessment above that of a point estimate. Figure 5-1 shows what is typically given to a decision maker in the point estimate approach (Thompson *et al.*, 1994:58). The risk analyst provides the decision maker with an RME point estimate of the risk, represented by the black point on the continuum of risks in Figure 5-1. The risk analyst knows the RME risk is a conservative estimate of the high end of the risk distribution, but is unable to answer the question of how conservative the point estimate might be or the likelihood that it might actually occur within the population of concern.

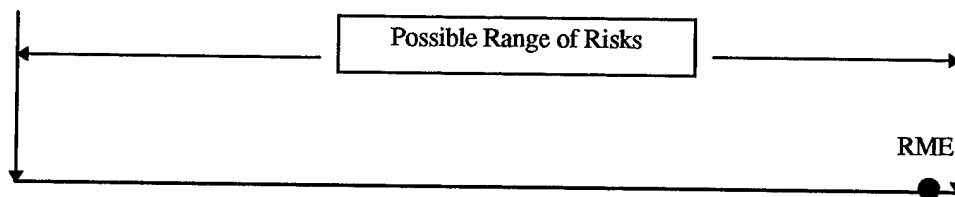

Figure 5-1: Information Typically Provided From Deterministic Point Estimate Approach

As discussed in Section 2.3.4, the EPA recognizes that a point estimate of the risk is both misleading and incomplete (USEPA, 1992b:16) because all the uncertainties in the risk variables used to estimate the RME risk point estimate cannot be adequately represented by a single point. Figure 5-2 shows a general probability density function of the range of risks that can be generated using a probabilistic risk assessment approach.

The distribution provides much more information about the possible range of risks and an estimate of the likelihood that the risks will occur. The RME point estimate shown in Figure 5-1 is provided in Figure 5-2 to show that the decision maker can be given an estimate of the likelihood of any risk along the range or risk, including the RME point estimate.

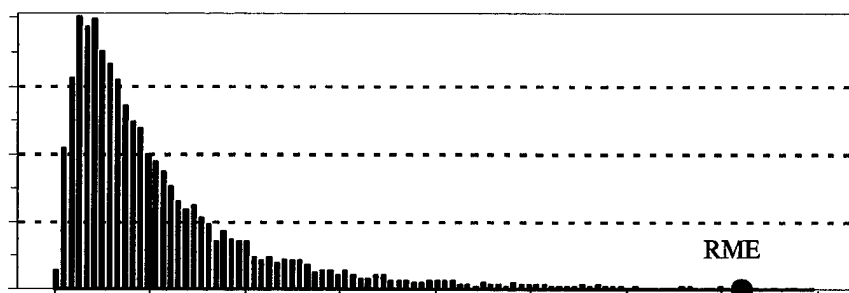

Figure 5-2: General Probability Density Function for a Range of Risks

The risk distribution graphs, statistics, percentiles, and sensitivity analysis charts provided in Chapter 4 from a probabilistic risk assessment of the risks at OU2 and Site 4 provide information that is critical to both the analyst and the decision maker. This information would be impossible to attain using the point estimate approach. Unless uncertainty and variability in both the risk variables and the risk estimate are quantified, it is difficult to make optimal decisions to maximize the benefit to cost ratio of resources expended during the investigation. The fifth benefit is that the analyst is not bound to Clairmont's analysis of a risk distribution for one chemical in one media. The methodology is flexible in that it can estimate a chemical-specific risk distribution, as shown for OU2 in Section 4.2.2, or the total risk due to all chemicals in all media to the population of interest as shown for Site 4 in Section 4.3.2. It provides flexibility to meet

the specific needs of the analyst and decision maker. The five possible benefits of the methodology discussed above were tested and demonstrated in Chapter 4.

Thus far the three underlying objectives of this research have been reviewed. The purpose of the underlying objectives was to accomplish the main objective of this research, which was to aid the risk analyst and decision maker to more efficiently and objectively characterize the risk at a site. To accomplish this objective, there was a need for a decision support model to encompass the complexity of the remedial investigation and feasibility study (RI/FS). The decision support model also needed to determine, in an optimal manner, based on some decision maker preferences, whether additional information should be gathered or an appropriate remedial action could be recommended without additional information.

Clairmont developed a decision support model that accomplished the main objective, but he made some simplifying assumptions to estimate the risk distribution. This research evaluated some of these assumptions and found that they may not be appropriate for environmental data. Clairmont's uncertainty analysis of the risk distribution was limited to the final risk probabilities in the decision support model. Uncertainty analysis of the risk distribution and the presentation of this uncertainty analysis to the decision maker are both vital to the decision process. By providing a more appropriately assessed risk distribution, including uncertainty and variability analysis, the recommendations of the decision support model will be more credible when presented to a decision maker. The three underlying objectives of this research were all driven by a need to more appropriately assess the risk distributions which would be input into the decision

support models. The risk distribution along with the recommendations of the decision support model could be provided to the decision maker for consideration along with other social and political factors.

The use of the methodology along with Clairmont's models resulted in some key findings in Chapter 4 that support the assumptions of this research. By not considering VOI or the relative importance of the mean concentration, the marginal returns of reducing the uncertainty in the mean concentration and the risk were gained at a considerable and possibly unnecessary cost. In the case of OU2 the marginal reduction in the uncertainties of the mean concentration (shown in Appendix B) and the estimated risk (shown in Figure 4-3, Figure 4-4, and Table 4-3), from the additional information from the RI100% were gained at an expected cost of \$240,000 (in 1996 dollars). In the case of Site 4 the marginal reduction in the uncertainty of the mean concentrations (shown in Appendix B for each chemical) and the estimated risk (shown in Figure 4-12, Figure 4-13, Table 4-6) were gained at an estimated cost of \$200,000 (in 1996 dollars). This seems like a high price to pay for such a marginal reduction in the uncertainty of the risk. A price that may no longer be affordable in the future.

5.2 Recommendation for Further Research

There are certain areas of this research that may be potential issues of further research. In this research, a lower limit of 10 samples was used to estimate the distribution of the a pollutant in the environment. This was based on the minimum requirement of ExpertFit. Some analysis could be done to determine an optimal level of samples specific to environmental data that are required to begin estimating the

distribution. The analysis of contribution to variance used in this research is only an approximation. There may be other methods of analytically estimating the contribution to variance, such as linear regression, that were beyond the scope of this research. In evaluating the two sites in this research the author speculated a trend that may exist. Contractors are typically hired by the Air Force to do risk assessments. Some of the assumptions made by these contractors in assessing the risks seemed to be ultra conservative. Because the contractor does not bear the cost of clean-up, it is to the contractors benefit to use every conservative assumption that can be reasonably justified to estimate the risk. By using more conservative assumptions, the contractor is more confident that their assessment has not improperly characterized the risk present at the site. Unfortunately, for the Air Force, as the number of conservative assumptions used increases so does the likelihood that sites are being cleaned up unnecessarily. It might be valuable to the Air Force to evaluate a number of risk assessments done by contractors to see if other overly conservative assumptions are being made by contractors who may benefit from conservative assumptions.

Appendix A

The following are the calculations for the 95% upper bound confidence limit (UBCL) of the mean concentration with 14 samples from the POL area after the RI70%. The calculations were done in Mathcad 6.0 Plus (MathSoft, 1995) and imported into a Word document.

The 14 samples and pertinent statistics are as follows:

$$\text{BnData14} := (.002 \ .075 \ .051 \ .002 \ .120 \ .100 \ .044 \ .053 \ .500 \ .002 \ .039 \ .280 \ .002 \ .023)$$

$$\text{Sample_Mean} := \text{mean}(\text{BnData14}) \qquad \text{Sample_Mean} = 0.0924$$

$$\text{Sample_Variance} := \frac{\text{var}(\text{BnData14}) \cdot n}{n - 1} \qquad \text{Sample_Variance} = 0.0191$$

$$\text{Sample_Stan_Dev} := \sqrt{\text{Sample_Variance}} \qquad \text{Sample_Stan_Dev} = 0.1382$$

$$\text{StanErr} := \frac{\text{Sample_Stan_Dev}}{\sqrt{n}} \qquad \text{StanErr} = 0.0369$$

The 95% UBCL assuming the mean concentration is both normally and lognormally distributed were calculated.

Assuming the mean concentration is normally distributed

$$t_{95} := \text{qt}(.975, n - 1) \qquad t_{95} = 2.1604$$

$$\text{UCL}_{x95} := \text{Sample_Mean} + \frac{t_{95} \cdot \text{Sample_Stan_Dev}}{\sqrt{n}} \qquad \text{UCL}_{x95} = 0.1722$$

Assuming the actual pollutant concentration is lognormally distributed. The following calculations are based on the recommended guideline procedures (USEPA, 1989c:Ch 6, 19) out of Gilbert (1987:170).

In order to calculate the estimate of the 95%UBCL the data must be lognormally transformed.

$$\text{Transformed_Data}_{1,i} := \ln(\text{BnData14}_{1,i})$$

$$\text{Sample_Mean}_T = -3.5636$$

$$\text{Sample_Variance}_T := \frac{\text{var}(\text{Transformed_Data}) \cdot n}{n - 1}$$

$$\text{Sample_Variance}_T = 3.6381$$

$$\text{Sample_Stan_Dev}_T := \sqrt{\text{Sample_Variance}_T}$$

$$\text{Sample_Stan_Dev}_T = 1.9074$$

The following is the H statistic discussed in Gilbert (1987).

$$H_{\text{upper95}} := 4.424$$

$$\text{Arithmetic_UBCL} := e^{\left(\text{Sample_Mean}_T + .5 \cdot \text{Sample_Variance}_T + \frac{\text{Sample_Stan_Dev}_T \cdot H_{\text{upper95}}}{\sqrt{n-1}} \right)}$$

$$\text{Arithmetic_UBCL} = 1.8125$$

The 95% UBCL assuming the mean concentration is normally distributed was used because the 95% UBCL using the calculations from Gilbert resulted in an excessively large 95% UBCL. The UBCL of 1.8125 mg/L is approximately 20 times greater than the sample mean of 0.0924 mg/L. Others have analyzed the methodology outline in Gilbert (1987) and have shown that this methodology may result in significant overestimation of the mean concentration (Burmester and Edelman, 1996).

Appendix B

All the values that were below the minimum detection limit (MDL) values in the sample set for all the chemicals analyzed were set at the MDL. This resulted in all the values in the sample set equal to or greater than the MDL, which biased the best fit distributions. Some of the better fitted distributions have location parameters that are heavily influenced by the fact that there were no values below the MDL. It was assumed that a distribution having the location parameter at zero would probably be a more reasonable distribution than one with the location parameter close to the MDL. This is why some of the less-than-best-fit distributions were used in the simulation.

1 Distributions for Benzene at OU2, WPAFB

ExpertFit Results			
Risk Simulation Distribution	Best-Fit Distribution	Rank	Score
ARI70%	Pearson Type 6 (0.00, 1.00, 0.56, 7.11)	1	89.47
	Gamma (1.03e-3, 0.20, 0.46)	2	86.84
	Gamma (0.17, 0.53)*	3	85.53
MRI70%	Erlang (0.00, 0.01, 8.00)	1	99.04
	Gamma (0.01, 7.61)*	2	97.12
PMRI70%	Gamma(7.97e-3, 11.58)*	1	100
ARI100%	Gamma (9.98e-4, 0.23, 0.35)	1	96.05
	Pearson Type 6 (9.97e-4, 1.00, 0.37, 5.32)	2	90.79
	Gamma (0.18, 0.47)*	3	81.58
MRI100%	Johnson SU (1.52e-3, 0.06, -4.28, 3.89)	1	100.00
	Erlang (0.00, 8.22e-3, 10.00)	2	95.19
	Gamma (8.64e-3, 9.53)*	3	93.27

* -- distribution used in probabilistic risk simulation

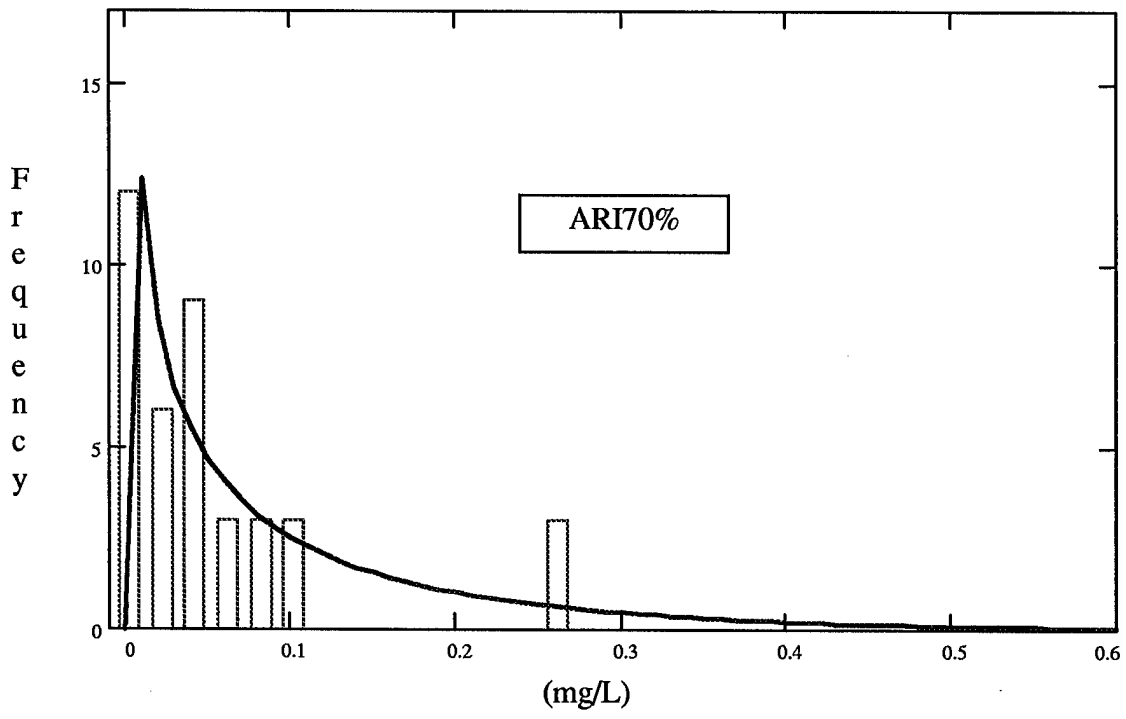

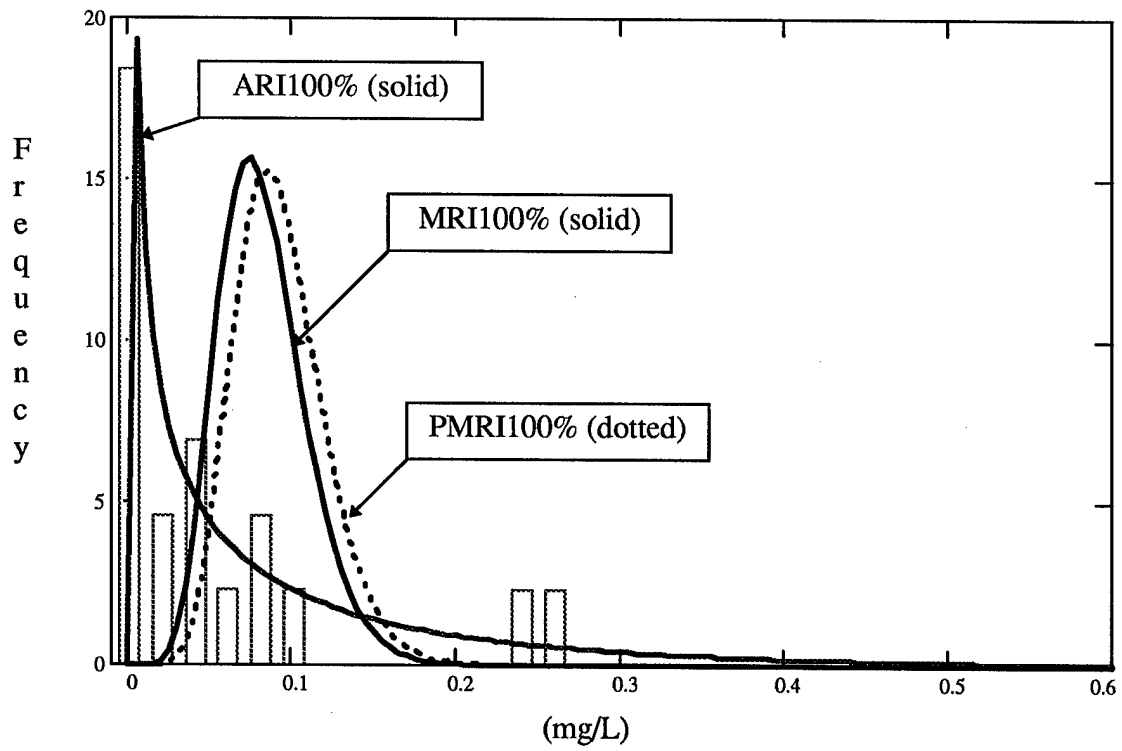
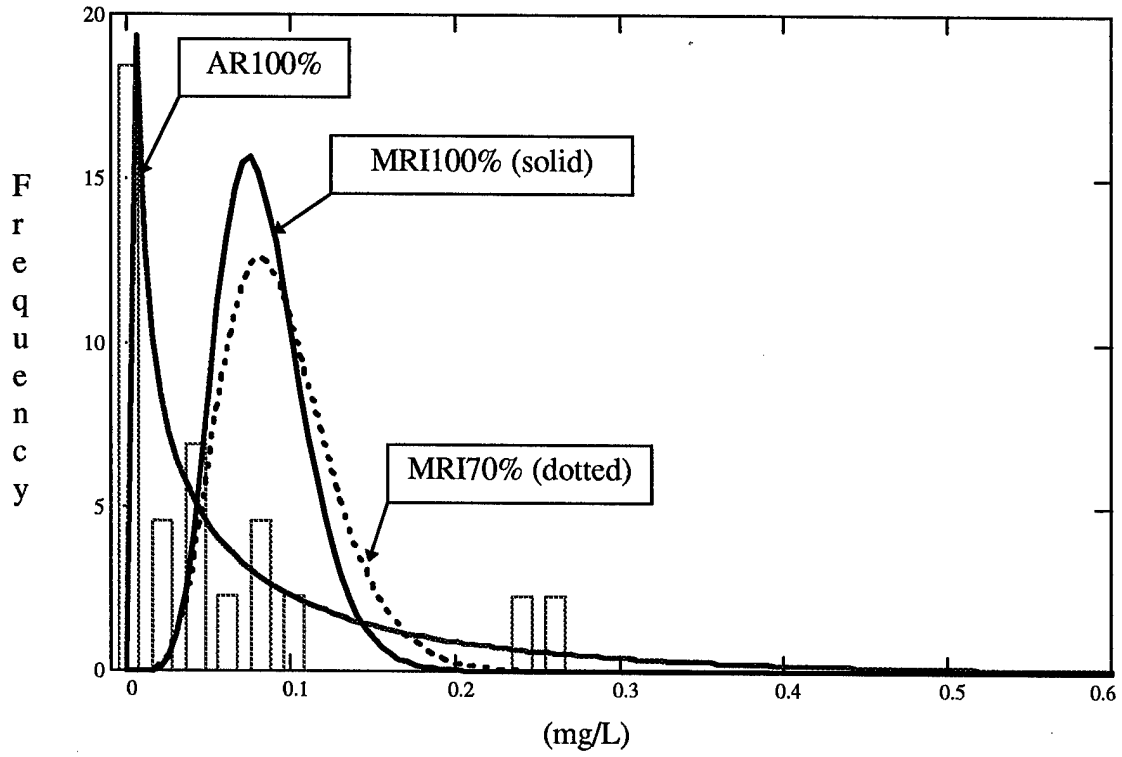

2. Distributions for Cadmium in Soil at Site 4, AFP44

	ExpertFit Results		
Risk Simulation Distribuiton	Best-Fit Distribution	Rank	Score
ARI70%	Weibull (0.25, 0.46, 0.28)	1	92.65
	Gamma (0.25, 22.88, 0.18)	2	91.18
	Lognormal (0.25, -2.69, 3.79)	3	85.29
	Lognormal (-0.16, 1.63)*	4	79.41
MRI70%	Log-Logistic (0.97, 1.82)	1	98.08
	Pearson Type (0.00, 17.72)	2	97.35
	Pearson Type 6 (0.00, 1.00, 24.55, 8.78)	3	91.00
	Lognormal (1.07, 0.41)*	5	81.00
PMRI70%	Johnson SU (1.78, 0.73, -1.60, 1.34)	1	97.12
	Pearson Type 5 (0.00, 23.64)	2	94.23
	Log-Logistic (1.21, 1.67, 2.69)	3	92.31
	Lognormal (1.10, 0.36)*	9	71.15
ARI100%	Gamma (0.25, 29.57, 0.18)	1	91.18
	Weibull (0.25, 0.58, 0.27)	2	89.71
	Lognormal (0.25, 0.58, 0.27)	3	82.35
	Lognormal (3.79e-3, 1.74)*	4 1/2	77.94
MRI100%	Johnson SU (2.21, 1.03, -1.77, 1.34)	1	100.00
	Pearson Type 5 (0.00, 26.14, 6.72)	2	92.31
	Log-Logistic (1.55, 2.46, 2.53)	3	90.38
	Lognormal (1.43, .41)*	7	75.96

* -- distribution used in probabilistic risk simulation

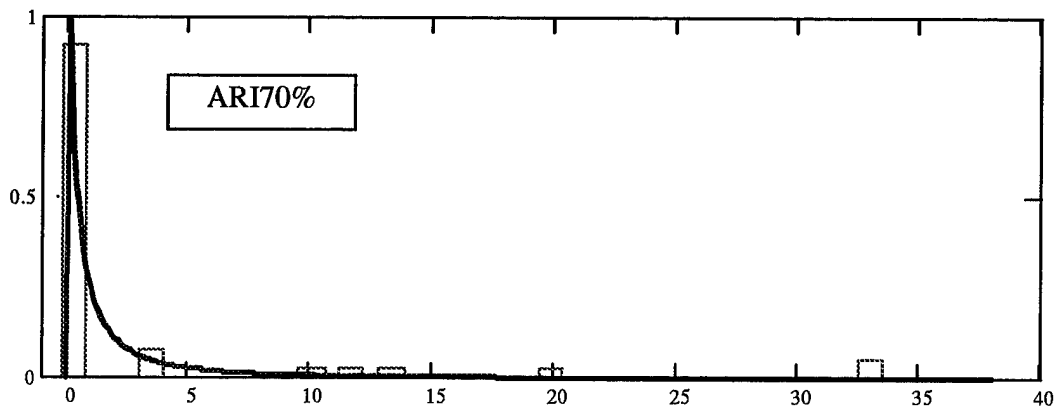

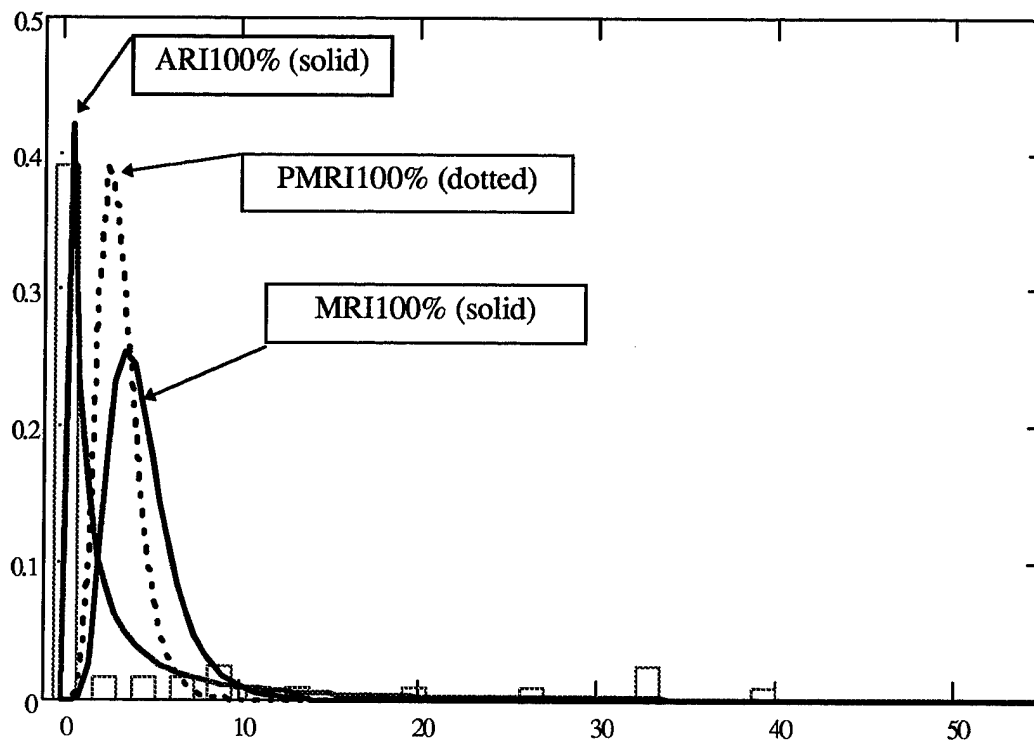
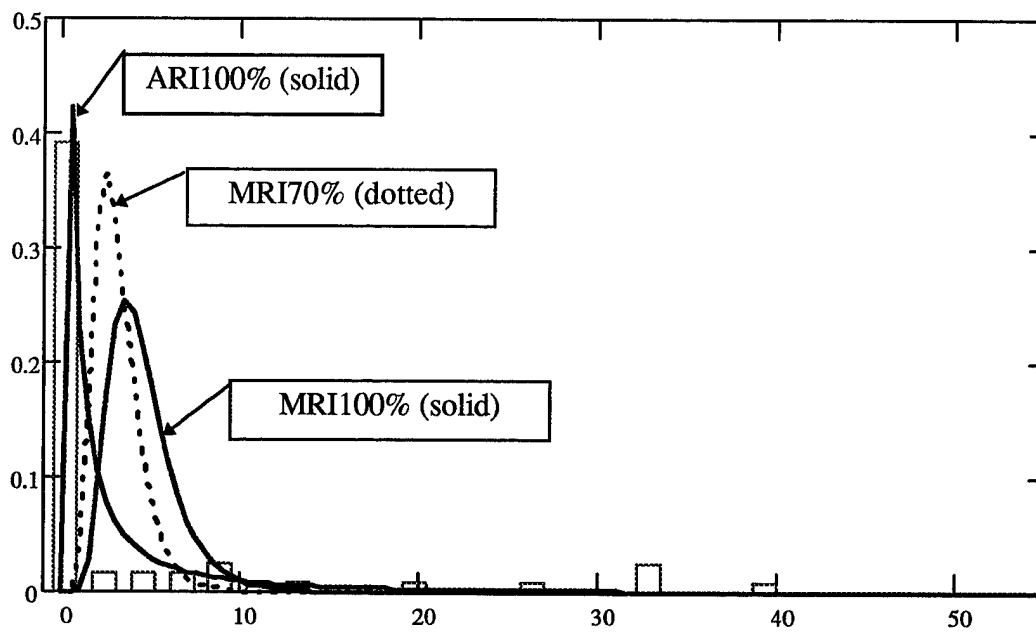

3. Distributions for Chromium in Soil at Site 4, AFP44

Risk Simulation Distribuiton	ExpertFit Results		
	Best-Fit Distribution	Rank	Score
ARI70%	Lognormal (6.29, 2.65, 2.90)	1	97.06
	Weibull (6.30, 50.94, 0.39)	2	97.06
	Lognormal (3.46, 1.63)*	3	85.29
MRI70%	Log-Logistic (37.55, 76.02, 2.64)	1	98.91
	Pearson Type 5 (639.69, 5.90)	2	96.74
	Log-Logistic (115, 4.11)	3	89.13
	Lognormal (4.77370, 43233)	5	82.61
PMRI70%	Log-Logistic (45.35, 71.54, 2.79)	1	100
	Pearson Type 5 (0.00, 858.49, 7.54)	2	92.71
	Inverted Weibull (0.00, 101.80, 3.02)	3	89.58
	Lognormal (4.81, 0.38)	8	71.88
ARI100%	Lognormal (6.30, 2.87, 2.77)	1	98.53
	Weibull (6.30, 63.06, 0.40)	2	95.59
	Inverse-Gaussian (326.69, 19.29)	3	86.76
	Lognormal (3.60, 1.71)	4	82.35
MRI100%	Johnson SU (75.42, 35.86, -1.90, 1.40)	1	100.00
	Pearson Type 5 (971.65, 7.14)	2	92.71
	Log-Logistic (55.47, 84.51, 2.58)	3	91.67
	Lognormal (4.99, 0.39)*	6	76.04

* -- distribution used in probabilistic risk simulation

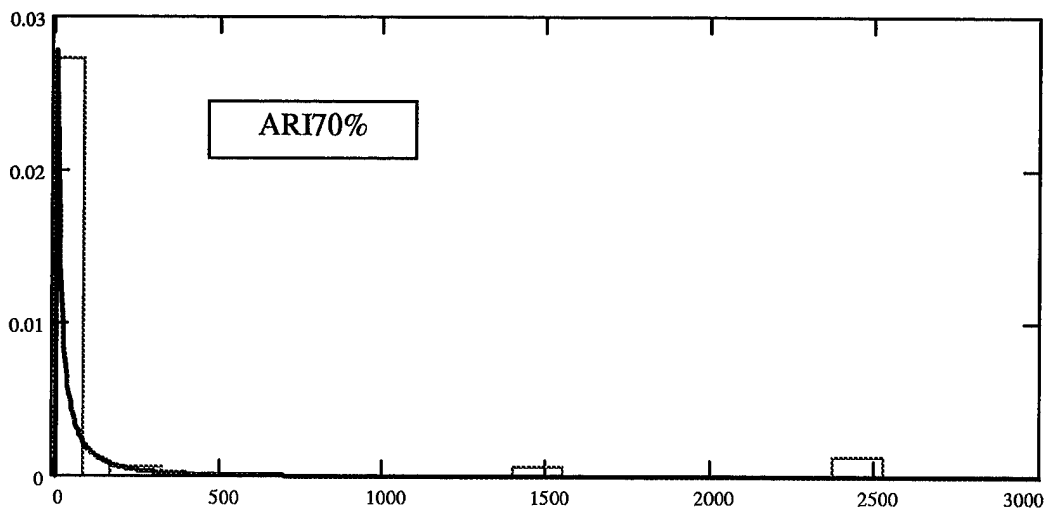

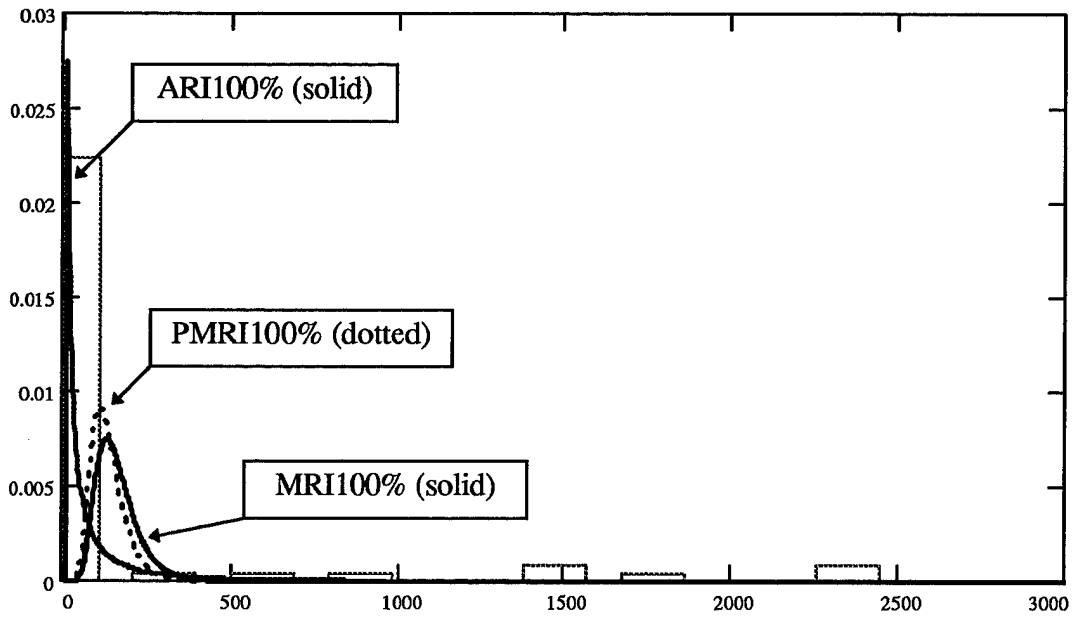
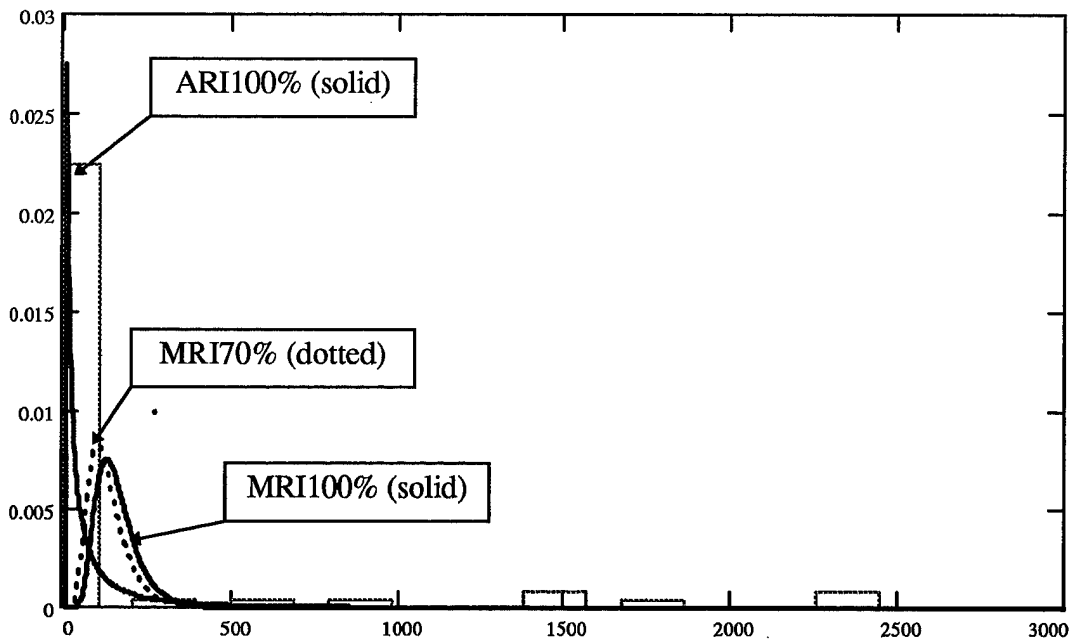

4. Distributions for Antimony in Soil at Site 4, AFP44

Risk Simulation Distribuiton	ExpertFit Results		
	Best-Fit Distribution	Rank	Score
ARI70%	Log-Logistic (-2.29, 5.52, 4.59)	1	83.93
	Log-Logistic (0.00, 3.16, 3.78)	2	81.25
	Log-Laplace (3.00, 3.78)	3 1/2	80.80
	Weibull (6.63, 0.74)*	5	85.29
MRI70%	Erlang (0.00, 0.33, 24)	1 1/2	98.15
	Gamma (0.33, 24.16)*	1 1/2	98.15
PMRI70%	Erlang (0.00, 0.21, 38.00)	1 1/2	98.21
	Gamma (0.20, 38.39)*	1 1/2	98.21
ARI100%	Log-Logistic (1.58, 1.58, 2.64)	1 1/2	81.25
	Weibull (1.58, 3.90, 0.65)	1 1/2	81.25
	Log-Logistic(0.00, 3.26, 3.38)	3	80.36
	Weibull (6.66, 0.80)*	6	76.79
MRI100%	Lognormal (2.01, 0.15)*	1	96.43

* -- distribution used in probabilistic risk simulation

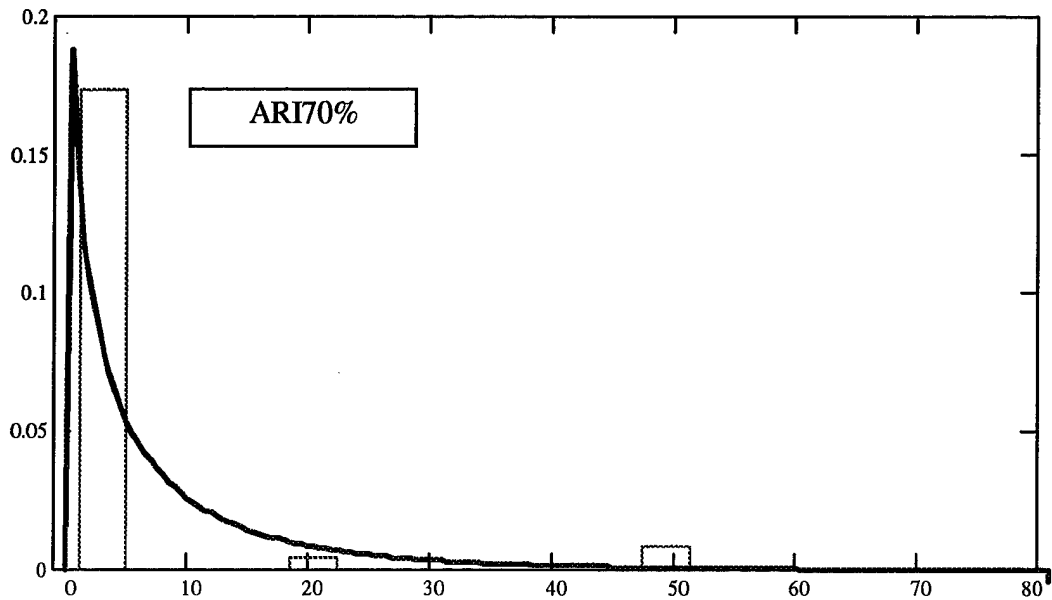

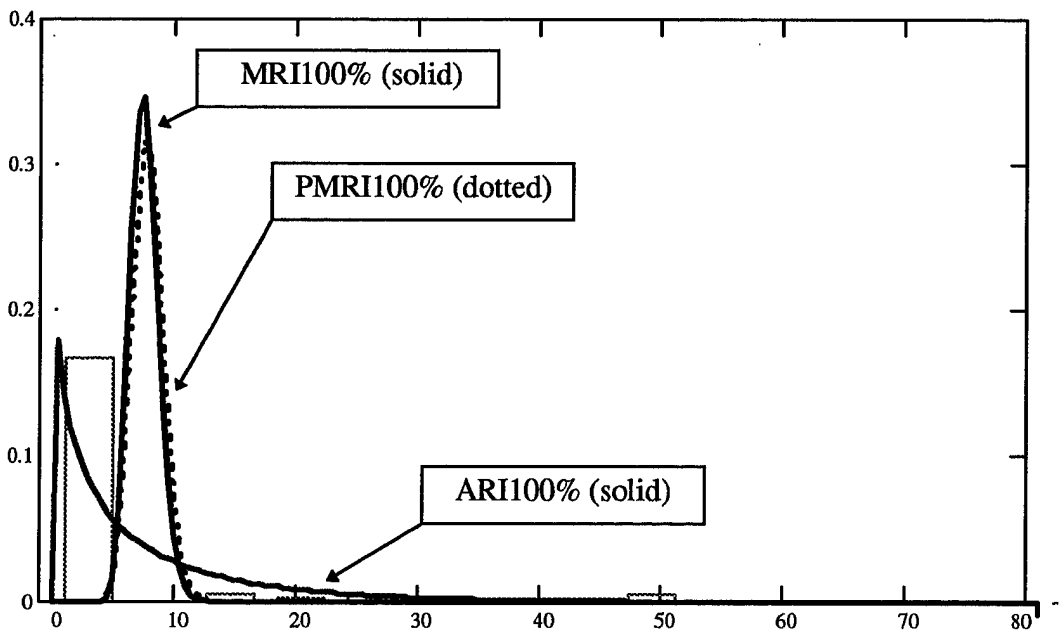
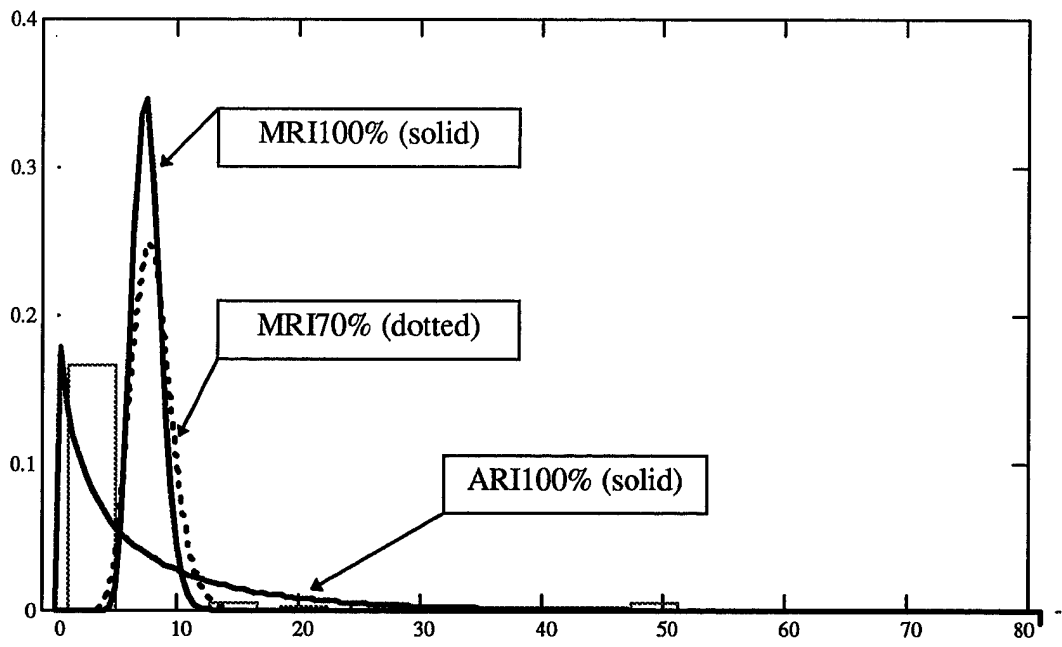

Appendix C

Determining the Relative Importance of Accurately Estimating the Uncertainty in the Mean Concentration

Some authors argue that environmental data is usually spatially and serially correlated, which results in an underestimation of the true variability of the contamination at a site (Banks, 1996:442). There is also an argument that standard statistical techniques used on a single data set reveal only a trivial portion of the uncertainty in the parameters being estimated (Hattis and Burmaster, 1994:726). Given that 14 biased samples are available from OU2 after the RI70%, both are valid arguments. The samples are biased in that the extraction wells are placed at suspected points of contamination. These arguments, however, must be considered in light of how important the estimate of the uncertainty of mean concentration is to the uncertainty of the final value being estimated. The following sensitivity analysis shows the minimal effect of possibly underestimating the uncertainty in the estimate of the mean concentration distribution for the OU2 scenario.

The function E-1 shows the best fit gamma distribution for benzene concentration (x) in the groundwater, where α is estimated as 0.53241 and β is estimated as 0.17347. The values are taken from the ARI70% distribution for benzene in Appendix B.

$$x \sim \text{Gamma}(\beta, \alpha) \quad (\text{E-1})$$

For a gamma distribution the mean is equal to $\alpha \cdot \beta$ and the standard deviation is equal to $\sqrt{\alpha \cdot \beta^2}$. Using these equations, the estimate of the mean, \bar{x} , and the estimate of the standard deviation, s_x , from the best fit gamma distribution are equal to 0.09236 (mg/L) and 0.1266 (mg/L) respectively. The mean and standard deviation from the 14 samples,

based on the analysis done in Appendix A, are 0.0923 (mg/L) and 0.1382 (mg/L) respectively. The results of the two estimates coincide and are used as a comparison to the simulated distribution of the uncertainty in the mean concentration below.

Function E-2 shows the best-fit gamma distribution for the uncertainty in the estimate of the mean concentration (\bar{x}) for benzene with 14 samples, which was simulated from ARI70% in Section 3.7.5.2. Where $\alpha_{\bar{x}}$ is estimated as 7.60837 and $\beta_{\bar{x}}$ is estimated as 0.01214, which are taken from the MRI70% distribution for benzene in Appendix B.

$$\bar{x} \sim \text{Gamma}(\beta_{\bar{x}}, \alpha_{\bar{x}}) \quad (\text{E-2})$$

The estimate of the mean (\bar{x}) and standard deviation ($s_{\bar{x}}$) of the optimally-fit distribution of uncertainty in the mean concentration are equal to 0.09237 (mg/L) and 0.03349 (mg/L). These results are consistent with the estimates of the distribution for "x." The distribution of the uncertainty in the estimate of the mean concentration is expected to have the same mean as "x" and a standard deviation approximately equal to the standard deviation of "x" divided by the square root of the number of samples, $\frac{0.1266}{\sqrt{14}}$, which equals 0.03384 (mg/L).

It is argued though, that because of serial correlation and a small sample size, the estimate s_x has underestimated the true value σ_x . Subsequently, the estimate $s_{\bar{x}}$ has underestimated the true value of $\sigma_{\bar{x}}$, which is the value of interest in the risk simulation. The question is, how does this possible underestimation effect the estimate of the risk

distribution? Figure E-1 shows three gamma distributions with the same mean of 0.0924 mg/L a standard deviation of $s_{\bar{x}}$, 2 times $s_{\bar{x}}$, and 3 times $s_{\bar{x}}$.

If $s_{\bar{x}}$ underestimates $\sigma_{\bar{x}}$, it was assumed that it would not underestimate it by more than a factor of 2 as shown by the dashed gamma distribution in Figure E-1. If the value of $s_{\bar{x}}$ underestimates the true value of $\sigma_{\bar{x}}$ by a factor of 3, then the value of $s_{\bar{x}}$ would be close to the value of s_x of 0.1265 mg/L. This distribution, as shown by the dotted line in Figure E-1 would look similar to the actual benzene concentration, ARI700% in Appendix B, which is probably not the case. Assuming that the distribution for the uncertainty in the mean concentration would have a standard deviation of 4 or greater assumes that \bar{x} has a greater standard deviation than "x," which is inconsistent with the laws of statistics.

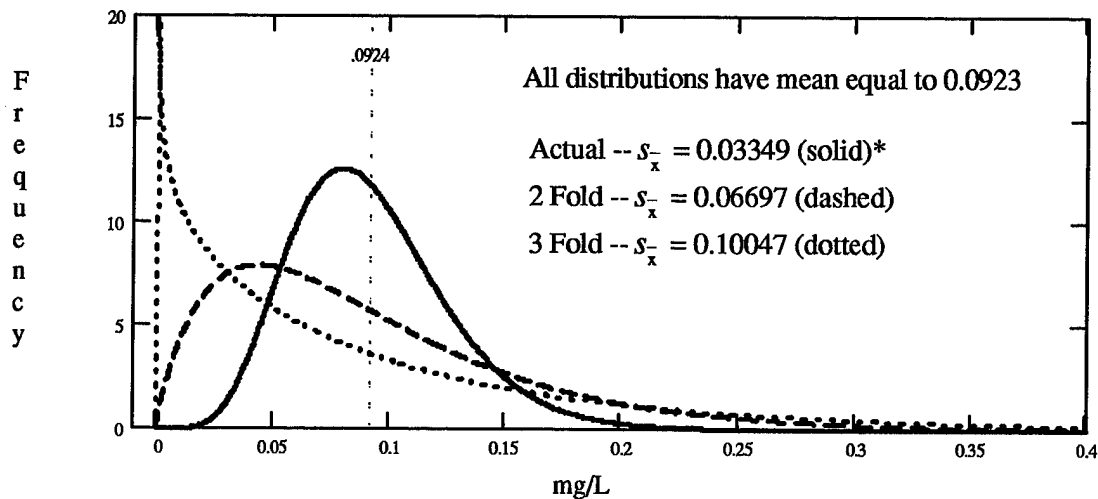

Figure E-1: Range of Possible Gamma Distributions for \bar{x} If $\sigma_{\bar{x}}$ is Underestimated

* -- distribution used in the RI70% risk simulation

To conduct some sensitivity analysis of the estimate of $\sigma_{\bar{x}}$, the three mean concentration distributions shown in Figure E-1 were input into the risk simulation to

estimate the effects of underestimating the uncertainty in the mean concentration. The risk distribution generated from the solid gamma mean concentration distribution will be called the RI70% risk distribution because it was the actual distribution used in the probabilistic risk assessment simulation. The other two risk distributions will be called RI70%-2 s_x and RI70%-3 s_x for a 2 and 3 fold overestimation of s_x respectively and are used only for this sensitivity analysis. Figure E-2 and E-3 show the RI70%-2 s_x and RI70%-3 s_x risk distributions. Comparing the RI70%-2 s_x and RI70%-3 s_x risk distributions in Figure E-2 and E-3 to the actual RI70% risk distribution in Figure 3-12, a significant difference between the three is not obvious.

The only way to accurately compare the three distributions is to compare some key percentiles, statistics, and the risk probabilities for the three risk distributions, which are provided in Tables E-1 and E-2. The results in Tables E-1 and E-2 show that even if the uncertainty in the estimate of the mean concentration is underestimated, the risk distribution will not significantly change.

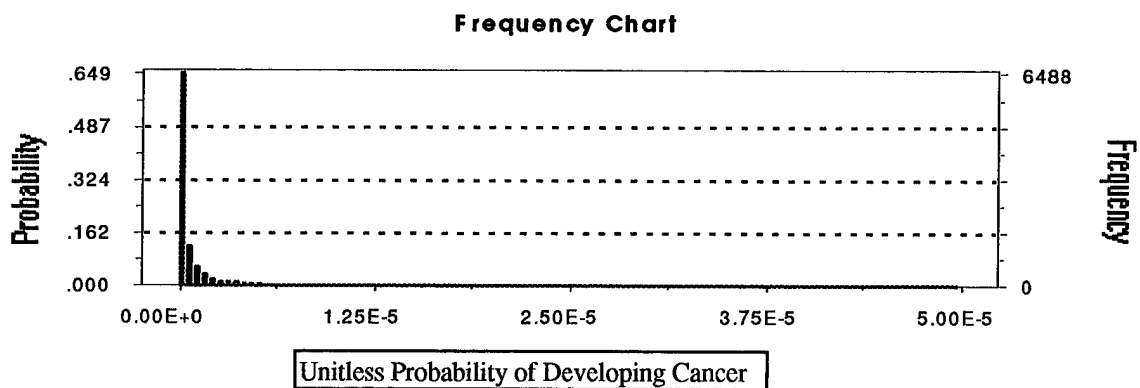

Figure E-2: RI70%-2 s_x Risk Distribution

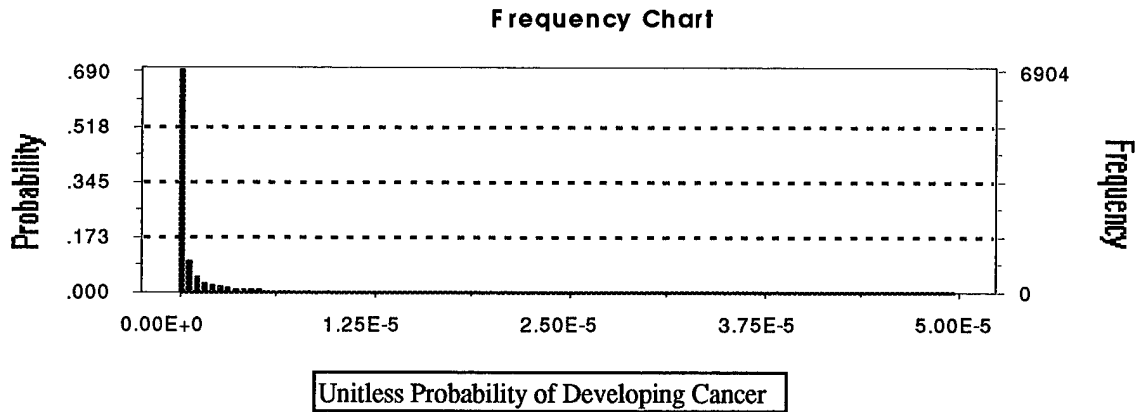

Figure E-3: RI70%-3 s_x Risk Distribution

Table E-1: Selected Percentiles From Sensitivity Analysis of s_x

Percentiles	50%	60%	70%	80%	90%	95%	Max Value
RI70%	2.93E-7	4.56E-7	7.34E-7	1.32E-6	3.19E-6	6.57E-6	9.85E-5
RI70%-2 s_x	1.69E-7	2.92E-7	5.35E-7	1.09E-6	2.83E-6	6.11E-6	3.29E-4
RI70%-3 s_x	2.41E-7	3.83E-7	6.65E-7	1.25E-6	3.04E-6	6.19E-6	2.06E-4

Table E-2: Key Statistics From Sensitivity Analysis of s_x

Simulation	Percentiles			Risk Probabilities		
	CA	CUA	RME PE	Low	Med	High
RI70%	62.08%	98.77%	98.04%	0.6208	0.3669	0.0123
RI70%-2 s_x	64.88%	99.83%	98.87%	0.6488	0.3495	0.0017
RI70%-3 s_x	69.04%	99.67%	98.91%	0.6904	0.3063	0.0033

The results of the sensitivity analysis show that the overestimation of σ_x results in a higher likelihood for the smaller values of the risk distribution. There is a greater probability that the risk is low, or in other words acceptable, and a lesser probability that the risk is medium or high, or in other words unacceptable, as shown in Table E-2. The concept of risk probabilities was discussed in Section 2.6.2.3. It is assumed that the

decision maker would prefer a greater probability of the risk being acceptable and a lesser probability that the risks are unacceptable. The possible underestimation of $\sigma_{\bar{x}}$ slightly biases the risk distribution high, which is better than slightly biasing it low from a liabilities viewpoint. In essence the effect of possibly underestimating the uncertainty in the estimate of the mean concentration due to serial correlation and a small sample size results in a more conservative estimate of the risk distribution. Thus, the effects of serial correlation and small samples sizes may be a possible benefit. This is due to the fact that the influence of the distribution of the uncertainty in the mean concentration on the overall risk distribution is minor compared to other more influential risk variables. This effect is thoroughly discussed and analyzed in Section 4.4.

These conclusions are specific to this scenario and should be accomplished when conducting a probabilistic risk assessment. They are important from both an estimating point of view and when using the estimate to predict the reduction in the uncertainty as in Section 3.12.2.

This section is provided for clarity so the user may keep track of the specific media and chemical types while running the model.

Input the name of MEDIA: *Groundwater*

Input the name of CHEMICAL: *Benzene*

This section contains the general parameters included in the model.

COST WEIGHT = 0.67

MAX COST = 6500000
MIN COST = 1500

MAX DURATION = 257.00
MIN DURATION = 0.50

PROBABILITY NFA COST IS **HIGH GIVEN RISK IS HIGH** = 1.000
 PROBABILITY NFA COST IS **HIGH GIVEN RISK IS IN THE MID RANGE** = 0.700
 PROBABILITY NFA COST IS **HIGH GIVEN RISK IS LOW** = 0.010

PROBABILITY NFA DURATION IS **LONG GIVEN RISK IS HIGH** = 1.000
 PROBABILITY NFA DURATION IS **LONG GIVEN RISK IS IN THE MID RANGE** = 0.700
 PROBABILITY NFA DURATION IS **LONG GIVEN RISK IS LOW** = 0.010

This portion of the spreadsheet contains the cost and duration values for the various stages of the characterization process. The cost is in dollars and the duration is in months only.

	COSTS			DURATIONS		
	Low	High	Expected Value	Low	High	Expected Value
Site Investigation	NA	NA	NA	NA	NA	NA
30% Remedial Investigation	NA	NA	NA	NA	NA	NA
60% Remedial Investigation	NA	NA	NA	NA	NA	NA
100% Remedial Investigation	700000	1100000	900000	5.000	10.000	7.500
Removal Action						
Media 1						
Media 2	10000	30000	20000	1.000	3.000	2.000
Media 3						
Feasibility Study	300000	400000	350000	6.000	8.000	7.000
Presumptive Remedy	20000	40000	30000	2.000	4.000	3.000
Recommend No Further Action	1500	3750000	NA	0.500	153.0	NA
Remediation Effort						
Media 1						
Media 2	100000	150000	125000	3.000	6.000	4.500
Media 3						

The following section contains the decision maker's inputs on the levels of acceptable and unacceptable levels of risk.

Values below which the cancer risk is CLEARLY ACCEPTABLE (i.e.: 10E-6) = 5.0E-07
 Values below which the hazard index is CLEARLY ACCEPTABLE (i.e.: 1.0) = 0.95
 Value above which the cancer risk is CLEARLY UNACCEPTABLE (i.e.: 10E-4) = 5.0E-05
 Values above which the hazard index is CLEARLY UNACCEPTABLE (i.e.: 1.0) = 1.05

The following section lists the probabilities associated with the feasibility study.

Probability the TRUE SITE CONDITION is SIMILAR to other sites is 0.5600

FEASIBILITY STUDY PROBABILITIES			
EVENT STATES	60% RI	100% RI	Removal Action
Site Similarity Report predicts similar given the true condition is similar	0.8000	0.9500	0.9800
Site Similarity Report predicts similar given the true condition is not similar	0.0500	0.0100	0.0100
Remedy technically acceptable given all remedies are investigated*			
Media 1			
Media 2	0.9900	0.9900	0.7000
Media 3			
Remedy technically acceptable given presumptive remedy is used and the site is similar			
Media 1			
Media 2	0.9500	0.9500	0.6000
Media 3			
Remedy technically acceptable given presumptive remedy is used and site is not similar**	0.000	0.000	0.000
Cleanup goal is met given the technology is acceptable***			
Media 1			
Media 2	0.9500	0.9800	0.6000
Media 3			
Cleanup goal is met given the technology is not acceptable****	0.0	0.0	0.0

- * Technically acceptable refers to the technology being appropriate for the type of contamination.
- ** The probability that the selected remedy is technically acceptable given that a presumptive remedy is used and the site is not similar is assumed to be constant for all decision points. This is because a presumptive remedy assumes that the site is similar. If the presumptive remedy is technically acceptable when the site is not similar to any other then it would have to be assumed to be a lucky outcome.
- *** These probabilities refer to the fact that the correct technology may be chosen but there is not enough information available to do a proper design. If the design is faulty the cleanup goal will not be met.
- **** The probability that the cleanup goal is met given that the technology is not acceptable is assumed to be constant for all decision points.

Factors associated with making the wrong decision during the feasibility study and relative to the no further action decision. They adjust the cost and duration associated with mistakes. See thesis text for more details.

Feasibility Study Adjustment Factors

Duration factor for a technically unacceptable remedy given all options were investigated	0.50
Cost factor for a technically unacceptable remedy given all options were investigated	0.50
Duration factor for a technically unacceptable remedy given a presumptive remedy was used	1.00
Cost factor for a technically unacceptable remedy given a presumptive remedy was used	1.00

Remediation Adjustment Factors

Duration factor given the technology was acceptable but did not meet the cleanup goals	1.40
Cost factor given the technology was acceptable but did not meet the cleanup goals	1.40
Duration factor given the technology was not appropriate	2.50
Cost factor given the technology was not appropriate	2.50

No Further Action Adjustment Factors

Duration factor for the high duration of the NFA alternative after an improper decision	1.50
Cost factor for the high cost of the NFA alternative after an improper decision	1.5

Unlike Clairmont's Model, the only risk parameters entered into the decision support model are the risk probabilities from the probabilistically assessed risk distribution.

70% Remedial Investigation

	Cancer Risk Probabilities				Hazard Index Probabilities			
	High	Middle	Low	NA	High	Middle	Low	NA
Type 1								
Media 1								
Media 2	4.90E-03	9.05E-02	9.05E-01	0.000	0.00E+00	0.00E+00	0.00E+00	1.000
Media 3								

100% Remedial Investigation

	Cancer Risk Probabilities				Hazard Index Probabilities			
	High	Middle	Low	NA	High	Middle	Low	NA
Type 1								
Media 1								
Media 2	2.60E-03	9.12E-02	9.62E-02	0.000	0.00E+00	0.00E+00	0.00E+00	1.000
Media 3								

This section is provided for clarity so the user may keep track of the specific media and chemical types while running the model.

Input the name of MEDIA: Groundwater

Input the name of CHEMICAL in MEDIA: Benzene

This section contains the general parameters included in the model.

COST WEIGHT = 0.67

MAX COST = 6500000

MAX DURATION = 257.00

MIN COST = 1500

MIN DURATION = 0.50

PROBABILITY NFA COST IS **HIGH GIVEN RISK IS HIGH** = 1.000

PROBABILITY NFA COST IS **HIGH GIVEN RISK IS IN THE MID RANGE** = 0.700

PROBABILITY NFA COST IS **HIGH GIVEN RISK IS LOW** = 0.010

PROBABILITY NFA DURATION IS **LONG GIVEN RISK IS HIGH** = 1.000

PROBABILITY NFA DURATION IS **LONG GIVEN RISK IS IN THE MID RANGE** = 0.700

PROBABILITY NFA DURATION IS **LONG GIVEN RISK IS LOW** = 0.010

This portion of the spreadsheet contains the cost and duration values for the various stages of the characterization process. The cost is in dollars and the duration is in months only.

	COSTS			DURATIONS		
	Low	High	Expected Value	Low	High	Expected Value
Feasibility Study	300000	400000	350000	6.000	8.000	7.000
Presumptive Remedy	20000	40000	30000	2.000	4.000	3.000
Recommend No Further Action	1500	2100000	NA	0.500	138.0	NA
Remediation Effort						
Media 1						
Media 2	100000	150000	125000	3.000	6.000	4.500
Media 3						

The following section contains the decision maker's inputs on the levels of acceptable and unacceptable levels of risk.

Values below which the cancer risk is CLEARLY ACCEPTABLE (i.e.: 10E-6) = 5.0E-07
 Values below which the hazard index is CLEARLY ACCEPTABLE (i.e.: 1.0) = 0.95
 Value above which the cancer risk is CLEARLY UNACCEPTABLE (i.e.: 10E-4) = 5.0E-05
 Values above which the hazard index is CLEARLY UNACCEPTABLE (i.e.: 1.0) = 1.05

The following section lists the probabilities associated with the feasibility study.

Probability the TRUE SITE CONDITION is SIMILAR to other sites is 0.5600

FEASIBILITY STUDY PROBABILITIES		
EVENT STATES	100% RI	
Site Similarity Report predicts similar given the true condition is similar	0.9500	
Site Similarity Report predicts similar given the true condition is not similar	0.0100	
Remedy technically acceptable given all remedies are investigated*	Media 1	
	Media 2	0.9900
	Media 3	
Remedy technically acceptable given presumptive remedy is used and the site is similar	Media 1	
	Media 2	0.9500
	Media 3	
Remedy technically acceptable given presumptive remedy is used and site is not similar**	0.000	
Cleanup goal is met given the technology is acceptable***	Media 1	
	Media 2	0.9800
	Media 3	
Cleanup goal is met given the technology is not acceptable****	0.0	

* Technically acceptable refers to the technology being appropriate for the type of contamination.
 ** The probability that the selected remedy is technically acceptable given that a presumptive remedy is used and the site is not similar is assumed to be constant for all decision points. This is because a presumptive remedy assumes that the site is similar. If the presumptive remedy is technically acceptable when the site is not similar to any other then it would have to be assumed to be a lucky outcome.
 *** These probabilities refer to the fact that the correct technology may be chosen but there is not enough information available to do a proper design. If the design is faulty the cleanup goal will not be met.
 **** The probability that the cleanup goal is met given that the technology is not acceptable is assumed to be constant for all decision points.

This section is provided for clarity so the user may keep track of the specific media and chemical types while running the model.

Complete Risk Distribution to Commercial Worker at AFP44 Site 4

Media of Contamination: Surface Soil

This section contains the general parameters included in the model.

COST WEIGHT = 0.67

MAX COST = 6500000
MIN COST = 1500

MAX DURATION = 257.00
MIN DURATION = 0.50

PROBABILITY NFA COST IS **HIGH GIVEN RISK IS HIGH** = 1.000
 PROBABILITY NFA COST IS **HIGH GIVEN RISK IS IN THE MID RANGE** = 0.700
 PROBABILITY NFA COST IS **HIGH GIVEN RISK IS LOW** = 0.010

PROBABILITY NFA DURATION IS **LONG GIVEN RISK IS HIGH** = 1.000
 PROBABILITY NFA DURATION IS **LONG GIVEN RISK IS IN THE MID RANGE** = 0.700
 PROBABILITY NFA DURATION IS **LONG GIVEN RISK IS LOW** = 0.010

This portion of the spreadsheet contains the cost and duration values for the various stages of the characterization process. The cost is in dollars and the duration is in months only.

	COSTS			DURATIONS		
	Low	High	Expected Value	Low	High	Expected Value
Site Investigation	NA	NA	NA	NA	NA	NA
30% Remedial Investigation	NA	NA	NA	NA	NA	NA
60% Remedial Investigation	NA	NA	NA	NA	NA	NA
100% Remedial Investigation	200000	250000	225000	5.000	10.000	7.500
Removal Action						
Soil	10000	30000	20000	1.000	3.000	2.000
Feasibility Study	300000	400000	350000	6.000	8.000	7.000
Presumptive Remedy	20000	40000	30000	2.000	4.000	3.000
Recommend No Further Action	2000	2100000	NA	0.500	153.0	NA
Remediation Effort						
Soil	100000	150000	125000	3.000	6.000	4.500

The following section contains the decision maker's inputs on the levels of acceptable and unacceptable levels of risk.

Values below which the hazard index is CLEARLY ACCEPTABLE (i.e.: 1.0) = 1.00

Values above which the hazard index is CLEARLY UNACCEPTABLE (i.e.: 1.0) = 1.00

Factors associated with errors during the making the wrong decision during the feasibility study and relative to the no further action decision. They adjust the cost and duration associated with mistakes. See thesis text for more details.

Feasibility Study Adjustment Factors

Duration factor for a technically unacceptable remedy given all options were investigated	0.50
Cost factor for a technically unacceptable remedy given all options were investigated	0.50
Duration factor for a technically unacceptable remedy given a presumptive remedy was used	1.00
Cost factor for a technically unacceptable remedy given a presumptive remedy was used	1.00

Remediation Adjustment Factors

Duration factor given the technology was acceptable but did not meet the cleanup goals	1.40
Cost factor given the technology was acceptable but did not meet the cleanup goals	1.40
Duration factor given the technology was not appropriate	2.50
Cost factor given the technology was not appropriate	2.50

No Further Action Adjustment Factors

Duration factor for the high duration of the NFA alternative after an improper decision=	1.50
Cost factor for the high cost of the NFA alternative after an improper decision=	1.5

Unlike Clairmont's Model, the only risk parameters entered into the decision support model are the risk probabilities from the probabilistically assessed risk distribution.

100% Remedial Investigation

		Cancer Risk Probabilities				Hazard Index Probabilities			
		High	Middle	Low	NA	High	Middle	Low	NA
Type 1									
	Media 2	2.40E-03	8.84E-02	9.09E-01	0.00E+00	0.00E+00	0.00E+00	0.00E+00	1.000

The following section lists the probabilities associated with the feasibility study.

Probability the TRUE SITE CONDITION is SIMILAR to other sites is 0.5600

FEASIBILITY STUDY PROBABILITIES			
EVENT STATES	60% RI	100% RI	Removal Action
Site Similarity Report predicts similar given the true condition is similar	0.8000	0.9500	0.9800
Site Similarity Report predicts similar given the true condition is not similar	0.0500	0.0100	0.0100
Remedy technically acceptable given all remedies are investigated*			
Soil	0.9900	0.9900	0.7000
Remedy technically acceptable given presumptive remedy is used and the site is similar			
Soil	0.9500	0.9500	0.6000
Remedy technically acceptable given presumptive remedy is used and site is not similar**	0.000	0.000	0.000
Cleanup goal is met given the technology is acceptable***			
Soil	0.9500	0.9800	0.6000
Cleanup goal is met given the technology is not acceptable****	0.0	0.0	0.0

- * Technically acceptable refers to the technology being appropriate for the type of contamination.
- ** The probability that the selected remedy is technically acceptable given that a presumptive remedy is used and the site is not similar is assumed to be constant for all decision points. This is because a presumptive remedy assumes that the site is similar. If the presumptive remedy is technically acceptable when the site is not similar to any other then it would have to be assumed to be a lucky outcome.
- *** These probabilities refer to the fact that the correct technology may be chosen but there is not enough information available to do a proper design. If the design is faulty the cleanup goal will not be met.
- **** The probability that the cleanup goal is met given that the technology is not acceptable is assumed to be constant for all decision points.

Factors associated with errors during the making the wrong decision during the feasibility study and relative to the no further action decision. They adjust the cost and duration associated with mistakes. See thesis text for more details.

Feasibility Study Adjustment Factors

Duration factor for a technically unacceptable remedy given all options were investigated	0.50
Cost factor for a technically unacceptable remedy given all options were investigated	0.50
Duration factor for a technically unacceptable remedy given a presumptive remedy was used	1.00
Cost factor for a technically unacceptable remedy given a presumptive remedy was used	1.00

Remediation Adjustment Factors

Duration factor given the technology was acceptable but did not meet the cleanup goals	1.40
Cost factor given the technology was acceptable but did not meet the cleanup goals	1.40
Duration factor given the technology was not appropriate	2.50
Cost factor given the technology was not appropriate	2.50

No Further Action Adjustment Factors

Duration factor for the high duration of the NFA alternative after an improper decision=	1.50
Cost factor for the high cost of the NFA alternative after an improper decision=	1.5

Unlike Clairmont's Model, the only risk parameters entered into the decision support model are the risk probabilities from the probabilistically assessed risk distribution.

70% Remedial Investigation

	Cancer Risk Probabilities				Hazard Index Probabilities			
	High	Middle	Low	NA	High	Middle	Low	NA
Comm Worker	0.0000	0.00E+00	0.00E+00	1.00E+00	0.0095	0.00E+00	9.91E-01	0.0000

100% Remedial Investigation

	Cancer Risk Probabilities				Hazard Index Probabilities			
	High	Middle	Low	NA	High	Middle	Low	NA
Comm Worker	0.0000	0.00E+00	0.00E+00	1.00E+00	0.0071	0.00E+00	9.93E-01	0.000

Removal Action

	Cancer Risk Probabilities				Hazard Index Probabilities			
	High	Middle	Low	NA	High	Middle	Low	NA
Comm Worker	0.0000	0.00E+00	0.00E+00	1.00E+00	0.0095	0.00E+00	9.91E-01	0.000

This section is provided for clarity so the user may keep track of the specific media and chemical types while running the model.

Complete Risk Distribution to Commercial Worker at AFP44 Site 4

Media of Contamination: Surface Soil

This section contains the general parameters included in the model.

COST WEIGHT = 0.67

MAX COST = 6500000
MIN COST = 1500

MAX DURATION = 257.00
MIN DURATION = 0.50

PROBABILITY NFA COST IS **HIGH GIVEN RISK IS HIGH** = 1.000
 PROBABILITY NFA COST IS **HIGH GIVEN RISK IS IN THE MID RANGE** = 0.700
 PROBABILITY NFA COST IS **HIGH GIVEN RISK IS LOW** = 0.010

PROBABILITY NFA DURATION IS **LONG GIVEN RISK IS HIGH** = 1.000
 PROBABILITY NFA DURATION IS **LONG GIVEN RISK IS IN THE MID RANGE** = 0.700
 PROBABILITY NFA DURATION IS **LONG GIVEN RISK IS LOW** = 0.010

This portion of the spreadsheet contains the cost and duration values for the various stages of the characterization process. The cost is in dollars and the duration is in months only.

	COSTS			DURATIONS		
	Low	High	Expected Value	Low	High	Expected Value
Feasibility Study	300000	400000	350000	6.000	8.000	7.000
Presumptive Remedy	20000	40000	30000	2.000	4.000	3.000
Recommend No Further Action	2000	2100000	NA	1.000	138.0	NA
Remediation Effort						
Media 1	750000	0	375000	60.000	0.000	30.000
Media 2	100000	150000	125000	3.000	6.000	4.500
Media 3	200000	0	100000	6.000	0.000	3.000

The following section lists the probabilities associated with the feasibility study.

Probability the TRUE SITE CONDITION is SIMILAR to other sites is 0.5600

FEASIBILITY STUDY PROBABILITIES	
EVENT STATES	100% RI
Site Similarity Report predicts similar given the true condition is similar	0.9500
Site Similarity Report predicts similar given the true condition is not similar	0.0100
Remedy technically acceptable given all remedies are investigated*	
	Soil 0.9900
Remedy technically acceptable given presumptive remedy is used and the site is similar	
	Soil 0.9500
Remedy technically acceptable given presumptive remedy is used and site is not similar**	0.000
Cleanup goal is met given the technology is acceptable***	
	Soil 0.9800
Cleanup goal is met given the technology is not acceptable****	0.0

* Technically acceptable refers to the technology being appropriate for the type of contamination.

** The probability that the selected remedy is technically acceptable given that a presumptive remedy is used and the site is not similar is assumed to be constant for all decision points. This is because a presumptive remedy assumes that the site is similar. If the presumptive remedy is technically acceptable when the site is not similar to any other then it would have to be assumed to be a lucky outcome.

*** These probabilities refer to the fact that the correct technology may be chosen but there is not enough information available to do a proper design. If the design is faulty the cleanup goal will not be met.

**** The probability that the cleanup goal is met given that the technology is not acceptable is assumed to be constant for all decision points.

Factors associated with errors during the making the wrong decision during the feasibility study and relative to the no further action decision. They adjust the cost and duration associated with mistakes. See thesis text for more details.

Feasibility Study Adjustment Factors

Duration factor for a technically unacceptable remedy given all options were investigated	0.50
Cost factor for a technically unacceptable remedy given all options were investigated	0.50
Duration factor for a technically unacceptable remedy given a presumptive remedy was used	1.00
Cost factor for a technically unacceptable remedy given a presumptive remedy was used	1.00

Remediation Adjustment Factors

Duration factor given the technology was acceptable but did not meet the cleanup goals	1.40
Cost factor given the technology was acceptable but did not meet the cleanup goals	1.40
Duration factor given the technology was not appropriate	2.50
Cost factor given the technology was not appropriate	2.50

No Further Action Adjustment Factors

Duration factor for the high duration of the NFA alternative after an improper decision=	1.50
Cost factor for the high cost of the NFA alternative after an improper decision=	1.5

This portion of the spreadsheet contains the probability of the risk posed by a particular chemical being clearly high, being clearly low, or being in the middle ground between the two points. The NA column is an indicator of the chemical effect the chemical. For example, under the cancer probabilities, if the probability of NA = 1.0, that particular chemical does not have a carcinogenic effect. If NA is 0.0 it indicates there is a carcinogenic effect and you will find probabilities listed in the High, Middle, and Low categories that sum to 1.0.

100% Remedial Investigation

	Cancer Risk Probabilities				Hazard Index Probabilities			
	High	Middle	Low	NA	High	Middle	Low	NA
Comm Worker	0.0000	0.00E+00	0.00E+00	1.00E+00	0.0093	0.00E+00	9.91E-01	0.000

Bibliography

- ADA Decision Systems. DPL Advanced Version User Guide. Belmont CA: Duxbury Press, 1995.
- Allen, Bruce C., Kenny S Crump and Annette M. Shipp. "Correlation Between Carcinogenic Potency of Chemicals in Animal Data," Risk Analysis vol. 8 no. 4. 531544 (1988).
- Averill M. Law & Associates. ExperFit Users's Guide. : Averill M. Law & Associates, 1995.
- Baird, Sandra J.S., Joshua T. Cohen, John D. Graham, Alexander I Shlyakhter, and John Evans. "Noncaner Risk Assessment: A Probabilistic Alternative to Current Practice," Human and Ecological Risk Assessment vol. 2 no. 1. 79-102 (1996).
- Banks, Jerry, John S. Carson, II, and Barry Nelson. Discrete-Event System Simulation (Second Edition). Upper Sadde River: Prentice Hall, 1996.
- Brainard, Jennifer. and David E. Burmaster. "Bivariate Distribution for Height and Weight of Men and Women in the United States," Risk Analysis vol. 12 no. 2. 267-275 (1992).
- Bredehoeft, J. D. "Hazardous Waste Remediation: A 21st Century Problem," GWMR: 95-100 (Winter 1994).
- Brown, Kenneth G., and Linda s Erdreich. "Statistical Uncertainties in the No-Observed-Adverse-Effect Level," Fundamentals of Applied Toxicology vol 13. 235-244 (1989).
- Burmaster, David E. and Paul D. Anderson. Principles of Good Practice for the Use of Monte Carlo Techniques in Human Health and Ecological Risk," Risk Analysis vol. 14 no. 4. 477-481 (1994).
- Burmaster, David E. and Jeanne W. Appling. "Introduction to Human Health Risk Assessment with an Emphasis on Contaminated Properties." Environmental Reporter-BNA. vol 25. no. 48. 2431-2440 (April 1995).
- Burmaster, David E. and Kristen G. Edelmann. "Estimating Exposure Point Concentration for Surface Soils for Use in Human Health Risk Assessments." submitted for publication to the Journal of Soil Contamination, 22 March 1996.
- Burmaster, David E and Katerine von Stackelberg. "Monte Carlo Simulations of Uncertainties in Risk Assessments of Superfund Using Crystal Ball," Environmental Engineering: Proceedings of the 1989 Specialty Conference. 10-12 July 1989. Austin.
- Burmaster, David E and Katerine von Stackelberg. "Using Monte Carlo Simulations in Public Health Risk Assessments: Estimating and Presenting Full Distributions of Risk," Journal of Exposure Analysis and Environmental Epidemiology vol. 1 no. 4. 491-512 (1991).

- Chen, Ling. "A Minimum Cost Estimator for the Mean of Positively Skewed Distributions with Applications to Estimation of Exposure to Contaminated Soils," Environmetrics vol. 6. 181-193 (1995).
- Clairmont, Daniel J. Decision Support Model to Optimize Site Characterization Activities Taken in Compliance with the Comprehensive Environmental Response Compensation and Liabilities Act. MS thesis, AFIT/GEE/ENS/95D-01. School of Engineering, Air Force Institute of Technology (AU), Wright-Patterson AFB OH, December 1995 (number not available yet).
- Clemen, Robert T. Making Hard Decisions, An Introduction to Decision Analysis. Belmont, CA: Wadsworth Publishing Company, 1991.
- Covello, Vincent T. and Miley W. Merkhofer. Risk Assessment Methods. New York: Plenum Press, 1993.
- Crouch, E. A. C. "The Risk of Drinking Water," Water Resources Research vol. 19 no. 6. 1359-1375 (December 1983).
- Crouch, E. A. C., R Wilson, and L. Zeise. "Uncertainties in Interspecies Extrapolation of Carcinogenicity," Environmental Health Perspectives vol. 50. 321-327 (1983).
- Crouch, Edmund and Richard Wilson. "Regulations of Carcinogens," Risk Analysis vol. 1 no. 1. 7-57 (1981).
- Cullen, Alison C. "Measures of Compounding Conservatism in Probabilistic Risk Assessment," Risk Analysis vol. 14 no. 4. 389-391 (1994).
- Devore, Jay L. Probability and Statistics for Engineering Sciences (Fourth Edition). New York: Duxbury Press, 1995.
- Dienemann, Erik, and others. "Evolution of Superfund Remedy Selection Process, Including Assessment of Implementation of Permanent and Alternative Remedial Technologies," Environmental Progress Vol 11 No 3: 165-172 (August 1992).
- Duplancic, Neno and Gregory Buckle. "Hazardous Data Explosion," Civil Engineering v59: 68-70 (December 1989).
- Duplancic, Neno and Gregory Buckle. "Hazardous Waste: Quicker Cleanup," Forum for Applied Research and Public Policy. 50-55 (Spring 1993).
- The Earth Technology Corporation. Final Risk Assessment Report For Air Force Plant 44, Tuscon, Arizona. Contract 911020-01. Alexandria, Virginia: August 1993

Elliot, Gordon M. "Risk Assessment and Contaminated Sites," American Society for Testing and Materials, Special Publication No. 1158. 260-276 (1992).

Ember, Lois. "Industry Coalition Slams Superfund," Chemical and Engineering News (GCEN) v17 Issue 31: 19 (August 1993).

Engineering Science. Final Remedial Investigation Report for Operable Unit 2 at Wright-Patterson Air Force Base, Ohio. Contract DE-AC05-0840r21400. Oak Ridge, TN: August 1995.

Finkel, Adam M. and John S. Evans. Evaluating the Benefits of Uncertainty Reduction in Environmental Health Risk Management," Journal of Air Pollution Control Association 37: 1164-1171 (1987).

Finley, Brent and Dennis Paustenbach. "The Benefits of Probabilistic Exposure Assessment: Three Case Studies Involving Contaminated Air, Water, and Soil," Risk Analysis Vol 14 No 1: 53-73 (February 1994).

Finley, Brent, *et al.* "Recommended Distributions for Exposure Factors Frequently Used in Health Risk Assessment," Risk Analysis Vol 14 No 4: 533-553 (1994).

Gaylor, David W., James J. Chen, and Daniel M. Sheehan. "Uncertainty in Cancer Risk Estimates," Risk Analysis Vol. 13 No. 2. 149-154 (1993).

Gilbert, Richard O. Statistical Methods for Environmental Pollution Monitoring. New York: Van Nostrand Reinhold, 1987.

Graham, John and others. "Role of Exposure Databases in Risk Assessment," Archives of Environmental Health Vol 47: 408-420 (1992).

Haimes, Yacov Y. and others. "When and How Can You Specify a Probability Distribution When You Don't Know Much?," Risk Analysis vol. 14 No. 5. 661-703 (1994).

Hattis, Dale, and David Burmaster. "Assessment of Variability and Uncertainty Distributions for Practical Risk Analysis," Risk Analysis Vol. 14 No. 5: 713-730 (1994).

Israeli, Miron, and Christopher B. Nelson. "Distribution and Expected Time of Residence for U.S. Households," Risk Analysis Vol. 12 No. 1: 65-72 (1992).

Katsumata, P.T. and W.E. Kastenberg. "On the Use of Uncertainty Propagation methods for Estimating Health Risks," 5th International Conference on the Developmental Application of Computer Techniques of Environmental Studies. 16-18 Nov. 1994. San Francisco.

- Keenan, Russell E., Brent L. Finley, and Paul S. Price. "Exposure Assessment: Then, Now, and Quantum Leaps in the Future," Risk Analysis Vol. 14 No. 3: 225-230 (1994).
- Kimmel, Carole A. "Quantitative Approaches to Human Risk Assessment for Noncancer Health Effects," Neurotoxicology vol 11. 189-198 (1990).
- Layton, David W. "Metabolically Consistent Breathing Rates for Use in Dose Assessments," Health Physics Vol. 64 No. 1. 23-36 (1993).
- Lawrence, Barnett. "EPA's Superfund Accelerated Cleanup Model: A Paradigm for CERCLA Reauthorization," Environmental Reporter-BNA. 2962-2966 (April 1993).
- Lowrance, S.K. "Corrective Action: Task With a Big Future". Environmental Protection Agency Journal vol. 17 no. 3. 47-48 (1991).
- Masters, Gilbert M. Introduction to Environmental Engineering and Science. Englewood Cliffs: Prentice Hall, 1991.
- MathSoft. User's Guide Mathcad 6.0 Plus. Cambridge, MA: MathSoft, 1995.
- McKone, Thomas E. "Uncertainty and Variability in Human Exposures to Soil Contaminants Through Home Grown Food: A Monte Carlo Assessment," Risk Analysis Vol. 14 No. 4: 449-461 (1994).
- Morgan, M. Granger, and Max Henrion. A Guide to Dealing with Uncertainty in Quantitative Risk and Policy Analysis. New York: Cambridge University Press, 1990.
- National Archives and Records Administration. Code of Federal Regulations: Protection of Environment. CFR Title 40. Rockville, MD: Government Institutes, Inc., 1 July 1993.
- National Research Council. Risk Assessment in the Federal Government: Managing the Process. Washington DC: National Academy Press, 1983.
- . Science and Judgement in Risk Assessment. Washington DC: National Academy Press, 1994.
- Ott, Wayne R., "A Physical Explanation of the Lognormality of Pollutant Concentrations," Journal of Air Waste Management Association Vol 40: 1378-1383 (1990).
- Phillips, Linda J., Robert J. Fares, and Gregory Schweer. "Distributions of Total Skin Surface Area to Body Weight Ratios for Use in Dermal Exposure Assessments," Journal of Exposure Analysis and Environmental Epidemiology Vol. 3 No. 3. 331-338 (1993).
- Roseberry, Ann M., and David E. Burmaster. "Lognormal Distributions for Water Intake by Children and Adults," Risk Analysis Vol. 12 No. 1: 99-104 (1992).

Smith, Andrew E., P. Barry Ryan, and John S. Evans. "The Effect of Neglecting Correlations When Propagating Uncertainty and Estimating the Population Distribution of Risk," Risk Analysis Vol 14 No 4: 433-439 (1994).

Smith, Roy L. "Use of Monte Carlo Simulation for Human Exposure Assessment at a Superfund Site," Risk Analysis Vol 14 No 4: 433-439 (1994).

Thompson, Kimberly M., David E. Burmaster, and Edmund A.C. Crouch. "Monte Carlo Techniques for Quantitative Uncertainty Analysis in Public Health Risk Assessments," Risk Analysis Vol 12 No 1: 53-63 (1992).

United States Environmental Protection Agency. Exposure Factors Handbook. EPA 600/8-89/043, July 1989a.

----- Guidelines for Exposure Assessment. Federal Register, 57 No 104: 22888-22937 (May 29, 1992a).

----- "Memorandum of Guidance on Risk Characterization for Risk Managers and Risk Assessors". Office of the Administrator Washington DC 26 February 1992b.

----- "Reducing Risk: Setting Priorities and Strategies for Environmental Protection," Report No. SAB/EC/90/021. Washington, DC: GPO, 1990.

----- Risk Assessment Guidance for Superfund, Volume 1, Human Health Evaluation Manual (Part A), Interim Final, OSWER 540/1-89 002, December 1989c.

----- Risk Assessment Guidance for Superfund, Volume 1, Human Health Evaluation Manual (Part C, Risk Evaluation of Remedial Alternatives), Interim, OSWER 540/1-89 002, December 1991a.

----- Risk Assessment Guidance for Superfund, Volume 1, Human Health Evaluation Manual Supplemental Guidance: Standard Default Exposure Factors, OSWER Dir. 9285.6-03. Washington DC. GPO, 1989b.

----- "Supplemental Guidance to RAGS: Calculating the Concentration Term," OSWER Intermittent Bulletin vol. 1 no. 9285.7-081, May 1992c.

----- Superfund Chemical Data Matrix. EPA/540/R-94/009. Washington: Office of Solid Waste and Emergency Response, June 1994.

von Stackelberg, Katherine, and David E. Burmaster. "A Discussion on the Use of Probabilistic Risk Assessment in Human Health Impact Assessment," Environmental Impact Assessment Review Vol. 14. 385-401 (1994).

Vita

Alejandro Hinojos was born in Juarez, Mexico on 19 May 1969 to Jesus and Raquel Hinojos. His family immigrated to the United States when he was 5 years old. He lived most of his life in El Paso, Texas, where he graduated from Parkland High School in May of 1988. In June of 1988, he became a naturalized citizen of the United States. On July 10, 1988 Alejandro entered the United States Air Force Academy Preparatory School and graduated the following year. He received his appointment to the United States Air Force Academy and began Basic Training in June of 1989. Four years later he graduated with a Bachelors of Science in Mechanical Engineering as a distinguished military graduate from the Academy. His first assignment was with the 47th Civil Engineering Squadron, Laughlin AFB, as the Environmental Flight Pollution Prevention Element Leader. In May of 1995, he entered the post graduate education program at the Air Force Institute of Technology where he received a Masters of Science in Engineering and Environmental Management. He married Carolyn Anne Drugan in the Fall of 1993 and they have three children.

REPORT DOCUMENTATION PAGE			Form Approved OMB No. 0704-0188	
Public reporting burden for this collection of information is estimated to average 1 hour per response, including the time for reviewing instructions, searching existing data sources, gathering and maintaining the data needed, and completing and reviewing the collection of information. Send comments regarding this burden estimate or any other aspect of this collection of information, including suggestions for reducing this burden, to Washington Headquarters Services, Directorate for Information Operations and Reports, 1215 Jefferson Davis Highway, Suite 1204, Arlington, VA 22202-4302, and to the Office of Management and Budget, Paperwork Reduction Project (0704-0188), Washington, DC 20503.				
1. AGENCY USE ONLY (Leave blank)	2. REPORT DATE December 1996	3. REPORT TYPE AND DATES COVERED Master's Thesis		
4. TITLE AND SUBTITLE Applying Probabilistic Risk Assessment and Decision Analysis Techniques to Avoid Excessive Remedial Investigation Costs			5. FUNDING NUMBERS	
6. AUTHOR(S) ALEJANDRO HINOJOS, 1st Lt, USAF				
7. PERFORMING ORGANIZATION NAME(S) AND ADDRESS(ES) Air Force Institute of Technology (AFIT) Wright Patterson AFB, OH 45433-6583			8. PERFORMING ORGANIZATION REPORT NUMBER AFIT/GEE/ENS/96D-02	
9. SPONSORING / MONITORING AGENCY NAME(S) AND ADDRESS(ES)			10. SPONSORING / MONITORING AGENCY REPORT NUMBER	
11. SUPPLEMENTARY NOTES				
12a. DISTRIBUTION / AVAILABILITY STATEMENT Approved for public release; distribution unlimited			12b. DISTRIBUTION CODE	
13. ABSTRACT (Maximum 200 words) The majority of remediation resources have been consumed by costly and lengthy remedial investigation studies to characterize the human health risk (Lawrence, 1993:2963). Unable to deal directly with the uncertainty resulting from the convolution of the uncertainties in a multitude of variables, and heavily persuaded by the liabilities, decision makers and regulators have relied on conservative assumptions and more studies to take appropriate actions (Graham <i>et al.</i> , 1992:411). The main objective of this research is to provide tools and techniques to aid risk analysts in determining whether it would be beneficial to gather additional information or whether the decision to take an appropriate action can be made without further investigation. This research provides some probabilistic risk assessment and decision analysis techniques to avoid using simple conservative assumptions to deal with the complex uncertainties to evaluate the value of information of additional studies in the complex remediation decision process. The methodologies in this research were tested on Operable Unit 2, Wright-Patterson AFB, Ohio, and Site 4, Air Force Plant 44, Arizona.				
14. SUBJECT TERMS probabilistic risk assessment, decision analysis, value of information, remedial investigation sensitivity analysis, monte carlo, uncertainty analysis, relative influence			15. NUMBER OF PAGES 183	
			16. PRICE CODE	
17. SECURITY CLASSIFICATION OF REPORT Unclassified	18. SECURITY CLASSIFICATION OF THIS PAGE Unclassified	19. SECURITY CLASSIFICATION OF ABSTRACT Unclassified	20. LIMITATION OF ABSTRACT UL	

GENERAL INSTRUCTIONS FOR COMPLETING SF 298

The Report Documentation Page (RDP) is used in announcing and cataloging reports. It is important that this information be consistent with the rest of the report, particularly the cover and title page. Instructions for filling in each block of the form follow. It is important to *stay within the lines* to meet *optical scanning requirements*.

Block 1. Agency Use Only (Leave blank).

Block 2. Report Date. Full publication date including day, month, and year, if available (e.g. 1 Jan 88). Must cite at least the year.

Block 3. Type of Report and Dates Covered. State whether report is interim, final, etc. If applicable, enter inclusive report dates (e.g. 10 Jun 87 - 30 Jun 88).

Block 4. Title and Subtitle. A title is taken from the part of the report that provides the most meaningful and complete information. When a report is prepared in more than one volume, repeat the primary title, add volume number, and include subtitle for the specific volume. On classified documents enter the title classification in parentheses.

Block 5. Funding Numbers. To include contract and grant numbers; may include program element number(s), project number(s), task number(s), and work unit number(s). Use the following labels:

C - Contract	PR - Project
G - Grant	TA - Task
PE - Program Element	WU - Work Unit Accession No.

Block 6. Author(s). Name(s) of person(s) responsible for writing the report, performing the research, or credited with the content of the report. If editor or compiler, this should follow the name(s).

Block 7. Performing Organization Name(s) and Address(es). Self-explanatory.

Block 8. Performing Organization Report Number. Enter the unique alphanumeric report number(s) assigned by the organization performing the report.

Block 9. Sponsoring/Monitoring Agency Name(s) and Address(es). Self-explanatory.

Block 10. Sponsoring/Monitoring Agency Report Number. (If known)

Block 11. Supplementary Notes. Enter information not included elsewhere such as: Prepared in cooperation with...; Trans. of...; To be published in.... When a report is revised, include a statement whether the new report supersedes or supplements the older report.

Block 12a. Distribution/Availability Statement. Denotes public availability or limitations. Cite any availability to the public. Enter additional limitations or special markings in all capitals (e.g. NOFORN, REL, ITAR).

DOD - See DoDD 5230.24, "Distribution Statements on Technical Documents."

DOE - See authorities.

NASA - See Handbook NHB 2200.2.

NTIS - Leave blank.

Block 12b. Distribution Code.

DOD - Leave blank.

DOE - Enter DOE distribution categories from the Standard Distribution for Unclassified Scientific and Technical Reports.

NASA - Leave blank.

NTIS - Leave blank.

Block 13. Abstract. Include a brief (*Maximum 200 words*) factual summary of the most significant information contained in the report.

Block 14. Subject Terms. Keywords or phrases identifying major subjects in the report.

Block 15. Number of Pages. Enter the total number of pages.

Block 16. Price Code. Enter appropriate price code (*NTIS only*).

Blocks 17. - 19. Security Classifications. Self-explanatory. Enter U.S. Security Classification in accordance with U.S. Security Regulations (i.e., UNCLASSIFIED). If form contains classified information, stamp classification on the top and bottom of the page.

Block 20. Limitation of Abstract. This block must be completed to assign a limitation to the abstract. Enter either UL (unlimited) or SAR (same as report). An entry in this block is necessary if the abstract is to be limited. If blank, the abstract is assumed to be unlimited.