

# NATIONAL AIR INTELLIGENCE CENTER



THE PRESENT STATUS AND DEVELOPMENT TRENDS OF THE FM/CW RADAR DETONATOR  
FOR THE ANTI-AIR MISSILE

by

Ya-Jun Zhang

*DTIC QUALITY INSPECTED 2*



**Approved for public release:  
distribution unlimited**

19970206 039

**HUMAN TRANSLATION**

NAIC-ID(RS)T-0385-96

5 November 1996

MICROFICHE NR:

THE PRESENT STATUS AND DEVELOPMENT TRENDS OF THE FM/CW/RADAR DETONATOR FOR THE ANTI-AIR MISSILE

By: Ya-Jun Zhang

English pages: 23

Source: Aero Weaponary, Nr 5, 1995, (Cama, Vol. 3, Nr. 1, 1996); pp. 1-10

Country of origin: China

Translated by: SCITRAN

F33657-84-D-0165

Requester: NAIC/TASC/Richard A. Peden, Jr.

Approved for public release: distribution unlimited.

<p>THIS TRANSLATION IS A RENDITION OF THE ORIGINAL FOREIGN TEXT WITHOUT ANY ANALYTICAL OR EDITORIAL COMMENT STATEMENTS OR THEORIES ADVOCATED OR IMPLIED ARE THOSE OF THE SOURCE AND DO NOT NECESSARILY REFLECT THE POSITION OR OPINION OF THE NATIONAL AIR INTELLIGENCE CENTER.</p>	<p>PREPARED BY: TRANSLATION SERVICES NATIONAL AIR INTELLIGENCE CENTER WPAFB, OHIO</p>
---	---

**GRAPHICS DISCLAIMER**

All figures, graphics, tables, equations, etc. merged into this translation were extracted from the best quality copy available.

The Present Status and Development Trends of The FM/CW Radar Detonator  
for The Anti-air Missile

Ya-Jun Zhang

(The No. 014 research center of Aviation Industry Corporation, Henan,  
Luoyang, 471009)

**Abstract:** On the basis of the brief introduction to the FM/CW radar detonator's basic theory and some kinds of advanced FM/CW radar detonators in the foreign countries, combining the development of the modern radar technology, we make a summary of some development characteristics and trends of the modern FM/CW radar detonator, and raise a new intellectualized FM/CW radar detonator scheme with multiple functions and strong anti-interference ability.

**Key Words:** FM/CW detonator, Intellectualization, Detonator ECCM technology

1. Introduction

The detonator of the Anti-air Missile always employs infrared, laser and radar near explosion detonator technologies. The working theory of the radar near explosion detonator is the same as that of the radar, they all can be used to measure the distance, speed and the position of the target. But the radar near explosion detonator has its own working characteristic, that is the short range measurement and the one time usage. The target of the anti-air missile is usually dealt with as the point target, but the size and the measurement distance of the target which the radar detonator of the anti-air missile will measure (such as the plane or the missile) can be compared, so the target need to be dealt with as a body target.

The sender and the receiver of the active radar detonator are in the same aircraft, in this circumstance, the delay time  $\tau$  of the reflecting signal compared with the emitted signal is:

$$\tau = \frac{2R}{c} \quad (1)$$

where  $R$  is the distance between the missile and the target,  
 $c$  is the propagation speed of the electromagnetic wave.

The relative motion between the missile and the target, cause the Doppler effect, the Doppler frequency can be expressed as:

$$f_d = \frac{2V_r}{\lambda_0} \cos \alpha \quad (2)$$

where  $V_r$  is the relative speed between the missile and the target,  
 $\alpha$  is the included angle between the relative speed vector and the linking line of the missile and the target,  
 $\lambda_0$  is the carrier wave wavelength of the radar detonator.

From the equation (1) and (2) we can see that, the speed and distance measuring theory of the radar detonator is the same as the radar theory, they all measure the echo wave signal's delay time related to the emitted signal and the Doppler shift caused by the relative motion.

The anti-air missile's radar detonators that are currently designed and applied can be mainly divided into two types according to the different forms of the emitted signal, they are the frequency modulation system

P2

and the amplitude modulation system. The former one is the frequency modulation continuous wave (FM/CW) radar near explosion detonator, the latter is the pulse radar near explosion detonator. Different working scheme can be made up according to the different combinations of the modulation forms. The frequency modulation system includes single

frequency modulation (such as the sinusoidal wave, triangle wave, and sawtooth wave, etc.) FM/CW, multiple sinusoidal wave combination FM/CW, special wave FM/CW, noise and sinusoidal wave combination FM/CW, pseudo random code or random code phase modulation and sinusoidal wave combination FM/CW near explosion detonator, etc. The amplitude modulation system includes pulse Doppler, random pulse position modulation Doppler, pulse Doppler and pseudo code or random code phase modulation combination modulation near explosion detonator, and so on. The frequency modulation system and the pulse system also can be applied together, such as the linear frequency modulation and pulse Doppler combination scheme near explosion detonator, etc.

FM/CW radar detonator has some good characteristics. It is compatible with the solid sender, it has the best anti electronic interference characteristic, it can extract many information (such as the distance, relative speed, target and the background characteristic) from the frequency difference easily. In is suitable for the intellectualized processing. So it is widely applied in the anti-air missile's near explosion detonator.

With the rapid development of the microwave integration, monolithic microwave integrated circuit, large scale digital integrated circuit and the modern signal processing techniques, it is possible to design and develop the intellectualized FM/CW radar detonator with multiple functions and strong anti-interference ability.

## 2. The basic information characteristic of the FM/CW radar detonator

In the continuous wave frequency modulation ( FM/CW ) radar detonator, we usually employ the direct coherent frequency mixing of the echo signal and the emitted signal, use the zero intermediate frequency receiver to extract the information of the distance between the missile and the target, and speed. etc. The most basic block diagram of the FM/CW detonator's front part is shown in the figure 1.



图1 FM/CW 雷达引信前端框图

(1) transmitting antenna (2) transmitter (3) modulator (4) receiving antenna

(5) frequency mixer (6) intermediate frequency output

Figure 1. The front part block diagram of the FM/CW radar detonator

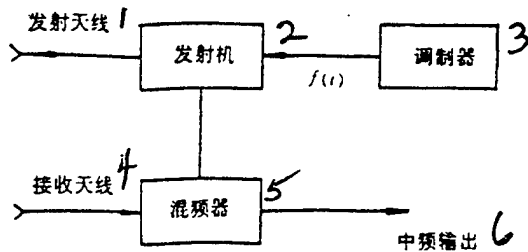
In theory, the modulation signal  $f(t)$  of the transmitting frequency can be any waveform. But usually the waveform that can be easily produced will be employed, such as the sinusoidal wave, the symmetric triangle wave, the sawtooth wave and so on. In the modern FM/CW radar detonator, in order to improve the system performance, to enhance the anti-interference ability of the system, the complicated frequency modulation law is employed, such as multiple sinusoidal wave combination modulation, random coding modulation, noise modulation, sinusoidal wave plus noise combination and some other special waveform modulation techniques.

When the modulation signal  $f(t)$  is the single sinusoidal signal, the intermediate frequency output of the frequency mixer is:

$$\begin{aligned}
 u_1(t) = E_1 \{ & J_0(u) \cos(\omega_0 \tau - \Omega_d t) - J_1(u) (\sin[(\Omega_m - \Omega_d)t + \omega_0 \tau_0] \\
 & - \sin[(\Omega_m + \Omega_d)t - \omega_0 \tau_0]) - J_2(u) (\cos[(2\Omega_m - \Omega_d)t + \omega_0 \tau_0] \\
 & + \cos[(2\Omega_m + \Omega_d)t - \omega_0 \tau_0]) + \dots \} \\
 (3) \quad u = & \frac{\Delta \omega}{\Omega_m} \sin \frac{\Omega_m \tau}{2}
 \end{aligned}$$

From the equation (3) we can see that the intermediate frequency output signal includes the Doppler frequency component whose amplitude is  $J_0(u)$ , and the infinite components whose frequency is the multiplier as the modulation frequency  $\Omega_m$ . These components have the amplitudes that

is respectively in the direct proportion to  $J_n(u)$  and are modulated by the Doppler component (the carrier frequency  $n\Omega_c$  is suppressed). Each component carries the distance information through  $J_n(u)$ , carries speed information through  $\Omega_c$ .

The spectrum of the intermediate frequency signal is shown in figure 2 (the amplitude is excluded).

When the modulation signal  $f(t)$  is a single symmetric triangle wave, the output signal of the frequency mixer is:

$$(4) \quad u_f(t) = E_f \operatorname{Re} [e^{j(\omega_c t + \theta)} \sum_{n=-\infty}^{\infty} A_n e^{jn\omega_c t}]$$

where the amplitude function #9

$$(5) \quad \text{其中: 幅度函数 } A_n = \frac{2u \sin[(u-n)\frac{\pi}{2}]}{\pi(u^2 - n^2)}$$

P3

The modulation index is  $u = 2\Delta f\tau$

When the modulation signal  $f(t)$  is a sawtooth wave, the output signal of the frequency mixer can be expressed as:

$$(6) \quad u_f(t) = E_f \operatorname{Re} [e^{j(\omega_c t + \theta)} \sum_{n=-\infty}^{\infty} A_n e^{jn\omega_c t}]$$

$$(7) \quad A_n = \frac{(-1)^n u \sin n\pi}{\pi(u^2 - n^2)}$$

$u = \Delta f\tau$

When the modulation signal is the triangle wave or the sawtooth wave, the spectrum of the intermediate frequency output is the same as in the figure 2.



图2 正弦波调制时中频信号  
频谱(不表示幅度)

Figure 2. The spectrum of the intermediate frequency signal when modulated by the sinusoidal wave (the amplitude is not included)

In order to improve the distance cutoff characteristic of the FM/CW detonator, usually the multiple sinusoidal waves are combined (such as double sinusoidal wave, triple sinusoidal wave, etc.), or different modulation schemes are combined together.

The above equations are under the assumption that the target is a point target. In the FM/CW near explosion detonator, the echo wave signal comes from the body target's surface (such as the plane) where the antenna wave beam irradiates. Usually the target includes many independent scatters, the distances between the scatter center in each scatter and the detonator antenna are different. Thus, the total echo wave signal is the vector synthetics of the multiple echo wave signals with different delay time and different amplitude. For the body target, the spectrum of the echo wave signal will be widened.

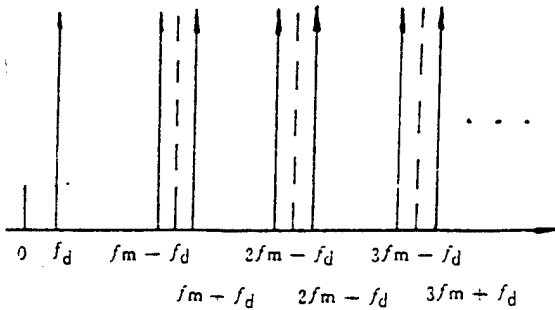
In the FM/CW detonator system, each harmonic wave of the echo wave signal carries the distance and speed information. When we processing the signal, a single echo wave signal's spectral line could be used to extract the distance and speed data. If the narrow band receiver is used, the usage of the frequency gating can increase the signal to noise ratio. Due

to the rapid development of the modern signal processing techniques, we can do multiple spectrums processing for each main harmonic wave component of the echo wave signal, thus to increase the signal's utilization coefficient.

The FM/CW radar distance measuring and speed measuring technologies is widely applied in the modern anti-air missile's near explosion detonator, the following are some application examples of the missile's detonator.

### 3. A brief introduction of several FM/CW radar detonator

#### 3.1 The special wave FM/CW detonator

This kind of detonator employs the special continuous wave frequency modulation correlation scheme with large product of time and band width. The modulation wave is:

$$f(t) = K \cdot e^{-\left(\frac{t-T}{T}\right)^2} \quad (8)$$

where  $K$  is the amplitude constant,  $\Delta f$  is the modulation band width,  $T$  is the modulation period.

This kind of detonator is adopted by some antiaircraft missile. The block diagram is shown in figure 3.

The distance cutoff characteristic of the detonator is shown in figure 4.

The main functions and the characteristics of the this detonator include:

a. The detonator adopts the special wave frequency modulation, and employs the correlation and the spectrum weighting techniques in the receiver, thus obtains good sharp distance cutoff characteristic, has the ultra-low altitude working ability (15 ~ 20m).

b. The adoption of the constant false warning circuit processing, warning branch channel and the variable sensitivity adjustment techniques can keep the constant false warning probability and thus achieve strong anti-interference ability.

c. The adoption of the Doppler signal branch processing using low, intermediate and high filter decreases the pass band of the receiver, increases the detonator output

P4

S/N, also can do the adaptive delay adjustment according to the different intersection speed.



图3 某防空导弹引信原理框图

Figure 3. The theory block diagram of an anti-aircraft missile's detonator

- (1) power distributor
- (2) frequency multiplication
- (3) frequency mixer
- (4) modulator
- (5) amplifier
- (6) correlation and spectrum weighting
- (7) multiple channels amplifier
- (8) Doppler branch processing

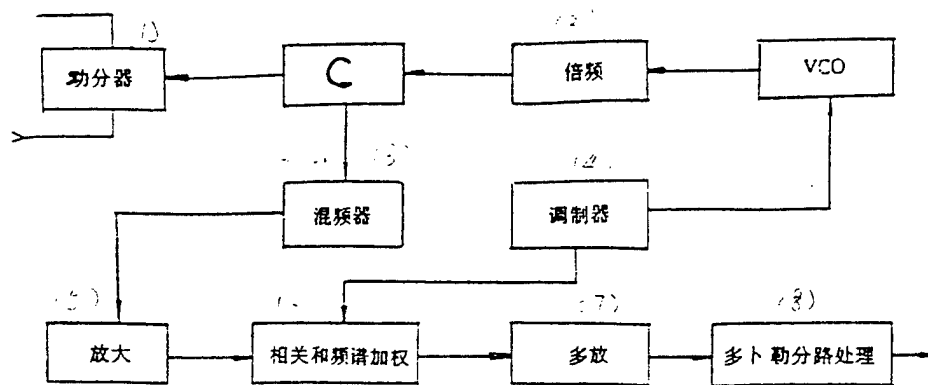

图4 引信的距离截止特性

figure 4. The distance cutoff characteristic of the detonator  
(1) sensitivity

### 3.2 The multiple sinusoidal wave combination FM/CW detonator

This kind of detonator employ the combination of multiple sinusoidal waves with the carrier wave modulation:

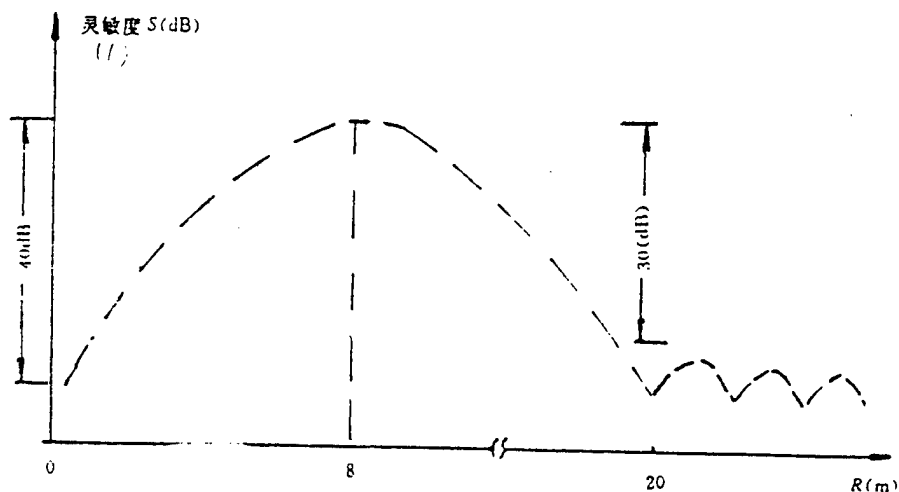
$$(9) \quad f(t) = A_1 \cos \omega_{m1} t + A_2 \cos \omega_{m2} t + A_3 \cos \omega_{m3} t + \dots$$

The block diagram of the detonator is shown in figure 5.

The main functions and the characteristics of this kind of detonator include:

- a. The detonator has the sharp cutoff characteristic, strong anti-interference and low altitude working ability, all these are due to the adoption of the multiple sinusoidal wave combination frequency modulation and the usage of the correlation and the side band receiving technologies.
- b. The detonator can identify if the target is leaving or approaching after the adoption of the special signal processing technique. Using the Doppler passing zero test, it achieves good guiding and warhead cooperation performance.

### 3.3 The single signal FM/CW detonator

This kind of detonator employs the single signal to modulate the carrier wave, its block diagram is shown in figure 6.



图5 多正弦复合 FM/CW 引信框图

Figure 5. The block diagram of the multiple sinusoidal wave combination FM/CW detonator

(1) power distributor (2) FM oscillator (3) sinusoidal wave combination modulator (4) phase shifting (5) frequency mixer (6) intermediate frequency amplifier (7) second frequency mixer (8) signal processing (9) frequency mixer (10) intermediate frequency amplifier (11) second frequency mixer

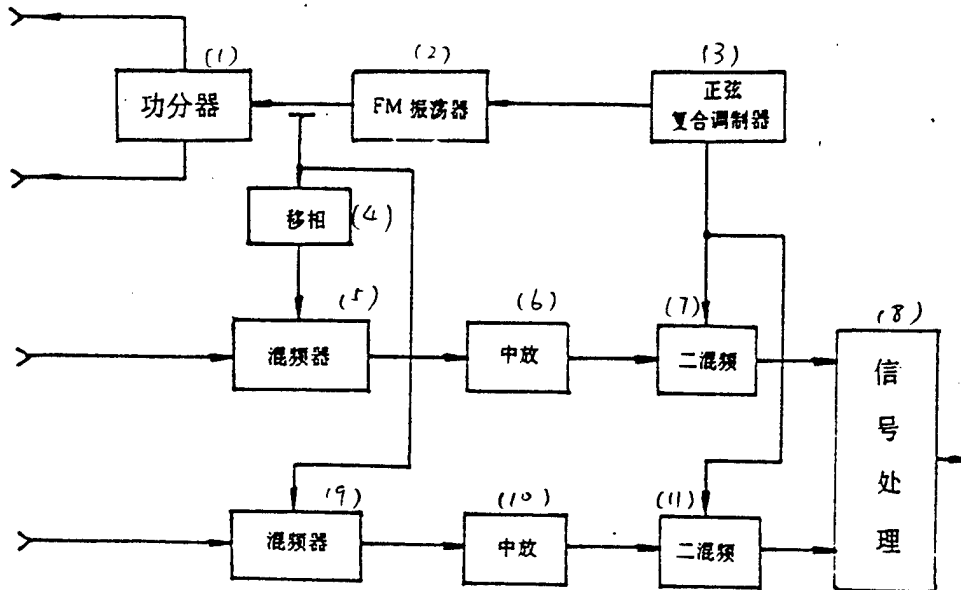
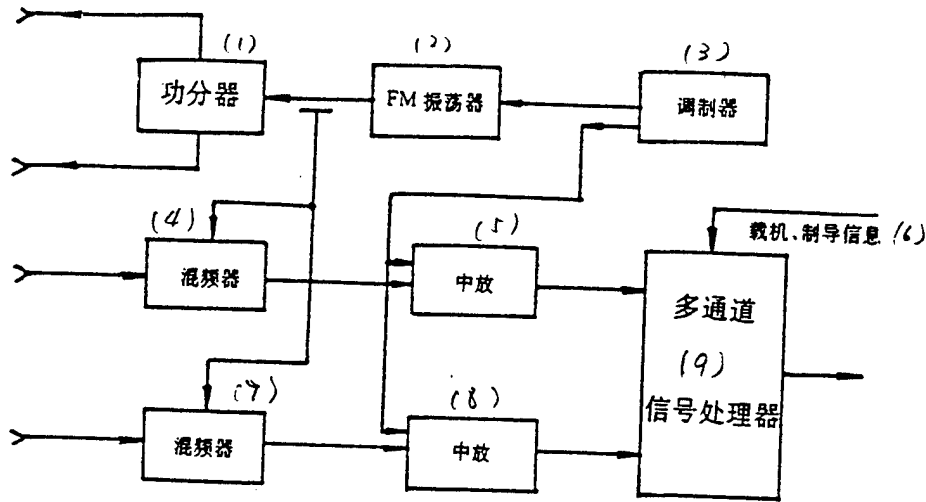

Figure 6. The block diagram of the single signal FM/CW detonator  
 (1) power distributor (2) FM oscillator (3) modulator (4) frequency mixer (5) intermediate frequency mixer (6) loading aircraft and guidance information (7) frequency mixer (8) intermediate frequency mixer (9) multiple channels signal processor

The main functions and characteristics of this kind of detonator include:

- a. The detonator has good distance cutoff characteristic and strong anti-interference ability due to the adoption of the continuous wave frequency modulation scheme and the multiple spectrum and anti-interference processing to the received signal.
- b. Using the airborne radar and guidance information to control the adaptive delay ignition, the hit probability increases.

### 3.4 The noise and linear frequency modulation combination FM/CW detonator

This kind of detonator is applied in the air-to-air missile, it has good distance cutoff (0 ~ 14m) characteristic and strong anti-interference ability.

It adjusts the detonator's cutoff distance by changing the frequency

offset of the noise's spectrum. The detonator can work in very low altitude, can attack the target that is just 5 m higher than the sea level. It can reliably process the target signal even the S/N equals to 1.

P6

### 3.5 The sinusoidal wave and noise combination FM/CW detonator

The block diagram of the sinusoidal wave and noise combination FM/CW detonator is shown in figure 7.



图7 正弦加噪声复合FM/CW引信框图

Figure 7. The block diagram of the sinusoidal wave and noise combination FM/CW detonator

(1) oscillator (2) sinusoidal wave (3) band pass filter (4) noise (5) frequency mixer (6) Doppler filter (7) filter 1 (8) detection 1 (9) filter 2 (10) detection 2

The detonator of this kind of scheme has the ability of short range

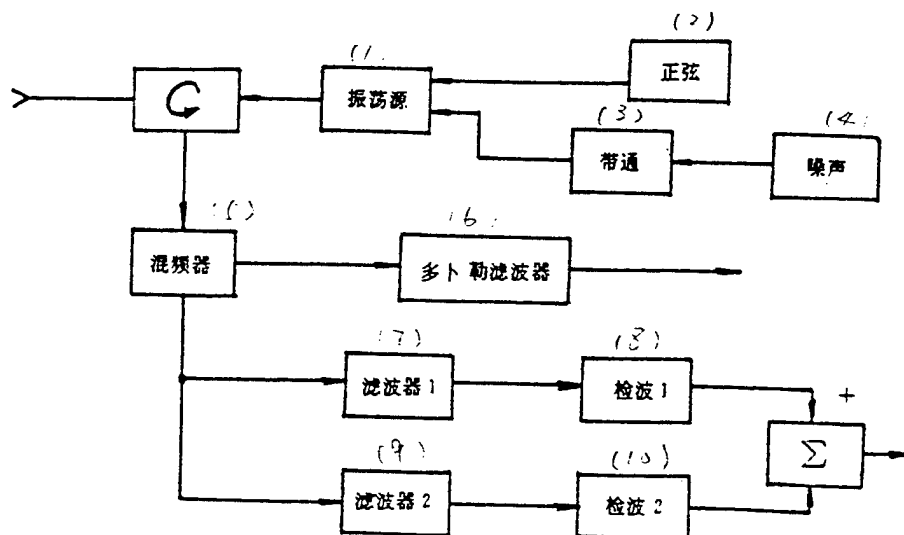
ranging and speed measuring, also has good distance cutoff characteristic and strong anti-interference ability to many kinds of passive and active interference.

### 3.6 The sinusoidal wave frequency modulation and random code phase modulation combination FM/CW detonator

The block diagram of a kind of the sinusoidal wave frequency modulation and random code phase modulation combination FM/CW detonator is shown in figure 8.

This kind of detonator adopts the combined modulation, multiple distance gating correlation detection and synchronized detection technique to achieve the high precision measurement of the distance and the speed, it has strong anti-interference ability.

## 4. The development trends of the FM/CW radar detonator

From the structure and the technical characteristic of the above-mentioned FM/CW detonator, combining the development of the modern radar technique and other related technologies, we can predict the main development trends of the new generation FM/CW radar detonator, shown in the following.

### 4.1 The working frequency band will expand to higher frequency band (mm band)

The modern anti-air FM/CW detonator are almost working in the S, C, X frequency band, in future, it will expand to the mm band. The higher the working frequency, the smaller the size, there is more space for maneuver when designing the antenna, so it will satisfy the need of the modern missile better. The working frequency band is far from the frequency band of the most of the current interference equipment, so the detonator is more difficult to be interfered. The mmW detonator also can obtain large Doppler speed sensitivity and wide working band width.

It is reported by some related materials that, some companies of the

US have developed many kinds of mmW FM/CW radar of high linearity (0.0003% ~ 2%), wide working frequency band width ( 50MHz ~ 1000Mhz ), the working frequency of these radar is 35GHz ~ 140Ghz. The Psion EMI Electron Corporation of British is developing the mmW radar detonator series for extensive application.

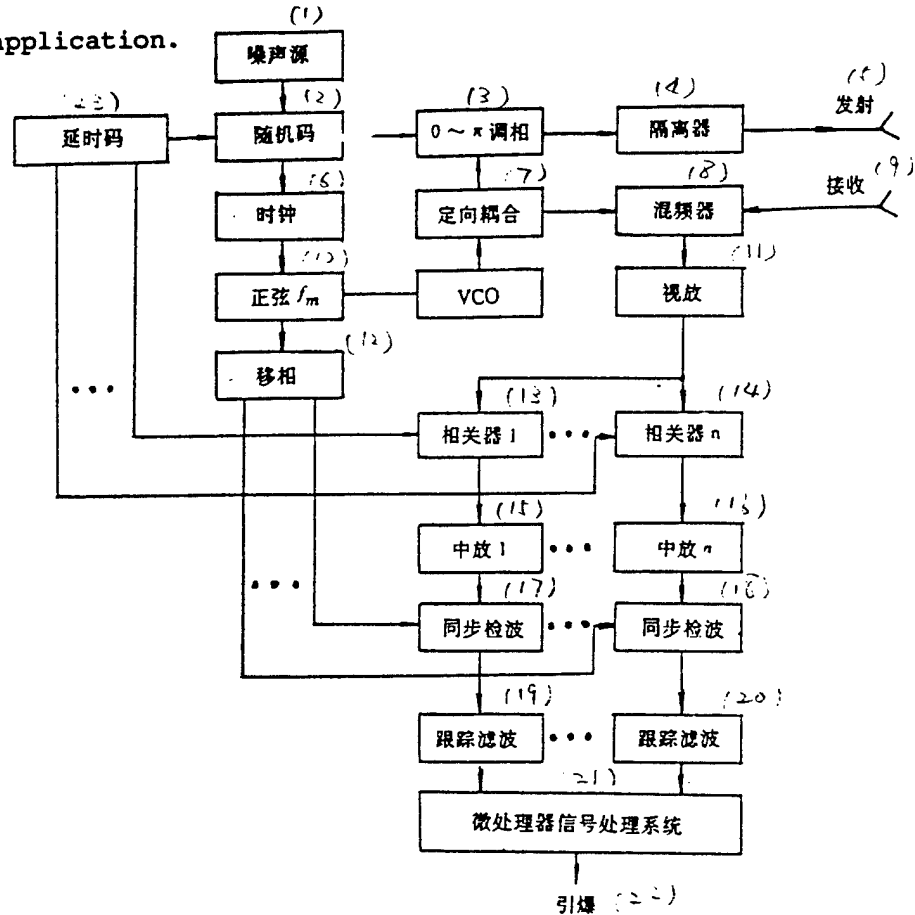

P7

图8 正弦波与随机码复合FM/CW引信框图

Figure 8. The block diagram of the sinusoidal wave frequency modulation and random code phase modulation combination FM/CW detonator

- (1) noise source (2) random code (3)  $0 \sim \pi$  phase modulation (4) segregating unit (5) transmitting (6) clock (7) directional coupling (8) frequency mixer (9) receiving (10) sinusoidal wave fm (11) video frequency amplification (12) phase shifting (13) correlator 1 (14) correlator n (15) intermediate frequency amplifier 1 (16) intermediate frequency amplifier n (17) synchronous detection (18) synchronous detection (19) tracking filter (20) tracking filter (21) microprocessor

signal processing system

(22) detonating (23) delay code

4.2 The conformal technique of the radio frequency antenna and the missile, the microwave integration of the radio frequency front part

The currently used FM/CW radar detonator antennas are mostly waveguide crack antennas. In order to obtain high gain and narrow wave beam, and to reduce the air resistance, it is necessary that the antenna and the missile is conformal, such as the waveguide crack antenna, and conformal microstrip antenna, etc. To satisfy the requirement of many kinds of detonator systems, such as direction selecting detection, it is necessary to design the conformal antenna that has good electrical performance, good performance of the structure and size, high gain, narrow wave beam (meridian plane) and multiple quadrants (equatorial plane).

The radio frequency front part includes the high frequency unit of the receiver and the transmitter. In the future, the radio frequency front part of the FM/CW radar detonator will develop towards the direction of the microwave integration and entirely solid state. Currently the transmitter is using the microwave mixed integrated circuit that consists of the crystal triode and the semi lumped parameter circuit, in the future, it will develop towards the direction of the gallium arsenic field effect transistor and the monolithic microwave integrated circuit. Adopting the double balanced frequency mixer we can design the microwave mixed integrated receiver that has high frequency conversion efficiency, good noise coefficient, good suppression ability to the signal leaking and the parasitic amplitude modulation interference.

In the mmW band, from the middle of the 80's, the western advanced countries have spent a great amount of man power and money to develop the monolithic microwave integrated circuit. They have developed the monolithic millimeter wave integrated circuit that is used in the dexterous weapons (such as the detonator and the terminal guidance missile), and the radio frequency front part that consists of the multiple

function chip. The millimeter wave remote sensor, one of the dexterous weapons that are developed by the west, has the autonomous and all weather fighting ability, the best system cost to efficiency ratio.

The block diagram of a kind of millimeter wave radio frequency front part that is suitable for mostly dexterous weapons is shown in figure 9.



图9 多功能毫米波射频前端

Figure 9. A multiple function millimeter wave radio frequency front part (1) the tuning voltage comes from PLL (2) to PLL (3) PLL down frequency conversion (4) reference oscillator (5) local oscillation distributor (6) up frequency conversion (7) amplifier (8) power amplifier (9) offset frequency (10) low noise amplifier (11) timing (12) switch (13) down frequency conversion (14) transceiver switch (15) single pulse comparater antenna (16) down frequency conversion (17) down frequency conversion (18) low noise amplifier (19) transceiver switch (20) IF output

This kind of radio frequency front part has many function combination, it can work using active, passive and semi-active mode. The whole system can work in the status of continuous wave (CW), frequency modulation continuous wave (FM/CW), frequency modulation intermittent continuous wave (FM/ICW), or pulse wave. It also has many signal functions such as pulse compression wave correlation, prompt frequency changing, etc. To construct the FM/CW radar detonator, only the voltage controlled oscillator (VCO), transceiver switcher and the down frequency conversion in the receiver are needed.

The Defense Department of the US plans to develop several hundred thousands of the millimeter wave remote sensor in the 90's for the dexterous weapon system.

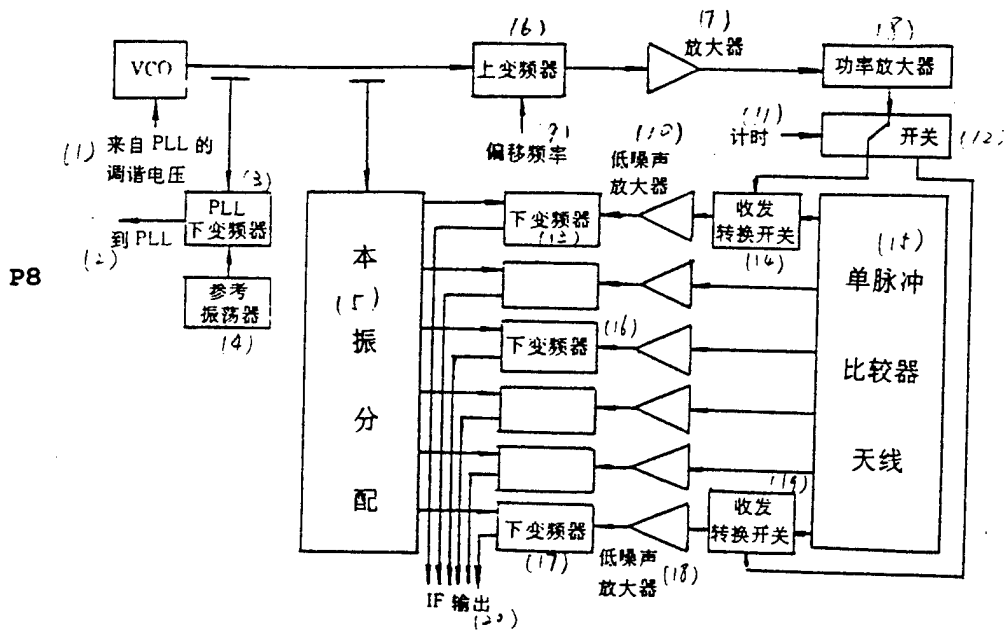
The detonator system in the future will develop towards high integration and modularization. The system designer will consider at the very beginning that the system he designs will consist of how many special integrated circuit modules. It is very advantageous for enhancing the reliability, security and reducing the volume and weight.

4.3 Adopting the waveform design technology of the multiple modulation and the modern signal processing technologies to compose the intelligent detonator system

The FM/CW detonator in the future will pay more attention to the waveform design technology, it will adopt all kinds of modulation techniques to get the thumb tacks fuzzy function, and make the detonator with the sharp distance cutoff characteristic, thus enhance the ultra low altitude performance and anti-interference ability, increase the detonator's ranging and speed measuring precision.

With the rapid development of the large scale digital integrated circuit, especially the appearance of the high speed signal processor, the FM/CW intelligent detonator that adopts all digital modulation and digital processing becomes possible. Using the digital waveform generation

technology, all kinds of waveform can be generated, moreover, the modulation period and the waveform can be program controlled, it makes the detonator suitable for many kinds of combat environment. The high speed signal processing technique makes it possible to fully utilize the abundant target signal of the FM/CW system. The utilization of the fast Fourier transform (FFT) can realize the spectrum analysis, spectrum weighting and spectrum leading edge detection (SLED) and other processing of the echo wave signal, thus achieve more precise information of the target distance, speed and position, and distinguish the real target from the background, enhance the detonator's ability of differentiation and identification and the anti-interference ability. Moreover, the adoption of the intelligent signal processing technique makes it easier to accomplish the integrate design of the detonator and the guidance.

The block diagram of a kind of intelligent FM/CW radar detonator that adopts the microwave radio frequency front part mixed integration or the monolithic microwave integrated circuit, the digital signal synthesis modulation technique, the digital signal

P9

processing technique, and has multiple functions, high reliability, high precision, is shown in figure 10.



图 10 智能数字化 FM/CW 引信组成框图

Figure 10. The block diagram of the intelligent digitized FM/CW detonator  
 (1) transmitting (2) frequency modulation transmitter (3) digital  
 modulator (4) receiving (5) frequency mixer (6) amplifier and filter  
 (7) A/D sampler (8) microprocessor control and digital signal processor  
 (9) guidance signal (10) detonating signal

#### 4.4 Adopting all kinds of electronic counter-measure (ECCM) technique to further the anti-interference ability

The advancement of the future weapon system is not only shown by its own characteristic and performance, the more important factor is the reliable working ability in all kinds of active, passive and background noise interference circumstances. To increase the efficiency of the near explosion detonator by all means first we have to enhance the anti-interference ability.

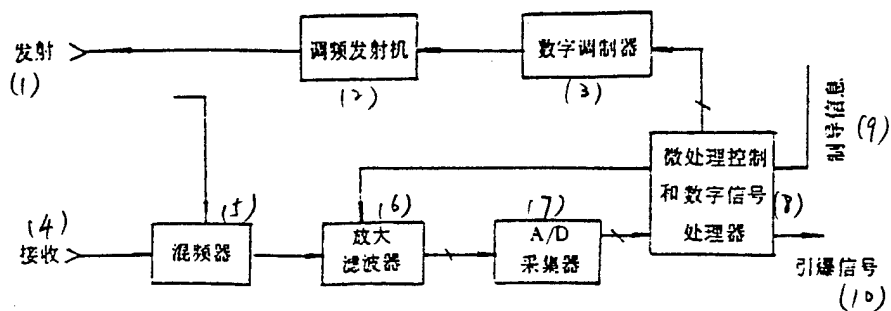
The new generation FM/CW radar detonator also need to have advanced

ECCM techniques. There are many ways to improve the FM/CW detonator's electronic anti-interference performance, such as the waveform design technique, the antenna side lobe blanking technique, all kinds of signal processing techniques, and frequency hopping technique, etc. Also the different combinations of the millimeter wave, microwave and infra-red system could be used to counter interference. These combinations include the binary mode (passive and active) and binary wave band (such as millimeter wave/infrared, C band/Ka band, X band/Ka band, Ku band/95GHz). It is reported that the third generation improvement model of the US's Patriot missile ---- PAC-3 missile employs multiple modes guidance head, on the basis of the already existing semi-active C band guidance, it adds the active Ka band guidance system. In the last several milli second of the missile's flight, the Ka band guidance head transfers to the near explosion detonator working mode. The Patriot missile employs the C band and Ka band binary band combination technique, it enables the missile to effectively deal with all kinds of the deceiving electronic counter measures that are utilized by the currently existing airplanes and cruise missiles.

Now we introduce a kind of FM/CW detonator design scheme that has multiple functions and adopts many ECCM techniques. The block diagram of the theory is shown in figure 11.

On the meridian plane, the C/X band antenna's pattern is designed to be the wide wave beam, the Ka band antenna's pattern is designed to be the narrow wave beam with fore inclination angle. On the equatorial plane, the patterns of the Ka band and the C/X band are the same, it means that a pair of antennas of a wave band form a 360 degree circular pattern (each antenna forms 180 degree).

The ECCM techniques of this scheme include:

The adoption of the binary band (C/Ka band or X/Ka band), multiple waveform combination modulation sharp distance cutoff, double channels antenna blanking technique, varying modulation period technique, advanced

signal processing technology and trajectory closure technology, etc.

The mmW detonator can also be designed to work in the passive working mode. The adoption of the binary mode and the binary band simultaneously has better ECCM performance.

From the block diagram we can see, the counter answering mode interference depends on the binary band, varying modulation and trajectory closure techniques, etc. other counter interference methods depend on the distance selection, speed selection, signal accumulation judgment and the signal processing techniques such as the quadrant spectrum analysis, etc.

Because of the adoption of the multiple channels, multiple quadrants receiving technique, it is relatively convenient to identify the target position during signal processing, thus this detonator cooperates with the directional selection warhead part and forms directional ignition system, increases the hit probability. Another design scheme to obtain the azimuth information is to design multiple quadrants antenna, use single channel in the receiver to do azimuth scanning through the electronic switch. The adoption of the combination detonator technique



图 11 一种具有方位识别和采用多项 ECCM 技术的 FM/CW 引信系统

Figure 11. A kind of FM/CW detonator design scheme that has azimuth identification and adopts multiple ECCM technologies.

- (1) Ka band (2) transmitting (3) FM transmitter (4) combination modulator (5) guidance information (6) Ka antenna assembly (7) frequency mixer (8) intermediate frequency amplifier (9) intermediate frequency mixer (10) receiving (11) frequency mixer (12) intermediate frequency amplifier (13) intermediate frequency mixer (14) multiple channels assembly (15) A/D assembly (16) intelligence control processor (17) detonation (18) transmitting (19) FM transmitting (20) C/X antenna assembly (21) frequency mixer (22) intermediate frequency amplifier (23) intermediate frequency mixer (24) receiving (25) frequency mixer (26) intermediate frequency amplifier (27) intermediate frequency mixer (28) C/X band (29) signal processing

seems more complicated than other single scheme detonator, but if we employ integrated and module design, especially if we reform on the basis of the existing mature technologies, we can achieve fairly good cost to efficiency ratio.

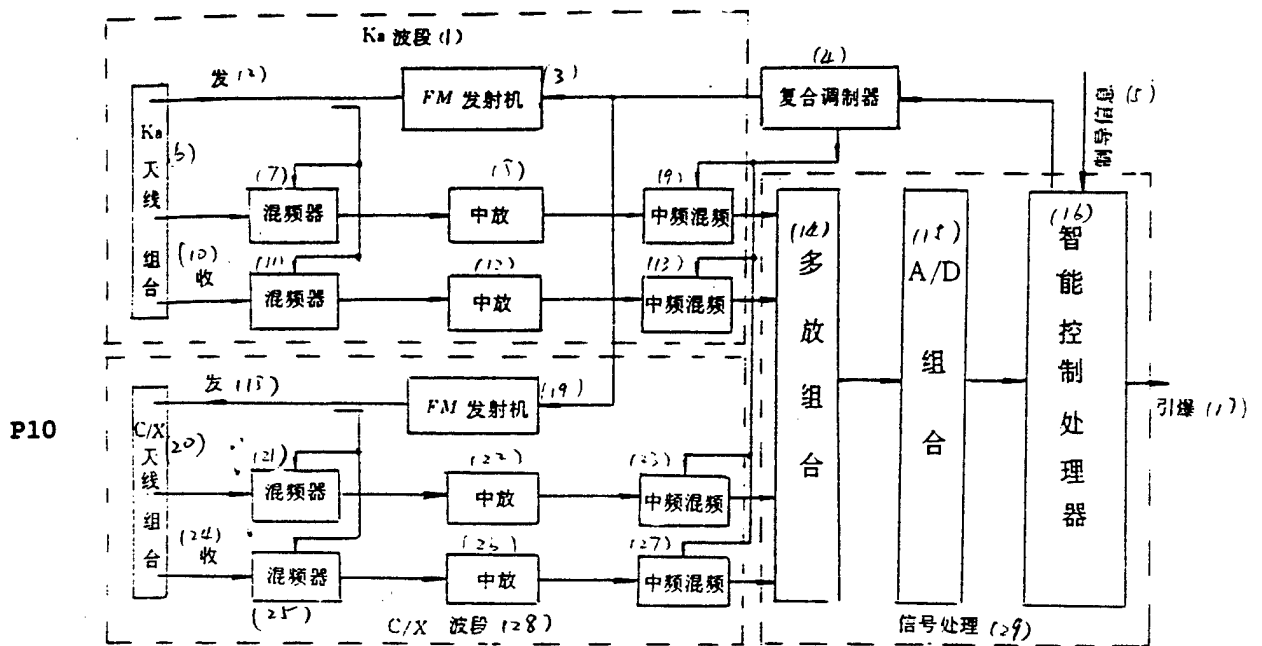
The development trends of the modern FM/CW radar detonator and all kinds of ECCM technologies introduced in this paper also can be applied to all kinds of pulse detonator systems.