

# NATIONAL AIR INTELLIGENCE CENTER



ADAPTIVE PRINCIPLE IN OPTICAL INSTRUMENT DESIGN\*

by

Yin Chunyong, Guo Jihua, Mao Wenwei

DTIC QUALITY INSPECTED 2

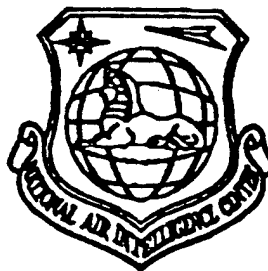

19970206 086

Approved for public release:  
distribution unlimited



**HUMAN TRANSLATION**

NAIC-ID(RS)T-0527-96                      6 January 1997

MICROFICHE NR:

ADAPTIVE PRINCIPLE IN OPTICAL INSTRUMENT DESIGN\*

By: Yin Chunyong, Guo Jihua, Mao Wenwei

English pages: 13

Source: Chinese Journal of Scientific Instrument; pp. 62-66, 71.

Country of origin: China

Translated by: Leo Kanner Associates  
F33657-88-D-2188

Requester: NAIC/TATD/Bruce Armstrong

Approved for public release: distribution unlimited.

THIS TRANSLATION IS A RENDITION OF THE ORIGINAL FOREIGN TEXT WITHOUT ANY ANALYTICAL OR EDITORIAL COMMENT STATEMENTS OR THEORIES ADVOCATED OR IMPLIED ARE THOSE OF THE SOURCE AND DO NOT NECESSARILY REFLECT THE POSITION OR OPINION OF THE NATIONAL AIR INTELLIGENCE CENTER.

PREPARED BY:

TRANSLATION SERVICES  
NATIONAL AIR INTELLIGENCE CENTER  
WPAFB, OHIO

TABLE OF CONTENTS

Graphics Disclaimer .....	ii
0 Introduction .....	2
1. Principles of Adaptive Optics .....	4
2. Research on Wavefront Oblique Correlation of Adjacent Beams .....	6
3. Examples Complying with Adaptive Optics Principle .....	10
4. Conclusions .....	12
REFERENCES .....	12

GRAPHICS DISCLAIMER

All figures, graphics, tables, equations, etc. merged into this translation were extracted from the best quality copy available.

## ADAPTIVE PRINCIPLE IN OPTICAL INSTRUMENT DESIGN\*

Yin Chunyong, Guo Jihua, and Mao Wenwei

Qinghua University

ABSTRACT: The "common path" concept has been used in optical instrument design for 30 years. In fact, the designer tacitly accepts that the light traverses its "path" during a time period that is sufficiently short such that the atmospheric state remains the same. Now, while the measurement range is being extended or the perturbation is intensifying, the atmospheric state no longer remains the same in the given time interval, and thus, the "common path" concept reveals its shortcomings.

Recent studies in nonlinear dynamics have given accurate predictions of the short-term future behavior of atmospherically distorted wave fronts, but the long-term behavior of a chaotic system can never be predicted.

In this paper, the adaptive principle in optical instrument design is recommended. This principle suggests that the designer not only arrange the system to achieve measurement signal but

---

\*This research project was financed by the National Natural Sciences Foundation.

also form a channel to predict noise or perturbations in real-time or in near real-time. The limitations on beam separation are determined experimentally.

## 0 Introduction

Air is not a uniform nor steady-state medium. In fact, the effect of air perturbation was first discovered by using an interferometer. The interference system proposed by H. Fizeau in 1862 is shown in Fig. 1. In this diagram, the interferometer consists of plane glass T and reflector B, and G represents a block gauge to be measured.

The most important feature of this system is its "common path". The upper surface of G and lower surface of T form a group of interference fringes; likewise, the lower surface of T and upper surface of B constitute a group of interference fringes as well. Because of the common-path feature, the changes occurring above T have no effect on fringe distribution, which is commonly accepted as the core of the "common path" principle in the interferometer.

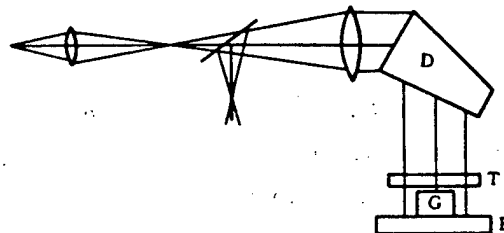

Fig. 1. Fizeau interferometer

Another example of overcoming the effect of air perturbation is phase conjugation. Since the reflected wave is conjugated with the incident wave, its wavefront can be restored to its

original condition when it travels along the old path back to its original point.

Through efforts of succeeding generations of experimenters, adaptive-optics telescopes were eventually developed; these telescopes were designed to improve the quality of star images as affected by atmospheric perturbation. Fig. 2 shows a typical structure of such an adaptive-optics system.

In the diagram, a portion of the beam is split from optical path BS, and wavefront distortions are detected by using a wavefront detector. By manipulation of a controller, the wavefront is corrected with adaptive deformer Add to ensure a clear star image on the image plane. This procedure is the initial purpose of the system designer, which actually was not immediately realized.

The reason for this situation is that it would take a certain time period to accomplish wavefront detection, and to acquire the expected distortion value using a deformable mirror. But before the procedure is completed, a new wavefront has already arrived, whose distortion differs from the wavefront already detected. In this case, although wavefront detection can satisfy the condition of "common path", still, it cannot arrive at the expected outcome. This the reason why prediction technology has been presently applied.

By further analyzing examples of wavefront recovery through phase-conjugation mirrors, it was found that one condition was largely accepted, i.e., the atmospheric state has not yet changed during the time when the beam travels back to the original point.

The foregoing fact suggests that it is inaccurate to interpret the requirement for the optical system simply with the concept "common path", and in many cases, no common path is

possible. In this instance, can one suppress the effect of perturbation in the absence of a complete common path? This is a major concern among specialists in research on optical instruments and optical sensors.

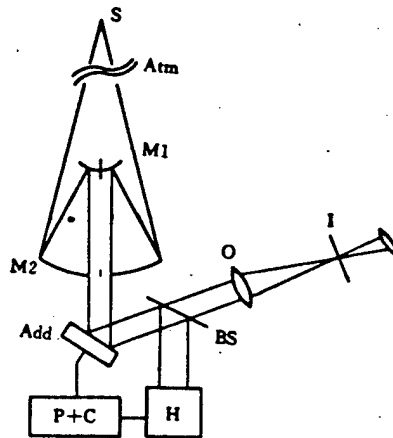

Fig. 2 Principles of adaptive optics  
 KEY: S - star ATM - atmosphere  
 $M_1M_2$  - spherical mirror Add - adaptive device BS - beam splitter H - Hartmann wavefront detector P+C - prediction and control O - object mirror

## 1. Principles of Adaptive Optics

Studies in nonlinear dynamics show[1][2][3] that many substances formerly regarded as random phenomena are actually chaotic and are restricted by nonlinear dynamics. This compelled researchers accustomed to working with "linear" problems not only to modify their habits of thought, but also to examine if their problem-solving procedures are logical. Below are some conclusions relating to optical instruments.

1. Atmospheric perturbations are chaotic.
2. In chaos, long-term predictions are not possible. Yet,

since a determinate dynamical system is involved, short-term predictions are feasible, while random phenomena cannot be predicted. Thus, new opportunities for research on chaos are afforded.

3. The spectral nature of chaos obeys the Kolmogorov distribution ( $1/f^n$  continuous spectrum).

4. The assessment of chaos is Lyapunov-exponentially greater than zero.

Since chaos is characterized by exponential divergence for the initial condition, it is necessary to have the beam to be measured lie in a path common to the reference beam and to convey similar information about perturbation in prediction and compensation. However, if the time needed for prediction and compensation exceeds the limits of short-term prediction (roughly of the order of milliseconds in magnitude), the compensation will be ineffective.

Still, since the spectral nature of chaos is neither "white" noise, nor Gaussian distribution, it is definitely useless to attempt to reduce air perturbation by using the multiple average method.

To raise the design level of optical instruments, based on past experience and on research achievements in nonlinear dynamics, we recommend "adaptive optics" as a fundamental principle for designing optical instruments, i.e., in designing an optical system, it is necessary to design a carrier for the signals to be measured and at the same time, to realize real-time or short-term predication and compensation for noise (perturbation).

The advantage of "adaptive optics" lies in its reality and

fast response, which cannot be replaced by any other sensor. Therefore, in designing optical instruments, noise and perturbation can be better suppressed by carrying out this principle.

This concept, by directly emphasizing the validity of prediction instead of directly requiring vigorous geometric relations, together with the limits on prediction time, appears even more important with regard to signal processing and control systems.

An actual measurement system is more or less offset from the geometric common path, and it becomes an interesting question as to whether or not this offset should also have a limit.

## 2. Research on Wavefront Oblique Correlation of Adjacent Beams

To suppress noise and perturbation, many efficient techniques were adopted in signal processing, such as common-mode suppression, neural net, and adaptive noise-cancellation technique. Yet, the minimum requirement for the predictor and the predicted is that they are correlated to each other.

The purpose of this experiment is to explore whether or not the geometric common path can be made flexible, and if so, how flexible? Accordingly, the criterion is whether or not these two factors are correlated, on which the possibility of prediction is based.

Fig. 3 illustrates the structural principle of the core part of the experimental device. The experiment was conducted under two assumptions, i.e., strong perturbation and "steady state". The Hartmann detector used in this experiment consists of lenses and position-sensitive detectors. The diaphragm apertures  $p_1$  and  $p_2$  are equal in diameter, while lenses  $L_1$  and  $L_2$  are equal in focal

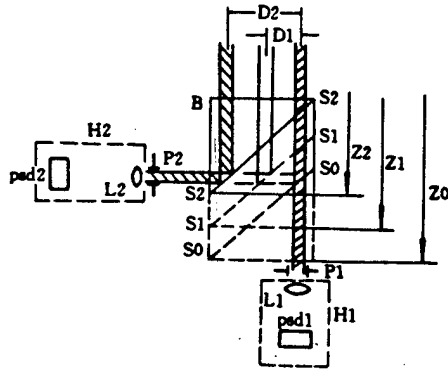

Fig. 3. Experimental device for wavefront correlation of adjacent beams

KEY:  $H_1H_2$  - Hartmann wavefront detector  
 $P_1P_2$  - aperture of diaphragm  
 $L_1L_2$  - lens PSD<sub>1</sub>PSD<sub>2</sub> - position-sensitive device  
 B - 50% beam-splitting prism

length. After accurate calibration of the sensitivity of the two channels, the diaphragm apertures become much smaller than the distance over which the wavefront distortion is spatially coherent. Moreover, the output voltage of the two-dimensional position-sensitive detector can indicate the direction of the wavefront normal line.

The beam-splitting prism, placed on the movable working platform, is driven by a stepper motor. The platform moves in the direction parallel to that of the collimated beam. When the prism is located at  $Z_0$  position, 50% of the beam on the far right is split from its plane  $S_0S_0$  and enters the aperture  $P_2$ , which corresponds to the assumption that two beams lie on a common path.

When the prism is located at position  $Z_1$ , the beam splitting plane moves to  $S_1S_1$  and guides the beam with split value  $D_2$  to  $P_2$ . When the prism is located at position  $Z_2$ , its beam splitting plane reaches  $S_2S_2$  and sends the beam with a split value  $D_2$  to  $P_2$ ... During the entire process, the beam entering  $P_1$  is the beam on the right side. The experimental device does not require readjustments when the beam split values change, which makes the

experiment convenient and repeatable.

### 2.1. Simulation Experiment in Presence of Strong Perturbation

In the collimated optical path above prism B as indicated in Fig. 3, three electric irons are placed just below the beam for baking (of which one is rated at 45W, while the other two are rated at 15W). Then a skip of the beam focused on the position-sensitive detector can be visualized. This simulation can be effective over 50m of actual transmission.

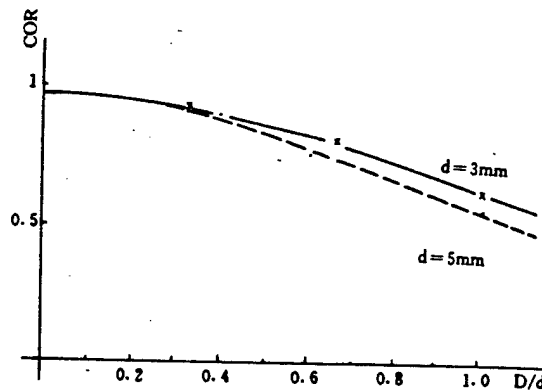

Fig. 4. Wavefront oblique correlation coefficient in presence of strong perturbation

To make better comparison, the following should be defined:

beam split exponent =  $D_i/d$  ( $i=1,2,3\dots$ )

where  $D_i$  is the beam interval (split value) and  $d$  is beam diameter. The light source is a laser; the diagram apertures are designed, respectively, as 3mm and 5mm. The experimental results are shown in Fig. 4. The horizontal coordinate represents the beam split exponent, and the longitudinal coordinate is the corresponding wavefront oblique correlation coefficient (COR); the solid line corresponds to  $d=3\text{mm}$ , and the dashed line corresponds to  $d=5\text{mm}$ .

From Fig. 4, it can be seen that when the split exponent ( $D/d$ ) of these two beams is less than  $1/3$ , their

correlation coefficient is larger than 0.9, and when  $D/d=1$ , these two beams are tangential to each other with a correlation coefficient of approximately 0.5. This result closely matches that of dual-beam collimated compensation[4].

## 2.2. Steady-state Simulation Experiment

In fact, it is impossible to realize a "steady state". The strategy mentioned here is to attempt to remove as many sources of interference as possible, and to place the measurement under automatic control. In this case, even the computer used to collect data must be in another room, and the experiment begins 1h after the instrument has been turned on. The result is shown in Table 1.

TABLE 1

D/d	1 相关系数(COR)			
0	0.80	0.82	0.93	
1/5	0.69	0.78	0.84	0.82
2/5	0.77	0.58	0.67	0.67
3/5	0.76	0.71	0.74	

KEY: 1 - correlation coefficient (COR)

In each test, the sample number is more than 1000 and the sampling is repeated many times. In this experiment, the correlation coefficient fell off sharply and its numerical magnitude varied widely. Yet the actual wave surface deformation was minor. The reason for this is that the properties of the photoelectric devices in the two channels have slight differences.

As a result, some conclusions can be drawn based on the foregoing experiment:

- (1) The geometric common path can be slightly deviated, and

even when  $D/d$  is less than 0.3, the wavefront oblique correlation still remains ideal. During the process when the two beams first are tangential to each other and then are split, the correlation coefficient shows a remarkable decrease.

(2) When electronic devices are involved in the compensatory process, their consistency and symmetry should be well taken into account.

(3) It would be much better if pure optical approaches were applied in the realization of timing prediction and compensation.

### 3. Examples Complying with Adaptive optics Principle

The "adaptive optics" principle can be used in modern optical instrument design to effectively overcome interferences. Additionally, this principle is vitally important in long-distance laser collimation and nanometer measurement techniques, which is illustrated with several successful examples described below.

#### 3.1. Four-Beam and Two-Focus Quasi-Common Path Laser Velocimetry System

A diagram of this system is shown in Fig. 5.  $I_1 I_2 I_3 I_4$  are the four constant-intensity polarized beams split from the polarized beam splitter; of these beams  $I_1$  and  $I_3$  are parallel to each other, and  $I_2$  is parallel to  $I_4$ .  $I_1$  and  $I_2$  include only a small angle, but they are close to each other, and so are  $I_3$  and  $I_4$ .

$I_1-P_{X1}-I_3$  and  $I_2-P_{X2}-I_4$ , respectively, constitute a laser velocimetric channel. Since these two channels are close to each other, the correlation of wave surface deformation is good; here, one channel can offer real-time prediction of the noise from

another channel. In signal processing (comparison phase), the most kinds of noise are mutually offset. As a result, this system can achieve a resolution 100 times higher compared to the conventional technique and reach  $0.03\mu\text{m}$ .

### 3.2 Linear Frequency-Modulation Optical Fiber Sensors of Semiconductor Lasers

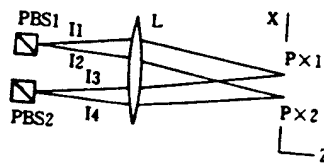

Fig. 5. Four-beam and two-focus quasi-common path system

KEY:  $\text{PBS}_1$   $\text{PBS}_2$  - polarized beam splitter  
 $L$  - object mirror  $P_{X1}$   $P_{X2}$  - beam focus

It is well understood that optical fibers are quite sensitive to factors such as ambient temperature, pressure, vibration, etc. In this fact lies both their advantages and disadvantages. The two beams that induce interference in this system, lie strictly on a common path. Within the range of a small path difference, their measurement accuracy is better than  $0.05\mu\text{m}$ , with its instrument resolution being  $0.02\mu\text{m}$ .

### 3.3 Two-Focus Interference Surface Microscopic Contour Detector

With the help of a birefringent lens, this system can generate two cross-polarized beams; of these beams, one has been collimated, and the other has been focused on the surface to be measured. The collimated beam encloses the focused beam. Strictly speaking, these two beams do not lie in a geometric common path, either. However, since these two beams are close enough to each other, the reference beam still exhibits the capabilities of providing real-time prediction of external

perturbations and is eliminated during signal processing. This system can offer a longitudinal resolution better than 20 angstroms.

#### 4. Conclusions

The "adaptive optics" principle embodies past experience and does not originate with the present authors. This principle has the purpose of upgrading modern optical instrument design. The experimental results given in this paper can be used for reference in design practice. However, due to the widely varying conditions on different occasions, these results cannot be directly applied in any particular case. The experiment introduced in this paper was conducted by the first-named author of this paper, in the laboratory of the electromechanics department, Queens University during his visit to Canada. We are deeply indebted to professor G. J. M. Aitken.

#### REFERENCES

1. Jorgensen, M. B., and G. J. M. Aitken, "Prediction of atmospherically induced wave-front degradations," Optics Letters, 12/7, April 1, (1992), 466-468.
2. Baker, G. L., and J. P. Collub, Chaotic Dynamics: an Introduction, Cambridge University Press (1990).
3. Parker, T. S. and L. O. Chua, "Chaos: A tutorial for engineering," Proceedings of the IEEE, 75/8, Aug. (1987), 982-1008
4. Yin Chunyong, Chen Jijin, and Fang Chongyan, Qinghua University Journal, 31/2 (1991), 55-60.
5. C. Yin, J. Guo, Z. Xu, and Y. Song, "Four-beam two-focus differential laser velocimetry system," Optical Engineering, 31/8, Aug. (1992), 1701-1704.
6. Tian Qian, Li Dacheng, and Zhang Enyue, China Laser, 19/9, Sep. (1992), 668-670.

7. Zhuo Yongmo, Yang Yongying, Xu Min, and Zhang Weiquan,  
Instrument and Metrology Journal, 14/2, May (1993),  
148-153.

This paper was received in July 1933.