

NATIONAL AIR INTELLIGENCE CENTER

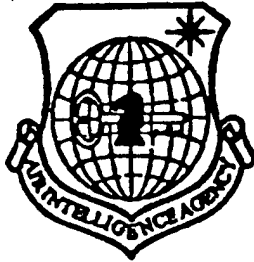

FAST ACQUISITION OF INBOUND SIGNALS
UNDER LOW SIGNAL-TO-NOISE RATIO
CONDITIONS IN RDSS SYSTEMS

by

Ye Fei, Lu Wenfu

DTIC QUALITY INSPECTED 2



19970206 090

Approved for public release:
distribution unlimited



HUMAN TRANSLATION

NAIC-ID(RS)T-0260-96

7 January 1997

MICROFICHE NR:

FAST ACQUISITION OF INBOUND SIGNALS
UNDER LOW SIGNAL-TO-NOISE RATIO
CONDITIONS IN RDSS SYSTEMS

By: Ye Fei, Lu Wenfu

English pages: 19

Source: Zhongguo Kongjian Kexue Jishu (Chinese Space Science
and Technology), Nr. 3, 1991; pp. 24-35

Country of origin: China

Translated by: SCITRAN

F33657-84-D-0165

Requester: NAIC/TASS/Scott D. Feairheller

Approved for public release: distribution unlimited.

THIS TRANSLATION IS A RENDITION OF THE ORIGINAL FOREIGN TEXT WITHOUT ANY ANALYTICAL OR EDITORIAL COMMENT STATEMENTS OR THEORIES ADVOCATED OR IMPLIED ARE THOSE OF THE SOURCE AND DO NOT NECESSARILY REFLECT THE POSITION OR OPINION OF THE NATIONAL AIR INTELLIGENCE CENTER.

PREPARED BY:

TRANSLATION SERVICES
NATIONAL AIR INTELLIGENCE CENTER
WPAFB, OHIO

GRAPHICS DISCLAIMER

All figures, graphics, tables, equations, etc. merged into this translation were extracted from the best quality copy available.

FAST ACQUISITION OF INBOUND SIGNALS
UNDER LOW SIGNAL-TO-NOISE RATIO
CONDITIONS IN RDSS SYSTEMS

Ye Fei Lu Wenfu

Translation of "Shuang Xing Ding Wei Xi Tong Ru Zhan Sin Hao
Zai Di Xin Zao Bi Tiao Jian Xia De Kuai Su Bu Huo"; Chinese
Space Science and Technology, No.3, June 1991, pp 24-35

ABSTRACT Starting out from the angle of the system as a whole, analysis is carried out with regard to various types of fast acquisition methods, setting up simple, clear, and accurate mathematical models. Application is made of these mathematical models to carry out computer simulation analyses of influences on fast acquisition using pseudo random code, Gaussian limit band noise, and Doppler frequency shift. A number of quantitative and qualitative conclusions are obtained. In conjunction with this, SAW matching filters are indicated as an optimal selection. Besides this, theoretical analyses are also carried out with regard to RDSS standard inbound signal pseudo code synchronous patterns. In conjunction with this, one type of possible acquisition method was conceived.

SUBJECT TERM RDSS system PN code acquisition Mathematical model Matched filter Analyzing

I. INTRODUCTION

Dual satellite positioning systems (RDSS) are ones that carry out range finding through measuring transmission delay times associated with inbound signals transmitted by users. The characteristics of inbound signals are as follows.

- (1) Direct sequence expansion (pseudo code length $2^{17} - 1$)
- (2) Short bursts (length $\leq 80\text{ms}$)
- (3) Low signal to noise ratios ($S/N = -22\text{dB}$).

Systems require that central stations will accomplish PN code acquisition of these signals within 0.5ms periods of time. This use of conventional acquisition methods (for example, sliding correlations, sequenced search, sequenced detection, sequenced estimates, and so on) is one that cannot be realized. The methods discussed in this article are to place comparatively short synchronicity guidance sequences (synchronicity headers) in front of long codes. Receivers first carry out fast acquisition of this short code. After that, on the basis of relative phase relationships between short codes and long codes, initial phases are set in long code generators. In conjunction with this, tracking is initiated with regard to long codes. Because of this, the problem of fast acquisition of inbound code becomes a detection problem with regard to synchronicity header pseudo code.

II. ACQUISITION OF SYNCHRONICITY HEADER PSEUDO CODE

Fig.1 is the synchronicity header format suggested by the RDSS international technology coordination committee. This type of special structural design will achieve requirements associated with the five areas below.

- (1) Collision probabilities when multiple users arrive at the same time are as small as possible.

- same time are as small as possible.
- (2) User equipment (that is, user receivers) are simple. /25
 - (3) Guarantees of partial interrelationships are bounded.
 - (4) Guarantees of adequately high synchronous acquisition probabilities (under conditions of a certain false alarm probability).
 - (5) There cannot be time fuzziness.

These requirements above are not mutually independent of each other, but are mutually connected and mutually restraining.

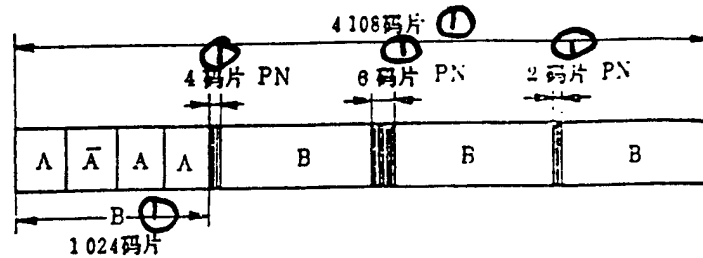

Fig.1 RDSS ITCC Recommended Synchronicity Header Structure (1) Code Fragment

As far as carrying out in real time acquisition requirements with regard to B sequences is concerned, the only way to be able to realize it is to have matched filters or scroll device type real time correlation components. Fig.2 is one type of possible acquisition design with regard to Fig.1 synchronicity header structure. With respect to this design, there are several points of explanation below.

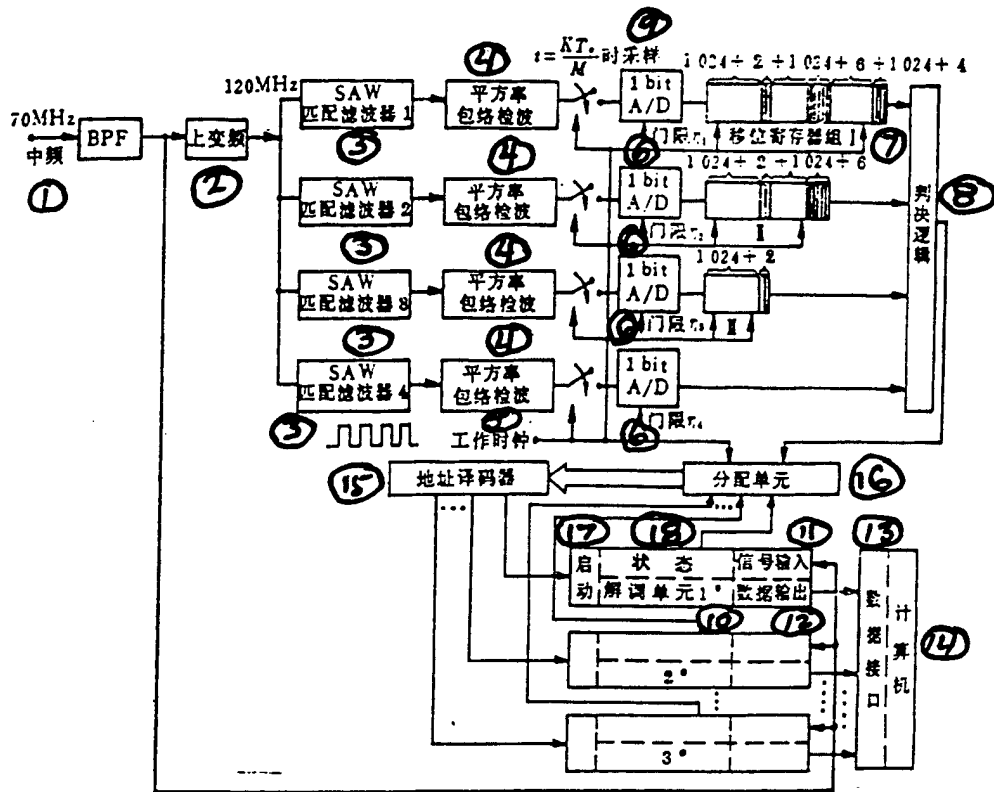

Fig.2 One Type of Possible Design for the Structure of Fig.1 Synchronicity Headers

Key: (1) Intermediate Frequency (2) Upper Change Frequency (3) Matched Filter (4) Square Rate Envelope Detection (5) Operating Clock (6) Gate Limit (7) Shift Register Component (8) Decision Logic (9) Time Sample (10) Demodulation Unit 1 (11) Signal Input (12) Data Output (13) Data Connections (14) Computer (15) Address Decoder (16) Assignment Unit (17) Start (18) Configuration

(1) Threshold values η_1 , η_2 , η_3 , and η_4 can be selected as the same or different in order to satisfy requirements associated with acquisition probabilities and false alarm probabilities.

(2) Sampling rates (operating clock frequencies) should be at least 2 times frequency expansion code speeds. As a result, shift register series in the diagram are also doubled at least once. However, no matter what kind of sampling rate it is, it is necessary in all cases to make shift register set delay times and

signal sustainment times match up with each other.

(3) Decision logic output indications designate a certain free demodulation unit designation through pseudo code initial position times as well as through demodulator assignment units. The outputting of a pulse by address decoder devices turns on demodulators. In conjunction with this, there is activation of initial configuration delay lock rings set into demodulation devices--beginning the carrying out of demodulation and decoding associated with communications pseudo code tracking and information. /26

(4) As far as the simultaneous use of four matched filters is concerned, it is possible to complete acquisition of multiple signals (it is only necessary that the arrival times of these signals be staggered 2 frequency expansion code units or more and it is then possible to separately acquire them).

(5) Due to the fact that there are intervals with different distances between them between B sequences associated with each synchronizer (4, 6, and 2 code fragments), as a result, it is only necessary, at the instant when the final B sequence completely enters into the fourth matched filter, and, in conjunction with that, there is the appearance of a correlation peak, that four decision logic inputs (that is, four sets of parallel shift register outputs) are then all "1". At other times, among the four, at the most, there is only one that was "1" (single user situation). When there is the simultaneous appearance of 2 or 3 "1"s created because of the arrival of multiple user signals at the same time or created due to noise leading to false alarms, signal acquisition will not be influenced in any case. Only when there is the simultaneous appearance of 4 "1"s corresponding to a nonsynchronous configuration, that one has the appearance of erroneous acquisitions--but this type of probability is very small.

(6) If, due to technological causes, there are slight errors created in the lengths of the four matched filters, then, it is possible to make their operations normal through adjusting the shift register series in peripheral circuitry.

III. BASE BAND MATCHED FILTER METHODS

1. Basic Assumptions

In the discussions that follow, the assumptions below are made with regard to signals and noise.

Signal Channels Additive limit bands are Gaussian signal channels. Band widths are $B = 2R_c$.

Reception signals $r(t) = s(t) + n(t)$

In this, $s(t) = \sqrt{2s}P(t) \cos(\omega_s t + \omega_c t + \phi)$. This is a synchronicity head pseudo code signal.

$$P(t) = \sum_{n=1}^N a_n V_n(t - nT_c) \quad \text{is pseudo code base band}$$

signals for the same frequencies.

$a_n = \pm 1, n=1, 2, \dots, N$ are pseudo code sequences.

$N=1024$ is pseudo code length.

$$V_c(t) = \begin{cases} 1 & -T_c < t < 0 \\ 0 & \text{Other} \end{cases}$$

ω_0 is center frequency.

$T_c = 1/R_c$ are pseudo code cycles. Pseudo code speeds $R_c = 8\text{Mbit/s}$.

s is received signal power. $ST_b = E_b =$ unit bit energy.

Information code speed $R_b = 15.625\text{kbit/s}$. $T_b = 1/R_b$.

ω_d is Doppler frequency shift. $\omega_d \leq 2\pi \times 2 \times 10^3$.

Frequency expansion coefficient $G = T_b/T_c = 512$.

ϕ random phase angle.

Noise $n(t)$ is a limit band Gaussian random process. Single side power spectrum density is N_0 . Band width $B = 2R_c$. $n(t)$ can be orthogonally resolved into the sum of two independent low pass type Gaussian processes $n_c(t)$ and $n_s(t)$, that is

$$n(t) = n_c(t)\cos \omega_0 t - n_s(t)\sin \omega_0 t$$

$n_c(t)$ and $n_s(t)$ are independent base band Gaussian white noise. The power spectrum density value is N_0 . /27

2. Principles of Base Band Matched Filter Methods and Equivalent Mathematical Models

This type of method is to take received intermediate frequency signals and respectively transform them into two orthogonal paths, carrying out matched filtering on base bands. After this, the two outputs are then taken and square sum operations are carried out, obtaining full statistical quantities. Finally, gate limit decisions are carried out. The line and block chart of the principles is as shown in Fig.3.

(1) Multiple Signal Models

Assume that received signals are

$$r(t) = s(t) + n(t)$$

$$s(t) = \sqrt{2s}P(t)$$

$$\cos(\omega_s t + \omega_s t + \phi);$$

$$n(t) = n_c(t)\cos(\omega_s t + \phi)$$

$$- n_s(t)\sin(\omega_s t + \phi)$$

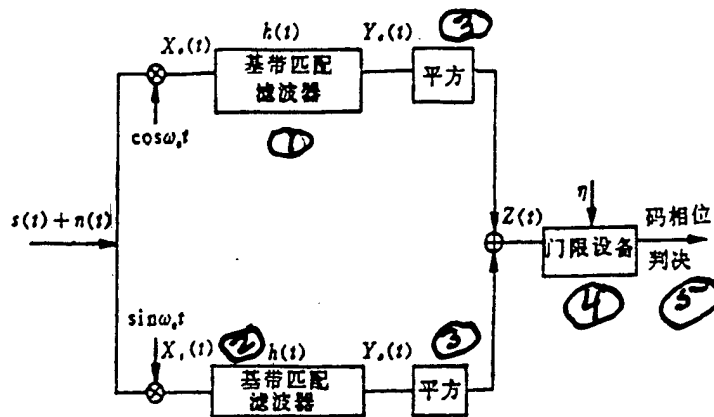

Fig.3 Schematic of Base Band Matched Filter Principles

Key: (1) Base Band Matched Filter (2) Base Band Matched Filter
 (3) Square (4) Gate Limit Equipment (5) Code Phase Determination

Base band matched filter impact excitation influence is:

$$h(t) = \begin{cases} \sqrt{2/T} P(T-t) & 0 < t < T \\ 0 & \text{otherwise} \end{cases}$$

In this, $T = NT_c = 1.024T_c$.

$h(t)$ is a similar low pass filter. Ignoring high frequency terms, outputs after frequency alterations are as follows.

$$\begin{aligned} X_c(t) &= [s(t) + n(t)] \cos \omega_c t \\ &\approx \left(\frac{\sqrt{2s}}{2}\right) P(t) \cos \omega_c t \cos \phi - \left(\frac{\sqrt{2s}}{2}\right) P(t) \sin \omega_c t \sin \phi \\ &\quad + \left[\frac{n_c(t)}{2} \cos \phi - \frac{n_s(t)}{2} \sin \phi \right] \\ X_s(t) &= [s(t) + n(t)] \sin \omega_c t \\ &\approx -\left(\frac{\sqrt{2s}}{2}\right) P(t) \sin \omega_c t \cos \phi - \left(\frac{\sqrt{2s}}{2}\right) P(t) \cos \omega_c t \sin \phi \\ &\quad + \left[-\frac{n_c(t)}{2} \sin \phi - \frac{n_s(t)}{2} \cos \phi \right] \end{aligned}$$

$$\begin{aligned}
Y_c(t) &= \left(\frac{\sqrt{2s}}{2}\right)P(t)\cos\omega_d t \cdot h(t)\cos\phi - \left(\frac{\sqrt{2s}}{2}\right)P(t)\sin\omega_d t \cdot h(t)\sin\phi \\
&\quad + \frac{1}{2}[n_c(t) \cdot h(t)]\cos\phi - \frac{1}{2}[n_s(t) \cdot h(t)]\sin\phi \\
Y_s(t) &= -\left(\frac{\sqrt{2s}}{2}\right)P(t)\sin\omega_d t \cdot h(t)\cos\phi - \left(\frac{\sqrt{2s}}{2}\right)P(t)\cos\omega_d t \cdot h(t)\sin\phi \\
&\quad - \frac{1}{2}[n_c(t) \cdot h(t)]\sin\phi - \frac{1}{2}[n_s(t) \cdot h(t)]\cos\phi \\
Z(t) &= Y_c^2(t) + Y_s^2(t)
\end{aligned}$$

Simplifying, one gets

$$Z(t) = |[\vec{s}(t) + \vec{n}(t)] \cdot h(t)|^2$$

/28

In this,

$$\begin{aligned}
\vec{s}(t) &= \left(\frac{\sqrt{2s}}{2}\right)P(t)\exp(j\omega_d t) \\
\vec{n}(t) &= \frac{1}{2}n_c(t) - j\frac{1}{2}n_s(t)
\end{aligned}$$

Equivalent multiple signal models are as shown in Fig.4.

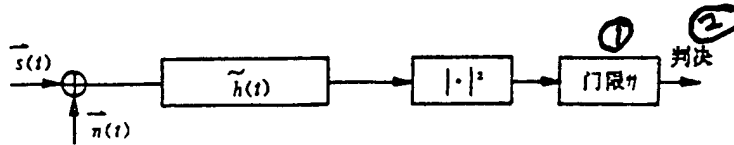

Fig.4 Equivalent Multiple Signal Model (1) Gate Limit (2) Determination

From the Fig., it can be seen that random phase difference ϕ has been eliminated. This is a type of noncoherent detection method. As far as Doppler shift equivalents in multiple signals are concerned, their influences on performance are not simple, precisely determined functional relationships.

(2) Pseudo Code Matched Filter Discrete Time Domain Analysis

The influences of Doppler frequency shifts remain in the considerations that follow. First, let $\omega_d = 0$.

$$s(t) = \frac{\sqrt{2s}}{2} \sum_{n=1}^N a_n V_c(t - nT_c)$$

$$Y(t) = |[s(t) + n(t)] \cdot h(t)|^2$$

$$= [X(t) + n_1(t)]^2 + n_2^2(t)$$

The influences of wave filters on signals

$$X(t) = s(t) \cdot h(t)$$

$$= \sqrt{\frac{s}{T_c}} \sum_{n=1}^N \sum_{l=1}^N a_n b_l \int_{-\infty}^{\infty} V_c(Z - nT_c) V_c(t - Z - lT_c) dZ$$

$$= \sqrt{E_s} G^{-1} \sum_{k=1}^{2N} C_k r_c(t - kT_c)$$

In this, $r_c(t) = \frac{1}{T_c} [V_c(t) \cdot V_c(t)]$, . It is a triangular wave single pulse associated with a pulse width of $2T_c$. $r_c(\pm T_c) = 0$. $r_c(0) = 1$.

$$C_k = \begin{cases} \sum_{l=1}^{k-1} a_{k-l} b_l & k \leq N+1 \\ \sum_{l=k-N}^N a_{k-l} b_l & k \geq N+1 \end{cases}$$

With regard to situations associated with pseudo code matching of filter pseudo codes and input signals, $b_n = a_{N+1-n}$. At this time, C_k , when $k=N+1$, takes a maximum value of 1 024. In conjunction with this, corresponding correlation peaks appear.

The influences of filters on noise are:

$$n_1(t) = \frac{1}{2} n_c(t) \cdot h(t)$$

$$n_2(t) = \frac{1}{2} n_s(t) \cdot h(t)$$

As far as Gaussian process output $n_1(t)$ --after going through linear filters--is concerned, $n_2(t)$ is still a Gaussian process. The reason is that $n_c(t)$ and $n_s(t)$ are independent. Therefore, $n_1(t)$ and $n_2(t)$ are also independent. Moreover, their statistical characteristics are completely the same. As a result, analysis is only done on $n_1(t)$ and that is all. From $n_c(t)$ power spectrum

density functions, it is easy to obtain the correlation functions. /29

$$Rn_c(\tau) = 2R_c N_o [\text{SINC}(2\pi R_c \tau)]$$

When $Rn_c(\tau)$ at $\tau = \frac{1}{2R_c} = \frac{T_s}{2}$, $Rn_c(\tau)$ is zero. That is, when sampling is done using $f_s = 2R_c$ frequencies, there is mutual independence between sampling values. This is for nothing else than the convenience it brings to time domain analysis.

$$Z_c(n) = n_1(t = nT_s) = \frac{T_s}{2} \sqrt{\frac{2}{T_s}} \sum_{i=1}^{2N} n_c((n-1)T_s) b_{i+1}$$

The reason is that $n_c(nT_s)$ is a mutually independent Gaussian random sequence. Therefore, $Z_c(n)$ is a mutually independent Gaussian random sequence. By the same reasoning, $Z_s(n) = n_2(t = nT_s)$.

Moreover, $Z_c(n)$ and $Z_s(n)$ are independent. One then has

$$Z_c(n) = n_1(t = nT_s)$$

$$Z_s(n) \text{ 与 } Z_c(n) \text{ 独立}$$

$$E[Z_c(n)] = E[Z_s(n)] = 0$$

Therefore,

$$E[n_1^2(n)] = E[n_2^2(n)] = N.$$

$$Y(nT_s) = \left[\sqrt{E_b} G^{-1} \sum_{i=1}^{2N} C_{kr} n_1(nT_s - kT_s) + Z_c(n) \right]^2 + Z_s^2(n)$$

With regard to each sampling time, $Y(nT_s)$ adopted value probability distributions--when synchronicity heads arrive--obey χ square distributions associated with deviation centers. The distribution density function is

$$P(y) = \begin{cases} 1/(2\sigma^2) \exp(-y/2\sigma^2 + \gamma) I_0(2\sqrt{\gamma y/2\sigma^2}) & y \geq 0 \\ 0 & \end{cases}$$

In this, $\gamma = (\sqrt{E_b} G^{-1} C_k)^2 / 2N_o$ is signal to noise ratios before detection-- $\sigma^2 = N_o$. When there is no arrival of synchronicity heads, a standard χ square distribution is obeyed. This distribution density function is

$$P(y) = \begin{cases} 1/2\sigma^2 \exp(-y/2\sigma^2) & y \geq 0 \\ 0 & \end{cases}$$

Using these formulae to derive detection probabilities and false alarm probabilities will be unable to obtain a closed analytical solution. Therefore, we used numerical value analytical methods on 386 microcomputers to carry out simulations, analysis, and calculations with regard to full statistics associated with $Y(nT_s)$. Fig.5 gives sample sequences under various types of signal

to noise ratios. Fig.6 gives sample sequences corresponding to different pseudo code code types.

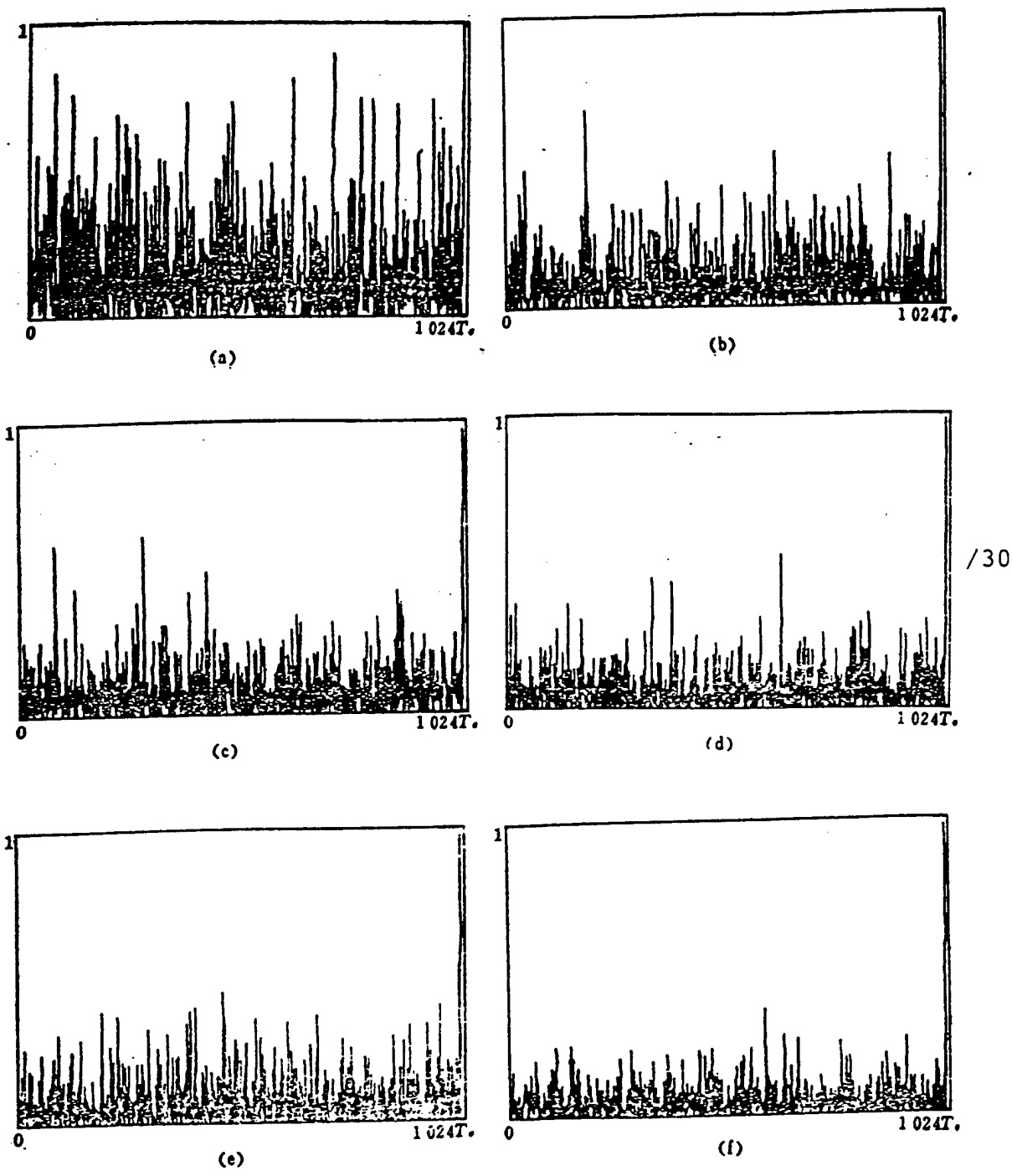
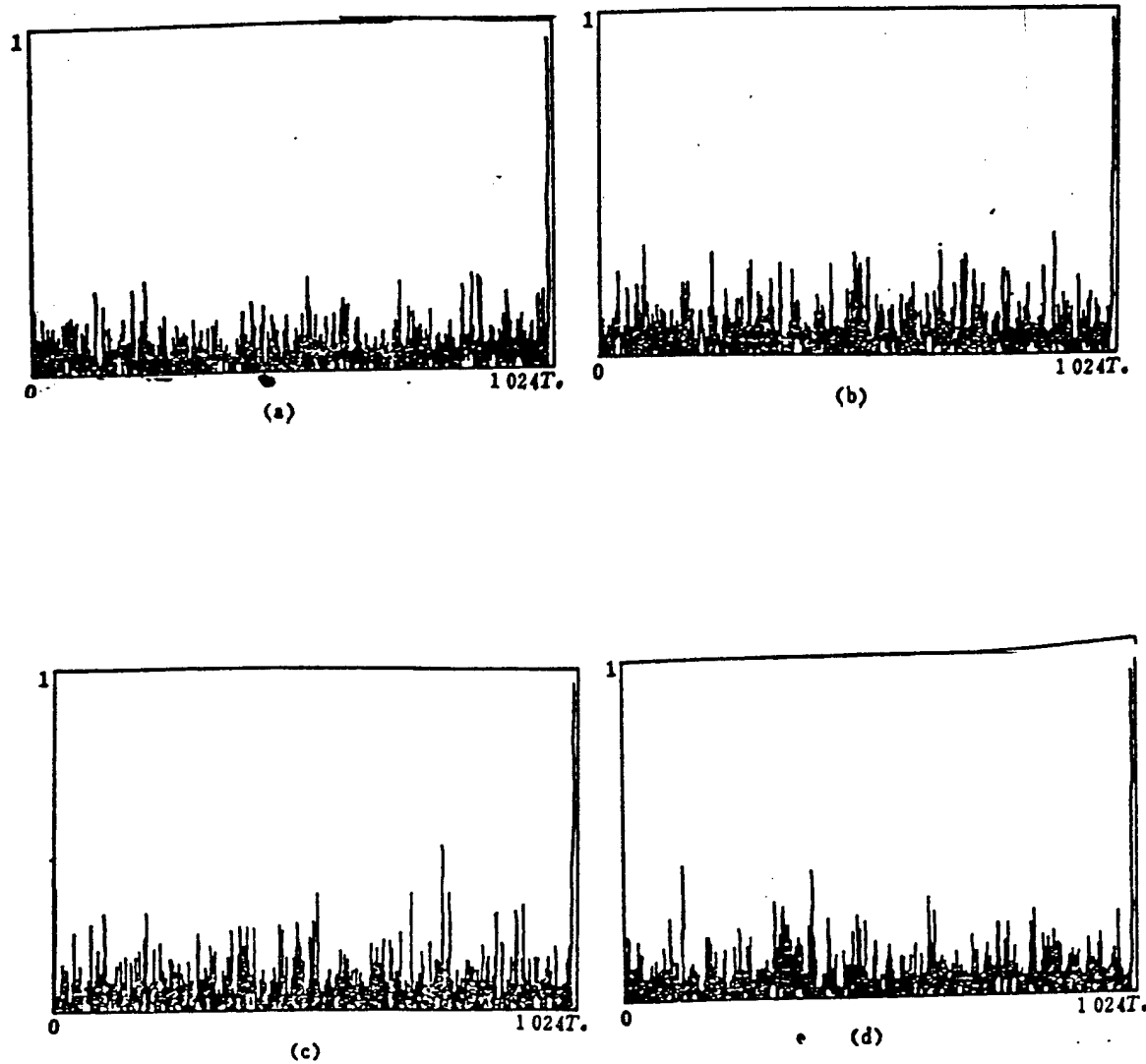

Fig.5 Sample Sequences Under Various Types of Signal to Noise Ratios $A=2^{17} - 1$ Gold Code Partial Sequence $\overline{A} = -A$
 (a) $E_b/N_o = 4.0\text{dB}$, (b) $E_b/N_o = 5.0\text{dB}$, (c) $E_b/N_o = 6\text{dB}$,
 (d) $E_b/N_o = 7\text{dB}$, (e) $E_b/N_o = 7.5\text{dB}$, (f) $E_b/N_o = 8.0\text{dB}$.



/31

(a) $A=2^{17}-1$ Gold 码部分序列 $\bar{A}=-A$, $E_b/N_0=8.0\text{dB}$; (b) $A=2^{17}-1$ Gold 码部分序列 $\bar{A}=A$ 的时间翻转, $E_b/N_0=8.0\text{dB}$; (c) $A=2^{17}-1$ Gold 码部分序列 $\bar{A}=A$, $E_b/N_0=8.0\text{dB}$; (d) $B=1024\text{m}$ 序列, $E_b/N_0=8.0\text{dB}$.

Fig.6 Sample Sequences Corresponding to Different Pseudo Code Code Types

Key: (1) Code Partial Sequence (2) Time Inversion (3) Sequence

Sequence

Besides this, numerical value calculations by computer give acquisition probabilities for single 1024 place B sequences as shown in Fig.4.

(3) Influences of Doppler Frequency Shifts

From equivalent complex mathematical models, it is possible to derive outputs under conditions where Doppler frequency shifts exist

$$X(t) = \sqrt{E_s} G^{-1} \sum_{k=1}^{2N} C_k r_c(t - kT_c)$$

In this,

$$C_k = \begin{cases} \sum_{l=1}^{k-1} a'_l - i b_l & k \leq N+1 \\ \sum_{l=k-N}^N a'_l - i b_l & k \geq N+1 \end{cases}$$

Moreover,

$$a'_l = a_l \exp(jn\omega_d T_c), \quad b_l = a_{N+1-l}$$

As a result, the effects of Doppler frequency shifts are approximately equivalent to inputting pseudo code sequences weighted by $\exp(-jn\omega_d T_c)$. Moreover, there are transformations into complex sequences. In this way, the influences of Doppler frequency shifts on outputs are mixed together with noise.

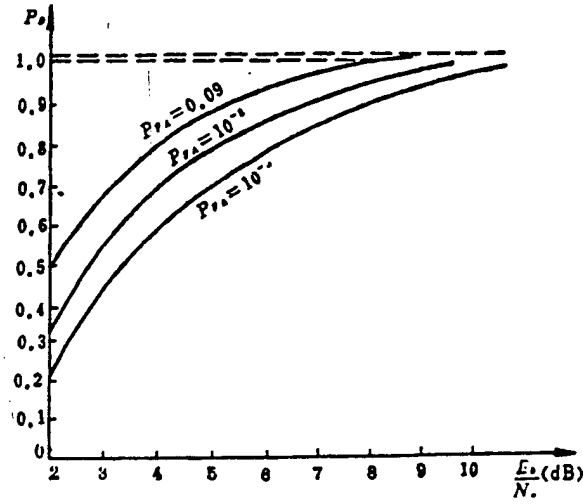

Fig.7 Acquisition Probabilities Associated with Single 1024 Place B Sequences

(1) Influences of Doppler Frequency Shifts on Output Sampling Sequences

$$Y(nT_s) = \left[\sqrt{E_s} G^{-1} \sum_{i=1}^{2N} D'_i r_c(t - kT_s) + Z_s(n) \right]^2 + \left[\sqrt{E_s} G^{-1} \sum_{i=1}^{2N} S'_i r_c(t - kT_s) + Z_s(n) \right]^2$$

In this,

$$D'_k = \begin{cases} \sum_{i=1}^{k-1} g_{k-i} b_i & k \leq N+1 \\ \sum_{i=k-N}^N g_{k-i} b_i & k \geq N+1 \end{cases}$$

$$g_n = a_n \cos(n\omega_s T_s), \quad b_n = a_{N+1-n}$$

/32

$$S'_k = \begin{cases} \sum_{i=1}^{k-1} g'_{k-i} b_i & k \leq N+1 \\ \sum_{i=k-N}^N g'_{k-i} b_i & k \geq N+1 \end{cases}$$

$$g'_n = a_n \sin(n\omega_s T_s), \quad b_n = a_{N+1-n}$$

The definition is made that

$$C_i = \sqrt{D_i^2 + S_i^2}$$

Not considering cross modulation between signal and noise, it is then possible for it to represent Doppler frequency shift influences on signal sequences.

Fig.8 gives maximum permissible 2kHz Doppler frequency shift influences on C_i . From the Fig., it is possible to see pseudo code correlation function deterioration created by Doppler frequency shifts. Relative distances between secondary peaks and main peaks are shortened.

(2) Doppler Frequency Shift Influences on Main Correlation Peaks

Only considering the influences that signal correlation peaks themselves are subject to from Doppler frequency shifts:

$$Y(t) = \left[\left[\frac{\sqrt{2s}}{2} P(t) \exp(-j\omega_d t) \right] \cdot \left[\sqrt{\frac{2}{T_b}} P(T-t) \right] \right]^2$$

When $t=T=NTc$, corresponding main correlation peaks appear.

$$Y(T) = |2\sqrt{E_s}|^2 \text{SINC}^2(\omega_d T_b)$$

The definition is made that $\epsilon(\omega_d T_b) = \text{SINC}^2(2\pi f_d / R_b)$.

Fig.9 gives a relationship curve and data with regard to main correlation peak drop dB numbers associated with Doppler frequency shift normalizations of information rate R_b . From the Fig., it is possible to see that, when Doppler frequency shift is (the maximum permissible) $\pm 2\text{kHz}$, main correlation peak drops of 0.912dB are equivalent to signal energy losses of 0.912dB.

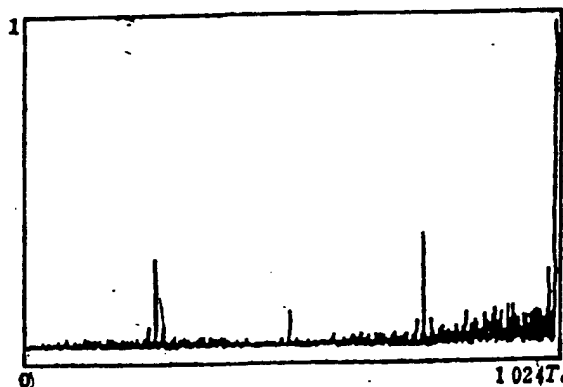

Fig.8 Influences of Doppler Frequency Shifts on C_i

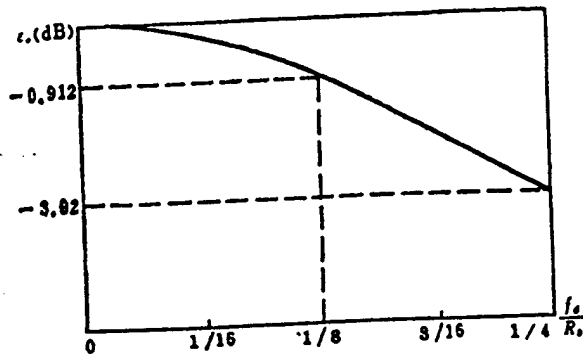

Fig.9 $f_d/R_b - \epsilon_0$ (Main Correlation Peak Value) Curve

3. Ways of Realizing Base Band Matched Filters

(1) Discrete Forms of Base Band Matched Filters

Not considering series perturbations between code and distortion created by limit bands, frequency changes achieving base band signals are:

$$S(t) = \sum_{n=1}^N a_n V_n(t - nT_0)$$

Assuming that the impact excitation influences of matched filters are $h(t)$, they are in direct proportion with time inverses associated with pseudo code designs requiring matching. That is, /33

$$h(t) = \begin{cases} S(T-t) & 0 < t < T \\ 0 & \text{otherwise} \end{cases}$$

In this, T is filter time length. $T = NT_0 = 1.024T_0$.
 Assuming input signal $X(t) = S(t) + n(t)$,
 then, matching filter output is

$$Y(t) = X(t) \cdot h(t)$$

$$= \sum_{n=1}^N a_n \int_{(n-1)T_c}^{nT_c} X(t+Z-NT_c) dZ$$

Considering sampling values associated with instants $t = NT_c + kT_c/M$, in this, $K=0, 1, 2, \dots$. At this time, sampling rates are M times frequency expansion code speeds.

$$Y((N+k/m)T_c) = \sum_{n=1}^N a_n \int_{(n-1)T_c}^{nT_c} X(NT_c + kT_c/m + Z - NT_c) dZ$$

$$= \sum_{i=1}^{MN} D_i X_{i+k}$$

In this,

$$X_i = \int_{(i-1)\frac{T_c}{M}}^{i\frac{T_c}{M}} X(\xi) d\xi$$

D_i is positive and negative polarity associated with the i th base chip. Its relationship with pseudo code a_n is

$$D_{(n-1)M+i} = a_n \begin{cases} i=1, 2, 3, \dots, M \\ n=1, 2, 3, \dots, N \end{cases}$$

(2) Ways of Realization

Above we have derived the discrete forms associated with base band matched filters. Because of this, it is possible to construct two types of realization methods. One type is analog plug delay line realized in association with CCD devices. The other type is digital transverse filter devices realized in association with digital shift register stacks. These two types are both zero intermediate frequency (base band) matched filter methods. When they carry out detection with regard to synchronicity header pseudo code, orthogonal break down of carrier waves is first carried out. Then, pseudo code matched filtering is carried out. Due to the fact that frequency expansion signal carrier wave information is hidden in noise, as a result, phase differences between local carrier waves and signal carrier waves are random variables in uniform distributions $(0, 2\pi)$. Outputs associated with matched filters on the two orthogonal loops must go through square sum operations. Only then is it possible to eliminate this random phase difference.

As far as the advantages of null intermediate frequency matched filter methods are concerned, it is possible to realize fully digital fast acquisition systems. However, one of the drawbacks is that sampling times have very large influences on performance. In order to select optimal sampling points, sampling rates must be made higher than frequency expansion code speeds by

one fold or more. As a result, matched filter correlation lengths must also increase by at least one fold. Operational clock frequencies also increase at least one fold correspondingly. In this way, such problems as increases in matched filter series, power consumption also increasing, and so on, are brought in.

IV. INTERMEDIATE FREQUENCY MATCHED FILTER METHODS

Intermediate frequency matched filter methods are the carrying out, in intermediate frequencies, of matched filtering on received signals. After that, noncoherent detection is then carried out. The line and block chart of the principles is as shown in Fig.10.

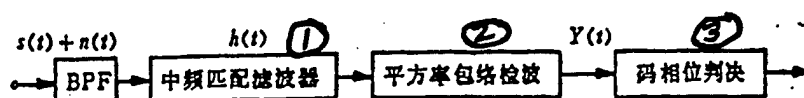

Fig.10 Line and Block Chart for Intermediate Frequency Matched Filter Method Principles

Key: (1) Intermediate Frequency Matched Filter (2) Square Rate Envelope Detection (3) Code Phase Determination

/34

1. Base Band Equivalent Mathematical Models

Parameters are assumed to be the same as in III. Let

$$s(t) = P(t) \cos(\omega_s t + \omega_c t + \phi)$$

$$h(t) = h_o(t) \cos \omega_s t$$

In this, $h_o(t)$ is the base band equivalent associated with $h(t)$.

$$n(t) = n_c(t) \cos(\omega_s t + \phi) - n_s(t) \sin(\omega_s t + \phi)$$

Eliminating high frequency terms and, in conjunction with that, simplifying,

$$\begin{aligned}
s(t) \cdot h(t) &= \{1/2[P(t) \cos \omega_c \tau] \cdot h_s(t)\} \cos(\omega_c t + \phi) \\
&\quad - \{1/2[P(t) \sin \omega_c \tau] \cdot h_s(t)\} \sin(\omega_c t + \phi) \\
n(t) \cdot h(t) &= [1/2n_c(t) \cdot h_s(t)] \cos(\omega_c t + \phi) \\
&\quad - [1/2n_s(t) \cdot h_s(t)] \sin(\omega_c t + \phi) \\
Y(t) &= |[1/2P(t) \exp(-j\omega_c t) + 1/2n_c(t) - 1/2n_s(t)] \cdot h_s(t)|^2 \\
&= |[\vec{s}(t) + \vec{n}(t)] \cdot h_s(t)|^2 \\
\vec{s}(t) &= 1/2P(t) \exp(-j\omega_c t) \\
\vec{n}(t) &= \frac{1}{2} n_c(t) - j\frac{1}{2} n_s(t)
\end{aligned}$$

From this, it is possible to see that base band equivalent complex signal models obtained are completely the same as base band matched filter equivalent forms derived in the sections above. As a result, the conclusions associated with the sections above are set up in the same way here--that is, theoretically speaking--intermediate frequency matched filter performance is completely the same as base band matched filters.

2. Sonic Apparent Wave (SAW) Devices Realize Intermediate Matched Filters

SAWD used in frequency expansion systems primarily include SAW plug delay lines and SAW scroll devices. SAWD acting as intermediate frequency matched filters are one type of most important path associated with fast pseudo code acquisition technology at the present time. We have already taken this type of method and applied it in tests. In conjunction with this, success has been achieved.

In the writing of this article, guidance has been received from Professor Tong Kai. The authors express their gratitude for this.

REFERENCES

- 1 Martin A Rothblatt, Radiodetermination Satellite Services and Standards, 1987.
- 2 Marvin K S, et al, Spread Spectrum Communication, 1985.
- 3 R. C. 狄克逊. 扩展频谱系统. 国防工业出版社, 1982.
- 4 Joseph H Yuen, Deep Space telecommunications Systems, 1985.
- 5 吴中一等著. 伪随机序列技术. 哈尔滨工业大学出版社, 1986.
- 6 Kowatsch M, Synchronization in a spread spectrum communication Modem Based an SAW convolvers, Proc. IEEE Military Communications Conference, 1984, 125~130
- 7 Kowatsch M, Burst Communication Modem Based on SAW Elastic Convolvers, IEEE Ultrasonic Symp, Proc, 1982, 262~267
- 8 Morgan D F and Hannach J M, Surface wave recirculation loops for Signal processing, IEEE trans, Sonics and Ultrason, SU-25, 1978, 30~42
- 9 Hjelmstad J and Skaug R, Fast Synchronization Modem for Spread Spectrum Communication System Using Burst—Format Message Signalling, IEEE Proc, Vol, 128, Pt, F, 1981, 370~378
- 10 Brodtkorb D and Lagnor J E, Fast Synchronization in a Spread Spectrum System Based on acoustoelectric convolvers, IEEE Ultrason, Symp, 1978, 561~566
- 11 Kowatsch M, Design of a convolvers-based packet voice Spread spectrum system, IEEE Ultrason, Symp, 1984, 127~131