

# NATIONAL AIR INTELLIGENCE CENTER



LARGE TIME-BANDWIDTH PRODUCT PROCESSING OF SIGNALS  
IN SPREAD-SPECTRUM COMMUNICATIONS

by

Xu Zongze, Qian Tianming



DTIC QUALITY INSPECTED 2

19970206 094

Approved for public release:  
distribution unlimited



**HUMAN TRANSLATION**

NAIC-ID(RS)T-0256-96            7 January 1997

MICROFICHE NR:

LARGE TIME-BANDWIDTH PRODUCT PROCESSING OF SIGNALS IN  
SPREAD-SPECTRUM COMMUNICATIONS

By: Xu Zongze, Qian Tianming

English pages: 19

Source: Tongxin Xuebao (Journal of China Institute of  
Communications), Vol. 13, Nr. 1, January 1992;  
pp. 8-16

Country of origin: China

Translated by: SCITRAN  
F33657-84-D-0165

Requester: NAIC/TASS/Scott D. Fairheller

Approved for public release: distribution unlimited.

THIS TRANSLATION IS A RENDITION OF THE ORIGINAL  
FOREIGN TEXT WITHOUT ANY ANALYTICAL OR EDITO-  
RIAL COMMENT STATEMENTS OR THEORIES ADVOC-  
ATED OR IMPLIED ARE THOSE OF THE SOURCE AND  
DO NOT NECESSARILY REFLECT THE POSITION OR  
OPINION OF THE NATIONAL AIR INTELLIGENCE CENTER.

PREPARED BY:

TRANSLATION SERVICES  
NATIONAL AIR INTELLIGENCE CENTER  
WPAFB, OHIO

GRAPHICS DISCLAIMER

All figures, graphics, tables, equations, etc. merged into this translation were extracted from the best quality copy available.

LARGE TIME-BANDWIDTH PRODUCT PROCESSING OF SIGNALS  
IN SPREAD-SPECTRUM COMMUNICATIONS

Xu Zongze Qian Tianming

Translation of "Kuo Pin Tong Xin Zhong Xin Hao De Da Shi Dai Ji Chu Li"; Journal of China Institute of Communications, Vol.13, No.1, January 1992, pp 8-16

ABSTRACT This article describes the basic principles of an SAW recirculating delay line integrator (RLI). In conjunction with that, the performance is discussed. Finally, computer simulation and testing results are given.

## I. INTRODUCTION

Spread spectrum technology is the expansion of signal energy to frequency band ranges which are much wider than signal band widths, causing signals to be buried in noise. As a result, spread spectrum technology possesses outstanding performance in association with security, counter jamming, and counter intercept. At receiving terminals, through correlation processing, signal energies are made to concentrate--restoring original signals. In direct spread systems, the ratio of signal expansion band widths and signal band widths is defined as the processing gain. Processing gain is an extremely important parameter. The theoretical value is  $10\log N$  ( $N$  is code length). The longer direct sequence psuedo codes are, the higher processing gains are. Then, the larger counter jamming tolerances are. The more numerous the numbers of PN codes which can be made use of are, the better security characteristics can be and the more advantageous to counter intercept. Therefore, any type of spread spectrum technology is attempting strenuously to raise processing gains in all cases. When opting for the use of SAW devices as correlation processors, due to the fact that they are subject to limitations associated with the technological conditions of the devices themselves, it is not possible to obtain very high processor gains. That is also nothing else than to say that SAW device intrinsic time band width products limit processor gain increases. For instance, under typical low signal to noise ratio conditions, processing gains associated with satellite signal channel receivers are higher than 30dB. Using single SAW devices in order to realize this is difficult. How to make entire systems achieve large processing gains is clearly very important. It is possible to opt for the use of time domain section processing or frequency domain section processing methods in order to resolve this. This article only studies the former method as well as analyzing its performance. At the same time, it gives test results. The results have been used in dual satellite rapid positioning and communications systems.

## II. SAW DEVICE TIME BAND PRODUCT (TB)

Due to the fact that processing gain is a very important technological index, in spread spectrum systems, every effort is made to obtain high processing gains. If receivers opt for the use of matched filters to carry out correlation processing, in that case, SAW convolvers and SAW plug time delay lines are ideal matched filters. The size of SAW matched filter time band width product (TB) and processing gains are intimately related. However, TB values are certainly not equal to processing gain ( $G$ ). They only stand for corresponding values which processing gains are capable of reaching. Table 1 shows the relationship of  $G$  and TB's intrinsic to SAW devices.

-----  
 Xu Zongze: Assistant Professor at Nanjing Aviation Institute  
 Electronics Engineering Department. Deputy Department Chair.  
 Graduated Nanjing Aviation Institute Electronics Engineering  
 Department in 1964. Currently engaged in teaching and scientific  
 research work in the area of radio communications.  
 -----

/9

Table 1

(1) 序 号	(2) 时间 $T(\mu s)$	(3) $N$ (位)	$B(\text{MHz})$	$TB$	$G = 10 \log_{10} N(\text{dB})$
1	6.4	32	10	64	15
2	12.8	64	10	128	18
3	51.2	256	10	512	24
4	102.4	512	10	1024	27
5	3.2	32	20	64	15
6	25.6	256	20	512	24
7	51.2	512	20	1024	27
8	25.6	512	40	1024	27

Key: (1) Sequence No. (2) Time (3) (Bit)

In This:  $T$ : SAW Convolvers Act on Zone Length.  $N$ : One Iteration of Correlation Code Length Carried Out within SAW Devices (or SAW Plug Delay Line Bit Number).

From Table 1, it is possible to obtain several important bits of knowledge.

1) The most important point is that processing gains grow proportionally as a function of  $TB$  values. However, they are certainly not equal to  $TB$ . Moreover, it is clearly shown that when lengths are  $T$ , processing gains are capable of reaching maximum corresponding values.

2) SAW convolvers act on zone lengths  $T$ , subject to limitations associated with technology and industrial processes. For example, in Table 1, as far as the 4th term is concerned, the necessity to create convolvers associated with  $T=102.4\mu s$  is very difficult. At the present time, using  $\text{Bi}_{12}\text{GeO}_{20}$  to act as convolver substrate, it is possible to make around  $T=50\mu s$ . Devices associated with quartz substrates are even more difficult to achieve.

3) When length  $T$  is fixed and code speeds go up, it is possible to make  $TB$  increase. However, this leads to increases in device band widths. Device band widths associated with various types of materials are limited. With regard to devices where different types of materials act as substrates, the relationships

between relative band widths ( $\Delta f/f_0$ ) relating to center frequencies and insertion losses (IL) are as follows [1].

(1)

In this,  $k^2$  is an electromechanical coupling coefficient associated with various types of materials (LiNbO<sub>3</sub> is  $k^2 = 4.5-5.7$ ; quartz is  $k^2 = 0.16-0.23$ ; Bi<sub>12</sub>GeO<sub>20</sub> is  $k^2 = 0.85-1.7$ ). The curve relationships are as shown in Fig.1. Under the same kinds of IL, relative band widths associated with Bi<sub>12</sub>GeO<sub>20</sub> and quartz are comparatively small.

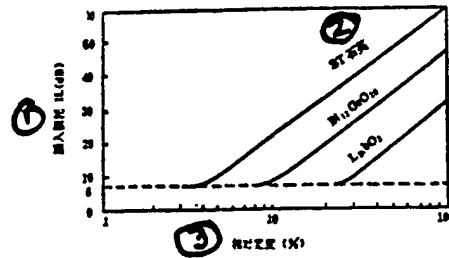

Fig.1 Relationships Between Relative Band Widths Associated with Various Types of Substrate Materials and Insertion Losses

Key: (1) Insertion Losses (2) Quartz (3) Relative Width

4) In order to increase relative band widths, it is possible to raise center frequencies. At the present time, center frequencies associated with SAW convolvers are generally only capable of being at several hundred MHz or less. Besides this, in systems, option is mostly made for center frequencies below 100MHz. Later in the article it will be seen that excessively high center frequencies--during time domain section processing--will bring with them even more stringent requirements with regard to certain parameters.

Summarizing what was described above, as far as TB values associated with single SAW devices are concerned, they are subject to constraints associated with such conditions as substrate material length, center frequencies, device insertion losses, as well as system center frequencies, and so on. The TB values will not be too high. As a result, processing gains achieved by devices themselves will not be too high.

Table 1 is parameters using SAW convolvers as an example. Speaking in terms of SAW plug delay lines, from technological levels at the present time, it is even more difficult to arrive at convolver TB values. The reason is that, as far as fixed plug delay lines are concerned, although they are capable of reaching a thousand bits or more, it is only possible to program plug delay lines--there are still no practical devices. After large scale

programmable devices are successful, their application methods will be simpler than convolvers. However, TB values associated with single devices are still finite. /10

### III. TIME DOMAIN SECTION PROCESSING METHODS

The basic principles associated with time domain section processing are as shown in Fig.2(a). Fig.2(b) is wave form diagrams for various points.

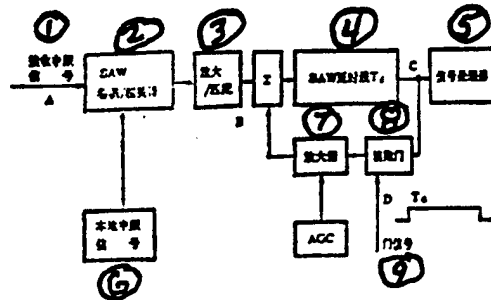

Fig.2(a) Time Domain Section Processing Line and Block Chart

Key: (1) (Illegible) Center Frequency Signal (2) SAW Convolver (3) Amplification/Matching (4) SAW Time Delay Line  $T_d$  (5) Signal Processor (6) (Illegible) Center Frequency Signal (7) Amplifier (8) (Illegible) Gate (9) Gate Signal



Fig.2(b) Wave Forms Associated with Various Points

Inputs are center frequency spread spectrum signals. They can be burst forms. They can also be continuous forms (Fig.2(b) Point A wave form). During burst forms,  $T_d$  is the period.  $T_s$  is the burst

section. When  $T_s = T_d$ , forms are then continuous. Correlation processors are composed of SAW convolvers. They are a type of programable matching filter. When input signals are long codes of up to a thousand bits, SAW matching filters process one signal section among them in each iteration.

As far as reference intermediate frequency signals produced by local signal generators are concerned--for various types of systems and different kinds of input signals--the formats of datum signals are also different. For specific designs, please see Reference [2].

Energy accumulation loops take correlation peaks, noise, and other useless signals following correlation processing and, in accumulation loops, recirculates accumulations. Following along with increases in the numbers of accumulation iterations, output signal to noise ratios achieve improvements. Delay line delays are  $T_d$ . This is equal to the interval distance between correlation peaks. With regard to amplifier compensation loop losses, amplifier gains are important parameters influencing performance. Elimination circuitry is to control numbers of accumulation iterations under the effects of control signals.

With respect to using AGC control circuitry in order to control changes in loop gain--with accumulation iteration numbers under 20-30--it is certainly not necessary to opt for its use [3]. In the performance analysis which follows, it will be possible to see this point.

#### IV. PERFORMANCE ANALYSIS

##### 1. Influences of Accumulation Loop Gains on Performance

Accumulation loop gain  $K$  has important influences on the performance of accumulators. Assuming that input signal amplitude is  $A$  and system band width is adequately broad, SAW convolver output signals--that is, correlation peaks--have output signal amplitudes after the  $M$ th iteration of recirculation coherence addition which are:

$$A_M = A + AK + AK^2 + AK^3 + \dots + AK^M = A \left( 1 + \sum_{i=1}^M K^i \right) \quad (2)$$

Assuming that accumulation loop input noise power is  $N$ , after going through  $M$  iterations of recirculation, output noise power is:

$$N_M = N + NK^2 + NK^4 + \dots + NK^{2M} = N \left( 1 + \sum_{i=1}^M K^{2i} \right) \quad (3)$$

Accumulator loop input signal to noise ratios are  $SNR_i = A^2/N$ . By contrast, output signal to noise ratios are:

$$SNR_o = A_M^2 / N_M = SNR_i \left(1 + \sum_{i=1}^M K^i\right)^2 / \left(1 + \sum_{i=1}^M K^{2i}\right) \quad (4)$$

From equation (4), it is seen that numerator growth is obviously faster than that associated with the denominator. This is nothing else than the basic cause for being able to improve output signal to noise ratios through accumulator loops. In that case, introduced (illegible) gains  $G_i$  which are achieved are:

$$G_i = 10 \log \left( \frac{SNR_o}{SNR_i} \right) = 10 \log \left[ \left(1 + \sum_{i=1}^M K^i\right)^2 / \left(1 + \sum_{i=1}^M K^{2i}\right) \right] \quad (5)$$

When gain conditions are ideal--that is,  $K=1$ ,

$$G_i = 10 \log(M+1) \quad (6)$$

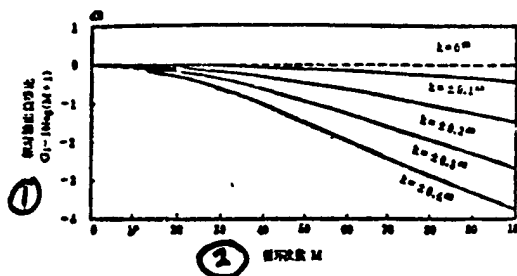

Fig.3 Relationships Between Output Signal to Noise Ratios and Coefficients K and M

Key: (1) Relative Output Signal to Noise Ratios (2) Recirculation (Illegible) Iteration Number M

For example, after recirculation accumulation iterations  $M=30$ ,  $G_i = 14.9\text{dB}$ . This is nothing else than to say that it is possible to make processing gains associated with entire spread spectrum systems increase 14.9dB (ideal theoretical value). This is then capable of very, very greatly improving deficiencies associated with small SAW convolver TB values. Capabilities associated with processing signals for entire systems very, very greatly strengthen. On the basis of equations (4) or (5), it is possible to obtain relationship curves for K, M, and relative SNR, as shown in Fig.3.

From Fig.3, it is seen that--compared to an ideal situation with  $K=0\text{dB}$  (that is,  $K=1$ )--when  $K=\pm 0.2\text{dB}$ ,  $M=20$ , and  $G_i$  drops 0.076dB. With  $M=60$ ,  $G_i$  drops 0.65dB. For  $M=100$ ,  $G_i$  drops 1.5dB. When  $K=\pm 0.3\text{dB}$ ,  $M=20$ , and  $G_i$  drops 0.173dB. With  $M=60$ ,  $G_i$  drops 1.28dB. For  $M=100$ ,  $G_i$  drops 2.17dB. From this, we see that tiny changes in loop gain will give rise to  $G_i$  losses. The larger M is, the more severe the influences.

However, from the analysis below, it will be possible to see

that it is certainly not the case that the larger M is the larger  $G_i$  then is. Moreover, after M reaches a fixed value,  $G_i$  basically does not change. The primary reasons limiting  $G_i$  increases are the influences of internal accumulation loop noise, delay line delay accuracies, as well as the fact that during the existence of slight phase shifts, multiple iterations of recirculation accumulate, and phase shifts also accumulate. In the end, coherence addition requirements cannot be met. Also, there are the influences of ambient temperature on delay lines and other devices, SAW delay line parasitic responses, and so on, and so forth.

## 2. Temperature Influences

Speaking in terms of time domain processing methods, temperature is also an important factor influencing performance. It will severely influence delay periods associated with SAW delay lines, making signals incapable of coherent addition--even to the point of becoming subtraction. Outputs are zero. Within loops, the higher intermediate frequencies are, the larger the influences are. In Fig.1, there are two types of SAW device. Speaking in terms of SAW convolvers, temperature changes basically do not influence performance. The primary reason is that reception signals and local signals move toward each other. Moreover, SAW delay lines are dual terminal devices. Temperatures will severely influence delay times. This then requires good temperature stability characteristics associated with delay line substrate materials. Delay line temperature coefficients are generally determined by the equation below [1].

$$\frac{1}{\tau} \frac{d\tau}{dT} = \alpha - \frac{1}{V_s} \frac{\sigma V_s}{\sigma T} \quad (7)$$

In this,  $\alpha$  is the coefficient of thermal expansion associated with materials.  $T$  is temperature.  $V$  is sound wave propagation speed.  $(1/V_s)(\sigma V_s/\sigma T)$  is the temperature coefficient associated with sound surface waves. /12

Delay line temperature coefficients are primarily determined by properties and propagation directions (that is, crystal cut directions) associated with substrate materials. Temperature coefficients for various types of materials are seen in Table 2.

Tests have been made with the systems in question associated with SAW delay lines. Center frequency was 70MHz. Code length was 255 bits. Option was made for the use of  $50\mu\text{s}$   $\text{Bi}_{12}\text{GeO}_{20}$  delay lines, at which time, due to the fact that correlation device output carrier frequency periods are 7ns, when temperatures change  $\pm 1^\circ\text{C}$ , delay line delay time periods will change 6.4ns. This is close to carrier frequency periods. As a result, it is not possible to maintain coherent additive characteristics in accumulation loops. Output signals are basically canceled out due to opposite phases. When option is made for the use of delay lines associated with  $25\mu\text{s}$  quartz crystal (ST, X) cutting, there are basically no temperature influences. However, it is certainly not the case that there are no influences at all. Besides this,

temperature still has certain influences with regard to other components in accumulation loops. After loops as a whole have been well adjusted, there are still comparatively small time errors. It is possible to use micro delay adjustments in order to regulate these. Here, the proposal to make use of  $25\mu\text{s}$  delay lines to replace  $50\mu\text{s}$  ones has conditions. It is necessary, in an iteration of correlation processing, to possess dual correlation peaks at which time is it only then possible to make the substitution. In this, there is simultaneously the explanation for a problem. As far as quartz crystals are concerned, although temperature coefficients are 0, achieving devices associated with large delays presents difficulties.

Table 2

① 基底材料及切割	② 瑞利速度(km/s)	③ 温度系数
LiNbO <sub>3</sub> (YZ)	3.48	$91 \times 10^{-6}/^{\circ}\text{C}$
④ 石英(ST,X)	3.15	0
Bi <sub>12</sub> GeO <sub>22</sub>	1.65	$128 \times 10^{-6}/^{\circ}\text{C}$
LiTaO <sub>3</sub> (YZ)	3.22	$37 \times 10^{-6}/^{\circ}\text{C}$

Key: (1) Substrate Materials and Cutting (2) Rayleigh Speed  
 (3) Temperature Coefficients (4) Quartz

### 3. Parasitic Signal Influences in Delay Lines

On SAW delay lines--besides signals passing through--there also exist parasitic responses associated with delay lines. Among these, mechanisms are comparatively complicated. Analyses are relatively difficult. Here, analyses are only made with regard to delay line tertiary responses and multiple mode transmission responses. Analyses associated with these two types of parasitic responses are already basically capable of reactions to the influences of parasitic signals on accumulation loop performance. The model associated with analyses is to take results for SAW delay lines acting as three types of delay line model and add them to each other--that is, three types of delay line model, where delay time is  $T_d$ , delay time is  $3T_d$  (that is, tertiary response), and delay time is  $\Delta T$ , are added together.

We assume that the main signal responses associated with delay times being  $T_d$  are impact and excitation functions associated with unit strengths. Parasitic responses associated with delay times being  $\Delta t$  are impact and excitation functions associated with  $\delta_0$ .

Tertiary transition 3Td parasitic responses are impact and excitation functions associated with intensities of  $\delta t$ .

Tertiary transition influences are one type of very special situation. After signals sent in go through tertiary delays, they still maintain a consistency with original signals. Strengths are simply weakened. It is possible to think of them as weakened original signals. Here, consideration is only given to tertiary transits. Moreover, such transitions as 5th iteration, 7th iteration, ..., and so on, are already very small. They can be ignored.

As far as multiple mode influences associated with delay times being  $\Delta t$  are concerned, it is assumed that  $\Delta t$  is very small values. Going through M iterations of accumulation, parasitic responses  $\Delta t$ ,  $2\Delta t$ , ...  $M\Delta t$  are formed. However, here, it is assumed that main signal band widths are larger than  $\Delta t^{-1}$ .

Assuming that the main inputted signal level is  $A_{in}$ , after going through delay line accumulation loops, the outputs should be the sum of the outputs associated with delays Td and 3Td. Then, on the basis of Formula (2), it is possible to obtain output signals associated with the Mth iteration of accumulation as:

$$A_M = A_{in} \left\{ \left[ 1 + \sum_{i=1}^M K^i \right] + \delta_i \left[ 1 + \sum_{i=1}^{M-3} K^i \right] \right\} \quad (8)$$

In this, when  $M < 1$ ,  $A_M = 0$ . For  $M < 3$ ,  $\delta_t = 0$ . When  $X < 0$ ,  $K^X = 0$ .

Parasitic signals are composed of three parts--main signals having gone through Td+ $\Delta t$  delay in association with the previous iteration of accumulation, parasitic signals going through Tc in the previous iteration, and tertiary transitions 3Td associated with parasitic signals. As a result, overall parasitic signals are the sum of three types of situation. Then, after M iterations of accumulation, parasitic signal SP is:

$$\begin{aligned} SP_M &= \delta_0 A_{in} \left[ 1 + \sum_{i=1}^{M-1} (i+1)k^i + Mk^M \right] + \delta_i \delta_0 A_{in} \left[ 1 + \sum_{i=1}^{M-3} (i+1)k^i + (M-3)k^{M-3} \right] \\ &= \delta_0 A_{in} \left\{ \left[ 1 + \sum_{i=1}^{M-1} (i+1)k^i + Mk^M \right] + \delta_i \left[ 1 + \sum_{i=1}^{M-3} (i+1)k^i + (M-3)k^{M-3} \right] \right\} \end{aligned} \quad \begin{array}{l} /13 \\ (9) \end{array}$$

In this, when  $M < 1$ ,  $SP = 0$ . For  $M < 3$ ,  $\delta_t = 0$ . When  $x < 0$ ,  $k^X = 0$ .

On the basis of equation (8) and (9), the ratio of signal and parasitic signal is:

$$\frac{A_M}{SP_M} = \frac{A_{in} \left\{ \left[ 1 + \sum_{i=1}^M k^i \right] + \delta_i \left[ 1 + \sum_{i=1}^{M-3} k^i \right] \right\}}{\delta_0 A_{in} \left\{ \left[ 1 + \sum_{i=1}^{M-1} k^i + Mk^M \right] + \delta_i \left[ 1 + \sum_{i=1}^{M-3} (i+1)k^i + (M-3)k^{M-3} \right] \right\}} \quad (10)$$

The ratio of relative signal and parasitic signal is:

$$\frac{\delta_o A_M}{SP_M} = \frac{\left[1 + \sum_{i=1}^M k^i\right] + \delta e \left[1 + \sum_{i=1}^{M-1} k^i\right]}{\left[1 + \sum_{i=1}^{M-1} (i+1)k^i + M k^M\right] + \delta e \left[1 + \sum_{i=1}^{M-1} (i+1)k^i + (M-3)k^{M-1}\right]} \quad (11)$$

Not considering tertiary transitions, when  $\delta_t=0$ , the ratio of relative signal and parasitic signal is:

$$\frac{\delta_o A_M}{SP_M} = \left[1 + \sum_{i=1}^M k^i\right] / \left[1 + \sum_{i=1}^{M-1} (i+1)k^i + M k^M\right] \quad (12)$$

From formulae (8) and (9), it is seen that accumulation signal  $A_M$  simply forms a direct proportion with input signals  $A_{in}$ . Moreover, parasitic signals and  $\delta_o$  form direct proportions with  $A_{in}$ .

When  $\delta_t=0$ , curves associated with relative signals and parasitic signals are as shown in Fig.4.

From Fig.4, it can be seen that, when  $\delta_t=0$ , the ideal gain  $k=0\text{dB}$ . After 50 iterations of accumulation, ratios of signals and parasitic signals drop 28.6dB. If the last system ratio of signal and parasitics is required to be maintained at 20dB, then, there is a need for SAW delay line suppression of parasitic signals to be 48.6dB.

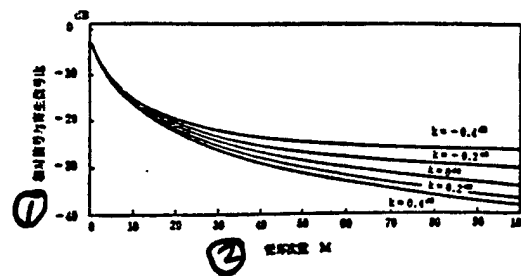

Fig.4 When  $\delta_t=0$ , Signal and Parasitic Ratio Curves

Key: (1) Ratio of Relative Signal and Parasitic Signal  
(2) Recirculation Iteration Number M

Below, consideration is given to when parasitic responses exist and analyses with regard to loop output noise. Their execution can be divided into two steps.

(1) Analyzing 3Td Tertiary Transition Response Influences. This type of situation is comparatively complicated. The tertiary transition influences which were pointed out above are a type of special case. Speaking in terms of signals, it can only produce signals that are the same as original signals but with reduced amplitudes. As a result, it is possible to see them acting as original signals. However, speaking in terms of noise, due to the random characteristics of noise--going through noise comparisons of noise and accumulated noise after tertiary transitions--there is a coherent portion, and there is also a noncoherent portion. Analyses are comparatively complicated. Moreover, Reference [4] has already demonstrated that, due to influences of tertiary transitions  $\delta_t$  associated with signal to noise ratios on Mth iteration accumulation outputs, the curves are simply translated in the direction of k reductions associated with curves in the ideal situation where k=0dB. Besides k values being reduced, output signal to noise ratios are also influenced. This article does not do further detailed calculations or analyses.

(2) Analyzing Td+Δt Parasitic Response Influences. Before analyses, assume that  $M\Delta t < T_d$ . This considers the worst case. Let  $N_{in}$  be input noise power. Then, output noise power associated with the Mth accumulation iteration is:

$$N_M = N_{in} \left[ 1 + \sum_{i=1}^{M-1} k^{2i} (1 + \delta_i^2)^i \right] (1 + \delta_M^2) \quad (13)$$

Based on formulae (1) and (13), it is possible to obtain relative signal to noise ratios as being: /14

$$\frac{s_M/s_{in}}{N_M/N_{in}} = \left( 1 + \sum_{i=1}^M k^i \right)^2 / \left\{ \left[ 1 + \sum_{i=1}^{M-1} k^{2i} (1 + \delta_i^2)^i \right] (1 + \delta_M^2) \right\} \quad (14)$$

Here,  $\delta_t = 0$ . When  $M < 1$ ,  $N_{in} = 0$ .  $S_M = 0$ .

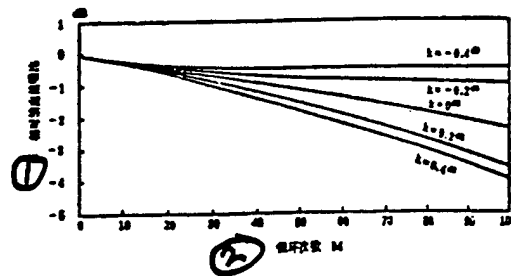

Fig.5 When  $\delta_0 = 0.1$ , Relationships Between M and Relative Output Signal to Noise Ratios

Key: (1) Relative Output Signal to Noise Ratios (2) Recirculation Iteration Number M

On the basis of calculations, and, in conjunction with that, from Fig.5, it is seen that, when  $\delta o=0.1$  (that is, when SAW delay lines possess 20dB suppression), for recirculation accumulations associated with  $M=20$  iterations, output signal to noise ratios are worse than under ideal conditions by 0.21dB. When  $M=50$ , this is 1.1dB. For  $M=100$ , it is greater than 2dB. When  $\delta o=0.01$ , SAW delay lines possess 40dB suppression capabilities. By contrast, after going through calculations, it is possible to know that signal to noise ratio deterioration is very small. One can ignore it in calculations.. The curves of Fig.5 explain requirements with regard to delay line multiple mode parasitic suppression capabilities.

#### 4. SAW Delay Line Band Width Influences

Correlation peaks enter into accumulation loops. Recirculation summation is carried out. SAW delay line operations are at double intermediate frequencies. Accumulation loop frequency response curves are different. After going through multiple iterations of accumulation, output signal to noise ratios are also different. For the sake of convenient calculations and analysis, square waves are used to replace input signals. Then, delta waves are produced at SAW matched filter output terminals. After that, they enter into accumulation loops. This is close to the actual situation. It is possible for this to act as a method of estimated calculation.

Assuming that SAW delay line frequency response is:

$$H(f)\exp(-j2\pi fT_d) \quad (15)$$

input pulse frequency is:

$$S(f) = \begin{cases} \tau \sin^2(\pi\tau f)/(\pi\tau f)^2 & |f| \leq 1/\tau \\ 0 & |f| > 1/\tau \end{cases} \quad (16)$$

In this,  $\tau$  is pulse width.

Power spectrum densities associated with white input noise after going through matched filters (that is, band pass filters) are:

$$N_o(f) = \begin{cases} \sin^2(\pi\tau f)/(\pi\tau f)^2 & |f| \leq 1/\tau \\ 0 & |f| > 1/\tau \end{cases} \quad (17)$$

Then, on the basis of the basic formula (2), it is possible to obtain output signals and noise after the Mth iteration of recirculation. It is assumed, at the same time, that only amplitude values are adopted in calculations--without considering the influences of phase. Besides this, as far as amplitude values are concerned, only maximum values when  $f=0$  are adopted. Loop amplification gains at this time are  $K$ . In that case, output signals after the Mth recirculation accumulation are:

$$A_M(f) = G(f) \cdot \exp(-jM 2 \alpha \pi f T_d) = \sum_{i=1}^M k^{i-1} H^i(f) \quad (18)$$

Output noise after the Mth iteration of recirculation accumulation is:

$$N(f) = N_0(f) k^{-3} \sum_{i=1}^M |k^i H^i(f)|^4 \quad (19)$$

In order to estimate calculations for SAW delay line frequency response, here, consideration is give to the several types of cases below, as shown in Fig.6.

$$H_1(f) = \sin^2(\alpha f / B_D) / (\alpha f / B_D)^2 \quad (20)$$

$$H_2(f) = \begin{cases} 1 & |f| \leq B_D/4 \\ \exp[-11.09(f/B_D - 0.25)^2] & |f| > B_D/4 \end{cases} \quad (21)$$

$$H_3(f) = \begin{cases} 1 - b + b \cos(8 \pi f / B_D) & |f| \leq B_D/4 \\ \exp[-11.09(f/B_D - 0.25)^2] & |f| > B_D/4 \end{cases} \quad (22)$$

In this,  $a=2.783$ .  $B_D$  is a 6dB band width.  $b$  is fluctuation with bands.

/15

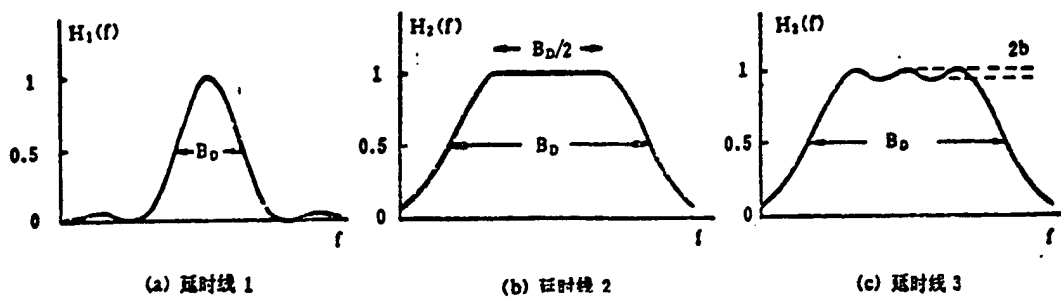

Fig.6 Several Types of Frequency Responses Associated with SAW Delay Lines (a) Delay Line 1 (b) Delay Line 2 (c) Delay Line 3

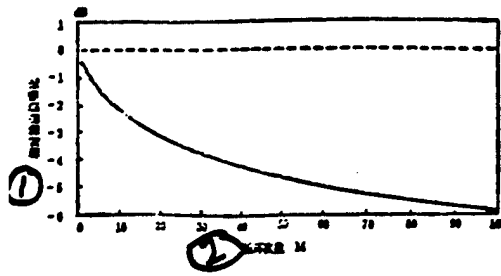

Fig.7 Relationship of M and S/N When Option Is Made for the Use of Delay Line 1

Key: (1) Relative Output Signal to Noise Ratios  
 (2) Recirculation Iteration Number M

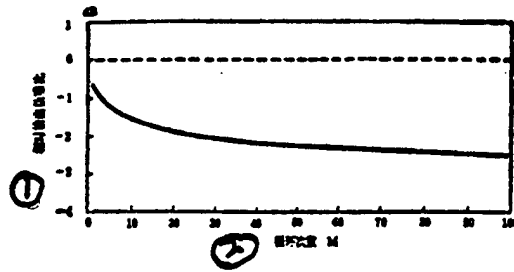

Fig.8 Relationship of M and S/N When Option Is Made for the Use of Delay Line 2

Key: (1) Relative Output Signal to Noise Ratios (2)  
 Recirculation Iteration Number M

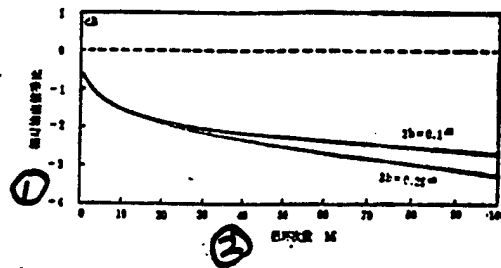

Fig.9 Relationship of M and S/N When Option Is Made for the Use of Delay Line 3

Key: (1) Relative Output Signal to Noise Ratios (2)  
 Recirculation Iteration Number M

On the basis of formulae (15)-(22), after going through calculations, it is possible to obtain the curves associated with Fig.7--Fig.9. They are the situations associated with output relative signal to noise ratio changes which follow along with increases in M when at various types of SAW delay line band widths. It is possible to see the following.

(1) Delay line band widths have definite influences with regard to output signal to noise ratios. The second type of wide band delay line is better than the first type of narrow band delay line. Output signal to noise ratios can achieve clear advantages. Following along with increases in recirculation iteration numbers, the advantages are more obvious still. When  $M=20$ , it is possible to achieve a gain of 1.4dB. When  $M=50$ , there is a gain of 2.3dB.

(2) Unevenness within delay line band widths will cause output signal to noise ratios to deteriorate. Following along with increases in M, deteriorations are even more severe. When fluctuations within band widths  $2b=0.25\text{dB}$ , the deteriorations compared to an ideally flat situation are as follows. For  $M=20$ , deteriorations are very small. For  $M=100$ , deterioration will be 0.7dB.

## V. ACTUAL EXAMPLES

Using an actual satellite system test as an example, explanation is made of the status of improvements in system processing gains. The primary parameters are as follows. Pseudo random code code length is 255 bits. Center frequency is 70MHz. Band width is 10MHz. System input signal to noise ratio is -17dB. The requirement for output correlation peak signal to noise ratios is  $\geq 3\text{dB}$ . The system in question opts for the use of  $50\mu\text{s}$  SAW convolvers and  $25\mu\text{s}$  long quartz crystals as substrate (ST, X) cut delay lines.

When accumulation loops are not added and input  $S/N=-17\text{dB}$ , output is 4.88dB (SAW correlation devices have approximately 1.52dB losses). After adding in accumulation loops, when recirculation iteration number  $M=5$  and  $k=0.6$ , output signal to noise ratios are measured as being 8.65dB. As far as processing gains of 3.77dB obtained by accumulation loops are concerned, they are 1.83dB smaller than theoretical values ( $G_{\text{(illegible)}}=5.6\text{dB}$ ). When  $M=5$  and  $k=0.8$ , output signal to noise ratios are measured as being 10.08dB--achieving a gain of 5.2dB. This is around 2dB smaller than the theoretical value of 7.2dB. To say it another way, it is equivalent--when indices require that signal to noise ratios be 3dB--to being able to process signals associated with input signal to noise ratios of -24.68dB. The reasons that loop processing gains are lower than theoretical values are multifaceted. Primarily, they are the results of comprehensive influences such as measurement errors, phase accuracy in accumulation loops, noise within loops, as well as device quality, and so on.

With regard to increases in recirculation iteration numbers,

it is possible to obtain even larger loop processing gains. However, with respect to SAW convolvers, performance of delay lines as well as different circuitry inside systems will be associated with even more stringent requirements. Moreover, extremely careful adjustments must be made with regard to various parts of circuits.

## VI. CONCLUDING REMARKS

Through the theoretical analysis above, calculations, and actual examples, it is possible to see that "large time band width product processing methods" possess very important practical value and real significance. In systems where input signal to noise ratios are extremely low, they are very useful--for example, they can be used in such areas as satellite systems as well as fast acquisition spread spectrum technologies with extremely low signal to noise ratios, and so on.

Fig.'s 3-5 and Fig.'s 7-9 are sets of curves that possess practical usefulness. After stipulating delay line performance parameters, it is possible through curves to make estimated calculations of maximum output signal to noise ratios which can be obtained. Conversely, through curves, it is possible to know--when it is necessary to obtain maximum output signal to noise ratios to the greatest extent possible--what indices SAW delay line performance should reach.

System tests are the results of the efforts of the entire spread spectrum project team. We express our gratitude for this.

## REFERENCES

- [1] 武以立等, 声表面波原理及其在电子技术中的应用, 国防工业出版社, 1983.
- [2] 许宗泽, 同步的快速捕获, 1986年南航学报第一期, 1987年全国扩频会议.
- [3] D. P. Morgan and J. M. Hannah, Correlation of Long Spread-Spectrum Using a SAW Convolver/Recirculation Loop Sub-System, IEEE. 1976, Ultrasonics Symposium Proceeding. p. 436.
- [4] D. P. Morgan and J. M. Hannah, Correlation of Long Sequences Using a SAW Convolver and Recirculation Loop. IEEE. 1975, Ultrasonics Symposium Proceeding. p. 189.

CHINESE ELECTRONIC COMMUNICATIONS PRODUCT, MANUFACTURING  
EQUIPMENT, AND TECHNOLOGY EXCHANGE EXPOSITION NEWS

Translation of "Zhong Guo Guo Ji Dian Zi Tong Xin Chan Pin, Zhi Zao She Bei He Ji Shu Jiao Liu Zhan Lan Hui Xiao Xi"; Journal of China Institute of Communications, Vol.13, No.1, January 1992, p 16

The Chinese electronic communication product, manufacturing equipment, and technology exchange exposition (CIETE'92) is set to be hosted in the Shanghai exposition center from 21-24 April 1992.

The exposition in question is jointly sponsored by the China Electronics Society, the China Communications Society, the Shanghai Yangtze Communications Equipment Group, the Shanghai External Science and Technology Exchange Center, the Huazhan International Exposition Company, and World Expositions Ltd. In conjunction with this, support has been obtained from relevant departments. Such responsible leading comrades as the Minister for Posts and Telecommunications, Yang Taifang, the Minister for Aviation and Astronautical Industry, Lin Zongtang, the Deputy Minister for the Electrical Machinery Industry, Zeng Peiyan, the chief of the State Council's office for the expansion of electronic information systems applications, Zhang Wuqiu, as well as the China Electronics Society Director, Sun Junren, the China Communications Society Director, Li Yukui, and so on, have respectively written words of encouragement for the exposition.

The exposition will provide broad exchange of technology for domestic and foreign firms as well as numerous scientific and technical workers, opening up channels for cooperation in the conduct of trade as well as information and markets associated with the selection and purchasing of domestic and foreign advanced technological products.

The range of participation in the exposition includes communications equipment, digital program control switching equipment, digital microwave communications equipment, fiber optic communications equipment, satellite communications equipment, PCM equipment, mobile communications equipment, wireless communications equipment, various types of communications terminal equipment, radar and radio navigation equipment, electronic computers and their peripheral equipment, office automation equipment, electronic component, device, and manufacturing equipment, microelectronics technology and materials, television broadcast equipment, instruments and gauges, household electronics, electric appliances, standard metrological devices and measuring tools, weighing apparatuses, security equipment, as well as other electronic products.

As far as relevant items for participation in the exhibition are concerned, contact can be made with Comrade Zhou Shunzhi. The communications address is (200020) Shanghai, Maomingnanlu No.58, Jinjiang Club, Building No.3, Room 58646, Chinese International Electronic Communications Product Manufacturing Equipment Exhibition Office, Tel: 2152924, FAX: 021-2153754.