

AECD - 1865

UNITED STATES ATOMIC ENERGY COMMISSION

SUMMARY REPORT ON THE DEVELOPMENT OF ELECTROMETER RADIATION INSTRUMENTS

by

O. G. Landsverk
E. O. Wollan

Argonne National Laboratory

DEPARTMENT OF COMMERCE
Approved for public release
Distribution Unlimited

Date of Manuscript: July 25, 1944
Date Declassified: April 13, 1948

Issuance of this document does not constitute authority for declassification of classified copies of the same or similar content and title and by the same author.

Technical Information Branch, Oak Ridge, Tennessee
AEC, Oak Ridge, Tenn., 2-2-49--850-A3704

Printed in U.S.A.
PRICE 10 CENTS

RECEIVED AT
LIBRARY OF CONGRESS
MAY 19 1948

MAY 6 1948
MAY 5 1948

LIBRARY OF CONGRESS
DIVISION OF CONGRESS
TO BE RETURNED

Copy # 40

03951

19970128 267

06884
06884

SUMMARY REPORT ON THE DEVELOPMENT OF ELECTROMETER RADIATION INSTRUMENTS

By O. G. Landsverk and E. O. Wollan

INTRODUCTION

About eight months ago work was started on the development of a quartz fiber electrometer for use in portable radiation measuring equipment. The following is a report on the characteristics and method of construction of the electrometer and on the various types of instruments which have been built around this electrometer unit. The report is divided as follows:

- A. Construction Techniques of the Electrometer
- B. Properties of the Electrometer
- C. Types of Instruments
 - 1) Gamma-Beta Ray Survey Meter
 - 2) Small Gamma Ray Survey Meter
 - 3) Pocket Electrometer Dosimeter
 - 4) Fast Neutron-Gamma Ray Survey Meter
 - 5) Alpha Ray Meter
 - 6) Direct Reading Gamma Ray Survey Meter
 - 7) Laboratory Type Gamma Ray Meter
 - 8) Air Tight Pocket Chamber and Projection Type Electrometer Unit

A. CONSTRUCTION TECHNIQUES OF THE ELECTROMETER

The process of making the electrometers divides naturally into three phases:

- 1) Blowing the fiber
- 2) Making the electrometer proper
- 3) Putting a conducting coat on the fiber

On the first topic there is little new to offer. Fiber making is an art in which skill and practice will help to increase the percentage of fibers of useful dimensions. Quartz rods of 1/16-inch diameter are suitable for starting material. The oxygen flame from a torch with a one to two millimeter opening should be about one foot high, extending vertically upward, should be about 3/8 inch in diameter, and should have an inner cone at the torch tip about 1/4-inch long. A ball of melted quartz is formed between two pieces of quartz rod. When it is white hot this is removed from the flame and quickly drawn into a rod 1/2 to 1/10 mm in diameter and one to two feet long. A 4- to 6-inch length is cut off,

the 1/16-inch rod serving as a handle. The finer rod is then "floated" in the side of the flame. Just as the upper end of the rod shoots up out of the flame the lower end must be quickly removed from the flame or the fiber will be lost. A fiber that is several feet in length may at times be produced and used. Such fibers are the most uniform in diameter and the least curved. The fibers are laid on a black velvet cloth. The cloth is mounted on a stiff cardboard to eliminate wrinkles. A strong fluorescent lamp or one or two table lamps with 100 watt bulbs are placed so the fibers are visible by reflection.

No reliable method is known for predicting by inspection, except very roughly, the diameters of fibers. Sections of the fiber must be mounted with beeswax on wire stirrups of appropriate length (No. 30 brass wire is suitable) and the diameter of the wire measured in a microscope. This should have a magnifying power of 400 diameters or over and should be fitted with a micrometer eyepiece. A convenient electrically heated wire loop mounted on a handle for fastening the fibers on the stirrups is easily designed and constructed.

The electrometer fiber support rod is a 30 mil phosphor bronze wire which is squeezed flat in a vise at one end. A 1/8-inch long by 3/16-inch diameter polystyrene insulator is clamped with a set screw in a 3/16-inch hole through a 1/4-inch thick brass block. The hole is covered at one end with a thin brass sheet to protect the insulator from the heat of a small gas flame. A hole large enough to accommodate the flattened end of the rod is drilled through the sheet and through a suitably placed brass strip so as to guide the rod along the axis of the polystyrene insulator. When a small gas flame is applied to the rod near the insulator, the rod will melt its way through. Just as the rod comes through, it is quickly thrust forward into position and the flame removed. The polystyrene sets almost instantly and has a very secure grip on the flattened portion of the rod. A suitable length of the projecting rod is carefully cleaned of a film of polystyrene which adheres to it. It will serve as contact arm for the charging rod.

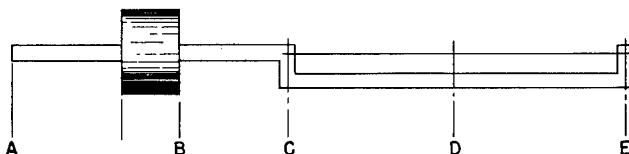

Figure 1. Steps in the construction of the electrometer.

The subsequent steps in the construction of the electrometer are indicated in Figure 1. The flattened portion of the rod extends from A to B. The segments at C and E are about 1 1/2 mm in length. The fiber is fastened to these segments as shown. The fibers, still on the brass stirrups, are maneuvered into position. Then a small drop of Zapon or Aquadag is deposited at the points of contact of the fiber and support rod. The cement dries and hardens quickly. If the deposit seems too thin a second application may be made. The fiber is then cut free from the stirrup with dissecting scissors. Distance BC is made of such a length that, for the chosen length of fiber CE, BD is 1 1/2 mm longer than the distance from the insulator clamp of the electrometer to the microscope axis. When the fiber has been mounted, segment DE is bent so it is perpendicular to CD and to the plane of the paper. D is the midpoint of CE. The fiber is now bent at right angles at its midpoint so it runs parallel to the support rod along its entire length. This is accomplished by stretching the fiber over a 5 to 10 cm long quartz rod of about 1/2 mm diameter and heating with a very small flame. The process has many pitfalls and can be discussed only briefly.

A manipulator is essential. This can be designed and built by anyone who has the requirements in mind. It holds the electrometer so segments CD and DE have a position like that of two opposing rafters in a roof. It also holds the quartz rod in a direction that is parallel to the ridge of the roof.

The rod approaches from the fiber side of the electrometer and has a screw controlled vertical motion. The fiber is caught at its midpoint and tightened across the rod. The fiber is gently blown clear of the electrometer support rod before being pulled taut so the small flame can reach it. Too much tightening breaks the fiber, too little makes a good bend impossible. A black plush cloth under the manipulator for background, a strong light and a magnifying glass of 5 to 10 power are essential.

The microtorch for bending the fibers is a simple affair which has served very well. It consists of a 1/4-inch outside diameter copper tube which passes through a wooden or similar handle. The gas hose is connected to the end of this tube which projects at the base of the handle. Soldered into the tube at the other end of the handle is a 1/16-inch inside diameter copper tube. This projects about 3 inches and is bent into a convenient curve. The nozzle is made by filling the end of the tube with solder and pulling out a 0.005-inch wire just as the solder sets. If the gas pressure is kept low a globe of flame about 1/8-inch in diameter can be had. This is right for fibers of 5 to 8 microns. A reduced size will do for 3 to 5 micron fibers. The flame temperature varies strongly with its size. Proper choice of flame size will greatly reduce fiber breakage.

In the bending process only a dim light barely sufficient to permit the fiber to be seen is used. This will permit the temperature of the fiber to be judged by the faint glow from fine particles of dust which may adhere to the fiber. Large particles of dust ruin the fiber by making it impossible to bend it without breakage. In the absence of dust particles, one must judge the temperature of the fiber on the basis of size of the flame and its position and check at intervals until a proper bend has been made. Here it is a great convenience to keep the flame size down so the fiber is not readily melted, but will barely soften and bend. The sharpest possible bend has, of course, a radius of curvature equal to the radius of the quartz rod. Too prolonged heating at the bend will fuse the fiber on the rod. A thick support rod is better than a fine one in this respect.

If the segments of the fiber are not straight after bending the electrometer can frequently be salvaged by passing the flame slowly along the portions that are curved while the fiber is still under tension. If the fiber comes too close to the support rod at the bend, it can be pulled away from the support rod with a screw movement which pulls the quartz rod back (or simply be blown a sufficient distance out on the rod before tightening). Heating the fiber near its ends will then frequently cause it to assume the proper position.

A viewing chamber that is free from air currents is convenient for examining the finished electrometer. The electrometer is mounted by sliding the insulator into a 3/16-inch hole which is drilled vertically to a suitable depth in a metal block. A brass tube of suitable size is placed around it. The tube is covered with a glass plate. The electrometer is examined with a magnifying glass through the glass cover. Strong illumination is necessary.

The problem of placing a satisfactory conducting coat on the fiber has given some trouble. In sputtering, the electric field is strong and the fibers may be pulled up under their support rods. If this field and its effects are reduced by having the anode far from the cathode in the sputtering jar, the coating is found on only one side of the fiber and its thin edges are not sufficiently conducting. The result is a fiber that creeps up to its equilibrium position when it is charged. This is particularly bad in survey meters. (Evaporation with gold has not given durable coatings. Trouble was also experienced here in getting thin coatings that covered the entire fiber. This method was not thoroughly explored, however.) The remedy lies, of course, in a uniform and sufficiently thick coating. Two methods were used. One can place the electrometer inside of a platinum ring near its axis. This gives a uniform coating if the fiber does not become tangled with the support rod. A second method is to sputter the electrometer twice—once from each side. The electrometers may then be a considerable distance from the cathode.

The fibers may be kept free of the support rods in one of three ways, or a combination of them: (1) The electrometers and their mounting block may be set on a metal stand and surrounded with a faraday cage. This assembly then serves as the anode and is grounded. The cage is surrounded by

the sputtering ring. The platinum atoms pass through the cage much as electrons through the grid of a radio tube. This eliminates the electric field at the fibers, but does not prevent the platinum ions from charging the fiber and causing the support rod to attract it. (2) A fine wire may be placed between the support rod and the fiber so as to hold the fiber away from the rod. The fine wire is soldered into the block on which the electrometers are mounted in sputtering and is bent into place while the fiber is blown out of reach. This method may leave an unsputtered spot at the point of contact of the fiber and the stirrup but no bad effect has been traced to this source. (3) The sputtering current may be reduced to 5 ma or less. This reduces both the electric field and the charging effect of the platinum ion stream.

Method (2) combined with a considerable distance between the cathode and the fibers and double sputtering (once on each side) was usually found to be most satisfactory.

B. PROPERTIES OF THE ELECTROMETER

Since the electrometer is the fundamental unit around which the various types of instruments are built, it is felt that a rather complete report on its characteristics and structural details is desirable.

The electrometer fibers vary, according to their intended use, from three to ten microns in diameter (usually from four to six microns) and seven to thirty mm in length on each side of the L shape into which they are bent. The arms of the L are equal in length. As stated in Section A, both ends of the fiber are fastened to right angle bends on the L shaped phosphor bronze support rod. The fiber is then parallel to its support rod along its entire length and one half to one and a half mm from it. This distance affects overall sensitivity and so is made small when high sensitivity is desired. The fiber is viewed with a fifty to one hundred fifty power microscope at a point which is about one mm from its bend.

A grounded rod is placed so that the fiber swings between it and its support rod when voltage is applied. Since the ground rod is placed outside the arc of the fiber, the fiber cannot become attached to it. The ground rod is close to the support rod at the base of the fiber and swings away from it at the bend (one to five mm at the base, two to twenty-five mm at the knee. The distances vary with the application).

In spite of an obvious increase in the capacity of the system due to the ground rod, the sensitivity of the electrometer may be more than doubled by this means. This is so because the electric field is increased in the region around the fiber. A further advantage of this system is that the scale may be made linear within quite close limits. This effect will be discussed below.

Many types of electrometer holders have been designed for various applications. A sketch of the type used in the gamma-beta ray survey meter is shown in Figure 8A, part C. It is seen that the entire system may be rotated about the microscope axis AA'. It is possible in this way to make the fiber perpendicular to the scale in the microscope eyepiece. Rotation is also provided about axis BB'. This permits the fiber to be set to zero on the scale for any desired voltage. Finally, it is possible to rotate the electrometer and its clamp about axis CC' so that the fiber is caused to be in focus along the entire scale. The condition that must be fulfilled here is that the axis of the microscope must coincide with the radius of the fiber path when the fiber is at the center of the scale. The objective lens holder is threaded so that the objective lens may be moved along the axis of the microscope for fine adjustment of the focus. Correct adjustment is complicated, unfortunately, by the fact that some of the aforementioned motions are not independent.

This electrometer as it has been adapted in various radiation meters has shown itself to have a number of advantages over comparable meters. Some of these will be listed below:

- 1) Since the fiber is fastened at both ends, it is mechanically more stable and robust.

2) In normal use, the fiber will not become attached to its support rod or to the ground rod. If, for any reason, it does so, it may be freed with negligible danger of breakage. Simply disconnecting the voltage by depressing the charging button (on instruments so equipped) will frequently free the fiber. If not, a gentle puff of air from the appropriate direction is all that is required.

3) In most applications (pocket size rate and dose meters are exceptions), the full voltage is on the fiber at all times except when a reading is taken. The fiber is therefore in complete mechanical and electrical equilibrium at the start of every reading. This is not true for many fibers (probably not entirely for any) if they are charged immediately prior to use. The reason may be absorption of charge by the insulator or more generally a poorly conducting fiber coating. Errors equivalent to a change of three volts have been observed in some commercially available meters due to this cause.

4) The use of a ground rod permits the attainment of higher sensitivity with no sacrifice in stability. In portable meters, a voltage sensitivity of five divisions per volt is readily obtained and a current sensitivity of full scale in one hundred seconds for gamma radiation of $12\frac{1}{2}$ mr/hr. ($12\frac{1}{2}$ mr/hr is accepted as the tolerance rate for an eight hour period each day). This result is obtained with a fiber that is ten mm long and four and a half microns in diameter with one hundred thirty-five volts of fiber potential and an ionization chamber of two hundred cu cm volume.

5) If desired, the scale can be made linear within quite close limits. To accomplish this, the ground rod is moved towards the support rod but out of reach of the fiber. When the ground rod is close to the fiber at maximum voltage but out of line with it, sensitivity is lower because the geometry is unfavorable. The strong attraction of the ground rod has only a small component in the direction of motion of the fiber. On the other hand, when the voltage is lowered, sensitivity will again eventually drop because the electrostatic forces on the fiber are smaller. Somewhere between these positions is a region of maximum sensitivity. In the neighborhood of this maximum, the sensitivity is nearly uniform over the entire scale. One added fact may be of interest. When the sensitivity is made uniform over the entire scale, as described above, the sensitivity is about two-thirds of the maximum (top of scale) sensitivity that can be had with the same fiber and voltage.

C. TYPES OF INSTRUMENTS

A number of types of instruments for measuring radiation have been designed with this electrometer as a basic unit. They will be described briefly in what follows.

1. The Gamma-Beta Ray Survey Meter

Many improvements have been made on this meter since it was described in a previous report (CP-1158). These include details for easier adjustment and assembly, more rugged and trouble-free construction, longer life of batteries, a linear scale when desired and a double range.

The meter is contained in a $3\frac{1}{4}$ by 6 by $5\frac{1}{4}$ -inch high metal case. (See photographs, Figures 2 and 3). The electrometer assembly is clamped directly to the microscope tube inside the aquadag coated bakelite chamber. A $1\frac{3}{4}$ by 3-inch aluminum window at the front of the chamber permits the measurement of beta rays (see Figure 4 for details).

The push button switches that operate the microscope light and the fiber charging contact are so modified that they may be locked in the depressed position by a slight clockwise rotation of the push button. This permits one conveniently to use the meter with a stop watch for accurate laboratory measurements and similar applications.

Since the circuit is similar in all the meters except the pocket models, it is reproduced here as representative of all types (Figure 5).

The time relaxation circuit type of timer permits measurements of rates from 100 to 200 mr/hr in the first range, depending on the scale that is used. The time constant for this range varies from

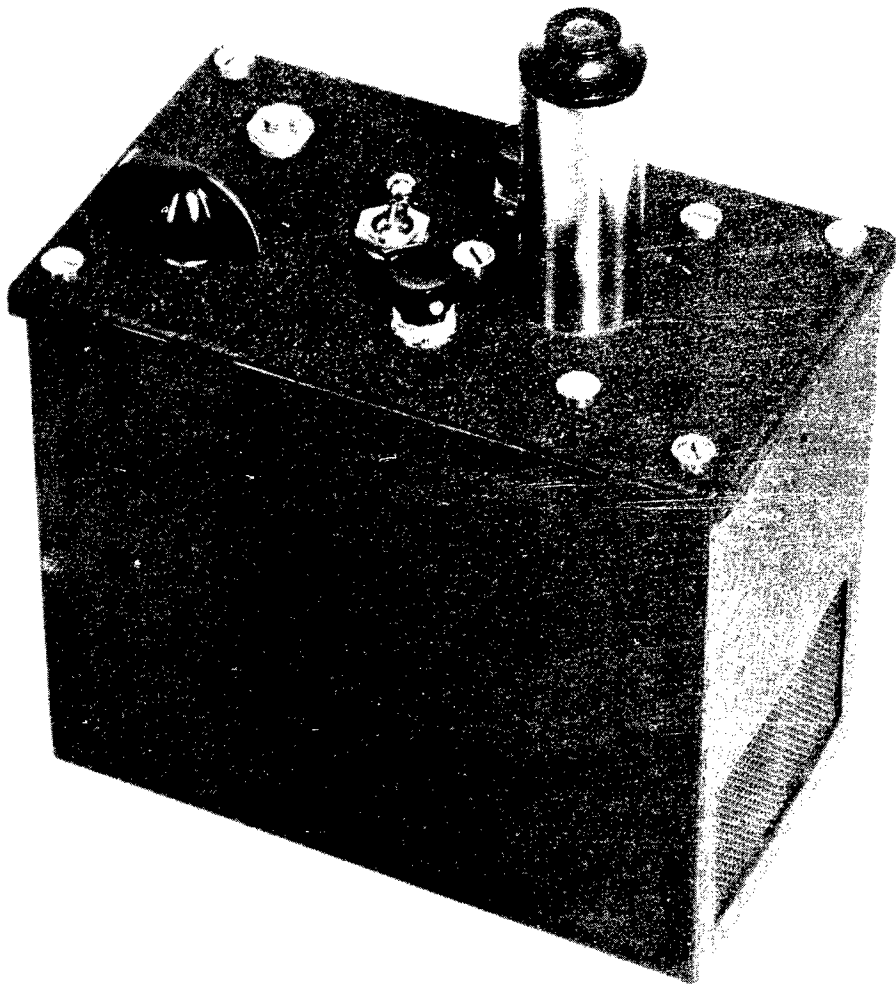

Figure 2.

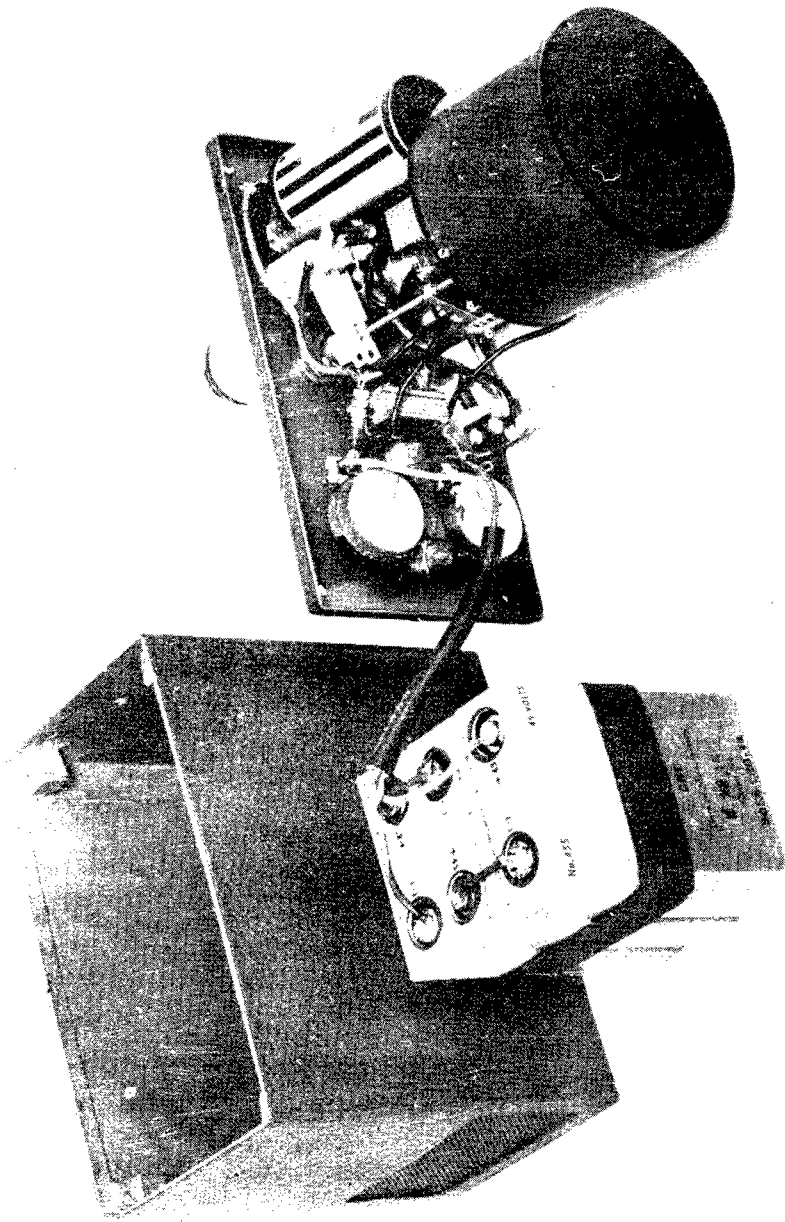

Figure 3.

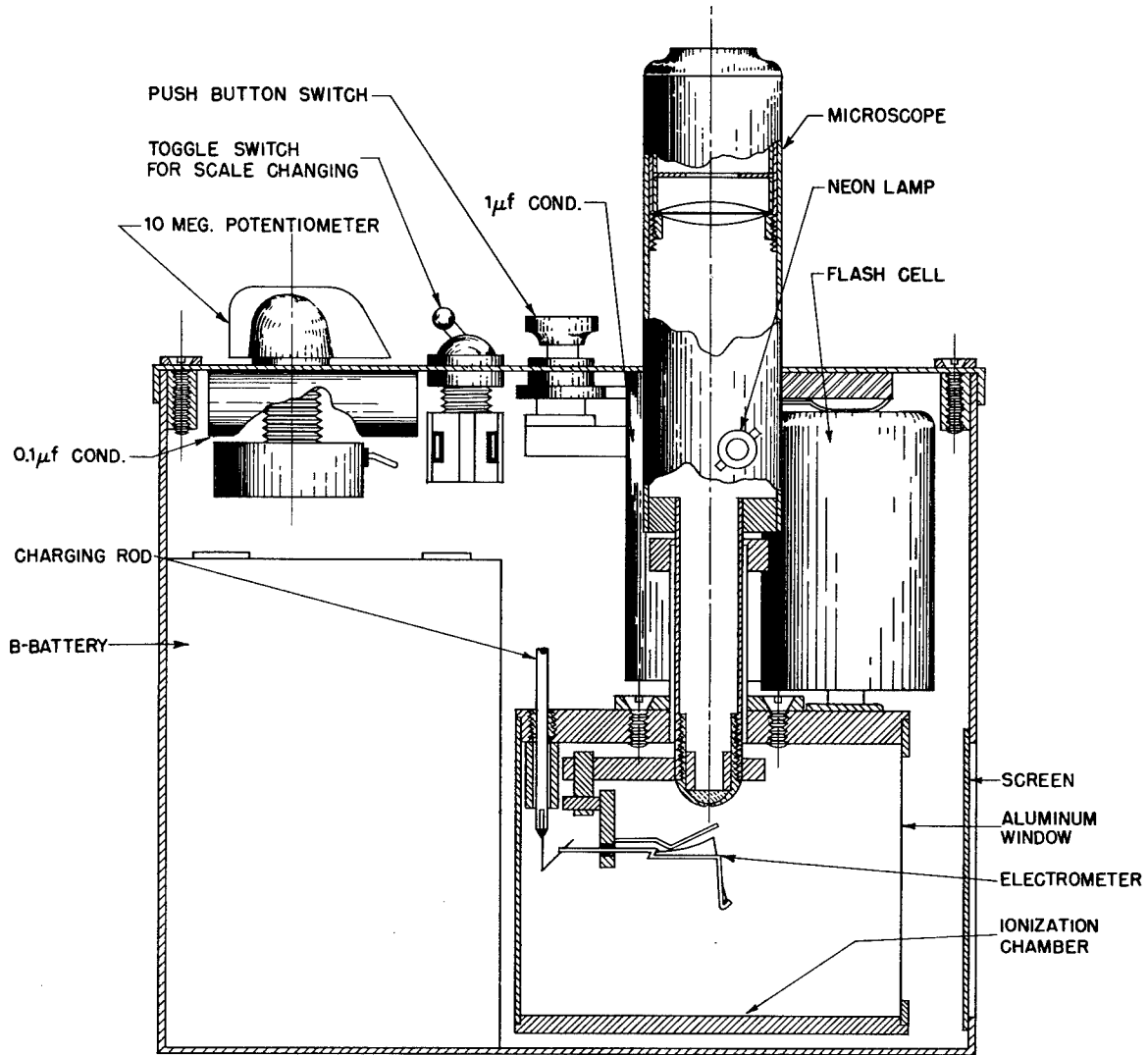

Figure 4.

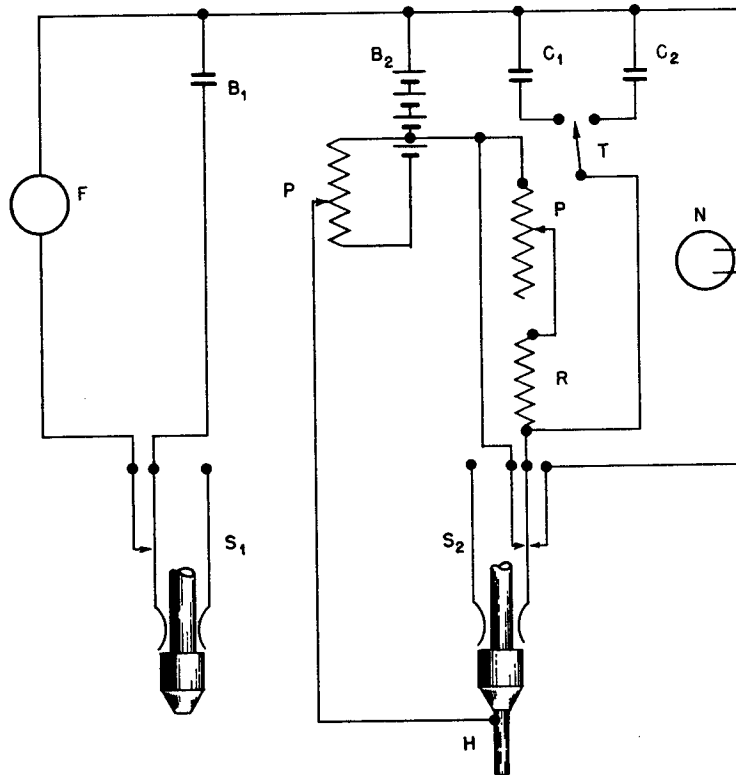

Figure 5. Gamma-beta ray survey meter circuit.

- B₁ - Two No. 2 cells in parallel
- B₂ - Three 45 v minimax
- C₁ and C₂ - 1.0 and 0.1 μ f condenser
- F - Two cell self-focusing bulb
- H - To electrometer contact
- N - 1/4 watt neon bulb
- P - Potentiometers, 10 megohms
- R - 10 to 30 megohms
- S₁ and S₂ - Push button switches
- T - Toggle switch

six to fourteen seconds. A second range which uses the same scale is available by throwing a toggle switch. The time constant is then cut to one-tenth of the low scale interval, and all scale readings are multiplied by ten. A typical calibration of one of these meters is tabulated below. The time constant is adjusted to give the correct reading at the usual $12\frac{1}{2}$ mr/hr. The calibration was done by S. Crain with the special equipment that the Health Physics Group has available for this purpose.

It is seen that: (a) the low reading scale never departs from the true value by more than five per cent; (b) Up to 1.0 r/hr the high reading scale has an error which does not exceed seven per cent, is 20% at 2.0 r/hr; (c) the high reading scale with its convenient 1 to 2 second time constant can be used with 10% accuracy down to 25 mr/hr.

This easily operated double range timer system is therefore seen to give readings that are sufficiently accurate for survey work without the use of stop watches, correction factors, or calibration charts.

Actual rate (mr/hr)	Low scale reading	Error (%)	High scale reading	Error (%)
2400			2000	-20
1040			1100	+6
665			700	+5
205	200	-3	220	+7
166	168	+1	170	+2
115	118	+3	120	+4
74	77	+4	75	+1
41.5	43	+3	40	-3
26.6	27	+2	25	-6
18.4	19	+3	15	-27
13.6	13	-5	10	-36
10.4	10	-4	-	-

At 665 mr/hr, which is the maximum rate for which calibrations are available from the Health Physics Group, six Lauritsen electroscopes chosen at random show an average error of -71 per cent. The errors range from -45 to -121%. The three L. and W. Electroscopes made with the double range show errors for the same radiation of -5.0, +5.7, and -6.3 per cent.

The meters have a sensitivity of about 20 volts for full scale when operated at 135 volts. With a 200 cc chamber and a radiation rate of $12\frac{1}{2}$ mr/hr (current in chamber about 2×10^{-13} amp) the fiber moves full scale in about 100 seconds.

2. Small Gamma Ray Survey Meter

This meter is near the ultimate so far as size is concerned for a meter which is battery equipped both for fiber potential and microscope light. See Figure 6 for details of construction. It is mounted in a case of dimensions 1 by $3\frac{1}{2}$ by 6 inches. The case has no projections except a small push button for the light switch and the microscope eyepiece shield. The fiber potential is furnished by one 45 v hearing aid battery. Battery drain is negligible, so battery life should be equal to shelf life. Charging is done by tilting the instrument forward so the gravity operated charging stirrup makes contact with the electrometer. Contact is broken when the instrument is vertical or tilts backward. The single No. 1 flashlight cell for the microscope light is easily replaceable.

The design permits the sealing of all parts except the flash cell compartment against moisture.

Although the fiber potential is only 45 volts and the ionization chamber has a volume of only 75 cc, the instrument gives a deflection of one-tenth full scale in twenty seconds for $12\frac{1}{2}$ mr/hr.

3. The Pocket Electrometer Dosimeter

This instrument is intended for use of persons on special jobs who require to know while at work the total radiation to which they have been exposed. It consists of a variation of the L. and W. electrometer which is mounted at the end of a small microscope. The case is an aluminum tube $\frac{5}{8}$ inch in diameter and 6 inches long. Figure 7 shows the details of construction.

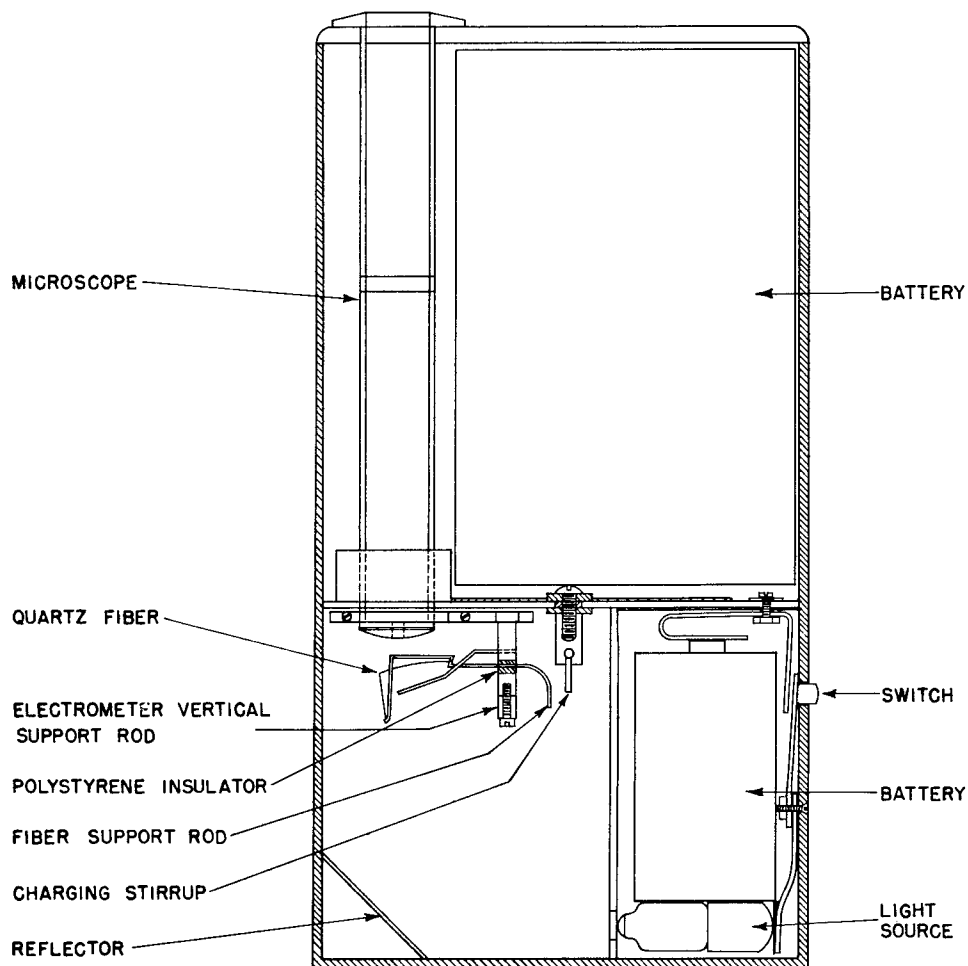

Figure 6. Details of construction of the small gamma ray survey meter.

The full scale dose reading can readily be adjusted without redesigning the instrument within a range of values from perhaps 0.05 r to about 1.0 r. This value is adjusted readily by making the electrometer more sensitive and decreasing its capacity and vice versa to approach the lower and the upper limits of the range respectively. Present models have a full scale reading of about 0.3 r. Their calibrations are fastened to the barrel of the meter.

The meter can be read at any time by pointing it at a source of light. A separate charging box is, however, required. This consists of a small battery box on the cover of which is mounted a charging socket, a potentiometer, and a toggle switch. Figure 8b is a section drawing of the upper portion of the charging box. Figure 9 shows the appearance of the meters and the charging box. To charge, the cap is removed from the electrometer end of the meter and it is inserted into the charging socket. The toggle switch is thrown on and the potentiometer adjusted so that the fiber will be at zero of the scale when the meter is removed from the charger and the cap is replaced.

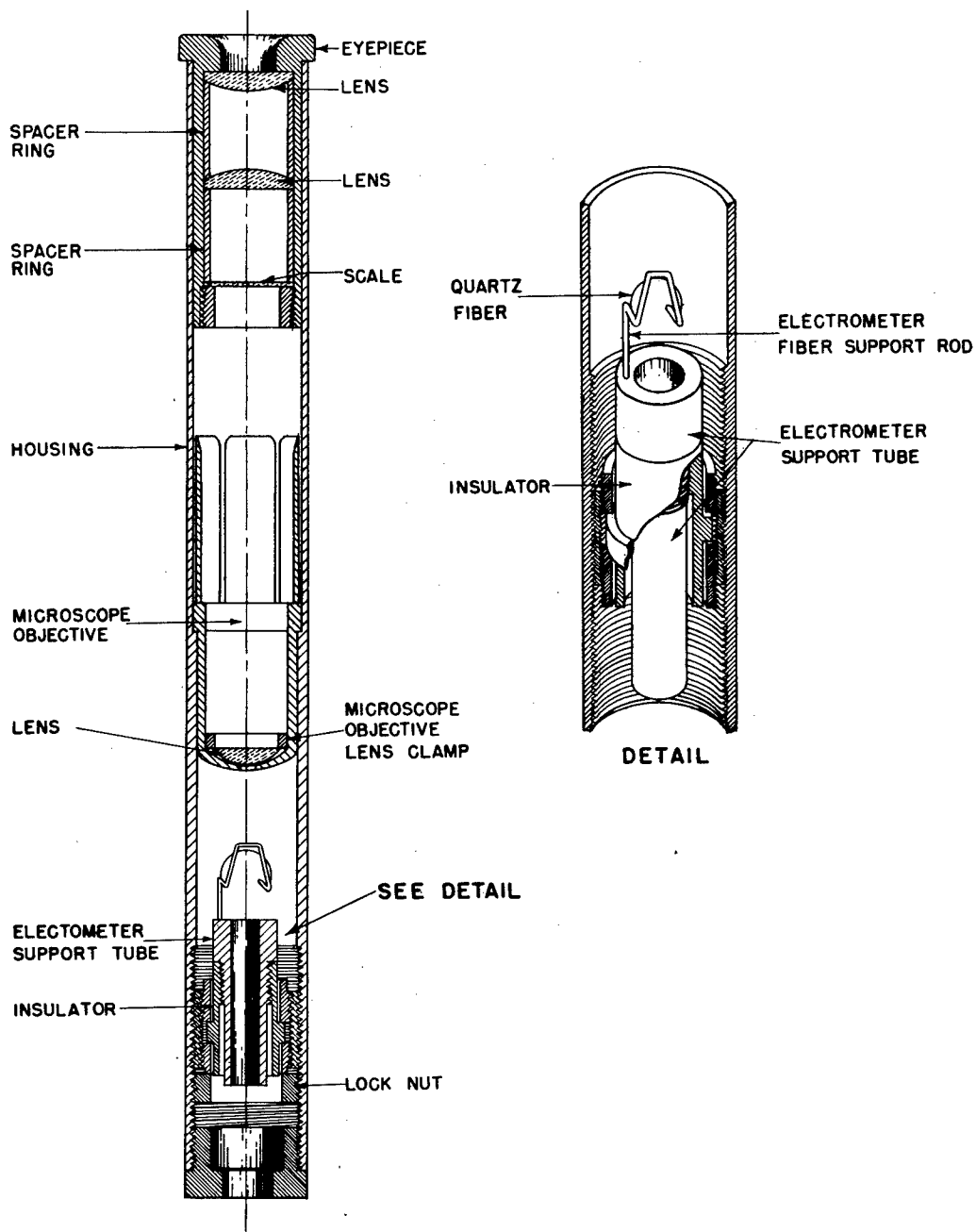

Figure 7. Details of construction of the pocket electrometer dosimeter.

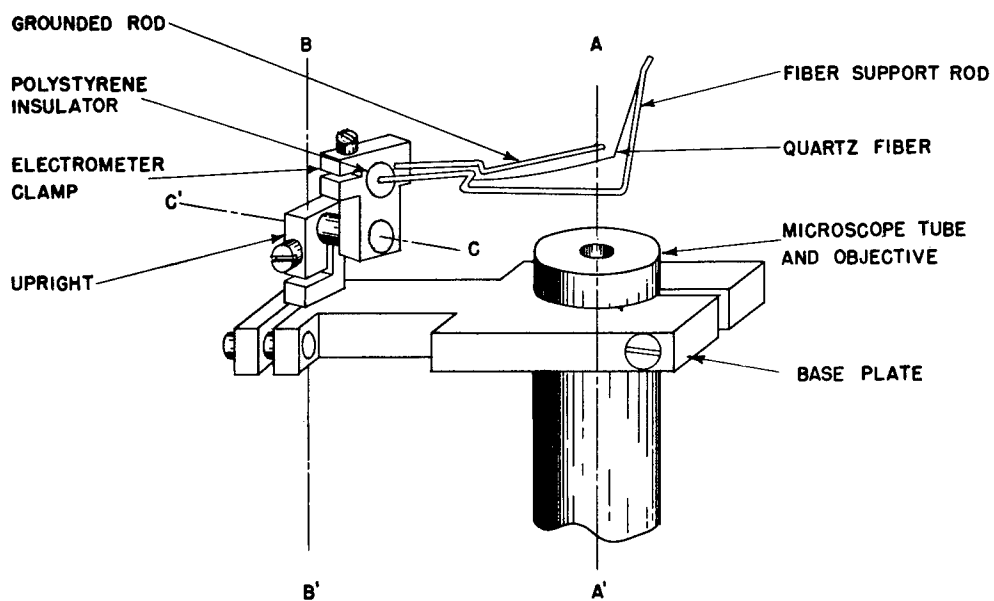

Figure 8a. Electrometer and electrometer holder.

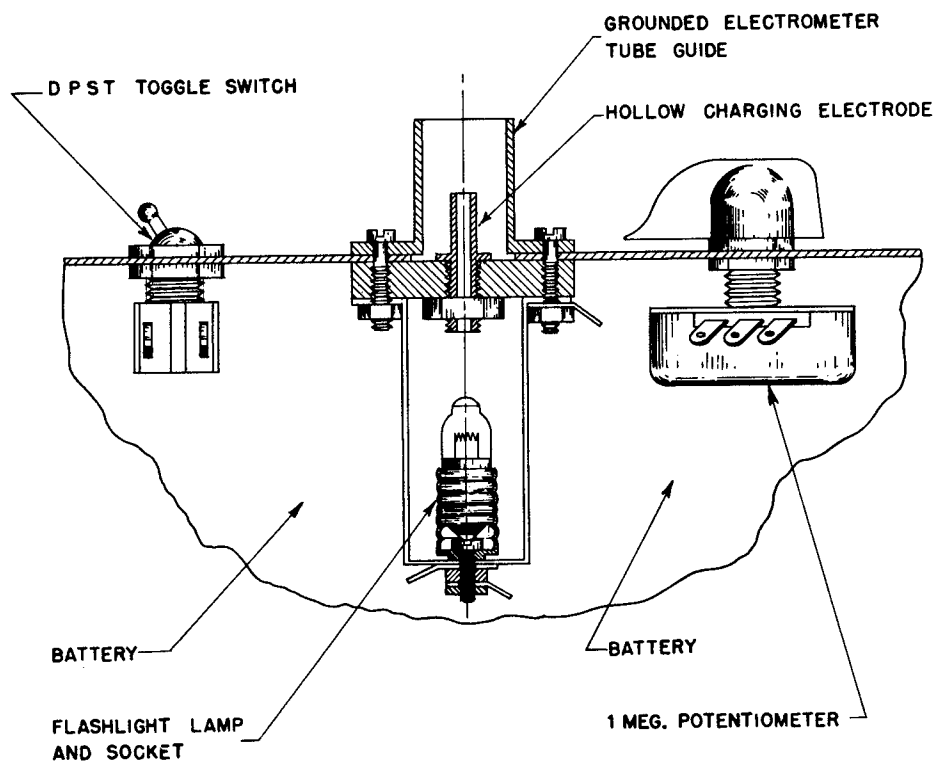

Figure 8b. Pocket electroscope charging box.

A note should be included here on insulators. The insulators in these meters must, of course, be very good. In particular, they must be able to withstand high humidity without failure. It is well known that polystyrene, if highly polished, is very resistant to failure from this source. The problem is to secure such a polish or glaze and still keep the insulator surface clean.

A method that is simple and, from limited experience with it, seems to be satisfactory is to first wash the insulator thoroughly in clean absolute alcohol. This, among other things, removes any surface film of moisture. It is then immediately immersed in a solution of clean benzene in alcohol. Polystyrene is highly soluble in benzene, very slightly soluble in alcohol. Immersion for fifteen seconds in a 60% solution of benzene is about right. Too long exposure may cause dissolved polystyrene to dry unevenly on the insulator, too short will fail to produce a satisfactory glaze.

This method has not been thoroughly tested and the technique certainly can be improved. However, insulators so treated have been suspended in saturated air for nine days with no apparent lowering of their resistance.

4. Fast Neutron-Gamma Ray Survey Meter

Fast neutrons produce their effect in tissue primarily through the ionization that results from proton recoils. The damage to tissue resulting from a given ionization per gram has been found to be in general greater for fast neutrons than for X or gamma radiation (from 2 to 10 times, depending on the type of tissue or organism irradiated). It has been generally agreed that the tolerance ionization resulting from fast neutrons should be maintained 4 to 5 times lower than for the same ionization produced by X or gamma radiation. With 0.1 r/day as the tolerance for gamma rays, we would then have from 0.020 to 0.025 roentgen equivalents per day for fast neutrons. It can be shown that a neutron flux over the body of from 200 to 250 neutrons/cm²/sec (~2 Mev) for 8 hours per day corresponds to the daily tolerance limits mentioned previously.

The smaller tolerance ionization makes it necessary that a survey meter for neutrons be made such that (a) neutron dosage rates can be measured independently in a mixed beam of neutrons and other radiations; or (b) the meter be made sufficiently more sensitive to neutrons than to other radiations so as to make allowance for their greater biological effectiveness.

To measure neutron dosage rates independently in the presence of gamma rays, the balanced ion chamber method can be used (E. O. Wollan and Carl Gammertsfelder). In a portable meter, this method has several disadvantages. We have felt that it is probably more feasible to introduce the factor of biological effectiveness into the instrument. The meter will then read effective biological dosage of neutrons and gamma rays when mixed in any proportion. This can be accomplished by using an ion chamber filled with hydrogen to a high pressure. Since the ratio of protons to electrons in tissue is about one-fifth that in hydrogen, the relative ionization by neutrons and gamma rays will be five times greater in hydrogen than in tissue. This factor of five can only be achieved if the ion chamber is sufficiently large or has a sufficiently high pressure of hydrogen so that the wall effects become negligible. The ionization chamber used in the neutron meter is a steel cylinder of 500 cc filled with hydrogen to pressures between 300 and 400 pounds.

To test the relative response for neutrons and gamma rays, the ionization in such a hydrogen filled chamber was measured with a (Po-Be) neutron source of known strength and this was compared with a standard gamma-ray source. The following table gives the results of these measurements for different hydrogen pressures in the chamber:

Pressure (psi)	150	300	350	400
Neutron flux (n/cm ² /sec) giving same ionization rate as that produced by 12.5 mr/hr of gamma radiation	256	247	240	264

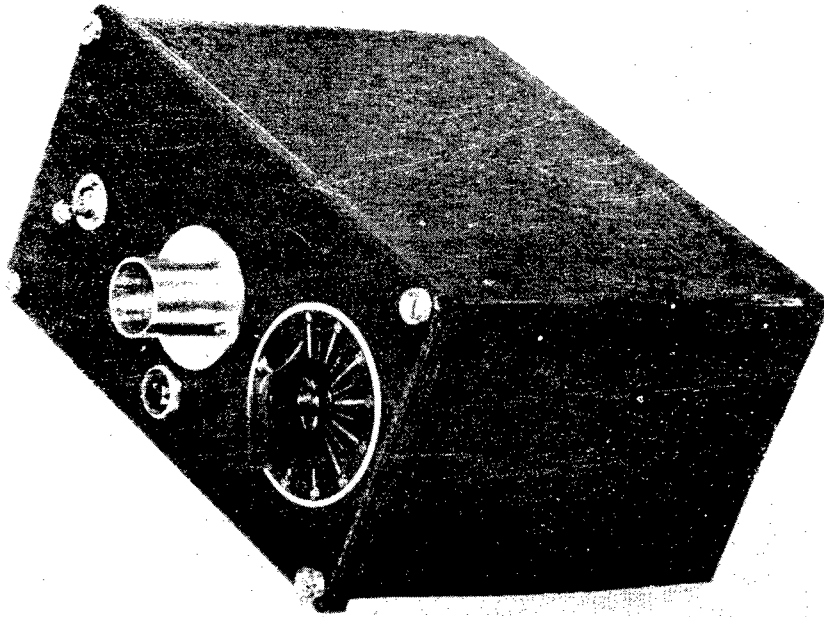

Figure 9.

It is seen that all pressures approximately 250 neutrons/cm²/sec are required. This indicates that the meter is about four times as sensitive to neutron radiation as to gamma rays when considered relative to equal tissue ionization produced by these radiations. This ratio is sufficient to make a meter which reads neutrons and gamma rays in proportion to their biological effectiveness.

The meter itself is mounted in a case of dimensions 4 by 11 by 9½ inches high (Figure 10). The electric circuit is the same as for the gamma-ray survey meter (Figure 5). The electrometer is mounted externally to the chamber on the top plate of the insulator clamp. Figure 11 is a photograph of the assembly. A section is shown in Figure 12. To insure efficient ion collection at the high gas pressure in the chamber, a potential of about 250 volts is used on the electrometer and collecting electrode.

The capacity of the electrometer system is necessarily comparatively large. The sensitivity of the six micron diameter 20 mm long fiber is about ten volts for full scale and full scale in 120 seconds at an ionization rate equal to that produced by 12.5 mr/hr of gamma rays.

5. The Alpha Ray Meter

The design of this meter was undertaken to fill a need by members of the biology department for a simple method of measuring small quantities of uranium by its alpha ray activity. The whole assembly, exclusive of potential sources which are in a small separate box, is mounted on a tripod base with the microscope set at a 45 degree angle for convenient table use. The aluminum lined brass ionization chamber is about three inches in diameter and two inches deep. A door near the bottom allows the insertion of samples on stainless steel dishes.

The electrometer is mounted in a separate compartment which is fastened to the top of the ionization chamber. As in the survey meter, the fiber is kept fully charged except when a reading is being taken. The power source for the microscope light is a 6 v transformer. The light can therefore be on continuously while the instrument is in use.

The 7-micron diameter 22½ mm long fiber has a voltage sensitivity of 10 volts for full scale and a current sensitivity of 100 seconds for full scale for gamma radiation of 12.5 mr/hr. One microgram of uranium in the chamber gives a deflection of 0.03 divisions per minute on a 100 division scale (one microgram of uranium produces 1.47 alpha particles per minute and an ionization rate which is roughly equivalent to the ionization rate of 0.005 mr/hr). The natural background of the instrument is about 7 micrograms equivalent. It was found from about twenty 30-minute runs that the mean deviation from the average value was less than 1/2 microgram. One out of five runs had an error of 1 microgram or over and the largest error recorded was 1.4 microgram. These errors are nearly, if not entirely, independent of the activity of the sample in the range from one to fifty micrograms of uranium.

6. The Direct Reading Gamma-Ray Survey Meter

This meter differs from the survey meter described previously in that the electrometer is not cut free from the potentiometer voltage, but the ionization current is passed through a resistor of 10^{11} to 2×10^{12} ohms (stable resistors of such values have recently been developed by the Victoreen Company). With a one liter chamber, a radiation rate of 12.5 mr/hr produces an ion current of about 10^{-12} amperes. The range of resistance mentioned above will therefore produce a variation of voltage of 0.1 to 2 volts on the electrometer fiber. This may be translated into a deflection of one tenth of full scale for a radiation rate of 12.5 mr/hr. The fiber requires a certain time to indicate any new rate of radiation. This time varies directly as the electrometer capacity and as the circuit resistance. It is about ten seconds in the two units that have been built.

Ninety volts of B-Battery and two No. 2 flash cells for microscope illumination make the meter entirely portable. The circuit is so arranged that the resistor can be shorted out and the fiber reset to zero by means of a combination potentiometer and switch.

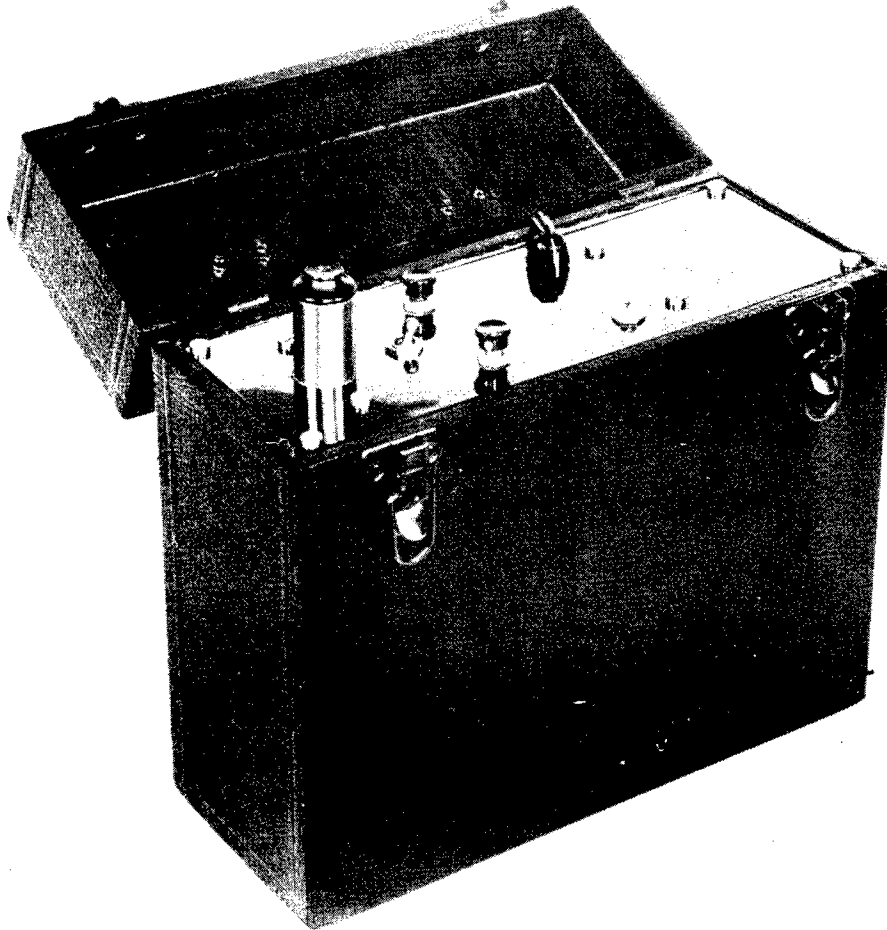

Figure 10.

7. The Laboratory Type Gamma-Ray Meter

The meter was designed to fill the need of members of Dr. L. A. Pardue's group for a better meter than is now available for calibrating radium sources. Preliminary reports indicate that a more accurate job can be done with it than with the gamma-ray survey meter that was previously used.

The instrument differs in no essential respect from the gamma-ray survey meter. It is, however, adapted to its special use in the following ways: A more sensitive electrometer and a longer chamber gives four times the current sensitivity; a collecting electrode that extends from the electrometer coaxially with the chamber and a higher voltage on the same diameter chamber increase the efficiency of collection at higher rates of radiation (160 v versus 130 v on a 3-inch chamber); a radio A-Battery instead of flash cells to permit leaving the microscope light on for extended periods without too frequent battery replacement; a standard ten power microscope objective and a 15 power eyepiece for sharper fiber image and increased accuracy. The meter was to be used on a carriage of eye height so the microscope was made to extend horizontally from the case.

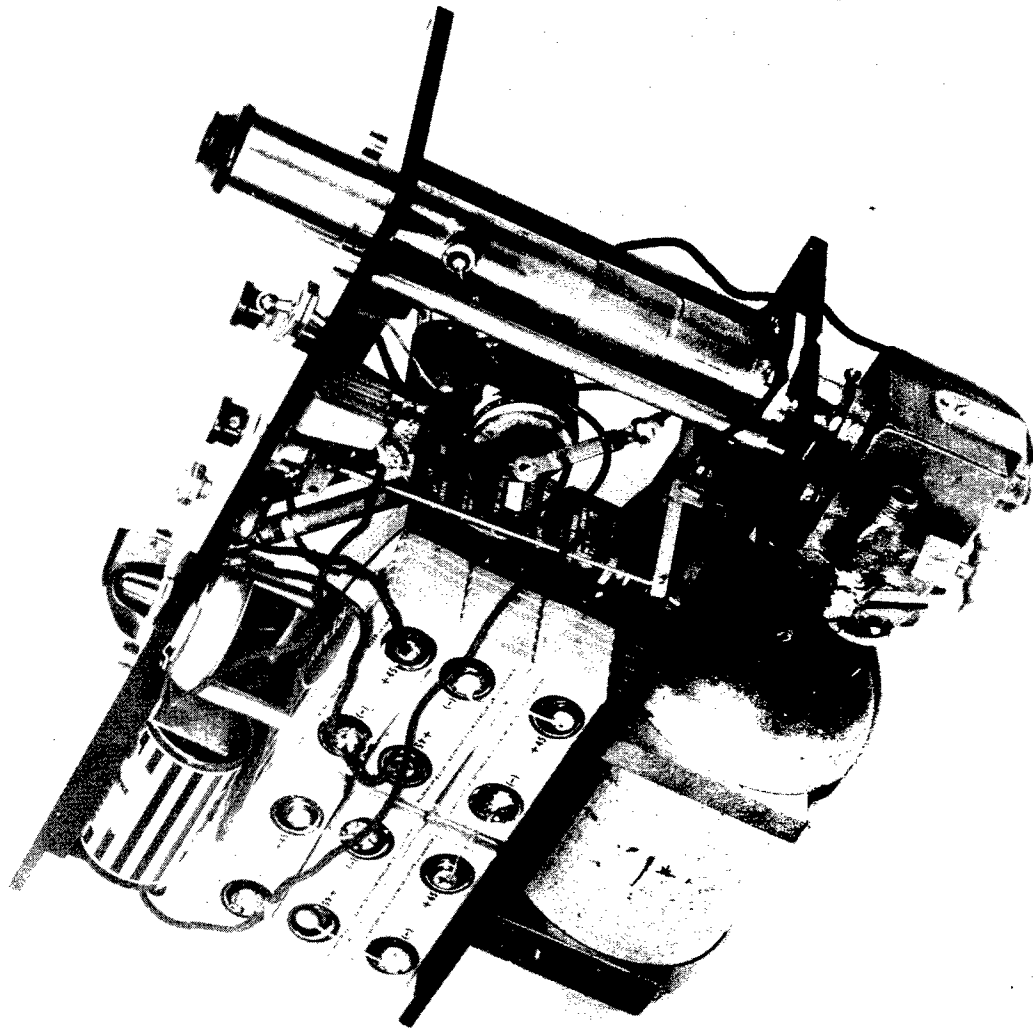

Figure 11.

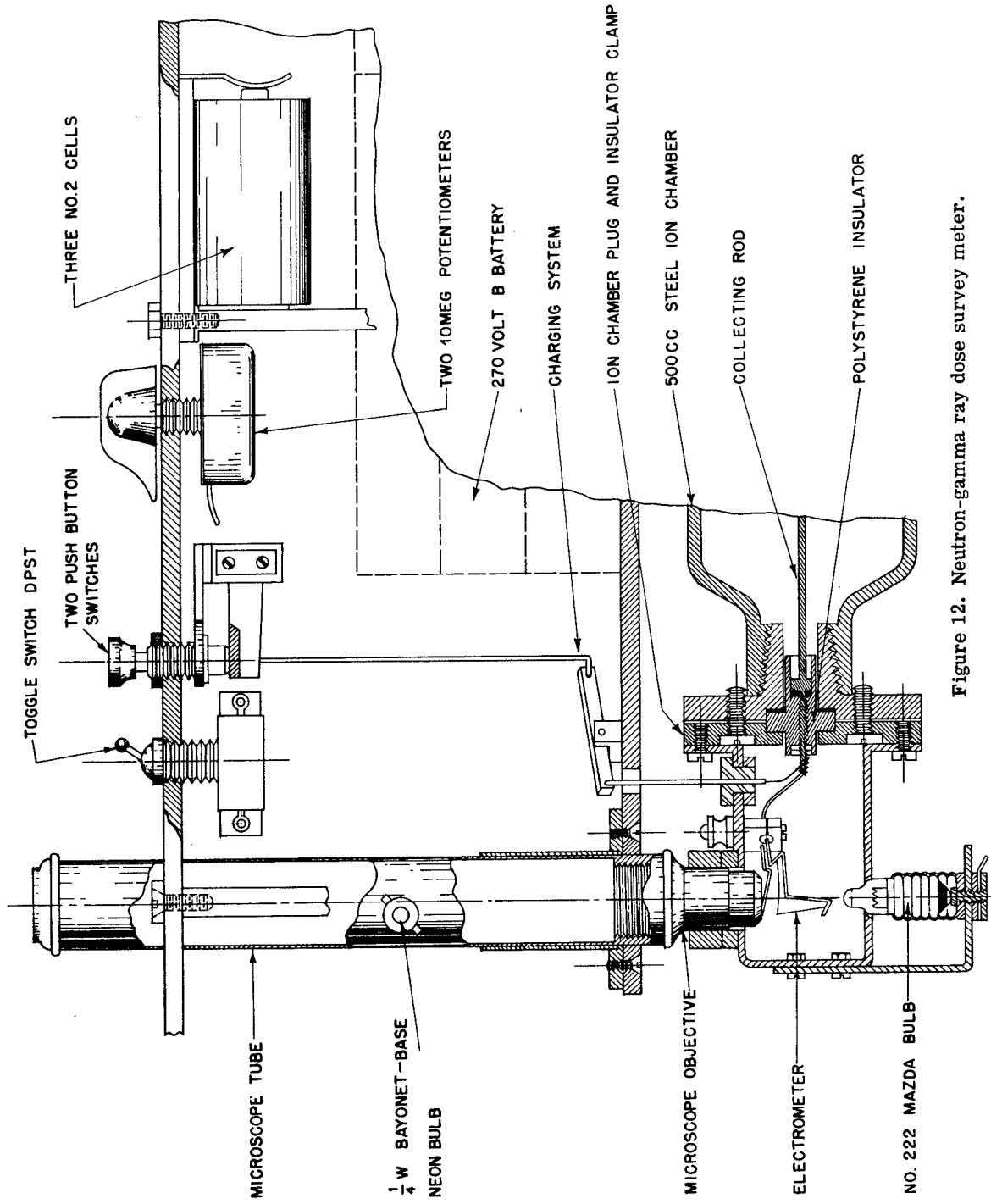

Figure 12. Neutron-gamma ray dose survey meter.

8. The Air-tight Pocket Chamber and the Projection Type Electrometer Unit

This instrument was worked out with Dr. Pardue and will be described in a separate report. It is listed here only to give completeness to the report on the electrometer instrument developments.

ADDENDUM

Since about March 1st, J. S. Blair has been very ably assisting in making electrometer units and in assembling instruments. A tabulation of the number of instruments of each type that have been built to date or are under construction follows:

No.	Name	Number built	Under construction
1	Gamma-Beta Survey	7	4
2	Small Gamma Pocket Survey	3	2
3	Gamma Pocket Dosimeter	7	50
4	Neutron-Gamma Survey	1	2
5	Alpha Ray	1	
6	Direct Reading Gamma Survey	2	
7	Lab. Type Gamma	1	
8	Projection Electrometer	1	

END OF DOCUMENT