

Research and Development



# Samplers and Sampling Procedures for Hazardous Waste Streams

87049R01  
ORIGINAL

**DISTRIBUTION STATEMENT A**  
Approved for public release  
Distribution Unlimited

Rocky Mountain Arsenal  
Information Center  
Commerce City, Colorado

FILE COPY

19970207 141

DRG QUALITY INSPECTED 1



## RESEARCH REPORTING SERIES

Research reports of the Office of Research and Development, U.S. Environmental Protection Agency, have been grouped into nine series. These nine broad categories were established to facilitate further development and application of environmental technology. Elimination of traditional grouping was consciously planned to foster technology transfer and a maximum interface in related fields. The nine series are:

1. Environmental Health Effects Research
2. Environmental Protection Technology
3. Ecological Research
4. Environmental Monitoring
5. Socioeconomic Environmental Studies
6. Scientific and Technical Assessment Reports (STAR)
7. Interagency Energy-Environment Research and Development
8. "Special" Reports
9. Miscellaneous Reports

This report has been assigned to the ENVIRONMENTAL PROTECTION TECHNOLOGY series. This series describes research performed to develop and demonstrate instrumentation, equipment, and methodology to repair or prevent environmental degradation from point and non-point sources of pollution. This work provides the new or improved technology required for the control and treatment of pollution sources to meet environmental quality standards.

EPA-600/2-80-018  
January 1980

SAMPLERS AND SAMPLING PROCEDURES FOR HAZARDOUS WASTE STREAMS

by

Emil R. deVera, Bart P. Simmons,  
Robert D. Stephens and David L. Storm  
California Department of Health Services  
Berkeley, California 94704

Grant No. R804692010

Project Officer

Richard A. Carnes  
Solid and Hazardous Waste Research Division  
Municipal Environmental Research Laboratory  
Cincinnati, Ohio 45268

MUNICIPAL ENVIRONMENTAL RESEARCH LABORATORY  
OFFICE OF RESEARCH AND DEVELOPMENT  
U.S. ENVIRONMENTAL PROTECTION AGENCY  
CINCINNATI, OHIO 45268

## DISCLAIMER

This report has been reviewed by the Municipal Environmental Research Laboratory, U.S. Environmental Protection Agency, and approved for publication. Approval does not signify that the contents necessarily reflect the views and policies of the U.S. Environmental Protection Agency, nor does mention of trade names or commercial products constitute endorsement or recommendation for use.

## FOREWORD

The Environmental Protection Agency was created because of increasing public and government concern about the dangers of pollution to the health and welfare of the American people. Noxious air, foul water, and spoiled land are tragic testimony to the deterioration of our natural environment. The complexity of that environment and the interplay between its components require a concentrated and integrated attack on the problem.

Research and development is that necessary first step in problem solution and it involves defining the problem, measuring its impact, and searching for solutions. The Municipal Environmental Research Laboratory develops new and improved technology and systems for the prevention, treatment, and management of wastewater and solid and hazardous waste pollutant discharges from municipal and community sources, for the preservation and treatment of public drinking water supplies, and to minimize the adverse economic, social, health, and aesthetic effects of pollution. This publication is one of the products of that research; a most vital communications link between the researcher and the user community.

This study involved the development of simple but effective sampling equipment and procedures for collecting, handling, storing, and recording of hazardous wastes. A variety of sampling devices were developed and/or selected to meet the needs of those who regulate and manage hazardous wastes. Of particular importance is the development of the composite liquid waste sampler, the Coliwasa. The sampling procedures developed were designed to provide maximum protection for the sample collector, collection of representative samples of the bulk of wastes, and proper containment, identification, preservation, and handling of the samples.

Francis T. Mayo, Director  
Municipal Environmental Research  
Laboratory

## ABSTRACT

The goal of this project was to develop simple but effective sampling equipment and procedures for collecting, handling, storing, and recording samples of hazardous wastes. The report describes a variety of sampling devices designed to meet the needs of those who regulate and manage hazardous wastes. Particular emphasis is given to the development of a composite liquid waste sampler, the Coliwasa. This simple device is designed for use on liquid and semi-liquid wastes in a variety of containers, tanks, and ponds. Devices for sampling solids and soils are also described.

In addition to the sampling devices, the report describes procedures for development of a sampling plan, sample handling, safety precautions, proper recordkeeping and chain of custody, and sample containment, preservation, and transport. Also discussed are certain limitations and potential sources of error that exist in the sampling equipment and the procedures. The statistics of sampling are covered briefly, and additional references in this area are given.

This report was submitted in partial fulfillment of Research Grant No. R804692010 by the California Department of Health Services under sponsorship of the U.S. Environmental Protection Agency.

## CONTENTS

Foreword . . . . .	iii
Abstract . . . . .	iv
Figures . . . . .	vi
Tables . . . . .	vii
1. Introduction . . . . .	1
2. Conclusions . . . . .	3
3. Recommendations . . . . .	4
4. Samplers . . . . .	5
Composite liquid waste sampler . . . . .	5
Solid waste samplers . . . . .	9
Soil samplers . . . . .	13
Procedure for use . . . . .	14
Pond sampler . . . . .	20
5. Preparation for Sampling . . . . .	24
6. Sampling Procedures . . . . .	26
General considerations . . . . .	26
Sample handling . . . . .	39
Field log book . . . . .	41
Chain of custody record . . . . .	42
Sample analysis request sheet . . . . .	42
Sample delivery to the laboratory . . . . .	42
Shipping of sample . . . . .	45
7. Receipt and Logging of Sample . . . . .	46
8. Preservation and Storage of Samples . . . . .	48
References . . . . .	50
Appendices . . . . .	52
A. Development of the composite liquid waste sampler (Coliwasa) . . . . .	52
B. Parts for constructing the coliwasa . . . . .	62
C. Checklist of items required in the field sampling of hazardous wastes . . . . .	63
D. Random sampling . . . . .	67
E. Systematic errors in using the coliwasa . . . . .	68

## FIGURES

Number		Page
1	Composite liquid waste sampler (Coliwasa) . . .	6
2	Grain sampler . . . . .	10
3	Sampling trier . . . . .	11
4	Trowel or scoop with calibrations . . . . .	13
5	Soil auger . . . . .	15
6	Veihmeyer sampler . . . . .	16
7	Waste pile sampler . . . . .	20
8	Pond sampler . . . . .	21
9	Weighted bottle sampler . . . . .	23
10	Example of waste manifest . . . . .	28
11	Official sample label . . . . .	40
12	Example of official sample seal . . . . .	40
13	Example of chain of custody record . . . . .	43
14	Example of hazardous waste sample analysis request sheet . . . . .	44
A-1	Coliwasa, Model 1 . . . . .	53
A-2	Coliwasa, Model 2 . . . . .	55
A-3	Coliwasa, Model 3 . . . . .	56
A-4	Coliwasa, Model 4 . . . . .	58
A-5	Coliwasa, Model 5 . . . . .	58

TABLES

<u>Number</u>		<u>Page</u>
1	Basic Parts and Costs of a Veihmeyer Soil Sampler . . .	17
2	Basic Parts and Approximate Costs of a Pond Sampler . . . . .	21
3	Samplers Recommended for Various Types of Waste . . . .	29
4	Sample Containers and Closures Recommended for Various Types of Waste . . . . .	31
5	Sampling Points Recommended for Most Waste Containers . . . . .	32
6	Number of Samples to be Collected . . . . .	34
7	Respiratory Protective Devices Recommended for Various Hazards . . . . .	35
8	Methods of Preservation for Hazardous Wastes . . . . .	49
A-1	Relative Volumes of Liquids in the Two-Phase Mixture . . . . .	60
A-2	Relative Volumes of Liquids in the Three-Phase Mixture . . . . .	60
APPENDIX B.	Parts for Constructing the Coliwasa . . . . .	62
APPENDIX C.	Checklist of Items Required in the Field Sampling of Hazardous Wastes. . . . .	63, 64, 65, 66
APPENDIX D.	Random Sampling . . . . .	67
APPENDIX E-1	Sample Volume . . . . .	69

## SECTION 1

### INTRODUCTION

The growth in the size and complexity of industry and the implementation of air and waste pollution abatement technology has confronted the nation with the immensely difficult problem of managing large volumes of waste products that are often toxic, flammable, corrosive, and explosive. The problem is further exacerbated by the complexity of the waste. This difficult situation is now being addressed at many levels of government through a variety of regulatory agencies. Solution is being sought through a "cradle-to-grave" regulation of waste generation, transport, reprocessing, and disposal. Significant progress toward a solution is also being made by the private waste management industry with improved techniques in handling, resource recovery, and disposal.

The management of hazardous wastes may be addressed primarily as a chemical problem. With this approach, management decisions must be founded on proper knowledge of waste chemical compositions. Defining the information needed on waste composition to support management decisions presents an additional complication, for such information varies with waste type and with handling or disposal objectives. Regardless of the details, the required information results from chemical and physical testing of the waste.

Industrial waste predominantly occurs in volumes that are large enough to preclude testing or analysis of the entire body of the waste. Obtaining samples adequate in size for the required testing and representative of the bulk volumes of the wastes is therefore necessary. The obtainment of such representative samples presents special problem, for many wastes are complex, multiphase mixtures that vary greatly in viscosity, corrosivity, volatility, flammability, or capability to generate toxic gases.

This study was conducted to develop specialized equipment and procedures designed to handle the widest possible variety of waste sampling situations.

The equipment and procedures that have been developed and described in this report had their origins in the hazardous waste regulatory program of the California Department of Health Services. Early in this program, the necessity of reliable analytical data on waste composition became apparent. As a result, the problem of proper sampling of hazardous

wastes was addressed. Review of the wide variety of industrial wastes produced in California revealed that liquids or liquid-sludge mixtures accounted for the greatest volume of wastes. Most of these materials at some point are contained and/or transported in tank (vacuum) trucks or barrels. A primary concern, therefore, was to develop the capability for sampling these wastes.

The first prototype of a liquid waste sampler was the tube sampler, which was designated the composite liquid waste sampler or Coliwasa.<sup>1</sup> This sampling device, fabricated from readily available materials, was taken to the field and tested for its usability and reliability.

The first large-scale sampling of hazardous wastes was conducted jointly by the California Department of Health Services and the University of Southern California under the sponsorship of the U.S. Environmental Protection Agency (EPA)<sup>2</sup> In this sampling program, approximately 400 waste samples were collected. These samples varied greatly in composition and in physical characteristics.

Approximately 90% of all wastes sampled were liquids or sludges and could be sampled with the Coliwasa. The sampling program established the utility of this sampler. In addition, however, several deficiencies and needed improvements were demonstrated. Along with the need for liquid sampling equipment, a need was also demonstrated for simple but effective equipment for sampling solids, soils, and liquids in large tanks or ponds. This early study also clearly indicated the need for development of good safety procedures and sample handling, preservation, and custody procedures.

In November 1976, under a grant from the EPA, the California Department of Health Services embarked on a development program to establish recommended procedures and equipment for the sampling of hazardous wastes. Commercially available liquid samplers were investigated, but none was found to be adaptable to sampling hazardous wastes. Equipment development centered on the Coliwasa, which had been conceived and initially designed by waste management personnel of the Department. Solid, soil, and pond sampling equipment was obtained after an extensive review of the literature and testing of available equipment for efficiency. Criteria used in choosing candidate procedures were ready availability, reasonable cost, simplicity of design and operation, and chemical inertness. Candidate methods and samplers were subjected to laboratory and field tests. Laboratory tests for the liquid samplers consisted of sampling water as well as multiphase waste mixtures. The samplers were examined for leakage, ease of use and transfer, and cross contamination. In field tests, the samplers for liquids and solids were used on actual wastes existing in a variety of containers, ponds, or soils.

The body of the report gives detailed discussions of recommended samplers, preparation for sampling, sampling procedures, sample handling, and recordkeeping. The appendices present a variety of practical support data for the body of the report.

## SECTION 2

### CONCLUSIONS

The present study was designed to develop simple but effective sampling equipment for collecting representative samples of hazardous wastes. In addition, recommended procedures for sample collection, handling, storage, and recording were to be developed. These primary objectives have been met, and the resulting sampling equipment and procedures are presented here.

The sampling equipment and procedures were designed to insure the widest possible applicability in the sampling of various types of hazardous wastes. The methods, however, are not intended to cover all possible sampling situations. Professional judgment on applicability must be exercised.

## SECTION 3

### RECOMMENDATIONS

The next step in the development of standardized sampling methods should be user verification. Additional data on applicability, reliability, and other performance characteristics need to be developed before these recommended methods can become standard methods. This next phase will require considerable effort by a large number of collaborators, for the methodology described in this report is intended to be satisfactory for essentially the entire waste-producing industry. Significant benefit is to be gained by both industry and environmental regulatory agencies if efficient, reliable hazardous waste sampling methods can be established. We therefore strongly recommend that work on this validation begin immediately.

## SECTION 4

### SAMPLERS

Sampling of hazardous wastes requires different types of samplers. Some of these samplers are commercially available, but the others have to be fabricated. This section lists and describes suitable samplers. Their uses and commercial availability as well as directions for their use are reported. Directions for fabricating the commercially unavailable samplers are also outlined.

#### COMPOSITE LIQUID WASTE SAMPLER (COLIWASA)

The Coliwasa is the single most important hazardous waste sampler discussed in this report. It was chosen from a number of other liquid samplers, based on laboratory and field tests, as the most practical. It permits the representative sampling of multiphase wastes of a wide range of viscosity, corrosivity, volatility, and solids content. Its simple design makes it easy to use and allow the rapid collection of samples, thus minimizing the exposure of the sample collector to potential hazards from the wastes. The sampler is not commercially available, but it is relatively easy and inexpensive to fabricate. The cost of fabrication is low enough that the contaminated parts may be discarded after a single use when they cannot be easily cleaned.

The recommended model of the Coliwasa is shown in Figure 1. The history and development of this sampler is discussed in detail in Appendix A. The main parts of the Coliwasa consist of the sampling tube, the closure-locking mechanism, and the closure system.

The sampling tube consists of a 1.52-m(5-ft.) by 4.13-cm(1 5/8-in.) I.D. translucent plastic pipe, usually polyvinyl chloride (PVC) or borosilicate glass plumbing tube. The closure-locking mechanism consists of a short-length, channeled aluminum bar attached to the sampler's stopper rod by an adjustable swivel. The aluminum bar serves both as a T-handle and lock for the sampler's closure system. When the sampler is in the open position, the handle is placed in the T-position and pushed down against the locking block. This manipulation pushes out the neoprene stopper and opens the sampling tube. In the close position, the handle is rotated until one leg of the T is squarely perpendicular against the locking block. This tightly seats the neoprene stopper against the bottom opening of the sampling tube and positively locks the sampler in the close position. The closure tension can be adjusted by shortening or lengthening the stopper rod by screwing it in or out

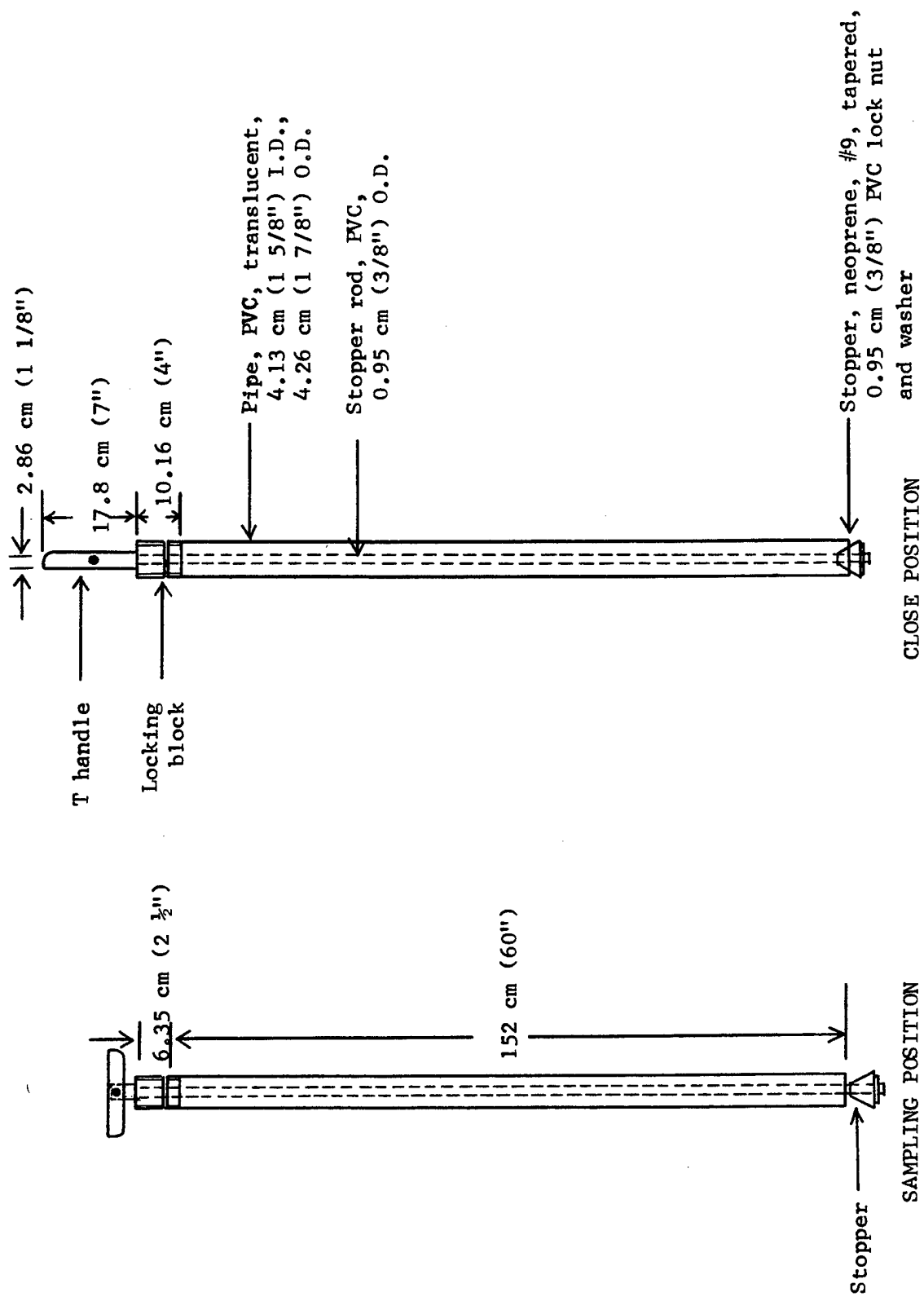

Figure 1. Composite liquid waste sampler (Collwasa)

of the T-handle swivel. The closure system of the sampler consists of a sharply tapered neoprene stopper attached to a 0.95-cm (3/8-in.) O.D. rod, usually PVC. The upper end of the stopper rod is connected to the swivel of the aluminum T-handle. The sharply tapered neoprene stopper can be fabricated according to specifications by plastic products manufacturers at an extremely high price, or it can be made in-house by grinding down the inexpensive stopper with a shop grinder as described in Note 1 of Appendix B.

Two types of Coliwasa samplers are made, namely plastic or glass. The plastic type consists of translucent plastic (usually PVC) sampling tube. The glass Coliwasa uses borosilicate glass plumbing pipe as the sampling tube and Teflon plastic stopper rod.

The complete list of parts for constructing the two types of Coliwasa samplers is given in Appendix B. The suppliers and approximate costs of the parts as well as the directions for fabricating the commercially unavailable parts are also given.

The sampler is assembled as shown in Figure 1 and as follows:

1. Attach the swivel to the T-handle with the 3.18 cm (1¼ in.) long bolt and secure with the 0.48 cm (3/16 in.) National Coarse (NC) washer and lock nut.
2. Attach the neoprene stopper to one end of the stopper rod and secure with the 0.95 cm (3/8 in.) washer and lock nut.
3. Install the stopper and stopper rod assembly in the sampling tube.
4. Secure the locking block sleeve on the block with glue or screws. This block can also be fashioned by shaping a solid plastic rod on a lathe to the required dimensions.
5. Position the locking block on top of the sampling tube such that the sleeveless portion of the block fits inside the tube, the sleeve sits against the top end of the tube, and the upper end of the stopper rod slips through the center hole of the block.
6. Attach the upper end of the stopper rod to the swivel of the T-handle.
7. Place the sampler in the close position and adjust the tension on the stopper by screwing the T-handle in or out.

#### Uses

The plastic Coliwasa is used to sample most containerized liquid wastes except wastes that contain ketones, nitrobenzene, dimethylformamide, mesityl oxide, and tetrahydrofuran.<sup>3,4</sup>

The glass Coliwasa is used to sample all other containerized liquid wastes that cannot be sampled with the plastic Coliwasa except strong alkali and hydrofluoric acid solutions.

#### Procedure for Use

1. Choose the plastic or glass Coliwasa for the liquid waste to be sampled and assemble the sampler as shown in Figure 1.
2. Make sure that the sampler is clean (see Section 5).
3. Check to make sure the sampler is functioning properly. Adjust the locking mechanism if necessary to make sure the neoprene rubber stopper provides a tight closure.
4. Wear necessary protective clothing and gear and observe required sampling precautions (see Section 6).
5. Put the sampler in the open position by placing the stopper rod handle in the T-position and pushing the rod down until the handle sits against the sampler's locking block.
6. Slowly lower the sampler into the liquid waste. (Lower the sampler at a rate that permits the levels of the liquid inside and outside the sampler tube to be about the same. If the level of the liquid in the sampler tube is lower than that outside the sampler, the sampling rate is too fast and will result in a nonrepresentative sample).
7. When the sampler stopper hits the bottom of the waste container, push the sampler tube downward against the stopper to close the sampler. Lock the sampler in the close position by turning the T handle until it is upright and one end rests tightly on the locking block.
8. Slowly withdraw the sampler from the waste container with one hand while wiping the sampler tube with a disposable cloth or rag with the other hand.
9. Carefully discharge the sample into a suitable sample container (see Section 6) by slowly opening the sampler. This is done by slowly pulling the lower end of the T handle away from the locking block while the lower end of the sampler is positioned in a sample container.
10. Cap the sample container; attach label and seal; record in field log book; and complete sample analysis request sheet and chain of custody record.

11. Unscrew the T handle of the sampler and disengage the locking block. Clean sampler on site (see Section 5) or store the contaminated parts of the sampler in a plastic storage tube for subsequent cleaning. Store used rags in plastic bags for subsequent disposal.
12. Deliver the sample to the laboratory for analysis (see Section 6).

#### SOLID WASTE SAMPLERS

A number of tools are available for sampling solid substances. The most suitable of these for sampling hazardous solid wastes are the grain sampler, sampling trier, and the trowel or scoop.

##### Grain Sampler

The grain sampler (Figure 2) consists of two slotted telescoping tubes, usually made of brass or stainless steel. The outer tube has a conical, pointed tip on one end that permits the sampler to penetrate the material being sampled. The sampler is opened and closed by rotating the inner tube. Grain samplers are generally 61 to 100 cm (24 to 40 in.) long by 1.27 to 2.54 cm ( $\frac{1}{2}$  to 1 in.) in diameter, and they are commercially available at laboratory supply houses.

##### Uses--

The grain sampler is used for sampling powdered or granular wastes or materials in bags, fiberdrums, sacks or similar containers. This sampler is most useful when the solids are no greater than 0.6 cm ( $\frac{1}{4}$  in.) in diameter.

##### Procedure for Use--

1. While the sampler is in the close position, insert it into the granular or powdered material or waste being sampled from a point near a top edge or corner, through the center, and to a point diagonally opposite the point of entry.<sup>5</sup>
2. Rotate the inner tube of the sampler into the open position.
3. Wiggle the sampler a few times to allow materials to enter the open slots.
4. Place the sampler in the close position and withdraw from the material being sampled.
5. Place the sampler in a horizontal position with the slots facing upward.
6. Rotate and slide out the outer tube from the inner tube.

7. Transfer the collected sample in the inner tube into a suitable sample container (see Section 6).
8. Collect two or more core samples at different points (see Section 6), and combine the samples in the same container.
9. Cap the sample container; attach label and seal; record in field log book; and complete sample analysis request sheet and chain of custody record.
10. Clean (see Section 5) or store the sampler in plastic bag for subsequent cleaning.
11. Deliver the sample to the laboratory for analysis (see Section 6).

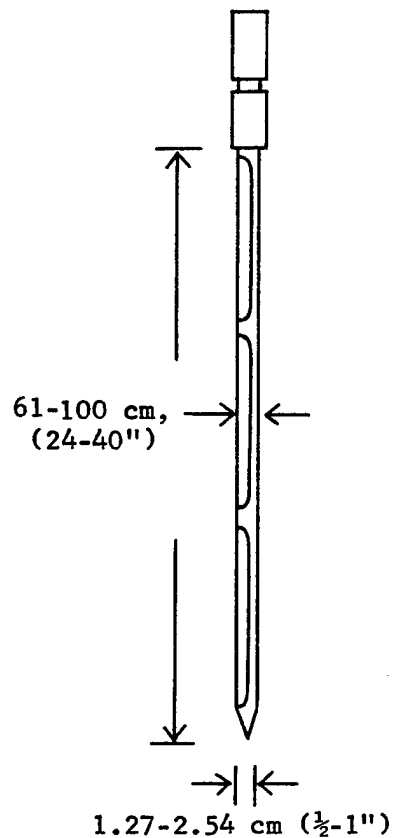

Figure 2. Grain sampler.

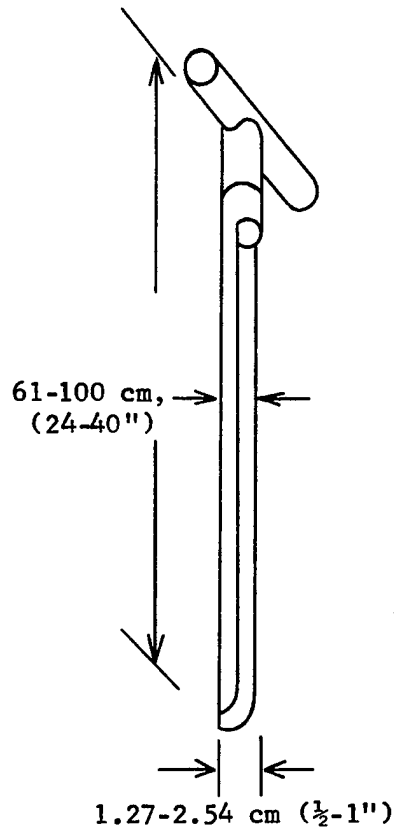

Figure 3. Sampling trier.

### Sampling trier

A typical sampling trier (Figure 3) is a long tube with a slot that extends almost its entire length. The tip and edges of the tube slot are sharpened to allow the trier to cut a core of the material to be sampled when rotated after insertion into the material. Sampling triers are usually made of stainless steel with wooden handles. They are about 61 to 100 cm (24 to 40 in.) long and 1.27 to 2.54 cm ( $\frac{1}{2}$  to 1 in.) in diameter. They can be purchased readily from laboratory supply houses.

### Uses--

The use of the trier is similar to that of the grain sampler discussed above. It is preferred over the grain sampler when the powdered or

granular material to be sampled is moist or sticky.

In addition, the sampling trier can be used to obtain soft or loosened soil samples up to a depth of 61 cm(24 in.) as outlined below.

#### Procedure for Use--

1. Insert the trier into the waste material at a 0 to 45° angle from horizontal. This orientation minimizes the spillage of sample from the sampler. Extraction of samples might require tilting of the containers.
2. Rotate the trier once or twice to cut a core of material.
3. Slowly withdraw the trier, making sure that the slot is facing upward.
4. Transfer the sample into a suitable container (see Section 6) with the aid of a spatula and/or brush.
5. Repeat the sampling at different points (see Section 6). Two or more times and combine the samples in the same sample container.
6. Cap the sample container; attach the label and seal; record in field log book; and complete sample analysis request sheet and chain of custody record.
7. Wipe the sampler clean, or store it in a plastic bag for subsequent cleaning.
8. Deliver the sample to the laboratory for analysis (see Section 6).

#### Trowel or Scoop

A garden-variety trowel looks like a small shovel (Figure 4). The blade is usually about 7 by 13 cm(3 by 5 in.) with a sharp tip. A laboratory scoop is similar to the trowel, but the blade is usually more curved and has a closed upper end to permit the containment of material. Scoops come in different sizes and makes. Stainless steel or polypropylene scoops with 7 by 15-cm(2 3/4 by 6-in.) blades are preferred. A trowel can be bought from hardware stores; the scoop can be bought from laboratory supply houses.

#### Uses--

An ordinary zinc-plated garden trowel can be used in some cases for sampling dry granular or powdered materials in bins or other shallow containers. The laboratory scoop, however, is a superior choice. It is usually made of materials less subject to corrosion or chemical reactions, thus lessening the probability of sample contamination.

The trowel or scoop can also be used in collecting top surface soil samples.

Procedure for Use--

1. At regular intervals (see Section 6), take small, equal portions of sample from the surface or near the surface of the material to be sampled.
2. Combine the samples in a suitable container (see Section 6).
3. Cap the container; attach the label and seal; record in field log book; and complete sample analysis request sheet and chain of custody record.
4. Deliver the sample to the laboratory for analysis (see Section 6).

SOIL SAMPLERS

There is a variety of soil samplers used. For taking soil core samples, the scoop, sample trier, soil auger, and Veihmeyer sampler can be used. These samplers are commercially available and relatively inexpensive.

Scoop or Trowel

See the preceding section on solid waste samplers for the description of a scoop or trowel (Figure 4).

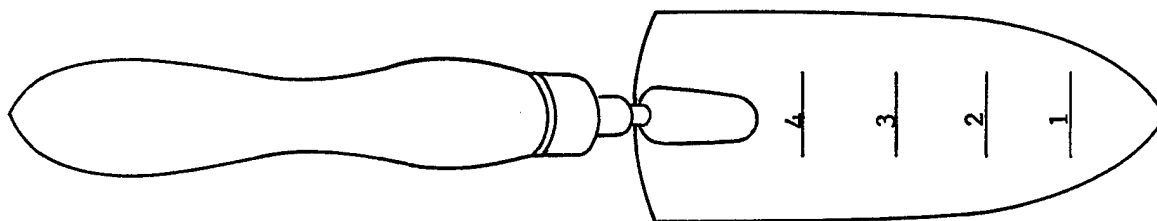

Figure 4. Trowel or scoop with calibrations.

#### Uses--

The scoop is used to collect soil samples up to 8 cm(3 in.) deep. It is simple to use, but identical mass sample units for a composite sample are difficult to collect with this sampler. The procedure for use of the scoop is outlined in the preceding section on solid waste samplers.

#### Sampling Trier

See the preceding section on solid waste samplers for the description of a sampling trier (Figure 3).

#### Uses--

This sampler can be used to collect soil samples at a depth greater than 8 cm(3 in.). The sampling depth is determined by the hardness and types of soil being sampled. This sampler can be difficult to use in stony, dry, very heavy, or sandy soil. The collected sample tends to be slightly compacted, but this method permits observation of the core sample before removal.<sup>6</sup>

#### Procedure for Use--

Procedure for use of the sampling trier can be found in the section on solid waste samplers.

#### Soil Auger

This tool consists of a hard metal central shaft and sharpened spiral blades (Figure 5). When the tool is rotated clockwise by its wooden T handle, it cuts the soil as it moves forward and discharges most of the loose soil upward. The cutting diameter is about 5 cm(2 in.). The length is about 1 m(40 in.), with graduations every 15.2 cm(6 in.). The length can be increased up to 2 m(80 in.). This tool can be bought from stores and, in some cases, from laboratory supply houses.

#### Uses--

The auger is particularly useful in collecting soil samples at depths greater than 8 cm(3 in.). This sampler destroys the structure of cohesive soil and does not distinguish between samples collected near the surface or toward the bottom. It is not recommended, therefore, when an undisturbed soil sample is desired.

#### Procedure for Use--

1. Select the sampling point (see Section 6) and remove unnecessary rocks, twigs, and other non-soil materials.

2. Install the sampler's wooden T handle in its socket.
3. Bore a hole through the middle of an aluminum pie pan large enough to allow the blades of the auger to pass through. The pan will be used to catch the sample brought to the surface by the auger.
4. Spot the pan against the selected sampling point.
5. Start augering through the hole in the pan until the desired sampling depth is reached.
6. Back off the auger and transfer the sample collected in the catch pan and the sample adhering to the auger to a suitable container (see Section 6). Spoon out the rest of the loosened sample with a sampling trier.
7. Repeat the sampling at different sampling points (see Section 6), and combine the samples in the same container as in step 6.
8. Cap the sample container; attach label and seal; record in field log book; and complete sample analysis request sheet and chain of custody record.
9. Brush off and wipe the sampler clean, or store it in a plastic bag for subsequent cleaning.
10. Deliver the sample to the laboratory for analysis (see Section 6).

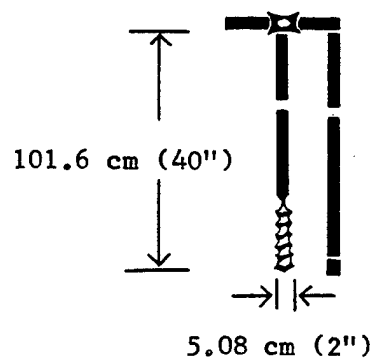

Figure 5. Soil auger.

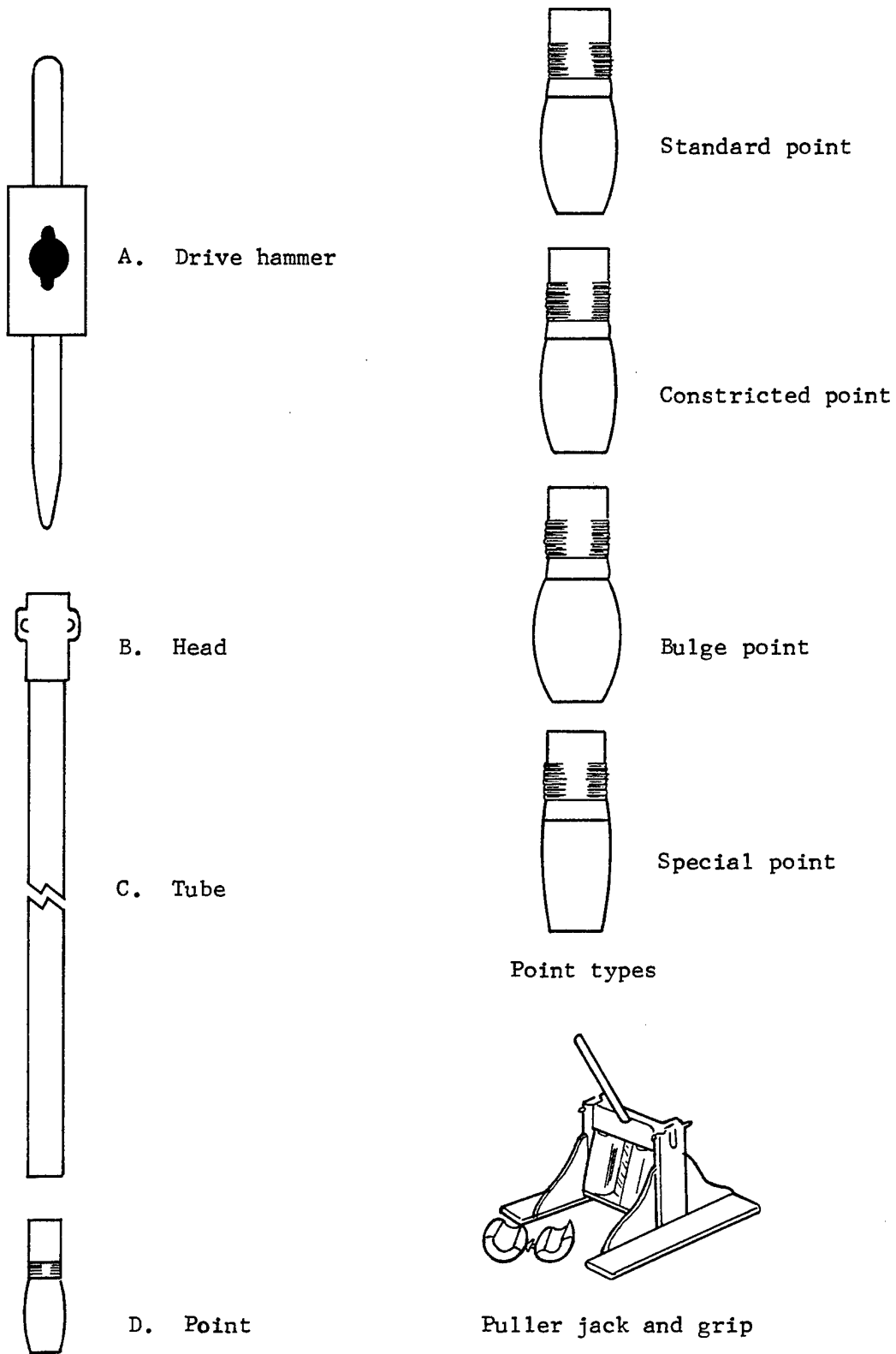

Figure 6. Veihmeyer sampler

## Veihmeyer Soil Sampler

This sampler was developed by Professor F.J. Veihmeyer of the University of California in Davis.<sup>7</sup> The parts of a basic sampler and the corresponding costs are given in Table 1, and the basic sampler is shown in Figure 6.

TABLE 1. BASIC PARTS AND COSTS OF A VEIHMAYER SOIL SAMPLER

Part <sup>a</sup>	Cost <sup>b</sup>
Tube, 1.5 m (5 ft.)	\$ 50.40
Tube, 3 m (10 ft.)	84.75
Tip, type A, general use	25.80
Drive head	29.05
Drop hammer, 6.8 kg (15 lb.)	71.85
Puller jack and grip <sup>c</sup>	<u>161.90</u>
Total	\$ 433.75

<sup>a</sup> Only one of each part is needed. They are manufactured by Hansen Machine Works, 334 N. 12th Street, Sacramento, CA 95815.

<sup>b</sup> Based on August 1, 1977, price list.

<sup>c</sup> Recommended for deep soil sampling.

The tube is chromium-molybdenum steel and comes in various standard lengths from 0.91 to 4.9 m (3 to 16 ft.) and calibrated every 30.48 cm (12 in.). Longer tubes can be obtained on special order. Different points (Figure 6) are also available for different types of soil and sampling. Each point is shaped to penetrate specific types of soil without pushing the soil ahead of it, thus preventing the core from compacting in the tube. The standard point is adequate for most general sampling purposes. The inside taper of each point is designed to keep the sample from being sucked out of the tube as it is pulled from the ground. The drive head protects the top of the tube from deforming when the tube is driven into the ground with the drive hammer. The hammer doubles as a drive weight and handle when pulling the sampler from the ground. When the sampler tube cannot be pulled easily from the ground, a special puller jack and grip

are also available. Specifications for the various parts of the Veihmeyer sampler are given as follows:

- Points . . . . . Chrome-molly steel, heat-treated. Includes a standard point for general use, a constricted point for deep sampling in heavy clay (keeps core from being sucked out of the tube), a bulge point for shallow sampling in heavy clay, and a special point for dry sand. (See Figure 6D).
- Drive hammer . . Standard weight is 6.8 kg (15 lb.). (See Figure 6A)
- Tubes . . . . . Chrome-molly steel. Maximum length is 4.9 m (16 ft.). (See Figure 6C).
- Head . . . . . Chrome-molly steel, heat-treated. (See Figure 6B).
- Puller jack . . Cast aluminum frame with steel roller assembly and handle.
- Grip . . . . . Chrome-molly steel, heat-treated.

Uses--

The Veihmeyer sampler is recommended for core sampling of most types of soil. It may not be applicable to sampling stony, rocky, or very wet soil.

Procedure for Use--

1. Assemble the sampler by screwing in the tip and the drive head on the sampling tube.
2. Insert the tapered handle (drive guide) of the drive hammer through the drive head.
3. Place the sampler in a perpendicular position on the soil to be sampled.
4. With the left hand holding the tube, drive the sampler into the ground to the desired sampling depth by pounding the drive head with the drive hammer. Do not drive the tube further than the tip of the hammer's drive guide.
5. Record the length of the tube that penetrated the ground.
6. Remove the drive hammer and fit the keyhole-like opening on the flat side of the hammer onto the drive head. In this position, the hammer serves as a handle for the sampler.

7. Rotate the sampler at least two revolutions to shear off the sample at the bottom.
8. Lower the sampler handle (hammer) until it just clears the two ear-like protrusions on the drive head and rotate about 90°.
9. Withdraw the sampler from the ground by pulling the handle (hammer) upwards. When the sampler cannot be withdrawn by hand, as in deep soil sampling, use the puller jack and grip.
10. Dislodge the hammer from the sampler; turn the sampler tube upside down; tap the head gently against the hammer; and carefully recover the sample from the tube. The sample should slip out easily.
11. Store the core sample, preferably, in a rigid, transparent, or translucent plastic tube when observation of soil layers is to be made. The use of the tube will keep the sample relatively undisturbed. In other cases, use a 1000- or 2000-ml (1-qt. or ½-gal) sample container (see Section 6) to store the sample.
12. Collect additional core samples at different points (see Section 6).
13. Label the samples; affix the seals; record in the field log book; complete analysis request sheet and chain of custody record; and deliver the samples to the laboratory for analysis (see Section 6).

#### Waste Pile Sampler

A waste pile sampler (Figure 7) is essentially a large sampling trier. It is commercially available, but it can be easily fabricated from sheet metal plastic pipe. A polyvinyl chloride plumbing pipe 1.52 m (5 ft) long by 3.2 cm (1¼ in.) I.D. by 0.32 cm (1/8 in.) wall thickness is adequate. The pipe is sawed lengthwise (about 60/40 split) until the last 10 cm (4 in.) The narrower piece is sawn off and hence forms a slot in the pipe. The edges of the slot and the tip of the pipe are sharpened to permit the sampler to cut into the waste material being sampled. The unsplit length of the pipe serves as the handle. The plastic pipe can be purchased from hardware stores.

#### Uses--

The waste pile sampler is used for sampling wastes in large heaps with cross-sectional diameters greater than 1 m (39.4 in.). It can also be used for sampling granular or powdered wastes or materials in large bins, barges, or silos where the grain sampler or sampling trier is not long enough. This sampler does not collect representative samples when the diameters of the solid particles are greater than half the diameter of the tube.

#### Procedure for Use--

1. Insert the sampler into the waste material being sampled at 0 to 45° from horizontal.
2. Rotate the sampler two or three times in order to cut a core of the material.
3. Slowly withdraw the sampler, making sure that the slot is facing upward.
4. Transfer the sample into a suitable container (see Section 6) with the aid of a spatula and/or brush.
5. Repeat the sampling at different sampling points (see Section 6) two or more times and combine the samples in the same sample container in step 4.
6. Cap the container; attach label and seal; record in field log book; and complete sample analysis request sheet and chain of custody record.
7. Wipe the sampler clean or store it in a plastic bag for subsequent cleaning.
8. Deliver the sample to the laboratory for analysis (see Section 6).

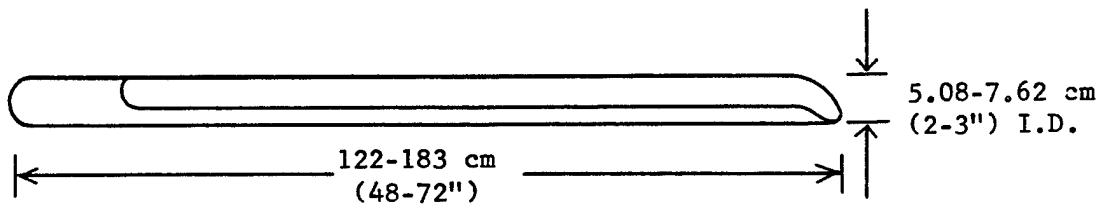

Figure 7. Waste pile sampler.

#### Pond Sampler

The pond sampler (Figure 8) consists of an adjustable clamp attached to the end of a two or three piece telescoping aluminum tube that serves as the handle. The clamp is used to secure a sampling beaker. The sampler is not commercially available, but it is easily and inexpensively fabri-

cated. The tubes can be readily purchased from most hardware or swimming pool supply stores. The adjustable clamp and sampling beaker can be obtained from most laboratory supply houses. The materials required to fabricate the sampler are given in Table 2.

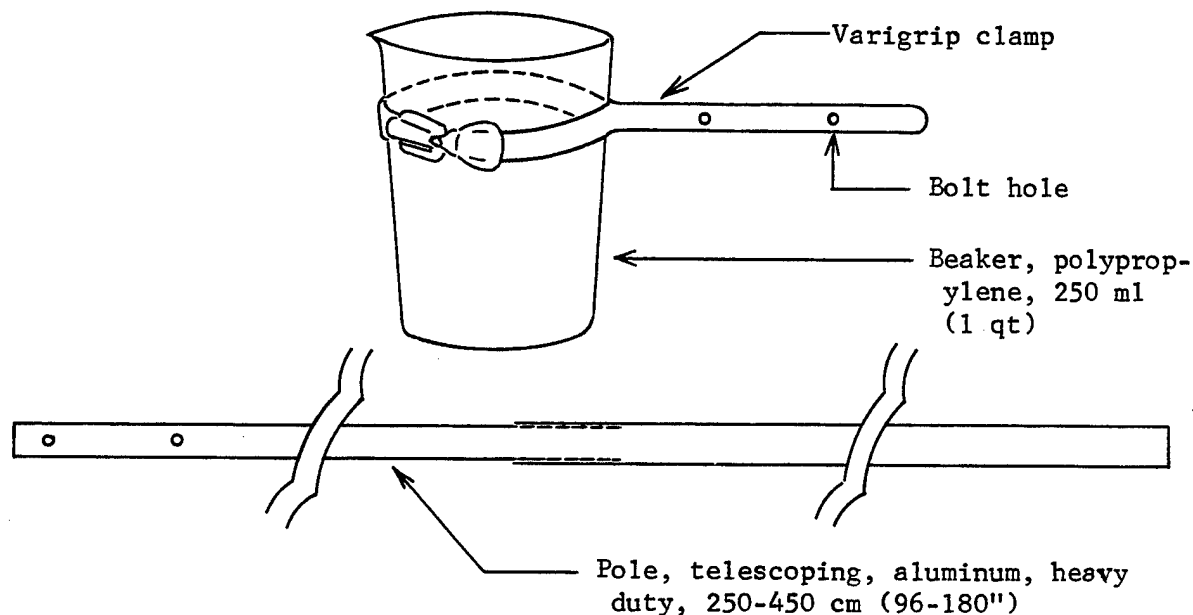

Figure 8. Pond sampler.

TABLE 2. BASIC PARTS AND APPROXIMATE COSTS OF A POND SAMPLER

Quantity	Item	Supplier	Approximate Cost
1	Clamp, adjustable, 6.4 to 8.9 cm (2½ to 3½ in.) for 250- to 600-ml (½ to 1½-pt.) beakers	Laboratory supply houses	\$ 7.00
1	Tube, aluminum, heavy duty, telescoping extends 2.5 to 4.5 m (8 to 15 ft.) with joint cam locking mechanism. Pole diameters 2.54 cm (1 in.) I.D. and 3.18 cm (1¼ in.) I.D.	Olympic Swimming Pool Co. 807 Buena Vista Street, Alameda, Calif. 94501 or other general swimming pool supply houses.	16.24
1	Beaker, polypropylene, 250-ml (½ pt.)	Laboratory supply houses.	1.00
4	Bolts, 6.35 by 0.64 cm (2½ by ¼ in.) NC	Hardware stores	.20
4	Nuts, 0.64 cm (¼ in.) NC	Hardware stores	.20
	Total		\$24.64

#### Uses--

The pond sampler is used to collect liquid waste samples from disposal ponds, pits, lagoons, and similar reservoirs. Grab samples can be obtained at distances as far as 3.5 m (11½ ft) from the edge of the ponds. The tubular aluminum handle may bow when sampling very viscous liquids if sampling is not done slowly.

#### Procedure for Use--

1. Assemble the pond sampler. Make sure that the sampling beaker and the bolts and nuts that secure the clamp to the pole are tightened properly.
2. With proper protective garment and gear (see Section 6), take grab samples from the pond at different distances and depths (see Section 6).
3. Combine the samples in one suitable container (see Section 6).
4. Cap the container; label and affix the seal; record in field log book; and complete sample analysis request sheet and chain of custody record.
5. Dismantle the sampler; wipe the parts with terry towels or rags and store them in plastic bags for subsequent cleaning. Store used towels or rags in garbage bags for subsequent disposal.
6. Deliver the sample to the laboratory for analysis (see Section 6).

#### Weighted Bottle Sampler

This sampler (Figure 9) consists of a bottle, usually glass, a weight sinker, a bottle stopper, and a line that is used to open the bottle and to lower and raise the sampler during sampling. There are a few variations of this sampler, as illustrated in the ASTM Methods D 270<sup>8</sup> and E 300<sup>9</sup>. The ASTM sampler, which uses a metallic bottle basket that also serves as weight sinker, is preferred. The weighted bottle sampler can either be fabricated or purchased.

#### Uses--

The weighted bottle sampler can be used to sample liquids in storage tanks, wells, sumps, or other containers that cannot be adequately sampled with a Coliwasa. The sampler cannot be used to collect liquids that are incompatible or that react chemically with the weight sinker and line.

#### Procedure for use--

1. Assemble the weighted bottle sampler as shown in Figure 9.

2. Using protective sampling equipment, in turn, lower the sampler to proper depths to collect the following samples:
  - a) upper sample - middle of upper third of tank contents.
  - b) middle sample - middle of tank contents.
  - c) lower sample - near bottom of tank contents.
3. Pull out the bottle stopper with a sharp jerk of the sampler line.
4. Allow the bottle to fill completely, as evidence by the cessation of air bubbles.
5. Raise the sampler and retrieve and cap the bottle. Wipe off the outside of the bottle with a terry towel or rag. The bottle can serve as the sample container.
6. Label each of the three samples collected; affix seal; fill out sample analysis request sheet and chain of custody record; record in the field log book.
7. Clean onsite or store contaminated sampler in a plastic bag for subsequent cleaning.
8. Deliver the sample to the laboratory for analysis (see Section 6). Instruct the laboratory to perform analysis on each sample or a composite of the samples.

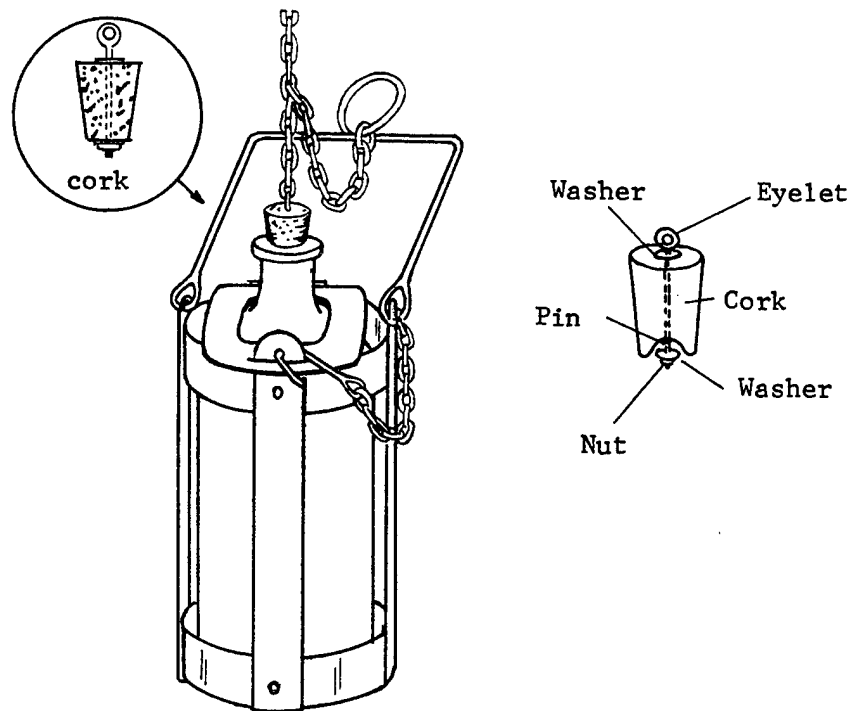

1000-ml (1-quart) weighted  
bottle catcher

Figure 9. Weighted bottle sampler.

## SECTION 5

### PREPARATION FOR SAMPLING

#### GENERAL CONSIDERATIONS

Adequate preparation for sampling is necessary to perform proper sampling of any hazardous waste. A checklist of items required for field sampling helps to ensure proper preparation. Such a checklist is given in Appendix C. The appendix lists the minimal equipment, accessories, and supplies necessary to sample any type of solid or liquid waste. When the type of waste to be sampled is known beforehand, the list can be narrowed down to the actual pieces of equipment to be used.

When sample analyses are to be performed in the field, such as for pH, flammability, or explosivity, then the necessary apparatus for such tests should also be included in the preparation for sampling.

#### CLEANING AND STORAGE OF SAMPLER

All samplers must be clean before use. Used samplers must be washed with warm detergent solution (i.e., Liquinox or Alconox), rinsed several times with tap water, rinsed with distilled water, drained of excess water, and air dried or dried with a stream of warm, dry air or wiped dry. For samplers that have been used to sample petroleum products and oil residues, it may be necessary first to wipe the samplers with absorbent cloth to eliminate the residues. The equipment is then rinsed with an organic solvent such as petroleum naphtha or trichloroethane, followed by washing with the detergent solution and rinsing with water. A necessary piece of equipment for cleaning the tube of a Coliwasa is a bottle brush that fits tightly the inside diameter of the tube. The brush is connected to a rod of sufficient length to allow for reaching the entire length of the sampler tube. Using this ramrod and fiber-reinforced paper towels, the Coliwasa tube may be quickly cleaned.

Improper cleaning of sampling equipment will cause cross contamination of samples. Such contamination is of particular importance in samples taken for legal or regulatory purposes. Also, contamination becomes important when sampling wastes from different production sources within the same time frame. A detailed study of cross contamination as a function of cleaning procedures has not been carried out. A recommended policy is that if samples are to be taken for legal or regulatory purposes, or if analysis is to be performed on samples expected to contain low-level (low ppm range)

concentrations of hazardous components, that a fresh, unused sampler be used. The Coliwasa in particular was designed to be semidisposable. Parts of the device that become contaminated during sampling (i.e., the tube, the stopper rod, and the stopper mechanism) may be discarded at little expense. In addition, or these parts may later be disassembled, secured, and returned to the laboratory for thorough decontamination and reused.

If the cleaning process has the potential for producing toxic fumes, ensure adequate ventilation. If the washings are hazardous, store them in closed waste containers and dispose of them properly in approved disposal sites. Locations of these sites close to one's area may be obtained by calling the agency in the State responsible for the regulation of hazardous wastes. Store the clean samplers in a clean and protected area. Polyethylene plastic tubes or bags are usually adequate for storing the samplers.

## SECTION 6

### SAMPLING PROCEDURES

#### PURPOSES AND GENERAL CONSIDERATIONS

Sampling of hazardous wastes is conducted for different purposes. In most instances, it is performed to determine compliance with existing regulations promulgated by the different regulatory agencies. In some cases, it is conducted to obtain data for purposes of classifying, treating, recovering, recycling, or determining compatibility characteristics of the wastes. Sampling is also conducted as an important part of research activities.

In general, sampling of hazardous wastes requires the collection of adequate sized, representative samples of the body of wastes. Sampling situations vary widely and therefore no universal sampling procedure can be recommended. Rather, several procedures are outlined for sampling different types of wastes in various states and containers.

These procedures require a plan of action to maximize safety of sampling personnel, minimize sampling time and cost, reduce errors in sampling, and protect the integrity of the samples after sampling. The following steps are essential in this plan of action:

1. Research background information about the waste.
2. Determine what should be sampled.
3. Select the proper sampler.
4. Select the proper sample container and closure.
5. Design an adequate sampling plan that includes the following:
  - a) Choice of the proper sampling point.
  - b) Determination of the number of samples to be taken.
  - c) Determination of the volumes of samples to be taken.
6. Observe proper sampling precautions.
7. Handle samples properly.
8. Identify samples and protect them from tampering.
9. Record all sample information in a field notebook.
10. Fill out chain of custody record.
11. Fill out the sample analysis request sheet.
12. Deliver or ship the samples to the laboratory for analysis.

## BACKGROUND INFORMATION ABOUT THE WASTE

Accurate background information about the waste to be sampled is very important in planning any sampling activity. The information is used to determine the types of protective sampling equipment to be used, sampling precautions to be observed, as well as the types of samplers, sample containers, container closures, and preservatives (when needed) required. Generally, the information about the waste determines the kind of sampling scheme to be used.

Most often, the information about the waste is incomplete. In these instances, as much information as possible must be obtained by examining any documentation pertaining to the wastes, such as the hauler's manifest (Figure 10). When documentation is not available, information may be obtained from the generator, hauler, disposer, or processor. The information obtained is checked for hazardous properties against references such as the Dangerous Properties of Industrial Materials,<sup>10</sup> the Merck Index,<sup>3</sup> the Condensed Chemical Dictionary,<sup>11</sup> Toxic and Hazardous Industrial Chemicals Safety Manual for Handling and Disposal with Toxicity and Hazardous Data,<sup>12</sup> or other chemical references.

## SELECTION OF SAMPLER

Hazardous wastes are usually complex, multiphase mixtures of liquids, semisolids, sludges, or solids.<sup>1</sup> The liquid and semisolid mixtures vary greatly in viscosity, corrosivity, volatility, explosivity, and flammability. The solid wastes can range from powders to granules to big lumps. The wastes are contained in drums, barrels, sacks, bins, vacuum trucks, ponds, and other containers. No single type of sampler can therefore be used to collect representative samples of all types of wastes. Table 3 lists most waste types and the corresponding recommended samplers to be used.

## SELECTION OF SAMPLE CONTAINER, CONTAINER CLOSURE, AND CLOSURE LINING

### Containers

The most important factors to consider when choosing containers for hazardous waste samples are compatibility, resistance to breakage, and volume. Containers must not melt, rupture, or leak as a result of chemical reactions with constituents of waste samples. Thus, it is important to have some idea of the components of the waste. The containers must have adequate wall thickness to withstand handling during sample collection and transport to the laboratory. Containers with wide mouths are desirable to facilitate transfer of samples from samplers to containers. Also, the containers must be large enough to contain the required volume of samplers or the entire volume of a sample contained in samplers.

Plastic and glass containers are generally used for collection and storage of hazardous waste samples. Commonly available plastic containers

are made of high-density or linear polyethylene (LPE), conventional polyethylene, polypropylene, polycarbonate, teflon FEP (fluorinated ethylene propylene), polyvinyl chloride (PVC), or polymethylpentene. Teflon FEP is the most inert plastic, but LPE offers the best combination of chemical resistance and low cost.

Glass containers are relatively inert to most chemicals and can be used to collect and store almost all hazardous waste samples except those that contain strong alkali and hydrofluoric acid. Soda glass bottles are the cheapest and most readily available. Borosilicate such as Pyrex and Corex glass containers are also commercially available, but they are expensive and not always readily obtainable. Glass containers are breakable and much heavier than plastic containers.

**CALIFORNIA LIQUID WASTE HAULER RECORD**  
STATE WATER RESOURCES CONTROL BOARD  
STATE DEPARTMENT OF HEALTH

009-000928

Revised December 1974

<p><b>PRODUCER OF WASTE (Must be filled by producer)</b></p> <p>Name _____ (print or type) _____ CODE NO. _____</p> <p>Pick up Address: _____ (number) _____ (street) _____ (city) _____</p> <p>Telephone Number: _____ P.O. or Contract No.: _____</p> <p>Order Placed By: _____ Date: _____</p> <p>Type of Process which Produced Wastes: _____ CODE NO. _____ (Examples: metal plating, equipment cleaning, oil drilling-wastewater treatment, pickling bath, petroleum refining)</p> <p><b>DESCRIPTION OF WASTE (Must be filled by producer)</b></p> <p>Check type of wastes:</p> <table style="width: 100%;"> <tr> <td>1. <input type="checkbox"/> Acid solution</td> <td>6. <input type="checkbox"/> Tetraethyl lead sludge</td> <td>11. <input type="checkbox"/> Contaminated soil and sand</td> </tr> <tr> <td>2. <input type="checkbox"/> Alkaline solution</td> <td>7. <input type="checkbox"/> Chemical toilet wastes</td> <td>12. <input type="checkbox"/> Cannery waste</td> </tr> <tr> <td>3. <input type="checkbox"/> Pesticides</td> <td>8. <input type="checkbox"/> Tank bottom sediment</td> <td>13. <input type="checkbox"/> Latex waste</td> </tr> <tr> <td>4. <input type="checkbox"/> Paint sludge</td> <td>9. <input type="checkbox"/> Oil</td> <td>14. <input type="checkbox"/> Mud and water</td> </tr> <tr> <td>5. <input type="checkbox"/> Solvent</td> <td>10. <input type="checkbox"/> Drilling mud</td> <td>15. <input type="checkbox"/> Brine</td> </tr> </table> <p><input type="checkbox"/> Other (Specify) _____ CODE NO. _____</p> <p>Components: _____ (Examples: Hydrochloric acid, lime, caustic soda, phenolics, solvents (list), metals (list), organics (list), cyanide)</p> <table style="width: 100%; border-collapse: collapse;"> <thead> <tr> <th></th> <th>Upper</th> <th>Lower</th> <th>%</th> <th>ppm</th> </tr> </thead> <tbody> <tr> <td>1. _____</td> <td style="text-align: center;"> </td> <td style="text-align: center;"> </td> <td style="text-align: center;"> </td> <td style="text-align: center;"> </td> </tr> <tr> <td>2. _____</td> <td style="text-align: center;"> </td> <td style="text-align: center;"> </td> <td style="text-align: center;"> </td> <td style="text-align: center;"> </td> </tr> <tr> <td>3. _____</td> <td style="text-align: center;"> </td> <td style="text-align: center;"> </td> <td style="text-align: center;"> </td> <td style="text-align: center;"> </td> </tr> <tr> <td>4. _____</td> <td style="text-align: center;"> </td> <td style="text-align: center;"> </td> <td style="text-align: center;"> </td> <td style="text-align: center;"> </td> </tr> <tr> <td>5. _____</td> <td style="text-align: center;"> </td> <td style="text-align: center;"> </td> <td style="text-align: center;"> </td> <td style="text-align: center;"> </td> </tr> <tr> <td>6. _____</td> <td style="text-align: center;"> </td> <td style="text-align: center;"> </td> <td style="text-align: center;"> </td> <td style="text-align: center;"> </td> </tr> </tbody> </table> <p><b>Hazardous Properties of Waste:</b> pH _____ <input type="checkbox"/> none <input type="checkbox"/> toxic <input type="checkbox"/> flammable <input type="checkbox"/> corrosive <input type="checkbox"/> explosive</p> <p>Bulk Volume: _____ <input type="checkbox"/> gal <input type="checkbox"/> tons <input type="checkbox"/> barrels (42 gal.) <input type="checkbox"/> other _____ (specify)</p> <p>Containers: _____ (number) <input type="checkbox"/> drums <input type="checkbox"/> cartons <input type="checkbox"/> bags <input type="checkbox"/> other _____ (specify)</p> <p>Physical State: <input type="checkbox"/> solid <input type="checkbox"/> liquid <input type="checkbox"/> sludge <input type="checkbox"/> other _____ (specify)</p> <p>Special Handling Instructions (if any): _____</p> <p>The waste is described to the best of my ability and it was delivered to a licensed liquid waste hauler (if applicable). I certify (or declare) under penalty of perjury that the foregoing is true and correct.</p> <p style="text-align: right;">SIGNATURE OF AUTHORIZED AGENT AND TITLE _____</p>	1. <input type="checkbox"/> Acid solution	6. <input type="checkbox"/> Tetraethyl lead sludge	11. <input type="checkbox"/> Contaminated soil and sand	2. <input type="checkbox"/> Alkaline solution	7. <input type="checkbox"/> Chemical toilet wastes	12. <input type="checkbox"/> Cannery waste	3. <input type="checkbox"/> Pesticides	8. <input type="checkbox"/> Tank bottom sediment	13. <input type="checkbox"/> Latex waste	4. <input type="checkbox"/> Paint sludge	9. <input type="checkbox"/> Oil	14. <input type="checkbox"/> Mud and water	5. <input type="checkbox"/> Solvent	10. <input type="checkbox"/> Drilling mud	15. <input type="checkbox"/> Brine		Upper	Lower	%	ppm	1. _____					2. _____					3. _____					4. _____					5. _____					6. _____					<p><b>HAULER OF WASTE (Must be filled by hauler)</b></p> <p>_____ CODE NO. _____</p> <p>Pick Up: _____ (DATE) _____ Time: _____ GPM _____ GPM</p> <p>State Liquid Waste Hauler's Registration No. (if applicable): _____ 9 _____</p> <p>Job No.: _____ No. of Loads or Trips: _____ Unit No. _____</p> <p>Vehicle: <input type="checkbox"/> vacuum truck _____ barrels, <input type="checkbox"/> flatbed, <input type="checkbox"/> other _____ (specify)</p> <p>The described waste was hauled by me to the disposal facility named below and was accepted. I certify (or declare) under penalty of perjury that the foregoing is true and correct.</p> <p style="text-align: right;">SIGNATURE OF AUTHORIZED AGENT AND TITLE _____</p> <p><b>DISPOSER OF WASTE (Must be filled by disposer)</b></p> <p>Name (print or type): _____ CODE NO. _____</p> <p>Site Address: _____</p> <p>The hauler above delivered the described waste to this disposal facility and it was an acceptable material under the terms of RWQCB requirements, State Department of Health regulations, and local restrictions.</p> <p>Quantity measured at site (if applicable): _____ State fee (if any): _____</p> <p>Handling Method(s): <input type="checkbox"/> recovery <input type="checkbox"/> treatment (specify): _____ (EXAMPLES: INCINERATION, NEUTRALIZATION, PRECIPITATION) CODE NO. _____ <input type="checkbox"/> disposal (specify): <input type="checkbox"/> pond <input type="checkbox"/> spreading <input type="checkbox"/> landfill <input type="checkbox"/> injection well <input type="checkbox"/> other (specify): _____ CODE NO. _____</p> <p>If waste is held for disposal elsewhere specify final location: _____</p> <p>Disposal Date: _____</p> <p>I certify (or declare) under penalty of perjury that the foregoing is true and correct.</p> <p style="text-align: right;">SIGNATURE OF AUTHORIZED AGENT AND TITLE _____</p> <p>The site operator shall submit a legible copy of each completed Record to the State Department of Health with monthly fee reports.</p> <p style="text-align: center;">FOR INFORMATION RELATED TO SPILLS OR OTHER EMERGENCIES INVOLVING HAZARDOUS WASTE OR OTHER MATERIALS CALL (800) 424-9300.</p> <p>D.O.T. Proper Shipping Name _____</p>
1. <input type="checkbox"/> Acid solution	6. <input type="checkbox"/> Tetraethyl lead sludge	11. <input type="checkbox"/> Contaminated soil and sand																																																	
2. <input type="checkbox"/> Alkaline solution	7. <input type="checkbox"/> Chemical toilet wastes	12. <input type="checkbox"/> Cannery waste																																																	
3. <input type="checkbox"/> Pesticides	8. <input type="checkbox"/> Tank bottom sediment	13. <input type="checkbox"/> Latex waste																																																	
4. <input type="checkbox"/> Paint sludge	9. <input type="checkbox"/> Oil	14. <input type="checkbox"/> Mud and water																																																	
5. <input type="checkbox"/> Solvent	10. <input type="checkbox"/> Drilling mud	15. <input type="checkbox"/> Brine																																																	
	Upper	Lower	%	ppm																																															
1. _____																																																			
2. _____																																																			
3. _____																																																			
4. _____																																																			
5. _____																																																			
6. _____																																																			

Figure 10. Example of waste manifest

TABLE 3. SAMPLERS RECOMMENDED FOR VARIOUS TYPES OF WASTE

Waste type	Recommended sampler	Limitations
Liquids, sludges, and slurries in drums, vacuum trucks, barrels, and similar containers	Coliwasa	Not for containers 1.5 m(5 ft ) deep.
	a) Plastic	Not for wastes containing ketones, nitrobenzene, dimethylformamide, mesityl oxide, or tetrahydrofuran <sup>3,4</sup> .
	b) Glass	Not for wastes containing hydrofluoric acid and concentrated alkali solutions.
Liquids and sludges in ponds, pits, or lagoons	Pond	Cannot be used to collect samples beyond 3.5 m(11.5 ft ). Dip and retrieve sampler slowly to avoid bending the tubular aluminum handle.
Powdered or granular solids in bags, drums, barrels, and similar containers	a) Grain sampler	Limited application for sampling moist and sticky solids with a diameter 0.6 cm( $\frac{1}{4}$ in.).
	b) Sampling trier	May incur difficulty in retaining core sample of very dry granular materials during sampling.
Dry wastes in shallow containers and surface soil	Trowel or scoop	Not applicable to sampling deeper than 8 cm(3 in.). Difficult to obtain reproducible mass of samples.
Waste piles	Waste pile sampler	Not applicable to sampling solid wastes with dimensions greater than half the diameter of the sampling tube.
Soil deeper than 8 cm(3 in.)	a) Soil auger	Does not collect undisturbed core sample.
	b) Veihmeyer sampler	Difficult to use on stony, rocky, or very wet soil.
Wastes in storage tanks	Weighted bottle sampler	May be difficult to use on very viscous liquids.

Wide-mouth 1000- and 2000-ml (1 qt- and ½-gal.) glass bottles are recommended for waste samples containing petroleum distillates, chlorinated hydrocarbons, pesticides, and petroleum residues that are mostly incompatible with plastic containers. For all other types of samples, 1000- and 2000-ml (1-qt and ½-gal.) wide-mouth LPE bottles are recommended.

#### Container Closures and Closure Linings

The containers must have tight, screw-type lids. Plastic bottles are usually provided with screw caps made of the same material as the bottles. No cap liners are usually required. Glass containers usually come with glass or rigid plastic screw caps such as Bakelite. The plastic caps are popularly provided with waxed paper liners. Other liner materials are polyethylene, polypropylene, neoprene, and Teflon FEP plastics. For containing hazardous waste samples requiring petroleum distillates, chlorinated hydrocarbons, pesticides, and petroleum residue analyses. Bakelite caps with Teflon liners are recommended to be used with glass bottles. Teflon liners may be purchased from plastic specialty supply houses (e.g., Scientific Specialties Service, Inc., P.O. Box 352, Randallstown, Md. 21133).

Table 4 shows most types of wastes and the corresponding sampling containers and closures recommended.

#### SAMPLING PLAN

The sampling plan should be well formulated before any actual sampling is attempted. The plan must be consistent with the objectives of the sampling. It must include the selected point(s) of sampling and the intended number, volumes, and types (i.e., composite, grab, etc.) of samples to be taken. These requirements are discussed below.

#### POINT OF SAMPLING

A representative sample is crucial to the sampling plan. This sample depends on proper selection of sampling points in the bulk of the waste. Hazardous wastes are usually multiphase mixtures and are contained and stored in containers of different sizes and shapes. No single sampling point can be specified for all types of containers. Table 5 lists most types of containers used for hazardous wastes and the corresponding recommended sampling points.

#### NUMBER OF SAMPLES

The number of samples to be taken primarily depends on the information desired. Table 6 lists the recommended number of samples to be collected consistent with the information sought and the types of wastes to be sampled. In hazardous waste management, the properties and the average concentrations of the hazardous components are usually desired. In this

TABLE 4. SAMPLE CONTAINERS AND CLOSURES RECOMMENDED FOR

## VARIOUS TYPES OF WASTE

Waste type item	Recommended container	Recommended closure
Oil wastes except pesticides, HC, chlorinated HC, and photosensitive wastes	Linear polyethylene (LPE) bottles, <sup>a</sup> 1000- and 2000-ml (1-qt. and ½-gal.), wide mouth	LPE caps
Pesticides, HC, and chlorinated HC	Glass bottles, <sup>b</sup> wide-mouth, 1000- and 2000-ml (1-qt. and ½-gal.).	Bakelite caps with Teflon liner <sup>c</sup>
Photosensitive wastes	Amber LPE or brown glass <sup>d</sup> bottles, wide-mouth, 1000- and 200-ml (1-qt. and ½-gal.)	LPE caps for the LPE bottles; Bakelite caps with Teflon liner for the glass bottles

<sup>a</sup>Nalgene, Cat. Nos. 2104-0032 and 2120-0005, or equivalent.

<sup>b</sup>Scientific Products, Cat. Nos. 87519-32 and B7519-64, or equivalent.

<sup>c</sup>Available from Scientific Specialities, P.O. Box 352, Randallstown, Md.

<sup>d</sup>Scientific Products, Cat. Nos. B7528-050 and 7528-2L, or equivalent.

TABLE 5. SAMPLING POINTS RECOMMENDED FOR MOST WASTE CONTAINERS

Container type	Sampling point
Drum, bung on one end	Withdraw sample through the bung opening.
Drum, bung on side	Lay drum on side with bung up. Withdraw sample through the bung opening.
Barrel, fiberdrum, buckets, sacks, bags	Withdraw samples through the top of barrels, fiberdrums, buckets, and similar containers. Withdraw samples through fill openings of bags and sacks. Withdraw samples through the center of the containers and to different points diagonally opposite the point of entry.
Vacuum truck and similar containers	Withdraw sample through open hatch. Sample all other hatches.
Pond, pit, lagoons	Divide surface area into an imaginary grid. <sup>a</sup> Take three samples, if possible: one sample near the surface, one sample at mid-depth or at center, and one sample at the bottom. Repeat the sampling at each grid over the entire pond or site.
Waste pile	Withdraw samples through at least three different points near the top of pile to points diagonally opposite the point of entry.
Storage tank	Sample from the top through the sampling hole.
Soil	Divide the surface area into an imaginary grid. <sup>a</sup> Sample each grid.

<sup>a</sup>The number of grid is determined by the desired number of samples to be collected, which when combined should give a representative sample of the wastes.

respect, collecting one representative sample of a given waste is usually adequate. This sample can either be collected from a single sampling point with a composite sampler, or several samples can be collected from various sampling points and combine into one composite sample.

When gathering evidence for possible legal actions, multiple samples of a waste are usually collected. Three identical samples are desirable: one sample is given to the company or organization responsible for the waste, the second sample is submitted to the laboratory for analysis, and the third sample is kept in storage for possible use as a referee sample. Subdividing a waste sample is not recommended unless it is homogeneous.

#### VOLUME OF SAMPLES

Sufficient volume of a sample, representative of the main body of the waste, must be collected. This sample must be adequate in size for all needs, including laboratory analysis, splitting with other organizations involved, etc. In collecting liquid waste samples in drums, vacuum trucks, or similar containers, the volume collected in the Coliwasa usually determines the volume of the sample. This volume can range from 200 to 1800 ( $\frac{1}{2}$  pt. to 1.9 qt.). In most cases, 1000 ml (1 qt.) of a sample is usually sufficient. Hazardous wastes usually contain high concentrations of the hazardous components, and only a small aliquot of the sample is used for analysis.

#### SAMPLING PRECAUTIONS AND PROTECTIVE GEAR

Proper safety precautions must always be observed when sampling hazardous wastes. In all cases, a person collecting a sample must be aware that the waste can be a strong sensitizer and can be corrosive, flammable, explosive, toxic, and capable of releasing extremely poisonous gases.<sup>13</sup> The background information obtained about the waste should be helpful in deciding the extent of sampling safety precautions to be observed and in choosing protective equipment to be used.

For full protection, the person collecting the sample must use a self-contained breathing apparatus, protective clothing, hard hat, neoprene rubber gloves, goggles, and rubber boots.

A self-contained breathing apparatus consists of an air-tight face mask and a supply of air in a pressure tank equipped with a pressure regulator. Protective clothing consists of long-sleeved neoprene rubber coat and pants, or long-sleeved coverall and oil-and-acid proof apron. In hot weather, the coverall-apron combination might be preferred. Table 7 lists the uses and commercial availability of respiratory protective equipment. All equipment except the respirator must be properly washed and cleaned between uses (see Section 5).

TABLE 6. NUMBER OF SAMPLES TO BE COLLECTED

Case No.	Information desired	Waste type	Container type	Number of samples to be collected
1	Average concentration	Liquid	Drum, vacuum truck, and similar containers	1 Collected with Coliwasa
2	Average concentration	Liquid	Pond, pit, lagoon	1 Composite sample of several samples collected at different sampling points or levels
3	Average concentration	Solid (powder or granular)	Bag, drum, bin sack	Same as Case #2
4	Average concentration	Waste pile	--	Same as Case #2
5	Average concentration	Soil	--	1 Composite sample of several samples collected at different sampling areas
6	Concentration range	Liquid	Drum, vacuum truck, storage tank	3 to 10 separate samples, each from a different depth of the liquid
7	Concentration range	Liquid	Ponds, pit, lagoon	3 to 20 separate samples from different sampling points and depths
8	Concentration range	Solid (powder or granular)	Bag, drum, bin	3 to 5 samples from different sampling points
9	Concentration range	Waste pile	--	Same as Case #8
10	Concentration range	Soil	--	3 to 20 separate samples from different sampling areas
11	Average concentration for legal evidence	All types	All containers	3 Identical samples or 1 composite sample divided into 3 identical samples if homogeneous
12	Average concentration	Liquid	Storage tank	Same as Case #2
13	Average concentration	Liquid	Storage tank	Same as Case #6

TABLE 7. RESPIRATORY PROTECTIVE DEVICES RECOMMENDED  
FOR VARIOUS HAZARDS

Type of hazard	Recommended respiratory device
Oxygen deficiency	Self-contained breathing apparatus, hose mask with blower
Gaseous contaminant immediately dangerous to life	Self-contained breathing apparatus, hose mask with blower, gas mask
Gaseous contaminant not immediately dangerous to life	Air-line respirator, hose mask without blower, chemical-cartridge respirator
Particulate contaminant	Dust, mist, or fume respirator, air-line respirator, abrasive-blasting respirator
Combination of gaseous and particulate contaminants immediately dangerous to life	Self-contained breathing apparatus, hose mask with blower, gas mask with special filter
Combination of gaseous and particulate contaminants not immediately dangerous to life	Air-line respirator, hose mask without blower, chemical-cartridge respirator with special filter

<sup>a</sup>Source: Reference 14.

The self-contained breathing apparatus may not be required in all sampling situations. In some cases, gas masks or chemical cartridge-type respirators with filters will suffice. Table 7 may be used to select the proper protective respiratory device.

For added protection in sampling, a second person with a radio-telephone and first-aid kit must be present to render any necessary help or call for assistance.

#### SAMPLING PROCEDURES

The following procedures are recommended for sampling different types of hazardous wastes in various containers.

##### Sampling a Drum

Drums containing liquid wastes can be under pressure or vacuum. A bulging drum usually indicates that it is under high pressure and should not be sampled until the pressure can be safely relieved. A heavily corroded or rusted drum can readily rupture and spill its contents when disturbed; it should only be sampled with extreme caution. Opening the bung of a drum can produce a spark that might detonate an explosive gas mixture in the drum. This situation is difficult to predict and must be taken into consideration every time a drum is opened. The need for full protective sampling equipment cannot be overemphasized when sampling a drum.

1. Position the drum so that the bung is up (drums with the bung on the end should be positioned upright; drums with bungs on the side should be laid on its side, with the bungs up).
2. Allow the contents of the drum to settle.
3. Slowly loosen the bung with a bung wrench, allowing any gas pressure to release.
4. Remove the bung and collect a sample through the bung hole with a Coliwasa, as directed in Section 4.
5. When there is more than one drum of waste at a site, segregate and sample the drums according to waste types, using a table of random numbers as outlined in Appendix D.

##### Sampling a Vacuum Truck

Sampling a vacuum truck requires the person collecting the sample to climb onto the truck and walk along a narrow catwalk. In some trucks, it requires climbing access rungs to the tank hatch. These situations present accessibility problems to the sample collector, who most usually

wear full protective sampling gear. Preferably, two persons should perform the sampling: One person should do the actual sampling and the other should hand the sampling device, stand ready with the sample container, and help deal with any problems. The sample collector should position himself to collect samples only after the truck driver has opened the tank hatch. The tank is usually under pressure or vacuum. The driver should open the hatch slowly to release pressure or to break the vacuum.

1. Let the truck driver open the tank hatch.
2. Using protective sampling gear, assume a stable stance on the tank catwalk or access rung to the hatch.
3. Collect a sample through the hatch opening with a Coliwasa, as directed in Section 4.
4. If the tank truck is not horizontal, take one additional sample each from the rear and front clean out hatches and combine all three samples in one sample container.
5. When necessary, carefully take sediment sample from the tank through the drain spigot.

#### Sampling a Barrel, Fiberdrum, Can, Bags, or Sacks Containing Powder or Granular Waste

The proper protective respirator (see Table 7), in addition to the other protective gear, must be worn when sampling dry powdered or granular wastes in these containers. These wastes tend to generate airborne particles when the containers are disturbed. The containers must be opened slowly. The barrels, fiberdrums, and cans must be positioned upright. If possible, sample sacks or bags in the position you find them, since standing them upright might rupture the bags or sacks.

1. Collect a composite sample from the container with a grain sampler or sampler trier, as directed in Section 4.
2. When there is more than one container of waste at a site, segregate and sample the containers according to a table of random numbers, as outlined in Appendix D.

#### Sampling a Pond

Storage or evaporation ponds for hazardous wastes vary greatly in size from a few to a hundred meters. It is difficult to collect representative samples from the large ponds without incurring huge expense and assuming excessive risks. Any samples desired beyond 3.5m (11½ ft) from the bank may require the use of a boat, which is very risky, or the use of a crane or a helicopter, which is very expensive. The

information sought must be weighed against the risk and expense of collecting the samples. The pond sampler described in Section 4 can be used to collect samples as far as 3.5 m (11½ ft.) from the bank.

1. Collect a composite sample with pond sampler, as directed in Section 4.

#### Sampling Soil

The techniques of soil sampling are numerous. The procedures outlined below are adopted from ASTM methods.<sup>15</sup> The procedures are consistent with the hazardous waste management objective of collecting soil samples which is usually to determine the amount of hazardous material deposited on a particular area of land or to determine the leaching rate of the material and/or determine the residue level on the soil. Elaborate statistically designed patterns have been designed for sampling soils. If one of these patterns is to be used, a good statistics book may have to be consulted. In the following procedures, soil samples are taken in a grid pattern over the entire site to ensure a uniform coverage.

1. Divide the area into an imaginary grid (see Table 5).
2. Sample each grid and combine the samples into one.
3. To sample up to 8 cm (3 in.) deep, collect samples with a scoop, as directed in Section 4.
4. To sample beyond 8 cm (3 in.) deep, collect samples with a soil auger or Veihmeyer soil sampler, as directed in Section 4.

#### Sampling a Waste Pile

Waste piles can range from small heaps to a large aggregates of wastes. The wastes are predominantly solid and can be a mixture of powders, granules, and chunks as large as or greater than 2.54 cm (1 in.) average diameter. A number of core samples have to be taken at different angles and composited to obtain a sample that, on analysis, will give average values for the hazardous components in the waste pile.

1. Determine the sampling points (see Table 5).
2. Collect a composite sample with a waste pile sampler according to the directions in Section 4.

#### Sampling a Storage Tank

The collection of liquid samples in storage tanks is extremely discussed in the ASTM methods. The procedure used here is adopted from one of those methods.<sup>16</sup>

Sampling a storage tank requires a great deal of manual dexterity. Usually it requires climbing to the top of the tank through a narrow vertical or spiral stairway while wearing protective sampling equipment and carry sampling paraphernalia. At least two persons must always perform the sampling: One should collect the actual samples and the other should stand back, usually at the head of the stairway, and observe, ready to assist or call for help. The sample collectors must be accompanied by a representative of the company, who must open the sampling hole, usually on the tank roof.

1. Collect one sample each from the upper, middle, and lower sections of the tank contents with a weighted bottle sampler, as outlined in Section 4.
2. Combine the samples one container and submit it as a composite sample.

#### SAMPLE HANDLING

After a sample is transferred into the proper sample container, the container must be tightly capped as quickly as possible to prevent the loss of volatile components and to exclude possible oxidation from the air.

The use of a preservative or additive is not recommended. However, if only one or two components of a waste are of interest, and if these components are known to rapidly degrade or deteriorate chemically or bio-chemically, the sample may be refrigerated at 4 to 6°C. (39.2 to 42.8°F.) or treated with preservatives according to Section 8.

To split or withdraw an aliquot of a sample, considerable mixing, homogenization, or quartering is required to ensure that representative or identical portions are obtained. When transferring a sample aliquot, open the container as briefly as possible.

#### IDENTIFICATION OF SAMPLE

Each sample must be labeled and sealed properly immediately after collection.

##### Sample Labels

Sample labels (Figure 11) are necessary to prevent misidentification of samples. Gummed paper labels or tags are adequate. The label must include at least the following information:

Name of collector.

Date and time of collection.

Place of collection.

Collector's sample number, which uniquely identifies the sample.

---

**OFFICIAL SAMPLE LABEL**

Collector \_\_\_\_\_ Collector's Sample No. \_\_\_\_\_

Place of Collection \_\_\_\_\_

\_\_\_\_\_

Date Sampled \_\_\_\_\_ Time Sampled \_\_\_\_\_

Field Information \_\_\_\_\_

\_\_\_\_\_

---

Figure 11. Example of official sample label.

---

**OFFICIAL SAMPLE SEAL**

State of California	Public Health Division
Department of Health Services	Hazardous Materials Laboratory

Collected by \_\_\_\_\_ Collector's Sample No. \_\_\_\_\_

(signature)

Date Collected \_\_\_\_\_ Time Collected \_\_\_\_\_

Place Collected \_\_\_\_\_

\_\_\_\_\_

---

Figure 12. Example of official sample seal

## Sample Seals

Sample seals are used to preserve the integrity of the sample from the time it is collected until it is opened in the laboratory. Gummed paper seals can be used as official sample seals. The paper seal must carry information such as:

Collector's name

Date and time of sampling

Collector's sample number. (This number must be identical with the number on the sample label).

The seal must be attached in such a way that it is necessary to break it in order to open the sample container. An example of a sample seal is shown in Figure 12.

## FIELD LOG BOOK

All information pertinent to a field survey and/or sampling must be recorded in a log book. This must be a bound book, preferably with consecutively numbered pages that are 21.6 by 27.9 cm (8½ by 11 in.). Entries in the log book must include at least the following:

Purpose of sampling (e.g., surveillance, etc.)

Location of sampling (e.g., hauler, disposal site, etc.) and address

Name and address of field contact

Producer of waste and address

Type of process (if known) producing waste

Type of waste (e.g., sludge, wastewater, etc.)

Declared waste components and concentrations

Number and volume of sample taken

Description of sampling point

Date and time of collection

Collector's sample identification number(s)

Sample distribution (e.g., laboratory, hauler, etc.)

References such as maps or photographs of the sampling site

Field observations

Any field measurements made such as pH, flammability, explosivity, etc.

Sampling situations vary widely. No general rule can be given as to the extent of information that must be entered in the log book. A good

rule, however, is to record sufficient information so that someone can reconstruct the sampling situation without reliance on the collector's memory.

The log book must be protected and kept in a safe place.

#### CHAIN OF CUSTODY RECORD

To establish the documentation necessary to trace sample possession from the time of collection, a chain of custody record must be filled out and accompany every sample. This record becomes especially important when the sample is to be introduced as evidence in a court litigation. An example of a chain of custody record is illustrated in Figure 13.

The record must contain the following minimum information:

Collector's sample number

Signature of collector

Date and time of collection

Place and address of collection

Waste type

Signatures of persons involved in the chain of possession

Inclusive dates of possession

#### SAMPLE ANALYSIS REQUEST SHEET

The sample analysis request sheet (Figure 14) is intended to accompany the sample on delivery to the laboratory. The field portion of this form must be completed by the person collecting the sample and should include most of the pertinent information noted in the log book. The laboratory portion of this form is intended to be completed by laboratory personnel and to include:

Name of person receiving the sample

Laboratory sample number

Date of sample receipt

Sample allocation

Analyses to be performed

#### SAMPLE DELIVERY TO THE LABORATORY

Preferably, the sample must be delivered in person to the laboratory for analysis as soon as practicable--usually the same day as the sampling. Consult Section 8 when sample preservation is required. The sample must

CHAIN OF CUSTODY RECORD  
Hazardous Materials

Location of Sampling:  Producer  Hauler  Disposal Site  
 Other: \_\_\_\_\_

Company's Name \_\_\_\_\_ Telephone (\_\_\_\_) \_\_\_\_\_

Address \_\_\_\_\_  
number street city state zip

Collector's Name \_\_\_\_\_ Telephone (\_\_\_\_) \_\_\_\_\_

signature  
Date Sampled \_\_\_\_\_ Time Sampled \_\_\_\_\_ hours

Type of Process Producing Waste \_\_\_\_\_

Waste Type Code \_\_\_\_\_ Other \_\_\_\_\_

Field Information \_\_\_\_\_  
\_\_\_\_\_  
\_\_\_\_\_

Sample Allocation:

1. \_\_\_\_\_  
name of organization
2. \_\_\_\_\_  
name of organization
3. \_\_\_\_\_  
name of organization

Chain of Possession

- |    |           |       |                 |
|----|-----------|-------|-----------------|
| 1. | _____     | _____ | _____           |
|    | signature | title | inclusive dates |
| 2. | _____     | _____ | _____           |
|    | signature | title | inclusive dates |
| 3. | _____     | _____ | _____           |
|    | signature | title | inclusive dates |

Figure 13. Example of chain of custody record

PRIORITY \_\_\_\_\_  
(explain) \_\_\_\_\_  
\_\_\_\_\_  
\_\_\_\_\_

California Department of Health Services  
Hazardous Materials Laboratory

### HAZARDOUS MATERIALS SAMPLE ANALYSIS REQUEST

PART I: FIELD SECTION

Collector \_\_\_\_\_ Date Sampled \_\_\_\_\_ Time \_\_\_\_\_ hours

Location of Sampling \_\_\_\_\_  
name of company, disposal site, etc.

Address \_\_\_\_\_

Telephone ( ) \_\_\_\_\_ number street city state zip  
Company Contact \_\_\_\_\_

<u>HML NO.</u> <u>(Lab only)</u>	<u>COLLECTOR'S</u> <u>SAMPLE NO.</u>	<u>TYPE OF</u> <u>SAMPLE*</u>	<u>FIELD INFORMATION**</u>
_____	_____	_____	_____
_____	_____	_____	_____
_____	_____	_____	_____
_____	_____	_____	_____
_____	_____	_____	_____

Analysis Requested \_\_\_\_\_  
\_\_\_\_\_  
\_\_\_\_\_

Special Handling and/or Storage \_\_\_\_\_  
\_\_\_\_\_

PART II: LABORATORY SECTION

Received by \_\_\_\_\_ Title \_\_\_\_\_ Date \_\_\_\_\_  
Sample Allocation: \_\_HML \_\_LBL \_\_LABEL \_\_SRL Date \_\_\_\_\_  
Analysis Required \_\_\_\_\_  
\_\_\_\_\_  
\_\_\_\_\_

\*Indicate whether sample is sludge, soil, etc.;\*\*Use back of page for additional information.

Figure 14. Example of hazardous waste sample analysis request sheet

be accompanied by the chain of custody record and by a sample analysis request sheet (Figure 14). The sample must be delivered to the person in the laboratory authorized to receive samples (often referred to as the sample custodian).

#### SHIPPING OF SAMPLES

When a sample is shipped to the laboratory, it must be packaged in a proper shipping container to avoid leakage and/or breakage. A cardboard box that will provide at least 10 cm(4 in.) of tight packing around the sample container must be used. Acceptable packing materials include sawdust, crumpled newspapers, vermiculite, polyurethane chips, etc. Other samples that require refrigeration must be packed with reusable plastic packs or cans of frozen freezing gels in molded polyurethane boxes with sturdy fiberboard protective case. The boxes must be taped closed with masking tape or fiber plastic tape.

All packages must be accompanied by a sample analysis sheet and chain of custody record. Complete address of the sender and the receiving laboratory must legibly appear on each package. When sent by mail, register the package with return receipt requested. When sent by common carrier, obtain a copy of the bill of lading. Post office receipts and bill of lading copies may be used as part of the chain of custody documentation.<sup>17</sup>

## SECTION 7

### RECEIPT AND LOGGING OF SAMPLE

Field samples are delivered to the laboratory either personally or through a public carrier. In the laboratory, a sample custodian should be assigned to receive the samples. Upon receipt of a sample, the custodian should inspect the condition of the sample and the sample seal, reconcile the information on the sample label and seal against that on the chain of custody record, assign a laboratory number, log in the sample in the laboratory log book, and store the sample in a secured sample storage room or cabinet until assigned to an analyst for analysis.

#### SAMPLE INSPECTION

The sample custodian should inspect the sample for any leakage from the container. A leaky container containing multiphase sample should not be accepted for analysis. This sample will no longer be a representative sample. If the sample is contained in a plastic bottle and the walls show any bulging or collapsing, the custodian should note that the sample is under pressure or releasing gases, respectively. A sample under pressure should be treated with caution. It can be explosive or release extremely poisonous gases. The custodian should examine whether the sample seal is intact or broken, since broken seal may mean sample tampering and would make analysis results inadmissible in court as evidence. Discrepancies between the information on the sample label and seal and that on the chain of custody record and the sample analysis request sheet should be resolved before the sample is assigned for analysis. This effort might require communication with the sample collector. Results of the inspection should be noted on the sample analysis request sheet and on the laboratory sample log book.

#### ASSIGNMENT OF LABORATORY NUMBER

Incoming samples usually carry the inspector's or collector's identification numbers. To further identify these samples, the laboratory should assign its own identification numbers, which normally are given consecutively. Each sample should be marked with the assigned laboratory number. This number is correspondingly recorded on a laboratory sample log book along with the information describing the sample. The sample information is copied from the sample analysis request sheet and cross-checked against that on the sample label.

## ASSIGNMENT OF SAMPLE FOR ANALYSIS

In most cases, the laboratory supervisor assigns the sample for analysis. The supervisor should review the information on the sample analysis request sheet, which now includes inspection notes recorded by the laboratory sample custodian. The supervisor should then decide what analyses are to be performed. The sample may have to be split with other laboratories to obtain the necessary information about the sample. The supervisor should decide on the sample allocation and delineate the types of analyses to be performed on each allocation. In his own laboratory, the supervisor should assign the sample analysis to at least one chemist, who is to be responsible for the care and custody of the sample once it is handed to him. He should be prepared to testify that the sample was in his possession or secured in the laboratory at all times from the moment it was received from the custodian until the analyses were performed.

The receiving chemist should record in his laboratory notebook the identifying information about the sample, the date of receipt, and other pertinent information. This record should also include the subsequent analytical data and calculations.

## SECTION 8

### PRESERVATION AND STORAGE OF SAMPLES

Ideally, hazardous waste samples should be analyzed immediately after collection for maximum reliability of the analytical results. Hazardous wastes are such complex mixtures that it is difficult to exactly predict the physical, biological, and chemical changes that occur in the samples with time. After collection of samples, pH may change significantly in a matter of minutes; sulfides and cyanides may be oxidized or evolve as gases; and hexavalent chromium may slowly be reduced to the trivalent state. Certain cations may be partly lost as a result of adsorption to the walls of the sample containers. Growth of microorganisms may also cause changes to certain constituents of the sample. Volatile compounds may be rapidly lost.

In a number of cases, the above changes may be slowed down or prevented by refrigeration at 4 to 6°C, or by the addition of preservatives. However, these treatments mostly apply to one or two components or properties. Refrigeration may deter the evolution of volatile components and acid gases such as hydrogen sulfides and hydrogen cyanides, but it also introduces the uncertainty that some salts may precipitate at lower temperature. On warming to room temperature for analysis, the precipitates may not redissolve, thus incurring error in determining the actual concentrations of dissolved sample constituents. Addition of preservatives may retard biochemical changes, whereas other additives may convert some constituents to stable hydroxides, salts, or compounds. Unknown in these treatments, however, is the possible conversion of other compounds to other forms (such as the products of nitration, sulfonation, oxidation, etc., of organic components). In subsequent analyses, the results may not reflect the original identity of the components.

Thus, both advantages and disadvantages are associated with the refrigeration and/or addition of preservatives or additives to waste samples. These methods of preservation or stabilization are not recommended for hazardous waste samples unless only one or two components or properties are to be analyzed.

Standard methods books <sup>18,19</sup> have compilations of useful preservatives for various constituents. Table 8 is excerpted from these lists and shows only the preservation methods that may be used for hazardous wastes.

TABLE 8. METHODS OF PRESERVATION FOR HAZARDOUS WASTES

Waste constituent to be preserved	Preservation method	Storage time
Acidity	Cool to 4° C	24 hr
Alkalinity	Cool to 4° C	24 hr
Ammonia	Add 1 ml conc. H <sub>2</sub> SO <sub>4</sub> /ℓ	24 hr
Arsenic	Add 6 ml conc. HNO <sub>3</sub> /ℓ	6 months
Chlorine	Cool to 4° C	24 hr
Chromium (VI)	Add 6 ml conc. H <sub>2</sub> SO <sub>4</sub> /ℓ	24 hr
Cyanides	Add 2.5 ml of 50% NaOH/ℓ ; cool to 4° C	24 hr
Fluoride	Cool to 4° C	7 days
Metals:		
1) dissolved	Filter on site; add 5 ml conc. HNO <sub>3</sub> /ℓ	6 months
2) suspended	Filter on site	6 months
3) Total	Add 5 ml conc. HNO <sub>3</sub> /ℓ	6 months
Mercury		
1) dissolved	Filter; add 5 ml conc. HNO <sub>3</sub> /ℓ	38 days
2) Total	Add 5 ml conc. HNO <sub>3</sub> /ℓ	38 days
pH	Determine on site; cool to 4° C	6 hr
Phenolics	Add H <sub>3</sub> PO <sub>4</sub> to pH 4 and 1 g. CuSO <sub>4</sub> /ℓ ; refrigerate at 4° C	24 hr
Residue, volatile	Cool to 4° C	7 days
Selenium	Add 5 ml conc. HNO <sub>3</sub> /ℓ	6 months
Specific conductance	Cool to 4° C	24 hr
Sulfide	Add 2 ml of 2N Zn(AC) <sub>2</sub> /ℓ	24 hr
Sulfide	Cool to 4° C	24 hr
Zinc	Add 4 ml conc. HCl/ℓ	--

<sup>a</sup>Source: References<sup>18,19, and 20</sup>

## REFERENCES

1. Stephens, R. D. 1976. Hazardous Sampling; Residual Management by Land Disposal. Proceedings of the Hazardous Waste Research Symposium, University of Arizona, Tucson, Ariz.
2. Eichenberger, B., J. R. Edwards, K. Y. Chen, and R. D. Stephens. 1977. A Case Study of Hazardous Wastes Input Into Class I Landfills. U.S. Environmental Protection Agency, Cincinnati, Ohio.
3. Merck Index, An Encyclopedia of Chemicals and Drugs. 1968. 9th Ed. Merck & Co., Rahway.
4. Chemical Resistance of Excelon R-4000. 1977. Thermoplastic Process, Inc., Stirling, N.J.
5. Sampling Procedure for Animal Feed. Official Methods of Analysis of the Association of Official Analytical Chemists. 1975. 12th Ed. Washington, D.C., p. 129.
6. Guidelines on Sampling and Statistical Methodologies for Ambient Pesticide Monitoring. 1974. Federal Working Group on Pest Management, U.S. Environmental Protection Agency, Washington, D.C., p. III-5.
7. Veihmeyer, F. J. 1929. An Improved Soil-Sampling Tube. Soil Science 27(2): 147-152.
8. American Society for Testing and Materials. 1975. ASTM D270. ASTM Standards. The Society, Philadelphia, Pa.
9. American Society for Testing and Materials. 1973. ASTM E 300. ASTM Standards. The Society, Philadelphia, Pa.
10. Sax, I. N. 1968. Dangerous Properties of Industrial Materials. 3rd Ed. Van Nostrand Reinhold Co. New York, N.Y.
11. Condensed Chemical Dictionary. 1977. 8th Ed. Van Nostrand Reinhold Co., New York, N.Y.
12. Toxic and Hazardous Industrial Chemicals Safety Manual for Handling and Disposal With Toxicity and Hazardous Data. 1976. International Technical Information Institute, Tokyo, Japan.
13. Dunlap, J. 1972. Industrial Waste Law (AB 596), State of California.

14. Bureau of Labor Standards. Respiratory Protective Equipment. Bulletin 226. Safety in Industry; Environmental and Chemical Hazards, No. 3. U.S. Department of Labor, Washington, D.C.
15. American Society for Testing and Materials. ASTM D1452, D1586 and D3550. ASTM Standards. The Society, Philadelphia, Pa.
16. American Society for Testing and Materials. ASTM D270 and E 300 ASTM Standards. The Society, Philadelphia, Pa.
17. Compliance Monitoring Procedures. 1974. EPA 330/1-74-/002. U.S. Environmental Protection Agency, Denver, Colo.
18. Manual of Methods for Chemical Analysis of Water and Wastewater. 1974. EPA-625/6-74-003. U.S. Environmental Protection Agency, Washington, D.C.
19. Standard Methods for Examination of Water and Wastewater. 1975. 14th Ed. American Public Health Association, New York, N.Y.
20. Collection, Storage, Transportation, and Pretreatment of Water and Wastewater Samples. 1971. California Department of Health Services, Berkeley, Ca.

## APPENDICES

### APPENDIX A. DEVELOPMENT OF THE COMPOSITE LIQUID WASTE SAMPLER (COLIWASA)

Early in the development of the California waste management program, the needs were recognized for accurate information about waste composition and adequate equipment and procedures for sampling and analysis.

In 1975, the California Department of Health Services engaged in a cooperative study with the University of Southern California (Environmental Engineering Department) under U.S. Environmental Protection Agency's sponsorship to collect and analyze a large number of hazardous waste samples at a number of Class I disposal sites in Los Angeles County. In the preparation of this study, the Department of Health Services personnel designed and constructed a simple tube sampler suitable for use in liquid and sludge wastes. The objective of the sampler design was to obtain samples representative of complex, heterogeneous wastes contained in vacuum trucks and drums. In preliminary testing, the prototype design shown in Figure A-1 appeared to give good representative samples. At this time, the sampling device was named the composite liquid waste sampler, or Coliwasa for short.

#### Requirements for Hazardous Waste Sampling Procedures and Equipment

Approximately 24 of these devices were constructed for use in the Los Angeles County sampling program. During a 2-week period in 1975, 400 samples of hazardous wastes were taken from vacuum trucks and drums. The wastes represented an extremely wide variety of chemical compositions and physical characteristics. The experience given by this sampling program emphasized the following important requirements of hazardous waste sampling procedures and equipment:

- 1) Sampling equipment must be of simple design to facilitate easy cleaning or to allow discard if necessary to prevent sample cross contamination. Many wastes, because of their chemical composition and/or physical nature, so fouled sampling equipment that it required discarding or extensive cleaning. Extensive cleaning produces a significant volume of cleaning waste that must be properly disposed. Equipment that has complicated valves, levers, and other fittings would never survive many hazardous wastes.
- 2) Equipment must be light weight and leak proof. Sampling personnel are required to climb and move about on tank trucks and other dangerous areas while holding sampling equipment. Once the sampler is filled with its

charge of hazardous waste, it must not discharge until properly inside a sample receptacle. Thus, a positive locking mechanism is needed.

- 3) Several types of sampling equipment must be available, for no one design or material meets all hazardous waste sampling requirements.
- 4) Sampling requires a minimum of two persons equipped with the proper and complete complement of safety equipment. Even at a well-run waste disposal site using an approved manifest system, surprises occur. A waste sample collector never knows for sure what he will find when a vacuum truck or barrel is opened.

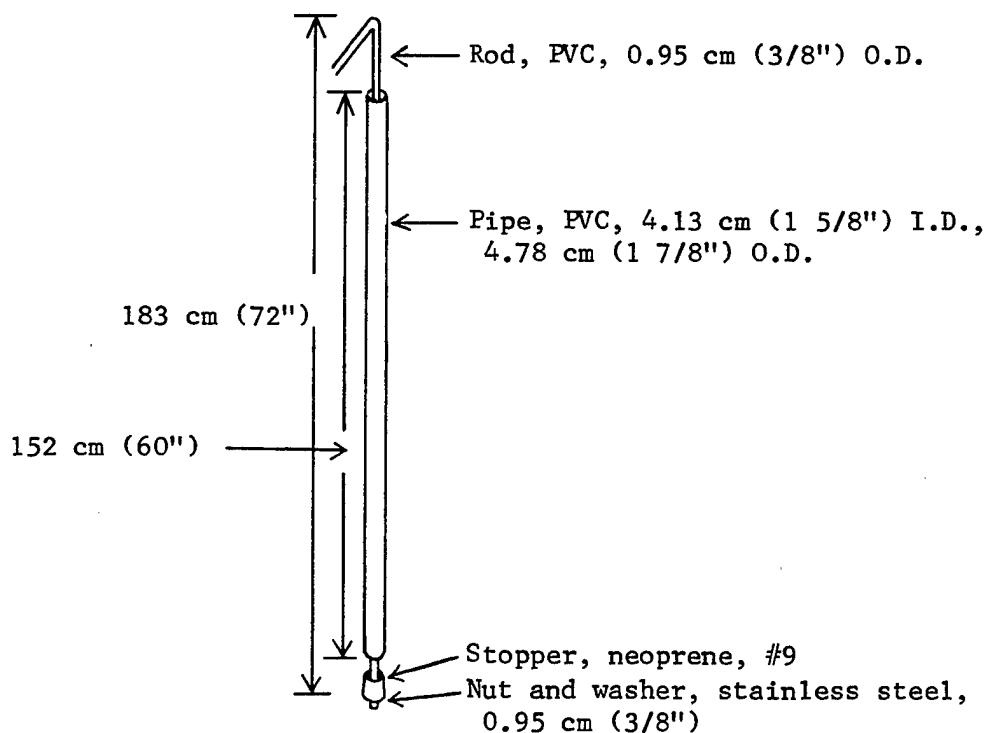

Figure 1. Coliwasa, Model 1.

### Sampler Selection

A review of the literature was conducted to investigate the availability of commercial equipment that would better suit the sampling requirements than the Coliwasa. The guidelines used in the selections were commercial availability, cost, simplicity in design, chemical inertness, and adaptability for use in composite sampling of liquid hazardous wastes.

Preliminary tests were performed on a number of candidate liquid samplers. The tests included physical inspections of the sampling mechanisms for ease of operation and applicability. Water was the initial test liquid. The test water was placed in a fabricated tank made out of a

122-cm(4-ft) tall by 15.2-cm(6-in.) I.D. glass cylinder. Each sampler under test was lowered slowly into the tank to determine whether the check valve or closing device or sampling orifice would allow the sample to flow in the sampler. The sampler was then withdrawn and tested for leakage and ease of transfer of the collected sample.

None of the commercially available samplers was found to be satisfactory. The Coliwasa designed by the Department of Health Services appeared to be the most promising.

#### First Coliwasa Model

The early design of the Coliwasa (Model 1; Figure A-1) consisted of 1.52-m(5-ft.) by 4.13-cm(1 5/8-in.) I.D., opaque PVC pipe as the sampling tube and a neoprene stopper attached to one end of a 0.95-cm(3/8-in.) O.D. PVC rod as the closing mechanism. To collect a sample with this sampler, the stopper is pushed out about 5 cm(2 in.) from the bottom end of the sampling tube. Then the sampler is lowered straight down through the body of liquid waste to be sampled to the bottom of the waste container. The liquid in the tube is trapped by plugging the bottom of the tube with the stopper by pulling up the stopper rod with one hand and holding the tube with the other hand.

This early design of the Coliwasa, albeit functional, was deficient in a number of aspects. First, it was difficult to put the sampler in the close position. The stopper did not easily line up with the bottom opening of the sampling tube. Several manipulations of the stopper rod were usually required to effect closure. This difficulty tended to disturb the bottom layer of the waste being sampled and undoubtedly contributed to the collection of nonrepresentative samples.

Second, the sampler was not equipped with a mechanism that positively and independently locked it closed. Closure was maintained by using one hand to hold the sampling tube and the other hand to maintain a constant upward pressure on the upper end of the stopper rod to keep the stopper tightly seated against the bottom opening of the sampler. In some sampling instances, this method of closure was not always practical. When sampling waste containers as deep as the length of the sampler, the operator could not withdraw the sampler without freeing the hand that maintains the closing pressure on the stopper rod. Thus, the snug contact between the neoprene stopper and the inner opening of the sampling tube was the only force that locked the sampler closed. The weight of the sample contained in the sampling tube has in some cases pushed out the stopper, resulting in lost samples and exposure of the sample collector to unnecessary hazards.

Third, samples contained in the sampler were difficult to transfer into sample containers at regulated rates, and caused some samples to be lost from splashings.

Attempts were made to improve the first model of the Coliwasa. These efforts led to fabrication of the other models shown in Figures A-2 through A-5, and finally to the recommended version as shown in Figure 1 of the text.

Models 2 and 3

The improvement in the second model of the Coliwasa (Figure A-2) consisted of making diametrical slits, 5 cm(2 in.) deep by 2 cm(0.79 in.) wide, and indentations 90° from the slits at the top of the sampler tube. The slits accommodate the T-handle of the stopper rod in the open position, which allows the stopper to extend down about 5 cm(2 in.) below the bottom of the sampler. The indentations serve as support for the T-handle when the sampler is placed in the close position. When this improved Coliwasa was tested the neoprene stopper still did not readily line up with the bottom opening of the sampling tube. Several twisting manipulations of the stopper rod were required to bring the sampler into the close position. This problem was remedied by installing three stainless steel guide wires (18 gauge) on the stopper, with the upper wire ends secured to the stopper rod, as shown in Figure A-3. This version (Model 3) of the sampler was again tested. The sampler was found functional and relatively easy to operate. It can be disassembled and reassembled for cleaning in about 2 minutes. It can be built for less than \$10.00. The closing tension on the stopper of this sampler, however, is not easily adjusted while sampling. This drawback might incur some sample loss.

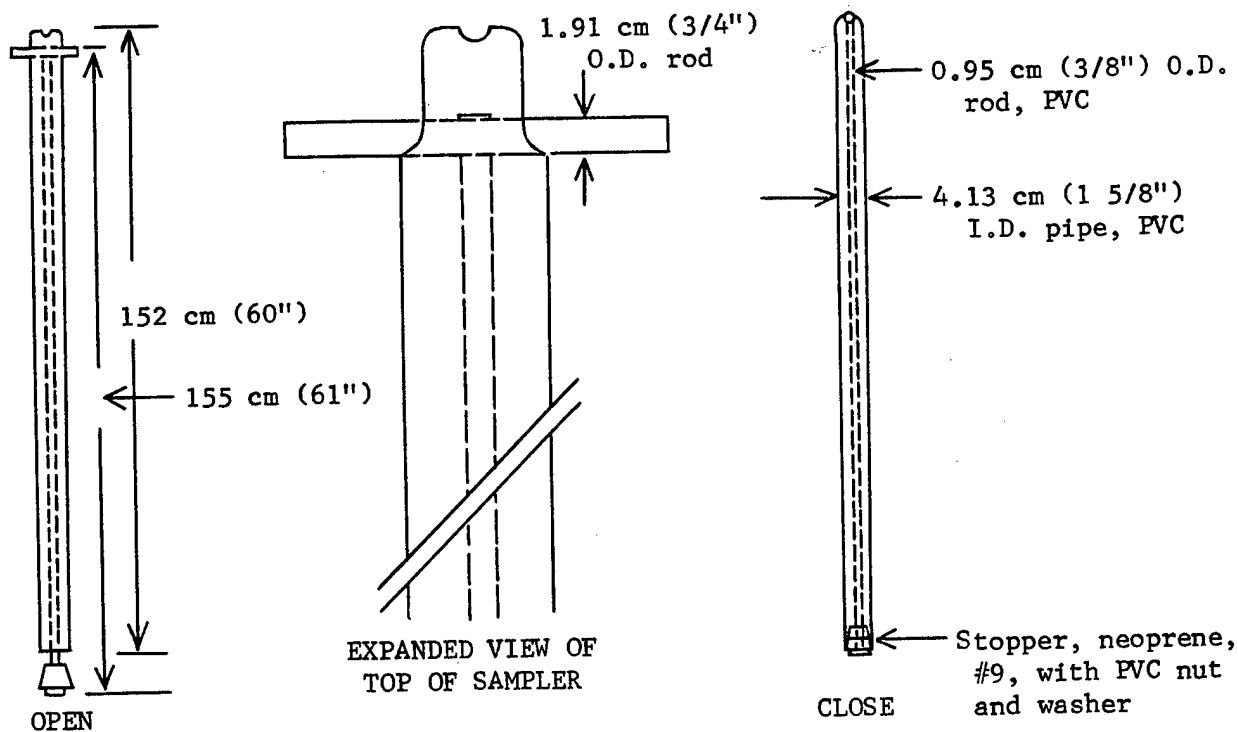

Figure A-2. Coliwasa, Model 2.

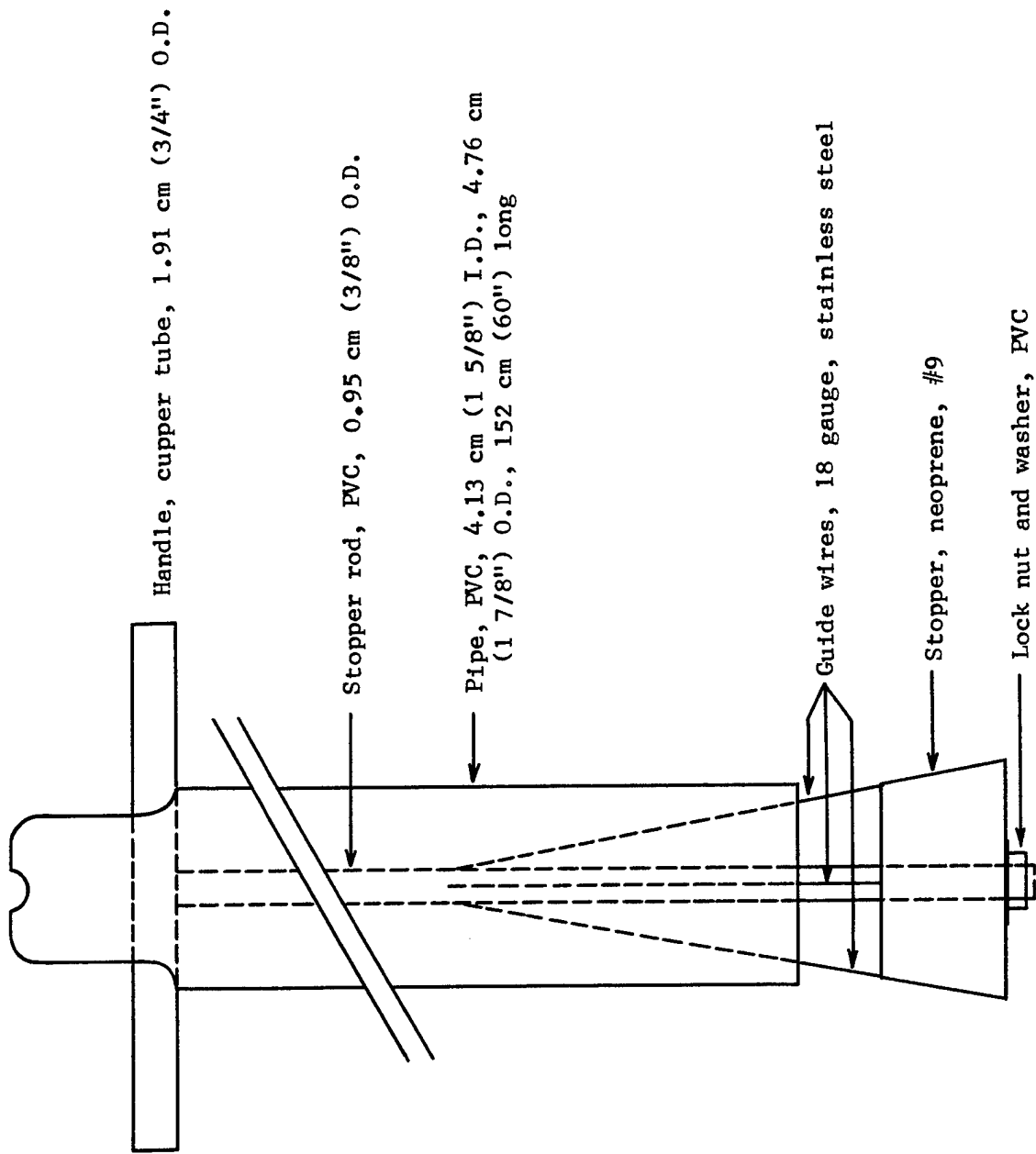

Figure A-3. Coliwasa, Model 3.

#### Model 4

Further investigation into improving the design of the Coliwasa resulted in Model 4 (Figure A-4). In this version, the locking mechanism of the sampler consisted of a threaded PVC plug that rides on a short threaded 0.95-cm (3/8-in.) O.D. metal rod. The metal rod is coupled with the PVC stopper rod. To sample, the plug is screwed out about 5 cm and then the stopper rod is pushed downward to open the sampler. The sampler is lowered slowly into the liquid. Upon reaching the bottom of the container, the stopper rod is pulled up to close the sampler. The PVC plug is screwed in until tight to secure the stopper in the close position. This design of the Coliwasa is simple, functional, and provides the person collecting the sample with control over the tightness of the stopper against the bottom of the sampler. It is, likewise, easily disassembled and reassembled for cleaning. This sampler, however, is slow to operate, the PVC plug does not screw in and out fast enough. This drawback tends to expose the sample collector to the liquid waste during sampling longer than is perhaps necessary.

#### Model 5

Another model of the Coliwasa was fabricated using a closing principle similar to a float valve (Figure A-5). This sampler was fabricated from a 1.52-m (5-ft) by 5.1-cm (2-in.) I.D. plastic pipe. At the bottom end is a plastic reducer fitting (5.1-cm (2-in.) to 3.18-cm (1.5-in.) I.D.). A manually operated neoprene rubber plug attached to a rod is used as the closing device. When sampling, the rubber plug is raised about 5 cm (2-in.) above its seat, and the sampler is slowly lowered into the liquid. On reaching the bottom of the container, the sampler is closed by slowly lowering the plug back to its seat. The sampler is withdrawn and the sample is discharged into a sample container. Tests performed on this sampler showed no leakage of collected samples. This sampler was also found to be the easiest to disassemble and reassemble for cleaning. However, the annular clearance between the outside diameter of the stopper and the inside diameter of the sampling tube was too narrow. The sampler tended to stir the liquid mixture on filling, which could incur the collection of nonrepresentative sample. In addition, the sampler tended to exclude large particles in the wastes. Increasing the tube/stopper annular clearance did not seem practical because it conversely reduced the opening of the reducer fitting of the sampling tube.

#### Final Design

A much improved and recommended model of the Coliwasa is shown in Figure 1 of the text. This model features three main improvements over the previous models. The first improvement consists of the use of a positive, quick engaging closing and locking mechanism. This mechanism consists of a short-length, channeled aluminum bar that is attached to the sampler's stopper rod by an adjustable swivel. The aluminum bar serves both as a T-handle and lock for the sampler's closure system. When the sampler is in the open position, the handle is placed in the T-position and pushed down against the locking block. This manipulation pushes out the

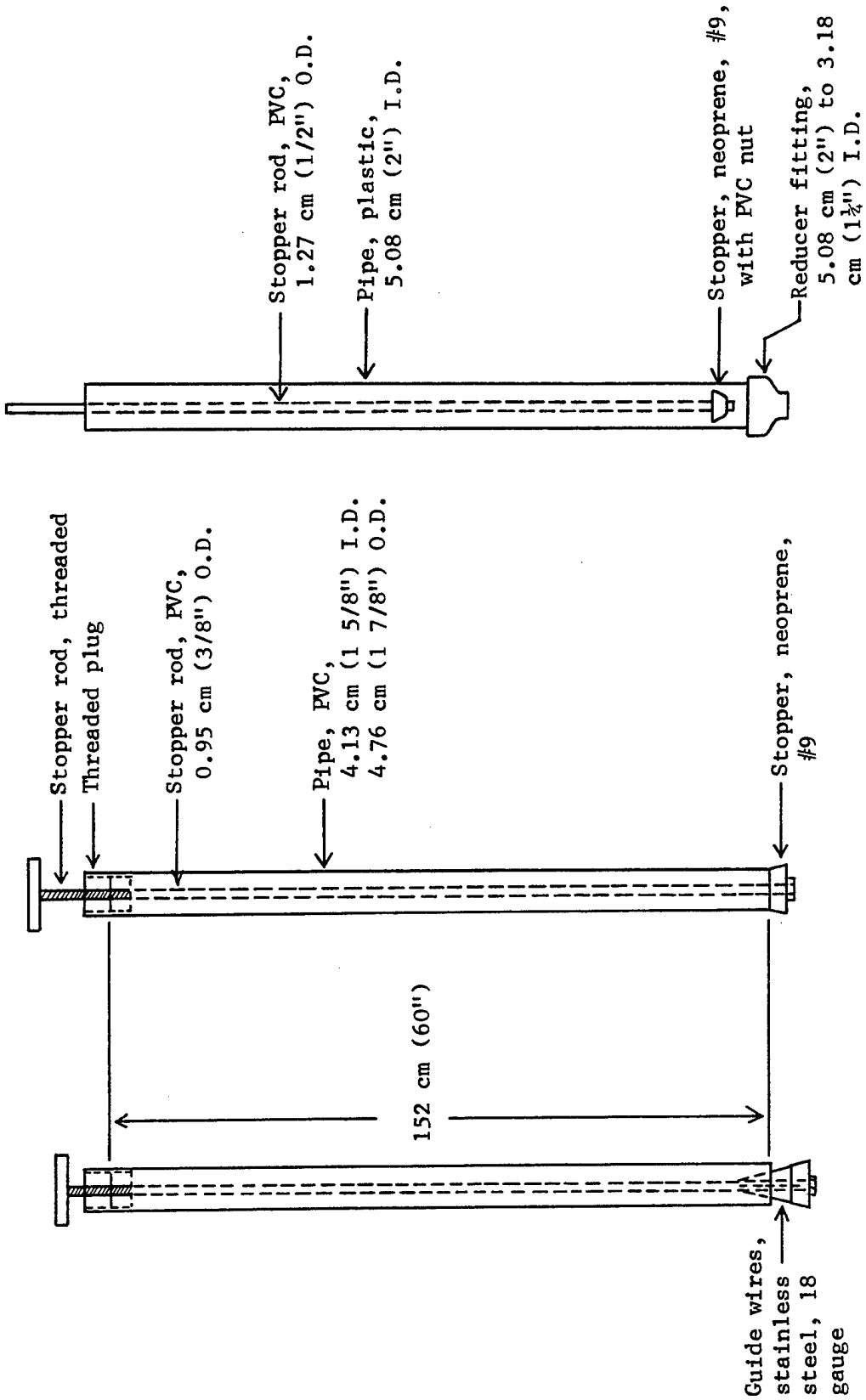

Figure A-4. Coliwasa, Model 4.

Figure A-5. Coliwasa, Model 5.

neoprene stopper and opens the sampling tube. In the close position, the handle is rotated until one leg of the T is squarely perpendicular against the locking block. This tightly seats the neoprene stopper against the bottom opening of the sampling tube and positively locks the sampler in the close position. The closure tension can be adjusted by shortening or lengthening the stopper rod by slightly screwing it in or out of the T handle swivel. In discharging a collected sample, the T handle is slowly brought into the T-position. This facilitates the opening of the sampler at a controllable rate and permits the transfer of the sample into a sample container at a regulated rate, thus minimizing splashing or loss of sample.

The second improvement made is the use of a sharply tapered neoprene stopper. The sharp taper of the stopper eliminates the use of guide wires and facilitates the proper seating of the stopper against the opening of the sampling tube on closure. This stopper can be fabricated to specifications by plastic products manufacturers at an extremely high price, or it can be made by simply grinding down the inexpensive and commercially available neoprene stopper to the desired taper with a shop grinder (Note 1 in Appendix B).

The third improvement is the use of translucent PVC and glass pipes as the sampling tubes. These tubes permit the observation of the phases of the liquid waste sample collected in the sampler. The glass sampling tube is usually used with a Teflon stopper rod. Each tube is used for different purposes, as described in Section 4 of the text.

The improved model of the Coliwasa was tested in the field and in the laboratory and found to be the most practical and capable of collecting representative samples of multiphase liquid wastes samples.

#### Laboratory Tests

In the laboratory, the testing was conducted using test liquid mixtures in a 122-cm (4-ft) tall by 15.2-cm (6-in.) I.D. glass cylindrical tank. The glass tank was ideal for the tests because it permitted observation and measurement of the relative heights of the liquid phases.

A two-phase liquid mixture consisting of about 13.9 liters of water and 3.29 liters of waste oil was sampled with the Coliwasa. The sample was emptied into a 1000-ml (1.056 qt) graduated cylinder. The relative volumes of the liquids were determined and given in Table A-1.

The results indicate that the Coliwasa is capable of obtaining a representative sample of a two-phase liquid mixture.

TABLE A-1.  
Relative Volumes of Liquids in the Two-Phase Mixture

Item	Oil	Water
% by height of phases in tank	19	81
% by volume collected	22	78

A three-phase mixture was sampled next. The mixture was prepared by combining waste oil, water, and trichloroethylene (TCE) in the test tank. The TCE extracted some of the waste oil and foamy emulsions formed at the oil/water and the water/TCE interfaces. However, three distinct phases were still obtained. Just like the previous experiment, the starting heights of the liquid phases for each trial were measured. The mixture was sampled with the Coliwasa. The samples were each discharged into 1000-ml (1.056 qt) graduated cylinders and the relative volumes of the liquid phases were determined (Table A-2).

TABLE A-2.  
Relative Volumes of Liquids in the Three-Phase Mixture

Item	Oil	Aqueous	TCE
Trial I:			
% by height of phases in tank	7.9	77.4	14.7
% by volume collected	9.7	79.6	10.8
Trial II:			
% by height of phases in tank	9.3	75.0	15.0
% by volume collected	10.2	79.0	10.7
Average:			
% by height of phases in tank	8.8	76.0	15.0
% by volume collected	9.8	79.0	11.0

The results indicate that the Coliwasa is capable of collecting a representative sample of a three-phase mixture within 5% accuracy. The greatest nonrepresentative error, as anticipated, occurred at the bottom phase because the sampler's rubber stopper prevents sampling of the last 2.54 cm (1 in.) to the bottom of the container. This error decreases as the bottom phase increases in volume as compared to the upper phases. With less viscous and completely immiscible test liquids, the representativeness of the sample collected approaches unity.

#### Field Tests

The field tests consisted of sampling liquid wastes in drums and in vacuum trucks. Drums of unknown liquid wastes are sampled at a hazardous waste (Class I) disposal site in California. The sampler, which has a 4.8-cm (1 7/8-in.) O.D., easily cleared through the drum's bung holes.

Sampling was relatively fast. From the time a drum was opened, a sample was collected and transferred into a container in less than 5 minutes. While a sample was in the sampler, no leakage was detected, indicating a positive seal by the sampler's closing mechanism. On the transfer of sample to a container, no splashing was observed, showing that the sampler's content can be discharged at a regulated rate.

A drum containing a two-phase liquid waste mixture was also sampled. Replicate samples were obtained, and each was placed in separate containers. The ratios of the liquid phases in each of the samples were determined and found to be approximately the same, indicating that reproducible samples can be collected with the sampler.

Incoming vacuum trucks carrying liquid wastes to the disposal site were sampled next with the Coliwasa. Again, the sampler was found to be functional and very easy to use. Collection of samples was very fast, minimizing the exposure of the sample collector to hazardous fumes and other emissions from the wastes. Only one vacuum truck with a narrow hatch opening and a total depth of about 163 cm (5.3 ft) was not successfully sampled. The sampling tube of the Coliwasa is only 152 cm (5 ft) long. A longer sampling tube (i.e., 183 cm (6 ft) long) could have remedied the problem.

APPENDIX B. PARTS FOR CONSTRUCTING THE COLIWASA

Item	Supplier	Approximate Cost <sup>a</sup>
Sample tube, PVC plastic, translucent, 4.13 cm(1 5/8 in.) I.D. X 1.52 m(5 ft) long X 0.4 cm(5/32 in.)	Plastic supply houses	\$ 4.00 each
Sample tube, glass borosilicate, 4.13 cm(1 5/8 in.) I.D. X 1.52 m (5 ft) long, Code 72-1602.	Corning Glass Works, Corning, N.Y.	\$18.00 each
Stopper, rubber, neoprene, #9, modified as described in footnote. <sup>b</sup>	Laboratory supply	\$ 6.00/0.45 kg(lb)
Stopper rod, PVC, 0.95 cm(3/8 in.) O.D. X 1.67 m(5½ ft) long.	Plastic supply houses	\$ 5.00/6.1 m (20 ft)
Stopper rod, Teflon, 0.95 cm(3/8 in.) O.D. X 1.67 m(5½ ft) long.	Plastic supply houses	\$30.00/3.05 m (10 ft)
Locking block without sleeve, PVC, 3.8 cm(1½ in.) O.D. X 10.2 cm(4 in.) long with 1.11-cm(7/16 in.) hole drilled through center.	Fabricate. Rods available at plastic supply houses. Can be bought in 30.48 cm(1 ft)length	
Sleeve, PVC, 4.13 cm(1 5/8 in.) I.D. X 6.35 (2½ in.) long.	Fabricate from stock of PVC pipe. Available at plastic supply houses	\$ .80/30.48 cm(ft)
T-handle, aluminum, 18 cm(7 in.)long X 2.86 cm(1 1/8 in.) wide with 1.27 cm(½ in.) wide channel.	Fabricate. Aluminum bar stock available at hardware stores.	\$3.00/1.83 m(6 ft)
Swivel, aluminum bar, 1.27 cm(½ in.) square X 3.8 cm(1½ in.)long with 3/8 National Coarse (NC) inside thread to attach stopper rod.	Fabricate. Aluminum bar stock available at hardware stores.	\$ 3.00/1.83 m(6 ft)
Nut, PVC, 3/8 in. NC thread	Plastic supply houses	\$ .03 each
Washer, PVC, 3/8 in.	Plastic supply houses	\$ .03 each
Nut, SS, 3/8 in., NC	Hardware stores	\$ .10 each
Washer, SS, 3/8 in.	Hardware stores	\$ .10 each
Bolt, 3.12 cm(1 ¼ in.)long X 3/16 in.	Hardware stores	\$ .10 each
Nut, 3/16 in., NC	Hardware stores	\$ .03 each
Washer, lock 3/16 in.	Hardware stores	\$ .03 each

<sup>a</sup> 1977 prices

<sup>b</sup> Shape the stopper into a cone as follows: Bore a 0.95-cm(3/8-in.) diameter center hole through the stopper. Insert a short piece of 0.95-cm(3/8-in.) O.D. handle through the hole until the end of the handle is flush against the bottom (smaller diameter) surface of the stopper. Carefully and uniformly turn the stopper into a cone against a grinding wheel. This is done by turning the stopper with the handle and grinding it down conically from about 0.5 cm(3/16 in.) of the top (larger diameter) surface to the edge of the 0.95-cm(3/8-in.) hole on the bottom surface.

APPENDIX C. CHECKLIST OF ITEMS REQUIRED IN THE FIELD SAMPLING OF HAZARDOUS WASTES.

Quantity	Item	Use	Supplier	Approximate Cost
1	Coliwasa, plastic type (Section 4)	To sample liquid wastes, except ketones, nitrobenzene, dimethylforamide, tetrahydrofuran and pesticides	Fabricate; Parts can be purchased from hardware stores (see Section 4)	\$ 16.00
1	Coliwasa, glass type (Section 4)	To sample liquid waste with pesticides, and other wastes that cannot be sampled with plastic Coliwasa except strong alkali and hydrofluoric acid solution	Fabricate; Glass tube available from Corning Glass Co. Corning, N.Y. 14830 (see Section 4)	\$ 25.00
1	Soil sampler, auger (Section 4)	To sample contaminated soil, dried ponds, etc.	Weyco Distributor 1417 Heskett Way Sacramento, Calif. 95825	\$ 70.00
1	Grain sampler (Section 4)	To sample powdered or granular wastes	Laboratory supply houses	\$ 50.00
1	Scoop, stainless steel blade (Section 4)	To sample top soil or shallow layers of solid wastes	Cole-Parmer Instruments Chicago, Ill.	\$ 25.00

APPENDIX C (continued).

Quantity	Item	Use	Supplier	Approximate Cost
1	Veihmeyer soil sampler (Section 4)	To collect soil core samples	Hansen Machine, 334 N. 125h St., Sacramento, Calif. 95815	\$ 200.00
1	Pond sampler (Section 4)	To sample ponds, pits, etc.	Fabricate (see Section 4). Clamps available at Cole-Parmer Instrument 3060 Gibraltar Ave. Costa Mesa, Calif. 92626	\$ 9.00
			Telescoping handle available at swimming pool supply houses	\$ 16.24
1	Trier, single slot (Section 4)	To sample granular and powdered material in piles, sacks, fiberdrums, etc.	Curtin-Matheson Scientific 470 Valley Drive P.O.Box 386 Brisbane, Calif. 94005	\$ 25.00
1	Waste pile sampler (Section 4)	To sample waste piles	Fabricate. PVC pipe available at hardware stores (see Section 4)	\$ 3.00
6	1000 -,2000-ml (1-qt,2-qt) linear polyethylene	To contain solid and liquid samples except pesticides and chlorinated hydrocarbons	Laboratory supply houses	\$ 11.00/ pkg.6
1	Coverall, long-sleeved, cotton	Protective garment	Clothing stores	\$ 14.00
1	Suit, neoprene rubber, long-sleeved	Protective garment	MSA, Catalog #33496	\$ 210.00
1 pair	Gloves, neoprene rubber	Protective garment	Laboratory supply houses	\$ 4.20

## APPENDIX C (continued).

Quantity	Item	Use	Supplier	Approximate Cost
1	Self-contained breathing apparatus	For use in atmospheres deficient in oxygen or otherwise immediately dangerous to life.	MSA, Catalog #461704, Model 401 or equivalent	\$580.00
1	Respirator, chemical cartridge type	For use in atmospheres not immediately dangerous to life	Comfo 11 Respirator, MSA, Catalog #460968 or equivalent	\$ 9.00
4	Cartridges for respirator	For use in atmospheres not immediately dangerous to life	GMC Cartridge, MSA Cat.#459317 & GMD Cartridge, MSA Cat.#459318 or equivalent	\$ 5.00
1 pair	Goggles	Eye protection	MSA, Cat.#79179 or equivalent	\$ 5.00
1	Portable eyewash	For emergency eyewash	Laboratory supply houses	\$ 4.00
1	Fire extinguisher	Fire suppression	Scientific Products S1365-1 or equivalent	\$ 60.00
1	Hard hat	Head protection	MSA, Cat.#454740 or equivalent	\$ 5.00
1	Gas mask	For use in contaminated atmospheres immediately dangerous to life	MSA, Cat.#448983 or equivalent	\$ 70.00
1	18.9-liter (5-gal) water in cubitainer or equivalent with spigot	For miscellaneous washing purposes	Laboratory supply houses	\$ 5.50
6	Teflon liners for Bakelite caps	To provide inert cap liners	Scientific Specialties, P.O.Box 352 Randallstown, Md. 21133 or other suppliers	\$ 9.00
12 each	Sample labels, seals, sample analysis request sheets, chain of custody records	To document sample	Design using information from Section 6	

APPENDIX C (continued).

Quantity	Item	Use	Supplier	Approximate Cost
1	Field log book (Section 6)	To keep sample records	Office supply stores	\$ 2.00
1	Weighted bottom sampler (Section 4)	To sample storage tanks or similar containers	Fabricate (see Section 4 and Figure 9)	\$ 25.00
1	Disposable towels or rags	To clean sampling equipment	Terry towels or equivalent. Available at chemical supply houses	\$ 4.00/ pkg.
6	Large polyethylene bags	To store waste papers, rags, etc.	Plastic supply houses	\$ 11.00/ pkg/100
12	Polyethylene bags	To store sample containers	Plastic supply houses	\$ 4.00/ pkg/100
4	Waterproof pens	To complete records and labels	Stationery stores	\$ 3.00
1	Technical grade trichloroethylene	To clean samplers	Chemical supply stores	\$ 22.00/ gal.
1	Apron, oil and acid proof	Protective garment	McMaster-Carr Co. P.O.Box 4355 Chicago, Ill.	\$ 9.00
1	Face mask	Protective garment	MSA 400 Penn Center Blvd. Pittsburg, Pa. 15235	\$ 4.00
1	18.9 liter (5-gal) can	To store used cleaning solvent	Hardware stores	\$ 5.00

APPENDIX D. RANDOM SAMPLING

Random Numbers

03	47	43	73	86	36	96	47	36	61	46	98	63	71	62
97	74	24	67	62	42	81	14	57	20	42	53	32	37	32
16	76	62	27	66	56	50	26	71	07	32	90	79	78	53
12	56	85	99	26	96	96	68	27	31	05	03	72	93	15
55	59	56	35	64	38	54	82	46	22	31	62	43	09	90
16	22	77	94	39	49	54	43	54	82	17	37	93	23	78
84	42	17	53	31	57	24	55	06	88	77	04	74	47	67
63	01	63	78	59	16	95	55	67	19	98	10	50	71	75
33	21	12	34	29	78	64	56	07	82	52	42	07	44	38
57	60	86	32	44	09	47	27	96	54	49	17	46	09	62
18	18	07	92	46	44	17	16	58	09	79	83	86	19	62
26	62	38	97	75	84	16	07	44	99	83	11	46	32	24
23	42	40	64	74	82	97	77	77	81	07	45	32	14	08
52	36	28	19	95	50	92	26	11	97	00	56	76	31	38
37	85	94	35	12	83	39	50	08	30	42	34	07	96	88
70	29	17	12	13	40	33	20	38	26	13	89	51	03	74
56	62	18	37	35	96	83	50	87	75	97	12	25	93	47
99	49	57	22	77	88	42	95	45	72	16	64	36	16	00
16	08	15	04	72	33	27	14	34	09	45	59	34	68	49
31	16	93	32	43	50	27	89	87	19	20	15	37	00	49

HOW TO USE THE TABLE OF RANDOM NUMBERS:

1. Based on available information, segregate the containers (i.e., drums, sacks, etc.) according to waste types.
2. Number the containers containing the same waste types consecutively, starting from 01.
3. Decide on how many samples you wish to take. This number is usually determined by the objective of the sampling. For regular surveillance sampling, the collection of one or two samples is usually adequate. In this case, random sampling is not necessary. But for regulatory or research purposes, more samples (such as one sample for every group of five containers) taken at random will generate more statistically valid data. Hence if there were 20 drums containing the same type of waste, 5 drums have to be sampled.
4. Using the set of random numbers above, choose any number as a starting point.
5. From this number, go down the column, then to the next column to the right, or go in any predetermined direction until you have selected five numbers between 01 and 20, with no repetitions. Larger numbers are ineligible.

Example: If you were to choose 19 as the starting point on column four, the next eligible numbers as you go down this column are 12 and 04. So far you have chosen only three

eligible numbers. Proceed to the next column to the right. Going down and starting from the top of this column, the next eligible numbers are 12 and 13. But 12 is already chosen. Proceeding to the sixth column, the next eligible number is 16. Your five random numbers, therefore, are 19, 12, 04, 13 and 16. Thus the drums with corresponding numbers have to be sampled.

#### APPENDIX E. SYSTEMATIC ERRORS USING THE COLIWASA

Certain systematic errors may occur in the determination of relative phase composition of waste when using the Coliwasa. This error, in which certain phases are disproportionately represented, results from the use of a straight-sided sample tube to sample a container (tank truck) with a circular cross section. On the basis of a two-phase system, error is at a minimum when the phase interface is at the tank center and at a maximum when the interface is near the bottom or top of the tank. These errors do not occur when sampling a drum or other container when sampling is done down the axis of the container (cylinder).

Errors in relative phase composition encountered in sampling the typical cylindrical vacuum truck may be estimated using Table E-1. Numbers given in the table are representative values calculated from the equations given below, which relate the geometry of the sample tube to the geometry of the tank truck.

$$\% A(\text{tank}) = \frac{(\theta - \sin \theta)}{2\pi}$$

$$\% A(\text{sample}) = \frac{1 - \cos \frac{1}{2} \theta}{2}$$

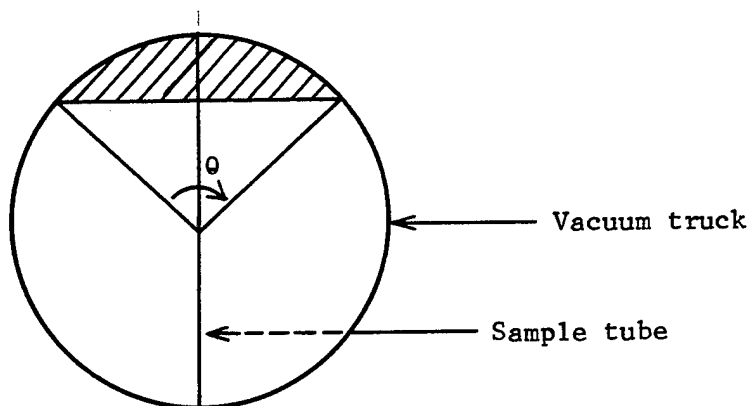

TABLE E-1. SAMPLE VOLUME CORRECTION FACTORS WHEN  
 SAMPLING CYLINDRICAL TANKS WITH COLIWASA

% A in sample	% A in tank	Correction (%)
10	5.20	+ 4.80
20	14.2	+ 5.8
30	25.2	+ 4.8
40	37.4	+ 2.6
50	50	0
60	62.6	- 2.6
70	74.8	- 4.8
80	85.8	- 5.8
90	94.8	- 4.8
100	100	0

TECHNICAL REPORT DATA (Please read instructions on the reverse before completing)		
1. REPORT NO. EPA-600/2-80-018	2.	3. RECIPIENT'S ACCESSION NO.
4. TITLE AND SUBTITLE Samplers and Sampling Procedures for Hazardous Waste Streams	5. REPORT DATE January 1980 (Issuing Date)	
	6. PERFORMING ORGANIZATION CODE	
7. AUTHOR(S) Emil R. deVera, Bart P. Simmons, Robert D. Stephens and David L. Storm.	8. PERFORMING ORGANIZATION REPORT NO.	
9. PERFORMING ORGANIZATION NAME AND ADDRESS Hazardous Materials Laboratory California Department of Health Services 2151 Berkeley Way Berkeley, CA 94704	10. PROGRAM ELEMENT NO. C73D1C, SOS #1, Task 32	
	11. CONTRACT/GRANT NO. R 804692010	
12. SPONSORING AGENCY NAME AND ADDRESS Cin., OH Municipal Environmental Research Laboratory-- Office of Research and Development U.S. Environmental Protection Agency Cincinnati, Ohio 45268	13. TYPE OF REPORT AND PERIOD COVERED Final	
	14. SPONSORING AGENCY CODE EPA/600/14	
15. SUPPLEMENTARY NOTES Richard A. Carnes, Project Officer (513/684-7871)		
16. ABSTRACT <p>The goal of this project was to develop simple but effective sampling equipment and procedures for collecting, handling, storing, and recording samples of hazardous wastes. The report describes a variety of sampling devices designed to meet the needs of those who regulate and manage hazardous wastes. Particular emphasis is given to the development of a composite liquid waste sampler, the Coliwasa. This simple device is designed for use on liquid and semi-liquid wastes in a variety of containers, tanks, and ponds. Devices for sampling solids and soils are also described.</p> <p>In addition to the sampling devices, the report describes procedures for development of a sampling plan, sample handling, safety precautions, proper recordkeeping and chain of custody, and sample containment, preservation, and transport. Also discussed are certain limitations and potential sources of error that exist in the sampling equipment and the procedures. The statistics of sampling are covered briefly, and additional references in this area are given.</p>		
17. KEY WORDS AND DOCUMENT ANALYSIS		
a. DESCRIPTORS	b. IDENTIFIERS/OPEN ENDED TERMS	c. COSATI Field/Group
Samplers Lagoons (ponds)--waste disposal Hazardous materials	Representative sampling Composite sampling Sampling plans Sampling procedures Hazardous waste Composite liquid waste sampler	68C
18. DISTRIBUTION STATEMENT  Release unlimited	19. SECURITY CLASS (This Report) unclassified	21. NO. OF PAGES 78
	20. SECURITY CLASS (This page) unclassified	22. PRICE

United States  
Environmental  
Agency

Environmental Research Information  
Center  
Cincinnati OH 45268

Postage  
Fees Paid  
Environmental  
Protection  
Agency  
EPA-335



Official Business  
Penalty for Private Use, \$300

Special Fourth-Class Rate  
Book

Please make all necessary changes on the above label,  
detach or copy, and return to the address in the upper  
left-hand corner.  
If you do not wish to receive these reports CHECK HERE :  
detach, or copy this cover, and return to the address in the  
upper left-hand corner.

EPA-600/2-80-018