

MDDC - 1010

UNITED STATES ATOMIC ENERGY COMMISSION

CONSTRUCTION FEATURES OF A CIRCUIT FOR COINCIDENCE MEASUREMENTS
AND APPLICATIONS OF THE CIRCUIT TO NUCLEAR PROBLEMS

by
C. D. Moak

EXEMPTION STATEMENT A
Approved for public release
Distribution Unlimited

Argonne National Laboratory

LIBRARY OF CONGRESS
SCIENCE & TECHNOLOGY DIVISION
READINGS ROOM

Date of Manuscript: April 30, 1945.
Date Declassified: May 20, 1947.

Issuance of this document does not constitute
authority for declassification of classified
copies of the same or similar content and title
and by the same author.

JAN 7 1946

19970204 074

Technical Information Division, Oak Ridge Operations
AEC, Oak Ridge, Tenn., 12-20-48--850-A4601

Printed in U.S.A.
PRICE 10 CENTS

DEC QUALITY INSPECTED 2

215599

CONSTRUCTION FEATURES OF A CIRCUIT FOR COINCIDENCE MEASUREMENTS
AND APPLICATIONS OF THE CIRCUIT TO NUCLEAR PROBLEMS

- a) Conversion Coefficients of Au¹⁹⁸ and Xe¹³⁵
b) Gamma-Ray Energy Measurements by Compton-Recoil Absorption

By C. D. Moak

INTRODUCTION

The inherent characteristics required of a coincidence circuit for nuclear research, as pointed out by Norling¹ are:

1. High resolving power.
2. The ability of the circuit to function properly at high single counting rates.
3. Low sensitivity to external electrical disturbances.
4. The circuit shall register a constant percentage, or preferably all of the coincidences.

It has been found here that each of the listed characteristics is more or less dependent upon the others so that optimum operating conditions must be determined. For example, it is known that if the resolving power of a circuit is made very high, the circuit will only count a fraction of the true coincidences, an effect which will be explained later. Such a condition might be improved to a small extent by increasing the amplification of the circuit but this procedure usually increases the sensitivity of the circuit to external electrical disturbances. If the resolving power is decreased by a large amount, the chance coincidence rate will obscure the real coincidence rate.

An outline of the uses of a coincidence circuit and an outline of the present basic design principles are in order here. The coincidence circuit has been found valuable in the examination of the decay schemes of natural and artificial radioactivities, i.e. the evaluation of internal conversion coefficients or the determination of γ/β ratios. It has been used to measure gamma ray energies by Compton recoil absorption. Some work has been done also in the measurement of very short half-lives. The detection of certain radioactive isotopes in the presence of large radioactive contaminations is made possible through the use of the coincidence circuit.

DESCRIPTION OF THE CIRCUIT

The heart of the present day coincidence circuit is the Rossi stage.² Described in terms of triodes, the stage might be designed as shown in Figure 1. The circuit consists of any number triodes with plates fed through a common resistor R_p but with grids driven by separate counter tubes. For simplicity the two-channel case will be assumed throughout the paper. The vacuum-tube characteristics of T_1 and T_2 might appear as Line A in Figure 2 (a) with the load line of R_p as shown intersecting A at Y. When the plates of T_1 and T_2 are connected in parallel the characteristics of $T_1 + T_2$ would simply have ordinates twice those of A giving the line B with the load line intersection at X. Now, when a

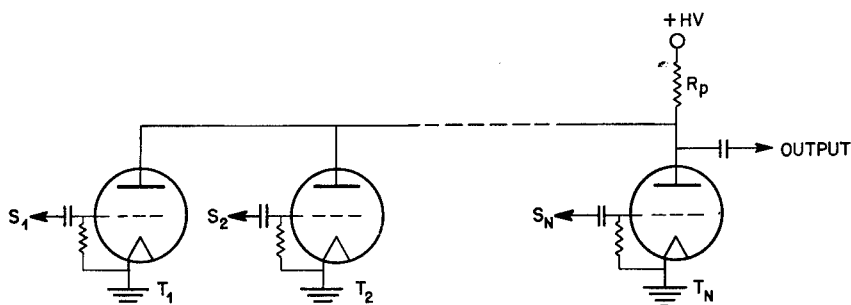

Figure 1. Basic Rossi stage.

negative pulse strikes the grid of T_1 cutting its plate current off, the operating point becomes that of the single tube T_2 operating at point Y on line A so that a small pulse equal to S appears at the output. However, when two pulses each strike the grids of T_1 and T_2 simultaneously the current through R_p is completely cut off so that the operating point moves from X up to Z or the high-voltage potential so that a pulse of the size C, as shown, would appear at the output. These are coincidence pulses and they may be caused by the simultaneous discharge of two counters. Using triodes in the Rossi stage, these pulses may be three or four times as great as the small pulses produced by single pulses in either channel. The assumption is made that the counter tube pulses have been sufficiently amplified so that they will drive the grids of the Rossi stage to cut-off point. The situation is greatly complicated by the fact that with very short, sharp pulses the interelectrode capacitances of the tubes limit the action of the circuit.

Figure 2(b) shows the curves for a Rossi stage using pentodes. Theoretically the discrimination between single counts and coincidence counts should be greater for the pentodes, as shown, but interelectrode capacitances are greater so the advantages gained by using pentodes are small. One thing is evident from this, that although the Rossi stage discriminates against single counts in favor of coincidences, nevertheless single count pulses do appear in the output. The use of some sort of stage with an excitation threshold above the voltage of these single count pulses following the Rossi stage is clearly indicated. The writer has used a trigger stage following the Rossi stage for the reason that its output pulses are of constant magnitude regardless of the magnitude of those excitation pulses which are above the excitation threshold.

So far it has been assumed in the basic design that all counter pulses (or pulses striking the Rossi stage grids) are of equal magnitude and of sufficient magnitude to extinguish a tube in the Rossi stage. The ratio of pulse magnitudes of a standard glass Geiger tube and a mica-window β counting tube may easily be an order of magnitude. Now it is desirable in the interest of high resolving power that the dead time per pulse of a Rossi-tube be as small as possible. If simple amplifiers precede the Rossi stage complications immediately arise; one can easily see that if the sensitivity of the amplifiers is such that a pulse from a β counter will block a Rossi tube then if one replaces the β counter with a standard glass counter, such a counter will block a Rossi tube upon rising to one-tenth its full pulse magnitude and will hold that Rossi tube blocked until the pulse has returned to the threshold value. Thus using a simple amplifier preceding each Rossi tube, the resolving power of the entire circuit will depend to some extent upon the nature of the pulses entering the circuit.

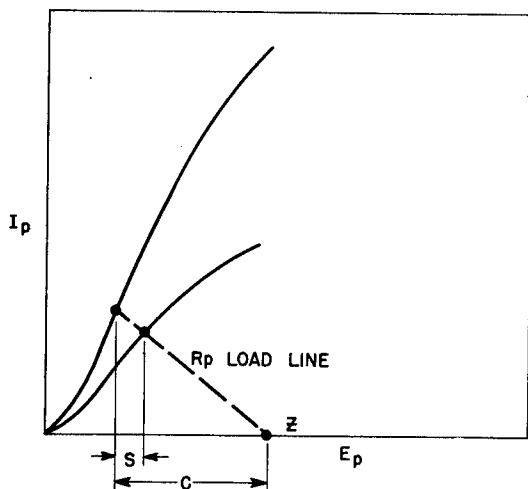
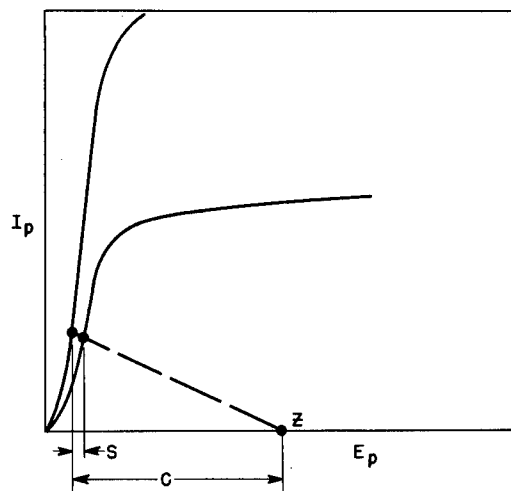

Figure 2(a). Curves for Rossi stage using triodes.

Figure 2(b). Curves for Rossi stage using pentodes.



Another difficulty which arises is the fact that all counter tubes operated at high counting rates give a certain percentage of so-called immature pulses. If one particle to be counted follows very closely upon another, it is likely that the counter will not be capable of returning to normal rapidly enough to receive the following particle so that the counter may deliver a pulse of much less than normal magnitude. If such a pulse were to come from a β counter in the previously mentioned circuit, it would be incapable of blocking the Rossi tube to which it is applied, and, therefore, incapable of producing a full-sized coincidence pulse if the other Rossi stage were blocked simultaneously, with the result that a pulse would appear at the Rossi output which would fall somewhat short of a full-sized coincidence pulse. From these considerations, a trigger circuit preceding the Rossi stage whose excitation threshold may be set at approximately one-third the pulse magnitude of a β counter and whose output pulse shape and magnitude are independent of input pulse shape or magnitude is clearly indicated. Such a trigger circuit has been developed by Bradley³ and is widely used in coincidence circuit work. It is so designed that its output pulses are capable of turning a Rossi tube off and on in a very short time interval.

A two-stage amplifier is used to drive these trigger circuits with gain adjusted so that the triggering threshold is at about 0.2 v at the input to the circuit. Thus the coincidence circuit dictated by

experience is as follows: A two-stage amplifier followed by a trigger circuit in each channel, the channels each driving a grid of a triode or pentode Rossi stage followed by a trigger circuit output stage. The diagram of such a circuit would be as shown in Figure 3. Two circuits of this type have been built here and both have nearly equal characteristics. The layout here has involved the use of three scalars. Bradley⁴ has designed a dual scalar for this work which consists of two Higginbotham scales of 256 for counting the single counts directly. An Offner scale of 64 is used connected to the output of the coincidence circuit. With this arrangement single counts and coincidence counts may be run simultaneously. The three units are mounted together in a cabinet, as shown in the photograph.

CHARACTERISTICS OF THE CIRCUIT

Having thus developed a basic coincidence circuit, it must now be ascertained whether or not the properties desired, as outlined in the beginning, have been attained. The first of these properties is high resolving power. When counters are connected to the two channels of a coincidence circuit and are made to count the radiations from two separate sources, there is a certain probability that a count in one channel will occur within a small time interval of a count in the other channel. This probability decreases as the small time interval is decreased. The time interval above which a circuit can reject these chance coincidences is the resolving time of the circuit and a measure of its resolving power, i.e., if pulses in each channel of a circuit must be 10^{-6} sec or less apart in time in order to be registered as coincidences, then one says that the resolving time of the circuit is 10^{-6} sec. This factor may be determined in the following way:⁵

$$A_{12} = 2N_1 N_2 \tau \text{ for two channels} \quad (1a)$$

$$A_{123} = 3N_1 N_2 N_3 \tau^2 \text{ for three channels} \quad (1b)$$

$$A_{123 \dots n} = 3N_1 N_2 \dots N_n \tau^{n-1} \text{ for } n \text{ channels} \quad (1c)$$

where the N 's are the single counting rates and A the chance coincidence rate assuming τ for any two channels to be the same and assuming separate sources of counts for each channel. If τ is different for different pairs of channels:

$$A_{12 \dots n} = (N_1 \tau_1 N_2 \tau_2 \dots N_n \tau_n) \left(\frac{1}{\tau_1} + \frac{1}{\tau_2} \dots + \frac{1}{\tau_n} \right). \quad (1d)$$

It is desirable that τ be as small as possible so that the chance coincidence rate shall not obscure the real coincidence rate. Here the advantage of the pentode Rossi stage and variable threshold output trigger circuit is seen. Assume a Rossi stage whose resolving time is 2×10^{-6} sec. If two pulses differ in time by, say, 1.5×10^{-6} sec, the later pulse will strike its Rossi tube before the other Rossi tube is completely conducting (i.e. back to normal). These "near misses" produce pulses of intermediate size in the output of the Rossi stage. By setting the threshold of the output trigger stage so that real coincidence pulses are barely great enough to trip the output circuit, those below that magnitude will be rejected. The circuit described in this paper may be set to any resolving time within the range 10^{-7} to 10^{-5} sec.

The second requirement of a coincidence circuit is that it be capable of functioning properly at high single counting rates. It has been found that the effective resolving time of a counter tube (i.e., dead time) is about 3×10^{-4} sec so that one would expect the circuit to be better than the counter tubes in this respect since the pulse duration in the circuit is everywhere less than 10^{-5} sec.

The third requirement is that the circuit have low sensitivity to external disturbances. This has been accomplished, as is the usual procedure, by setting the input sensitivity to approximately 0.2 v.

The fourth requirement of the circuit is that it count a constant percentage or preferably all of the true coincidences. Checking this property is sometimes rather difficult. This fact tends to explain the rather large spread in some of the results of coincidence work as quoted in the literature.

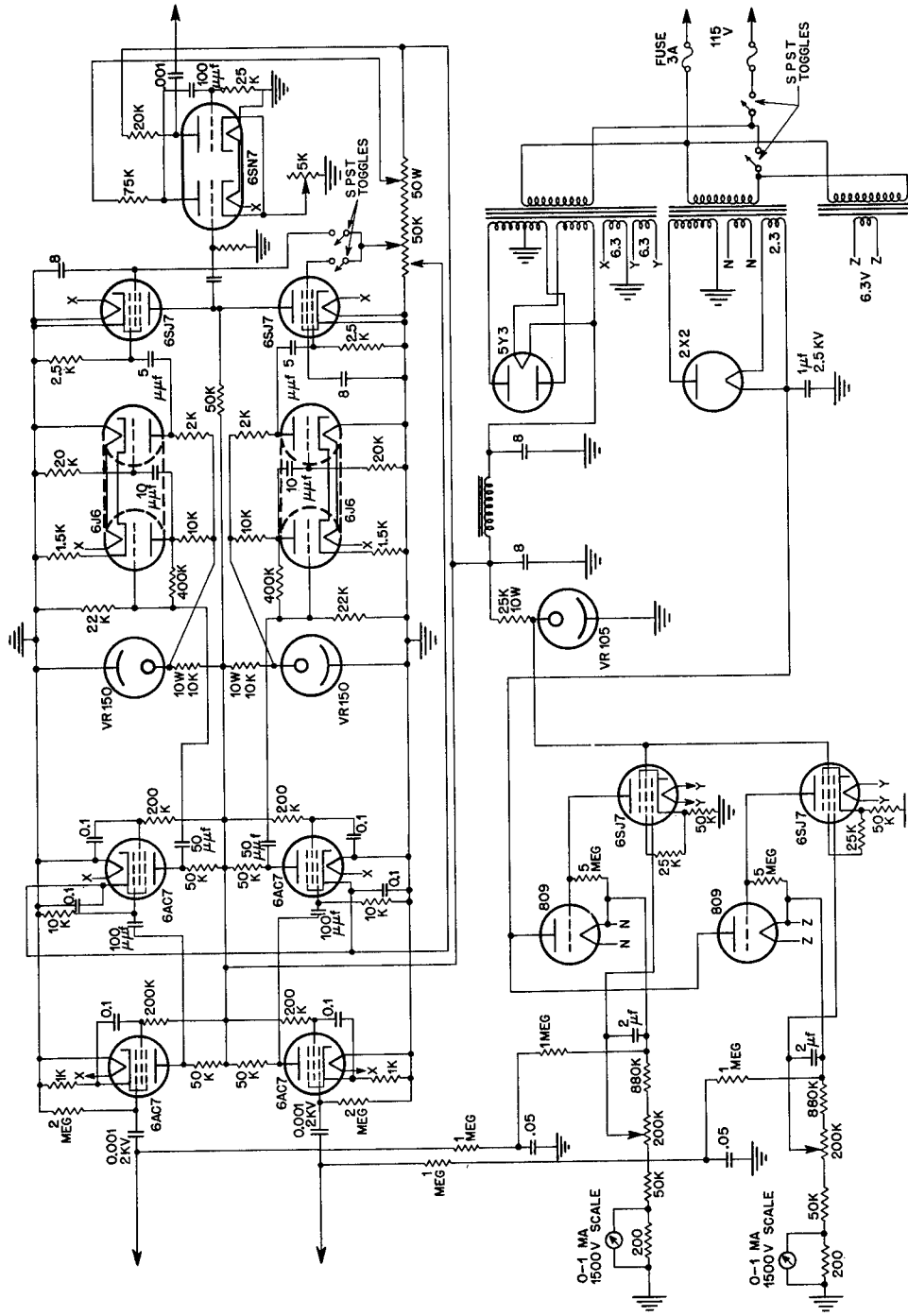

Figure 3. Coincidence circuit with dual power supply.

Electronic methods have been devised for testing the circuit. Periodic pulses resembling counter pulses at a frequency of 2×10^4 cps were fed into first one channel, then the other, and then both. When the pulses were fed through both channels simultaneously at $\tau = 10^{-7}$ sec no loss of coincidences could be detected. Also, the pulse size in one channel was varied relative to the pulse size in the other. Again, no loss was observed. This proved that the coincidence circuit does not lose coincidences. However, this did not prove that the combination of coincidence circuit and counter tubes would not cause a loss of coincidences. It has been found⁶ that there is a variable time-lag from the instant a particle traverses a counter until a pulse begins to appear on the positive wire of the counter. The magnitude of this lag is of the order of several microseconds and varies slightly with counter voltage and gas pressure.

It is generally believed that fluctuations in time-lag are the cause of real coincidences being lost at low resolving times. Usually one can operate at a resolving time of 10^{-6} sec or higher without these effects being appreciable. If one wishes to use a resolving time less than 10^{-6} sec, it is advised that care be taken to determine if the system is losing coincidences, and, if so, to determine accurately what the percentage loss is. It may be stated here that some counters using only a pure gas have been shown to have time lags much less than several microseconds, some having lags less than 10^{-7} sec. However, if one wishes to use a conventional vapor-quenching argon-alcohol counter at low resolving times, the loss of coincidences should be checked just before taking any coincidence data.

The procedure followed here in using two mica-window counters involves the use of a special type counter. As shown in Figure 4, one of the counters has a small hole drilled in the closed end. A mica window is waxed over the hole and a source of β particles placed directly against the small mica window so that β particles may pass through the special counter into another conventional β counter. With this geometry, any β particles entering counter 2 must have passed through counter 1 so that any count produced in counter 2 must also be a coincidence count if the efficiency of counter 1 is unity and if the circuit is losing no coincidences. Four readings are taken; S_2 is the single count in 2 with the source in place and S_{2B} with the source removed. C and C_B are the corresponding coincidence counts. The following relation, then, should yield some information as to loss of coincidences:

$$\frac{C - C_B}{S_2 - S_{2B}} = E_1 E_C \quad (2)$$

where E_1 is the efficiency of counter 1. If the efficiency of counter 1 is unity, then a direct determination of coincidence efficiency E_C is obtained. If $E_1 E_C$ is much less than unity, some effort should be made to obtain separate evaluations of E_1 and E_C . Since E_C varies with τ and E_1 does not, one could, by varying τ , determine whether or not $E_1 E_C$ remains constant. If $E_1 E_C$ remains constant as τ is increased, then one could conclude that E_1 and not E_C is much less than unity. Next, after measuring E_C , one should use the same two counters with the same voltages in taking coincidence data. Any coincidence rates taken may then be divided by E_C to get the true coincidence rate (after subtraction of the chance coincidence background).

The writer would like to point out that in β - β coincidence work the geometry of the counters should be so arranged that the counters may not "see" each other since scattering from one counter to the other would cause spurious coincidences.

EXPERIMENTAL RESULTS

Work was carried out recently to determine the effective conversion coefficient for the γ rays from Au^{198} monitors activated in the pile. Consider a gold source emitting N β rays and N γ rays, $N\alpha$ of which are internally converted (the very soft γ from Au^{198} may be neglected if an appreciable absorber is used) placed near two β counters. If the geometry factors are A_1 and A_2 (these factors include E_1 and E_2) the single counting rates should be given by:

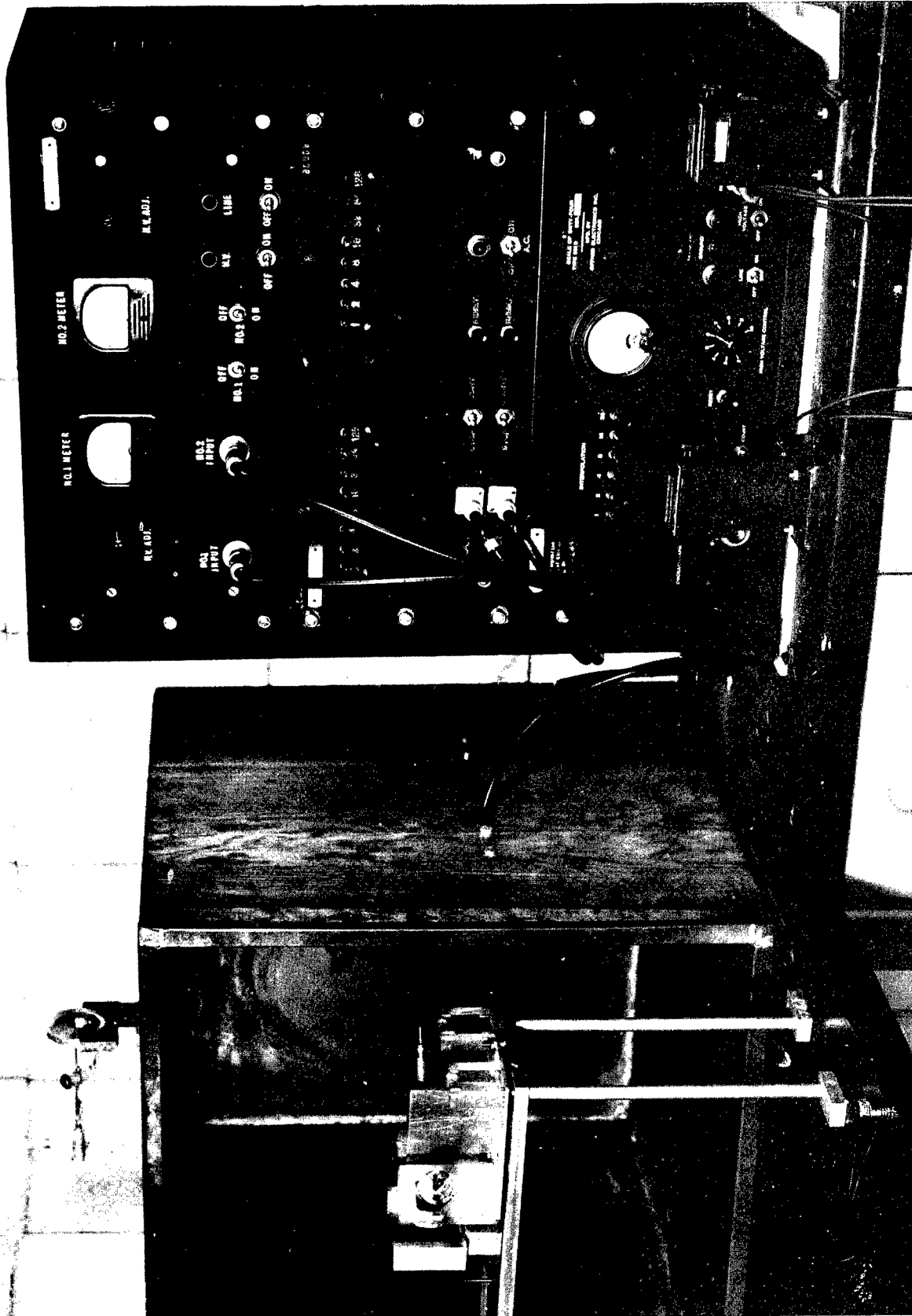

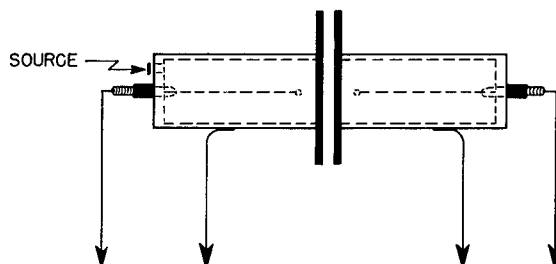

Figure 4. Special type mica-window counter.

$$S_1 = NA_1 + N\alpha A_1 - N\alpha A_1^2 \quad (3a)$$

$$S_2 = NA_2 + N\alpha A_2 - N\alpha A_2^2 \quad (3b)$$

The first terms represent counts due to β particles, the second those due to conversion electrons and the third those due to β particles and conversion electrons entering the same counter simultaneously. It is obvious that if N is to be determined from single counting rates as in the case of the Au flux monitor, then α , the conversion coefficient, must be known. Another relation is used for determining α . If one counts coincidences due to a conversion electron entering counter 1 or 2 at the same time a β particle enters counter 2 or 1, the coincidence rate should be:

$$C = 2N\alpha A_1 A_2 \quad (4)$$

Thus

$$\frac{C}{S_1} = \frac{2A_2 \alpha}{1 + \alpha - A_1 \alpha} \quad \text{and} \quad \frac{C}{S_2} = \frac{2A_1 \alpha}{1 + \alpha - A_2 \alpha} \quad (5)$$

so that if A_1 , A_2 , C , S_1 , and S_2 are measured, a value for α may be determined and, consequently, a value for N , the disintegration rate, may be determined. The value obtained for the effective conversion coefficient is 7%. $E_1 E_c$ of equation 2 was 0.94 during this run and τ was 6×10^{-7} sec. No attempt was made to separate E_c and E_1 . If E_1 were as low as 0.94, then there was no coincidence loss during the run, whereas, if E_1 were as high as unity, the coincidence loss would have been 6%. Therefore, an error of $\pm 3\%$ must be recognized (after increasing the measured value by 3%) due to the possibility of coincidence losses. Errors in measurement of A_1 and A_2 carry the total estimated error to approximately 10% so that the effective conversion coefficient for Au^{198} would be quoted at $7 \pm 1\%$.

Previously some coincidence work was done in connection with the Xe^{135} problem.⁷ It was felt that if active contamination in the xenon samples used were present (due to Hg vapor, etc.) after irradiation, erroneous conclusions might be drawn from single counting data as to the absorption cross section. A rough measurement was made in which it was found that Xe^{135} has a converted γ with a value for α of about 10%. Since the Xe^{133} present in the samples has a γ of very low conversion coefficient, and no contamination activities which could be thought of would give rise to coincidences, it was decided that the Xe^{135} problem would be run with both single counting and coincidence data. The ratio of the activities of two Xe^{135} samples before and after the irradiation of one of the samples was taken by both single counting and coincidence methods. The data taken gave very good agreement with the single counting data, indicating that the contamination of the samples measured was small. In measuring the ratio of the coincidence activities of two like sources the coincidence loss, if any, would be the same for both sample measurements and, therefore, need not be considered.

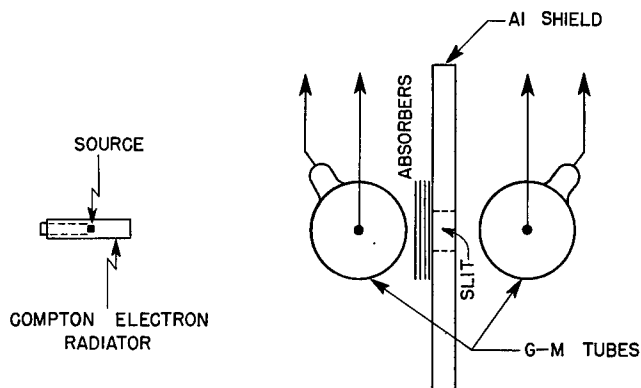

Figure 5.

Some work has been done here in the measurement of Compton-recoil energies by the absorption method with the coincidence circuit. Considerable disagreement was found in the literature as to the absorption curve for Al to be used for this work. Accordingly, it was decided to attempt to draw the appropriate curve by measuring a few γ sources of different energies which were fairly well known. The geometry is as shown in Figure 5. Using two tubular thin-walled counters, the Compton electrons from the radiator may give rise to coincidences by passing through both counters. Since the γ efficiency of the counter is less than 1%, the probability of both counters being discharged by one γ ray is very low. Absorbers are placed between the counters and a plot is made of coincidence rate against mg/cm^2 absorber. Since the e^- energy is well defined, a sharp break occurs in the absorption curve. The curves are dealt with as shown in Figure 6. The Al absorption curve which seems to fit the data is shown in Figure 7.

CONCLUSION

The development of a fairly dependable coincidence circuit has been outlined, and its uses and limitations have been pointed out. Values have been obtained for the conversion coefficients of Au^{198} and Xe^{135} . Also, an absorption curve for Compton-recoil electrons has been obtained as an aid to γ -ray energy measurements.

The writer expresses his gratitude to Paul W. Levy for his construction of counters and his suggested special counter, to L. A. Pardue for his help and advice, and to W. Bradley for his cooperation in the development of the coincidence circuit and its dual scaler. E. O. Wollan's experience with cosmic ray coincidence work has been especially helpful.

REFERENCES

1. Norling, Folke, Arkiv for Matematik, Astronomi Fysik, BD 27A. N:O 27.
2. Rossi, B., Nature 125:636 (1930).
3. Bradley and Epstein, Inst. Section Report No. 50299 Oct. 23, 1944.
4. Bradley, CP2426.
5. Echart and Shonka, Phys. Rev. 53:752 (1938).
6. Montgomery, C. G., Ramsey, Cowie, D. D. Montgomery, Phys. Rev. 56:635 (1939).
7. CP 2600.

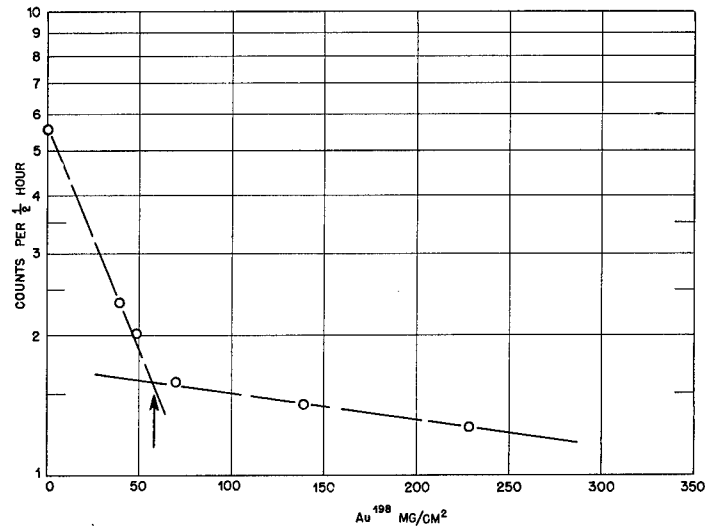

Figure 6. Al absorption of Compton recoils from the 0.42 Mev γ 's of Au¹⁹⁸ residual absorber was 94.7 mg/cm² end-point at 94.7 + 57.5 = 152.2 mg/cm².

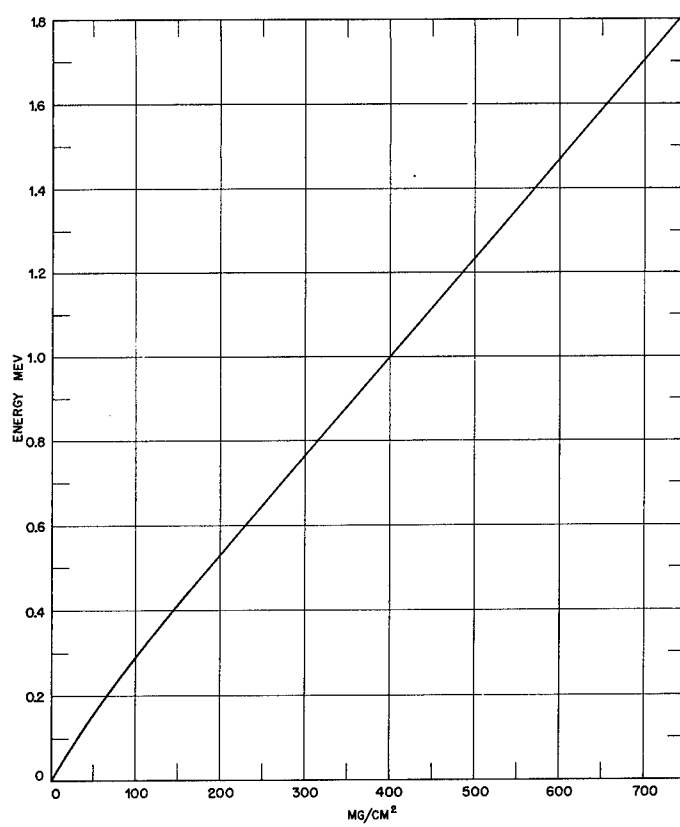

Figure 7. Compton recoil absorption curve for aluminum.

END OF DOCUMENT