

NATIONAL AIR INTELLIGENCE CENTER



RESEARCH ASSOCIATED WITH SINGLE GYROSCOPE DUAL
RING PLATFORM INERTIAL GUIDANCE SYSTEMS

by

Liu Shiduan

DDIC QUALITY INSPECTED 2



Approved for public release:
distribution unlimited

19970206 073

HUMAN TRANSLATION

NAIC-ID(RS)T-0301-96

2 December 1996

MICROFICHE NR:

RESEARCH ASSOCIATED WITH SINGLE GYROSCOPE DUAL
RING PLATFORM INERTIAL GUIDANCE SYSTEMS

By: Liu Shiduan

English pages: 13

Source: Cama, China Astronautics and Missilery Abstracts,
Vol. 3, Nr. 1, 1996; pp. 43-48

Country of origin: China

Translated by: SCITRAN
F33657-84-D-0165

Requester: Richard A. Peden, Jr.

Approved for public release: distribution unlimited.

THIS TRANSLATION IS A RENDITION OF THE ORIGINAL FOREIGN TEXT WITHOUT ANY ANALYTICAL OR EDITORIAL COMMENT STATEMENTS OR THEORIES ADVOCATED OR IMPLIED ARE THOSE OF THE SOURCE AND DO NOT NECESSARILY REFLECT THE POSITION OR OPINION OF THE NATIONAL AIR INTELLIGENCE CENTER.	PREPARED BY: TRANSLATION SERVICES NATIONAL AIR INTELLIGENCE CENTER WPAFB, OHIO
--	---

GRAPHICS DISCLAIMER

All figures, graphics, tables, equations, etc. merged into this translation were extracted from the best quality copy available.

RESEARCH ASSOCIATED WITH SINGLE GYROSCOPE DUAL
RING PLATFORM INERTIAL GUIDANCE SYSTEMS

Liu Shiduan

Translation of "Dan Tuo Luo Shuang Huan Ping Tai Guan Dao Xi Tong Yan Jiu"; Inertial Guidance and Instrumentation, No.3, 1995, pp 43-48

ABSTRACT This article puts forward, and, in conjunction with that, studies mixed inertial and geomagnetic navigation systems composed of single gyroscope dual ring inertial platforms and solid state geomagnetometers. In the article, discussion is made of system construction as well as operating principles. In depth study is made with regard to system mechanical lay out. In conjunction with this, analyses are completed of system accuracy with a view toward cruise missile flight status. Combined inertial/geomagnetic navigation systems are capable of supplying navigation and guidance information which is the same as that associated with inertial guidance systems. They are not only capable of providing longitude and latitude. They are, moreover, able to supply such information as surface (illegible) as well as attitude angles, and so on. Due to the fact that inertial platforms only make use of one gyroscope and two accelerometers and there is also no bearing stability circuitry, therefore, the structure is simple. Manufacture is easy, and volumes are small. Costs are low. Another obvious advantage associated with the systems in question is that there is no need to carry out azimuth alignment. Preparation times are very, very much shortened.

KEY WORDS Inertial navigation system Magnetic heading instruments Low cost guidance system Single gyroscope platform

I. INTRODUCTION

As everyone knows, inertial navigation is one type of advanced navigation system. It is strongly autonomous--capable of using continuous, complete, and highly precise methods to supply various types of navigation and guidance parameters. Numerous advantages make inertial navigation systems into pieces of key equipment associated with delivery vehicles. The most outstanding problem associated with inertial guidance systems is expensive prices. This shortcoming put a good number of users in terror of them for a long time, not daring to get involved with them. At the present time, various types of inertial navigation systems are in the midst of a phase of rapid development. Long strides associated with GPS have gradually changed inertial navigation systems in order to pursue set ups with high precisions as the primary development objective. Lowering system costs and reducing volumes has made

systems become acceptable to more users and even more important than at any time in the past.

Conventional platform type inertial guidance systems opt for the use of three ring or four ring platforms. The structure is complicated. Costs are high. Volumes are large. Reliability is bad. Quick connect strapdown type inertial navigation systems simplified the structure of systems, reduced volumes, and improved reliability. However, their requirements with regard to inertial components--in particular, gyroscopes--are very severe. System cost reductions are not clear. As a result, inside and outside China, great efforts have been put into research on platform structures that are comparatively simple for inertial navigation systems--for example, speed bearing platform inertial guidance systems and single axis stable strapdown inertial navigation systems [1]. This research has effectively resolved volume problems associated with inertial navigation systems. However, the degree of lowering in system costs is certainly not completely satisfactory. /44

At the present time, inside and outside China, geomagnetic instruments and technologies associated with compensating for the interference of magnetic fields have both reached comparatively high levels. The accuracies of magnetic course instruments are relatively high. Consideration is given to this factor and characteristics associated with pure inertial altitude channel error divergences. In conjunction with this, the current level associated with Chinese inertial components is looked at. Going through comparisons of various types of inertial guidance systems inside and outside China, this article puts forward mixed inertial navigation system designs composed of single gyroscope, dual ring inertial platforms and solid state geomagnetic instruments.

2. SYSTEM CONSTITUENTS AND OPERATING PRINCIPLES

The structures of mixed inertial/geomagnetic navigation systems are of two types. One type of structure among these is as shown in Fig.2.1.

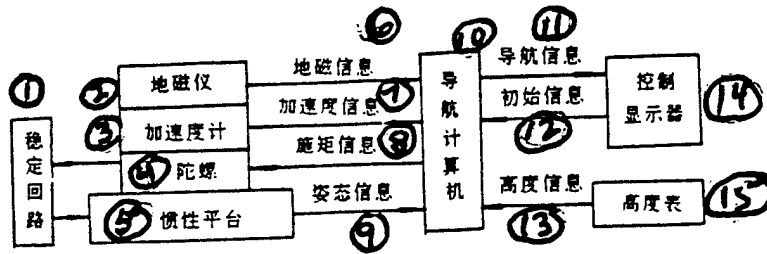

Fig. 2.1 One Mixed Inertial/Geomagnetic Navigation System Structure

Key: (1) Stabilization Circuitry (2) Geomagnetometer (3) Accelerometer (4) Gyroscope (5) Inertial Platform (6) Geomagnetic Information (7) Acceleration Information (8) Moment of Rotation Information (9) Attitude Information (10) Navigator Computer (11) Navigation Information (12) Initial Information (13) Altitude Information (14) Control Display (15) Altimeter

In Fig.2.1, geomagnetometers are installed on platforms. Option is made for the use of dual axis vector quantity geomagnetometers to measure two horizontal components associated with geomagnetic fields. On the basis of outputs, computers calculate platform course angles. This type of structure does not require that carrier bodies leave specialized installation sites for geomagnetometers. Course angle calculations are comparatively simple. However, error compensation technologies are complicated. Due to the fact that systems associated with this type of structure are very plentifully represented, this article will, therefore, focus its studies on them.

In this type of structural system, the inertial platforms used are dual ring platforms. They have two stabilization axes--roll and pitch. The specific structure is as shown in Fig.2.2.

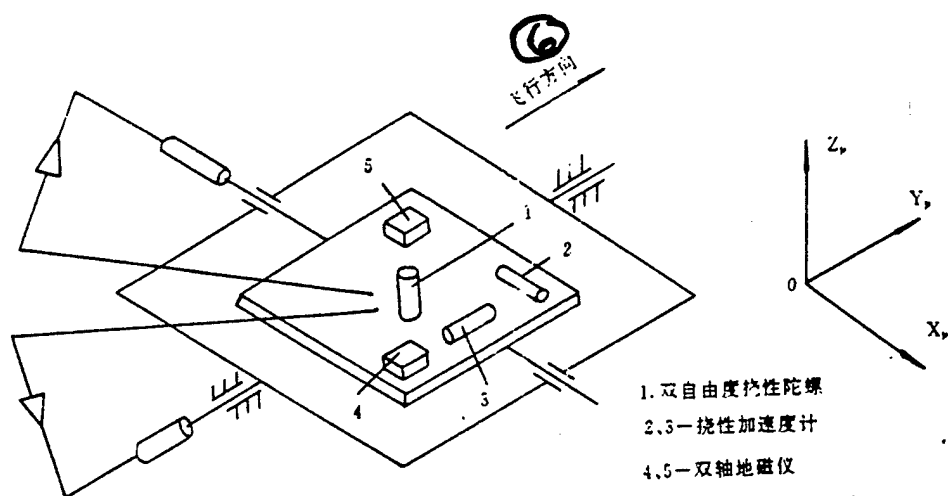

Fig 2.2 Inertial Platform Structure Schematic

Key: 1. Flexible Gyroscope with Dual Degrees of Freedom 2 and 3 Flexible Accelerometer 4 and 5 Dual Axis Geomagnetometer (6) Direction of Flight

Gyroscopes are installed vertically. The two measurement axes point, respectively, toward corresponding platform coordinate axes. The two accelerometers respectively measure accelerations associated with the directions of two mutually perpendicular horizontal coordinate axes along the carrier body platform, calculating out in real time various types of navigation parameters.

The systems in question possess the two important characteristics below.

1. Geomagnetometers with inexpensive prices and small volumes replace azimuth gyroscopes with expensive prices and comparatively large volumes.

2. Systems do not set up inertial altitude channels. Because of the fact that inertial altitudes need to be combined with altitude information associated with other equipment and are only capable of being made use of after that, and the combining will make systems produce redundancies, they are not advantageous to the lowering of system costs.

Compared to conventional one ring platforms, the system structures in question are very simple. This is the basic reason for system costs and volumes being reduced. Do to the fact that systems do not set up inertial altitude channels, as a result, they are not able to supply inertial altitude information. Besides this, navigation and guidance information provided by the systems is the same as that associated with pure inertial navigation systems.

3. SYSTEM EQUATION SET UPS

Coordinate Systems:

Systems opt for the use of northeastern celestial geographic coordinates to act as navigational coordinate system. Platform coordinate systems (see Fig.2.2) and geographical coordinate systems differ from each other by a course angle α .

Relative Force Equations:

Relative forces are accelerometer readings. System relative force equations are:

(3.1)

$$\begin{aligned} f_x^p &= \dot{V}_x^p + (2\Omega \cos\phi \cos\alpha + \omega_{cp}^x) V_x^p - (2\Omega \sin\phi + \omega_{cp}^y) V_y^p \\ f_y^p &= \dot{V}_y^p + (2\Omega \cos\phi \sin\alpha + \omega_{cp}^y) V_x^p - (2\Omega \sin\phi + \omega_{cp}^x) V_y^p \end{aligned}$$

Because of the fact that geographical coordinate systems are selected for navigation systems, it is, therefore, necessary to take relative forces and project them onto a geographical system. The projection equation is:

$$\begin{bmatrix} f_E \\ f_N \end{bmatrix} = \begin{bmatrix} \cos\alpha & -\sin\alpha \\ \sin\alpha & \cos\alpha \end{bmatrix} \begin{bmatrix} f_x^p \\ f_y^p \end{bmatrix} \quad (3.2)$$

In geographical systems, the system velocity equations are:

(3.3)

$$\begin{cases} \dot{V}_E = f_E + (2\Omega \sin\phi + \omega_z) V_N - (2\Omega \cos\phi - \omega_N) V_z \\ \dot{V}_N = f_N - (2\Omega \sin\phi + \omega_z) V_E + \omega_E V_z \end{cases}$$

In equations, Ω is the angular velocity associated with the spin of the earth. ϕ is geographical latitude. V_E and V_N are, respectively, carrier body velocities in an east direction and a north direction. ω_E , ω_N , and ω_z are, respectively, angular velocities associated with displacements in an east, north, and celestial direction. Speaking in terms of general situations, the influence of V_z on the calculation accuracies of V_E and V_N is comparatively small and can be ignored. As a result, equation (3.3) can be simplified to be:

$$\begin{cases} V_E = f_E - a_{BE} \\ V_N = f_N - a_{BN} \end{cases} \quad (3.4)$$

$$\begin{aligned} a_{BE} &= -(2\Omega \sin\phi + \omega_z) V_N \\ a_{BN} &= (2\Omega \sin\phi + \omega_z) V_E \end{aligned}$$

In equations, a_{BE} and a_{BN} are, respectively, back accelerations associated with east directions and north directions.

$$a_{BE} = -(2\Omega \sin\phi + \omega_z) V_N$$

$$a_{BN} = (2\Omega \sin\phi + \omega_z) V_E$$

The formula for calculating ground speed is:

$$V = \sqrt{V_E^2 + V_N^2} \quad (3.5)$$

Angular velocities associated with carrier body positions are also calculated in geographical systems. The formulae are:

$$\begin{cases} \omega_E = -\frac{V_N}{R_M} \\ \omega_N = \frac{V_E}{R_N} \\ \omega_z = \frac{V_E}{R_N} \operatorname{tg}\phi \end{cases} \quad (3.6)$$

In equations, R_M and R_N are, respectively, main curvature radii in meridian planes and principal planes. The formulae for calculating the latitude ϕ and longitude λ of the locations of carrier bodies are:

$$\begin{cases} \phi = -\omega_E \\ \lambda = \omega_N / \cos\phi \end{cases} \quad (3.7)$$

Platform Control Formulae
Control moments of rotation given to gyroscopes are composed of two parts. One part compensates for angular velocities associated with the spin of the earth. The other part compensates for positional angular velocities in order to maintain the platform level. They should be added to the corresponding gyroscope axis. As a result, added moments are realized in platform systems. It is necessary to take the two angular velocities described above and project them onto platform systems. The projection relationship is:

$$\begin{bmatrix} \omega_{ex} \\ \omega_{ey} \end{bmatrix} = \begin{bmatrix} \cos\alpha & \sin\alpha \\ -\sin\alpha & \cos\alpha \end{bmatrix} \begin{bmatrix} \omega_E \\ \omega_E + \Omega \cos\phi \end{bmatrix} \quad (3.8)$$

Course Angle Equations:
 Referring to Fig.2.2, geomagnetometers are installed along platform coordinate systems. Assuming that the horizontal component of geomagnetic fields is 1, when platforms turn through a counterclockwise angle α in a horizontal plane, the projections of 1 on the two platform coordinate axes H_x and H_y are nothing other than geomagnetometer outputs. Thus, compass course angles are:

$$\alpha = \text{arctg} \frac{H_x^p}{H_y^p} \quad (H_y^p \neq 0)$$

$$\alpha = \sin(H_x^p) \cdot 90^\circ \quad (H_y^p = 0) \tag{3.9}$$



Fig.3.1 Course Error Calibration Line and Block Chart

Key: (1) Magnetic Sensor (2) Compass Course (3) Compass Deviation Calibration (4) Magnetic Course (5) Magnetic Deviation Calibration (6) True Course

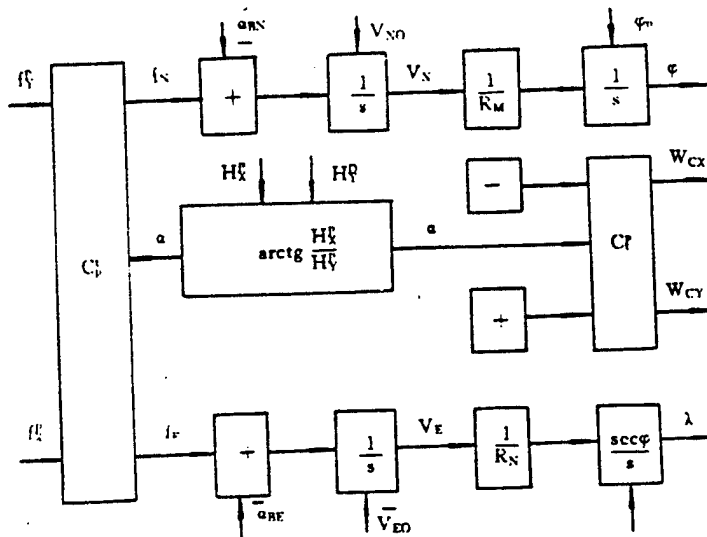

Fig.3.2 Inertial/Geomagnetic Mixed Navigation System Calculation Line and Block Chart

Here, the true value of α may not be consistent with main arctg function values. During actual programming, it is necessary to add in adjustments. In reality, compass magnetic and magnetic deviations exist between compass course angles and true course angles. It is necessary to apply calibrations. The principles of calibrations are as shown in Fig.3.1. As far as the specific methods are concerned, refer to Reference [4]. On the basis of the numerical models above, it is possible to draw up calculation line and block diagrams associated with mixed inertial/geomagnetic navigation systems, as shown in Fig.3.2.

4. SYSTEM ERROR ANALYSIS

With a view toward cruise missile flights, system error equations are as follows:

$$X = FX \quad (4.1)$$

In equations, $X = (\delta V_x, \delta V_y, \delta \varphi, \delta \lambda, \varphi_x, \varphi_y, \delta \alpha, \epsilon_x, \epsilon_y, V_x, V_y)^T$ (4.2)

F is a system error status matrix. The non zero elements are:

$$F_{1.1} = \frac{V_y}{R} \cos \alpha \operatorname{tg} \varphi;$$

$$F_{1.3} = -2\Omega \cos \varphi \cdot V_y - \frac{V_y}{R} (V_x \cos \alpha - V_y \sin \alpha) \sec^2 \varphi;$$

$$F_{1.7} = (V_x V_y \sin \alpha + V_y^2 \cos \alpha) \cdot \frac{\operatorname{tg} \varphi}{R};$$

$$F_{2.1} = 2\Omega \sin \varphi + 2 \frac{\operatorname{tg} \varphi}{R} (V_x \cos \alpha - V_y \sin \alpha);$$

$$F_{2.3} = 2\Omega \cos \varphi \cdot V_x + \frac{V_x \cos \alpha - V_y \sin \alpha}{R} \sec^2 \varphi \cdot V_x;$$

$$F_{2.7} = -\frac{V_x}{R} (V_x \sin \alpha \cdot \operatorname{tg} \varphi + V_y \cos \alpha);$$

$$F_{3.1} = \frac{\sin \alpha}{R};$$

$$F_{3.7} = \frac{V_x \cos \alpha - V_y \sin \alpha}{R};$$

$$F_{4.2} = \frac{\sin \alpha \sec \varphi}{R};$$

$$F_{4.7} = -\frac{V_x \sin \alpha + V_y \cos \alpha}{R} \sec \varphi;$$

$$F_{5.3} = -\Omega \sin \alpha \cdot \sin \varphi;$$

$$F_{5.7} = \Omega \cos \alpha \cos \varphi;$$

$$F_{6.1} = \frac{1}{R};$$

$$F_{6.5} = -\Omega \sin \varphi - \frac{\operatorname{tg} \varphi}{R} (V_x \cos \alpha - V_y \sin \alpha);$$

$$F_{6.9} = 1$$

$$F_{1.2} = -(2\Omega \sin \varphi + \frac{V_x}{R} \cos \alpha \operatorname{tg} \varphi)$$

$$F_{1.6} = -g$$

$$F_{1.10} = 1$$

$$F_{2.2} = -\frac{V_x \sin \alpha \operatorname{tg} \varphi}{R}$$

$$F_{2.5} = g$$

$$F_{2.11} = 1$$

$$F_{3.2} = \frac{\cos \alpha}{R}$$

$$F_{4.1} = \frac{\cos \alpha \sec \varphi}{R}$$

$$F_{4.3} = \frac{V_x \cos \alpha - V_y \sin \alpha}{R} \operatorname{tg} \varphi \cdot \sec \varphi$$

$$F_{5.2} = -\frac{1}{R}$$

$$F_{5.6} = \Omega \sin \varphi + \frac{\operatorname{tg} \varphi}{R} (V_x \cos \alpha - V_y \sin \alpha)$$

$$F_{5.8} = 1$$

$$F_{6.3} = -\Omega \cos \alpha \sin \varphi$$

$$F_{6.7} = -\Omega \sin \alpha \cos \varphi$$

/47

This article goes through solutions of matrix Riccati differential equations in order to obtain propagation characteristics associated with system errors. During calculations, statistical characteristics associated with various error quantities are as follows.

$$E(\delta V_{x0}^2) = E(\delta V_{y0}^2) = (0.1 \text{ m/s})^2$$

$$E(\delta \phi_0^2) = E(\delta \lambda_0^2) = (0.5')^2$$

$$E(\phi_{x0}^2) = E(\phi_{y0}^2) = (20'')^2$$

$$E(\delta \alpha^2) = (0.25^\circ)^2$$

$$E(\nabla_x^2) = E(\nabla_y^2) = (10^{-4} \text{ g})^2$$

$$E(\epsilon_x^2) = E(\epsilon_y^2) = (0.01^\circ/\text{h})^2$$

During simulations, flight time is 30 minutes. Calculation results are as shown in Fig.'s 4.1 - 4.6. In the Fig.'s, option is made for the use of international unified measurement units.

From simulation curves, it is possible to see that there are some increases associated with various types of errors as functions of elapsed time. The explanation for this is that system error propagation characteristics and inertial guidance systems are similar--with the existence of error accumulation phenomena. The speeds of growth in various types of errors are comparatively slow, clearly showing that precisions associated with short term system utilization are relatively high. After 30 minutes of flight, velocity errors δV_x and $\delta V_y < 2 \text{ m/s}$. Latitude errors $\delta \phi < 2.1'$. Longitude errors $\delta \lambda < 1.6'$. If deduction is made of the initial error $0.5'$, actual system latitude error is $\delta \phi < 1.6'$. Longitude errors $\delta \lambda < 1.1'$. Platform attitude errors ϕ_x and $\phi_y < 45.4''$. These data clearly show that accuracies associated with the systems in question are equivalent to inertial navigation systems.

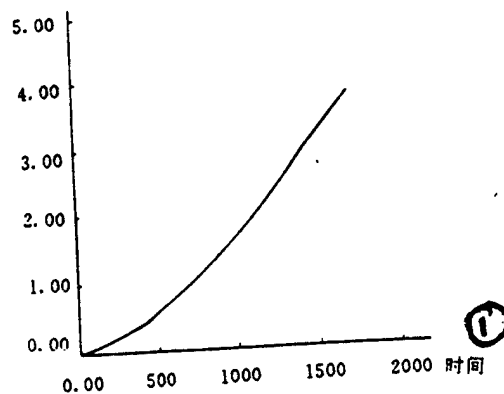

Fig.4.1 δV_x Mean Square Deviation Curve (1) Time

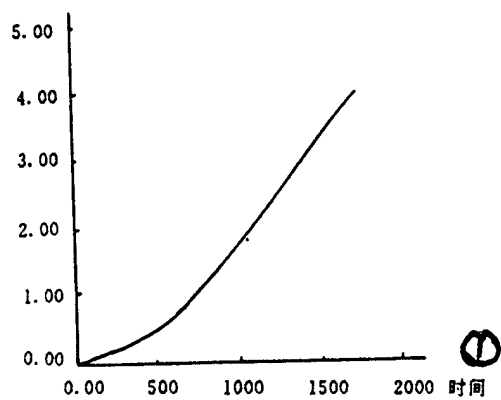

Fig.4.2 δV_y Mean Square Curve (1) Time

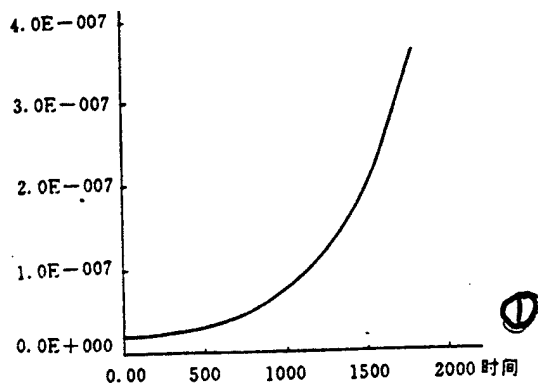

Fig.4.3 $\delta \phi$ Mean Square Curve (1) Time

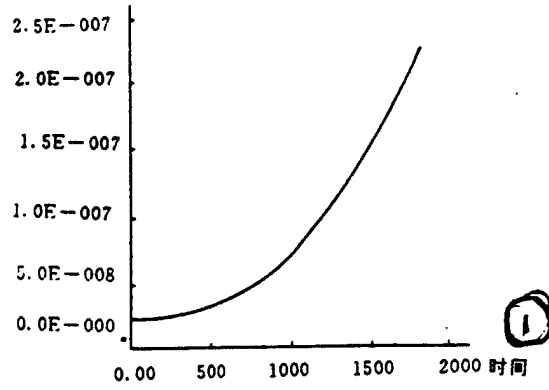

Fig.4.4 $\delta\lambda$ Mean Square Curve (1) Time

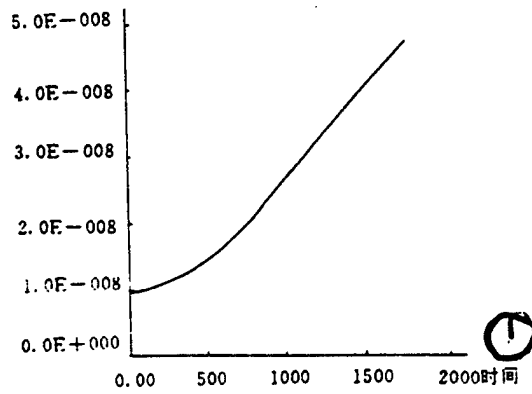

Fig.4.5 ϕ_x Mean Square Curve (1) Time

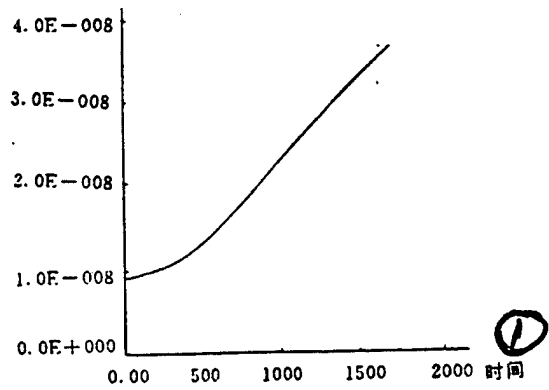

Fig.4.6 ϕ_y Mean Square Curve (1) Time

CONCLUSIONS

1. Comparing mixed inertial/geomagnetic navigation systems and conventional inertial navigation systems, costs are low, and volumes are comparatively small. They are autonomous types of navigation systems, capable of supplying the same various types of navigation and guidance information as inertial navigation systems. Systems possess intermediate accuracies. Their preparation times are relatively short. It is possible to say that the systems in question possess comparatively high performance/cost ratios. In a number of application realms, it is possible to use them in order to replace inertial navigation systems. They are a type of navigation system with extremely good development prospects.

2. Mixed inertial/geomagnetic navigation systems already have a good development foundation in China. The systems in question are based on the current development level of inertial components domestically. Requirements with regard to gyroscopes and accelerometers are not high. Dual ring platforms and velocity azimuth platforms in systems are very similar. The latter have already been developed successfully in China. In another area, magnetic course instruments constructed with the use of geomagnetometers and microcomputers are already better than 0.2 degrees. Domestically, all the conditions are in hand to develop experimentation and research associated with the systems in question.

REFERENCES

1. 任思聪, 实用惯导系统原理, 宇航出版社, 1988. 8.
2. Sheng Wu Liu et al. A High Accuracy Magnetic Heading System Composed of Fluxgate Magnetometers and Microcomputer, NAECON'1989.
3. K. B. R. Britting, Inertial Navigation Systems Analysis, 1971.
4. 郭秀中等, 陀螺仪理论及应用, 航空工业出版社, 1987.