Applied Computational Electromagnetics Society

DISTRIBUTION STATEMENT A

Approved for public release;
Distribution Unlimited

Newsletter
Volume 12 - No. 1
ISSN 1056-9170

19970226 019

March 1997

APPLIED COMPUTATIONAL ELECTROMAGNETICS SOCIETY (ACES)

NEWSLETTER

Vol. 12 No. 1

March 1997

TABLE OF CONTENTS

OFFICERS' REPORTS

President's Comments - Hal Sabbagh.	4
Annual Report - W. Perry Wheless, Jr.	5
Financial Report - Todd Hubing	6

COMMITTEE REPORTS

ACES Committees	7
Publications Report - W. Perry Wheless, Jr.	8
Conference Committee Report - Robert M. Bevensee	9

CEM NEWS FROM EUROPE - Pat Foster	10
Review of Research Activities in High Frequency Computational Electromagnetics in Germany - Ulrich Jakobus	12

PERSPECTIVES IN CEM

The 50th Anniversary of the Computer: The Dawning of a New Age - Ray Perez	15
--------------------------------------------------------------------------------------	----

THE PRACTICAL CEMist - Practical Topics in Communications - W. Perry Wheless, Jr.	19
Jim Breakall's offering	20

TUTORIAL

Introduction - James Drewniak	27
" Application of the Finite-Difference Time-Domain Method to Bioelectromagnetic Simulations"	28

BOOK REVIEW

"Parallel Computing, Theory and Practice" Ray Perez	58
------------------------------------------------------------------	----

ANNOUNCEMENTS

1998 ACES 14th Annual Review of Progress Call for Papers	60
1997 Conference Pre-Agenda	62
1997 Short Courses Information.	73
1997 ACES Conference Motel Listing	76
1997 NPS Campus Map	77
Call for Papers for ACES Special Issue on Computational Electromagnetics and High-Performance Computing	78
1997 ACES Conference Registration Form	79
Application for ACES Membership, Newsletter and Journal Subscription	80
Advertising Rates	81
Deadlines for the Submission of Articles	81

ACES NEWSLETTER STAFF

EDITOR-IN-CHIEF, NEWSLETTER

Ray Perez
Martin Marietta Astronautics
MS 58700, PO Box 179
Denver, CO 80201, U.S.A.
Phone: 303-977-5845
Fax: 303-971-4306
email:ray.j.perez@den.mmc.com

EDITOR-IN-CHIEF, PUBLICATIONS

W. Perry Wheless, Jr.
University of Alabama
P.O. Box 11134
Tuscaloosa, AL 35486-3008, U.S.A.
Phone: (205) 348-1757
Fax: (205) 348-6959
email:wwheless@ua1vm.ua.edu

ASSOCIATE EDITOR-IN-CHIEF

David B. Davidson
EE Department
University of Stellenbosch
Stellenbosch 7600, SOUTH AFRICA
Phone:+27 2231 77 4458 Work
Phone:+27 2231 77 6577 Home
Fax:+27 21 808 4981
e-mail:Davidson@firga.sun.ac.za

MANAGING EDITOR

Richard W. Adler
Pat Adler, Production Assistant
Naval Postgraduate School/ECE Dept.
Code ECAB, 833 Dyer Rd., Room 437
Monterey, CA 93943-5121, U.S.A.
Phone: 408-646-1111
Fax: 408-649-0300
email:rwa@ibm.net

EDITORS

CEM NEWS FROM EUROPE

Pat R. Foster
Microwaves and Antenna Systems
16 Peachfield Road
Great Malvern, Worc, UK WR14 4AP
Phone: +44 1684 5744057
Fax: +44 1684 573509
email:prf@maasas1.demon.co.uk

TECHNICAL FEATURE ARTICLE

Andy Drozd
ANDRO Consulting Services
PO Box 543
Rome, NY 13442-0543 U.S.A.
Phone: (315) 337-4396
Fax: (314) 337-4396
e-mail:androl@aol.com

THE PRACTICAL CEMIST

W. Perry Wheless, Jr.
University of Alabama
P.O. Box 11134
Tuscaloosa, AL 35486-3008, U.S.A.
Phone: (205) 348-1757
Fax: (205) 348-6959
e-mail:wwheless@ua1vm.ua.edu

MODELER'S NOTES

Gerald Burke
Lawrence Livermore National Labs.
Box 5504/L-156
Livermore, CA 94550, U.S.A.
Phone: (510) 422-8414
Fax: (510) 422-3013
e-mail:Burke2@llnl.gov

PERSPECTIVES IN CEM

Melinda Piket-May
University of Colorado at Boulder
ECE Dept., CB425
Boulder, CO 80309-0425
Phone: (303) 492-7448
Fax: (303) 492-5323
e-mail:mjp@boulder.colorado.edu

TUTORIAL

James Drewniak
University of Missouri-Rolla
Dept. Electrical Engineering
221 Engineering Res. Lab.
Rolla, MO 65401-0249 U.S.A.
Phone: (314) 341-4969
Fax: (314) 341-4532
e-mail:drewniak@ee.umar.edu

ACES JOURNAL

EDITOR-IN-CHIEF

Duncan Baker
EE Department
University of Pretoria
0002 Pretoria, SOUTH AFRICA
Phone: +27 12 420 2775
Fax: +27 12 43 3254
e-mail:duncan.baker@ee.up.ac.za

ASSOCIATE EDITOR-IN-CHIEF

Adalbert Konrad
ECE Department
University of Toronto
10 King's College Road
Toronto, Ontario, CANADA M5S 1A4
Phone: (416) 978 1808
e-mail:konrad@power.ele.utoronto.ca

NEWSLETTER ARTICLES AND VOLUNTEERS WELCOME

The ACES Newsletter is always looking for articles, letters, and short communications of interest to ACES members. All individuals are encouraged to write, suggest, or solicit articles either on a one-time or continuing basis. Please contact a Newsletter Editor.

AUTHORSHIP AND BERNE COPYRIGHT CONVENTION

The opinions, statements and facts contained in this Newsletter are solely the opinions of the authors and/or sources identified with each article. Articles with no author can be attributed to the editors or to the committee head in the case of committee reports. The United States recently became part of the Berne Copyright Convention. Under the Berne Convention, the copyright for an article in this newsletter is legally held by the author(s) of the article since no explicit copyright notice appears in the newsletter.

BOARD OF DIRECTORS					
EXECUTIVE COMMITTEE					
Harold A. Sabbagh, President		Todd Hubing, Treasurer			
Pat Foster, Vice President		Richard W. Adler, Exec. Officer			
W. Perry Wheless, Jr., Secretary					
DIRECTORS-AT-LARGE					
Duncan C. Baker	1997	Pat Foster	1998	John Brauer	1999
Edmund K. Miller	1997	Todd Hubing	1998	Harold Sabbagh	1999
Andrew F. Peterson	1997	Adalbert Konrad	1998	Perry Wheless, Jr.	1999

NEEDED: ADVERTISING AND REPORTS EDITOR

If interested, please contact :

Ray Perez
Martin Marietta Astronautics
MS 58700, PO Box 179
Denver, CO 80201
Phone: 303-977-5845
Fax: 303-971-4306
email:ray.j.perez@den.mme.com

OFFICER'S REPORTS

PRESIDENT'S COMMENTS

My colleagues at Sabbagh Associates helped me celebrate my sixtieth birthday two days ago by inflating and suspending sixty balloons from the ceiling. The process by which we attached the balloons to the ceiling is well known to all CEM'ists; it goes by the name of static-electricity, and is achieved by rubbing the balloon on the carpet, or your sweater, or hair, or something equivalent, and then holding it to the acoustic tiles in the ceiling. We have discovered that some hair works better than others, but we have not yet computed the differences. My secretary is so skilled at suspending balloons from the ceiling, that she now qualifies as a SEM'ist (Static ElectroMagneticist). Yes, I know that there is no Magnetism in Static Electricity (at least for those of us who are stationary), but you get the point.

All the balloons are on the floor, now, which proves, once again, that capacitors will discharge sooner or later, and when I leave my desk after writing this note, I am likely to hear a few snap, crackle, and POPS, unless I tread very carefully.

When people ask me what it's like to be 60 years old, I simply remind them of the alternative, and we all smile. Nor is there any satisfactory alternative to being at ACES'97 in Monterey. Eric Michielssen and his crew have put together an excellent technical program. Hope to see you there.

Our good friend and colleague, Ken Siarkiewicz, was recently elected to the grade of IEEE Fellow. His citation reads, 'For contributions to the development and promotion of general electromagnetic analysis models for military and civilian systems.' ACES supported Ken's nomination, so I know that you will all join me in congratulating him.

Hal Sabbagh
Sabbagh Associates, Inc.

THE APPLIED COMPUTATIONAL ELECTROMAGNETICS SOCIETY, INC.

NOTICE OF THE ANNUAL BUSINESS MEETING

Notice is hereby given that the annual business meeting of the Applied Computational Electromagnetics Society, Inc. will be held on Tuesday 18 March 1997, in 102 Glasgow Hall at the Naval Postgraduate School, Monterey, CA. The meeting is scheduled to begin at 7:30 AM PST for purposes of:

1. Receiving the Financial Statement and Treasurer's Report for the time period ending 31 December 1996.
2. Announcement of the Ballot Election of the Board of Directors.

By order of the Board of Directors
Perry Wheless, Secretary

ANNUAL REPORT 1996

As required in the Bylaws of the Applied Computational Electromagnetics Society, Inc. a California Nonprofit Public Benefit Corporation, this report is provided to the members. Additional information will be presented at the Annual Meeting and that same information will be included in the July Newsletter for the benefit of members who could not attend the Annual Meeting.

MEMBERSHIP REPORT

As of 31 December 1996, the paid-up membership totaled 482, with approximately 39% of those from non-U.S. countries. There were 10 students, 78 industrial (organizational) and 394 individual members. The total membership has increased by 3% since 1 Jan 1996, with non-U.S. membership increasing by 6%.

Perry Wheless, Secretary

MEMBERSHIP RATES EFFECTIVE 1 APRIL 1996			
AREA	INDIVIDUAL SURFACE	INDIVIDUAL AIRMAIL	ORGANIZATIONAL (AIRMAIL ONLY)
US & CANADA	\$65	\$65	\$115
MEXICO,CENTRAL & SOUTH AMERICA	\$68	\$70	\$115
EUROPE FORMER USSR TURKEY SCANDINAVIA	\$68	\$78	\$115
ASIA, AFRICA, MIDDLE EAST, PACIFIC RIM	\$68	\$85	\$115

1996 FINANCIAL REPORT

ASSETS

BANK ACCOUNTS	1 JAN 1996	31 DEC 1996
MAIN CHECKING	31,092	13,957
EDITOR CHECKING	3,002	1,797
SECRETARY CHECKING	4,039	6,836
SAVINGS	317	101
HIGH RATE SAVINGS	-	41,541
CREDIT CARD	57,680	6,683
CD #1	12,304	\$0
CD #2	12,304	\$0
CD #3	\$0	10,457
CD #4	\$0	10,476
CD #5	\$0	10,481
CD #6	<u>\$0</u>	<u>10,481</u>
TOTAL ASSETS	\$120,738	\$112,810

LIABILITIES: \$0

NET WORTH 31 December 1996: \$112,810

INCOME

Conference	57,023
Short Courses	14,975
Publications	4,330
Membership	24,750
Software	812
Interest & misc.	<u>8,670</u>
TOTAL	\$110,560

EXPENSE

Conference	41,998
Short Courses	8,540
Publications	25,321
Software	726
Services (Legal, Taxes)	1,376
Postage	16,175
Supplies & misc.	<u>24,308</u>
TOTAL	\$118,444

NET DECREASE FOR 1996 \$7,928

In 1995 we enjoyed a net gain of \$41,866. In 1996 the net decrease was \$7,928. The differences were due to lack of conference sponsorship, lower conference attendance and increased publication and postage costs, and increased conference expenses.

Todd Hubing
Treasurer

PERMANENT STANDING COMMITTEES OF ACES INC.

COMMITTEE	CHAIRMAN	ADDRESS
NOMINATIONS	Adalbert Konrad	University of Toronto ECE Department 10 King's College Road Toronto, ON, CANADA M5S 1A4
ELECTIONS	Pingjuan Werner	Penn State University 321 Oakley Drive State College, PA 16803
FINANCE	Andrew Peterson	Georgia Institute of Technology School of ECE Atlanta, GA 30332-0250
WAYS & MEANS	Pat Foster	Microwaves & Antenna System 16 Peachfield Road Great Malvern, Worc, UK WR14 4AP
PUBLICATIONS	Perry Wheless	University of Alabama P.O. Box 11134 Tuscaloosa, AL 35486-3008
CONFERENCE	Robert Bevensee	BOMA Enterprises PO Box 812 Alamo, CA 94507-0812
AWARDS	John Brauer	The MacNeal Schwendler Corp. 4300 W. Brown Deer Rd., Suite 300 Milwaukee, WI 53223-2465

MEMBERSHIP ACTIVITY COMMITTEES OF ACES INC.

COMMITTEE	CHAIRMAN	ADDRESS
CODE USER GROUP	Russell Taylor	McDonnell Douglas Helicopters 5000 E McDowell Rd. Mesa, AZ 85205
SOFTWARE EXCHANGE	Atef Elsherbeni	Univ of Mississippi Anderson Hall, Box #13 University, MS 38677
SOFTWARE PERFORMANCE STANDARDS	Donald Pflug	Rome Laboratory/ERST 525 Brooks Rd. Griffiss AFB, NY 13441-4505
HISTORICAL	Robert Bevensee	Boma Enterprises PO Box 812 Alamo, CA 94507-0812

COMMITTEE REPORTS

ACES PUBLICATIONS

The subject of this Publications Report is electronic preparation and distribution of materials. I expect that most of our readers are now familiar with the recent special issue of IEEE Transactions on Education, which seems to have stimulated a considerable level of interest, both within and outside IEEE. To many ACES members, the immediate vision evoked when this topic arises for discussion is the dissemination of entire Journal and Newsletter issues to the ACES membership by electronic means. That is certainly part of the consideration, but there are numerous other preliminary mechanics which must be addressed and mastered prior to dealing with the matter of total document delivery by an electronic vehicle. The public indications from IEEE all point to the year 2000 as their target for an effective, comprehensive implementation of electronic methods; present experiments are apparently just that. To facilitate a corresponding start along the learning curve for ACES Publications, it appears appropriate that we should also begin our own experimentation during 1997.

In the case of the ACES Journal, the first step is the preparation and delivery of draft manuscripts for peer review processing. It is reasonable to envision that an electronic process should be electronic throughout, and that first applies to manuscripts. This immediately raises the question - how many ACES members (and prospective non-ACES member authors) have the capability for posting a document in electronic form so that Duncan Baker, the ACES Journal Editor-in-Chief, and designated reviewers can access it by Internet for study and processing? Some folks, by the grace of God, are generously endowed with computer equipment and software facilities and, to hear them talk, everyone is in this elevated state of empowerment. A limited personal survey, however, suggests that simply is not true. When the ACES Journal adopted format guidelines about three years ago, it was suggested that such an action would reduce interest among authors in publishing with ACES. In fact, paper submissions have declined, but there have been zero complaints regarding the format guidelines from authors and, so, there is no evidence that slightly increasing the preparation burden of authors has been adverse for ACES. One might argue that a call for authors to post manuscripts for Internet access is similar. The incentive for change might be that authors will have their papers reviewed much faster, so that final publication of accepted papers occurs at an accelerated pace. But, if we initiate such an endeavor, can we successfully "sell" prospective authors on the assurance that traditional submissions are still equally valued and respected? In this case, there may be a real possibility that authors will be repelled by the notion of further escalation of effort on their part. There is a perception by many that we are rapidly entering an era of computer elitism. This perception, whether imaginary or well-founded, still produces the effect of resistance. Hence, it is clear that ACES Publications must tread lightly, with a high degree of sensitivity toward authors, as we move toward the inevitable future.

Additional intermediate requirements of electronic publishing will be addressed in future reports. Jumping beyond those issues, assume that, at some point in the future, ACES has arrived at the capability for electronic distribution of the Journal and Newsletter. Access time via Internet is likely to be a matter for serious concern. I have been scouring the Internet recently for equipment and component literature in connection with a research project; the process has been extremely labor-intensive and time-consuming, and the signs of heavy Internet loading are apparent. Duncan Baker has pointed out that the problem is even greater internationally, where one must expend vast amounts of time to download materials which are graphics intensive. Because the ACES membership is approximately 40% outside the U.S., and the international component of the society is growing rapidly, this is an issue which demands careful consideration. Given the foreseeable Internet capacity trends, dynamic replication of any "central" ACES Publications site will certainly be necessary to satisfy the special requirements of our international members, and it is not clear that even that measure will be sufficient.

Finally, please note that CD distribution of ACES Publications has also been discussed among the Publications Committee members. There is interest in archiving the first twelve years of the ACES Journal and Newsletter on CD, but an economical means of accomplishing that goal has not been identified. If you

have any knowledge of companies which provide such a service for low-volume CD production, please let me know. Similarly, if you have special expertise in this area, and are interested in working on such a special project, contact me at your earliest convenience.

This report is not to address ACES strategy or solutions in the area of electronic publishing, but to make the membership aware that the matter is under consideration. ACES Publications will evolve appropriately in this direction, but in measured steps which are designed to serve the mission of information dissemination in a way that clearly benefits ACES members. We seek to keep pace with the changing times, but in an effective manner which resists the hasty embrace of trendy approaches. Your input and suggestions are welcome, and you are especially invited to discuss these matters with members of the Publications Committee at the ACES 97 conference in Monterey in March.

Submitted by
W. Perry Wheless, Jr., Chair
ACES Publications Committee

CONFERENCE COMMITTEE

This Committee has been overseeing the preparations for the ACES' Annual Review in March, 1997, and the Penn State Fall 1997 Short Course/Workshop, spearheaded by James Breakall.

The Committee has advocated (1) certain requirements for short course instructors and (2) a Student Annual Review Best-paper Prize, (3) helped review some of the abstracts of papers submitted to the '97 Review, (4) helped clarify the page charge rules for Review authors, and (5) helped formulate policy for the Russian attendees at the '97 Review.

As a result, the short course instructors are required to make copies of essentially all course outlines and essentially all vignettes available to the students, with penalties for non-compliance. The Student best-paper Prize, suggested by Patricia Foster, will consist of (a) \$200 cash, (b) a free short course at the '97 Review, and (c) free registration for the '98 Review. The page charge rules are outlined in the registration material sent to the authors of Review '97 papers. The Review '97 rules for the Russian attendees are the same as for the others, except that they are granted reduced registration fees.

The Committee has also reviewed the Preliminary Agenda for the '97 Review. Chairman will consult the membership and reduce its number to increase viability. The reduced Committee will be presented at the Annual Review in March.

Robert M. Bevensee, Chairman

CEM NEWS FROM EUROPE

Organised by Pat Foster, MAAS, UK

A workshop on Antenna Design Tools was held at ESTEC¹, Noordwijk, Holland in October 1996 and was organized by Dr. Marco Sabbadini of the Antenna Department, ESTEC. Many of the presentations given were on work carried out under contract to ESTEC.

The program, **ESAGTD**, has been developed for a UNIX Workstation by Matra Marconi and TICRA to deal with the problem of TT&C antennas on spacecraft where reflections, diffractions and blockage caused by the spacecraft structure and the large reflectors for Communications disturb the radiation pattern of the TT&C antenna which has a very wide beam. The geometry is formed from a library of shapes, triangles, truncated cones and so on. A very complex library of configurations is created for each spacecraft, for example, folded/unfolded solar panels can be specified.

Multiple interactions such as edge diffraction/edge diffraction are allowed. The interactions to be used are chosen from a library. Corner diffractions are not included nor are any creeping rays allowed although reflections from curved surfaces are included.

The radiation patterns in the near and far field are found by forward ray tracing. There are some approximations when a reflection is near an edge in a surface when edge diffraction replaces the reflection. Rays can be shown graphically for a specified output direction or point. Inter-antenna coupling can also be computed.

The **Antenna Design Framework** has been designed and written by IDS of Italy (1 million lines of C code). The project was started in 1992 and currently Version 2 should be released as a beta version in February 1997. The idea is to provide a uniform processor to handle a number of antenna design programs with them all using the same input geometry CAD files. The database program ORACLE is used. ADF is essentially a controller and carries out no electromagnetic computations of its own.

The demonstration showed the operation of the ADF to compute radiation patterns of a reflector antenna. The demo used a Sun Classic operating Solaris 2.3 and two PENTIUMs using WINDOWS NT to form a network. The graphics (CAD package) was from Bentley Microstation. A number of programs are under development for use with ADF including a diffraction program based on the Incremental Theory of Diffraction from the University of Siena.

Other programs include those for FDTD, BEM, IE tools from Thomson-CSF which can be used to design antennas including printed antennas and corrugated horns. A multilayer printed antenna (**TRIPATCH**) has been developed by the University of Lausanne. In addition, there are two optimiser programs. One is a standard optimiser and the other uses genetic algorithms. These both are controlled by ADF.

¹ ESTEC=Technical Centre for the European Space Agency

Aerospatiale gave a presentation on their commercial software which appears to require a CRAY (J916). They have an EMC package and a package (**ASERIS**) for designing antennas which has several components, FDTD, BEM etc. This includes a program using Finite Difference for dealing with EMC problems in multiple cable runs.

Several new developments are available from TICRA including COBRA (Contoured Beam Radiation Antenna) and **GRASP8** and their interfaces with ADF. GRASP* has been developed to allow an interface to ESAGTD.

The University of Leuven has developed **MAGMAS**, a Multilayer printed circuit and antenna package. It uses a mixture of MoM and a propagating wave (Expansion Wave Concept) which includes coupling when the elements of the antenna are more than 0.2 or 0.3 wavelength apart. The dielectric layers are infinite in horizontal extent so that radiation from edges or from terminated surface waves is neglected. The radiation patterns of an array are not therefore accurate more than 30.0 degrees from boresight.

IMST (L Baggen) gave an interesting short talk on there FDTD program which is called **EMPIRE**. They use AUTOCAD to generate the structure (if not already available from the mechanical designers. They have written an automatic mesher. They have cuboid cells which need not be of the same size and need not be cubical. The maximum ratio is probably 50:1. They do run it on a Silicon Graphics machine or a SparcStation. There is no wire treatment. They do have a considerable ability to excite waveguides and specific modes propagating in one direction can be specified. This appears to be an extremely professional suite of programs.

Spar Space Systems talked about an **Advanced Beam Feed Network** optimiser how to build a squarax network using COBRA/GRASP to design a multiple beam reflector for shaped coverage. It includes a sensitivity analysis et cetera.

This was an extremely useful workshop illustrating the breadth of programming in antenna and related topics now available in Europe. It ended with a round table discussion on the current status and needs of antenna CEM for space.

Review of Research Activities in High Frequency Computational Electromagnetics in Germany

Ulrich Jakobus

Institut fuer Hochfrequenztechnik, University of Stuttgart
Pfaffenwaldring 47, D-70550 Stuttgart, Germany
Phone/Fax +49 711 685 7420/7412, E-Mail jakobus@ihf.uni-stuttgart.de

Introduction

The present contribution aims at summarizing the work performed in the area of computational electromagnetics (CEM) in Germany. Emphasis has been placed on methods applicable to high frequency problems, mainly for solving radiation and scattering problems. Methods intended for low frequency or static applications will not be considered in the following.

Mentioned are only those groups that are actively involved with code development and research in CEM. There are also numerous other groups which mainly use these CEM tools for an application oriented research and development, e.g. for the design of new antenna concepts or for the investigation of mobile telephones radiating close to the human head.

The author initially tried to give a complete and comprehensive survey. There are, however, so many institutions and groups involved with different aspects of CEM in Germany that in order to keep this summary relatively short, a rather severe selection has been inevitable. Some numerical techniques with less significance for the solution of general electromagnetic radiation and scattering problems have therefore been omitted.

Finite Difference Time Domain (FDTD)

The FDTD method and also its variant, the FIT (Finite Integration Theory) which is based on the integral form of Maxwell's equations as opposed to the usually applied differential form, are widely employed in Germany.

A commercially available electromagnetic field simulator called MAFIA (Maxwell Finite Integration Algorithm) has been developed by a group around Weiland at the University of Darmstadt. This mature product has a very wide range of application from accelerator physics to electrostatic and -dynamic problems. Only recently the code has been extended to deal with acoustic problems, too.

Another group at the IMST (Institut fuer Mobil- und Satellitenfunktechnik, Kamp-Lintfort) around Wolff has developed a FDTD code as well, which shall be commercialized in the near future under the name EMPIRE (Electromagnetic Simulator for Packages, Interconnects, Radiators and Waveguide Elements). They have incorporated a near- to far-field transformation and the PML absorbing boundary condition. EMPIRE uses AutoCAD and Excel as pre- and postprocessor, respectively.

Apart from these two institutions working on a quite general FDTD formulation and implementation, there are several other groups, e.g. at the Microwave Department of the University of Bremen (Arndt et al.), which concentrate on an application of the FDTD to more specialized problems, e.g. waveguiding structures.

Finite Element Technique (FEM)

The FEM has found a wide application in Germany for electrostatic, magnetostatic as well as for low frequency problems such as electrical machines. Several groups are involved with code development for these applications. Especially the coupling of FEM with the boundary element method (BEM) is a current topic of research (e.g. Kost at the University of Cottbus).

However, for high frequency applications, the author is aware of only some work performed in Wuppertal (Eibert, Hansen) and Paderborn (Griese), where they also try to combine FEM and the surface integral equation technique to model planar circuits on layered structures.

Transmission Line Matrix Method (TLM)

Russer with his group at the Technical University of Munich and at the Ferdinand-Braun-Institute in Berlin concentrate on the TLM for an application to simulations of e.g. dielectric, anisotropic or lossy media in planar structures or of coplanar waveguides. They are also investigating the distributed simulation in a parallel computing environment.

Multipole Analysis

At the University of Bochum progress has been achieved in the last years concerning the spherical multipole analysis in sphero-conal coordinates by Blume, Klinkenbusch and their co-workers. Electromagnetic fields are expanded using solenoidal solutions of the homogeneous vector Helmholtz equation as basis functions, and then the boundary conditions are used to solve for the unknown expansion coefficients. This technique has, for example, been applied to compute the radar cross section of a semi-infinite elliptic cone.

Method of Moments (MoM)

There are several groups in Germany working on the integral equation technique. Computer codes based on the MoM with an electric field integral equation have been developed at the University of Hamburg-Harburg (program CONCEPT by Bruens, Mader, Singer), at the University-GH Paderborn (by Griese, Sabath, Oeing et al.) and at the University of Stuttgart (program FEKO by Jakobus, Landstorfer). There are some differences concerning the implementation and some of the programs also offer a combination with other numerical techniques, see below in the section Hybrid Methods. Furthermore, the two programs CONCEPT and FEKO allow the modeling of arbitrarily shaped dielectric bodies by applying surface and volume equivalence principles. Currently some work is in progress in order to exploit parallelism of the MoM for an execution on massively parallel supercomputers or on clusters of connected workstations.

Some error criterions for the MoM have been proposed by Blaschke et al. at the Technical University of Aachen.

Spectral Domain Approach

Microstrip and coplanar circuits are analyzed by Aroudaki, Vaupel and Hansen (University of Wuppertal, formerly Bochum) in the spectral domain using higher order expansion functions. This allows nonuniform meshing strategies with an improved current description. A combination with fast system matrix computation methods and the use of special matrix fill techniques leads to a drastic reduction in the computational effort.

Splitt (Fachhochschule Kiel) has also developed a computer program MultiStrip to analyze microstrip patch antennas on substrates in the spectral domain with the dyadic Green's function for grounded multilayered dielectric slabs.

At the Technical University of Munich (Detlefsen) and at the University of Duisburg (Wolff), the spectral domain approach is used for instance to compute the radiation pattern of planar leaky wave-antennas or to analyze coplanar circuits.

Method of Lines (MoL)

Pregla and his co-workers from the University of Hagen are involved in the development of the MoL and the related Beam Propagation Method (BPM) for cartesian and spherical coordinates. They successfully applied this technique to multilayered waveguides used in integrated microwave and millimeter wave circuits, but also to antenna problems such as dipole antennas, conical horns, or various kinds of planar antennas.

High Frequency Asymptotic Techniques

At the DLR (Deutsche Forschungsanstalt fuer Luft- und Raumfahrt) in Wessling the scattering of metallic objects has been analyzed by asymptotic techniques for the higher frequency range. Some tools have been developed to compute the mono- and bistatic radar cross section with Physical Optics (PO) or with the Physical Theory of Diffraction (PTD).

The uniform theory of diffraction (UTD) has been implemented by several groups (e.g. Wiesbeck et al. at the University of Karlsruhe or Gschwendtner, Woelfle et al., University of Stuttgart) in computer codes for the field strength prediction and to model the propagation of electromagnetic waves, either in terrestrial or urban areas, or in an indoor environment.

By the multipole analysis (see above) combined with an appropriate Euler summation technique, Blume et al. (University of Bochum) succeeded in deriving a new diffraction coefficient for the semi-infinite circular cone.

Zhu and Landstorfer (University of Stuttgart) have numerically determined diffraction, slope-, and multiple-diffraction coefficients of impedance wedges by the method of parabolic equation (PE). They apply PE and UTD to deal with wave propagation in complex environments.

Hybrid Methods (HM)

Hybrid methods try to combine the advantages of two or more numerical techniques into a new, superior formulation. One possible combination of FEM and BEM has already been mentioned above.

Two groups have developed hybrid methods combining the MoM with asymptotic techniques to reduce memory and CPU time for electrically large scattering problems. At the University of Dresden a group around Gonschorek (formerly with the University of Hamburg-Harburg) is combining the MoM with diffraction theory (UTD). At the University of Stuttgart, Jakobus and Landstorfer also pursue a hybrid approach in combining the MoM with asymptotic current expansions (PO, Fock, fringe currents) and also with the UTD.

Inverse Scattering

Some groups in Germany are active in the area of inverse problems. For instance at the University of Kassel (Langenberg et al.), they deal with microwave imaging and inverse scattering by linear as well as nonlinear reconstruction schemes. An improvement in the accuracy of reconstructing conducting surfaces has been achieved by extending the scalar inverse scattering theory to the vector case.

Conclusion

An attempt has been made to present the German research activities in the area of high frequency CEM to the interested international reader of this Newsletter.

PERSPECTIVES IN CEM

The 50th Anniversary of the Computer: The Dawning of a New Age

Ray Perez

The existence of ACES and for that matter, the existence of any engineering or scientific society devoted to the advancement of computational methods is mostly owed to the role of computers. This article is based on the recollection of a series of readings done by the author on the subject. The objective is to provide a history about the technological development of the computer and the information age. Some of us may be too young to remember. Some of us may have already forgotten..

Those knowledgeable in the history of technology have categorized the birth of the computer as the dawn of a "third wave", known as the information age. The first wave was said to be the nascent of agriculture about 10,000 years ago and the second wave was the industrial revolution of the 18th century. The era of computers has not only had a major impact in the professional life of those who use computers everyday, but also on every member of society. From the computational point of view, the roots of the computer could go back to the 16th century, with Pascal's adding machine (1642), later Charles Babbage's difference engine (1822) and Vannevar Bush's differential analyzer (1931). It was not until WW2 that it was realized that the need for fast and accurate computations was paramount in the design of atomic weapons. The push for the first computer was on and the first fully electronic computer, the ENIAC was built 50 years ago.

The ENIAC was built at the University of Pennsylvania by physicist John Mauchly and electrical engineer J. Presper Eckert, on a project for the US Army Ordnance Corps. The design was based on the Mark I computer which had been built by IBM in 1944 and sent to Harvard University, and on the work of John Atanasoff, a physicist at Ohio State University, who had been working since the mid 1930's on the use of vacuum tube circuits for computing [1].

Storing a "program" in memory was not developed until 1950 with the advent of the Electronic Discrete Variable Automatic Computer (EDVAC), which was built for the Air Force. In 1952 John Von Neuman, who was on a project sponsored by the Office of Naval Research, the Air Force, and the Atomic Energy Commission, built the Institute for Advance Studies computer. Other machines that followed were the Electronic Delay Storage Automatic Computer (EDSAC), at Cambridge University in 1949, and the Whirlwind computer at MIT in 1951. The first US computer to use a magnetic drum memory was the Atlas built for the National Security Agency [2] and in 1951 Remington Rand built the UNIVAC-1 for the US Bureau of Census. IBM came out with the first stored-program computer in 1954 with the release of the IBM 701.

Just a few years before 1947 another parallel revolution was being orchestrated at Bell Labs. Just before Christmas of 1947, physicists William Shockley, John Bardeen, and Walter H. Brattain, completed an experiment on the first solid state transistor. It was a crude germanium device using gold foil as contacts which was cemented to a polystyrene base to form the emitter, collector, and base. They observed, however, that when a V_{cb} voltage was applied to the device, a voltage gain of near 100 would be obtained, and that such gain would operate into the audio region. It was an accomplishment that would eventually bring them the Nobel Prize in Physics years later. The news was not conceived at the beginning to be of profound importance. Bell Labs did not release the announcement until 7 months later. *The New York Times* buried the story, almost on the last page, on July 1, 1948, under a column known as "The News of Radio", and it read as this: "...A device called a transistor, which has several applications in radio where a vacuum tube ordinarily is employed, was demonstrated for the first time yesterday at Bell Telephone Laboratories, 463 West Street, where it was invented. The device was demonstrated in a radio receiver which contained none of the conventional tubes. It also was shown on a telephone system and in a television unit controlled by a receiver on a lower floor. In each case the transistor was employed as an amplifier, although it is claimed that it can also be used as an oscillator, in that it will create and send radio waves. In the shape of a small cylinder, about a half-inch long, the transistor contains no vacuum, grid, plate or glass envelope to keep the air away. Its action is instantaneous, there being no warm-up delay, since no heat is developed as in a vacuum tube.

The working parts of the device consists solely of two fine wires that run down to a pin-head of solid semiconductor material soldered to a metal base. The substance on the metal base amplifies the current carried to one wire and the other wire carries away the amplified current.”

In 1956 IBM released the IBM 704 computer, which had a ferrite core memory. Its memory could store 32 768-bit words and the computer cost about \$1 million. Magnetic drums served as a secondary storage system. Computers until then had no operating systems but a symbolic assembler program was available to program the machine. It was concluded that a powerful language needed to be developed and a “formula translator” (FORTRAN) language was soon introduced by John W. Bachus with other researchers. Based on the work and great advances in the transistor, the first solid state computer, the IBM 7090, was released in 1960. Magnetic core, however, remained the main technology for random access memory (RAM).

In 1957, William Norris and Seymour Cray started a new company known as Control Data Corp. (CDC). The company began to manufacture lower-end computers, starting with the CDC 6600 in 1964. Digital Equipment Corp. (DEC) which was founded by Ken Olsen, produced the first programmed data minicomputer, the PDP1 (1960), with a memory capacity of 16 384 18-bit words. In 1959, Jack Kilby, a Texas Instrument engineer, constructed the first complete circuit on a single substrate. Texas Instruments would later pioneer the same approach using silicon. A physicist at Fairchild (this company was founded by William Shockley disciples from Bell Labs), later introduced the idea of producing circuits using photolithography with the silicon planar technology. This method became the standard approach followed by manufacturers of integrated circuits all over the world and spawned the tremendous growth of the microelectronics industry.

In 1966 IBM brought into the market what was to become IBM’s most famous model, the IBM 360. The model brought IBM into the undisputed position of the leading supplier of mainframe computers for both the business and scientific communities. These computers found their way into most universities, government labs, and Fortune 500 companies. At the same time, in the low-end market, DEC controlled with the PDP line. Its most famous model was the PDP-11, with its sophisticated operating system and very flexible input/output structure.

Among the other milestones was the replacement in 1969 of the CDC 6600 by the CDC 7600 as the first super-computer. In terms of super-computers, the first so called parallel processor was developed in 1971 by Burroughs Corp. the Illiac IV, which was the first computer to use semiconductor memory. At the end of 1970, the first microcomputer (4 bits), the Intel 4004 was conceived, but it was not until 1975 that the first personal computer, Altair 8800, was developed, using the Intel 8080 microprocessor.

Starting from 1976, the increase of computer power and hardware increased by leaps and bounds. (It was also about this time that the first hand-held high performance calculators appeared and cost a lot of money). The Cray-1 supercomputer was introduced in 1976, which was the first commercially successful vector computer. Other vector computers followed such as the Cray X-MP and the Cyber 205 from CDC. These supercomputers introduced a “missing link” in the pursuit of scientific endeavors: computational science; the other two pillars were experimental work and theoretical work. In the low-end, Apple computer introduced the Apple II in 1978, and IBM followed in 1981 with the IBM PC with its DOS operating system developed and marketed to IBM by a then very small company known as Microsoft. More powerful scientific desktop computers were introduced in 1980 with the Apollo workstation. However, workstation computing did not really take off until two years later when Sun Microsystems introduced a scientific workstation which eventually dominated the market because of the use of an open operating system, UNIX.

It was in 1985 when parallel commercial machines became available. The first of such machines was the CM-1 (single instruction, multiple data stream) by Thinking Machines Corp. The second parallel computer was the iSPC, a multiple instruction, multiple data stream machine from Intel. The advantages of parallel computers lie in the lower cost to increase performance. The other approach in supercomputers using even faster processors, became too costly. The disadvantage of parallel computing lies in software; since it is very difficult for users to learn how to optimize the computing power and performance of such computers. They are not user-friendly and not general purpose.

We conclude this discussion with the extraordinary changes that also occurred in computer communications. In 1968 DOD's DARPA initiated a project to study ways to increase and facilitate communication among computers. That was the beginning of Arpanet in the 1980's Borrowing the idea of Arpanet, Bitnet was started in 1981 at the City University of New York. This network grew quickly to accommodate an increased number of users at scientific institutions. By the middle of 1985, similar computer networks were present in many places all over the world; thus begun the Internet. All of these networks eventually developed a language for sharing data known as the TCP/IP (Transmission control protocol/internet protocol) and sharing files known as the FTP (file transfer protocol). Toward the end of 1980's, the data sharing approach for the Internet was developed as the world wide web (WWW) in which information in a wide range of formats could be accessed in a universal hyperlinked arrangement. A user friendly tool for the WWW was developed in 1992 (Mosaic) but today there are others. We end with Figure 1, showing a performance vs, time-line of the computer age as computer technology progressed since the 1950's.

References:

- [1] A.W. Burks, A.R. Burks, "Ann. Hist. Of Computing", Vol. 3, 31-, 1981.
- [2] S.S. Snyder, "Ann. Hist. Of Computing", Vol. 2, 60, 1980.

Figure 1. Computer Technology Growth over the last 50 years. Some CEM Milestones.

MFlops

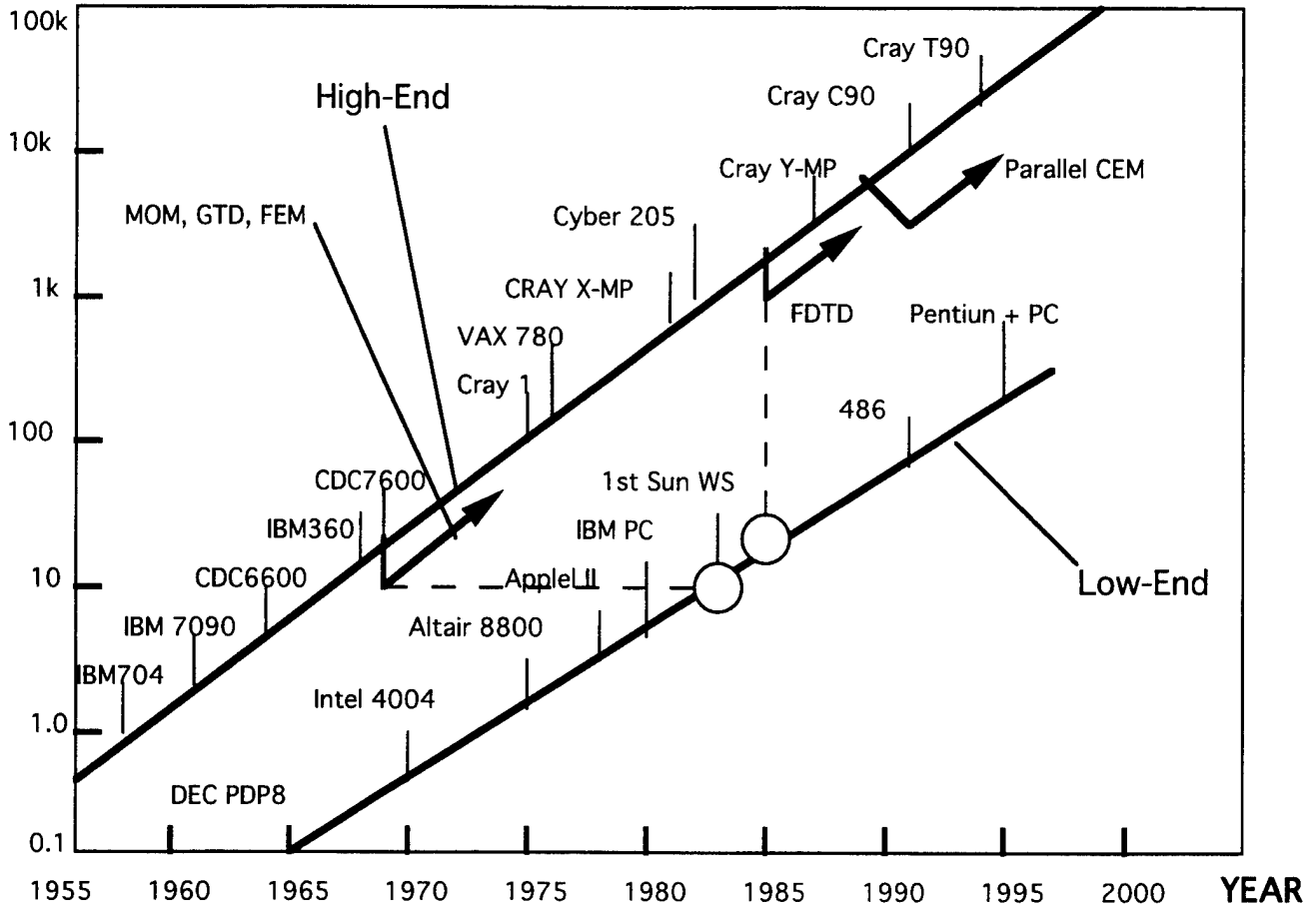

The Practical CEMist
- Practical Topics in Communications -

Perry Wheless, K4CWW

Time flies when you are having fun! It must be true - my fun-meter is pegged out, and time is flying. The first installment of **The Practical CEMist** appeared in the March 1994 *ACES Newsletter*. Since then, we have been fortunate enough to receive some interesting and useful articles for publication. It is gratifying to provide a forum for papers which merit attention and distribution, and which might not receive publicity otherwise. When it comes to practical applications and topics, the peer-review academic journals simply are not interested. On the other hand, the papers in this series have CEM content which is at a level of sophistication that precludes publication in most amateur radio or 'communicator' magazines. In short, **The Practical CEMist** has provided a distinctive service and outlet, unavailable elsewhere. On behalf of the *ACES Newsletter* staff and the ACES membership, I would like to extend our thanks to the authors who have maintained this series (continuously) with their manuscript submissions over the past three years.

For this issue, I am pleased to report that the featured article is "*The V-Yagi: A Lightweight Antenna for 40m*," co-authored by Nathan A. Miller (NW3Z) and James K. Breakall (WA3FET). Jim Breakall is one of the charter members of ACES, and requires no introduction. Jim has participated as an organizer and presenter in several NEC short courses, and especially enjoys NEC-based analysis and synthesis of HF wire antennas. Working diligently in his luxurious office facilities at Penn State University, he has produced many outstanding papers for the scientific literature, trade magazines, and amateur radio publications; now, please join me in making Jim welcome as a contributing author to **The Practical CEMist** series. Nathan Miller has been involved in antenna research with Jim Breakall at PSU in recent years, and we look forward to having Nathan as an active ACES member after completion of his graduate studies. Their paper describes an attractive lightweight antenna for the 40-meter ham band. In addition to reduced windload, this antenna offers direction switching and electrical performance optimized by application of the NEC•OPT4D code.

About twenty-five licensed amateurs participated in a first-time social dinner at ACES 96. At the time of this writing (January), plans for a similar gathering at ACES 97 are incomplete, but it does appear likely that we will try to establish a regular event for "Hamz in ACES." The most likely time for 1997 is Monday evening, March 17. You may expect posted notices about this event to be in the on-site conference registration area at the Naval Postgraduate School. Appropriate maps will be available from Pat Adler in the registration area. Also, please contact Perry Wheless via e-mail at wwheless@ualvm.ua.edu if you would like to assist with arrangements for such an event, or if you require additional advance information. CU in Monterey in March!

73 de K4CWW

The V-Yagi: A Light-Weight Antenna for 40 Meters

Nathan A. Miller, NW3Z
James K. Breakall, WA3FET
Department of Electrical Engineering
The Pennsylvania State University
Electrical Engineering East Building
University Park, PA 16802

1. Introduction

The base concept of the antenna is a standard three element Yagi-Uda type array. While in conventional Yagi construction all three elements are constructed of aluminum tubing, the V-Yagi uses parasitic elements constructed of wire to lower both the windload and the weight of the array. By using inductively loaded parasitic elements, the array is designed so that directivity can be instantly switched by 180 degrees.

1.1 Direction Switching

To accomplish direction switching, both parasitics are constructed to be directors with loading inductors across the split center of the element. Remotely operated vacuum relays are placed across the parasitic center so that when the relay is closed, the center of the element is shorted and the element appears to be a director. When the relay is opened, the inductance appears across the element center and the element performs as a reflector. By using a simple DC power supply and switch, the relays are closed one at a time to provide direction switching.

1.2 The Sloped Parasitics

To facilitate construction, the tips of the parasitic wires are sloped towards the driven element where cross-members are used to support the ends of the wires. The cross-members are electrically isolated from the array and do not contribute to its operation. Through modeling with the Numerical Electromagnetics Code (NEC) [1], it was determined that while the sloping of the parasitic elements does degrade performance, especially forward gain, to some extent, acceptable performance can still be obtained. An unscaled diagram of the antenna is shown below in Figure 1, where the boom is 40' tip-to-tip, the driven element is approximately 65' tip-to-tip and the cross-members are 20' total length.

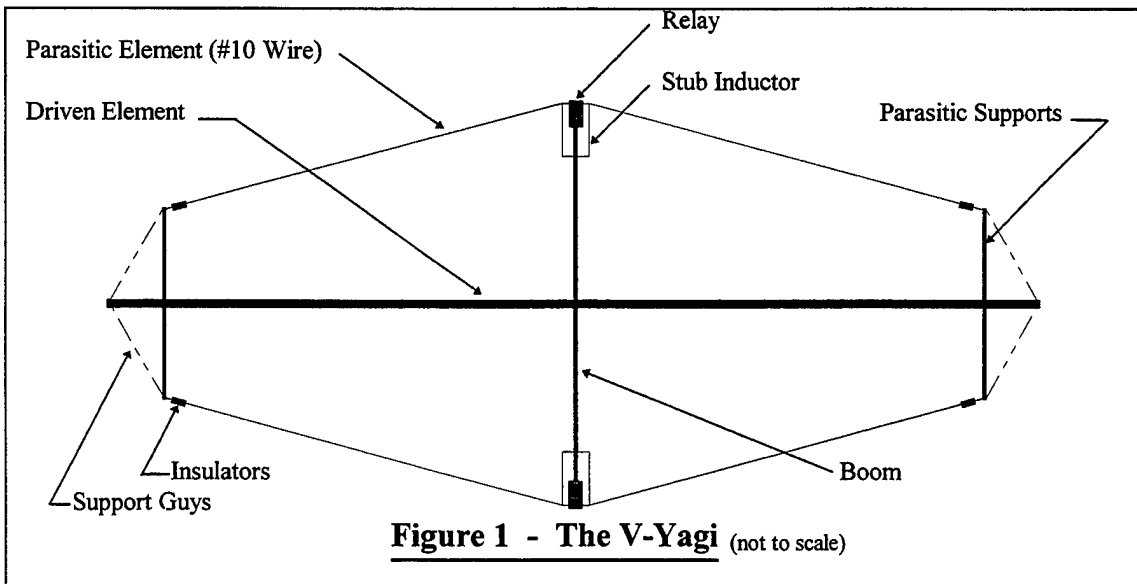

2. Electrical Design and Optimization of the Array

The antenna was designed and optimized using NEC•OPT4D [2], which is based upon NEC Version 4. In the initial design phases, only the three elements were included in the model, neglecting effects from the parasitic supports. After the antenna had been optimized, the parasitic supports were added to the design. It was found that if the supports were constructed of a single length of aluminum, the pattern and feed-point impedance of the antenna were adversely affected. After different models were tried, it was found that if each cross member was electrically broken into four separate lengths, there was very little effect.

2.1 Predicted Response

The final NEC model, predicts the following free space responses.

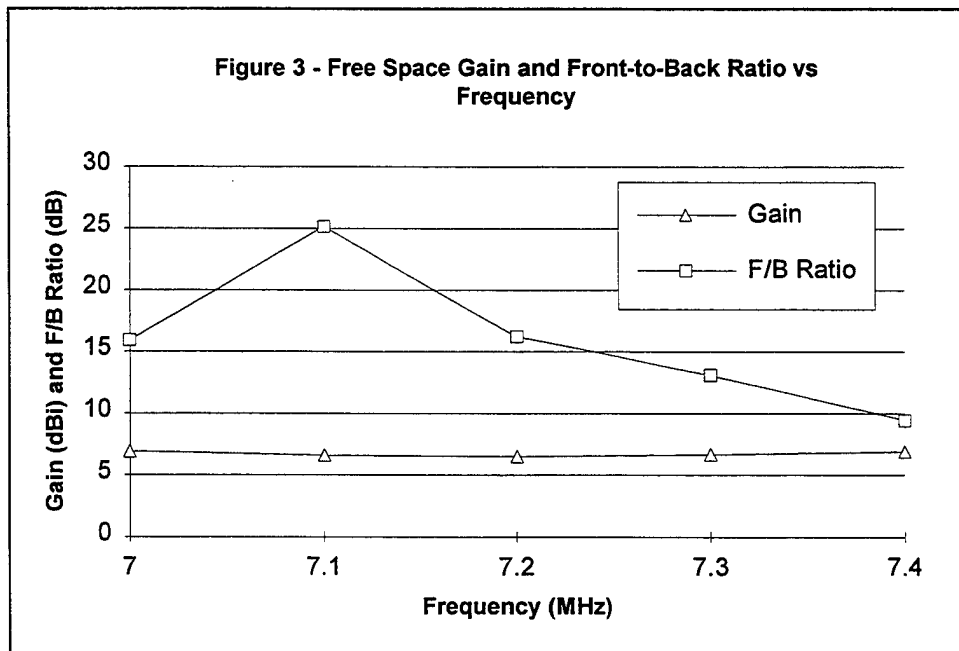
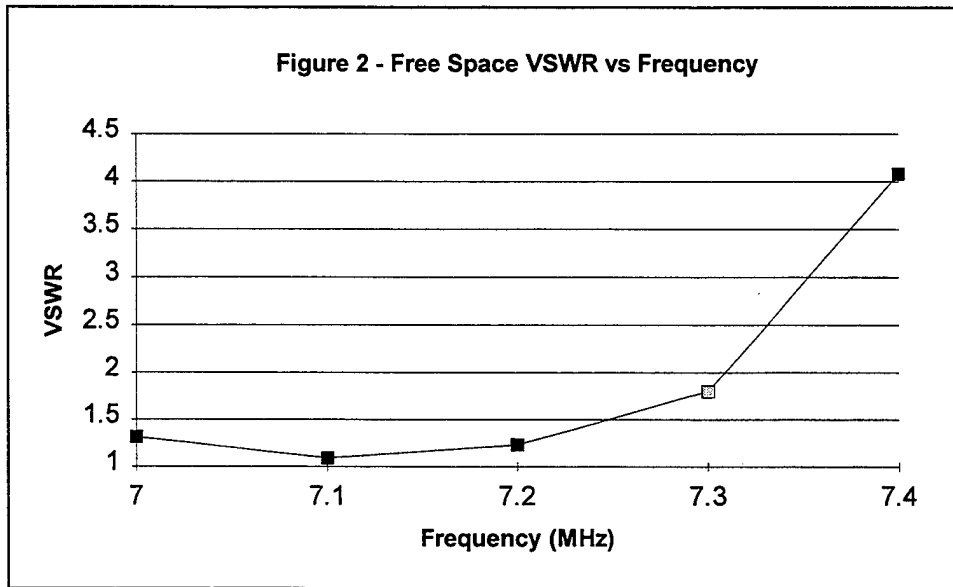

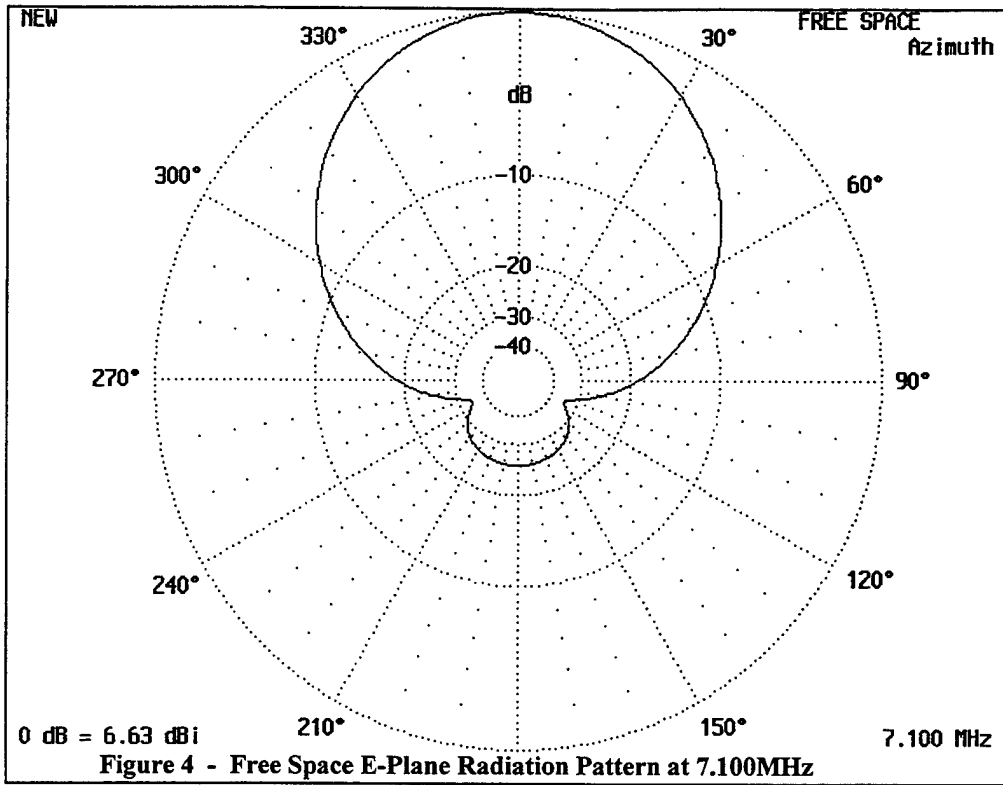

3. Mechanical Design and Construction

The driven element and boom were designed with the aid of YagiStress [3] software which is used to determine the weight and the un-guyed sag of the element. This software allows the user to input any tapered tubular element and gives the weight, windload, sag and wind survivability of the element. As the V-Yagi is a complex antenna, however, the wind survivability cannot be calculated with this program and is largely unknown.

There are two different types of tubing used in this antenna. The 2.500" and 2.250" diameter tubing is an extruded 6061-T6 alloy with .125" walls. All of the other tubing is a drawn 6063-T832 alloy with .058" walls. The parasitic elements and stub inductors are constructed of #10 Alumaweld™ aluminum plated steel wire.

3.1 The Driven Element

The half-element, after electrical optimization, is shown in Figure 5 with tubing diameters above the element and exposed length below. The joints are all overlapped by 4" to allow for connection with the exception of the junction of the 2.00" and 1.875" tubing. To add extra strength to the element, the 1.875" tubing extends inside the entire length of the 2" tubing, making the 2.00" section a double wall. The total weight of the driven element as calculated by Yagi-Stress is 47 lbs.

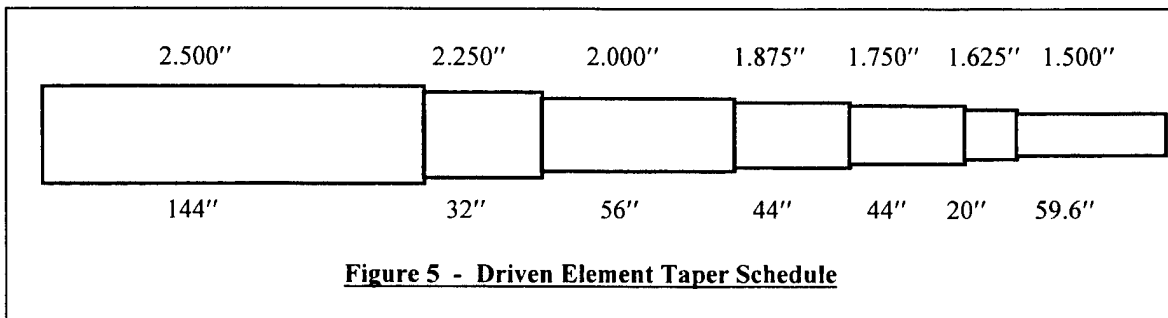

Each junction is coated with an anti-oxidant compound and is secured with four aluminum rivets set 90° apart [4]. Once each element half was assembled, they were connected together and to a mounting plate as discussed in the next section.

3.1.1 The Dipole Feed and Insulation of the Driven Element

The center of the driven element must be isolated from both the support mast and the boom, as well as be split for a dipole feed. Two pieces of fiberglass tubing were used to provide insulation and strength to the center of the element. A 1' long piece of fiberglass with an outer diameter of 2.250" was inserted inside the center of each element half while a 2' long piece of 3.00" fiberglass tubing was placed over the exterior of the junction. The two halves of the driven element are spaced 3" to prevent arcing during high power transmitting. A 5 kW 1:1 balun is attached to the feed point to match the unbalanced coaxial feed line to the balanced element.

3.2 Assembling the Parasitic Supports

The parasitic elements are each constructed in two halves, each 378.9" long, with insulators on each end. The cross-members which support the outer ends of the parasitic wires must be isolated from the driven element and broken into segments to decouple them from the array. The members are made from 1.25" tubing, and where the element is broken, a piece of 1.50" OD (1.25" ID) fiberglass tubing is used to join the segments. Initially, each aluminum section of the support was separated 1" by the fiberglass section, but during testing, the support was found to couple significantly to the driven element. To eliminate the end loading effects, the spacing between aluminum sections in the center of each support was increased to 12." The parasitic support attaches to the driven element on the 1.500" tip section which is covered with a 6" long section of 2.0" OD (1.5" ID) fiberglass tubing at the mounting point. A simple four U-bolt plate clamp similar to the driven element-to-mast plate is used to mount the support. With the fiberglass insulation in place, the parasitic support is isolated from the clamp which is also isolated from the driven element to reduce end loading effects.

3.3 Design and Construction of the Boom

One reason that the weight of the V-Yagi is so low is that the boom need only be strong enough to support the center of the wire parasitics and the stub inductors at each end. While a conventional Yagi boom must be constructed to support heavy tubing elements and is made of 3" or larger heavy wall tubing, this boom begins with 2.00" aluminum and tapers to 1.75" at the tips. The boom was simple to construct and weighs only 20.5 lbs. The boom is mounted on the mast directly above the driven element with its own mounting plate. The complete boom is shown below in Figure 6.

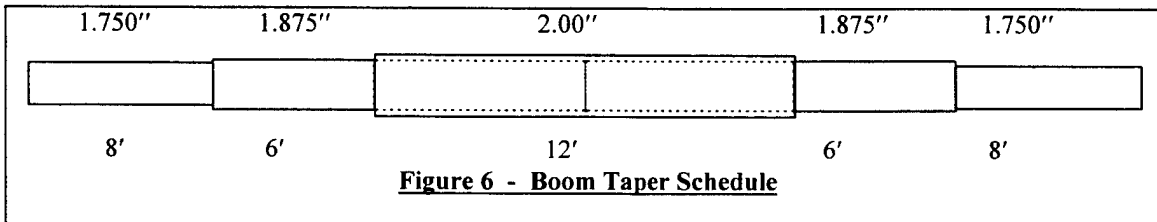

Figure 6 - Boom Taper Schedule

3.4 Construction of the Stubs and Relays

The optimization yields a stub inductance of 3.122 μ H. The stubs are constructed from a shorted parallel wire transmission line made of #10 AlumaWeld™ spaced 5" with fiberglass rod. The end of the stub is shorted with an aluminum plate clamp which can be moved along the stub for fine tuning. The vacuum relays are housed in small plastic boxes in the center of the stub with wire leads that connect to the stub at the same point at which the parasitic ends are connected.

3.5 Support Guys

The weight of the parasitic supports necessitated that the driven element be vertically guyed for support. Vertical support guys were added at the parasitic support attachment point on the driven element and are attached to turnbuckles on the mast four feet above the driven element. Vertical guys are also placed from the tips of the boom to the turnbuckle attachment point to give extra strength to the boom. Horizontal support guys, as shown in Figure 1, are used from the driven element tip to the ends of the parasitic supports to counter the tension in the parasitic wires. All guy wires are made of non-metallic Phyllystran™, a PVC coated kevlar rope, to ensure that there is no electrical interaction.

4. Testing the Antenna

The antenna was constructed and tested at the Electrical Engineering Department's Antenna Research facility at Rock Springs, PA. The antenna was mounted on a 50' tower with a rotator for azimuthal rotation and is fed with 100' of Belden 9913 50 Ω

low-loss coaxial cable. A second tower, 230 feet away, was fitted with a half-wave dipole at the same elevation for testing. The separation between the towers is approximately two wavelengths; far enough to assume far field performance for these rough measurements. The testing dipole was fed with a 10 W carrier at the test frequency with a Kenwood TS870 transceiver. The V-Yagi was connected to an ICOM 781 transceiver, used as a receiver, through a 81 dB step attenuator. The antenna was then rotated to point exactly at the test dipole and the relays were switched to be directional towards the test dipole. With the transmitter on, the attenuator was adjusted so that the received signal was an "S9" reading on the receiver signal strength meter. The antenna direction was then switched so that the directivity was 180 degrees from the test dipole and attenuation was removed until the signal strength was once again an "S9" reading. The amount of attenuation removed is equal to the Front-to-Back Ratio of the antenna at that particular frequency.

To check VSWR, the attenuator between the ICOM 781 and the V-Yagi was removed and the VSWR was checked with the 781's internal VSWR meter using a 100 W carrier output. Although the VSWR at the end of the coax is not exactly the same as at the feed point, it was assumed the two to be identical to allow for a fast measure of the antenna's performance.

4.1 Final Results

The F/B Ratio and VSWR of the antenna were measured across the frequency band. The graphical results are shown in Figures 7 and 8.

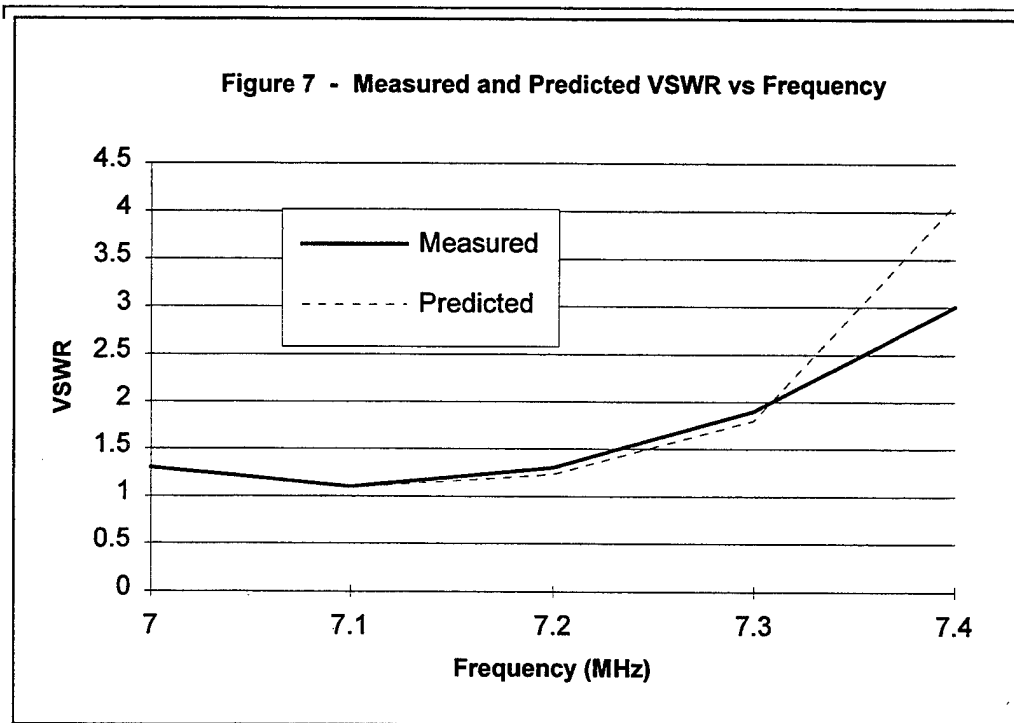

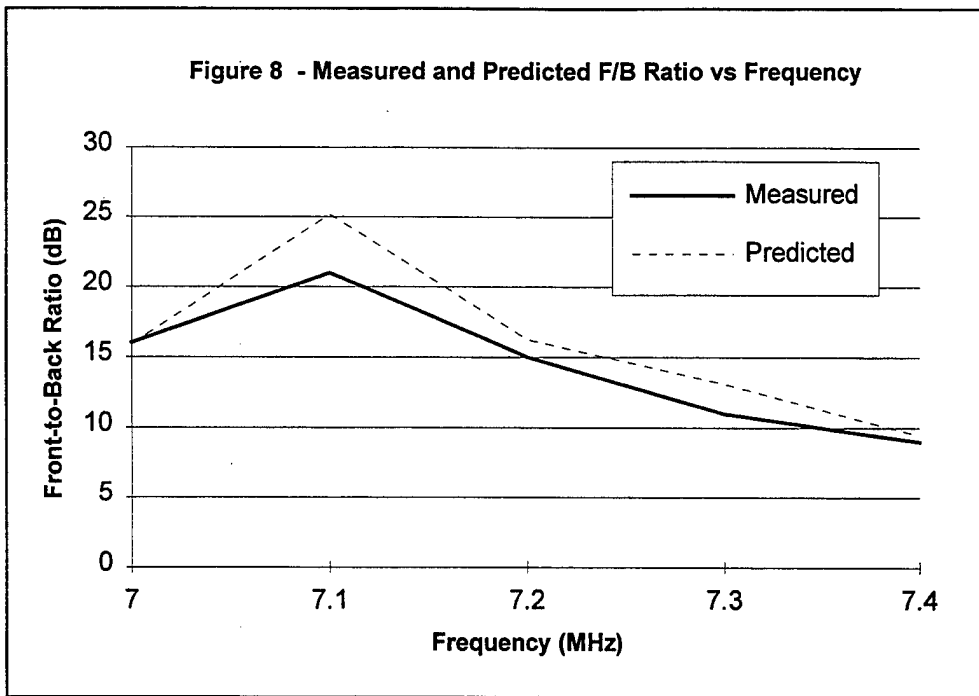

4.2 Discussion of Results

From Figure 7, it is seen that the measured VSWR falls very close to the expected values. Although the expected VSWR plot is at the antenna feedpoint, the value measured at the transmitter is close enough for a cursory comparison. In Figure 8, it is seen that while the F/B Ratio follows the same form, the measured peak is 4 dB down from the NEC model. Because the transmitting and receiving antennas are located so close together and only about .4 wavelengths above ground there are many inaccuracies with the measured F/B values. The uneven terrain, presence of other towers and buildings all contribute to scattering the signal near the antenna. Non-quantitative observations were made using European broadcast stations as a reference, and the antenna appeared to have a substantial F/B Ratio at these radiation take-off angles.

5. Recommendations

The parasitic capacitance present at the driven element center, parasitic wire connections and the parasitic support attachments on the driven element are not present in the model and may have some effect on the performance. A network analyzer or other impedance meter would be ideal to check the exact impedance of each element but was not done in this case. An alternate method would be to feed each of the elements individually, while the other elements are left open at the center, and find the VSWR nulls. By adjusting the exact resonance of each element, an accurate match to the NEC model could be virtually guaranteed.

The stub inductors should also be checked with an RF impedance meter to ensure that they are the proper value. If these inductors are not exact, there will be serious degradation of both forward gain and F/B Ratio.

5.1 Mechanical Design of the Antenna

In the design of the V-Yagi there was no mechanical strength evaluation performed. The antenna was built entirely "to feel" as far as what sizes of tubing to use and where the members should be supported. A detailed analysis of the stresses and failure points of the antenna is necessary to make any judgments on its wind and ice load survivability.

6. Summary

This antenna has excellent performance for its size and weight. The exceptional front-to-back ratio is greatly enhanced by the direction switching capability. The VSWR is extremely low across most of the band and is only a problem at the extreme top of the band. Due to the construction methods and ready availability of materials, the cost of the V-Yagi is well under that of commercial Yagi's.

While it is not as mechanically rugged as a conventionally constructed antenna, at approximately 85 lbs it is about 1/3 the weight of most conventional Yagi arrays. Its low weight and windload allow it to be used by amateur radio operators who cannot afford the larger and prohibitively expensive towers and rotators required for larger antennas.

References

- [1] "Numerical Electromagnetics Code" - NEC-4, Lawrence Livermore National Laboratory, 1992
- [2] "NEC•OPT Antenna Design and Optimization Software System", Paragon Technology, Inc., 1994
- [3] "YAGISTRESS Antenna Structural Modelling Software," Ver. 1.53, Kurt Andress, 1992
- [4] Leeson, David B., Physical Design of Yagi Antennas, The American Radio Relay League, 1992

Tutorial Article

Dr. Cynthia M. Furse of the University of Utah has contributed the tutorial "Applications of the Finite-Difference Time-Domain Method to Bioelectromagnetic Simulations" for this issue of the newsletter.

Cynthia M. Furse was born in Stillwater, Maine, May 7, 1963. She received her B.S.E.E. degree with a mathematics minor magna cum laude in 1986, M.S.E.E. Degree in 1988, and Ph.D. degree in 1994 from the University of Utah. She is currently an Assistant Professor at the University of Utah with a research emphasis on numerical bioelectromagnetics including high-resolution modeling of the human body for both low and high frequency applications, analysis of cellular telephone interactions with the body, and parallel computation for large scale applications. She has worked as a research scientist for Chevron Oil Field Research Company, and as an instructor and research associate at the University of Utah. She enjoys camping, hiking and skiing, playing classical violin and bluegrass fiddle, teaching science to young children, and is currently writing a book on the History of Emigration Canyon, where she lives in a wilderness setting with her husband and two children.

If you have ideas or suggestions for future tutorial articles, would like to contribute a tutorial article to the newsletter, or have comments on past articles, please feel free to contact me:

James L. Drewniak
Electromagnetic Compatibility Laboratory
Department of Electrical Engineering
University of Missouri-Rolla
Rolla, MO 65401
(573) 341-4969
emial: drewniak@umr.edu

I would greatly welcome suggestions and contributions.

Application of the Finite-Difference Time-Domain Method to Bioelectromagnetic Simulations

Cynthia M. Furse
Department of Electrical Engineering
University of Utah
Salt Lake City, Utah 84112

I. Introduction

The finite-difference time-domain (FDTD) method has been used extensively over the last decade for bioelectromagnetic dosimetry – numerical assessment of electromagnetic fields coupled to biological bodies [Gandhi; Lin & Gandhi]. Values of interest in these assessments include induced current or current density and specific absorption rate (SAR), which is a measure of absorbed power in the body. The FDTD algorithm is extremely simple and efficient, which has made it one of the most versatile numerical methods for bioelectromagnetic simulations. It is particularly well suited to these applications because it can efficiently model the heterogeneity of the human body with high resolution (often on the order of 1mm), can model anisotropy and frequency-dependent properties as needed, and can easily model a wide variety of sources coupled to the body. It has been used to analyze whole-body or partial-body exposures to spatially uniform (far field) or non-uniform (near-field) sources. These sources may be sinusoidally varying (continuous wave (CW)) or time-varying such as those from an electromagnetic pulse (EMP). The FDTD method has been used for applications over an extremely wide range of frequencies, from 60 Hz through 6 GHz, and also for broad-band applications. This paper describes several of these applications, and some of the details of how the FDTD method is applied to bioelectromagnetic simulations.

II. The Finite-Difference Time-Domain Method

The FDTD method was originally developed by [Yee] and has been described extensively in the literature [Kunz & Luebbers; Taflove]. This method is a direct solution of the differential form of Faraday's and Ampere's laws

$$\nabla \times E = -\mu \frac{\partial H}{\partial t} \quad (1)$$

$$\nabla \times H = \sigma E + \varepsilon \frac{\partial E}{\partial t} \quad (2)$$

Assuming that ε and μ are isotropic, frequency-independent, and constant over the region where the equation is being solved, (1) and (2) can be divided into six partial differential equations

$$\frac{\partial H_x}{\partial t} = \frac{-1}{\mu} \left(\frac{\partial E_z}{\partial y} - \frac{\partial E_y}{\partial z} \right) \quad (3a)$$

$$\frac{\partial H_y}{\partial t} = \frac{-1}{\mu} \left(\frac{\partial E_x}{\partial z} - \frac{\partial E_z}{\partial x} \right) \quad (3b)$$

$$\frac{\partial H_z}{\partial t} = \frac{-1}{\mu} \left(\frac{\partial E_y}{\partial x} - \frac{\partial E_x}{\partial y} \right) \quad (3c)$$

$$\frac{\partial E_x}{\partial t} = \frac{1}{\varepsilon} \left(\frac{\partial H_z}{\partial y} - \frac{\partial H_y}{\partial z} - \sigma E_x \right) \quad (4a)$$

$$\frac{\partial E_y}{\partial t} = \frac{1}{\varepsilon} \left(\frac{\partial H_x}{\partial z} - \frac{\partial H_z}{\partial x} - \sigma E_y \right) \quad (4b)$$

$$\frac{\partial E_z}{\partial t} = \frac{1}{\varepsilon} \left(\frac{\partial H_y}{\partial x} - \frac{\partial H_x}{\partial y} - \sigma E_z \right) \quad (4c)$$

The model space is then divided into a lattice of discrete unit cells, which is shown in Figure 1. A space point in the lattice is defined as $(x,y,z) = (i\Delta x, j\Delta y, k\Delta z)$, and any function of space and time is defined as $F^n(i,j,k) = F(i\Delta x, j\Delta y, k\Delta z, n\Delta t)$ where $\Delta x, \Delta y, \Delta z$ are the lattice space resolutions in the x,y,z coordinate directions, Δt is the time increment, and i,j,k and n are integers.

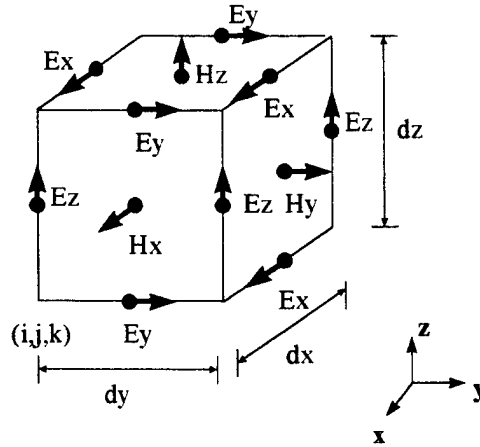

Figure 1: The "Yee" cell or FDTD lattice showing distribution of the electric and magnetic field components

The differential equations in (3) and (4) are then converted into difference equations using the central difference approximations

$$\frac{\partial F^n(i, j, k)}{\partial x} = \frac{F^n(i + \frac{1}{2}, j, k) - F^n(i - \frac{1}{2}, j, k)}{\Delta x} \quad (5a)$$

and

$$\frac{\partial F^n(i, j, k)}{\partial t} = \frac{F^{n+\frac{1}{2}}(i, j, k) - F^{n-\frac{1}{2}}(i, j, k)}{\Delta t} \quad (5b)$$

For evenly spaced lattices, the error for these equations is $(\Delta x)^2$ and $(\Delta t)^2$, respectively. Thus, these first order difference equations provide second order accuracy. Since the field components are interleaved on each unit cell as shown in Figure 1, the E and H components are half a cell apart, which is referred to as a “leap-frog” scheme. In addition to being leap-frogged in space, they are also leap-frogged in time. The E field is assumed to be at time $n\Delta t$, and the H field is assumed to be at time $(n+1/2)\Delta t$.

Applying the central difference approximations in (5a) and (5b) to (3a) and (4a) gives the difference equations

$$H_x^{n+1/2}(i, j, k) = H_x^{n-1/2}(i, j, k) + Chy(i, j, k)[E_x^n(i, j, k) - E_x^n(i, j + 1, k)] + Chz(i, j, k)[E_y^n(i, j, k + 1) - E_y^n(i, j, k)] \quad (6)$$

and

$$E_x^{n+1}(i, j, k) = (CE)E_x^n(i, j, k) + Cey(i, j, k)[H_x^{n+1/2}(i, j, k) - H_x^{n+1/2}(i, j - 1, k)] + Cez(i, j, k)[H_y^{n+1/2}(i, j, k) - H_y^{n+1/2}(i, j, k - 1)] \quad (7)$$

In these equations, E and H are generally of different orders of magnitude. To reduce the numerical errors which arise from taking the divided differences of significantly different values, a normalization factor,

$$H(\text{programmed}) = \sqrt{\mu_o / \epsilon_o} H(\text{physical}) \quad (8)$$

is used to make E and H be of the same order of magnitude. Using the value $\Delta t = \Delta x / (2c_o)$, the constants in equations (6) and (7) become

$$\begin{aligned} Chy &= c_o \Delta t / (u_r(i,j,k)\Delta y) \\ Chz &= c_o \Delta t / (u_r(i,j,k)\Delta z) \\ CE &= \frac{2\epsilon_o \epsilon_r(i, j, k) - \Delta t \sigma(i, j, k)}{2\epsilon_o \epsilon_r(i, j, k) + \Delta t \sigma(i, j, k)} \\ Cey &= \frac{2\Delta t \sqrt{\epsilon_o / \mu_o}}{\Delta y (2\epsilon_o \epsilon_r(i, j, k) + \Delta t \sigma(i, j, k))} \\ Cez &= \frac{2\Delta t \sqrt{\epsilon_o / \mu_o}}{\Delta z (2\epsilon_o \epsilon_r(i, j, k) + \Delta t \sigma(i, j, k))} \end{aligned} \quad (9)$$

Similar equations and constants are obtained for (3b),(3c),(4b),(4c). These constants can be used to represent anisotropic properties which are present in muscle and cardiac tissues at low frequencies by allowing the values of $\epsilon_r, \sigma, \mu_r$ to be different in the x,y,z directions. For biological tissues, $\mu_r = 1$.

The steps in the FDTD solution are:

- 1) Define model values of $\epsilon_r, \sigma, \mu_r$ at each location i,j,k, and calculate the constants given in (9).
- 2) Assume initial conditions (usually that all fields and the source are zero).

- 3) For each time step, n
 - a) Specify fields at source.
 - b) Calculate E^n for all locations.
 - c) Calculate $H^{n+1/2}$ for all locations.
- 4) Stop when the solution has converged. For transient fields, this means all of the fields have died away to zero. For sinusoidal fields, this means that all of the fields have converged to a steady-state sinusoidal value.

There are two constraints controlling what values are defined for the space resolutions, Δx , Δy , Δz , and the time resolution, Δt . The space resolution in bioelectromagnetic simulations is generally controlled by the grid resolution of the human model. Since these models are extremely difficult to create, only a few models are available in the world, and while grids can be adjusted somewhat (cells combined to reduce resolution, or subdivided to increase the resolution), for the most part only an isolated set of resolutions are available. Resampling of the model is possible, but in general, the grid resolution is more or less set. What is important is to determine the maximum frequency which a given resolution can be accurately used for. A rule of thumb is that the largest grid dimension, Δx , for instance, should not be larger than $\lambda/10$, where λ is the smallest wavelength in the model. This limitation comes from the fact that the numerical grid produces a certain amount of artificial (numerical) dispersion which increases with the grid size and direction of propagation as shown in Figure 2. When the resolution is $\lambda/10$, the numerical dispersion is approximately 1%.

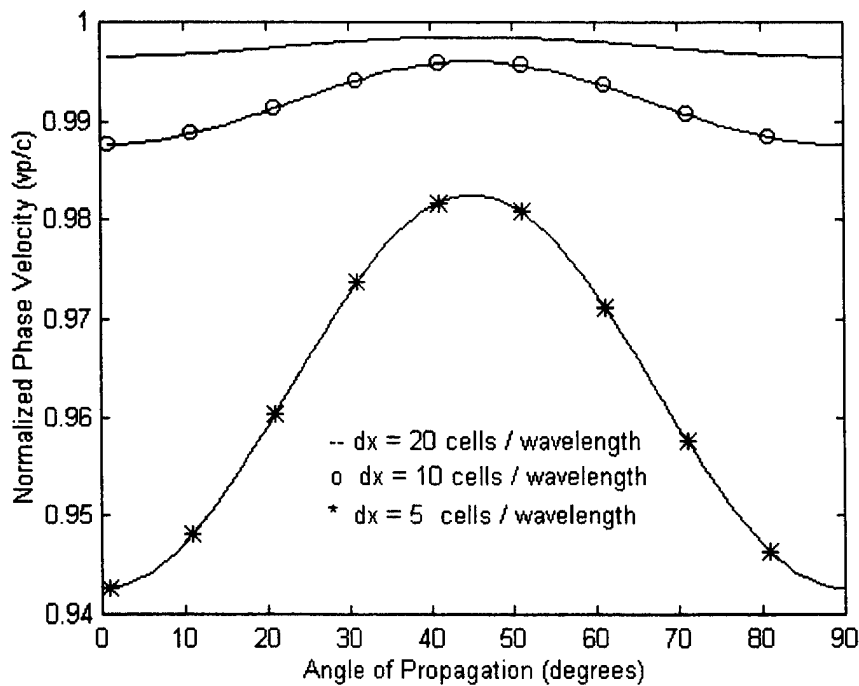

Figure 2: Variation of the numerical phase velocity with wave propagation angle in two-dimensional FDTD grid for three dimensions [Taflove]

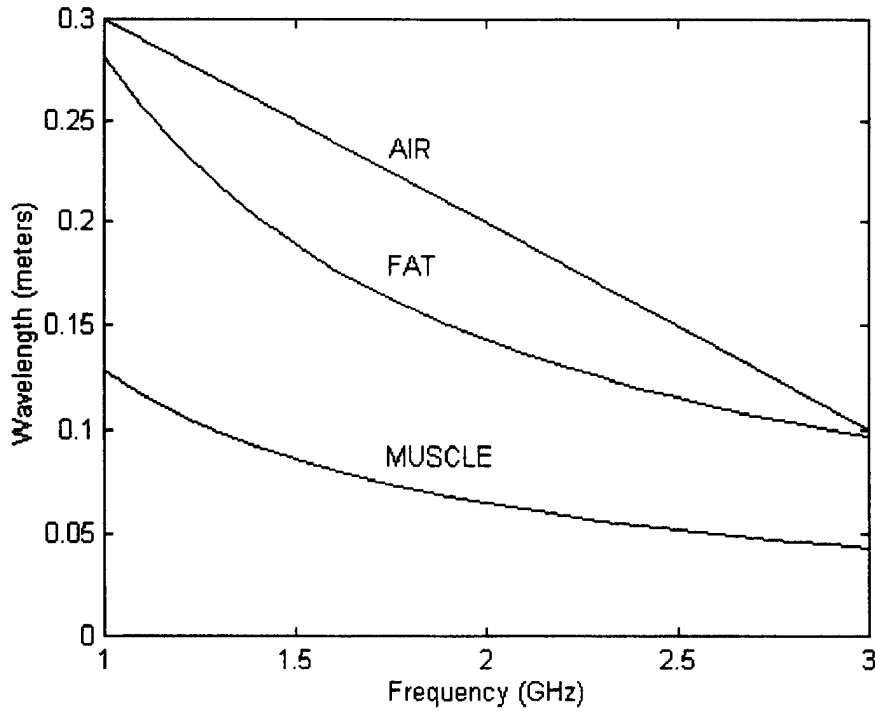

Figure 3: Wavelength of muscle, fat, and air as a function of frequency. Additional body tissues fall between fat and muscle.

In order to determine the maximum frequency a given grid size is suitable for, Figure 3 shows the wavelength as a function of frequency for several tissues of the body. Not only does the standard relationship between electrical properties and frequency control the wavelength, but the electrical properties of the tissues also vary with frequency. Although it is ideal to limit the use of a given grid to frequencies which make the resolution be less than $\lambda/10$, bioelectromagnetic simulations sometimes push this limit, and resolutions of $\lambda/4$ have been successfully used [Furse, et al., 1994]. For many simulations, this does not cause problems, because the wave is absorbed before it can propagate far, so the dispersion error is relatively small.

A second constraint is that to maintain the stability of the FDTD simulation the time resolution must be sufficiently small such that

$$\Delta t \leq \frac{1}{v_{\max} \sqrt{\frac{1}{\Delta x^2} + \frac{1}{\Delta y^2} + \frac{1}{\Delta z^2}}} \quad (10)$$

where v_{\max} is the maximum velocity of propagation in any material in the model. The value of $\Delta t = \Delta x/(2c_0)$, which is used in many FDTD codes, is well within this limit. These two constraints provide limits on the time and space resolutions which must be used in order to accurately model time domain behavior of a given waveform.

But what happens when a waveform is used which has frequency components above the “limit” of the FDTD grid, such as in many pulsed simulations? In this case, the

numerical dispersion in FDTD solutions serves an interesting purpose. It disperses these high frequency components, thus making it impossible for them to propagate and cause frequency aliasing errors [Furse, 1994]. This makes it possible to use any waveform, even a narrow rectangular pulse with near-infinite frequency spectrum as a source for FDTD simulations. The high frequency components do not propagate, so are effectively filtered out of both the time and frequency domain simulations. They provide no information, but also do not cause any errors.

III. The Frequency-Dependent FDTD Method

The electrical properties of biological tissues vary significantly with frequency, as shown in Figure 4. For single-frequency simulations, the FDTD method can be used, with the particular tissue properties at that frequency, but for broad-band simulations, this is not sufficient. The frequency-dependent finite-difference time-domain (FD)²TD method is therefore used to overcome this limitation. Two general approaches to the (FD)²TD method have been developed. One approach is to convert the complex permittivity from the frequency domain to the time domain and convolve this with the time-domain electric fields to obtain time-domain fields for dispersive materials. This discrete time-domain convolution may be updated recursively for some rational forms of complex permittivity, which removes the need to store the time history of the fields and makes the method feasible. This method has been applied to materials described by first-order Debye relaxation equation [Luebbers, et al. 1990; Bui et al.; Sullivan 1992], a second-order Lorentz equation with multiple poles [Luebbers, et al., 1992], and to a gaseous plasma [Luebbers, et al., 1991].

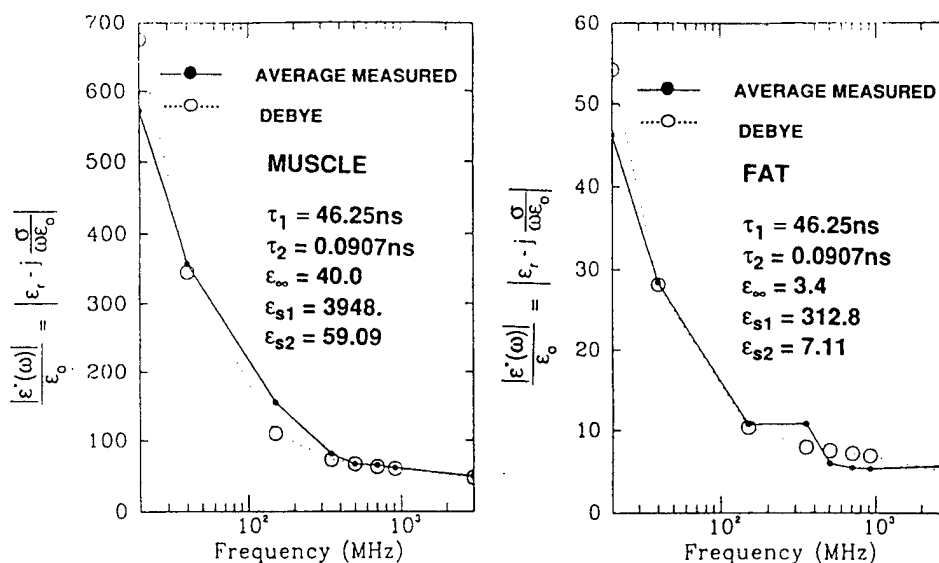

Figure 4: Electrical properties of fat and muscle as a function of frequency. Measured values from the literature are compared to those modeled with a second-order Debye equation [Furse, et al., 1994]

A second approach is to add a differential equation relating the electric flux density \mathbf{D} to the electric field \mathbf{E} and to solve this new equation simultaneously with the standard FDTD equations. This method has been applied to one-dimensional and two-dimensional examples with materials described by a first-order Debye equation or second-order single-pole Lorentz equations [Joseph, et al.; Lee, et al.], to 3D sphere and homogeneous two-thirds muscle equivalent man model with properties described by a second-order Debye equation [Gandhi, et al., 1993a, 1993b; Furse, et al., 1994], and to a heterogeneous model of the human body exposed to ultra-wide band electromagnetic pulses [Gandhi and Furse, 1993], as described below.

The time-dependent Maxwell's equations have already been given in (1) and (2). Ampere's law can be rewritten as

$$\nabla \times H = \frac{\partial D}{dt} \quad (11)$$

where the flux density vector \mathbf{D} is related to the electric field \mathbf{E} through the complex permittivity $\epsilon^*(\omega)$ of the local tissue by the following equation:

$$\mathbf{D} = \epsilon^*(\omega) \mathbf{E} \quad (12)$$

Since (1) and (11) are to be solved iteratively in the time domain, (12) must also be expressed in the time domain. This may be done by choosing a rational function for $\epsilon^*(\omega)$ such as the Debye equation with two relaxation constants:

$$\epsilon^*(\omega) = \epsilon_o \left[\epsilon_\infty + \frac{\epsilon_{s1} - \epsilon_\infty}{1 + j\omega\tau_1} + \frac{\epsilon_{s2} - \epsilon_\infty}{1 + j\omega\tau_2} \right] \quad (13)$$

Rearranging (13) and substituting in (12) gives

$$D(\omega) = \epsilon^*(\omega)E(\omega) = \epsilon_o \frac{\epsilon_s + j\omega(\epsilon_{s1}\tau_2 + \epsilon_{s2}\tau_1) - \omega^2\tau_1\tau_2\epsilon_\infty}{1 + j\omega(\tau_1 + \tau_2) - \omega^2\tau_1\tau_2} E(\omega) \quad (14)$$

where the dc (zero frequency) dielectric constant is given by $\epsilon_s = \epsilon_{s1} + \epsilon_{s2} - \epsilon_\infty$.

Assuming $e^{j\omega t}$ time dependence, (14) can be written as a time-domain differential equation

$$\tau_1\tau_2 \frac{\partial^2 D}{\partial t^2} + (\tau_1 + \tau_2) \frac{\partial D}{\partial t} + D = \epsilon_o \left[\epsilon_s E + (\epsilon_{s1}\tau_2 + \epsilon_{s2}\tau_1) \frac{\partial E}{\partial t} + \epsilon_\infty \tau_1\tau_2 \frac{\partial^2 E}{\partial t^2} \right] \quad (15)$$

As in [Gandhi, et al., 1993a, 1993b], this equation is then converted into a second order difference equation, which requires storage of one past time step for the \mathbf{D} and \mathbf{E} fields. Equations (1) and (11) are then solved subject to (15). The steps for the (FD)²TD method are:

- 1) Define value of $\epsilon^*(\omega)$ for each tissue and use least-squares to find an optimal fit of ϵ_{s1} , ϵ_{s2} , ϵ_{∞} , τ_1 , τ_2 in (13) for each tissue. Calculate constants for (15).
- 2) Assume initial conditions (usually that all fields and the source are zero).
- 3) For each time step, n
 - a) Specify fields at source.
 - b) Calculate \mathbf{E}^n for all locations.
 - c) Calculate \mathbf{D}^n for all locations.
 - d) Calculate $\mathbf{H}^{n+1/2}$ for all locations.
- 4) Stop when the solution has converged. For transient fields, this means all of the fields have died away to zero. Continuous wave fields are not used in $(\text{FD})^2\text{TD}$ simulations (since they are not broad-band, FDTD is used).

IV. Methods of converting from Time to Frequency Domain

Since the FDTD and $(\text{FD})^2\text{TD}$ methods are intrinsically time-domain methods, when frequency-domain information is required, some method of conversion must be used. Examples of frequency-domain parameters which are calculated are magnitudes of fields (for one or more frequencies), specific absorption rate (SAR), which is calculated from field magnitudes, currents or current densities, and integrated properties such as radiation pattern or total power absorbed or reflected. There are several methods which have historically been used to transfer from sampled time domain to frequency domain data for bioelectromagnetic applications. These are peak detection methods, Fourier transform methods, and a direct calculation method. The goal of all of these methods is to detect the magnitudes and possibly the phases of the time-domain fields. Which of the methods is used is particularly important in bioelectromagnetic simulations, since it is common for a huge number of time-to-frequency domain conversions to be required (such as at every location in the body for calculation of SAR or current density distributions), and the computer time and memory can be nearly as large as those required for the time-domain simulation itself.

The peak detection method is of historical interest only, as it is the least efficient and least accurate of the methods. The values of successive time steps in a sinusoidal simulation are compared to determine when the peak of the wave has been reached, and this value is recorded as the magnitude of the wave. This method is time-consuming (a series of IF-THEN computer statements), and requires storage of past-time values for comparison. It is the least accurate of the methods, as the peak may occur between successive time samples, so the value recorded for magnitude will be slightly lower than the actual magnitude. Phase calculations using this method are highly inaccurate for this reason.

The Fourier transform method is probably the most widely used of the methods of determining magnitude and phase, and is highly accurate. For either transient or sinusoidal calculations, the complex magnitude of the wave can be calculated from the time-domain waveform using

$$G(k\Delta f) = \Delta t \sum_{n=0}^N g(n\Delta t) e^{-j 2\pi k n \Delta t} \quad (16)$$

where

$G(k\Delta f)$ is the complex magnitude

$g(n\Delta t)$ is the time-domain waveform

Δf is the frequency resolution

Δt is the time resolution

n is the time step index = 0, 1, 2, ... N

k is the frequency index

N is the length of the Fourier transform = $1/(\Delta f \Delta t)$

For transient simulations, the simulation may converge, and all field values, $g(n\Delta t)$ may go to zero before the summation in (16) is complete. In that case, the summation can be stopped before N summations, which saves computational time. For sinusoidal (single-frequency) applications, the summation is done for one cycle after the simulation has converged to steady-state. This requires running the FDTD simulation an additional cycle, which can be burdensome or even impossible at lower frequencies.

The Fourier transform in (16) can be calculated with either the Fast Fourier Transform (FFT) or the discrete Fourier transform (DFT) in (16). It has been shown [Furse and Gandhi, 1995] that the DFT is actually faster than the FFT for FDTD applications, although many people still use the FFT method because of the convenience of prepackaged Fourier transform software. Both methods are equally accurate.

Time decimation [Bi, et al.] can be used to significantly reduce the length of the sum in (16), and improve the computational efficiency of the algorithm. This method recognizes that, although the FDTD constraints that $\Delta x \leq \lambda/10$ and $\Delta t = \Delta x/(2c_0)$ produce a sampled time sequence from the simulation which is far over-sampled in terms of the Nyquist criterion, that only two samples per cycle are actually required for accurate calculation of the magnitude and phase of the wave. Thus, the number of samples used in the Fourier transform can be significantly reduced. This applies to both transient and steady-state simulations.

Taking this one step further, a direct method [Furse] for finding magnitude and phase provides great flexibility of magnitude and phase calculations coupled with efficiency and accuracy. It is apparent that for sinusoidal simulations the two samples which are used need not be evenly spaced. This method is based on writing two equations in two unknowns (magnitude and phase) for the time-domain fields, and then solving the directly for the magnitude and phase. At a given location in space, we can write

$$\begin{aligned} A \sin(\omega t_1 + \phi) &= g_1 \\ A \sin(\omega t_2 + \phi) &= g_2 \end{aligned} \quad (17)$$

where A is the magnitude, ϕ is the phase, and ω ($=2\pi F$) is the angular frequency. At two times, t_1 and t_2 , the two values of g_1 and g_2 are known from the FDTD simulation. Therefore, these two equations can be solved directly for the unknowns A and ϕ . No theoretical constraints are given on t_1 and t_2 , so they can be taken to be the last two time steps of the simulation. This allows calculation of magnitude and phase with no additional computer memory, which is a considerable advantage in the large-scale simulations typical of bioelectromagnetic simulations. This method is also considerably more efficient than the Fourier transform methods, as it does not require a summation to be done over several (or several hundred) time steps. The DFT and peak detection methods require approximately as much computational time and memory as the FDTD simulation, if time-to-frequency domain conversions are required in all cells in the body, which is typical of bioelectromagnetic simulations. The direct method, on the other hand, requires virtually no computational time, and can be programmed with virtually no memory requirement. These significant advantages make it the primary method of choice for bioelectromagnetic simulations.

The direct solution method does have some limitations. First, it can only be used for single-frequency FDTD simulations. Second, it is only accurate when the simulation produces a clean, perfectly converged sine wave without DC offsets or noise.

The significant advantages of this method have led to its use in some novel applications. The first is the use of the direct method for determining convergence of sinusoidal simulations. It is relatively easy to tell when transient simulations have converged ... all the fields have gone to "zero". For sinusoidal simulations, this has been more difficult. Calculating the magnitude and phase historically required a full cycle of the simulation to be run "past convergence", and running still more cycles to check on convergence is often prohibitively expensive. Generally a few indicative test cases would be checked for convergence, and then similar simulations would be assumed to be converged in a similar amount of time. This direct method provides a way to calculate magnitude and phase with great efficiency, and without requiring a large number of time steps of the simulation to be run, so the calculations of magnitude and phase can be repeated within the simulation itself to test for convergence.

A second advance which this direct solution method has enabled is calculation of extremely low frequencies using the FDTD method. There has been no intrinsic limitation of the FDTD method for running low frequency simulations, but there was no method of extracting the magnitude and phase from these simulations. For a 6mm human model at 60 Hz, for instance, one cycle requires 1.6×10^9 time steps. It is not feasible to run even an appreciable portion of a cycle, which would be required by the Fourier transform or peak detection methods. Using this direct method, the solution can be found with about 2000 time steps. This application presents some unique numerical challenges, as the fields change so little from one time step to another. Unlike higher-frequency simulations where round-off errors between two immediate time steps are negligible, significant numerical error is observed when calculating the magnitude and phase if the last two time steps are used for extremely low frequencies. For the simulation described in section VIII.A, t_1

was taken to be 100 time steps before the final time step, t_2 , which reduced the numerical errors in this calculation.

V. Human Models and Tissue Properties

Model development is one of the significant challenges of numerical bioelectromagnetics. Models have progressed from the prolate spheroidal models of the human used during the 1970s to roughly 1cm models based on anatomical cross sections used during the 1980s [Gandhi, et al. 1992a] to a new class of millimeter-resolution MRI-based models of the body which are the hallmarks of research in the 1990s [Gandhi and Furse, 1995; Dimbylow, 1995; Olley & Excell, 1995; Stuchly, et al., 1995]. MRI scans provide an ideal initial data base for voxel-based models of this type, but the scans alone do not define the types of tissue which are in each location. Instead, MRI scans provide a voxel map of MRI densities, which unfortunately do not have a one-to-one correspondence to tissue type. These images are interpreted as grey-scale images by which the several tissues can be “seen”. Image segmentation is necessary to convert these density mappings into mappings of tissue type. This is generally done semi-manually, although automatic methods are under development.

Several MRI-based models of the human body [Gandhi and Furse, 1995; Dimbylow, 1995] or the head alone [Olley & Excell, 1995; Stuchly, et al., 1995; Jensen & Rahmat-Samii] are now in existence. With the exception of some basic automatic tissue classification based on MRI densities (dry tissue can be separated from wet tissue, for instance), these models have required significant effort to obtain, and there are many unique challenges in developing models suitable for use in bioelectromagnetic modeling.

First, there are issues which must be addressed in obtaining the MRI scans. It is important to use MR settings to optimize the contrast between the soft tissues, and to use saturation pulses to reduce pulsatile blood flow artifacts, and time gating to reduce blurring from breathing and the beating heart. Depending on the amount of time gating and optimization, scanning the complete body with a vertical resolution of 3mm takes 6 to 24 hours. The person being scanned will need to be repositioned during this time, as that is too long to expect a live person to hold still, and this presents some difficulties in rematching the images from successive positions. It is useful to position the person in exactly the stature that is desired for modeling, such as ensuring that the feet are in a “standing” position, as opposed to “relaxed”, and that the head is in alignment with the spine, as opposed to on a pillow. Arms have caused significant difficulty in several modeling efforts, as in a relaxed position, they tend to fall out of the range of MRI scanning. Most of these problems are eliminated if a cadaver is used as the subject to be scanned, such as in the Visible Man project [National Library of Medicine], although the difficulty of positioning the model is still a problem, and this model [National Library of Medicine] is also missing portions of the arms due to limitations of scanning range. Using a cadaver provides challenges in itself, as body fluids tend to pool at the back of the body, organs shrink or swell, and airways collapse very soon after death. It has also been

observed that the overall height of the body increases by several cm when it is lying (such as in an MR machine) as opposed to standing, for both live humans and cadavers.

An additional problem with MR scanned images is there is a tradeoff between signal-to-noise ratio and a shift which is seen between fat and water-based tissues such as muscle. When the signal-to-noise ratio is optimized, the fat will appear slightly shifted in location relative to muscle. The shift may be as much as 4-5 mm [Gandhi & Furse, 1995]. In general this is a minor issue, as the majority of fat deposits are sufficiently large that this shift is inconsequential. While the fat shift may not cause much difficulty in defining the regions of fat, it does cause difficulty in defining the regions of skin. On the "read" side of the model, the fat obliterates the skin layer, making it appear very thin, while on the other side of the model, the skin appears very thick. A solution to this problem is to specify a pre-defined thickness of skin covering the whole body, and to apply this with a computer algorithm after image segmentation of the other tissues. This algorithm can be progressively refined as needed, to control the thickness of skin throughout different regions of the body.

An additional consideration when developing a model for bioelectromagnetic simulations is the question of uniqueness of individuals. It has been shown that the height of a person affects how much current will be induced by high voltage lines [Deno], and that the size of the head (children as compared to adults) affects the 1-gram averaged SAR from cellular telephones [Gandhi, et al., 1996]. It has also been shown that minimal differences in 1-gram averaged SARs from cellular telephones were obtained for several head models without the ear [Hombach, et al.], although it is likely that differences in ear shape could affect the 1-gram averaged SAR. The "average" man is defined in [Snyder, et al.]. Although it is unlikely that any given model which is scanned will provide exactly the same height, weight, and organ sizes of the reference man, this source is useful to compare given organ weights of a tissue segmented model to be certain they are similar to expected values. Another option is scaling the voxel size of the image-segmented model to obtain a model with exactly the height (176 cm) and weight (71 kg) of the reference man [Snyder, et al.].

As an example of one tissue segmented model, the MRI-based man model developed at the University of Utah was taken with an MRI voxel size of 1.875 x 1.875 x 3mm. The software ANALYZE, developed at the Mayo Clinic was used to segment the tissues. This package allows the user to define regions based on ranges of density, and convert each region into a tissue type. Proceeding to subsequent layers the density range is repeated, so that large, well-defined organs or bone can be readily defined. This somewhat automated the process of converting from density to tissue type, but it was still a tedious process, requiring a trained anatomist. The height of the volunteer was 176.4 cm, which is quite close to the height of 176 cm of the average "reference" man [Snyder, et al.], so no scaling was done in the vertical direction. The weight of the volunteer was 64 kg, which was somewhat lower than the average weight of 71 kg [Snyder, et al.], so the horizontal voxels were scaled to 1.974 mm, in order to bring the weight of the segmented model to 70.93 kg.

Once a tissue-segmented model has been developed, the electrical properties of the tissues are defined. The properties of human tissue change significantly with frequency, so it is essential to use data accurately measured at the frequency of interest. There is a wide range of published data on measured tissue properties [Gabriel; Stuchly & Stuchly; Rush, et al.; Durney, et al.; Geddes & Baker; Foster & Schwan], and work is still underway to measure and verify these properties. The most complete measurements have been done by [Gabriel], and these measurements are being tested for repeatability by other groups [Davis]. In addition to the measured values at individual frequencies from 10 Hz through 20 GHz for 30 tissue types, the data in [Gabriel] were fit to a 4th order Cole-Cole equation, which provides a good interpolation for electrical properties of tissues at any specific frequency of interest. This Cole-Cole interpolation is assumed to be a good interpolation above 1 MHz, where the data is well-defined in the literature, and should be used with caution in the region below 1 MHz, where literature is still sparse.

As expected, the results from bioelectromagnetic simulations are significantly affected by the electrical properties of the tissues which are used [Gandhi, et al., 1996], so it is important to use properties measured as accurately as possible.

VI. Validation

The accuracy of the FDTD method has been extensively validated by comparing simulated results with analytical and measured results for sources in the far field coupled to a variety of geometries including square [Umashankar & Taflove] and circular [Umashankar & Taflove; Furse, et al., 1990; Taflove & Brodwin; Borup, et al.] cylinders, spheres [Holland, et al.; Gandhi & Chen, 1992; Sullivan, 1987; Gao & Gandhi], plates [Taflove, et al., 1985], layered half spaces [Oristaglio & Hohmann], and complicated geometries such as airplanes [Kunz & Lee]. Figure 5 shows the comparison for the electric fields calculated inside a 20-cm diameter sphere made up of 2/3 muscle irradiated by a plane wave at 200 MHz. The FDTD calculations are compared to the analytical solution based on the Bessel function expansion.

Figure 5: Magnitude of E_z along the y -axis of a 2/3 muscle sphere at 200 MHz. The plane-wave is incident from the y -direction. [Furse, et al., 1994]

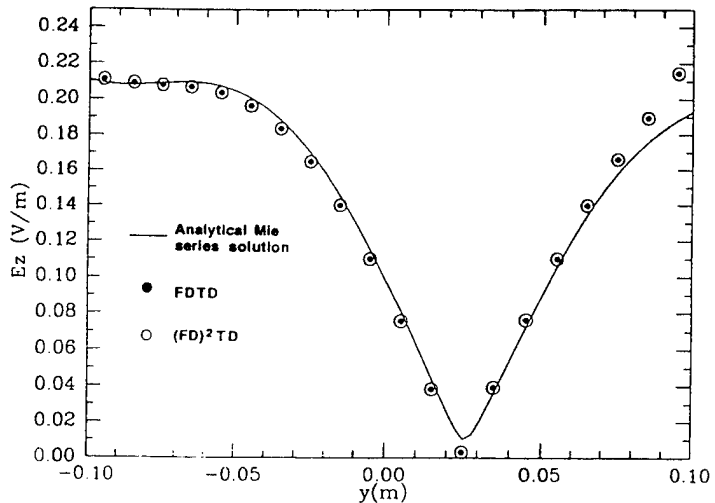

In addition to these far-field validations, several near-field validations have also demonstrated that the FDTD method can be used to accurately model localized sources very near the human body. [Furse and Gandhi] One such example is the modeling a Hertzian (infinitesimal) dipole at 900 MHz located 1.5 cm from a 20-cm diameter brain-equivalent ($\epsilon_r=43.0$, $\sigma = 0.83$ S/m) sphere. This is a very near-field simulation of a curved (spherical) model. The infinitesimal dipole is modeled as a single Ez source location, and is excited with a ramped sinusoidal source where

$$E_z(\text{feedpoint}) = [1 - \cos(\omega t)] \sin(\omega t) \quad \text{for } 0 \leq t \leq T$$

$$= \sin(\omega t) \quad \text{for } t \geq T$$

where T is the period of the sine wave. This ramped sine wave has been shown to reduce high-frequency transients [Beuchler, et al.] and DC offsets [Furse, 1994] sometimes associated with unramped sine waves. The cubical cell size is $\Delta = 5$ mm, which makes the sphere 40 cells in diameter. Figure 6 [Furse, et al., 1996] shows the relative SAR along the y-axis from the front edge of the sphere calculated using the FDTD method and compared to an analytical solution based on the Bessel function expansion [Dhondt & Martens].

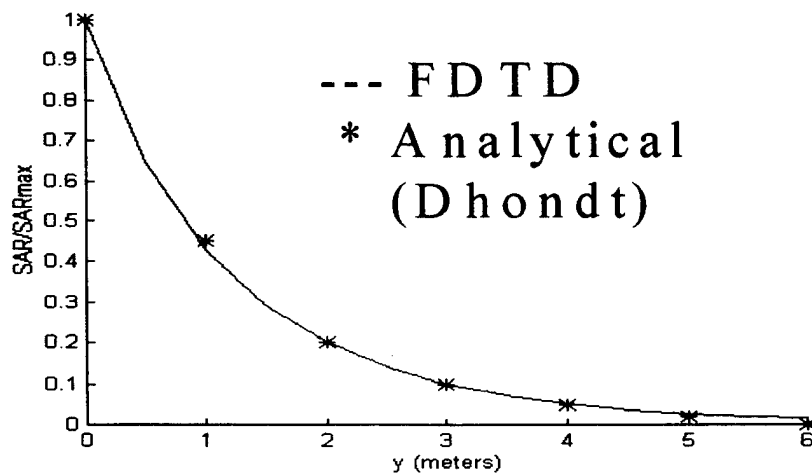

Figure 6: Relative SAR distribution along the y-axis of a homogeneous brain-equivalent sphere excited by an infinitesimal dipole. Analytical solution from [Dhondt and Martens]. FDTD from [Furse and Gandhi, 1996]

VII. Calculation of SAR, currents, and 1-gram SAR, and temperature

The FDTD method calculates the time-domain vector \mathbf{E} and \mathbf{H} fields at every location inside and outside of the body. These can be converted to frequency domain fields (magnitude and phase at given frequencies) using the methods described in section IV. Values commonly of interest in bioelectromagnetic simulations are specific absorption rate, current density, total power absorbed, temperature rise, etc.

Specific absorption rate (SAR) at a given location is given by:

$$SAR(i, j, k) = \frac{\sigma(i, j, k)|E|^2}{2\rho(i, j, k)} \quad (18)$$

where $\sigma(i,j,k)$ is the electrical conductivity and $\rho(i,j,k)$ is the mass density at the location of interest. $|E|^2$ is the magnitude of the electric field at the location of interest. Since the E_x, E_y, E_z components of this field are offset throughout the cell as shown in Figure 1, this requires that they be averaged to obtain the $|E|$ at exactly the location of interest. For instance, if the SAR is desired at the bottom left corner of the cell, $|E|$ is computed thus:

$$\begin{aligned} E_x(\text{corner}) &= [E_x(i,j,k) + E_x(i-1,j,k)] / 2. \\ E_y(\text{corner}) &= [E_y(i,j,k) + E_y(i,j-1,k)] / 2. \\ E_z(\text{corner}) &= [E_z(i,j,k) + E_z(i,j,k-1)] / 2. \\ |E|^2 &= E_x(\text{corner})^2 + E_y(\text{corner})^2 + E_z(\text{corner})^2 \end{aligned}$$

The 2 in the denominator of (18) converts the magnitudes of $|E|$ calculated from FDTD from peak values to RMS. This precision in calculating $|E|$ at a particular location in the cell is of minimal importance in far-field applications where the fields are not changing too rapidly within the cell. In near-field applications, such as analysis of cellular telephones, however, this is significant, as the fields are varying rapidly with the cells.

For near-field applications, such as cellular-telephones, numerical simulation is often used to determine if these devices comply with the ANSI/IEEE safety guidelines [ANSI] and newly-mandated FCC guidelines [FCC] which state that an exposure can be considered to be acceptable if it can be shown that it produces SAR's "below 0.08 W/kg, as averaged over the whole body, and spatial peak SAR values not exceeding 1.6 W/kg, as averaged over any 1 g of tissue (defined as a tissue volume in the shape of a cube)" [ANSI]. Because of the irregular shape of the body (eg. the ears) and tissue heterogeneities, a tissue volume in the shape of a cube of say, 1x1x1 cm will have a weight that may be in excess of, equal to, or less than 1 gram. Larger or smaller volumes in the shape of a cube may, therefore, need to be considered to obtain a weight of about 1 gram. Furthermore, for an anatomic model with parallelepiped voxels (such as the 1.974 x 1.974 x 3mm voxels of the University of Utah model), it is not very convenient to obtain exact cubical volumes even though nearly cubic shapes may be considered. It is therefore desirable to take volumes as close to cubical as possible (such as 5x5x4 and 6x6x3 voxels for this model), and to consider volumes with weights above 1 gram. In addition, rather than averaging the individual SAR values in each of these volumes (since significant portions are likely to be in air because of the irregular shape of the body), it is better to obtain the 1-gram averaged SAR by dividing the total power absorbed in the volume by the total weight of that volume. When a result has been obtained, it is further necessary to carefully scrutinize that volume, and also neighboring volumes, to be certain that the volume is inside the body as much as possible, and that the amount of external air included in the volume is minimized, given the irregular shape of the body [Gandhi, et al., 1996].

Another factor of interest in bioelectromagnetic simulations is the current or current density. The vertical current density is calculated:

$$J_z(i, j, k, t) = \frac{\partial D_z(i, j, k, t)}{\partial t} = \sigma(i, j, k)E_z(i, j, k) + \epsilon_o \epsilon_r(i, j, k) \frac{\partial E_z(i, j, k)}{\partial t} \quad (19)$$

where the derivatives are calculated numerically using (5b). Horizontal current densities are found similarly, and current is found by multiplying by the area. Total current passing through a layer is commonly reported, because this can be compared with experimental results [Gandhi & Chen, 1992].

VII. Computational Issues

A. Truncated Models

As progressively finer resolution models are used, the amount of required computer memory expands dramatically. For a doubling of resolution (cutting the cell size in half), eight times as much memory is required. In general, this higher resolution is required for higher frequencies, which are known to have minimal penetration into the body. In particular, for cellular telephones, the distal side of the head is almost completely shielded from the telephone. It is therefore possible to reduce the problem size to half or less of the original problem size by truncating the model. This is done with an efficient truncation scheme [Lazzi & Gandhi; Gandhi, et al., 1996]. Because of the minuscule coupling of the far side of the head to the telephone, a second, identical source (telephone) can be placed on the opposite side of the head, leaving the problem unaltered, provided that this second telephone is devoid of RF power (unfed). This model of the two sources, one fed and the other unfed, can be modeled using superposition of two simulations. The first (even) simulation models both sources as positively fed, and the second (odd) simulation models both sources fed, but with the first positively fed, and the second negatively fed. When the two simulations are superimposed, the first source is represented as positively fed, and for the second source, the positive and negative feeds cancel out, and the source is unfed.

The even simulation, which models both phones as positively fed, can be reduced in size by placing a perfect magnetic conductor in the center of the simulation. The odd simulation, which models one phone as positively fed and the other as negatively fed, can be reduced in size by placing a perfect electric conductor in the center of the simulation. Thus, both the even and odd simulation are half as large as originally modeled, so the memory requirement to run them is half of the original problem. In addition, if the power deposition from a single (fed) telephone reaches less than half way into the head, say less than 1/3 of the way into the head, the problem size can be reduced even further. Instead of placing the magnetic and electric conductors in the center of the problem, they are placed 1/3 of the way through the head. To check the validity of this approach, several test cases, including spheres, layered spheres, etc. were considered for an assumed

radiation frequency of 1900 MHz. Excellent agreements were obtained for the SAR distributions from the full, half, and 1/3 models.

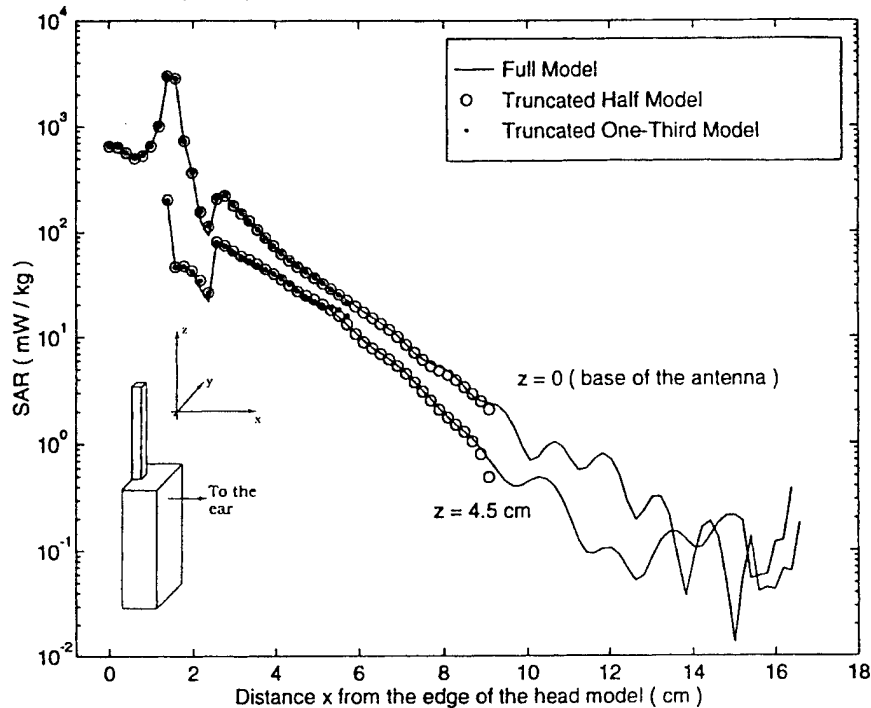

Figure 7 [Gandhi, et al., 1996] shows the SAR distributions obtained for an MRI-based model of the human head for which a quarter-wave monopole over a box is placed against the left ear. The SAR distributions are shown for the whole model, the truncated half model, and the truncated 1/3 model in the plane containing the base of the antenna, and $z=4.5$ cm above this plane. Minimal error is observed.

The steps to run this truncation method are:

- 1) Pick a plane of symmetry. This is generally chosen to be beyond the penetration of the fields, but can actually be within the field region itself, if errors near this symmetry plane can be tolerated.
- 2) Even simulation: Place a perfect magnetic conductor at the symmetry plane. This is programmed by setting the tangential magnetic fields = 0 on the symmetry plane. Run an FDTD simulation and store the complex values of all fields of interest from this simulation.
- 3) Odd simulation: Place a perfect electric conductor at the symmetry plane. This is programmed by setting the tangential electric fields = 0 on the symmetry plane. Run an FDTD simulation and store the complex of all fields of interest from this simulation.
- 4) Superposition: Add the stored complex values of all fields of interest.

Note: If the only data of interest is in the high field region near the source, either the even or odd simulation alone is generally sufficient. The superposition is required to improve accuracy near the truncation boundary.

B. Convolution Method

The simple convolution technique is very useful in FDTD and (FD)²TD simulations [Chen, et al., 1994]. To apply this technique, the impulse response of the man model is calculated using the complete simulation method, and is stored for later use. When the response of the body to a specific waveform is desired, the impulse response is convolved with the desired waveform to obtain the response of the body to that waveform. This convolution requires far less computational effort than rerunning the complete simulation with the new waveform. These are the steps for the convolution method:

1a) Choose an incident impulse waveform $I_{inc}(t)$ which has a frequency spectrum $\mathfrak{F}(I_{inc}(t))$ which contains all of the frequency components of interest. An ideal incident impulse is a rectangle function:

$$I_{inc}(t) = \begin{cases} 1 & \text{for } 0 \leq t \leq 5\Delta t \\ 0 & \text{for } t > 5\Delta t \end{cases} \quad (20)$$

which has the frequency spectrum $\mathfrak{F}(I_{inc}(t)) = 1$ for all frequencies. The frequencies in this pulse which are above the limit of the FDTD grid are dispersed. They do not propagate, and they do not cause aliasing errors in the FDTD simulation, as discussed in section II.

Alternatively:

1b) Use a series of continuous sine waves (CW) at each frequency of interest as the incident waveform, $I_{inc}(t)$. Combine their Fourier Transforms to find $\mathfrak{F}(I_{inc}(t))$.

2a) Run the (FD)²TD simulation using the incident impulse waveform $I_{inc}(t)$ as the source function. The (FD)²TD method is needed to properly model the frequency dispersion of the tissues over a broad band. Store impulse response of the simulation, $I_{res}(t)$. This may be the field component(s) at a given location, the current, power absorbed, or any other value which can be measured as a function of time. Calculate the frequency spectrum of the impulse response, $\mathfrak{F}(I_{res}(t))$.

Alternatively:

2b) Run the FDTD simulation using single-frequency simulations at each frequency in the band of interest with appropriate tissue properties at each frequency. Superimpose them to obtain $\mathfrak{F}(I_{res}(t))$.

3) Specify the desired incident waveform $I_{des}(t)$ and calculate its frequency spectrum, $\mathfrak{F}(I_{des}(t))$.

4) Find the frequency response of the simulation to the desired waveform:

$$\mathfrak{I}(I_{des_res}(t)) = \frac{\mathfrak{I}(I_{des}(t))\mathfrak{I}(I_{res}(t))}{\mathfrak{I}(I_{inc}(t))} \quad (21)$$

and find the time domain response of the simulation to the desired waveform:

$$I_{des_res}(t) = \mathfrak{I}^{-1} \left[\frac{\mathfrak{I}(I_{des}(t))\mathfrak{I}(I_{res}(t))}{\mathfrak{I}(I_{inc}(t))} \right] \quad (22)$$

VIII. Examples of Applications

A. Low Frequency (below 1 MHz)

The biggest limitation of FDTD for low frequency simulations has been that for typical resolutions each cycle has a huge number of time steps, and it is prohibitive to run even a single cycle. For 1mm resolution, for instance, using $\Delta t = \Delta x / (2c)$ a 60 Hz wave has 10^{10} time steps. This problem was first overcome by [Gandhi & Chen, 1992] using the method of frequency scaling [Guy, et al., 1982]. Frequency scaling observes that in a quasi-static simulation, the simulation can be run at a slightly higher frequency (f' still in the quasi-static range) than the actual frequency of interest (f), and the results can be linearly scaled to the lower frequency using

$$\mathbf{E}(f) = \frac{f}{f'} \mathbf{E}'(f') \quad (23)$$

The simulation is run using the tissue properties at frequency f , so that no scaling of the tissue properties is required. In [Gandhi & Chen, 1992] the FDTD frequency $f' = 10$ MHz was used, and scaled to $f = 60$ Hz. A single cycle (4580 time steps) of the 10 MHz wave was used with peak detection to find the magnitudes of the fields and calculate the total vertical current passing through each layer for comparison with measured values [DiPlacido, et al.], as shown in Figure 8 [Gandhi & Chen, 1992].

A more modern method of obtaining the magnitudes of the fields is to use the method described in (17). For low frequency simulations, the simulation is generally observed to converge in far less than a single cycle (because the body is miniscule compared to a wavelength), and the magnitude can be found by running the simulation only until convergence is reached (a small fraction of a cycle), and using the method in (17) to calculate the magnitudes. There can still be difficulties with numerical roundoff errors in the calculation of the magnitudes, because the waveform is radically oversampled. Frequency scaling significantly reduces the roundoff errors, by reducing the sampling of the waveform. Using a 10 MHz waveform instead of a 60 Hz waveform, for instance, gives a sampling of 60,000 time steps per cycle rather than 10^{10} time steps per cycle. An additional reduction in roundoff error can be obtained by choosing the two time steps, t_1 and t_2 reasonably far apart. The least error will occur when the time steps are a quarter wavelength apart, but far less is sufficient. Using 100 time steps between t_1 and t_2 gives roundoff errors on the order of 10^{-6} at 10 MHz, and this is generally more than sufficient for dosimetric calculations. An additional reason to use frequency scaling for

low frequency simulations is that the field values inside the body decrease linearly with frequency following (23), so that at low frequencies, the fields penetrating into the body are substantially lower than on the outside of the body. This causes significant roundoff errors in the FDTD calculations, which can again be avoided by using frequency scaling.

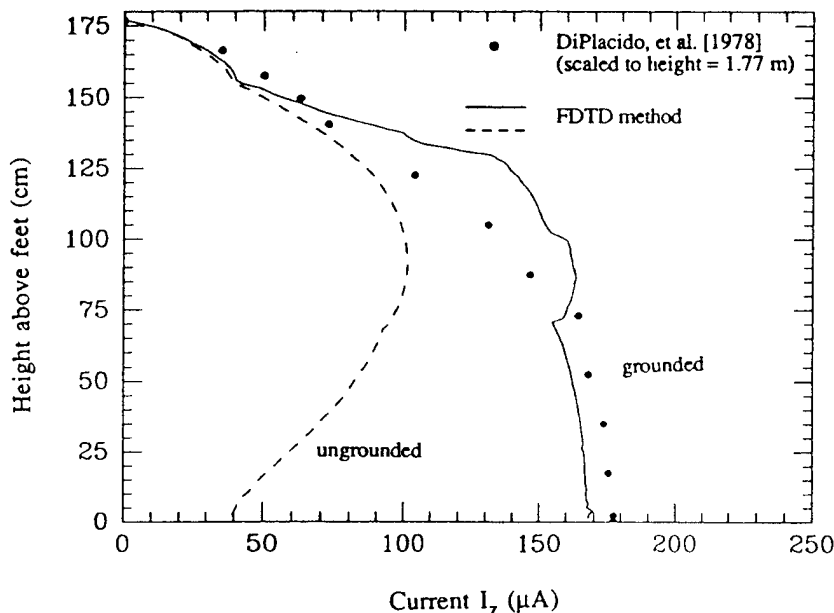

Figure 8: Calculated layer currents for saline-filled grounded and ungrounded human models exposed to a vertical 10 kV/m, 60 Hz electric field. For the FDTD techniques, $H_{inc} = 26.5$ A/m oriented from side-to-side of the body has also been included. Measured values are given in [DiPlacido, et al.], calculated values given in [Gandhi & Chen, 1992]

Another issue in low-frequency simulations is the absorbing boundary conditions. The PML boundary condition has been shown to be effective (errors less than 5%) at low frequencies, if the number of time steps is minimized. Mur boundary conditions, perhaps surprisingly, do not completely break down but are slightly less accurate than the PML conditions [De Moerloose, et al.].

B. Mid-Frequency (1 MHz - 1 GHz)

The FDTD method has been applied to a myriad of mid-frequency simulations including calculation of SARs and induced currents in the human body for plane wave exposures [Gandhi, et al., 1992], exposure to the leakage fields of parallel-plate dielectric heaters [Chen & Gandhi, 1991a], exposure to EMP [Chen & Gandhi, 1991b], annular phased arrays of aperture, dipole, and insulated antennas for hyperthermia [Chen & Gandhi, 1992], coupling of the cellular telephones to the head [Gandhi, et al., 1996; Jensen & Rahmat-Samii; Dimbylow & Mann; Luebbers, et al., 1992; Okoniewski & Stuchly; Watanabe, et al.], and exposure to RF magnetic fields in magnetic resonance imaging

(MRI) machines [Gandhi, et al., 1994]. Tissue properties and human models are well-established in this frequency band, and the FDTD method is a well-accepted simulation method in this range.

Simulations of the coupling of cellular telephones to the head has shown that the head absorbs 40-50% of the power radiated from an isotropic antenna such as is commonly used on cellular phones [Gandhi, et al., 1996], and that consequently the head significantly alters the radiation patterns from these phones [Jensen & Rahmat-Samii; Okoniewski & Stuchly] and also the matching characteristics of the antenna. The cellular telephones are generally modeled as a metal box covered by plastic. The size of this box has been shown to influence the radiated fields and SAR distribution patterns [Gandhi, et al., 1996]. In addition, the plastic covering the box and antenna also affects these parameters. Since the plastic is generally thinner than the resolution of the FDTD grid, an effective dielectric constant is used in this cell to model the plastic [Gandhi, et al., 1996]. This effective dielectric constant, K_e , is derived by noting that the electric fields close to a metallic surface such as that of a handset are primarily normal to the metal, and only a part of the FDTD-cell width is actually filled with the dielectric material. The required continuity of the normal component of $\mathbf{D}=\epsilon\mathbf{E}$ with the outer region can be used to obtain K_e . This gives an equation for K_e in an FDTD cell of size δ which is somewhat lower than the dielectric constant of the plastic, ϵ_r , of thickness w (generally about 1mm)

$$K_e = \frac{\delta / \epsilon_r}{[\epsilon_r (\delta - w) + w]} \quad (24)$$

Here δ is the dimension of the FDTD cell, which is δ_x , δ_y , δ_z depending on which surface of the metal handset or antenna is being considered.

Elements of cellular telephone simulations which have been found to significantly affect the accuracy of the simulation include the size of the metal box of the telephone and the dielectric properties used for the head [Gandhi, et al., 1996]. It has been shown that several different head models (with ears removed) can provide similar results, although homogeneous models have been found to significantly overestimate the 1-gram SAR value (by roughly 30%) [Gandhi, et al., 1996; Hombach, et al.]. Although [Hombach, et al.] did not consider the effect of ear shape, it is likely that the shape of the ear (pressed against the head or not pressed against the head) does affect the local SAR distribution. Two of the most significant parameters affecting the power deposition in the head from the cellular telephone is the nature of the antenna (length, shape, etc.) and how close it is to the head. For accurate modeling, it is essential to properly represent the length of the antenna, the exact configuration of the feedpoint (especially if any metal parts such as those used to hold the antenna protrude above the top of the box), and the exact location of the antenna on the top of the box. This can be done with engineering drawings or xrays of the actual phone. For accuracy, it is a good idea to model the telephone without the head first, and compare to a known measured value such as radiation pattern or near-field measurements without the head, to ensure that the model of the telephone and antenna is accurate. Once the telephone model is verified, there is still the question of how to position the telephone relative to the head. This has been done several different ways in

the literature. One school of thought is to find the absolute worst position the phone could be held in, such as directly in front of and nearly touching the eye. Another school of thought is to position it in approximately the position it would be used, but without the ear, as the ear significantly complicates both measurements and interpretation of the measurements [Gandhi, et al., 1996]. Still another school of thought is to attempt the most realistic placement for ordinary operation of the phone, including the effect of the ear [Lazzi & Gandhi, 1996]. In this case, the ear is compressed as it generally is when people press the phone against their ear. Care is taken to line up the listening microphone with the ear canal, as this is observed to be the position where the phone is generally used. The effect of tilting the telephone towards the mouth, in the most realistic position, has also been examined [Lazzi & Gandhi, 1996]. In this case, the telephone is modeled on the vertical FDTD grid, and the head is tipped, to prevent errors due to stair-case modeling of the metal phone parts.

As an example of the effect of these parameters, Table 1 shows a comparison of several different orientations of the head for a 2.76 x 5.73 x 15.5 cm telephone at 835 MHz, covered with 1 mm of plastic (modeled as one cell thick using (24)), with a $\lambda/4$ antenna, also coated with plastic. The phone model is held against the Utah model of the human head, and the simulation has an overall resolution of 1.974 x 1.974 x 3mm. Three values are shown, one for the phone held vertical to the head, touching the ear, which is pressed against the head. The second model has the phone tilted towards the mouth, but not pressed against the cheek, and the third model has the phone tilted towards the mouth and pressed against the cheek. As the phone is tilted towards the mouth, the antenna is effectively tilted away from the head, thus lowering the localized values very near the antenna, and consequently the 1-gram SAR value. This effect is most notable for physically long antennas. For the shorter antenna used at 1900 MHz, the 1-gram SAR is not lowered significantly as the phone is tilted. This is because the antenna remains very near the head, despite being tilted

Table 1: Comparison of the 1-gram SARs for a cellular telephones next to the head as a function of phone position [Lazzi and Gandhi, 1996]

Frequency (MHz)	Vertical Head Model	Tilted 30 degrees head Model	Tilted 30 degrees head model with additional rotation of 9 degrees
835	2.93 W/kg	2.44 W/kg	2.31 W/kg
1900	1.11 W/kg	1.08 W/kg	1.20 W/kg

C. High Frequency (above 1 GHz)

The use of the FDTD method for high frequency simulations is limited only by the resolution of the grid and the ability of the computer to analyze the very large models which result from small grid resolutions. Fortunately, at high frequencies, the power deposition is highly superficial, so methods such as truncating the model [Lazzi & Gandhi, 1996] are highly effective. This method has been used for cellular telephones working at 6 GHz [Gandhi and Chen, 1995]

D. Broad-Band

Since the properties of biological tissue are significantly frequency dispersive, one of two methods must be used to predict broad-band effects. Either the convolution method must be used, where individual FDTD simulations are run at every frequency of interest (where tissue properties can be precisely prescribed), as described in section II, or the $(FD)^2TD$ method should be used as described in section III. The convolution method is very cumbersome if a large number of frequencies are of interest. The relative accuracy of the two methods depends on the accuracy of the Debye equation (13) fits to the measured tissue properties. If the match is perfect, the two methods provide identical accuracy. If the match has some error, the error observed in the $(FD)^2TD$ simulation is the same as would have occurred if the FDTD simulation had been run with that error in the tissue properties. In general, truly broad-band simulations have such a large number of frequencies in the pulse that the $(FD)^2TD$ is preferable to multiple FDTD simulations.

As an example, the FDTD and $(FD)^2TD$ methods were compared for finding the layer-averaged SARs in a 1.31 cm resolution model of the human body over the frequency range from 20 to 915 MHz [J.Y. Chen, et al., 1994]. Figure 9 shows the layer-averaged RF current at 40, 150, and 350 MHz for this simulation.

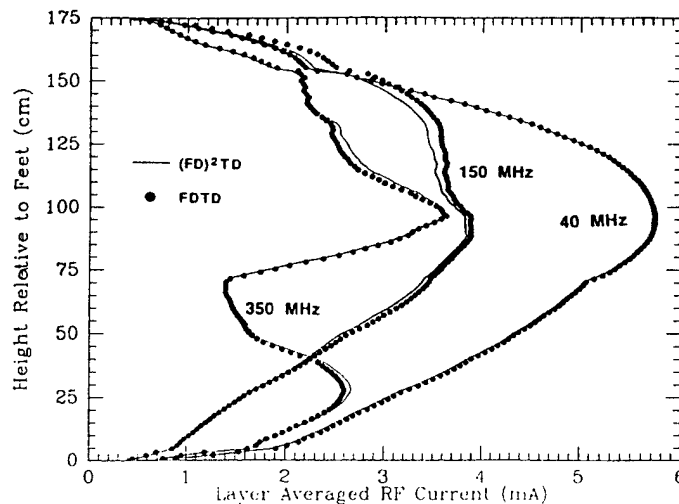

Figure 9: Layer-averaged RF currents in the human model comparing the accuracy of the FDTD and $(FD)^2TD$ solutions. Tissue properties are modeled with second-order Debye equations.

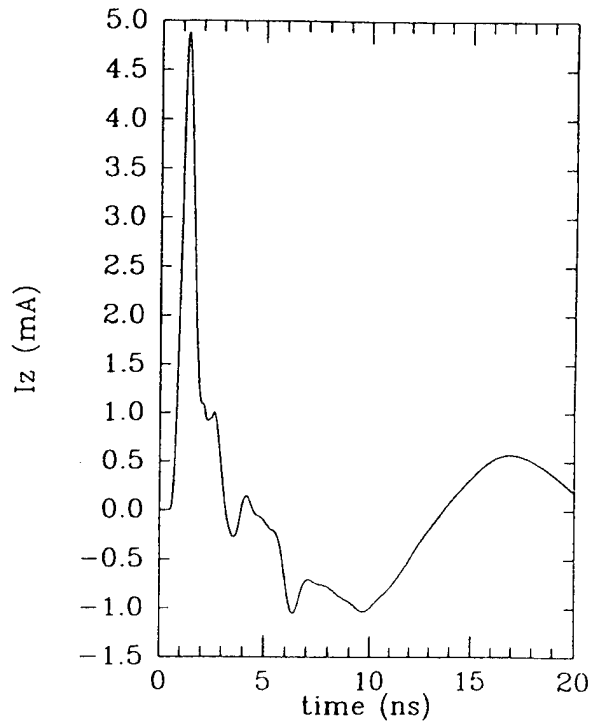

Figure 10: Time-domain currents through the heart, simulated using the $(FD)^2TD$ method.

The results of the $(FD)^2TD$ simulation are shown in Figure 10 in the time-domain for a raised-cosine pulse which has a bandwidth from 0 to 915 MHz. The layer-averaged current is shown for the layers of the eyes and the ankles. This broad-band time-domain simulation would have been prohibitively cumbersome to obtain without the $(FD)^2TD$ method because of the large number of frequencies in this pulse.

V. Conclusions

The FDTD method has proven to be one of the most flexible, efficient, and applicable methods for numerical calculations of electromagnetic interaction with the body from the quasi-static to near-optic range. It lends itself particularly well to modeling the heterogeneities of the human body in millimeter resolution, and to modeling a wide variety of electromagnetic sources in the far field or very near the body. In addition to the basic efficiency of the algorithm, numerous additions to the method make the application of this method even more efficient for particular applications. The FDTD algorithm is efficiently programmed for either serial or parallel machines, and is found to scale very near linearly as the number of processors is increased. Methods to reduce the model size such as grid truncation have been shown to be highly effective. Signal processing techniques can be optimized for this method, and a frequency-dependent FDTD method provides data for

broad-band simulations. The flexibility and efficiency of this simple algorithm have made it the popular electromagnetics simulation method that it is.

REFERENCES

- ANSI/IEEE C95.1-1992, "American National Standard --- safety levels with respect to exposure to radio frequency electromagnetic fields, 3 kHz to 300 GHz," published by the Institute of Electrical and Electronic Engineers, Inc., 345 East 47th Street, New York, New York, 10017
- Bi, Z., Y. Shen, K. Wu, J. Litva, "Fast finite-difference time-domain analysis of resonators using digital filtering and spectrum estimation techniques," *IEEE Trans. Microwave Theory and Tech.*, pp. 1611-1619, 1992
- Borup, D.T., D.M. Sullivan, O.P. Gandhi, "Comparison of the FFT conjugate gradient method and the FDTD method for the 2D absorption problem," *IEEE Trans. Microwave Theory and Tech.*, pp. 383-395, 1987
- Bui, M.D., S.S. Stuchly, G.I. Costache, "Propagation of transients in dispersive dielectric media," *IEEE Trans. Microwave Theory and Tech.*, Vol. MTT-39, pp. 1165-1172, July 1991
- Chen, J.Y., O.P. Gandhi, D.L. Conover, "SAR and induced current distributions for operator exposure to RF dielectric sealers," *IEEE Trans. Electromagnetic Compatibility*, 33(3), pp. 252-161, 1991
- Chen, J.Y., O.P. Gandhi, "Currents induced in an anatomically based model of a human for exposure to vertically polarized electromagnetic pulses," *IEEE Trans. Microwave Theory and Techniques*, 39(1), pp. 31-39, 1991
- Chen, J.Y., O.P. Gandhi, "Numerical simulation of annular-phased arrays of dipoles for hyperthermia of deep-seated tumors," *IEEE Trans. Biomed. Eng.*, 39(3), pp. 209-216, 1992
- Davis, C.C., G. A. Katona, L.S. Taylor, "Dielectric measurement of tissues in the mammalian head at cellular telephone frequencies," 18th Annual meeting of the Bioelectromagnetics Society, Victoria, B.C., June 9-14, 1996
- De Moerloose, J., T.W. Dawson, M.A. Stuchly, "Application of FDTD to quasi-static field analysis," personal communication
- Deno, D.W. "Currents induced in the human body by high voltage transmission line electric field - measurement and calculation of distribution and dose," *IEEE Trans. Power Apparatus and Systems*, Vol. PAS-96 (5), pp. 1517-1527, Sept./Oct. 1977

Dhondt, G., L. Martens, "A canonical case with an analytical solution for the comparison of electromagnetic field solvers," Proceedings of the COST 244 meeting on Reference Models for Bioelectromagnetic Test of Mobile Communication Systems, D. Suminic, Editor

Dimbylow, P.J., and S. M. Mann, "SAR Calculations in an Anatomically Based Realistic Model of the Head for Mobile Communication Transceivers at 900 MHz and 1.8 GHz," *Physics in Medicine and Biology*, Vol. 39, pp. 1537-1553, 1994

Dimbylow, P.J., "The development of realistic voxel phantoms for electromagnetic field dosimetry," *Voxel Phantom Development: Proceedings of an International Workshop held at the National Radiological Protection Board*, Chilton, UK, July 6-7, 1995, Peter J. Dimbylow, editor

DiPlacido, J., C.H. Chih, B.J. Ware, "Analysis of the proximity effects in electric field measurements," *IEEE Trans. Power Apparatus Systems*, Vol. 97, pp. 2167-2177, 1978

Durney, C.H., C.C. Johnson, P.W. Barber, H. Massoudi, M.F. Iskander, J.L. Lords, D.K. Ryser, S.J. Allen, J.C. Mitchell, *Radiofrequency Radiation Dosimetry Handbook*, 2nd ed., USAF School of Medicine, Brooks AFB, TX, 1978

FCC 96-326, "Guidelines for evaluating the environmental effects of radiofrequency radiation," Aug. 1, 1996, available from the Federal Communications Commission, Washington, D.C. 20554

Foster, K.R., H. Schwan, Table 5, *Critical Reviews in Biomedical Engineering*, Vol. 17(1), pp. 25-104, 1989

Furse, C.M. "Use of the FDTD method for broad band calculations of electromagnetic scattering and absorption from large, heterogeneous scatterers," PhD Dissertation, University of Utah, 1994

Furse, C.M., J.-Y. Chen, O.P. Gandhi, "The use of the frequency-dependent finite-difference time-domain method for induced current and SAR calculations for a heterogeneous model of the human body," *IEEE Trans. Electromagnetic Compatibility*, 36(2), 128-133, 1994

Furse, C.M., S.P. Mathur, O.P. Gandhi, "Some improvements to the FDTD method for calculating radar cross section of a perfectly conducting target," *IEEE Trans. Microwave Theory and Tech.*, Vol. 38, pp. 919-927, 1990

Furse, C.M., O.P. Gandhi, "Calculation of Electric Fields and Currents Induced in a mm-Resolution Human Model with a Novel Time-to-Frequency Domain Conversion," IEEE Antennas and Propagation Society Conference, Baltimore, MD, July 21-25, 1996

Gabriel, C., "Compilation of the dielectric properties of body tissues at RF and microwave frequencies," Final Report AL/OE-TR-1996-0037 submitted to Occupational and Environmental Health Directorate, RFR Division, 2503 Gillingham Dr., Brooks AFB, TX, June 1996

Gandhi, O.P., J.Y. Chen, "Numerical dosimetry at power-line frequencies using anatomically-based models," *Bioelectromagnetics Supplement I*, pp. 43-60, 1992

Gandhi, O.P., Y.G. Gu, J.Y. Chen, H.I. Bassen, "Specific absorption rates and induced current distributions in an anatomically based human model for plane-wave exposures," *Health Physics*, 63(3), pp. 281-290, 1992a

Gandhi, O.P., B.Q. Gao, J.Y. Chen, "A frequency-dependent finite-difference time-domain formulation for induced current calculations in human beings," *Bioelectromagnetics*, Vol.3, pp. 47-71, 1992b

Gandhi, O.P., B.Q. Gao, J.Y. Chen, "A frequency-dependent finite-difference time-domain formulation for general dispersive media," *IEEE Trans. Microwave Theory and Tech* 41(4), pp. 658-665, 1993a

Gandhi, O.P., C.M. Furse, "Currents induced in the human body for exposure to ultrawideband electromagnetic pulses," Final Report AI-TR-1992-0156 to Occupational and Environmental Health Directorate, RFR Division, Brooks AFB, TX, May 1993

Gandhi, O.P., S.B. Chen, X.Yuan, J.Y. Chen, "Dosimetry for time-varying magnetic fields in MR Imaging," p. 16, *Abstracts of Sixteenth Annual Meeting of the Bioelectromagnetics Society*, Copenhagen, Denmark, June 12-17, 1994

Gandhi, O.P. "Some experimental methods for dosimetry: Extremely low frequencies to microwave frequencies," *Radio Science*, 30(1), 161-177, 1995

Gandhi, O.P., C.M. Furse, "Millimeter-resolution MRI-based models of the human body for electromagnetic dosimetry from ELF to microwave frequencies," *Voxel Phantom Development: Proceedings of an International Workshop held at the National Radiological Protection Board*, Chilton, UK, July 6-7, 1995, Peter J. Dimbylow, editor

Gandhi, O.P., J.Y. Chen, "Electromagnetic absorption in the human head from experimental 6 GHz handheld transceivers," *IEEE Trans. Electromagnetic Compatibility*, 37(11), 547-558, 1995

Gandhi, O.P., J.Y. Chen, "Electromagnetic absorption in the human head from experimental 6 GHz hand-held transceivers," *IEEE Trans. Electromagnetic Compatibility*, Vol. 37, pp. 547-558, 1995

Gandhi, O.P., G.Lazzi, C.M. Furse, "Electromagnetic Absorption in the human head and neck for mobile telephones at 835 and 1900 MHz," *IEEE Trans. Microwave Theory and Tech.*, 44(10), Oct. 1996

Gao, B.-Q., O.P. Gandhi, "An expanding grid algorithm for the FDTD method," *IEEE Trans. Electromagnetic Compatibility*, pp. 277-283, 1992

Geddes, L.A., L.E. Baker, "The specific resistance of biological material – a compendium of data for the biomedical engineer and physiologist," *Med. & Biol. Engng.*, Vol. 5, pp. 271-293, Pergamon Press, 1967

Guy, A.W., S. Davidow, G.Y. Yang, C.K. Chou, "Determination of electric current distributions in animals and humans exposed to a uniform 60-Hz high-intensity electric field," *Bioelectromagnetics*, Vol.3, pp. 47-71, 1982

Holland, R., L. Simpson, K.S. Kunz, "Finite-difference analysis of EMP coupling to lossy dielectric structures," *IEEE Trans. Electromagnetic Compatibility*, pp. 203-209, 1980

Hombach, V., K.Meier, M. Burkhardt, E. Kuhn, N.Kuster, "The dependence of EM energy absorption upon human head modeling at 900 MHz," *IEEE Trans. Microwave Theory and Tech.*, 44(10), pp. 1865-1873, 1996

Jensen, M.A., Y. Rahmat-Samii, "EM interaction in handset antennas and a human in personal communications," *Proc. IEEE*, 83, pp.7-17, 1995

Joseph, R.M., S.C. Hagness, A. Taflove, "Direct time integration of Maxwell's equations in linear dispersive media with absorption for scattering and propagation of femtosecond electromagnetic pulses," *Optics Letters*, Vol 16(18), pp. 1412-1414, Sept. 1991

Kunz, K.S., K.M. Lee, "A three-dimensional finite-difference solution of the external response of an aircraft to a complex transient EM environment: Part II—Comparison of predictions and measurements," *IEEE Trans. Electromagnetic Compatibility*, pp. 333-341, 1978

Kunz, K.S., R.J. Luebbers, *The Finite-Difference Time-Domain Method in Electromagnetics*, CRC Press, Boca Raton, FL, 1993

Lazzi, G., O.P. Gandhi, "Realistically titled and truncated anatomically based models of the human head for dosimetry of mobile telephones," to be published in *IEEE Trans. Electromagnetic Compatibility*

Lee, C.F., R.T. Shin, J.A. Kong, "Application of FD-TD technique to dispersive materials," *PIERS Proceedings*, 1991

- Lin, J.C., O.P. Gandhi, "Computational methods for predicting field intensity," *CRC Handbook Biological Effects Electromagnetic Fields*, 2nd ed., C.Polk and E. Postow, Eds., CRC Press, Boca Raton, FL, ch. 9, pp. 335-339, 1995
- Luebbers, R., L.Chen, T. Uno, S. Adachi, "FDTD Calculation of Radiation Patterns, Impedance and Gain for a Monopole Antenna on a Conducting Box," *IEEE Trans. Antennas and Propagation*, Vol. 40, pp. 1577-1582, 1992
- Luebbers, R., F. Hunsberger, K. Kunz, "A frequency-dependent finite-difference time-domain formulation for transient propagation in plasma," *IEEE Trans. Antennas and Propagation*, pp. 29-34, 1991
- Luebbers, R., F. Hunsberger, K. Kunz, "FDTD for Nth order dispersive media," submitted to *IEEE Trans. Antennas and Propagation*, 1992
- Luebbers, R.J., F.P.Hnusberger, K.S. Kunz, R.B. Standler, M. Schneider, "A frequency-dependent finite-difference time-domain formulation for dispersive materials," *IEEE Trans. Electromagnetic Compatibility*, Vol. EMC-22, pp. 222-227, Aug. 1990
- Luebbers, R., L.Chen. T. Uno, S. Adachi, "FDTD calculation of radiation patterns, impedance, and gain for a monopole antenna on a conducting box," *IEEE Trans. Antennas and Propagation*, Vol. 40, pp. 1577-1582, 1992
- Okoniewski, Michal, M.A. Stuchly, "A study of the handset antenna and human body interaction," *IEEE Trans. Microwave Theory and Tech.*, 44(10), pp. 1855-1864, 1996
- Olley, P., P.S. Excell, "Classification of high resolution voxel image of a human head," *Voxel Phantom Development: Proceedings of an International Workshop held at the National Radiological Protection Board*, Chilton, UK, July 6-7, 1995, Peter J. Dimbylow, editor
- National Library of Medicine, Visible Man Project, MRI scans, CT scans, and photographs available on CD through Research Systems, Inc., 2995 Wilderness Place, Boulder, CO 80301
- Oristaglio, M.L., G.W. Hohmann, "Diffusion of electromagnetic fields into a two-dimensional earth: a finite-difference approach," *Geophysics*, pp. 870-894, 1984
- Rush, S., J.A. Abildskov, R. McFee, "Resistivity of body tissues at low frequencies," *Circ. Research*, Vol. XII, pp. 40-50, 1963
- Snyder, W.S., M.J. Cook, E.S. Nassset, L.R. Karhausen, G.P. Howells, I.H. Tipton, Report of the Task Group on Reference Man, Pergamon Press, 1995

Stuchly, M.A., S.S. Stuchly, "Dielectric properties of biological substances – tabulated," *J. Microwave Power*, 15(1), pp. 19-26, 1980

Stuchly, M.A., K. Caputa, A. van Wensen, A. El-Sayed, "Models of human and animal bodies in electromagnetics," *Voxel Phantom Development: Proceedings of an International Workshop held at the National Radiological Protection Board*, Chilton, UK, July 6-7, 1995, Peter J. Dimbylow, editor

Sullivan, D.M., "Use of the FDTD method in electromagnetic dosimetry," Ph.D. Dissertation, Chapter 1, University of Utah, 1987

Sullivan, D.M., "A frequency-dependent FDTD method for biological applications," *IEEE Trans. Microwave Theory and Tech.*, Vol. MTT-40, pp. 532-539, March 1992

Taflove, A., *Computational Electrodynamics: The Finite-Difference Time-Domain Method*, Artech House, Dedham, MA, 1995

Taflove, A., M. Brodwin, "Numerical solution of steady-state electromagnetic scattering problems using the time-dependent Maxwell's equations," *IEEE Trans. Microwave Theory and Tech.*, pp. 623-630, 1975

Taflove, A., K.R. Umashankar, T.G. Jurgens, "Validation of the FDTD modeling of the radar cross section of three-dimensional structures spanning up to nine wavelengths," *IEEE Trans. Antennas and Propagation*, pp. 662-666, 1985

Umashankar, K., A. Taflove, "A novel method to analyze electromagnetic scattering of complex objects," *IEEE Trans. Electromagnetic Compatibility*, pp. 397-424, Nov. 1982

Watanabe, S., M. Taki, T. Nojima, O. Fujiwara, "Characteristics of the SAR distributions in a head exposed to electromagnetic fields radiated by a hand-held portable radio," *IEEE Trans. Microwave Theory and Tech.*, 44(10), pp. 1874-1883, 1996

Yee, K.S., "Numerical solution of initial boundary problems involving Maxwell's equations in isotropic media," *IEEE Trans. Antennas and Propagation*, Vol. 41, pp. 302, 1966

BOOK REVIEW

Solving Problems on Concurrent Processors, Volumes 1 and 2

Publisher: Prentice Hall, 1988

Authors: I. Angus, G. Fox, M. Johnson, S. Otto, G. Lyzenga, D. Walker,
J. Salmon, and J. Kim

Reviewer: Ray Perez

Volume 1: General Techniques and Regular Problems

Volume 2: Software for Concurrent Processors

Introduction:

These two volumes were written about eight years ago when parallel computing was still in its early beginnings (as compared to today). Nevertheless, the information provided is as timely as it was then. In the last review of a book on parallel computing we examined one book that addressed the "generalities" and main "architectures" of parallel processing. There are other similar books in the market that also introduce parallel computing.

This review covers both volumes which focus on the nuts and bolts of parallel programming. These volumes are the result of experiences by the authors, not only in the development of a parallel processor (i.e. a hardware approach), but also in the programming. Actual examples are addressed, some of which are of significance in computational electromagnetics (e.g. LU factorization, matrix multiplication, etc).

Volume 1:

The first volume is the result of hardware and software research work performed in the early concurrent processors developed at the California Institute of Technology, known as the Hypercube. It contains 23 chapters as follows: 1) Well known concurrent processors; 2) General issues in concurrent computation; 3) A particular approach to concurrent computing; 4) A simple concurrent programming environment; 5) Introduction to decomposition and concurrent algorithms; 6) An approach to concurrent input/output problems; 7) Elliptic problems in two dimensions I; 8) Elliptic problems in two dimensions II; 9) Long range interactions; 10) Matrix algorithms I (matrix multiplication); 11) The fast fourier transform; 12) Monte Carlo methods; 13) Application of Monte Carlo methods; 14) CrOS (this is the hypercube operating system): Specific implementation of the programming environment; 15) CUBIX implementation issues; 16) Particle dynamics: Problems with slightly irregular communication structure; 17) An irregular distributed simulation problem; 18) Sorting on the hypercube; 19) Scalar products: mapping the hypercube into a tree; 20) Matrix algorithm II (banded matrix LU decomposition; 21) Communication strategies and general matrix algorithms; 22) General message passing in a loosely synchronous environment; and 23) The hypercube as a supercomputer in science and engineering. Volume 1 concentrates on practical model problems which serve to illustrate genetic algorithms and decomposition techniques. The problems addressed are typical of those for which straight forward techniques can yield good concurrent performance.

Chapter 1 illustrates in an effective matter the ideas of concurrency in many fields of regular everyday life (e.g. the brain is a concurrent processor).

Chapter 2 describes the technological driving forces, choices, and issues of the particular approach used in this book. The first three chapters form an overview of concurrent computation in scope similar to that previously addressed in the last book review.

Chapters 4, 5, and 6 contain simplified descriptions of a software environment, while introducing some of the basic algorithmic issues needed in parallel computing. The discussion is presented from a point of view of a "virtual machine" ignoring practical constraint which could arise from using any real hardware or software system.

Chapters 5 and 6 show examples of the numerical solution of a wave equation in both FORTRAN and C languages.

Chapters 7 through 13 explain several key examples involved in the numerical solution of partial differential equations, matrix problems, particle dynamics, fourier transforms, and Monte Carlo or statistical algorithms.

Chapter 14 presents a practical implementation in the hypercube environment including introduction of the hypercube operating system.

Chapter 15 continues with the same theme and is an extension of Chapter 16.

Chapter 16 is the first discussion of particle dynamics in the presence of a force.

Chapter 17 discusses the complicated problem of population dynamics. This example allows the discussion of load-balancing techniques that were first addressed in chapter 3.

In Chapters 18 and 19 sorting and tree algorithms are presented.

Chapters 20 and 21 discuss some of the most important matrix algorithms, specifically the case of solution of banded matrix equations. The methods developed in chapter 21 are used to extend the algorithms from chapter 19.

The techniques developed in Chapter 22 allow the implementation of a hardware independent virtual machine .

Chapter 23 describes how the hypercube can be used as a supercomputer in a wide variety of fields.

Volume 2:

The second volume is the software supplement containing a set of computer programs that explicitly realize the algorithms and software discussed in the main text. It focuses on software which implements the algorithms presented in volume 1.

Chapter 1 reviews the parallel hardware available at the time the book was written, and presents a survey of applications on several parallel machines.

Chapters 2 through 5 deal with the implementation of the hypercube operating system.

Chapter 6 describes a hypercube simulation.

Chapter 7 discusses tutorial systems that may be used for educational purposes or for developing concurrent applications to be run subsequently in large systems.

Chapter 8 is the core of Volume 2 describing sixteen (16) application codes in detail. Most of these applications are implementations of the algorithms described in volume 1. The C and FORTRAN codes are given in the appendices of Volume II.

Chapter 9 describes a series of benchmark programs which have been used previously to evaluate the performance of several advanced architectures.

Chapter 10 provides a discussion of the future of parallel processing in the year 2000. Appendices A and B contain listings of the complete FORTRAN and C source code of the applications addressed in chapter 8.

A tutorial is described in Volume 2, intended to help new users become familiar with the concurrent implementation of simple problems.

Appendices C and D contain C and FORTRAN source code listings for the exercises in the tutorial.

As stated earlier, some of the material in the book is tailored to the hypercube parallel computer but the subjects and background material are applicable to all parallel computers and such material is very well documented. Ample references are given throughout the book. These two volumes are suitable for those who want to get involved in software coding for parallel computing.

THE APPLIED COMPUTATIONAL ELECTROMAGNETIC SOCIETY

CALL FOR PAPERS

The 14th Annual Review of Progress in Applied Computational Electromagnetics

16-20 March, 1998

Naval Postgraduate School, Monterey, California

Share your knowledge and expertise with your colleagues

The Annual ACES Symposium is an ideal opportunity to participate in a large gathering of EM analysis enthusiasts. The purpose of the Symposium is to bring analysts together to share information and experience about the practical application of EM analysis using computational methods. The symposium offerings include technical presentations, demonstrations, vendor booths and short courses. All aspects of electromagnetic computational analysis are represented. Contact Jianming Jin for details.

The ACES Symposium is a highly influential outlet for promoting awareness of recent technical contributions to the advancement of computational electromagnetics. Attendance and professional program paper participation from non-ACES members and from outside North America are encouraged and welcome.

Technical Program Chairman

Jianming Jin
ECE Department
University of Illinois
1406 W. Green Street
Urbana, IL 61801-2991
Phone: (217) 244-0756
FAX: (217) 333-5962
Email: j-jin1@uiuc.edu

Symposium Administrator

Richard W. Adler
ECE Dept/Code EC/AB
Naval Postgraduate School
833 Dyer Road, Room 437
Monterey, CA 93943-5121
Phone: (408) 646-1111
FAX: (408) 649-0300
Email: rwa@ibm.net

Symposium Co-Chairman

Michael A. Jensen
ECE Dept., 459 CB
Brigham Young University
Provo, UT 84602
Phone: (801) 378-5736
FAX: (801) 378-6586
Email: jensen@ee.byu.edu

1998 ACES Symposium

Sponsored by:
in cooperation with:

ACES, NPS, DOE/LLNL, U of KY, U of IL, DOD, SIAM, NCCOSC and AMTA
The IEEE Antennas and Propagation Society, the IEEE Electromagnetic
Compatibility Society and USNC/URSI

THE APPLIED COMPUTATIONAL ELECTROMAGNETIC SOCIETY

CALL FOR PAPERS

The 14th Annual Review of Progress in Applied Computational Electromagnetics

Papers may address general issues in applied computational electromagnetics, or may focus on specific applications, techniques, codes, or computational issues of potential interest to the Applied Computational Electromagnetics Society membership. Area and topics include:

- Code validation
- Code performance analysis
- Computational studies of basic physics
- Examples of practical code application
- New codes, algorithms, code enhancements, and code fixes
- Computer Hardware Issues
- Partial list of applications:

antennas	wave propagation
radar imaging	radar cross section
shielding	bioelectromagnetics
EMP, EMI/EMC	visualization
dielectric & magnetic materials	inverse scattering
microwave components	MIMIC technology
fiberoptics	remote sensing & geophysics
communications systems	propagation through plasmas
eddy currents	non-destructive evaluation
- Partial list of techniques:

frequency-domain & time-domain techniques	
integral equation & differential equation techniques	
finite difference & finite element analysis	
diffraction theories	physical optics
modal expansions	perturbation methods
hybrid methods	moment methods

INSTRUCTIONS FOR AUTHORS AND TIMETABLE

For both summary and final paper, please supply the following data for the principal author: name, address, Email address, FAX, and phone numbers for both work and home.

October 26, 1997: Submission deadline. Submit four copies of a 300-500 word summary to the Technical Program Chairman.

November 25, 1997: Authors notified of acceptance

January 10, 1998: Submission deadline for camera-ready copy. The papers should not be more than 8 pages long including figures.

REGISTRATION FEE

Registration fee per person for the Symposium will be approximately \$255 for ACES Members; \$295 for non-members, \$115 for Student, Retired and Unemployed, does not include conference proceedings; or \$150 for Student/Unemployed/retired, which includes proceedings. The exact fee will be announced later. All Conference participants are required to register for the Conference and to pay the indicated registration fee.

SHORT COURSES

Short courses will be offered in conjunction with the Symposium covering numerical techniques, computational methods, surveys of EM analysis and code usage instruction. It is anticipated that short courses will be conducted principally on Monday March 16 and Friday March 20. Fee for a short course is expected to be approximately \$90 per person for a half-day course and \$140 for a full-day course, if booked before March 3, 1998. Full details of 1998 Symposium will be available by November 1997. Short Course Attendance is not covered by the Symposium Registration Fee!

EXHIBITS

Vendor booths and demonstrations will feature commercial products, computer hardware and software demonstrations, and small company capabilities.

PRELIMINARY AGENDA

The Thirteenth Annual Review of Progress in Applied Computational Electromagnetics

NAVAL POSTGRADUATE SCHOOL
17-21 MARCH 1997

Eric Michielssen, Technical Program Chairman

Jin-Fa Lee, Conference Co-Chair

Keith Whites, Short Course and Vendor Chairman

Robert Bevensee, Assistant Conference Co-Chair

Richard W. Adler, Conference Facilitator

MONDAY MORNING 17 MARCH 1997

0730-0820	SHORT COURSE REGISTRATION	Glasgow 103
0830-1630	SHORT COURSE (FULL-DAY) "Finite Elements for Electromagnetics", John Brauer & Zoltan Cendes, Ansoft Corp.	Glasgow 102
0830-1630	"SHORT COURSE (FULL-DAY) "Ray-Tracing Techniques for the Prediction of Propagation Parameters in Mobile Communications. to Applications Microcells and Picocells", Felipe Catedra, University of Cantabria	Ingersoll 122
0830-1630	SHORT COURSE (FULL-DAY) "Transmission Line Matrix (TLM) Modeling of Electromagnetic Fields in Space and Time" Wolfgang J.R. Hoefler, University of Victoria	Engr. Auditorium
0830-1630	SHORT COURSE (FULL-DAY) "Practical EMI/EMC Design and Modeling", Todd Hubing, University of Missouri-Rolla	Spanagel 101A
0900-1200	CONFERENCE REGISTRATION	Glasgow 103
0830-1200	SHORT COURSE (HALF-DAY) "Numerical Optimization in Electromagnetics: Genetic Algorithms", Randy L. Haupt, USAF Academy	Glasgow 109
1200-2000	CONFERENCE REGISTRATION	Glasgow 103

MONDAY EVENING

1900	PUBLICATIONS DINNER	Chef Lee's Mandarin House
------	----------------------------	---------------------------

TUESDAY MORNING 18 MARCH 1997

0700-0745	CONTINENTAL BREAKFAST	Glasgow Courtyard
0730	ACES BUSINESS MEETING President Hal Sabbagh	Glasgow 102
0745	WELCOME Eric Michielssen	Glasgow 102
SESSION 1:	VISUALIZATION (Parallel with Sessions 2, 3, & 4) Chair Janice L. Karty (Organizer)	Glasgow 102
0820	Visual Electromagnetics	E.K. Miller
0840	Computational/Analytical Diagnostic Tools for Electromagnetic Scattering	K.W. Horn & J. Shaeffer
0900	Interferometric 3D Imaging	C.A. Au
0920	Modern Graphics Applications for Visualization of Electromagnetic Radiation and Scattering	C.L. Yu
0940	MrPatches - Geometry Tool for Computational Electromagnetics (CEM)	D.D. Car & J.M. Roedder
1000	BREAK	
1020	Visualisation Issues for Time Domain Integral Equation Modelling	S.P. Walker & S.J. Dodson
1040	An Antenna Training Aid Using Electromagnetic Visualisation	A. Nott
1100	The XSignal Model-Based Validation Environment	D.P. Sullivan
1120	The Fieldinspector: A Graphic Field Representation System	P. Leuchtman & A. Witzig
1140	Data Compression Techniques for Antenna Pattern Storage and Retrieval	A. Nott
1200	LUNCH	

TUESDAY MORNING 18 MARCH 1997

SESSION 2: ADVANCED TIME-DOMAIN METHODS (Parallel with Sessions 1, 3, & 4)
Chair Steve Gedney (Organizer)

Ingersoll 122

0820	Solution of Boundary Value Problems in Time Domain Using Multiresolution Analysis	L.P.B. Katehi & J. Harvey
0840	High Resolution Algorithms for Computational Electromagnetics in the Time Domain	J.S. Shang
0900	FDTD M24 Dispersion and Stability in 3D	G. Haussmann & M. Picket-May
0920	Transparent Absorbing Boundary (TAB): Truncation of Computational Domains without Reflections	J. Peng & C.A. Balanis
0940	The Design of Maxwellian Smart Skins	R.W. Ziolkowski
1000	BREAK	
1020	Numerical Analysis of Photonic Band Gap Structures Using a Split-Update Time-Domain Algorithm	P.H. Harms, J.A. Roden, J.G. Maloney, M.P. Kesler, E.J. Kuster
1040	Modeling Dispersive Soil for FDTD Computation by Fitting Conductivity Parameters	C.M. Rappaport & S. Winton
1100	A Hybrid Analysis Using FDTD and FETD for Locally Arbitrary Shape Structures	D. Koh, H.B Lee, B. Houshmand, & T. Itoh
1120	The Time- and Space-Parallel FDTD Algorithm: Theory and Implementation	M.A. Jensen, Y. Rahmat-Samii, A. Fijany
1140	A Simple Distributed parallel Processing Method to Calculate Electrically Large Volumes with a Cartesian Coordinate Based Finite-Difference Time-Domain Technique	E.A. Baca, J.T. MacGillivray, D. Dietz, C.E. Davis, S.A. Blocher
1200	LUNCH	

SESSION 3: MODEL REDUCTION METHODS FOR COMPUTATIONAL ELECTROMAGNETICS
Chair Jin-Fa Lee (Organizer), Co-Chair Din-Kow Sun
(Parallel with Sessions 1, 2, & 4)

Engr Auditorium

0820	Computation of Transient Electromagnetic Wavefields in Inhomogeneous Media Using a Modified Lanczos Algorithm	R.F. Remis, P.M. van den Berg
0840	S-Parameters of Microwave Resonators Computed by Direct Frequency and Modal Frequency Finite Element Analysis	J. Brauer & A. Frenkel
0900	Reduced-Order Modeling of Electromagnetic Systems with Pade via Lanczos Approximations	A.C. Cangellaris & L. Zhao
0920	Alps: An Adaptive Lanczos-Pade Solution of Mixed-Potential Integral Equations	D.-K. Sun
0940	Application of AWE Method to the Spectral Responses of 3D TVFEM Modeling of Passive Microwave Devices	X. Zhang, J-F Lee, R. Dyczij-Edlinger
1000	BREAK	
1020	Solution of EM Problems Using Reduced Order Models by Complex Frequency Hopping	M.A. Kolbedhari, R. Achar, M. Nakhla, R. Achar, M. Srinivasan
1040	Transient Analysis via Electromagnetic Fast-Sweep Methods and Circuit Models	E. Bracken & Z. Cendes
1100	Integrating Data Obtained From Electromagnetic Field Analysis into Circuit Simulations	W.T. Beyene, J.E. Schutt-Aine

SESSION 4: COMPUTER SIMULATION OF ANTENNAS
Chair Jim Breakall, Co-Chair Boris Tomasic
(Parallel with Sessions 1, 2, & 3)

Ingersoll 361

0820	Application of Computational Electromagnetics to Shipboard HFDF System Simulation	J.B. Knorr
0840	Calculation of the Near Fields of a Large Complex Antenna Structure and Comparison with In Situ Measurements	C. Selcher, P. Elliot, E. Kennedy
0900	Simulation of the Contrawound Toroidal Helical Antenna	W.S. Ellithy, R.P.M. Craven, J.E. Smith
0920	Theoretical Studies on the Effect of Waveguide Geometry on the Radiating Slot	V.V.S. Prakash, N. Balakrishnan, S. Christopher
0940	Computed and Measured Radiation Patterns of Antennas with Aerodynamic Radomes	D.C. Jenn & S.M. Herzog
1000	BREAK	
1020	SAF Analysis Codes for Computing Shipboard Antenna Pattern Performance, Antenna Coupling, and RADHAZ	B.J. Cown & J.P. Estrada
1040	Far Field Patterns of Combined TE/TM Aperture Distributions	R.A. Speciale

TUESDAY MORNING 18 MARCH 1997**SESSION 4: COMPUTER SIMULATION OF ANTENNAS (cont)****Ingersoll 361**

- 1100 Calculation of Equivalent Generator Voltage and Generator Internal Impedance of Cylindrical Antennas in the Receiving Mode C.-C. Su
- 1120 Arrays of Sleeved Monopoles - Computer Codes B. Tomasic, E. Cohen, K. Sivaprasad
- 1140 A Hybrid-Method Synthesis of a Radiometric Antenna for Near-Field Sensing E. Di Giampaolo & F. Bardati
- 1200 LUNCH
- 1200 BOARD OF DIRECTORS MEETING/LUNCHEON Terrace Room, Herrmann Hall

TUESDAY AFTERNOON 18 MARCH 1997**SESSION 5: RADIATION PHYSICS (Parallel with Sessions 7, 8, & 9)
Chair Ed Miller (Organizer), Co-Chair Bob Bevensee****Glasgow 102**

- 1320 Some Observations Concerning Radiation Physics E.K. Miller
- 1340 Formulae for Total Energy and Time-Average Power Radiated from Charge-Current Distributions R.M. Bevensee
- 1400 An Overview of Antenna Radiation Basic Principles W.P. Wheless, Jr. & L.T. Wurtz

**SESSION 6: AMATEUR RADIO APPLICATIONS SESSION
Chair Perry Wheless (Organizer)**

- 1420 A Receiving Beverage Phased Array Antenna Design with Switchable Directions Based on NEC J.K. Breakall
- 1440 Advantages of Antenna Systems Using Skewed and Offset Directional Radiators W.P. Wheless, Jr.

**SESSION 7: COMPUTATIONAL METHODS FOR INVERSE SCATTERING
Chair Bill Weedon (Organizer), Co-Chair Gregory Newman
(Parallel with Sessions 5, 8, & 9)****Ingersoll 122**

- 1320 A Comparison of Linear and Non-Linear Conjugate Gradient Methods for Solving 3D Electromagnetic Inverse Problems G.A. Newman, D.L. Alumbaugh
- 1340 Application of Kaczmarz's Method to Nonlinear Inverse Scattering W.H. Weedon
- 1400 Statistical Characteristics of Reflection and Scattering of Electromagnetic Radar Pulses by Rough Surface and Buried Objects Y. Miyazaki, K. Takahashi, S. Knedlik
- 1420 Nondestructive Materials Measurement of Electrical Parameters with Readily Made Coaxial Probes T.R. Holzheimer, C.V. Smith, Jr.
- 1440 A Volume-Integral Code for Electromagnetic Nondestructive Evaluation R. Murphy, H.A. Sabbagh, A. Chan, & E.H. Sabbagh

**SESSION 8: WAVELETS AND FRACTALS (Parallel with Sessions 5, 7, & 9)
Chair Randy Haupt, Co-Chair Doug Werner (Co-Organizers)****Engr Auditorium**

- 1320 Target Identification Using Scattering Mechanism Modeling M.J. Walker, R.L. Haupt, J.L. Rasmussen
- 1340 Fast Array Factor Calculations for Fractal Planar Arrays R.L. Haupt & D.H. Werner
- 1400 NEC2 Modeling of Fractal-Element Antennas (FEA) N. Cohen
- 1420 Genetic Antenna Optimization with Fractal Chromosomes N. Cohen
- 1440 On the Use of Coifman Wavelets in Solving Scattering Problems M. Toupikov & G. Pan

**SESSION 9: FDTD AND FVTD I (Parallel with Sessions 5, 7, & 8)
Chair Melinda Picket-May****Ingersoll 361**

- 1320 A Fourth-Order, Time-Domain Algorithm for Maxwell's Equations J.L. Young, D. Gaitonde, J.S. Shang
- 1340 Improved Computational Efficiency by Using Sub-Regions in FDTD Simulations **STUDENT PAPER CONTEST** E.A. Jones & W.T. Joines
- 1400 FDTD Electromagnetic Code Validation Using IR Measurement Technique C. Reuter & M. Seifert
- 1420 An FDTD/FVTD 2D-Algorithm to Solve Maxwell's Equations for a Thinly Coated Cylinder J.S. Chen & K.S. Yee
- 1440 Study of Absorbing Boundary Conditions in the Context of the Hybrid Ray-FDTD Moving Window Solution Y. Pemper, E. Heyman, R. Kastner, R.W. Ziolkowski

TUESDAY AFTERNOON 18 MARCH 1997

INTERACTIVE TECHNICAL SESSION 10
1520 - 1740

VENDOR EXHIBITS
1300 - 1800

WINE AND CHEESE BUFFET
1630 - 1800

SESSION 10A: FDTD AND FVTD II

A Generalized Finite-Volume Time-Domain Algorithm for a Microwave Heating Problem on Arbitrary Irregular Grids

A Parallel FVTD Maxwell Solver Using 3D Unstructured Meshes

A Finite-Difference Spatial Compression Method for the Analysis of Bounded and Unbounded Striplines

Adapting an Algorithm of Computational Fluid Dynamics for Computational Electromagnetics

Application of a Finite-Volume Time-Domain Technique to Three-Dimensional Objects

Comparison of Equations for the FDTD Solution in Anisotropic and Dispersive Media

A Near-Field to Near-Field Transformation for Steady-State FDTD

SESSION 10B: INTEGRATED CIRCUITS AND PHOTONICS

Transient Simulation of Breakdown Characteristics of a Miniaturized MOSFET based on a Non-isothermal Non-Equilibrium Transport Model

Numerical Simulation of Electro-thermal Characteristics in Semiconductor Devices Taking Account of Chip Self-heating and In-chip Thermal Interdependence

A Simple Computational Electromagnetic Analysis Example of Electromagnetic Coupling to Pyro Circuits

Applications of Photonic Band Gap Materials

New Method for the Numerical Modelling of the Quasi-Optical Systems

SESSION 10C: SIGNAL PROCESSING TECHNIQUES FOR CEM

A Digital Filter Technique for Electromagnetic Modelling of Conducting Composite Materials

Investigating the Use of Model-Based Parameter Estimation for Electromagnetic-Data Phase Recovery

Real Time Adaptive Forward Error Correction Scheme

A Novel Spatial Modulation Spread-Spectrum Technique

Application of Nonlinear Time Series Analysis to the Measurements of Not Perturbed Ionosphere

The Technology of Signal and Data Processing in Modern Digital Ionosonde

Time Frequency and Time Scale Analysis for Electromagnetics (Spectrograms, Wavelets, and More)

SESSION 10D: ANTENNA APPLICATIONS

Synthesis of Circular Polarized Normal Mode Helical Antenna

Crossed Square Loop Antenna

An Experimental Investigation of the Proposed Crossed Field Antenna

Performance Analysis of Zigzag Antenna for Portable Radio Equipment

Antenna Array Factors for Dipole Antennas Above an Imperfectly Conducting Half-Space

Ballroom, Herrmann Hall

Ballroom, Herrmann Hall

Ballroom, Herrmann Hall

Ballroom, Herrmann Hall

H. Zhao & I. Turner

J. P. Cioni, L. Fezoui,
F. Poupaud

O.J. Sucre Rosales, D. Suster

T.E. Hodgetts & C.C. Lytton

F.G. Harmon & A.J. Terzuoli

G.J. Burke & D.J. Steich

K.A. Lysiak & D.H. Werner

Ballroom, Herrmann Hall

W.-C. Choi, H. Kawashima,
R. Dang

H. Kawashima, C. Moglestue,
M. Schlechtweg & R. Dang

R. Perez

M.M. Sigalas, R. Biswas,
Q. Li, K.-M. Ho, C.M. Soulloulis,
D.D. Crouch

A.I. Kleev

Ballroom, Herrmann Hall

J.A. Cole, J.F. Dawson,
S.J. Porter

E.K. Miller

S. Veluswamy

S.A. Pradels, N. Marshall,
N. Aery, O.R. Baiocchi

A.L. Karpenko
N.I. Manaenkova

A.L. Karpenko, & V.V. Koltsoy

C.J. McCormack

Ballroom, Herrmann Hall

S.H. Zainud-Deen,
H.A. Sharshar, K.H. Awadalla

A.A. Sharshar,
S.H. Zainud-Deen,
S.M.El-Halafawy

M.N.I. Fahmy, A.M. Bahnacy,
S.H. Zainud-Deen,
K.H. Awadalla

S.H. Zainud-Deen,
K.H. Awadalla, A.I. Bahnacy,
H.A. Sharshar

J.W. Williams

TUESDAY AFTERNOON 18 MARCH 1997

SESSION 10D: ANTENNA APPLICATIONS (cont)

Energy Transfer from Free Space Transient Waveforms Through HF Antennas to Arbitrary Loads

Ballroom, Herrmann Hall

M.J. Packer

A 12 Beam Cylindrical Array Antenna for AMPS and PCS Applications

G. Martek & T. Elson

SESSION 10E: SCATTERING AND DIFFRACTION

Wave Scattering on a Body in Layered Medium

A.G. Kyurkchan
S.A. Manenkov

Double Variational Method in a Diffraction Problem of Waves on Lattices

A.G. Kyurkchan & A.I. Sukov

Algorithm for Prediction of Scattering from Thin Cylindrical Conductors Using Field Decomposition

P.K. Bishop, J.R. James,
R.T. Biggs

New Method of the Decision of a Diffraction Problem of Waves on a Impedance Body

A.I. Kleev, A.G. Kyurkchan
A.I. Sukov

Numerically Exact Algorithm for the H and E-Wave Scattering from a Resistive Flat-Strip Periodic Grating

T. Zinenko, A.I. Nosich,
Y.Okuno, & A. Matsushima

The Method of Definition of Radar Cross-Section of Ships in the Quasioptical Area of Electromagnetic Waves Radio Range

T. Petrenko & T. Shiyko

SESSION 10F: NUMERICAL METHODS

Ballroom, Herrmann Hall

Numerical Convergence and Richardson Extrapolation

R.C. Booton, Jr.

Powerful Recursive Algorithm for the Exhaustive Resolution of a Nonlinear Eigenvalue Problem

Ph. Riondet, D. Bajon,
H. Baudrand

A Dense Out-of-Core Solver for Workstation Environments

C.E. Lee & R.M. Zazworsky

Mathematical Representation of Multiport Resonator Test Data

R.A. Speciale

SESSION 10G: SIMULATION

Ballroom, Herrmann Hall

A Comparison of Analytical and Numerical Solutions for Induction in a Sphere with Equatorially Varying Conductivity by Low-Frequency Uniform Magnetic Fields of Arbitrary Orientation

T.W. Dawson & M.A. Stuchly

Modeling of Laminated Cores by Homogeneous Anisotropic Cores for Magnetics Simulation

J.E. Kiwitt, A. Dietermann,
K. Reib

Barring Characteristic of an Ion Shutter

B.M. Cramer & D.A. Mlynski

Combined Electromagnetic and Particle Simulations of High-Power RF Windows for Tritium Production Accelerators

S. Humphries & D. Rees

Stability Analysis of Re-Entrant Multi-Turn Toroidal/Helical Electron Orbits in Strong-Focusing Alternating-Gradient

R.A. Speciale

1830 **NO HOST BAR**

Ballroom, Herrmann Hall

1930 **AWARDS BANQUET**

Ballroom, Herrmann Hall

WEDNESDAY MORNING 19 MARCH 1997

0700-0745 **CONTINENTAL BREAKFAST**

Glasgow Courtyard

SESSION 11: FINITE ELEMENT ANALYSIS (Parallel with Sessions 12, 13, & 14)
Chair John Brauer (Organizer), Co-Chair John DeFord

Glasgow 102

0820 Finite-Element and Method-Of-Moments Analyses of an Ultra-wide Bandwidth TEM Horn

M.H. Vogel

0840 A Modified Mei Method for Solving Scattering Problems with the Finite Element Method

Y. Li & Z. Cendes

0900 Investigation of the Limitations of Perfectly-Matched Absorber Boundaries in Antenna Applications

J.F. DeFord

0920 Finite-Element Modeling of Magnetic Resonance Image Formation in Complex Geometries

J.G. Harrison & J.T. Vaughan

0940 Finite Elements for Microwave Heating Considering the Coupling of Electromagnetic Fields and Heat Transfer

H. Zhang, A.K. Datta,
J.R. Brauer

1000 **BREAK**

1020 A Generalized Method for Including Two Port Networks in Microwave Circuits Using the Finite Element Method

E. Yasan & L.P.B. Katehi

1040 Projecting Between Complementary Vector Basis Functions **STUDENT PAPER CONTEST**

J. Scott Savage
A.F. Peterson

WEDNESDAY MORNING 19 MARCH 1997

SESSION 11: FINITE ELEMENT ANALYSIS (cont)

Glasgow 102

- 1100 Duality Between Finite Elements and Hodge Operator in Three Dimensions
1120 MNA and FEM Methods Used for Analysis of High-Speed Interconnections

A. de La Bourdonnaye & S. Lala
M.A. Kolbehdari, M.N.O. Sadiku

SESSION 12: ADVANCES IN TRANSMISSION LINE MATRIX (TLM) MODELING I
Chair Wolfgang Hoefer (Organizer), Co-Chair Fred German
(Parallel with Sessions 11, 13, & 14)

Ingersoll 122

- 0820 Improved Modelling of Ferrite Tiles as Frequency Dependent Boundaries in General Time-Domain TLM Schemes
0840 The Use of Sources for TLM Modeling of Complex Materials
0900 Analysis of Planar Structure on General Anisotropic Material by Unified Frequency- and Time-Domain TLM Method
0920 Towards a TLM Description of an Open-Boundary Condition
0940 A Modified 3D-TLM Variable Node for the Berenger's Perfectly Matched Layer Implementation
1000 **BREAK**
1020 Effects of the Boundary Conditions in Inverse TLM Studies
1040 Electromagnetic Field Computations by a Generalized Network Formulation
1100 A Comparative Study of Dispersion Errors and Performance of Absorbing Boundaries in SCN-TLM and FDTD
1120 Electromagnetic Fields Generated by Current Transients on Protection Structures Using TLM - A FD-TD Comparison

V. Trenkic, J. P. I. Argyri,
C. Christopoulos
J. Represa, A.C.L. Cabeceira,
I. Barba
Q. Zhang, J. Huang, & K. Wu
D. de Cogan & Z. Chen
J.L. Dubard & D. Pompei
S. Barraud, J.L. Dubard,
D. Pompei
L.B. Felsen, M. Mongiardo,
P. Russer
L. De Menezes, C. Eswarappa,
W.J.R. Hoefer
G.P. Caixeta & J.P. Pissolato

SESSION 13: HYBRID TECHNIQUES FOR LARGE BODY PROBLEMS
Chair Donald Pflug, Co-Chair Dr. Burkholder (Co-Organizers)
(Parallel with Sessions 11, 12, & 14)

Engr Auditorium

- 0820 Hybrid MoM/SBR Method to Compute Scattering from a Slot Array Antenna in a Complex Geometry
0840 Use of Near-Field Predictions in the Hybrid Approach
0900 A Hybrid Surface Integral Equation and Partial Differential Equation Method
0920 Faster Hybrid Finite Element-Integral Equation Methods
0940 An Efficient Iterative Procedure Combining High-Frequency and Numerical Methods for Solving Electrically Large Antenna and Scattering Problems
1000 **BREAK**
1020 Duct RCS Computation Using a Hybrid Finite Element Integral Equation Approach
1040 Validation Studies of the GEMACS Computational Electromagnetics Code Using Measurement Data From the Transformable Scale Aircraft-Like Model (TSAM)
1100 A Combination of Current- and Ray-Based Techniques for the Efficient Analysis of Electrically Large Scattering Problems
1120 Field Computation for Large Dielectric Bodies by the PPP Method
1140 A Hybrid Approach for Simulation of Log Periodic Antennas on an Aircraft
1200 **LUNCH**

A.D. Greenwood & J. Jin
J.L. Karty, J.M. Putnam,
J.M. Roedder, & L. Yu
J. Putnam & M. Axe
S. Bindiganavale, J. Gong,
Y. Erdemli, & J. Volakis
R.J. Burkholder, P.H. Pathak,
R. Lee, & D.H. Kwon
Y.C. Ma, R. McClary,
M. Sancer, & G. Antilla
D.R. Pflug & T.W. Blocher
U. Jakobus & F.M. Landstorfer
M.S. Abrishamian,
N.J. McEwan,
R.A. Sadeghzadeh
B.E. Gray & J.J. Kim

SESSION 14: COMPOSITE MATERIALS (Parallel with Sessions 11, 12, & 13)
Chair Keith Whites (Organizer), Co-Chair Rodolfo E. Diaz

Glasgow 109

- 0820 Application of the Analytic Theory of Materials to the Modeling of Composites in Electromagnetic Engineering
0840 Computational Percolation Theory and Experimental Results for the Wide-band Dispersive Behavior of a Rubber-Iron Composite
0900 Diaz-Fitzgerald Time Domain Method Applied to Electric and Magnetic Debye Material

R.E. Diaz
W.M. Merrill, M.C. Squires,
N.G. Alexopoulos
F. De Flaviis, M. Noro,
R. E. Diaz, & N.G. Alexopoulos

WEDNESDAY MORNING 19 MARCH 1997

SESSION 14: COMPOSITE MATERIALS (cont)

Glasgow 109

- | | | |
|------|----------------------------------------------------------------------------------------------------------------------------------------------------------------------------------------------|-----------------------------------------------------------------------------------------|
| 0920 | Aspects of Numerical Multipole Modelling of Bianisotropic Composite Materials Using the Method of Counterpropagating Waves | L.R. Arnaut |
| 0940 | Experimental Confirmation of a Numerical Constitutive Parameters Extraction Methodology for Uniaxial Bianisotropic Chiral Materials | K.W. Whites & C.Y. Chung |
| 1000 | BREAK | |
| 1020 | A Frequency Domain Dispersion and Absorption Model for Numerically Extracting the Constitutive Parameters of an Isotropic Chiral Slab from Measured Reflection and Transmission Coefficients | M. Bingle, I.P. Theron
J.H. Cloete |
| 1040 | Scattering from Inhomogeneous Chiral Cylindrical Composites Using Axial Beltrami Fields and the Fast Multipole Method | B. Shanker, E. Michielssen,
W.C. Chew |
| 1100 | The Method of Auxiliary Sources in Computational Electrodynamics | D. Karkashadze, R. Zaridze,
R. Jobava, F. Bogdanov,
P. Shubitidze, & G. Bit-Babik |

WEDNESDAY AFTERNOON 18 MARCH 1997

SESSION 15: NEC AND COMPUTER CODES FOR COMPUTATIONAL ELECTROMAGNETICS
Chair Pat Foster, Co-Chair Richard Adler
(Parallel with Sessions 16, 17, 18, & 19)

Glasgow 102

- | | | |
|------|------------------------------------------------------------------------------------------------------------------|------------------------------------------------------|
| 1320 | IONEC: Mesh Generation and Data Entry for NEC | S.P. Walker |
| 1340 | Experiments with NEC3 and NEC4 - Simulation of Helicopter HF Antennas | S.J. Kubina, C.W. Trueman,
D. Gaudine |
| 1400 | Building Models for NEC2 and NEC-BSC | U. Lidvall |
| 1420 | Modeling AM and FM Antennas on Automotive Vehicles Using NEC | N. DeMinco |
| 1440 | Simulation of Portable UHF Antennas in the Presence of Certain Dielectric Structures Using the NEC-2 Code | R.J. DeGroot, A.A. Efanov,
Krenz, & J.P. Phillips |
| 1500 | BREAK | |
| 1520 | Scattmat: A Mode Matching and Generalized Scattering Matrix Code for Personal Computers in a Windows Environment | A. Liberal, C. del Rio,
R. Gonzalo, & M. Sorolla |
| 1540 | An Evaluation of Software Packages Based on Moment Methods for TV Antenna Design | I.F. Anitzine
C. Jaureguibeitia |
| 1600 | FASANT: Fast Computer Code for the Analysis of Antennas on Board Complex Structures | M.P. Catedra & J. Perez |
| 1620 | FASPRO: Fast Computer Tool for the Analysis of Propagation in Personal Communication Network | M.F. Catedra & J. Perez |
| 1640 | Evaluation of Near Field Electromagnetic Scattering Codes for Airborne Application | J.M. Taylor, Jr., & A.J. Terzuoli |
| 1700 | Recent Enhancements to ALDAS V3.00 | P.R. Foster |

SESSION 16: PML: THEORETICAL AND NUMERICAL IMPLEMENTATION ISSUES
Chair Andreas Cangellaris, Co-Chair Peter Petropoulos (Co-Organizers)
(Parallel with Sessions 15, 17, 18, & 19)

Ingersoll 122

- | | | |
|------|--------------------------------------------------------------------------------------------|-------------------------------------------------|
| 1320 | On the Construction of Perfectly Matched Layers | S. Abarbanel & D. Gottlieb |
| 1340 | The Application of PML ABCs for High-Order FD-TD Schemes | P.G. Petropoulos |
| 1400 | Efficient Implementation of the Uniaxial PML Absorbing Media for Generalized FDTD Methods | S.D. Gedney |
| 1420 | Generalization of PML to Cylindrical Geometries | J. Maloney & M. Kesler |
| 1440 | PML Study of FEM Modeling of Antennas and Microwave Circuits | Y. Botros, J. Gong,
J.L. Volakis |
| 1500 | BREAK | |
| 1520 | Using PML in 3D FEM Formulations for Electromagnetic Field Problems | J.-F. Lee, R. Dyczij-Edlinger,
G. Peng |
| 1540 | The Design of Maxwellian Absorbing Materials for Numerical Absorbing Boundary Conditions | R.W. Ziolkowski |
| 1600 | A New Artificial Medium Using Unsplit Anisotropic PML for Mesh Truncation in FDTD Analysis | Y. Chen, M.-s Tong,
M. Kuzuoglu, & R. Mittra |
| 1620 | On the Use of PML ABC's in Spectral Time-Domain Simulations of Electromagnetic Scattering | B. Yang, D. Gottlieb,
J.S. Hesthaven |

WEDNESDAY AFTERNOON 18 MARCH 1997

SESSION 16: PML: THEORETICAL AND NUMERICAL IMPLEMENTATION ISSUES (cont)

Ingersoll 122

- 1640 FVTD Schemes Using Conformal Hybrid Meshes and a PML Medium Technique
F. Bonnet, J.P. Cioni, L. Fezoui, & F. Poupaud
- 1700 PML-FDTD Simulation for Dispersive, Inhomogeneous, and Conductive Media
W.C. Chew, M. Oristaglio, T. Wang

SESSION 17: FAST SOLVERS FOR ELECTROMAGNETIC SCATTERING PROBLEMS
Chair Eric Michielssen (Organizer), Co-Chair Weng Chew
(Parallel with Sessions 15, 16, 18, & 19)

Engr Auditorium

- 1320 A Fast Scheme for Electromagnetic Characterization of Inhomogeneous Domains
M.A. Jensen & J.D. Freeze
- 1340 Scattering of Electromagnetic Waves in Large-Scale Rough Surface Problems Based on the Sparse-Matrix Canonical-Grid Method
K. Pak, L. Tsang, C. Chan, J. Johnson, & Q. Li
- 1400 Comparison of Two Fast Integral Equation Algorithms for Scattering
S. Bindiganavale, H. Anastassiou, & J. Volakis
- 1420 The Spectral Lanczos Decomposition Method for Solving Low-Frequency Electromagnetic Diffusion by the Finite Elements Method
M. Zunoubi, J. Jin, W.C. Chew
- 1440 A Hybrid Fast Steepest Descent - Multipole Algorithm for Analyzing 3-D Scattering from Rough Surfaces
V. Jandhyala, E. Michielssen, W.C. Chew
- 1500 **BREAK**
- 1520 Wavelet Packet Methods for Computational Electromagnetic Scattering
W. Golik, G. Welland, D.S. Wang
- 1540 Matrix Assembly in MOM/FMM Codes
E. Yip & Benjamin Dembart
- 1600 A Near-Resonance Decoupling Approach (NRDA) for Scattering Solution of Objects with Cavities
C.C. Lu & W.C. Chew
- 1620 Solution of Maxwell Equations Using Krylov Subspace from Inverse Powers of Stiffness Matrix
V. Druskin, L. Knizhnerman, P. Lee
- 1640 Efficient Computation of Integral Operators for Axisymmetric Geometries
A. Berthon
- 1700 Fast Illinois Solver Code (FISC)
J.M. Song, C.C. Lu, W.C. Chew, & S.W. Lee

SESSION 18: WAVE PROPAGATION (Parallel with Sessions 15, 16, 17, & 19)
Chair Bill Weedon

Ingersoll 361

- 1320 Wave Propagation on Two Dimensional Slow-Wave Structures with Square Lattice
R.A. Speciale
- 1340 Wave Propagation on Two Dimensional Slow-Wave Structures with Hexagonal Lattice
R.A. Speciale
- 1400 Wave Propagation on Two-Level Twin-Stacked-Honeycomb Structures
R.A. Speciale
- 1420 Adiabatic Modes of Curved EM Waveguides of Arbitrary Cross Section
V.A. Baranov & A.V. Popov
- 1440 Nontraditional Waveguiding Systems
Y.N. Cherkashin
V.A. Eremenko
- 1500 **BREAK**
- 1520 Ground Conductivity Evaluation Method based on Measurements of Radio Wave Path Loss
I. P. Zolotarev, V.A. Popov, V.P. Romanuk
- 1540 Two-Scale Asymptotic Description of Radar Pulse Propagation in Lossy Subsurface Medium **STUDENT PAPER CONTEST**
V.A. Vinogradov, V.A. Baranov
A.V. Popov
- 1600 Decomposition Method for Nonlinear Problem of EM Wave Propagation
V.A. Eremenko
- 1620 Modeling of Electromagnetic Low Frequency Scattering Smooth 3D Bodies in Water
J. Mattsson

SESSION 19: EMI/EMC (Parallel with Sessions 15, 16, 17, & 18)
Chair Todd Hubing (Organizer), and Co-Chair Jim Drowniak

Spanagel 117

- 1320 Modeling of EMI Emissions from Microstrip Structures with Imperfect Reference Planes
B. Archambeault
- 1340 Modeling of Non-Standard Ground Plane Configurations for EMI Open Area Test Sites
B. Archambeault
- 1400 Reducing EMI Through Shielding Enclosure Perforations Employing Lossy Material: FDTD Modeling and Experiments
M. Li, S. Radu, Y. Ji, W. Cui, J.L. Drowniak, T.H. Hubing, T.P. VanDoren
- 1420 Low Frequency Magnetic Fields of Power Lines
H.A. Kalhor
- 1440 Coupling into Non-Rectangular Cavities: Simulation and Experiments
J.L. Drowniak, T.H. Hubing, J.v. Hagen, D. Lecoite, J.-L. Lasserre & W. Tabbara

WEDNESDAY AFTERNOON 18 MARCH 1997

SESSION 19: EMI/EMC (cont)

Spanagel 117

1500 **BREAK**

1520 Transient Electrodynamics of Electrostatic Discharge

R. Jobava, D. Karkashadze,
D. Pommerenke, P. Shubitidze,
R. Zaridze, & M. Aidam

1540 Statistical Description of Cable Current Response Inside a Leaky Enclosure

R. Holland & R. St. John

THURSDAY MORNING 20 MARCH 1997

0700-0745 **CONTINENTAL BREAKFAST**

Glasgow Courtyard

SESSION 20: CEM ANALYSIS: THE APPROACH OF THE FUTURE
Chair Kenneth Siarkiewicz (Organizer), Co-Chair Andrew Drozd
(Parallel with Sessions 21, 22, & 23)

Glasgow 102

0820 Application of the Research and Engineering Framework (REF) to Antenna Design at Raytheon

B. Hantman, J. LaBelle,
Y. Chang, K. Siarkiewicz,
R. Abrams

0840 Research and Engineering Framework (REF) Database and CEM Code Integration Using GEMACS 5.3

J.A. Evans

0900 Computational Electromagnetics' Future Database Architecture

G.T. Capraro & K. Siarkiewicz

0920 An Expert System Tool to Aid CEM Model Generation

A. L.S. Drozd, T.W. Blocher,
K.R. Siarkiewicz

0940 Web-Based High Performance Computational Electromagnetics Servers

D.M. Leskiw, G.S. Ingersoll,
T.J. Vidoni, G.C. Fox, K. Dincer

1000 **BREAK**

1020 Graphical User Interface for Computational Electromagnetic Software

B. Joseph

1040 An Algorithm for Solving Coupled Thermal and Electromagnetic Problems

H. Sabbagh, L.W. Woo, X. Yang

1100 Apatch Applied

T.W. Blocher

SESSION 21: FDTD APPLICATIONS (Parallel with Sessions 20, 22, & 23)
Chair John H. Beggs (Organizer), Co-Chair Sydney Blocher

Ingersoll 102

0820 Implementation of a Two Dimensional Plane Wave FDTD Using One Dimensional FDTDs on the Lattice Edges

S.C. Winton & C.M. Rappaport

0840 FDTD Analysis for Solar Cell Design

T. Marshall & M. Piket-May

0900 Clock Design and Analysis for a Superconductive Crossbar Switch

P. Vichot, M. Piket-May, J. Mix,
Z. Schoenborn, & J. Dunn

0920 Computational Evaluation of an Optical Sensor Using the FDTD Method

R.R. DeLyser

0940 Computation of Crosstalk on Printed Circuit Board Using FDTD Method

G.C. Miranda & J.O.S. Paulino

1000 **BREAK**

1020 Application of FD-TD Methods to Planetary and Geological Remote Surface Sensing

J.E. Baron, G.L. Tyler,
R.A. Simpson

1040 Incorporation of Active Devices Using Digital Networks in FDTD Method

C.-N. Kuo & T. Itoh

1100 FDTD Calculations of Energy Absorption in an Anatomically Realistic Model of the Human Body

P.J. Dimbylow

1120 An Analysis of New and Existing FDTD Methods for Isotropic Cold Plasma and a Method for Improving Their Accuracy

S.A. Cummer

1140 Applications of the Hybrid Dynamic-Static Finite Difference Approach on 3D-MMIC Structures

S. Lindenmeier, P. Russer
W. Heinrich

1200 **LUNCH**

SESSION 22: PLANAR ANTENNAS AND CIRCUITS (Parallel with Sessions 20, 21, & 23)
Chair Guy Vandenbosch (Organizer), Co-Chair Niels Fache

Engr. Auditorium

0820 Planar Antennas: Overview of the Modeling Efforts in Europe

G.A.E. Vandenbosch

0840 Microstrip Patch Antenna Research Activities at the Technical University of Lisbon

C. Peixeiro

0900 A Full-Wave Electromagnetic Simulation Technology for the Analysis of Planar Circuits

N. Fache

0920 Analysis of Metal Strips and Corrugations Inside Cylindrical Multilayer Structures by Using G1DMULT

Z. Sipus, P.S. Kildal,
S. Raffaelli

THURSDAY MORNING 20 MARCH 1997

SESSION 22: PLANAR ANTENNAS AND CIRCUITS (cont)

Engr. Auditorium

- 0940 G1DMULT -- A Numerical Algorithm for Computing Green's Functions of Multilayer Objects
- 1000 **BREAK**
- 1020 Fast Moment Method Algorithm for Electromagnetic Scattering by Finite Strip Array on Dielectric Slab
- 1040 Optimization of Various Printed Antennas Using Genetic Algorithm: Applications and Examples
- 1100 Characterization of Asymmetric Microstrip Transmission Lines on Multilayers with FR-4 Composite Overlay

P.-S. Kildal, M. Johansson,
Z. Sipus

B. Popovski, B. Spasenovski,
J. Bartolic

M. Hindi & J.P. Daniel

M. El-Shenawee & H.Y. Lee

SESSION 23: SCATTERING (Parallel with Sessions 20, 21, & 22)
Chair Jianming Jin, Co-Chair Atef Elsherbeni

Glasgow 109

- 0820 RCS and Antenna Modeling with MOM Using Hybrid Meshes
- 0840 Application of Moment Method Solutions to RCS Measurement Error Mitigation
- 0900 Scattering from Arbitrarily Shaped Cylindrical Objects Characteristic Modes
- 0920 A High Order Solver for Problems of Scattering by Heterogeneous Bodies
- 0940 Fictitious Domain Method for Calculating the Radar Cross Section
- 1000 **BREAK**
- 1020 Electromagnetic Scattering from Eccentric Cylinders at Oblique Incidence
- 1040 EM Scattering from Periodic Gratings of Lossy Conductors
- 1100 A New Approach for Solving Scattering Problems in Stratified Conductive Media in Time Domain
- 1120 Elimination of Backscattering from Conducting Surfaces Using Externally Loaded Straight Wire System
- 1140 Iterative Technique for Scattering and Propagation Over Arbitrary Environments

J. M. Putnam & J. D. Kotulski

J. Stach

G. Amendola, G. Angiulli,
G. Di Massa

O.P. Bruno & A. Sei

F. Millot & F. Collino

H.A. Yousif & A.Z. Elsherbeni

H.A. Kalhor

M. Weber & K. Reiss

S.H. Zainud-Deen

O.M. Conde & M.F. Catedra

THURSDAY AFTERNOON 20 MARCH 1997

SESSION 24: OPTIMIZATION TECHNIQUES FOR ELECTROMAGNETICS
Chair John Volakis (Organizer), Co-Chair Eric Michielssen
(Parallel with Sessions 25 & 26)

Glasgow 102

- 1320 Array Pattern Nulling in the Complex Plane Optimised by a Genetic Algorithm
- 1340 Automated Electromagnetic Optimization of Microwave Circuits
- 1400 Design Optimization of Patch Antennas Using the Sequential Quadratic Programming Method
- 1420 A Novel Integration of Genetic Algorithms and Method of Moments (GA/MoM) for Antenna Design
- 1440 Using the Gene Expression Messy Genetic Algorithm for Electromagnetic System Design
- 1500 **BREAK**
- 1520 Continuous Parameter vs. Binary Genetic Algorithms
- 1540 Optimisation of Wire Antennas with Genetic Algorithms and Simulated Annealing
- 1600 Design, Analysis and Optimisation of Quadrifilar Helix Antennas on the European Met Op Space Craft

R.J. Mitchell, B. Chambers,
A.P. Anderson

J.W. Bandler, R.M. Biernacki,
S.H. Chen

Z. Li, P. Paspalambros,
J. Volakis

J. M. Johnson
Y. Rahmat-Samii

D. Treyer, D.S. Weile,
E. Michielssen, & D.E. Goldberg

R.L. Haupt

B. Kemp, S.J. Porter,
J.F. Dawson

G.A.J. van Dooren & R. Cahill

SESSION 25: ADVANCES IN TRANSMISSION LINE MATRIX (TLM) MODELING II
Chair Wolfgang J.R. Hoefer (Organizer), Co-Chair Peter Russer
(Parallel with Sessions 24 & 26)

Ingersoll 122

- 1320 Characteristics of the Optimization Problem for Analysis of Time Series Obtained from TLM or 2D-FDTD Homogeneous Waveguide Simulations
- 1340 Comparison of 3D TLM Meshing Techniques for Modeling Microwave Components
- 1400 A Comparison of Commercially Available Transmission Lines Modeling (TLM) and Finite Element Method (FEM) 3-D Field Solvers

U. Mueller, M.M. Rodriguez,
M. Walter, & A. Beyer

J.L. Herring & W.J.R. Hoefer

F.J. German & J.A. Svigelj

THURSDAY AFTERNOON 20 MARCH 1997

SESSION 25: ADVANCES IN TRANSMISSION LINE MATRIX (TLM) MODELING II (cont)

Ingersoll 122

- | | | |
|------|---------------------------------------------------------------------------------------------------------------------------------------------------------------------|-----------------------------------------------------------------------------------------------|
| 1420 | Validation of Transmission Line Matrix, Finite-Integration Technique, and Finite-Difference Time-Domain Simulations of a Multi-Segment Dielectric Resonator Antenna | N.R.S. Simons, A. Petosa, M. Cuhaci, A. Ittipiboon, R. Siushansian, J.Lo Vetri, S. Gutschling |
| 1440 | Microstrip Antenna Characterization Using TLM and Berenger's Perfectly Matched Layers (PML) | J.L. Dubard & D. Pompei |
| 1500 | BREAK | |
| 1520 | Parallelization of a 3D-TLM-Algorithm on a Workstation Cluster | C. Fuchs, P. Fischer, A.J. Schwab |
| 1540 | A Comparison of the TLM and Finite-Difference Excitation Schemes for the Diffusion- and Wave-Equations | C. Kenny, R. Harvey, D. de Cogan |
| 1600 | Drift-Diffusion Using Transmission Line Matrix Modelling | A. Chakrabarti & D. de Cogan |
| 1620 | Full Wave Characteristics of a Two Conductor Multilayer Microstrip Transmission Line Using the Method of Lines | M. El-Shenawee, A.Z. Elsherbeni |
| 1640 | Sources of Error within Lattice Gas Automata Simulation of Electromagnetic Field Problems | N. Simons, G. Bridges, D. Cule, M. Zhang, & M. Cuhaci |

SESSION 26: PLANAR AND CONFORMAL ANTENNAS AND CIRCUITS)

Engr Auditorium

Chair Giuseppe Vecchi (Organizer)
(Parallel with Sessions 24 & 25)

- | | | |
|------|-----------------------------------------------------------------------------------------------------------------------|--------------------------------------------------------|
| 1320 | Analysis and Synthesis of Conformal Microstrip Antennas with a Fast and Accurate Algorithm Using New Symbolic Objects | J.-P Damiano, J.-M. Ribero, M. Scotto, & P. Pirinoli |
| 1340 | Computationally Efficient MoM and Its Applications | L. Alatan, M.I. Aksun, K. Leblebicioglu, & M.T. Birand |
| 1400 | Analysis of Arrays of Elements over Surfaces which can be Conformed to a Body of Revolution | S. Piedra, J. Basterrechea, M.F. Catedra |
| 1420 | Space/Time Adaptive Meshing Using the Multiresolution Time Domain Method (MRTD) | E.I Tentzeris, A. Cangellaris, L.P.B. Katehi |
| 1440 | Static Extraction, "Static" Basis Functions and Regularization in the Analysis of Printed Antennas | G. Vecchi, P. Pirinoli, L. Matekovits, & M. Orefice |
| 1500 | BREAK | |
| 1520 | Transmission Line Approach for the Study of Planar Periodic Structures | R. Orta, P. Savi, R. Tascone, R. Zich |
| 1540 | Wavelet-Based Modeling of Wired Antennas and Scatterers | K.F. Sabet & L.P.B. Katehi |
| 1600 | Computational Aspects of Finite and Curved Frequency Selective Surfaces | J. Vardaxoglou |

FRIDAY MORNING 21 MARCH 1997

- | | | |
|-----------|--------------------------------------------------------------------------------------------------------------------------------------------------------------------------------------|-------------------------|
| 0830-1630 | SHORT COURSE (FULL-DAY)
"Finite Difference Time Domain Modeling and Applications"
Stephen Gedney, University of Kentucky and James Maloney, Georgia Tech Res. Institute | Glasgow 102 |
| 0830-1630 | SHORT COURSE (FULL-DAY)
"Introduction to Radar via Physical Wavelets", Gerald Kaiser, U Mass-Lowell | Ingersoll 122 |
| 0830-1630 | SHORT COURSE (FULL-DAY)
"Mathematical Software for Computational Electromagnetics", Jovan Lebaric, Naval Postgraduate School | Spanagel 419 |
| 0830-1200 | SHORT COURSE (HALF-DAY)
"Radiation Physics", Edmund K. Miller | Engr. Auditorium |

FRIDAY AFTERNOON

- | | | |
|-----------|-------------------------------------------------------------------------------------------------------------------------------------------------|-------------------------|
| 1300-1630 | SHORT COURSE (HALF-DAY)
"Introduction to FEKO: A Hybrid Method of Moments/Physical Optics (MoM/PO) Code"
J.F.C. Meyer, EM Software | Engr. Auditorium |
|-----------|-------------------------------------------------------------------------------------------------------------------------------------------------|-------------------------|

SHORT COURSE INFORMATION

THE 13TH ANNUAL REVIEW OF PROGRESS IN APPLIED COMPUTATIONAL ELECTROMAGNETICS

GENERAL INFORMATION

The Applied Computational Electromagnetics Society (ACES) is pleased to announce ten short courses to be offered with its annual meeting on March 17-21, 1997. The short courses will be held on Monday, March 17, and Friday, March 21. Short courses registration begins at 7:30 AM on Monday, March 17. **PREREGISTRATION BY MAIL IS SUGGESTED!** Note: Tuesday through Friday will be technical sessions **and vendor exhibits!!!!** ACES has the right to cancel a course at any time with full refund. For further information contact Keith Whites, Short Course Chairman: University of Kentucky, Dept. of Electrical Engineering, 453 Anderson Hall, Lexington, KY 40506-0046, Phone 606-257-1768, FAX 606-257-3092, Email:whites@engr.uky.edu. The fee will be \$90 for a half-day short course and \$140 for a full-day course, if booked before Friday, February 28, 1997. **NOTE: Short Course attendance is NOT covered by the Symposium Registration Fee! Short courses can be taken without attendance at symposium.**

COURSE DESCRIPTIONS

1. **"Finite Elements for Electromagnetics,"** by Dr. John Brauer and Dr. Zoltan Cendes, Ansoft Corp. (Full-day course, Monday, March 17) **(note! optional book available for \$50.00)**

This course will develop and apply two-dimensional and three-dimensional finite elements, both edge-based and nodal-based. Local and global mesh truncation techniques, including the perfectly matched absorber method, will be examined. Applications will include antennas, scattering, microwave components, nonlinear magnetic apparatus, electronic packaging, and electromagnetic compatibility. An optional book, "What Every Engineer Should Know About Finite Element Analysis", published by Marcel Dekker in 1993, will be furnished to those attendees who wish to purchase it for \$50.

2. **"Ray-Tracing Techniques for the Prediction of Propagation Parameters in Mobile Communications. Application to Microcells and Picocells."** Prof. Felipe Catedra, University of Cantabria, Spain. (Full-day course, Monday, March 17)

Introduction to propagation in PCS. Picocell and microcell scenarios. Geometrical and morphological models, faceted models, DXF formats. Review of GTD-UTD techniques applied to urban propagation problems. Definition of the shadowing problem for simple, second and higher order coupling mechanisms. Application of culling and bounding boxes techniques to the shadowing problems. The Angular Z-Buffer (AZB) algorithm: angular buffer for source, reflected and diffracted rays: Application of the AZB algorithm to the shadowing problems. The Binary Space Partitioning (BSP) Algorithm: tree generation and application to the shadowing problem. Results and comparisons of the AZB and BSP algorithms considering 2D and 3D real cases and simple, double and higher order coupling mechanisms.

3. **"Numerical Optimization in Electromagnetics: Genetic Algorithms,"** Dr. Randy L. Haupt, United States Air Force Academy. (Half-day course, Monday AM, March 17)

Genetic algorithms are "global" numerical optimization methods based on genetic recombination and evolution in nature. These algorithms have been applied to many complex problems including antenna and radar cross section designs. Some of their advantages over conventional optimization techniques include : they 1) optimize with discrete parameters, 2) optimize well with a large number of parameters, 3) explore a vast portion of the cost surface, 4) do not require derivative information, and 5) are ideal for parallel processing. This course begins with a review of conventional numerical optimization techniques and their inadequacies. From there some "global" algorithms are presented with particular emphasis on evolutionary algorithms. Next, a tutorial on genetic algorithms is given, and a variety of applications are presented. Some time will be left for discussing new applications.

SHORT COURSES (cont)

4. **"Transmission Line Matrix (TLM) Modeling of Electromagnetic Fields in Space and Time,"** Prof. Wolfgang J.R. Hoefer, Dept. of Electrical and Computer Engineering, University of Victoria, Canada. (Full-day course, Monday March 17)

The objective of this full-day course is to familiarize participants with the theoretical foundations of time domain TLM and its practical applications to electromagnetic modeling. Emphasis will be on the algorithms and procedures as well as their implementation. The relation between TLM and classical analytical electromagnetics will be stressed throughout the course. The similarities and differences between TLM and the Finite Difference - Time Domain (FD-TD) formulations will be discussed as well. All major features of the TLM method will be demonstrated live in order to animate the theoretical explanations and to make their significance immediately obvious. At the same time, typical examples involving guiding and radiating structures as well as EMI/EMC situations will be solved to demonstrate the capabilities of the method. Major course topics are: 1) The Theoretical Foundations of the TLM Method. 2) Wave properties of 1D, 2D and 3D TLM Networks. 3) Modeling of Linear Media. 4) Modeling of Boundaries. 5) Modeling of Nonlinear Media and Devices, and 6) Applications and Examples.

5. **"Practical EMI/EMC Design and Modeling,"** Prof. Todd Hubing, University of Missouri-Rolla. (Full-day course, Monday, March 17)

There are a large number of computer modeling codes available to assist circuit and system designers in solving or preventing electromagnetic compatibility problems. The intent of this course is to guide the student in selecting and using appropriate computer modeling tools for EMI/EMC applications. The student will learn about the sources of radiation and susceptibility problems, practical EMI/EMC design strategies, and how to develop simple models that represent the salient features of real products. The fundamentals of tools used to calculate radiated emissions will be discussed and the course will provide an overview of the various commercial and non-commercial electromagnetic modeling codes that are available.

6. **"Finite Difference Time Domain Modeling and Applications,"** Prof. Stephen Gedney, Dept. of Electrical Engineering, University of Kentucky and Dr. James Maloney, Georgia Tech. Research Institute. (Full-day course, Friday, March 21)

This short course will provide a comprehensive overview of the finite-difference time-domain (FDTD) method and its application. The course will start out with a fundamental review of the FDTD algorithm and will cover in detail many of its recent advances in the areas of absorbing boundary conditions, including the perfectly matched layer media, complex material modeling, including frequency dependent materials and anisotropic materials, subcell modeling techniques, advanced algorithms which exploit irregular and unstructured grids, and efficient implementations on today's high-performance computers. A large emphasis of the course will be placed on applying the FDTD method to practical problems, including antennas, microwave and digital circuits, electromagnetic scattering, and periodic structures.

7. **"Introduction to RADAR via Physical Wavelets,"** Dr. Gerald Kaiser, Prof. of Mathematical Sciences at UMass-Lowell. (Full-day course, Friday, March 21) **(note! optional book is available for \$28.00)**

This course will include the following: Introduction to physical (electromagnetic and acoustic) wavelets with moving point sources. Models of emission, reflection, and reception. Target trajectory estimation using ambiguity functionals. Reduction to time-scale (wavelet) analysis for monostatic radar with uniformly moving targets. Reduction to time-frequency analysis in the narrowband approximation. Connection with ordinary ambiguity functions. Directivity: Radar with Complex-Source Pulsed Beams. Participants will receive typeset lecture notes. In addition, the instructor's book, *A Friendly Guide to Wavelets*, will be available at a discount. (This book was selected by the Library of Science as Book of the Month in 1995. It was also Springer-Verlag's fifth best-selling mathematics title in February 1996.) For more information, please visit the Web site www.tiac.net/users/gkaiser.

SHORT COURSES (cont)

8. **"Mathematical Software for Computational Electromagnetics,"** Dr. Jovan Lebaric, Naval Postgraduate School, (Full-day course, Friday, March 21)

The short course objective is to introduce MATLAB and MATHCAD software for research and teaching of computational electromagnetics. Each attendee will have a PC with MATLAB and MATHCAD software installed. Course attendees will learn how to use the commercially available state-of-the-art mathematical software (MATHCAD and MATLAB) to solve static, transient and time-harmonic electromagnetic problems efficiently on a PC and visualize the results. The numerical techniques presented will be Method of Moments (MOM) and Finite Differences (FD). Attendees will be provided with sample solutions and working programs, but will also be asked to solve problems on their own. A set of notes and a diskette with sample MATLAB and MATHCAD programs will be provided to each attendee.

9. **"Introduction to FEKO: A Hybrid Method of Moments/Physical Optics (MoM/PO) Code,"** Dr. F.J.C. Meyer, EM Software and Systems, South Africa, and Dr. U. Jakobus, Univ. of Stuttgart, Germany. (Half-day course, Friday PM, March 21)

The MoM has found widespread application to a variety of practical electromagnetic radiation and scattering problems. One major limitation is the memory and CPU time needed when electrically large structures are analyzed. The hybridization of the MoM with the PO approximation yields a technique which can reduce the required memory and CPU time considerably. FEKO is a comprehensive implementation of the MoM with a variety of features. FEKO can analyze: metallic wires and surfaces (perfectly conducting, ohmic losses, skin effects of discrete impedances) in free space or embedded in dielectric or magnetic regions; real ground planes; dielectric and magnetic bodies with or without losses. An automated mesh-generator creates the required line, surface and volume elements. This course will provide an introduction to the computer code FEKO. A brief overview of the MoM/PO theory will be presented. A variety of practical applications and examples will be discussed in detail. At the end of the course, attendees will have an understanding of the theory of the MoM and hybrid MoM/PO techniques; be familiar with all the capabilities of the computer code FEKO; and most importantly know how (and when) to use FEKO for solving real-world electromagnetic problems.

10. **"Radiation Physics,"** Dr. E.K. Miller, (Half-day course, Friday AM, March 21)

All external electromagnetics (EM) arise from the process of radiation. There would be no fields to radiate, propagate or scatter were it not for this phenomenon. In spite of this self-evident truth, our understanding of how and why radiation occurs is relatively superficial from a practical viewpoint. It's true that we are able to determine the near and far fields of rather complex objects subject to arbitrary excitation and can thus perform analysis and design of EM systems. However, if the task is to determine the spatial distribution of radiation from the surface of a given object, the answer becomes less obvious. One way to approach this problem might be to ask, were our eyes sensitive to X-band frequencies and capable of resolving source distribution a few wavelengths in extent, what would be the image of such simple objects as dipoles, circular loops, conical spirals, log-periodic structures, etc. when excited as antennas or scatterers? A variety of measurements, analyses and computations have been made over the years that bear on this question. The goal of this short course will be to summarize available relevant data and observations as well as to offer possibly new perspectives concerning radiation physics from the perspective of both the time and frequency domains. While it may not be possible to provide a quantitative recipe that permits direction computation of a radiation image, a variety of qualitative statements can be made that bear on this question. Participants will be welcome to offer their own examples and observations concerning radiation physics.

MOTELS / HOTEL LIST FOR MARCH 1997 ACES SYMPOSIUM

17-21 MARCH 1997

**** (WITHIN WALKING DISTANCE OF NPS)**

FOR ALL MOTELS IN AREA, WEEKEND RATES MAY BE HIGHER. PLEASE CHECK.

FIRESIDE LODGE ()** (1 star)
1131 10th St. Monterey, CA 93940
Phone: (408) 373-4172 FAX: (408) 655-5640
Rates \$69 Govt, \$69 Conf. (Mention ACES)
Reservations must be made by 17 Feb. 1997

STAGECOACH MOTEL ()** (1 Star)
1111 10th St. Monterey, CA 93940
Phone: (408) 373-3632 FAX: (408)-648-1734
Rates \$60 for everybody. (Mention ACES)
Reservations must be made by 17 Feb. 1997

HYATT HOTEL & RESORT ()** (4 Star)
1 Old Golf Course Rd. Monterey, CA 93940
Phone: (408) 372-1234 FAX: (408)-375-6985
Rates \$99-124. Govt./\$140-155. Conf. (Mention ACES)
Reservations must be made by 17 Feb. 1997

MONTEREY BAY LODGE ()**
55 Camino Aguajito, Monterey, CA 93940
Phone: (408) 372-8057 FAX: (408) 655-2933
Rates: Govt. \$89,10 (17 thru 19th), \$103.55 (20&21)
Non-govt. \$99 + tax, (17thru 19th) \$109.+tax (20&21)

HOLIDAY INN ()** (3 Star)
1000 Aguajito Rd. Monterey, CA 93940
(408) 373-6141 FAX: (408)375-2367
Rates: \$80 Govt; \$119 Conf. (Mention ACES)
Reservations must be made by 17 Feb. 1997

SUPER 8 MOTEL (2 Star)
2050 Fremont St. Monterey, CA. 93940
Phone: (408) 373-3081 FAX: (408) 372-6730
Rates: \$45-51 17th through 20 March

EMBASSY SUITES, HOTEL & CONF. CENTER
1441 Canyon Del Rey, Seaside, CA 93955
Phone (408) 393-1115, Fax: (408) 393-1113
Rates: \$80 Govt, \$135 Conf
No rooms set aside for ACES.

No Blocks of rooms are set aside at Monterey Bay Lodge, Embassy Suites or Super 8 Motel. Call and ask for conference rates!

IMPORTANT INFORMATION FOR ACES ATTENDEES, PLEASE READ.

Hotel room tax exemption requires all of the following documents: (1) Travel Orders, (2) Payment by government issued AMEX card; (3) Govt./Military identification. Regarding Govt orders: prevailing per diem lodging rate at time of arrival will be honored. Attendees on Govt. orders do NOT pay city tax; every other attendee pays city tax!

When you book a room mention that you are attending the "ACES" Conference, and ask for either Government, or Conference rates.

There is NO Conference PARKING at the Naval Postgraduate School or on nearby streets, so we advise you to book a room within walking distance, or plan to use a taxi.

Third Street Gate is the closest gate to the Conference Registration location. Gates open at 0600 (AM) and close at 1800 (6 PM) daily. After 1800 hours, the Main Gate (between Ninth and Tenth Streets), is the only gate open.

AIRLINE INFORMATION

The following airlines make connections from Los Angeles and San Francisco, CA. to Monterey, CA: American, United, Delta/Sky West, and US Air.

There is no connection directly from San Jose, CA to Monterey, CA. You can fly to San Jose, but then ground transportation must be used. Monterey-Salinas Airbus serves San Francisco International (SFO) and San Jose International (SJC). There are five departures daily from Monterey and Salinas, arriving at both SFO & SJC, appx. (2-4) hours later. There are also the same departures from SFO & SJC. For information and an updated schedule, phone (408) 442-2877 or (800) 291-2877.

THINGS TO DO AND SEE IN THE MONTEREY BAY AREA

There are many activities for children and adults not attending the Conference. The colorful blue Monterey Bay is a vision of historic Monterey, rich with natural beauty and many attractions from Fisherman's Wharf, (be sure to try the seafood cocktails), to Cannery Row, the Monterey Adobes and city parks, the Monterey Bay Aquarium, Maritime Museum of Monterey, and Pacific Grove Museum of Natural History. The "Artichoke Capital of the World" is only 15 miles from Monterey, in Castroville. Other things to do include: driving the 17-Mile Drive in Pebble Beach; Whale watching, bicycle riding, roller blading, surfing, ocean kyaking, in Pacific Grove; taking a stroll on the white sandy beach in Carmel, a visit to Mission San Carlos Borromeo Del Rio Carmelo, in Carmel, etc. The Monterey Peninsula has 20 Golf Courses. Carmel has many Art Galleries. For more information, call the Monterey Peninsula Chamber of Commerce, Visitors and Convention Bureau at (408) 649-1770.

ACES CONFERENCE

TO DAYS INN & EMBASSY SUITES HOTELS

NO PARKING ON CAMPUS

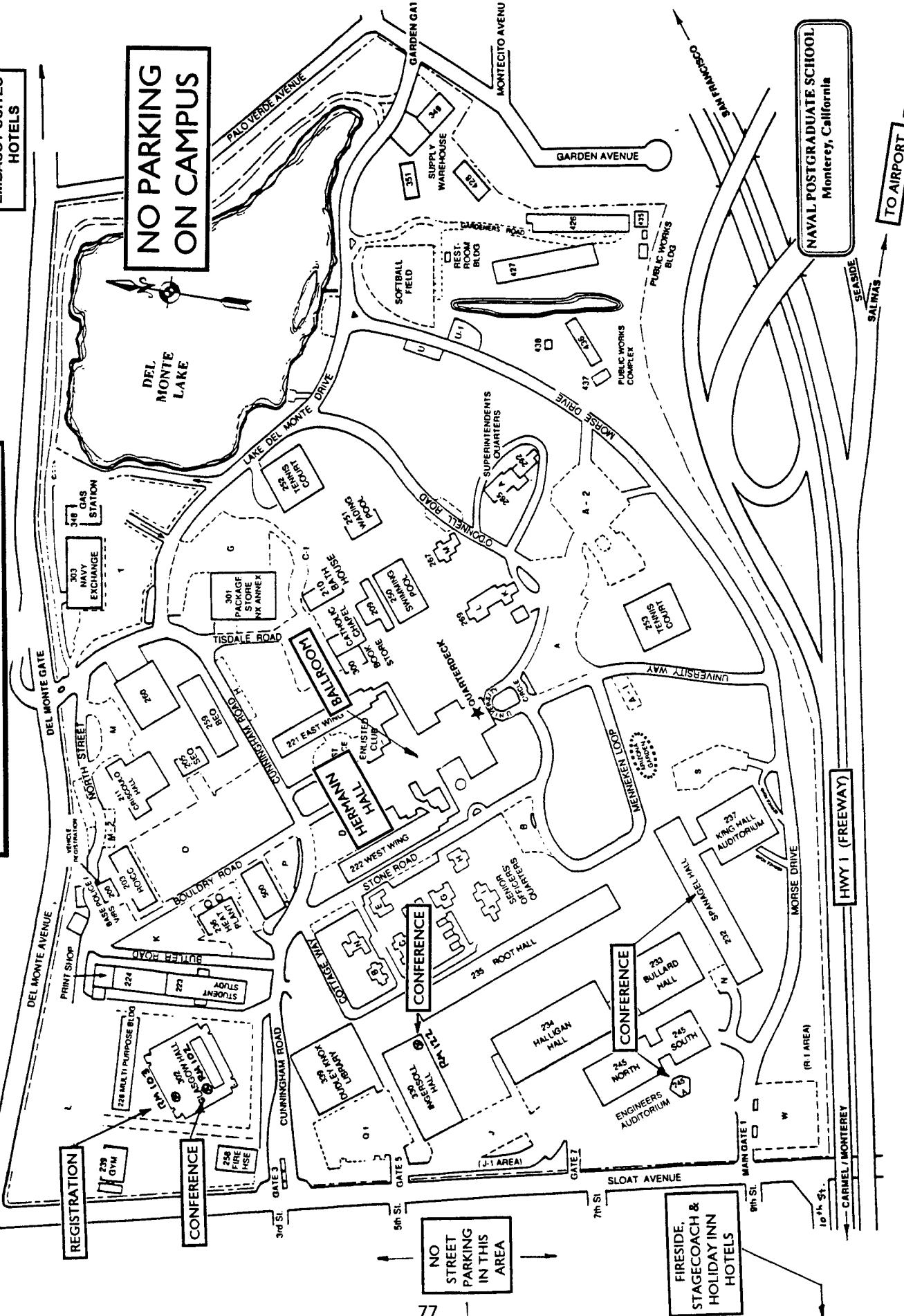

REGISTRATION

CONFERENCE

CONFERENCE

CONFERENCE

NO STREET PARKING IN THIS AREA

FIRESIDE, STAGECOACH & HOLIDAY INN HOTELS

NAVAL POSTGRADUATE SCHOOL
Monterey, California

HYATT REGENCY

CALL FOR PAPERS

THE APPLIED COMPUTATIONAL ELECTROMAGNETICS SOCIETY
ANNOUNCES A SPECIAL ISSUE OF THE ACES JOURNAL ON

COMPUTATIONAL ELECTROMAGNETICS AND HIGH-PERFORMANCE COMPUTING

The Applied Computational Electromagnetics Society is pleased to announce the publication of a 1998 Special Issue of the *ACES Journal on Computational Electromagnetics and High-Performance Computing*. The primary objective of this special issue is to present a survey of the present state of the art of high-performance computing applied to computational electromagnetics.

Papers submitted should concentrate on computational aspects of electromagnetics: these include problem sizes; operation counts; parallel algorithms; and hardware aspects (although the last should avoid great technicalities). High-performance computing includes supercomputing, high-performance workstations and multi-processor networks. Complete simulation packages that consider the integration of mesh generation, electromagnetic solvers, and post-processing are especially relevant. Algorithms developments (such as the Fast Multipole Method) are only appropriate in this context if specifically related to high speed computation. Similarly, papers dealing only with high speed computation, without a CEM application, will be of limited suitability.

SUGGESTED TOPICS

- Supercomputers
- Multi-processor networks
- Optimization methods
- Parallel environments - especially portable ones such as PVM
- Computational Electromagnetics Applications including: Moment Method/Integral and Integro-Differential Equation methods; Finite Element method; Finite Difference Time Domain method; Transmission Line Modeling method; Asymptotic methods (GTD, UTD, etc); other methods such as MMP; Linear Algebra techniques for these methods where appropriate.
- High-performance workstations
- Performance modelling
- Adaptive methods

DEADLINE FOR PAPERS IS JULY 1, 1997

GUEST EDITORS

David Davidson
EE Engineering Department
University of Stellenbosch
Stellenbosch, SOUTH AFRICA 7600
Tel: +27 21 808 4458
Fax: +27 21 808 4981
e-mail: davidson@firga.sun.ac.za

Tom Cwik
Jet Propulsion Laboratory
California Institute of Technology
Pasadena, CA USA 91109
Tel: 818-354-4386
Fax: 818-393-3505
e-mail: cwik@yosemite.jpl.nasa.gov

Please submit papers, clearly marked
"FOR CEM&HPC SI"
to avoid possible confusion, to:

Duncan Baker
Editor-in-Chief, ACES Journal
EE Department, University of Pretoria
0002 Pretoria, SOUTH AFRICA
Tel: 27 12 420 2775; Fax: 27 12 43 3254
e-mail: duncan.baker@ee.up.ac.za

THE APPLIED COMPUTATIONAL ELECTROMAGNETICS SOCIETY

13TH ANNUAL REVIEW OF PROGRESS

IN APPLIED COMPUTATIONAL ELECTROMAGNETICS

March 17 - 21, 1997
 Naval Postgraduate School
 Monterey, CA

Registration Form

Please print (NOTE: CONFERENCE REGISTRATION FEE DOES NOT INCLUDE ACES MEMBERSHIP FEE OR SHORT COURSE FEE)

LAST NAME _____ FIRST NAME _____ MIDDLE INITIAL _____

COMPANY/ORGANIZATION/UNIVERSITY _____ DEPARTMENT/MAIL STATION _____

MAILING ADDRESS _____

CITY _____ PROVINCE/STATE _____ COUNTRY _____ ZIP/POSTAL CODE _____

TELEPHONE _____ FAX _____ E-MAIL ADDRESS _____ AMATEUR RADIO CALL SIGN _____

	BEFORE 3/1/97	3/1/96 TO 3/11/97	AFTER 3/11/97
ACES MEMBER	<input type="checkbox"/> \$ 255	<input type="checkbox"/> \$ 270	<input type="checkbox"/> \$ 285
NON-MEMBER	<input type="checkbox"/> \$ 295	<input type="checkbox"/> \$ 310	<input type="checkbox"/> \$ 325
STUDENT/RETIRED/UNEMPLOYED	<input type="checkbox"/> \$ 115 (no proceedings)	<input type="checkbox"/> \$ 115	<input type="checkbox"/> \$ 115
STUDENT/RETIRED/UNEMPLOYED	<input type="checkbox"/> \$ 150 (includes proceedings)	<input type="checkbox"/> \$ 150	<input type="checkbox"/> \$ 150
BANQUET <input type="checkbox"/> Meat <input type="checkbox"/> Fish	<input type="checkbox"/> \$ 30	<input type="checkbox"/> \$ 30	<input type="checkbox"/> \$ 30

Short Courses

"FINITE ELEMENTS FOR ELECTROMAGNETICS" by Dr. J. Brauer and Dr. Z. Cendes, Full-day - Monday	<input type="checkbox"/> \$ 140	<input type="checkbox"/> \$ 150	<input type="checkbox"/> \$ 160
"RAY-TRACING TECHNIQUES FOR THE PREDICTION OF PROPAGATION PARAMETERS IN MOBILE COMMUNICATIONS. APPLICATIONS TO MICROCELLS AND PICOCELLS" by Prof. F. Catedra, Full-day - Monday	<input type="checkbox"/> \$ 140	<input type="checkbox"/> \$ 150	<input type="checkbox"/> \$ 160
"NUMERICAL OPTIMIZATION IN ELECTROMAGNETICS: GENETIC ALGORITHMS" by Dr. R.L. Haupt, Half-day, Monday, AM	<input type="checkbox"/> \$ 90	<input type="checkbox"/> \$ 100	<input type="checkbox"/> \$ 110
"TRANSMISSION LINE MATRIX (TLM) MODELING OF ELECTROMAGNETIC FIELDS IN SPACE AND TIME" , by Prof. W.J.R. Hoefler, Full-day - Monday	<input type="checkbox"/> \$ 140	<input type="checkbox"/> \$ 150	<input type="checkbox"/> \$ 160
"PRACTICAL EMI/EMC DESIGN AND MODELING" by Prof. T. Hubing, Full-day, Monday	<input type="checkbox"/> \$ 140	<input type="checkbox"/> \$ 150	<input type="checkbox"/> \$ 160
"FINITE DIFFERENCE TIME DOMAIN MODELING AND APPLICATIONS" by Prof. S. Gedney and Dr. J. Maloney, Full-day - Monday	<input type="checkbox"/> \$ 140	<input type="checkbox"/> \$ 150	<input type="checkbox"/> \$ 160
"INTRODUCTION TO RADAR VIA PHYSICAL WAVELETS" , by Dr. G. Kaiser Full-day - Friday	<input type="checkbox"/> \$ 140	<input type="checkbox"/> \$ 150	<input type="checkbox"/> \$ 160
"MATHEMATICAL SOFTWARE FOR COMPUTATIONAL ELECTROMAGNETICS" by Dr. J. Lebaric, Full-day - Friday	<input type="checkbox"/> \$ 140	<input type="checkbox"/> \$ 150	<input type="checkbox"/> \$ 160
"INTRODUCTION TO FEKO: A HYBRID METHOD OF MOMENTS/PHYSICAL OPTICS (MoM/PO) CODE" , by Dr. F.J.C. Meyer, Half-day - Friday, PM	<input type="checkbox"/> \$ 90	<input type="checkbox"/> \$ 100	<input type="checkbox"/> \$ 110
"RADIATION PHYSICS" by Dr. E.K. Miller, Half-day, Friday, AM	<input type="checkbox"/> \$ 90	<input type="checkbox"/> \$ 100	<input type="checkbox"/> \$ 110

Non-USA participants: Prices are in U.S. dollars. All currencies must be converted to U.S. dollars payable by banks with U.S. affiliates. (1) Bank Checks, must have U.S. address of bank; (2) Traveler's Checks (in U.S. \$\$); (3) International Money Order drawn in U.S. funds, payable in U.S. and to "ACES", (4) Credit Cards: Visa, MasterCard, Discover and AmEx.

CREDIT CARD USERS: SIGNATURE AND ADDRESS OF CARD HOLDER IS MANDATORY. IF YOU ARE PAYING VIA ANOTHER PERSONS CARD, HE/SHE MUST PRINT AND SIGN THEIR NAME.

PRINT CARD HOLDER NAME: _____

CREDIT CARD HOLDER SIGNATURE: _____

CREDIT CARD EXPIRATION DATE: _____

PAYMENT METHOD:

- Check (PAYABLE TO ACES)
 Traveler's checks
 International Money Order
 Credit Card
 Visa
 MasterCard
 AmEx
 Discover

CREDIT CARD ACCOUNT #

January 1997

ACES MEMBERSHIP - NEWSLETTER & JOURNAL SUBSCRIPTION FORM

please print

LAST NAME _____ FIRST NAME _____ MIDDLE INITIAL _____

COMPANY/ORGANIZATION/UNIVERSITY _____ DEPARTMENT/MAIL STATION _____

PLEASE LIST THE ADDRESS YOU WANT USED FOR PUBLICATIONS

MAILING ADDRESS _____

CITY _____ PROVINCE/STATE _____ COUNTRY _____ ZIP/POSTAL CODE _____

TELEPHONE _____ FAX _____ AMATEUR RADIO CALL SIGN _____

E-MAIL ADDRESS _____ E-MAIL ADDRESS CAN BE INCLUDED IN ACES DATABASE YES NO

PERMISSIONS GRANTED TO HAVE MY NAME PLACED ON MAILING LISTS WHICH MAY BE SOLD YES NO

CURRENT SUBSCRIPTION PRICES

AREA	INDIVIDUAL SURFACE MAIL	INDIVIDUAL AIRMAIL	ORGANIZATIONAL (AIRMAIL ONLY)
U.S. & CANADA	() \$65	() \$65	() \$115
MEXICO, CENTRAL & SOUTH AMERICA	() \$68	() \$70	() \$115
EUROPE, FORMER USSR, TURKEY, SCANDINAVIA	() \$68	() \$78	() \$115
ASIA, AFRICA, MIDDLE EAST & PACIFIC RIM	() \$68	() \$85	() \$115

FULL-TIME STUDENT/RETIRED/UNEMPLOYED RATE IS \$25 FOR ALL COUNTRIES

Non-USA participants: Prices are in U.S. dollars. All currencies must be converted to U.S. dollars payable by banks with U.S. affiliates. (1) Bank Checks, must have U.S. address of bank; (2) Traveler's Checks (in U.S. \$\$); (3) U.S./International Money Order drawn in U.S. funds, payable in U.S., (4) Credit Cards: Visa, MasterCard, Amex and Discover.

PAYMENT METHOD: ALL CHECKS/TRAVELER'S CHECKS/MONEY ORDERS ARE PAYABLE TO "ACES"

- CHECK (PAYABLE TO ACES)
 TRAVELER'S CHECKS
 INTERNATIONAL MONEY ORDER
 CREDIT CARD
 VISA
 MASTERCARD
 AMEX
 DISCOVER

CREDIT CARD USERS

SIGNATURE AND ADDRESS OF CARD HOLDER IS MANDATORY.

IF YOU ARE PAYING VIA ANOTHER PERSONS CARD, HE/SHE MUST PRINT AND SIGN NAME AND ADDRESS.

PRINT CARD HOLDER NAME: _____

CREDIT CARD HOLDER SIGNATURE: _____

CREDIT CARD EXPIRATION DATE: _____ / _____

CREDIT CARD HOLDER ADDRESS, IF CARD IS NOT YOUR OWN. _____

CREDIT CARD ACCOUNT #

January 1997

ADVERTISING RATES		
	FEE	PRINTED SIZE
Full page	\$200.	7.5" x 10.0"
1/2 page	\$100.	7.5" x 4.7" or 3.5" x 10.0"
1/4 page	\$ 50	3.5" x 4.7"
<p>All ads must be camera ready copy.</p> <p>Ad deadlines are same as Newsletter copy deadlines.</p> <p>Place ads with Ray Perez, Newsletter Editor, Martin Marietta Astronautics, MS 58700, PO Box 179, Denver, CO 80201, USA. The editor reserves the right to reject ads.</p>		

DEADLINE FOR THE SUBMISSION OF ARTICLES	
<u>Issue</u>	<u>Copy Deadline</u>
March	January 13
July	May 25
November	September 25

For further information on the **ACES JOURNAL**, contact Prof. Duncan Baker.

For the **ACES NEWSLETTER** send copy to Ray Perez in the following formats:

1. A hardcopy.
2. Camera ready hardcopy of any figures.
3. If possible also send text on a floppy disk. We can read any version of MICROSOFT-WORD and ASCII files on both IBM and Macintosh disks. On IBM disks we can also read WORDPERFECT, WORDSTAR, and LATEX files. If any software other than MICROSOFT WORD has been used on Macintosh Disks, contact the Managing Editor, Richard W. Adler **before** submitting a diskette. If it is not possible to send a Macintosh disk then the hardcopy should be in Courier font **only**, for scanning purposes.

