

WL-TR-97-1002

MODELING AND SIMULATION OF MMICS
AND INTERCONNECTS IN MICROWAVE PACKAGES



HARLES J TRANTANELLA

HITTITE MICROWAVE CORPORATION
21 CABOT ROAD
WOBURN MA 01801

NOVEMBER 1996

FINAL REPORT FOR 05/01/96-11/01/96

APPROVED FOR PUBLIC RELEASE; DISTRIBUTION IS UNLIMITED.

19970226 047

AVIONICS DIRECTORATE
WRIGHT LABORATORY
AIR FORCE MATERIEL COMMAND
WRIGHT PATTERSON AFB OH 45433-7623

DTIC QUALITY INSPECTED 1

REPORT DOCUMENTATION PAGE

Form Approved
OMB No. 0704-0188

Public reporting burden for this collection of information is estimated to average 1 hour per response, including the time for reviewing instructions, searching existing data sources, gathering and maintaining the data needed, and completing and reviewing the collection of information. Send comments regarding this burden estimate or any other aspect of this collection of information, including suggestions for reducing this burden, to Washington Headquarters Services, Directorate for Information Operations and Reports, 1215 Jefferson Davis Highway, Suite 1204, Arlington, VA 22202-4302, and to the Office of Management and Budget, Paperwork Reduction Project (0704-0188), Washington, DC 20503.

1. AGENCY USE ONLY (Leave blank)	2. REPORT DATE November 18, 1996	3. REPORT TYPE AND DATES COVERED Final, May 1996-November 1996
----------------------------------	--	--

4. TITLE AND SUBTITLE Modeling and Simulation of MMICs and Interconnects in Microwave Packages	5. FUNDING NUMBERS C F33615-96-C-1878 PE 65502 PR 3005 TA 11 WU EC
--	--

6. AUTHOR(S) Charles J. Trantanella, Senior Engineer	
--	--

7. PERFORMING ORGANIZATION NAME(S) AND ADDRESS(ES) Hittite Microwave Corporation 21 Cabot Road Woburn, MA 01801	8. PERFORMING ORGANIZATION REPORT NUMBER HMC 96147
---	--

9. SPONSORING/MONITORING AGENCY NAME(S) AND ADDRESS(ES) AVIONICS DIRECTORATE WRIGHT LABORATORY AIR FORCE MATERIEL COMMAND WRIGHT PATTERSON AFB OH 45433-7623 POC: Bradley Paul, WL/AADI, 937-255-4557 x 3442	10. SPONSORING/MONITORING AGENCY REPORT NUMBER WL-TR-97-1002
--	--

11. SUPPLEMENTARY NOTES
THIS IS A SMALL BUSINESS INNOVATION RESEARCH (SBIR) PHASE I REPORT

12a. DISTRIBUTION/AVAILABILITY STATEMENT APPROVED FOR PUBLIC RELEASE; DISTRIBUTION IS UNLIMITED.	12b. DISTRIBUTION CODE
--	------------------------

13. ABSTRACT (Maximum 200 words)

Two structures frequently encountered in modern day microwave subsystems are multi-chip modules (MCMs) and highly integrated monolithic microwave integrated circuits (MMICs). As these circuits become denser and more compact, electromagnetic simulation must be used to accurately predict the interaction between elements. In this report, we evaluate a number of commercially available electromagnetic simulation tools appropriate for the needs of an MCM or an MMIC designer. We start by offering a qualitative comparison of twelve simulators against our performance criteria, developed to address key issues important to electromagnetic simulation. Next, we report on two benchmarking studies which compared the performance of a number of different simulation tools. Finally, we present our conclusions regarding the choice of a particular simulation tool to best fit the needs of the designer.

14. SUBJECT TERMS Electromagnetic Simulation, benchmarking	15. NUMBER OF PAGES 58
	16. PRICE CODE

17. SECURITY CLASSIFICATION OF REPORT Unclassified	18. SECURITY CLASSIFICATION OF THIS PAGE Unclassified	19. SECURITY CLASSIFICATION OF ABSTRACT Unclassified	20. LIMITATION OF ABSTRACT SAR
--	---	--	--

NOTICE

WHEN GOVERNMENT DRAWINGS, SPECIFICATIONS, OR OTHER DATA ARE USED FOR ANY PURPOSE OTHER THAN IN CONNECTION WITH A DEFINITE GOVERNMENT-RELATED PROCUREMENT, THE UNITED STATES GOVERNMENT INCURS NO RESPONSIBILITY OR ANY OBLIGATION WHATSOEVER. THE FACT THAT THE GOVERNMENT MAY HAVE FORMULATED OR IN ANY WAY SUPPLIED THE SAID DRAWINGS, SPECIFICATIONS, OR OTHER DATA, IS NOT TO BE REGARDED BY IMPLICATION, OR OTHERWISE IN ANY MANNER CONSTRUED, AS LICENSING THE HOLDER, OR ANY OTHER PERSON OR CORPORATION; OR AS CONVEYING ANY RIGHTS OR PERMISSION TO MANUFACTURE, USE, OR SELL ANY PATENTED INVENTION THAT MAY IN ANY WAY BE RELATED THERETO.

THIS REPORT IS RELEASABLE TO THE NATIONAL TECHNICAL INFORMATION SERVICE (NTIS). AT NTIS, IT WILL BE AVAILABLE TO THE GENERAL PUBLIC, INCLUDING FOREIGN NATIONS.

THIS TECHNICAL REPORT HAS BEEN REVIEWED AND IS APPROVED FOR PUBLICATION.

BRADLEY J. PAUL
Multi-Chip Integration Branch
Electron Devices Division

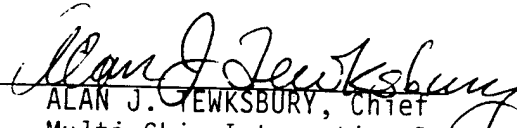
ALAN J. TEWKSBURY, Chief
Multi-Chip Integration Branch
Electron Devices Division

FOR THE COMMANDER:

ROBERT T. KEMERLEY, Chief
Electron Devices Division
Avionics Directorate

IF YOUR ADDRESS HAS CHANGED, IF YOU WISH TO BE REMOVED FROM OUR MAILING LIST, OR IF THE ADDRESSEE IS NO LONGER EMPLOYED BY YOUR ORGANIZATION PLEASE NOTIFY WL/AADI ___ WRIGHT-PATTERSON AFB OH 45433- 7623 ___ TO HELP MAINTAIN A CURRENT MAILING LIST.

Copies of this report should not be returned unless return is required by security considerations, contractual obligations, or notice on a specific document.

TABLE OF CONTENTS

ACKNOWLEDGEMENTS	4
1.0 INTRODUCTION	5
2.0 SIMULATOR EVALUATION	8
2.1 Identification of Electromagnetic Simulation Tools	8
2.2 The Performance Criteria	10
2.2.1 Computer Platform and Hardware Requirements	11
2.2.2 CAD Interface	11
2.2.3 Mesh Generation and Limitations	16
2.2.4 Optimization	18
2.2.5 Presentation of Results	20
2.2.6 Customer Support	20
2.2.7 Unique Features	22
2.2.7.1 EM (Sonnet Software)	22
2.2.7.2 IE3D (Zeland Software)	22
2.2.7.3 Maxwell Strata (Ansoft)	24
2.2.7.4 Microwave Explorer (Compact Software)	24
2.2.7.5 Momentum (Hewlett-Packard)	24
2.2.7.6 SFPMIC+ (Jansen Microwave)	25
2.2.7.7 HFSS (Hewlett-Packard)	25
2.2.7.8 MAFIA (CST)	25
2.2.7.9 Maxwell Eminence (Ansoft)	25
2.2.7.10 Micro-Stripes (KCC)	26
2.2.7.11 Quicksilver (Sandia National Laboratory)	26
2.2.7.12 Quickwave 3D (Warsaw University)	27
2.3 Final Comments on the Performance Criteria	27

TABLE OF CONTENTS (cont'd)

3.0	SIMULATOR BENCHMARKING	28
3.1	MEE Benchmarks	29
3.2	MMWCAE Benchmarking	36
3.2.1	Standard Stripline Benchmark (April 1994)	38
3.2.2	Spiral Inductor Benchmark (April 1991)	42
3.2.3	Bandpass Filter Network (April 1994)	45
3.2.4	MIC Bandpass Filter (March 1995)	48
3.2.5	Interdigitated Capacitor (April 1992)	48
3.2.6	Summary of MMWCAE Benchmarks	53
4.0	CONCLUSIONS	54
	REFERENCES	55

ACKNOWLEDGEMENTS

The completion of this work was made possible by the help of many individuals and their respective corporations. The authors would like to thank the following people (in no particular order) for their time spent answering our questions, and for their general enthusiasm of this project:

Robert Steff and Larry Williams, Ansoft Corporation

Brian Rowe and Marc Saffian, Compact Software

Tom Costas, Hewlett-Packard

Andreas Meyer, Jansen Microwave GmbH

Jim Wilhite, KCC

Peter Hahne and Ralf Ehmann, Computer Simulation Technology (CST GmbH)

John Bandler, Optimization Systems Associates

Wojciech Gwarek, Warsaw University of Technology

Michael Pasik and Mark Kiefer, Sandia National Laboratory

Jim Rautio and Jim Merrill, Sonnet Software

Thomas Lam, Zeland Software

1.0 INTRODUCTION

Two structures frequently encountered in modern day microwave subsystems are multi-chip modules (MCMs) and highly integrated monolithic microwave integrated circuits (MMICs). As the individual MMICs become smaller and the MCMs become denser, unwanted performance problems arise from electromagnetic coupling between the various components. All too often the designer must fabricate the MMIC or build the MCM before these coupling problems can be identified and corrected. Accurate prediction of circuit performance through simulation tools, however, gives the designer the ability to fix these problems before fabrication, thus saving time and money.

The traditional method of simulating MCMs and highly integrated MMICs involves circuit theory, where lumped circuit elements (such as capacitors, inductors, etc.) and analytical expressions for microstrip, stripline, or coplanar phenomenon are used to model the interactive coupling and loss between devices. However, as designs become complex, these models cannot fully account for all of the mutual coupling between elements. To simulate all of the coupling, we must use electromagnetic techniques based on field theory, especially as the operating frequencies approach 60 GHz and beyond.

Over the past ten years, a host of commercially available electromagnetic simulation tools have been developed to analyze the electromagnetic coupling in a circuit. These simulators can be divided into two categories based upon the number of spatial dimensions allowed for the defining of material parameters and electric currents. One category is the two and a half dimensional (2.5D) simulator, commonly referred to as the planar electromagnetic simulator. In 2.5D simulators, material parameters can only vary in two of the three rectangular dimensions, although electric currents are allowed to flow in the third dimension (Note: this definition of 2.5D simulators is slightly outdated, since some planar 2.5D simulators can now incorporate truly three dimensional structures. However, we will refer to planar simulators as 2.5D for historical reasons.). In general, 2.5D simulation tools use the method of moments to numerically solve for the electric currents on the metalization present in the circuit. Planar 2.5D simulators are optimized for the simulation of planar structures such as stripline, microstrip and coplanar circuit topologies. As a result, 2.5D simulation tools are best applied to the modeling of single, highly integrated MMICs. Consequently, 2.5D simulation tools are not

appropriate for the simulation of MCMs.

The second type of electromagnetic simulator is the three dimensional (3D) simulator. In 3D simulators, material properties can vary and electric currents can flow in any general direction. A number of different solution methods are employed by 3D simulators, including frequency domain techniques such as the finite element method, and time domain techniques such as the finite-difference time domain method and the transmission line matrix method. In general, 3D simulators solve for the electric and magnetic fields outside of the metalization. Frequency domain techniques solve for these fields a single frequency at a time, whereas time domain techniques solve for the fields at discrete instances in time. The volume meshing techniques employed by 3D simulators are typically an order of magnitude slower in solution time when compared to the method of moments techniques applied to planar type problems. As a result, 3D simulation tools are not appropriate for the simulation of planar structures such as highly integrated MMICs. However, 3D simulation tools are well suited for the simulation of MCMs since these structures are not, in general, planar.

In this report, we present a general comparison of commercially available 2.5D and 3D electromagnetic simulation tools. Section 2 presents an evaluation of some of these simulators against a performance criteria. This performance criteria was developed to address key issues important to electromagnetic simulators such as the supported computer platforms, the CAD interface into and out of the simulator, and the optimization capabilities of the simulator. Section 3 discusses the benchmarking of electromagnetic simulation software. We first present an overview of benchmarking in general, followed by a summary of two benchmarking studies published in the open literature. One of these studies was published as a two-part series in *Microwave Engineering Europe*, while the other study was gathered from results published in the MIC Simulation Column of the *International Journal of Microwave and Millimeter-Wave Computer-Aided Engineering*. Finally, in Section 4, we present our conclusions.

The goal of this research effort was not to determine which electromagnetic simulation tool is "best". The question of "best" in terms of electromagnetic software cannot be answered for any general set of conditions. Every designer will have different concerns and different needs with regards to an electromagnetic simulation tool. Therefore, the goal of this research is to provide the designer, especially one not familiar with electromagnetic simulators, with a sense of the issues concerning

electromagnetic simulation tools, so they can best decide which tool is appropriate for their needs. In addition, we discuss methods of evaluating the different software packages by presenting benchmark examples and rationales. The goal of this benchmarking discussion is to help the designer understand the complexities behind simulation benchmarking. Ultimately, it is the designer who will benefit from the use of electromagnetic simulation tools, but it is also the designer who must understand how to best achieve these benefits.

2.0 SIMULATOR EVALUATION

In this section, we present our qualitative evaluation of the various electromagnetic simulation tools. Again, the goal of this evaluation was not to determine which simulation tool is “best”, but rather to identify some of the major software developers, comment on the strengths of each of the tools, and list some of the unique features of each tool. To accomplish this evaluation, we developed a performance criteria to address key issues regarding electromagnetic simulation. This performance criteria allowed us to ask specific questions of each simulator and combine the responses of each simulator into one presentation. Therefore, we can identify the similarities and differences between the different software packages.

In the sections below, we start by first identifying the simulation tools we have chosen for evaluation. Next, we present the performance criteria used to evaluate the simulators. Finally, we summarize the different simulators against our performance criteria. We note that in our evaluation, we have generally separated the 2.5D simulators from the 3D simulators, since these tools are best utilized to solve different problems.

2.1 Identification of Electromagnetic Simulation Tools

During the course of this research program, we identified many commercial electromagnetic simulators. After careful consideration, however, we decided to narrow our evaluation against our performance criteria to six 2.5D simulation tools [1-6] and six 3D tools [7-12]. A listing of the simulation software we chose to evaluate is given in Table 2-1. This table is by no means exhaustive and does not contain every commercial electromagnetic simulator that is currently available for purchase. We do not claim nor do we mean to imply in any way that the simulation tools listed above are better than any we have left out of our evaluation. However, we believe this list represents a majority of simulation tools used by designers in industry and government laboratories worldwide.

One popular simulation tool we left out of our evaluation was Microwave Lab by MacNeal-Schwendler. This simulator was recently acquired by Ansoft Corporation, who also publish Maxwell Eminence and Maxwell Strata. As a result of this purchase, the future availability of Microwave Lab

2.5D		3D	
Simulator	Developer	Simulator	Developer
EM	Sonnet Software	HFSS	Hewlett-Packard
IE3D	Zeland Software	MAFIA	CST
Maxwell Strata	Ansoft	Maxwell Eminence	Ansoft
Microwave Explorer	Compact Software	Micro-Stripes	KCC
Momentum	Hewlett-Packard	Quicksilver	Sandia Laboratory
SFPMIC+	Jansen Microwave	Quickwave 3D	Warsaw University

HMC 6013

Table 2.1 Listing of the electromagnetic simulation tools evaluated against our performance criteria.

is unclear. Therefore, we decided to exclude Microwave Lab from our evaluation.

2.2 The Performance Criteria

In order to qualitatively evaluate the different simulation tools, we first developed a set of performance criteria. As we mentioned earlier, the performance criteria was designed to address key issues important to electromagnetic simulation, provide a qualitative comparison of the different simulation tools over a number of topics, and present the evaluation in a concise yet informative manner. This criteria was developed from an earlier proposed set of requirements for electromagnetic simulation tools [13]. Although this original set of requirements was developed before the maturity of current electromagnetic simulation tools, a number of issues raised in this discussion are still important today. A listing of the categories in our performance criteria is given below:

- 1) Computer platform and hardware requirements.
- 2) CAD interface.
- 3) Mesh generation and limitations.
- 4) Optimization capabilities.
- 5) Presentation of results.
- 6) Customer support and ease of use.
- 7) Unique features.

In the next seven sections, we first discuss the motive behind each criteria followed by a summary of our findings for each of the simulation tools. The information cited in the following sections was derived from the literature published by and private conversations with each of the software developers. We would like to mention that all of the information presented below, to the best of our knowledge, is accurate at the time of publication. However, the reader is strongly encouraged to verify any information that they deem important, since the software developers are constantly upgrading their products and introducing new features.

2.2.1 Computer Platform and Hardware Requirements

Our first performance criteria addresses the computer hardware requirements for the various simulation tools. This criteria identifies the computer platforms supported by each software developer along with the minimum recommended RAM and hard disk requirements. We present our summary of hardware requirements for workstation platforms in Table 2-2, and PC platforms in Table 2-3. In these tables, we list the simulator name, the supported platform (or PC operating system), and the memory requirements (RAM and hard disk space). We note that the entry "Y" in the table indicates the platform is supported, whereas "na" indicates the platform is not supported at this time. We also note that the RAM and hard disk requirements listed in these two tables are minimum values, and all of the software developers recommend at least 2-3 times the minimum listed RAM for the analysis of moderately to highly complex problems.

Let us first consider the 2.5D simulation tools listed in Tables 2-2 and 2-3. We note that most of the 2.5D simulation tools do not support the Silicon Graphics (SGI) or Digital (DEC) computing platforms. In addition, few support the PC/Windows platform, but in all likelihood this will change over the coming years, as powerful PCs become a viable alternative to workstations. Also, it appears that Momentum recommends a minimum amount of RAM and hard disk space that is significantly larger than the other 2.5D simulators.

For the 3D simulation tools, we note that the Sun SPARC network is supported by all simulators except Quicksilver. However, we do note that Quicksilver is supported on the Cray supercomputer, and in the future Quicksilver will be supported on the Intel Paragon platform. We also note that HFSS has minimum hard disk and RAM requirements that are significantly larger than the rest of the 3D simulators. Finally, we note that Eminence and Quickwave 3D are the only 3D tools currently available for the PC, although in all likelihood other developers will support this platform in the near future.

2.2.2 CAD Interface

The second item in our performance criteria is the CAD interface. This criteria addresses the ability of the software to transfer layout information into and out of the simulator, and its ability to

UNIX Platforms								
2.5D Simulators	Minimum RAM	Minimum Hard Disk	HP9000	Sun SPARC	IBM RS/6000	SGI	DEC	Other
EM	16MB	35MB	Y	Y	Y	na	na	
IE3D	16MB	6MB	na	Y(1)	na	na	na	
Maxwell Strata	16MB	100MB (2)	Y	Y	Y	Y	na	
Microwave Explorer	32MB	30MB	Y	Y	na	na	na	
Momentum	32MB (3)	400MB	Y	Y	Y	na	Y	
SFPMIC+	16MB	40MB	Y	Y	Y	na	Y	
3D Simulators	Minimum RAM	Minimum Hard Disk	HP9000	Sun SPARC	IBM RS/6000	SGI	DEC	Other
HFSS	64MB (4)	600MB (5)	Y	Y	na	na	Y	
MAFIA	16MB	150MB	Y	Y	Y	na	Y	
Maxwell Eminence	16MB	100MB (2)	Y	Y	Y	Y	na	
Micro-Stripes	16MB	40MB	Y	Y	na	na	na	
Quicksilver	32MB	30MB	Y	Y(6)	na	Y(6)	Y(6)	Cray (7)
Quickwave 3D	16MB		Y	Y	Y	Y	Y	

Notes:

1. IE3D solver can operate in batch mode on the SPARC platform.
2. 32MB required for swap space.
3. Requires 64MB RAM for visualization of results.
4. 64MB required for lossless simulations, 128MB required to include loss.
5. Tape drive required to install program.
6. Graphical preprocessor and post processor are supported on these platforms.
7. A port to the Intel Paragon system is planned.

HMC 6014

Table 2.2 Summary of hardware requirements for the simulation tools on workstation platforms.

PC Platforms					
2.5D Simulators	Minimum RAM	Minimum Hard Disk	Windows 3.1	Windows NT	Windows 95
EM	16MB	35MB	Y	Y	Y
IE3D	16MB	6MB	Y	Y(1)	Y
Maxwell Strata	16MB	80MB	na	Y	na
Microwave Explorer	na	na	na	na	na
Momentum	na	na	na	na	na
SFPMIC+	na	na	na	na	na
3D Simulators	Minimum RAM	Minimum Hard Disk	Windows 3.1	Windows NT	Windows 95
HFSS	na	na	na	na	na
MAFIA	na	na	na	na	na
Maxwell Eminence	64MB	50MB	na	Y	na
Micro-Stripes	64MB	40MB	na	na	Y(2)
Quicksilver	na	na	na	na	na
Quickwave 3D	16MB		Y	Y	Y

Notes:

1. Windows NT Version requires 32MB of RAM.
2. Available in early 1997.

HMC 6015

Table 2.3 Summary of hardware requirements for the simulation tools on PC platforms.

generate results that are compatible with circuit simulation tools. The presentation of the results by the simulation tool itself is covered in a later criteria (see Section 2.2.5). In Table 2-4, we summarize the simulation tools and the interfaces which exist for the tool. We identify the drawing formats which can be imported and/or exported into the simulation tool, as well as the output data file formats for which simulation results can be generated.

Let us first focus on the drawing formats which can be imported and exported. We note that most of the simulation tools can import widely used drawing formats such as GDSII, DXF, and IGES. The simulator EM also has the ability to directly import layout files generated with Libra Series IV software. This is the same software used to generate layouts in Momentum. In addition, EM can also import its geometry files into Libra/Momentum using the same translation program. The simulators SFPMIC+, Micro-Stripes, and Quickwave 3D cannot currently import layouts into their respective geometry editors, although Quickwave 3D and Micro-Stripes are developing import capabilities.

Concerning export capabilities, we note that most tools can export layouts in a number of popular drawing formats. In addition, we note that HFSS has the ability to export directly to lathes and milling machines via the ME-30 format. Currently, Microwave Explorer, Micro-Stripes, Quicksilver, and Quickwave 3D cannot export layouts. However, Micro-Stripes and Quickwave 3D are currently developing layout export capabilities.

Lastly, let us discuss the output data formats which can be generated by the simulation tool. Most of the simulation tools can export results as S-parameters compatible with Touchstone/Libra/MDS and SuperCompact circuit simulation tools. A fair number can also export equivalent R, L, and C netlists for inclusion in SPICE simulations. At present time, it appears MAFIA can only output ASCII text files of S-parameters. Unfortunately, ASCII files are not directly compatible with circuit simulation programs. Lastly, Quicksilver has the ability to import Libra/Touchstone formatted S-parameter data files into its post processor and display these results along with its simulation.

CAD Interface			
2.5D Simulators	Input Geometry Format	Output Results Format	Output Geometry Layouts
EM	GDSII, DXF, Libra (Layout)	Libra/Touchstone, SuperCompact, SPICE	GDSII, DXF
IE3D	GDSII, DXF, Gerber	Libra/Touchstone, SPICE	GDSII, DXF, Gerber (1)
Maxwell Strata	GDSII, DXF	Libra/Touchstone/MDS, SuperCompact	DXF
Microwave Explorer	GDSII	SuperCompact, Harmonica, Libra/Touchstone	none
Momentum	GDSII, IGES, HPGL	Libra/Touchstone/MDS, SuperCompact, SPICE	HPGL, GDSII, IGES, DXF, Gerber, Aristomat
SFPMIC+	none	Libra/Touchstone	HPGL, DXF, IGES
3D Simulators	Input Geometry Format	Output Results Format	Output Geometry Layouts
HFSS	HP ME-30, Unigraphics	Libra/Touchstone/MDS, SuperCompact	ME-30
MAFIA	ACIS, IGES, STL	ASCII	STL, SLA
Maxwell Eminence	GDSII, DXF, Gerber (2)	Libra/Touchstone, SuperCompact, SPICE	DXF
Micro-Stripes	GDSII, DXF, IGES (3)	Libra/Touchstone	GDSII, DXF, IGES (3)
Quicksilver	ACIS, DXF	SuperCompact, Libra/Touchstone (4)	none
Quickwave 3D	none (5)	SPICE, GASSIM, Libra/Touchstone	none (5)

Notes

1. Translator program can also convert any of these three formats to any of the remaining two formats. HMC 6016
2. Import software only available for Sun SPARC and HP 700 series computers.
3. Import/export capabilities available in a future software release.
4. Quicksilver can also import S-parameter data files and display them along with simulation results.
5. Developers will create translators based upon a request from the user.

Table 2.4 Summary of CAD interfaces for import/export of design layouts and export of results for the simulation tools.

2.2.3 Mesh Generation and Limitations

The third performance criteria we have developed addresses the discretization scheme used by the simulation tool, some features of the mesh generator, and any limitations on problem size or definition imposed by the simulator. A summary of this criteria is presented in Table 2-5. The first feature we have identified in this table is the adaptive meshing technique. In adaptive meshing, the simulation engine solves for the fields or currents in the problem, determines where the mesh needs to be refined, and then recomputes the solution. In this manner, the user is guaranteed the mesh is finer in the areas of high activity, and coarser in areas of lower activity. The second feature we have identified is whether or not the mesh is user-definable. All of the simulators have automatic mesh generators, but the ability to allow the user define the mesh is very useful, especially when benchmarking the simulator. The third feature we have identified (for 2.5D simulators only) is the ability to model finite metal thickness. 3D simulators can inherently model finite metal thickness, whereas 2.5D simulators usually assume all metal layers are infinitely thin. Therefore, we have identified which 2.5D simulation tools can also model finite metal thickness. Finally, we list any inherent limitations imposed by the simulator.

Returning to Table 2-5, let us first focus on the 2.5D simulation tools. We first note that most of the 2.5D simulation tools use a combination of triangles and rectangles for defining their mesh. Although EM uses rectangles to define its mesh, triangular elements are available for diagonal traces. However, the user must select these triangular elements, since the default meshing structure is a rectangle, even for diagonal traces. Maxwell Strata, on the other hand, relies exclusively on triangular meshing techniques. In addition, Strata utilizes adaptive meshing techniques to automatically refine its mesh. However, Strata does not allow the user to define the mesh, whereas the remaining simulators do allow the user to define and control the mesh.

Concerning finite metal thickness, Maxwell Strata and IE3D allow for the inclusion of finite-thickness metals in their simulations. Thick metals can be simulated with other 2.5D tools by drawing two metal layers and then connecting them with vias. However, the ability to model thick metal directly is potentially a very nice feature.

Lastly, concerning limitations for the 2.5D simulators, we note that a few of the simulators

Meshing Techniques/Limitations					
2.5D Simulators	Mesh Type	Adaptive Meshing ?	Used Defined Mesh?	Metal Thickness?	Limitations
EM	Rectangles (1)	no	YES	no	none
IE3D	Rectangles, Triangles	no	YES	YES	1000 unknowns (2)
Maxwell Strata	Triangles	YES	no	YES	none
Microwave Explorer	Rectangles, Triangles	no	YES	no	none
Momentum	Rectangles, Triangles (1)	no	YES	no	dielectrics less than 0.1um should be avoided
SFPMIC+	Rectangles, Triangles	no	YES	no	6 dielectric layers, 2 metal layers, 4 ports MAX
3D Simulators	Mesh Type	Adaptive Meshing ?	Used Defined Mesh?	Metal Thickness?	Limitations
HFSS	polygons	YES	YES	YES	25 modes per port MAX
MAFIA	polygons	no	YES	YES	64 objects in simulation MAX
Maxwell Eminence	polygons	YES	YES	YES	none
Micro-Stripes	ploygons	no	YES	YES	none
Quicksilver	polygons	no	YES	YES	4 ports MAX for GUI interaction
Quickwave 3D	polygons	no	YES	YES	none

Notes:

1. Also contains special meshing techniques for edges.
2. Windows 3.1/95 supports 1000 unknowns, Windows NT version supports unlimited unknowns.

HMC 6017

Table 2.5 Summary of meshing techniques and limitations for the simulation tools.

do outright list limitations in their literature. Most notably, SFPMIC+ can only handle up to 6 dielectric layers, 2 metal layers, and 4 ports. This limitation is severe for some applications of highly integrated MMICs. For example, MMIC processes with 3 to 5 metal layers are quite common. Therefore, SFPMIC+ cannot simulate circuits designed with these multi-level metal processes. Concerning IE3D, the advertized version for Windows 3.1 can only handle 1000 unknowns. However, it is possible to use the Windows NT version (which supports unlimited unknowns) on the Windows 3.1 platform. Finally, Momentum cautions against substrates which are thinner than 0.1 μm . Unfortunately, this lower limit is on the order of the distance used in GaAs MMIC processes for MIM capacitor fabrication. Therefore, Momentum may not be appropriate for designers working with certain GaAs processes.

Returning to the 3D simulation tools, we note that they all rely on three-dimensional polygons for their meshing element. Both HFSS and Eminence offer adaptive meshing capabilities to a user-specified level of accuracy, and all simulators allow for the user to define the mesh size, if desired. Concerning the limitations, HFSS allows for up to 25 incident modes at each port. MAFIA specifies a maximum number of 64 different materials in the interior of the problem space. Although this is probably not too restrictive, it is possible to imagine a multi-chip module with more than 64 different materials. Finally, the graphical editor in Quicksilver can only handle up to 4 ports in the layout with its point-and-click GUI interface, although it is possible to define the ports by editing the text description of the layout. This limitation, however, is only relevant to the layout editor and not the simulation engine.

2.2.4 Optimization

Optimization is a rather new, yet very powerful addition to electromagnetic simulation. The fourth performance criteria identifies the simulators with optimization capabilities. In general, the optimization routine modifies the layout of the circuit to match a given set of goals, which can be described as a desired set S parameters, or a minimum difference between simulated results and measurements, for example. The technique of optimization is currently used by many circuit simulators to optimize the circuit components in a schematic. In Table 2-6, we list the simulators which have optimization capabilities. As noted in the table, optimization capabilities are available for

Optimization

2.5D Simulators	Optimization Capabilities ?	Optimization Developer	Software Package(s)
EM	YES	OSA	EMpipe, EMpipe Express, EMpath (1) included with IE3D
IE3D	YES	Zeland	
Maxwell Strata	no (3)		
Microwave Explorer	no (3)		
Momentum	no		
SFPMIC+	YES	Jansen	included with SFPMIC+

3D Simulators	Optimization Capabilities ?	Optimization Developer	Software Package(s)
HFSS	YES	OSA	EMpipe 3D
MAFIA	no		
Maxwell Eminence	YES	OSA	EMpipe 3D
Micro-Stripes	no		
Quicksilver	no (2)		
Quickwave 3D	no (3)		

Notes:

HMC 6018

1. EMpipe Express is a smaller version of EMpipe.
EMpath is tradename of EMpipe Express marketed by Sonnet.
2. A 1-D optimization routine is available, but it requires substantial user definition.
3. An optimization utility is planned in future releases.

Table 2.6 Summary of optimization capabilities for the simulation tools.

EM, IE3D, SFPMIC+, HFSS, and Maxwell Eminence. In addition, Quicksilver offers a one-dimensional optimization routine, but it requires substantial user input to set up the problem. The optimization routines for EM, HFSS, and Maxwell Eminence were developed by Optimization Systems Associates (OSA) [14], and these routines are available as software add-ons to the original simulation package. The software developed by OSA works directly with the particular engine (EM, HFSS, or Eminence), and modifies the geometry of the problem to achieve the specific goal. As a result, most of the computational power is embedded in the simulation engine and not the optimization software. Therefore, the optimization software requires much less RAM and hard disk space as compared to the engine. Concerning IE3D, the optimization routines are included with the electromagnetic software.

The optimization method used by SFPMIC+ is slightly different than the others. This optimization routine relies heavily on a look-up table of basic elements to determine the optimal configuration. While this method is not as powerful as directly operating on the layout, it can give a first approximation to the final layout without performing multiple simulations.

2.2.5 Presentation of Results

The fifth criteria we developed addresses the manner in which the simulators compute and display their results. We summarize the forms of output for each simulator in Table 2-7. We note that with very few exceptions, most of the software packages come with integrated routines to view the output S-parameters, fields, currents, and antenna/far field radiation patterns. In fact, EM is the only simulator in our evaluation which cannot directly display the S-parameters. Similarly, Quicksilver, requires the use of the commercial software package such as IDL to visualize fields, currents, and antenna patterns.

2.2.6 Customer Support

The sixth performance criteria addresses the interface between the user and the software tool. Although the ability of the software tool to model a specific problem is the primary concern, the interface between the software and the user is a significant concern. By nature, electromagnetic

Presentation of Results			
2.5D Simulators	Display of S-parameters	Display of Fields/Currents	Display of Antenna Patterns
EM	<i>text only</i>	<i>optional</i>	<i>optional</i>
IE3D	integrated	integrated	integrated
Maxwell Strata	integrated	integrated	integrated
Microwave Explorer	integrated	integrated	integrated
Momentum	integrated	<i>optional</i>	integrated
SFPMIC+	integrated	integrated	none
3D Simulators	Display of S-parameters	Display of Fields/Currents	Display of Antenna Patterns
HFSS	integrated	integrated	integrated
MAFIA	integrated	integrated	integrated
Maxwell Eminence	integrated	integrated	integrated
Micro-Stripes	integrated	integrated	integrated
Quicksilver	integrated	integrated (1)	integrated (1)
Quickwave 3D	integrated	integrated	integrated

Notes:

HMC 6019

- 1) Quicksilver requires a commercial software package, such as IDL, to display results.

Table 2.7 Summary of presentation capabilities for the simulation tools.

simulation tools are quite complex, and most circuit designers do not have a complete background in computational electromagnetics. In Table 2-8, we identify the types of customer support offered by each software developer. In this table, we have identified which simulators offer support agreements, on-line help, and hands-on training sessions. We note that all of the software developers except Quicksilver offer yearly support contracts, most of which include software upgrades. The support contracts typically include technical help by phone, fax, or e-mail. Additionally, all of the developers offer some form of hands-on training courses for both new and experienced users. However, only a few of the tools utilize on-line documentation (although they all provide a set of manuals in hard copy).

2.2.7 Unique Features

In this section, we discuss the unique features of each simulation tool which are not directly covered by the other six performance criteria. We discuss the unique features for separately for each simulator in the following sections (in no particular order).

2.2.7.1 EM (Sonnet Software)

Sonnet has just released its latest version of EM, which contains a series of new features. First, EM now allows the use of dielectric bricks, where the dielectric parameters can be varied in all three dimensions. Thus, EM can now model planar truncated capacitors, substrate gaps, and dielectric resonators, which is more in the realm of three-dimensional simulators. Secondly, EM now allows the de-embedding of internal ports. EM is the first simulation tool to allow this de-embedding of internal ports. Third, EM allows for frequency-dependent loss in the substrate, which is important for circuits fabricated on silicon.

2.2.7.2 IE3D (Zeland Software)

IE3D, though primarily considered a 2.5D simulation tool, also has the ability to model three-dimensional structures such as circular coaxial cables, spheres, donuts, and helix spirals. Also, with the optional CAD translator, IE3D can convert between popular graphics formats such as GDSII,

Customer Support			
2.5D Simulators	Support Contract?	On-line help?	Hands-on training?
EM	yearly	no	YES
IE3D	yearly	YES	YES (1)
Maxwell Strata	yearly	YES	YES
Microwave Explorer	yearly	no	YES
Momentum	yearly	YES	YES
SFPMIC+	yearly	YES	YES
3D Simulators	Support Contract?	On-line help?	Hands-on training?
HFSS	yearly	YES	YES
MAFIA	yearly	YES	YES
Maxwell Eminence	yearly	YES	YES
Micro-Stripes	yearly	no	YES
Quicksilver	no	YES	YES
Quickwave 3D	yearly	YES (2)	YES

Notes:

1. Available in Spring, 1997.
2. Available in a future release.

HMC 6020

Table 2.8 Summary of customer support options for the simulation tools.

DXF, and Gerber. Third, IE3D can also simulate both open and closed environments, thereby allowing the effect of the package to be considered.

2.2.7.3 Maxwell Strata (Ansoft)

Strata is a fairly new simulation package that was first introduced in late 1995. Strata includes many features, one of which is a fast-frequency sweep. This technique, known as asymptotic waveform analysis, generates an approximate broadband response based on a few frequency measurements. This technique allows the user to identify sharp resonances and localized behavior quickly, without the need for a very fine frequency step. Secondly, Strata uses an advanced matrix solver to generate the solution which is much faster than standard Gaussian elimination methods. Lastly, Strata allows for arbitrary-directed currents in all metal traces, even in vertical traces.

2.2.7.4 Microwave Explorer (Compact Software)

One of the most significant features of Explorer is its ability to perform as a stand alone product or integrated into Compact's suite of simulation software. This integration allows the results from Explorer to easily integrate into Compact's linear circuit and harmonic balance simulators. Also, the latest version of Explorer allows the user to analyze both open and packaged environments. This flexibility allows the designer to investigate the differences between on-wafer and packaged performance. Also, Explorer has added advanced patch antenna simulation capabilities.

2.2.7.5 Momentum (Hewlett-Packard)

Similar to Explorer, Momentum has the added feature of being either a stand alone product, or part of an integrated simulation package such as Libra or MDS. The latest version of Momentum includes a new adaptive frequency sampling scheme that automatically selects the frequency points to provide high resolution at critical frequency points, such as resonances. Second, Momentum now has an improved meshing scheme for metal edges, which can more accurately model the current at the edge. Third, Momentum can now simulate with internal ports connected anywhere in the circuit. Finally, Momentum can now generate far field plots for microstrip patch antennas.

2.2.7.6 SFPMIC+ (Jansen Microwave)

SFPMIC+ is another simulation tool that is integrated with a full simulation suite known as LINMIC+. In addition to modeling arbitrary structures, LINMIC+ contains a look-up table for many common MIC and MMIC structures. These look-up tables allow for the simulation of structures an order of magnitude faster than a full electromagnetic simulation. This technique, though it does not include the parasitic coupling between circuit elements, can be used to test a starting point of a design in a short amount of time. In addition, the look-up tables can also be used for optimization, thus automatically sizing the inductors, capacitors, etc. in the layout, which can then be exported in a format compatible with CAD software.

2.2.7.7 HFSS (Hewlett-Packard)

HFSS, like Momentum, can act as a stand alone simulation tool, or as part of Hewlett-Packard's larger suite of microwave simulation software. One of the key features of HFSS is its ability to pass geometry information directly to lathes and milling machines using the ME-30 connection protocol. The latest version of HFSS has significant improvements in memory usage and temporary file requirements as compared to earlier versions. In addition, HFSS can generate animated field plots, showing the fields in a plane over time. Also, HFSS can now plot dispersion curves of alpha or beta (the propagation factor) versus frequency. Finally, HFSS can now account for all material losses, including metal, dielectric, and magnetic.

2.2.7.8 MAFIA (CST)

MAFIA, in addition to being a true 3D simulation tool, has the ability to model rotationally symmetric structures as 2D problems, thus decreasing the solution time. In addition, MAFIA allows for a variety of excitation sources and signal forms. MAFIA also has the ability to model charged particles and devices such as electron guns, magnetrons, etc. Finally, MAFIA is a time-domain based code, so it can generate a broadband simulation in a relatively short amount of time as compared to frequency-domain solvers.

2.2.7.9 Maxwell Eminence (Ansoft)

One of the main features of Eminence, like Strata, is its ability to perform fast frequency sweeps using the asymptotic waveform analysis. Therefore, resonances and other types of frequency characteristics can be found without a fine frequency sweep. In addition, Eminence uses a high-order absorbing boundary condition (ABC) for the modeling of open environments. The use of ABC's allow the user to place boundaries very close to the radiating structure, thus decreasing the computation time. Third, Eminence allows the use of voltage and current gap sources to model the radiating structures in printed circuit boards and other systems.

2.2.7.10 Micro-Stripes (KCC)

Micro-Stripes, similar to other time-domain solvers, can generate a broadband solution using a fraction of the computer resources required by frequency-domain techniques such as finite-elements. As a result, Micro-Stripes has a very fast computation time, and the computer memory requirements scale linearly with the number of nodes (finite-element based methods scale with the square or cube of the number of nodes). This feature allows large problems to be handled by modest computers. Also, Micro-Stripes has an intelligent algorithm to remove "dead space" from the simulation, where dead space is defined as the interior of conductors. This also reduces the computer resources required to solve the problem. Finally, Micro-Stripes can recognize symmetry in problem descriptions to further reduce simulation times.

2.2.7.11 Quicksilver (Sandia National Laboratory)

Quicksilver is another simulation tool that uses time domain techniques, and as a consequence the solution time scales linearly with the number of unknowns. Also, Quicksilver can generate a broadband response in a relatively short amount of time from a single simulation. Third, Quicksilver has the ability to run on parallel systems, thus improving the solution speed. Fourth, Quicksilver relies on advanced commercial software for its post processing, which allows the developers to concentrate on the engine, while leaving development of the graphics capabilities to experts in that field. Lastly, Quicksilver has the ability to account for charged particles in the simulation, which allows microwave

sources to be included in the simulation domain.

2.2.7.12 Quickwave 3D (Warsaw University)

Quickwave 3D, another of the time-domain simulators, is truly a platform independent simulation tool. The developers of Quickwave 3D use object-oriented C++ programming along with ZAPP programming tools of Roguewave to implement the simulation tool on a variety of UNIX and PC hosts. Also, Quickwave 3D uses partitioning schemes to break the problem down into a series of smaller problems that are connected by the fields on their boundaries. Partitioning is a very efficient method of solving large problems, since each of the partitions require much less memory and simulate faster than the entire problem. Third, Quickwave 3D is designed for use on parallel computing systems. Finally, Quickwave 3D incorporates local integral approximations to account for irregular geometries, which is a much faster technique than user a very fine or highly non-uniform grid.

2.3 Final Comments on the Performance Criteria

One area we did not address with our performance criteria is the cost of each of the simulation packages. While cost is certainly an issue with any piece of software (and simulation software is expensive, in general), the cost of electromagnetic simulation software should be judged against its need and its potential benefit. This type of judgement will be unique to each designer, and therefore we offer no comparison of the different tools based upon their purchase price.

3.0 SIMULATOR BENCHMARKING

The second part of our research effort focused on the computational benchmarking of electromagnetic simulation software. Benchmarking, in general, involves the simulation of various test structures followed by a comparison to measured data, analytical data, or simulation results generated from other software. In addition, factors such as simulation time are also considered in benchmarking studies, since the time required to reach a solution is just as important as the solution itself. The goal of benchmarking is often a determination of the “best” simulation tool, where “best” is defined by the user. However, benchmarking of electromagnetic software is highly dependent on a number of factors, including the type of problem being solved and the experience of the user with regards to the simulation tool. As a result, benchmarking studies must be constructed very carefully to address a wide variety of issues, since a narrow scope may not fully demonstrate the strengths or weaknesses of a particular simulator. Therefore, the work discussed in this section is not intended to determine which electromagnetic simulation tool is “best”. Rather, the work is presented here to offer a designer a view of some benchmarking studies and techniques for creating their own.

A very informative overview on electromagnetic simulator benchmarking has been published by Sonnet Software [15]. This handbook, entitled “Evaluation of Electromagnetic Microwave Software” outlines a series of benchmarks, their corresponding error definitions, procedures for setting up the simulations, and outlines for data collection. In addition, the document goes into further detail behind the philosophy of benchmarking and how it is best applied to electromagnetic software. Although the structures discussed in this publication are characteristic of microwave integrated circuits and MMICs, the benchmarking methodology is applicable to all areas of electromagnetic simulation. This document is a great tool for any designer who wishes to perform their own evaluation of different software packages, and it is available through Sonnet Software.

For this research effort, we did not attempt any benchmarking of the simulation tools ourselves, but rather we researched material that has been published in forums available to the interested public. During the course of our research, we found two very informative sources of electromagnetic benchmark studies. One source was the journal *Microwave Engineering Europe* (MEE) [16, 17], which published two articles comparing 2.5D simulation tools and 3D simulation

tools. These studies have been praised by the various software companies involved in the benchmarking. Our second source was the *International Journal of Microwave and Millimeter-Wave Computer-Aided Engineering* (MMWCAE) [18-37], a scientific journal which publishes a series column entitled "MIC Simulation Column". This column is dedicated to the comparison of electromagnetic simulation tools. In addition, this journal also publishes a large number of articles of general interest to designers who utilize electromagnetic simulation.

In the next two sections, we report on the benchmarking studies published by these two journals. The goal is to summarize this benchmarking information in a single publication, and offer the designer some examples of benchmarking structures to try for themselves.

3.1 MEE Benchmarks

In this section, we first discuss the benchmarking of electromagnetic simulators published in the November, 1994 and May, 1995 issues of *Microwave Engineering Europe* [16, 17]. All of the information presented in this section was originally published in the two referenced issues. In the interest of brevity, the information will not be cited with each occurrence. However, the reader can correctly assume that all tables and graphs in this section are generated from data published in the two cited references. To begin, Table 3-1 lists the benchmarking examples published in these two articles. Benchmark 1 was a zero length line, benchmark 2 was a 45 degree phase shifter, benchmark 3 was a meandered thru line, and benchmark 4 was a waveguide power splitter. We note that the 2.5D simulators EM (Sonnet Software), Momentum (Hewlett-Packard), and Microwave Explorer (Compact Software) evaluated benchmarks 1, 2 and 3, whereas the 3D simulators Microwave Lab (MacNeal-Schwendler), Micro-Stripes (KCC) and MAFIA (CST) evaluated benchmark 4. In addition, MAFIA also evaluated benchmarks 2 and 3.

Comparisons of Benchmarks 1 through 4 are presented in Figures 3-1 through 3-4, respectively. In Figures 3-1a and 3-1b, we first present the simulations of Benchmark 1, the zero-length line. This structure was simply a two-port microstrip line with coincident reference planes in the middle of the line. The ideal responses for this benchmark are $|S_{11}| = -\infty$ (dB) and Phase $S_{21} = 0$ deg. We note that in Figure 3-1a, EM gives the best result for $|S_{11}|$, whereas Momentum and

**Microwave Engineering Europe
Benchmark Study**

Benchmark	Type	Simulators Evaluated
1. Thru Line, zero-length	2.5D	EM (Sonnet Software) Momentum (Hewlett-Packard) Microwave Explorer (Compact Software)
2. 45 degree Phase Bridge	2.5D	EM (Sonnet Software) Momentum (Hewlett-Packard) Microwave Explorer (Compact Software) MAFIA (CST - Computer Simulation Technology)
3. Meander Thru Line	2.5D	EM (Sonnet Software) Momentum (Hewlett-Packard) Microwave Explorer (Compact Software) MAFIA (CST - Computer Simulation Technology)
4. Waveguide Spiltter	3D	Microwave Lab (MacNeal-Schwendler) Micro-Stripes (KCC - Kimberly Communications Consultants) MAFIA (CST - Computer Simulation Technology)

HMC 6021

Table 3.1 Description of the benchmarks and the respondents published in *Microwave Engineering Europe*.

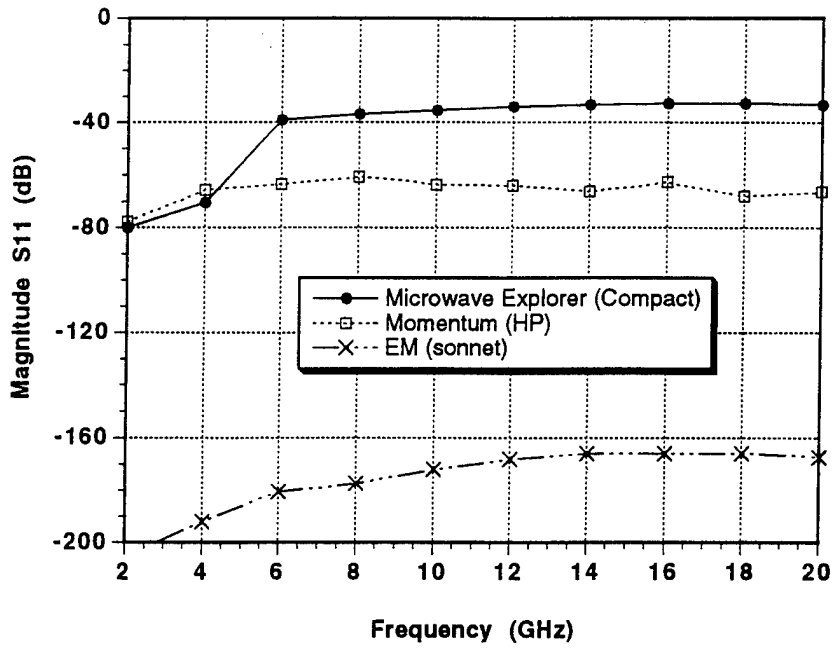

HMC 6024

Figure 3.1a Comparison of |S11| for Benchmark 1, the zero-length time.

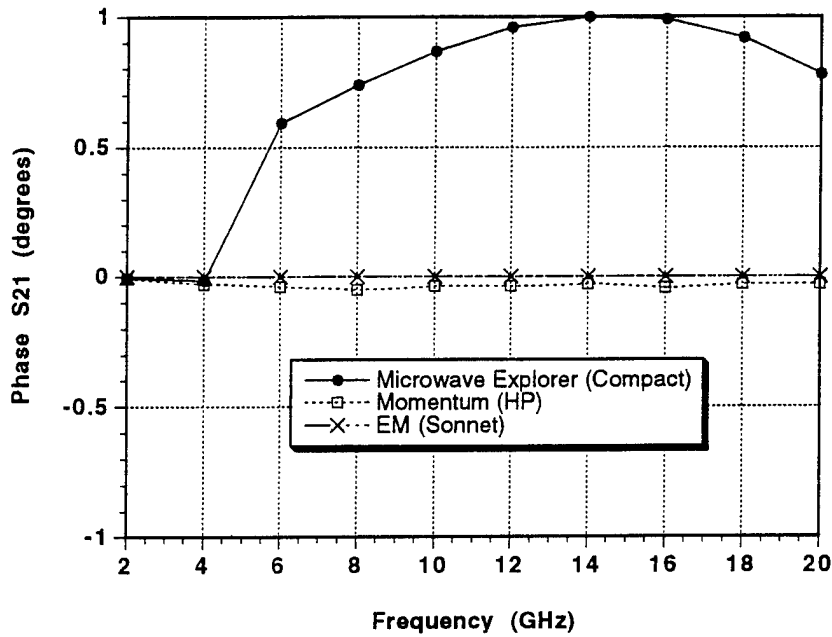

HMC 6025

Figure 3.1b Comparison of the phase of S21 for Benchmark 1, the zero-length time.

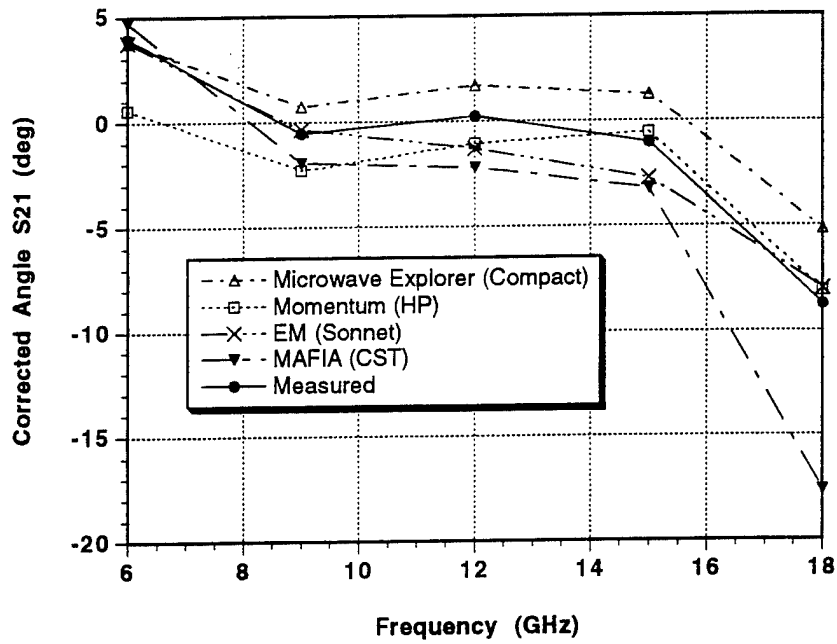

HMC 6026

Figure 3-2a. Comparison of the corrected phase of S21 for Benchmark 2, the 45° phase bridge.

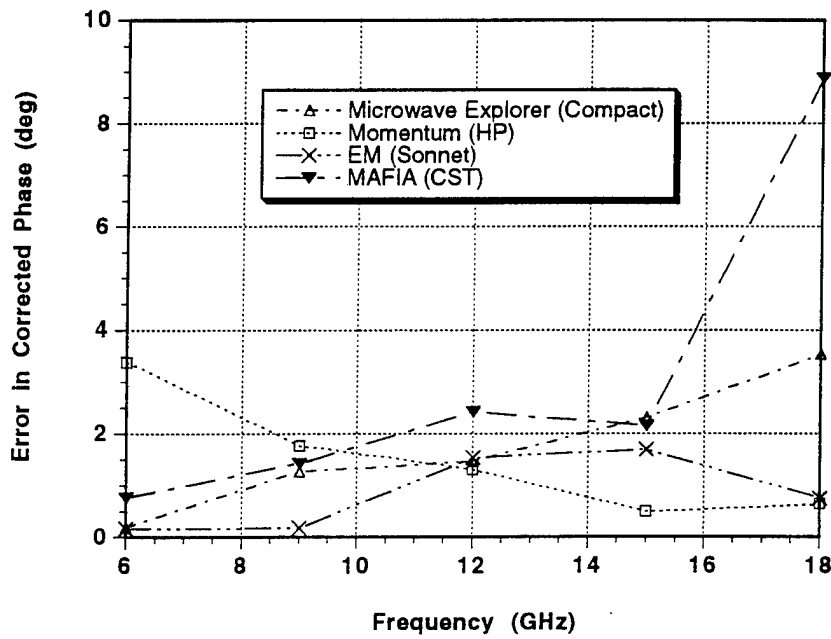

HMC 6027

Figure 3-2b. Comparison of the error in the corrected phase of S21 (b) for benchmark 2, the 45° phase bridge.

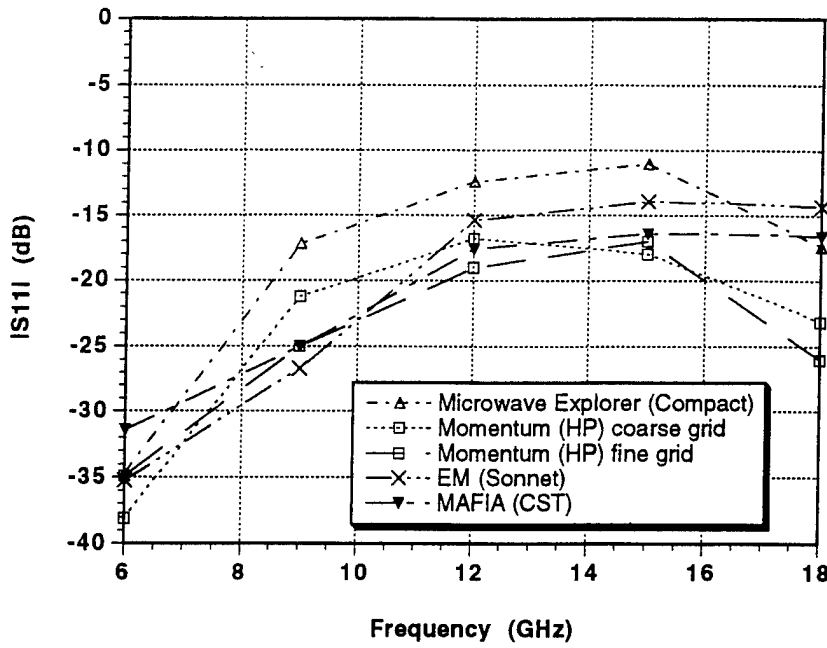

HMC 6028

Figure 3-3a. Comparison of |S11| for Benchmark 3, the meandered line.

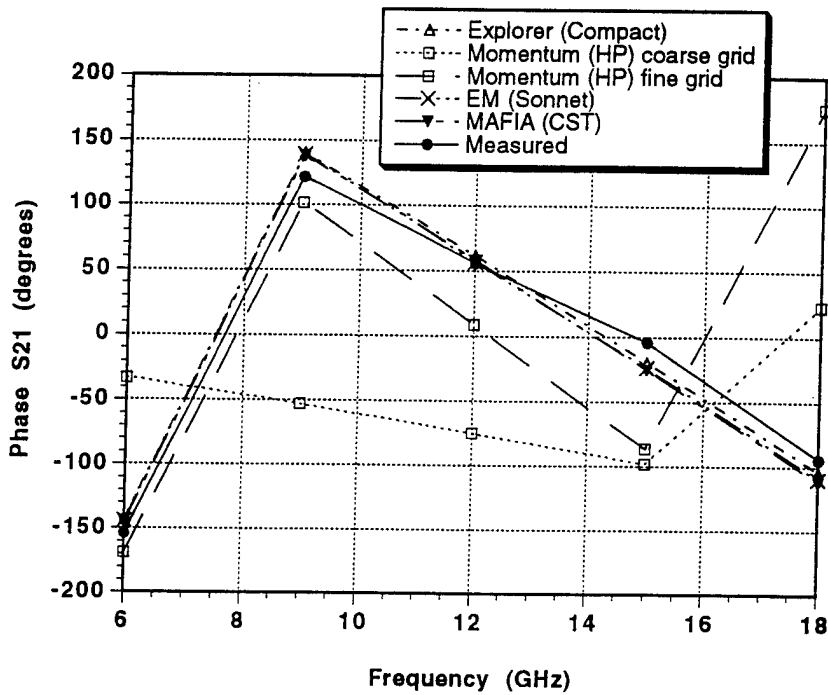

HMC 6029

Figure 3-3b. Comparison of the phase of S21 for Benchmark 3, the meandered line.

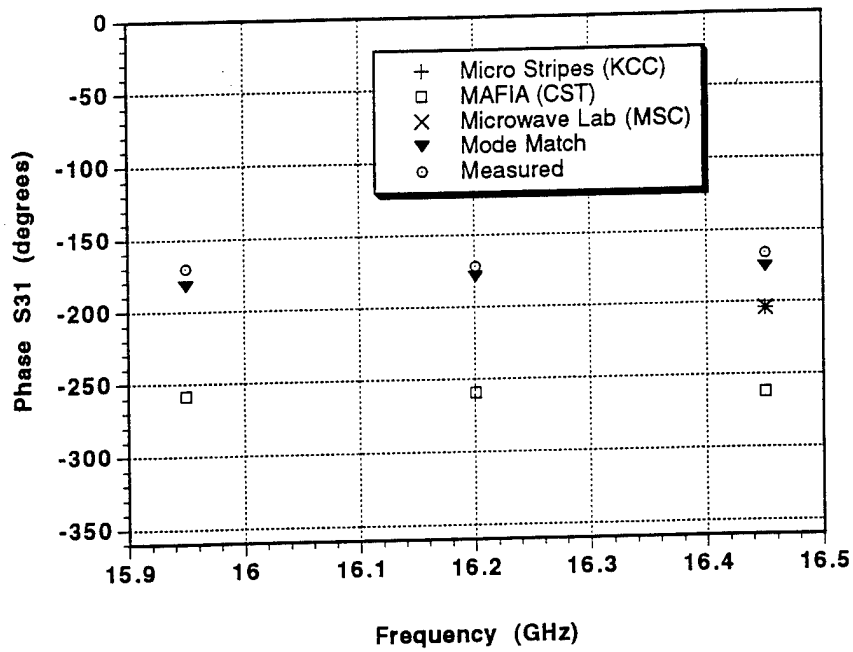

HMC 6030

Figure 3-4a. Comparison of the phase of S31 for Benchmark 4, the waveguide splitter.

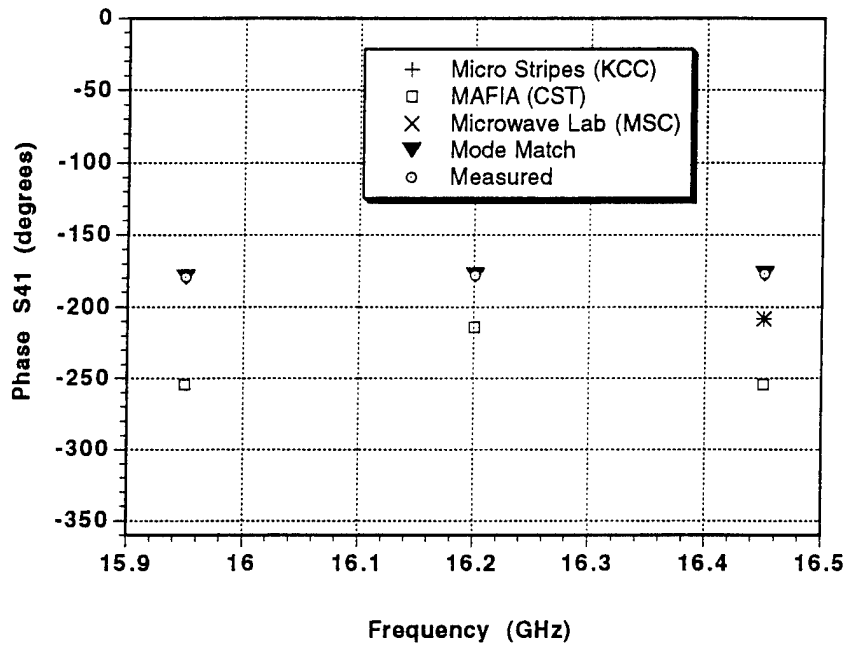

HMC 6031

Figure 3-4b. Comparison of the phase of S41 for Benchmark 4, the waveguide splitter.

Explorer are somewhat limited in their dynamic range. For the Phase S21 shown in Figure 3-1b, both EM and Momentum give very good results, whereas Explorer is in error up to 1 deg. This type of phase error would not be acceptable where phase is a critical parameter, such as image-reject mixers or phase-frequency detectors.

In Figure 3-2a and 3-2b, we next present the simulations and measurements of Benchmark 2, the 45° phase bridge. This circuit was designed to give a 45° phase shift over the band 6-18 GHz. In Figure 3-2a, we compare the simulations of the phase shift to the measured results, whereas in Figure 3-2b we present the absolute error in the phase shift simulations. This error is defined as:

$$\text{Error} = |\Delta \Phi_{\text{measured}} - \Delta \Phi_{\text{simulated}}| \quad (1)$$

We note that all of the simulation tools model this structure reasonably well, although MAFIA has an error of 9 degrees at the highest frequency measured.

In Figures 3-3a and 3-3b, we next compare the simulations Benchmark 3, the meandered line. In Figure 3-3a, we compare the |S11| for this line, whereas in Figure 3-3b we compare the phase of S21. We first note that Hewlett-Packard submitted two Momentum simulations of this structure, one using a coarse grid and the other using a fine grid. We also note that measured data for |S11| was not provided. Concerning |S11| in Figure 3-3a, we note that all simulations are in relatively close agreement. However, as shown in Figure 3-3b, there are large discrepancies in the phase of S21 determined by Momentum. Evidently, the change from a coarse grid to a fine grid led to improvements at lower frequencies, but the high frequency performance of Momentum is much different than the other simulation tools and the measured data. Meanwhile, Explorer, EM, and MAFIA generated nearly identical simulations of the Phase of S21.

Finally, in Figures 3-4a and 3-4b we present the results for Benchmark 4, the waveguide splitter. This was the only three-dimensional structure analyzed in this study, and the 2.5D simulators were not included in this benchmark. In Figure 3-4a, we present the phase comparison of S31, and in Figure 4b we present the phase comparison of S41. We first note that Microwave Lab and Micro-Stripes only reported one discrete frequency response at 16.45 GHz. In addition, we note the results of mode-matching were also included with the commercial simulation results. Mode matching is an analytical technique used to solve for the fields generated by discontinuities in waveguides. Returning to the figures, we can see that the mode matching technique was very close to the measured phase

data, whereas the commercial simulators (especially MAFLA) yielded large errors of up to 100 degrees. In conclusion, this study contained benchmarks with both analytical solutions (benchmark 1) and measured data (benchmarks 2, 3 and 4). The results from these benchmarks underscores the need to test each simulator over a wide variety of problems in order to get an overall indication of performance. After these benchmarking studies were published, the software vendors involved submitted their comments on the study to *Microwave Engineering Europe* [17,38]. The interested reader is encouraged to read these responses.

3.2 MMWCAE Benchmarking

Our second source of benchmarking examples is the *International Journal of Microwave and Millimeter-Wave Computer-Aided Engineering* [18-37]. This journal, published since 1991, contains a series column entitled "MIC Simulation Column" which is devoted to the benchmarking of electromagnetic simulation tools. In the MIC Simulation Column, the layouts of circuits are published and readers are invited to simulate the structure using any circuit or electromagnetic simulator. The responses are then published in both graphical and tabular form in later issues. In Table 3-2, we present a list of the benchmarks published to date in the MIC Simulation Column. This table lists the name of the benchmark, its publication date, the simulation tools used to analyze this structure, and the dates these responses were published. We note that there have been 30 different structures published in the column, although not all of them have been analyzed by a simulation tool. In this section, we focus on a select few structures that were analyzed by at least two different simulation tools and published with tabular data. By means of an optical scanner, we were able to import the published tabular data into a computer and combine the results for each structure on a single graph. However, not every response contained results published in tabular forms, and these responses were subsequently left out of our analysis.

Returning to Table 3-2, we note that some of the respondents utilized electromagnetic simulation tools, while others utilized circuit simulation tools such as Libra, SuperCompact, and Microwave Design System (MDS). A few respondents even reported results obtained with custom software, while fewer still have measured results. We also note that the majority of responses are

Benchmarks

Benchmark	Publish Date	Respondents
Meander line	January 1991	EM, EMSim, Explorer, IE3D, MDS
Hairpin filter	January 1991	EM, EMSim, Explorer, IE3D, MDS
Spiral Inductor	April 1991	custom, EM, Explorer, Linmic+, measured
Low pass filter	July 1991	EM, EMSim, IE3D, Libra
35 GHz bandpass filter	October 1991	EMSim, Libra & PMESH
Meander line - chamfered bends	October 1991	EMSim, Explorer, IE3D, Libra & PMESH
Meander line - curved bends	October 1991	EMSim, Libra & PMESH
Bias network	January 1992	IE3D, Libra
Interdigitated capacitor	April 1992	EM, Explorer, IE3D
Dual radial stub	April 1992	IE3D
Schiffman section topology	July 1992	IE3D, measured
Bandpass filter	January 1993	Explorer, IE3D, SuperCompact
Via holes	January 1993	IE3D
Six port structure	January 1993	IE3D
Amplifier	January 1993	IE3D
Meander line a	April 1993	custom, EM, Explorer, Libra
Meander line b	April 1993	custom, EM, Explorer, Libra
Meander line c	April 1993	custom, EM, Explorer, Libra
Meander line d	April 1993	custom, EM, Explorer, Libra
MMIC matching network	July 1993	IE3D
Lambda/2 resonator	October 1993	Explorer, IE3D
Low pass matching network	January 1994	
Coupled line matching network	January 1994	
Bandpass filter	April 1994	EM, Explorer, IE3D, Libra & Measured, Libra & EM
Stripline standard benchmark	April 1994	EM, HFSS, IE3D, Momentum
Miniature filter	July 1994	EM, IE3D
2-way Wilkinson divider	October 1994	Explorer, IE3D
MMIC matching section	January 1995	Explorer
Coupled lines	January 1995	
MIC bandpass filter	March 1995	IE3D, Libra & EM

HMC 6022

Table 3.2 Description of the benchmarks and their respondents published in the *International Journal of Microwave and Millimeter-Wave Computer-Aided Engineering*.

generated from 2.5D simulation tools, and with the exception of the stripline standard benchmark, no 3D simulation tool has been used to analyze any of these structures. Finally, it does not appear that the electromagnetic simulation tool EMSim is currently available as a commercial product even though it was used to analyze some of the earlier benchmark examples.

One comment we make involves the date of these benchmark publications. Many of the earlier structures have been simulated with software that has been revised and refined numerous times. As a result, the earlier comparisons should be viewed with caution, since they most likely do not represent the performance of the current simulator. However, these earlier simulations do present another circuit example of which can be simulated.

Another comment we make involves a comparison of simulator speed. Although the simulation time and computer platform is reported in the published responses, we made no effort to compile this information. While simulation speed is important, it is unfair to compare simulator speed when different computer platforms are used by different operators. In addition, such critical factors such as the subsection size was often not published in the column. Therefore, we offer no comparison of the different simulation tools based upon their solution speed.

In the next sections, we present comparisons for the select number of benchmarks highlighted in boldface in Table 3-2. Each section is titled with the particular benchmark, followed by the month and year this benchmark was published as a test structure. We would like to acknowledge that all information presented below was originally published in the MIC Simulation Column of the *International Journal of Microwave and Millimeter-Wave Computer-Aided Engineering* [18-37]. In the interest of brevity, we will not reference each individual citation from this column. However, the reader can assume that all data and figures presented and discussed in the sections below were obtained from this column. In the case of the standard stripline benchmark (Section 3.2.1), all conclusions can be attributed to discussions published in MMWCAE [39]. Otherwise, all other conclusions about the benchmarks are drawn by the authors of this report.

3.2.1 Standard Stripline Benchmark (April 1994)

This benchmark was published in the April 1994 issue of MMWCAE, and it is also discussed

in a separate publication [40]. Essentially, this benchmark involves the simulation of a length of zero-thickness stripline with a characteristic impedance of 50 Ohms and a phase shift of 90 degrees at a single frequency (15 GHz in this benchmark study, although the frequency is irrelevant). The unique feature of this benchmark is its exact theoretical solution. Therefore, an error can clearly be defined, thus offering a method of comparing the different simulation tools based upon the defined error. For the stripline standard, the error as been defined as:

$$\text{Error (\%)} = 100 * |S_{11}| + 1.1 * |90 + \text{Ang}(S_{21})| \quad (2)$$

This error represents, to a first order, the error in the equivalent lumped element circuit models of the stripline. This benchmark was developed to examine two properties of a simulation tool: the effect of subsection size on the error, and the effect of subsection size on the solution time.

In Figures 3-5a, 3-5b, and Table 3-3, we present the published results for this benchmark. Let us first consider Figures 3-5a and 3-5b. In the figures, the x-axis represents the solution time, which is directly related to the number of subsections, and the y-axis represents the error as defined in Eq. (2). As noted in the publication of the standard, we can only compare simulation run times which use the same computer platform and the same operator. Therefore, Figure 3-5a compares EM (squares) and Momentum (triangles) for the stripline standard at 15 GHz performed on a SPARC-2 workstation by the same engineer. We note that at a given error level, there is a 1 to 2 order of magnitude difference in execution time between EM and Momentum. One explanation for this difference is that EM uses a two-dimensional fast-Fourier transform to calculate the S-parameters, whereas Momentum uses a four-dimensional numerical integration. Therefore, EM generates a solution for the stripline standard benchmark that is faster than Momentum for a given level of error. However, this result does not imply that EM is always faster than Momentum, but rather only for this particular example simulated on this particular computer platform.

Figure 3-5b presents the error versus solution time for HFSS, the 3-D simulation tool from Hewlett-Packard. Since this data was not generated by the same operator or the same computer as Figure 3-5a, we cannot directly compare Figures 3-5a and 3-5b. Returning to Figure 3-5b, we first note that the error is non-monotonic, for reasons that were not understood at the time of publication. However, we note the analysis time at a given error level is, in general, one order of magnitude greater than EM. This slow solution time, as compared to EM, is due to the volume meshing

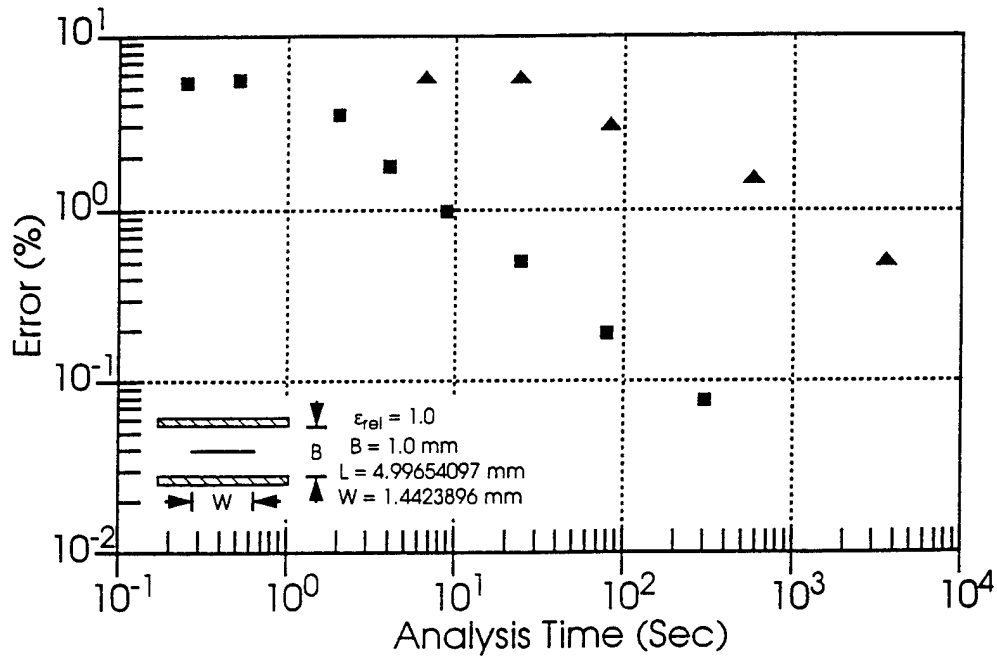

HMC 6032

Figure 3-5a. Comparison of the error vs. simulation time for the stripline standard benchmark between EM (square) and Momentum (triangles).

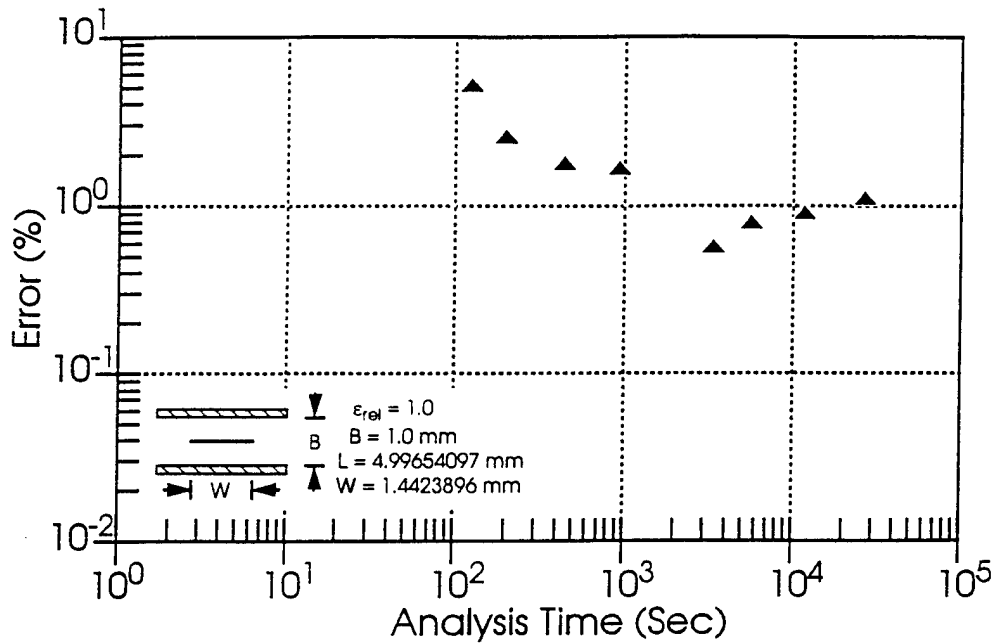

HMC 6033

Figure 3-5b. Error vs. simulation time for the stripline standard benchmark analyzed by HFSS.

IE3D Results			EM Results		
Cells/width	Cells/length	Error (%)	Cells/width	Cells/length	Error (%)
1	3	4.4	1	3	3.5
2	4	5.2	2	4	5.1
4	10	3.6	4	10	3.3
10	31	2.1	10	31	1.5

HMC 6023

Table 3.3 Comparison of the error in the stripline standard benchmark between IE3D and EM.

employed by HFSS, as opposed to surface meshing used by EM. In general, 3D simulation tools such as HFSS will be much slower than 2.5D simulation tools when analyzing planar structures, and as a result 3D tools are not recommended for the simulation of highly integrated planar circuits.

In Table 3-3, we next compare the stripline standard benchmark results for IE3D and EM. These results presented in this table are slightly different than the figures above. The engineer performing the tests did not have complete control of the subsectioning when using IE3D. As a result, the error is not monotonically decreasing with increased number of subsections. This phenomenon was thought to arise from two error sources [39, 41], the error associated separately with cell length and cell width, and underscores the need to fix all but one of the test parameters. However, we can see from these tables that EM generates an error that is slightly less than IE3D. This example did not clearly state if identical computers were used for the analysis. Therefore, we offer no comparison of the simulation times for EM and IE3D.

3.2.2 Spiral Inductor Benchmark (April 1991)

The second benchmark we discuss is the spiral inductor published in April 1991. This structure is one of the few published in the column with measured data. This inductor was fabricated on a GaAs substrate using an airbridged MMIC process. One port of the inductor is connected to a coplanar probe, and the other port is grounded. Thus, this is a one-port test structure. A graphical description of the structure is presented in Figure 3-6. In Figures 3-7a and 3-7b, we present a comparison of the simulation tools to the measured results. We note the custom simulation was developed from expressions for coupled microstrip lines and microstrip bends, and was not developed into a commercial product. Concerning the magnitude of S_{11} in Figure 3-7a, we can see that all of the simulations are reasonably close to one another, with no simulation clearly superior to any of the others. However, we would like to point out that the measured data for $|S_{11}|$ is probably in error at higher frequencies, since the measurement of S_{11} is greater than 0 dB at 20 GHz. This error is most likely due to an error in calibration.

In Figure 3-7b, we see that all simulations generate reasonable results for the Phase of S_{11} , with EM closest to the measured data for low frequencies, and Linmic+ closer at higher frequencies. However, the custom simulation (which was based upon a coupled microstrip model) is consistently

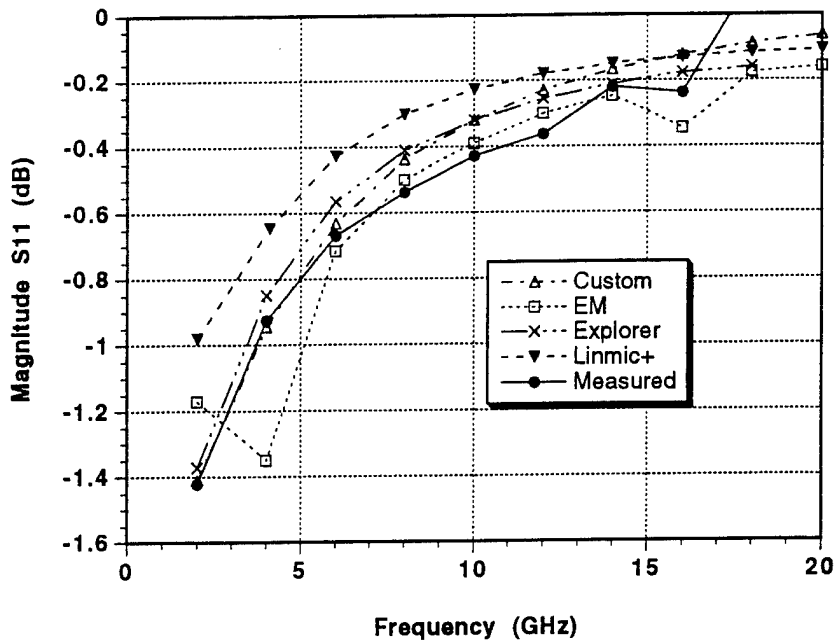

HMC 6035

Figure 3-7a. Comparison of |S11| for the spiral inductor benchmark (April 1991).

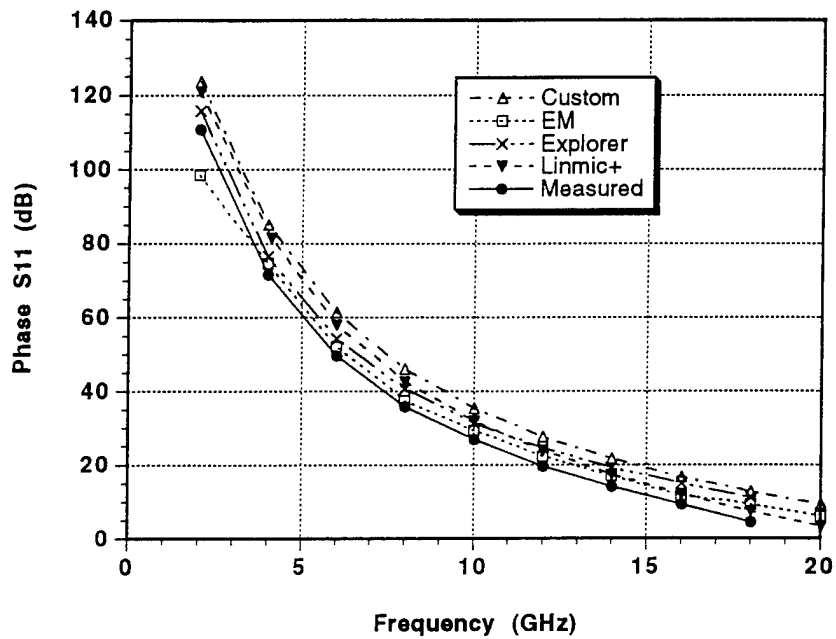

HMC 6036

Figure 3-7b. Comparison of the phase of S11 for the spiral inductor benchmark (April 1991).

off by 10 degrees. Therefore, this benchmark shows the increased accuracy of electromagnetic simulation tools when compared to coupled microstrip models for the simulation of spiral inductors.

3.2.3 Bandpass Filter Network (April 1994)

The next benchmark we discuss is the MMIC bandpass filter published in April 1994. A graphical description of this structure is presented in Figure 3-8. In Figures 3-9a and 3-9b, we present comparison of the $|S_{11}|$ and the phase of S_{11} , respectively, as determined by the simulation tools. We note that this benchmark contains one simulation which combined Libra software with a measurement-based model of the via hole (signified by Libra in the figures), and a second simulation which combined Libra models and EM simulations of the cross- and Tee-junctions (signified by Libra/EM). We first note that in Figure 3-9a, EM and the two Libra-based simulations predict nearly-identical pass bands for the filter, whereas IE3D and Explorer predict higher resonant frequencies. The simulations of $|S_{21}|$ show identical trends in resonant frequency, and thus for brevity this response is not shown. In addition, we note that Explorer predicts a lower Q-factor than any of the other simulations, since the resonance point is not as steep as the other simulations. This result is also supported by the simulation of $|S_{21}|$.

In Figure 3-9b, we note that EM and Explorer predict a smooth transition through resonance, whereas the Libra-based simulations and IE3D show irregular behavior at the resonance point. Without measured data, it is difficult to say which simulation is closer to reality, and whether or not the phase transition through resonance is smooth or irregular. However, we can clearly see that the two Libra models are nearly identical (as they were in Figure 3-9a), which indicates that the addition of the EM models for microstrip junctions in circuit offered no additional benefit. In addition, we can see that the three electromagnetic simulators used in this benchmark generate significantly different responses, which is a cause for concern if the user is attempting to model similar bandpass filter structures without the benefit of measured data. The simulations of the Phase of S_{21} for this structure support the general conclusions presented in Figure 3-9b, and in the interest of brevity this response is not shown.

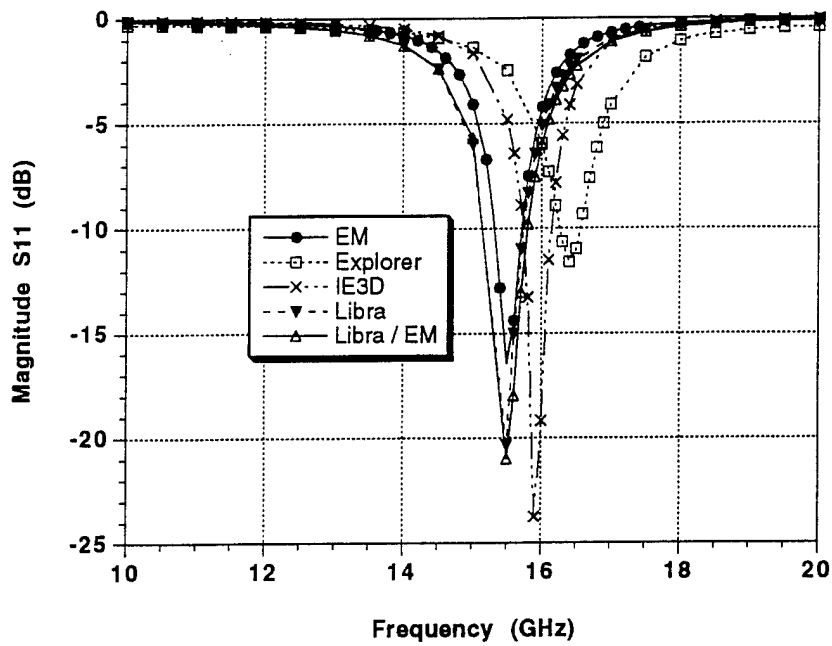

HMC 6038

Figure 3-9a. Comparison of $|S_{11}|$ for the MMIC bandpass filter benchmark (April 1994).

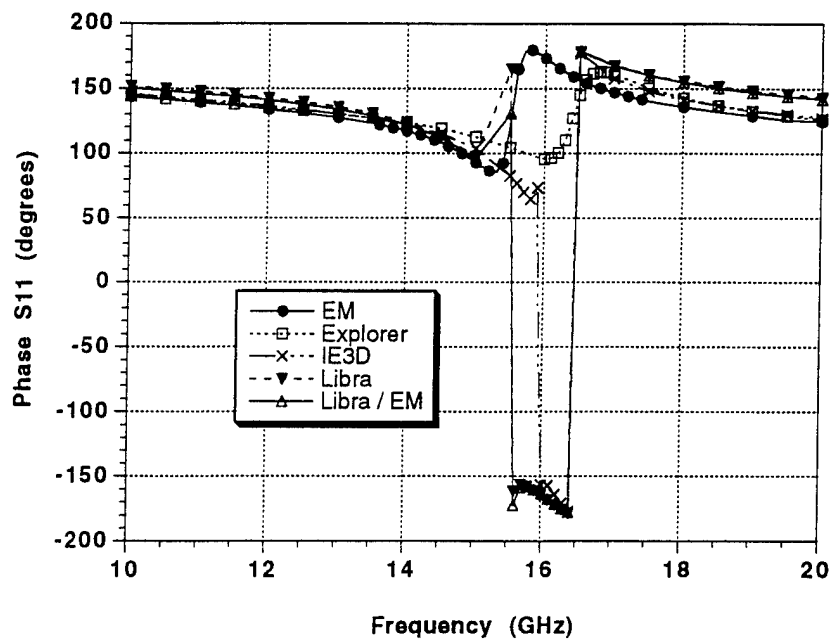

HMC 6039

Figure 3-9b. Comparison of the phase of S_{11} for the MMIC bandpass filter benchmark (April 1994).

3.2.4 MIC Bandpass Filter (March 1995)

The next benchmark we discuss is a second bandpass filter, published in March, 1995. A graphical description of this structure is presented in Figure 3-10. In Figures 3-11a and 3-11b, we present comparison of $|S_{11}|$ and $|S_{21}|$, respectively, as determined by the simulation tools EM, Libra, and IE3D. As noted in these two figures, two EM simulations were performed, one with a coarse grid and the other with a fine grid. The Libra simulation was generated from the analytical model MCFIL, which is a library element included with the simulator. In Figure 3-11a, we first compare the simulations of $|S_{11}|$. We note that the two EM simulations are quite different, indicating that subsection size is important when simulating this structure. In addition, the Libra simulation does not predict a resonance near 15 GHz, whereas the electromagnetic tools predicted a sudden drop-out in $|S_{11}|$ near this frequency. We also note that the Libra simulation predicts less out-of-band rejection when compared to the electromagnetic simulators. These conclusions are also supported by simulated responses for the phase of S_{11} (not shown). In Figure 3-11b, we next compare $|S_{21}|$ for these simulators. We note that IE3D and EM/coarse grid are nearly identical up to about 17 GHz. Again, however, the EM/fine grid is noticeably different than the coarse grid simulation. In addition, the Libra simulation predicts a wider frequency pass band than the electromagnetic simulations. Although not shown, the phase of S_{21} is nearly identical for all of the simulation tools, including Libra.

In conclusion, this benchmark again shows the superiority of electromagnetic based simulation tools over circuit simulators (with analytical models) such as Libra for the simulation of microstrip bandpass filters. However, the variability between the electromagnetic simulators indicates that measured data is required to determine which simulator can accurately model this structure.

3.2.5 Interdigitated Capacitor (April 1992)

The last structure we wish to discuss is the interdigitated capacitor published in April 1992. A graphical description of this benchmark is presented in Figure 3-12. In Figures 3-13a we compare the simulations of $|S_{11}|$ and $|S_{21}|$, whereas in Figure 3-13b we compare the phase of S_{11} and the phase of S_{21} for this structure. Although a simulation of this structure using EM was also published, this data was not available in tabular form and could not be included in our figures. Therefore, we only compare the simulation tools IE3D and Microwave Explorer. In Figure 3-13a, we note that the

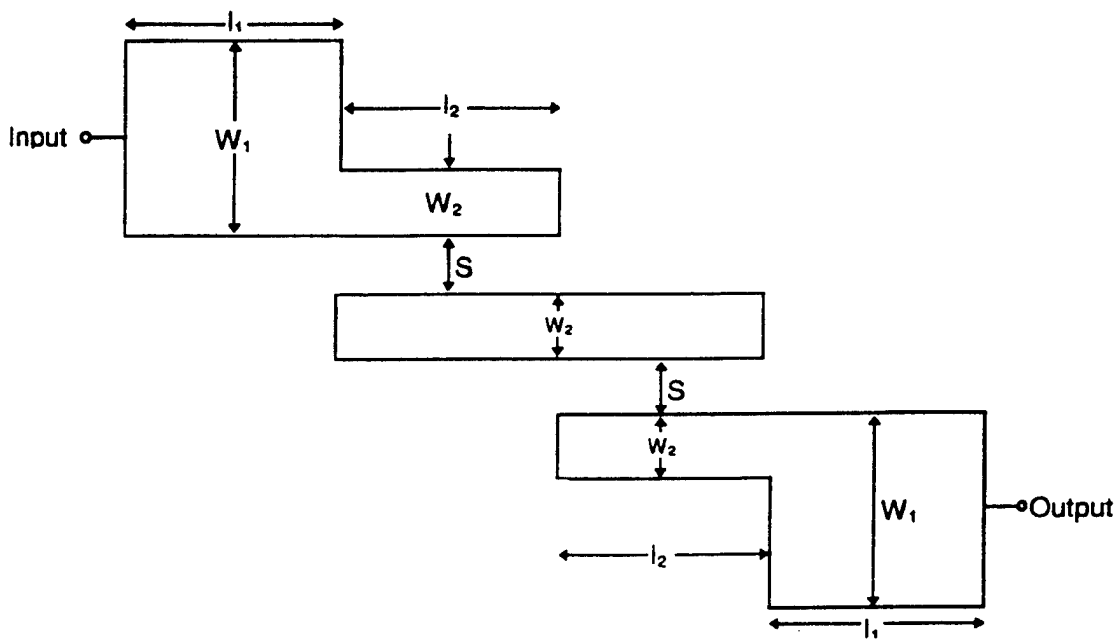

HMC 6040

Figure 3-10. Description of the MIC bandpass filter benchmark originally published in the March 1995 issue of MMWCAE.

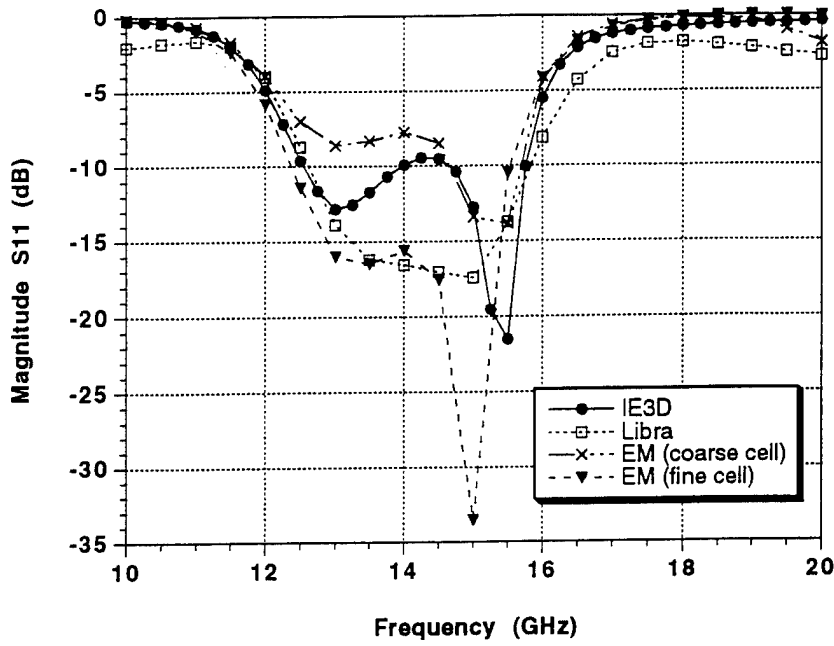

HMC 6041

Figure 3-11a. Comparison of the $|S_{11}|$ for the MIC bandpass filter benchmark (March 1995).

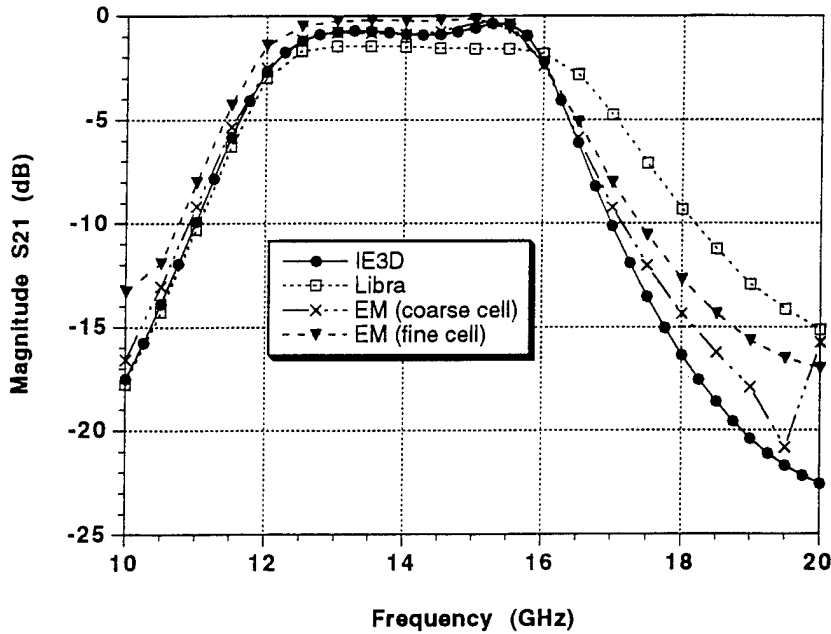

HMC 6042

Figure 3.11b. Comparison of the $|S_{21}|$ for the MIC bandpass filter benchmark (March 1995).

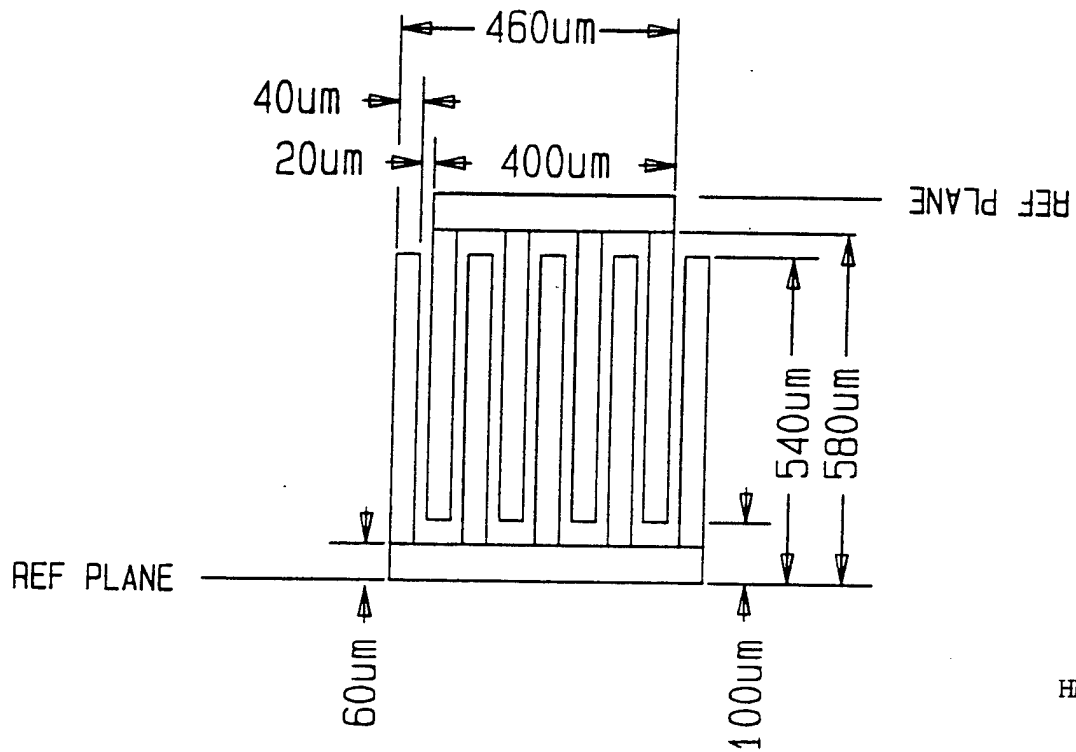

HMC 6043

Figure 3-12. Description of the interdigitated capacitor originally published in the April 1992 issue of MMWCAE.

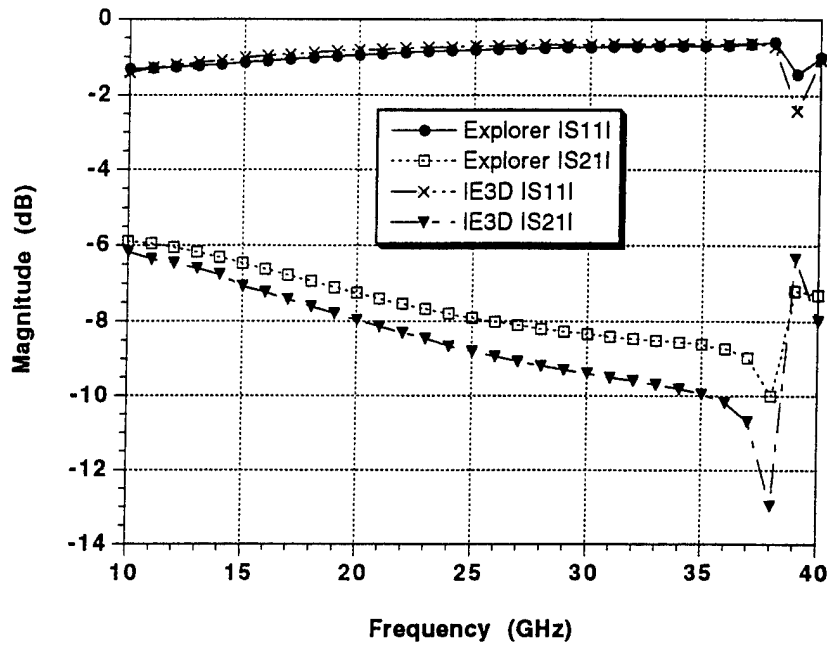

HMC 6044

Figure 3-13a. Comparison of |S11| and |S21| for the interdigitated capacitor benchmark (April 1992).

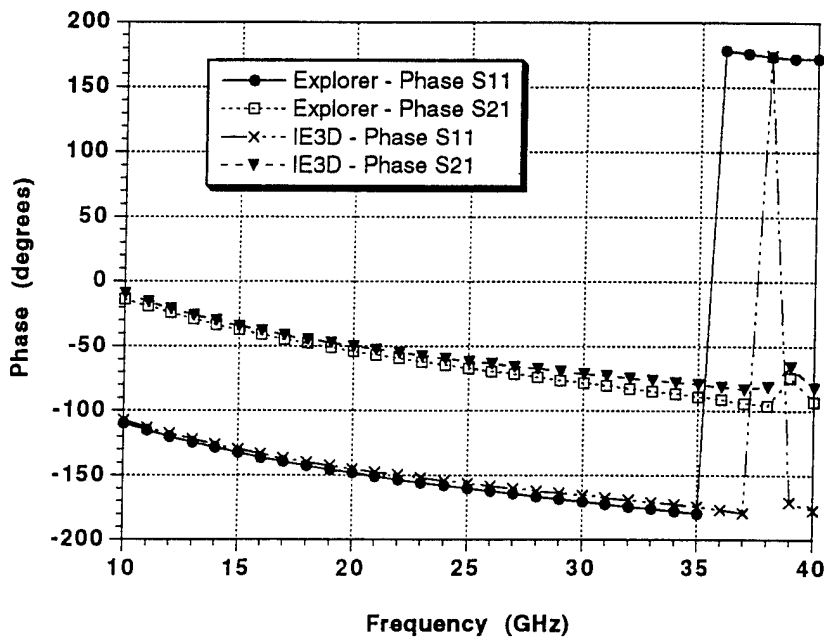

HMC 6045

Figure 3-13b. Comparison of the phase of S11 and the phase of S21 for the interdigitated capacitor benchmark (April 1992).

simulations are nearly identical, although IE3D predicts a sharper resonance near 39 GHz. In Figure 3-13b, the phase simulations are also very similar between these two tools. Therefore, it appears both of these simulators were able to analyze the interdigitated capacitor, although measured data would be required to ultimately judge the accuracy of the simulations.

3.2.6 Summary of MMWCAE Benchmarks

The five benchmarking examples presented in this section were chosen to demonstrate the variety of benchmarks published in the *International Journal of Microwave and Millimeter-Wave Computer-Aided Engineering*. In some benchmarks, the different simulation tools yielded nearly identical responses, whereas other benchmarks had widely different responses between tools. In addition, the grid size used by the simulator was also shown to affect the overall simulation. In summary, these examples demonstrate the variability in simulator benchmarking and again underscore the importance of testing the simulation tools over a wide variety of problems as part of any benchmarking study. In addition, these benchmarks also emphasize the need for standards such as analytical models or measured data to ultimately judge the simulations, since comparisons solely between different simulators is not always conclusive.

4.0 CONCLUSIONS

The modeling and simulation of MMICs and interconnects in microwave packages is one of the largest areas of application for electromagnetic simulation tools. These simulation tools, which were only developed as commercial products within the past decade, are very powerful since they can model the interactions of elements based upon their physical layout. As a result, these tools require fairly robust computers to generate solutions, often requiring hours or days to analyze moderately complex problems. However, as development in these tools continue to mature, electromagnetic simulation is gaining wide acceptance with designers. In this report, we have offered a general evaluation of electromagnetic simulation techniques. After a brief introduction to electromagnetic simulation, we next evaluated a number of commercially available simulation tools against a performance criteria. This criteria was developed to address key issues important to electromagnetic simulation and present this information in a clear and concise manner. In this presentation, we demonstrated that not all of the simulators offer the same features, and a careful investigation of these features should be a part of any software evaluation. Following the performance criteria, we next discussed two sets of benchmarking results. Specifically, we reported on the benchmarking studies published in *Microwave Engineering Europe* and the *International Journal of Microwave and Millimeter-Wave Computer-Aided Engineering*. After a brief discussion of the philosophy of simulator benchmarking, we discussed these two benchmark studies comparing a number of 2.5D and 3D simulation tools over a wide variety of problems. Among other things, these benchmarks demonstrated that different simulation tools can generate different results for the same problem. and presented resources available to designing a benchmarking study. Therefore, in this section we demonstrated the need to chose a wide variety of examples as part of any benchmarking study in order to get an overall indication of the simulator performance.

REFERENCES

- [1] *EM*, published by Sonnet Software Inc., 1020 Seventh North Street Suite 210, Liverpool, NY 13088, USA. *EM* and *EMPath* are trademarks of Sonnet Software Inc..
- [2] *IE3D*, published by Zeland Software Inc., 39120 Argonaut Way, Suite 499, Fremont, CA 94538, USA. *IE3D* is a trademark of Zeland Software Inc.
- [3] *Maxwell Strata*, published by Ansoft Corporation, Four Station Square, Suite 660, Pittsburgh, PA 15219-1119, USA. *Maxwell Strata* is a trademark of Ansoft Corporation.
- [4] *Microwave Explorer*, published by Compact Software, 201 McLean Boulevard, Paterson, NJ 07504, USA. *Microwave Explorer* is a trademark of Compact Software.
- [5] *Momentum*, published by Hewlett-Packard Company, 1400 Fountain Grove Parkway, Santa Clara, CA 95052, USA. *Momentum* is a trademark of Hewlett-Packard Company.
- [6] *SFPMIC+*, published by Jansen Microwave GmbH, Kackerstr. 16-18, D-52072, Aachen, Germany. *SFPMIC+* is a trademark of Jansen Microwave GmbH.
- [7] *HFSS*, published by Hewlett-Packard Company, 1400 Fountain Grove Parkway, Santa Clara, CA 95052, USA. *HFSS* is a trademark of Hewlett-Packard Company.
- [8] *MAFIA*, published by CST Computer Simulation Technology GmbH, Lauteschlägerstraße 38, 64289, Darmstadt, Germany. *MAFIA* is a trademark of CST GmbH.
- [9] *Maxwell Eminence*, published by Ansoft Corporation, Four Station Square, Suite 660, Pittsburgh, PA 15219-1119, USA. *Maxwell Eminence* is a trademark of Ansoft Corporation.
- [10] *Micro-Stripes*, published by KCC Ltd., 104 GPT Business Park, Technology Drive, Beeston, Nottingham NG9 2ND, United Kingdom. *Micro-Stripes* is a trademark of KCC Ltd.
- [11] *Quicksilver*, published by Sandia National Laboratory, Albuquerque, NM, 87185, USA. *Quicksilver* is a trademark of the Sandia Corporation.
- [12] *Quickwave 3D*, published by QWS, Warsaw, Poland. *Quickwave 3D* is a trademark of QWS.

- [13] Goldfarb, M. And A. Platzker, "The Effects of Electromagnetic Coupling on MMIC Design", *Int. J. MIMICAE*, Vol. 1, No. 1, Jan. 1991, pp. 38-47.
- [14] *EMPipe, EMPipe 3D, and Empipe Express*, published by Optimization Systems Associates Inc., P.O. Box 8083, Dundas, Ontario, L9H 5E7, Canada. *EMPipe, EMPipe 3D, and Empipe Express* are trademarks of Optimization Systems Inc.
- [15] "Evaluation of Electromagnetic Software", Sonnet Software Inc., 1020 Seventh North Street Suite 210, Liverpool, NY 13088.
- [16] "CAD Benchmark: Electromagnetic Simulators", *Microwave Engineering Europe*, November 1994, pp. 11-20.
- [17] "EM Simulation Benchmark", *Microwave Engineering Europe*, May 1995, pp. 23-26.
- [18] Bahl, I. J., "MIC Simulation Column", *Int. J. MIMICAE*, Vol. 1, No. 1, Jan. 1991, pp. 112-113.
- [19] Bahl, I. J., "MIC Simulation Column", *Int. J. MIMICAE*, Vol. 1, No. 2, April 1991, pp. 249-250.
- [20] Bahl, I. J., "MIC Simulation Column", *Int. J. MIMICAE*, Vol. 1, No. 3, July 1991, pp. 315-325.
- [21] Bahl, I. J., "MIC Simulation Column", *Int. J. MIMICAE*, Vol. 1, No. 4, Oct. 1991, pp. 412-419.
- [22] Bahl, I. J., "MIC Simulation Column", *Int. J. MIMICAE*, Vol. 2, No. 1, Jan. 1992, pp. 61-65.
- [23] Bahl, I. J., "MIC Simulation Column", *Int. J. MIMICAE*, Vol. 2, No. 2, April 1992, pp. 116-130.
- [24] Bahl, I. J., "MIC Simulation Column", *Int. J. MIMICAE*, Vol. 2, No. 3, July 1992, pp. 203-206.
- [25] Bahl, I. J., "MIC Simulation Column", *Int. J. MIMICAE*, Vol. 3, No. 1, Jan. 1993, pp. 76-97.
- [26] Bahl, I. J., "MIC Simulation Column", *Int. J. MIMICAE*, Vol. 3, No. 2, April 1993, pp. 156-157.
- [27] Bahl, I. J., "MIC Simulation Column", *Int. J. MIMICAE*, Vol. 3, No. 3, July 1993, pp. 295-311.
- [28] Bahl, I. J., "MIC Simulation Column", *Int. J. MIMICAE*, Vol. 3, No. 4, Oct. 1993, pp. 459-470.

- [29] Bahl, I. J., "MIC Simulation Column", *Int. J. MIMICAE*, Vol. 4, No. 1, Jan. 1994, pp. 120-121.
- [30] Bahl, I. J., "MIC Simulation Column", *Int. J. MIMICAE*, Vol. 4, No. 2, April 1994, pp. 203-212.
- [31] Bahl, I. J., "MIC Simulation Column", *Int. J. MIMICAE*, Vol. 4, No. 3, July 1994, pp. 315-323.
- [32] Bahl, I. J., "MIC Simulation Column", *Int. J. MIMICAE*, Vol. 4, No. 4, Oct. 1994, pp. 411-431.
- [33] Bahl, I. J., "MIC Simulation Column", *Int. J. MIMICAE*, Vol. 5, No. 1, Jan. 1995, pp. 40-49.
- [34] Bahl, I. J., "MIC Simulation Column", *Int. J. MIMICAE*, Vol. 5, No. 2, March 1995, pp. 131-135.
- [35] Bahl, I. J., "MIC Simulation Column", *Int. J. MIMICAE*, Vol. 5, No. 3, May 1995, pp. 234-236.
- [36] Bahl, I. J., "MIC Simulation Column", *Int. J. MIMICAE*, Vol. 5, No. 4, July 1995, pp. 360-367.
- [37] Bahl, I. J., "MIC Simulation Column", *Int. J. MIMICAE*, Vol. 5, No. 5, Sept. 1995, pp. 415-417.
- [38] "EM CAD Benchmark: The Vendors Respond", *Microwave Engineering Europe*, December/January 1995, pp. 12-13.
- [39] Rautio, J. C., "MIC Simulation Column - Some Stripline Standard Results", *Int. J. MIMICAE*, Vol. 5, No. 4, Sept. 1995, pp. 365-367.
- [40] Rautio, J. C., "An Ultra-high Precision Benchmark for Validation of Planar Electromagnetic Analyses", *IEEE Trans. Microwave Theory Tech.*, Vol. 42, No.11, Nov. 1994, pp. 2046 - 2050.
- [41] Rautio, J. C., "An Investigation of An Error Cancellation Mechanism With Respect to Subsectional Electromagnetic Analysis Validation", accepted for publication *Int. J. MIMICAE*, May 1, 1996.