

O

AR-009-916

DSTO-TR-0435

F

Broadband Active Sonar:
Implications and Constraints

H. Lew

S

19970307 106

D

APPROVED FOR PUBLIC RELEASE

DTIC QUALITY INSPECTED 4

© Commonwealth of Australia

Mar 13

THE UNITED STATES NATIONAL
TECHNICAL INFORMATION SERVICE
IS AUTHORISED TO
REPRODUCE AND SELL THIS REPORT

Broadband Active Sonar: Implications and Constraints

H. Lew

**Maritime Operations Division
Aeronautical and Maritime Research Laboratory**

DSTO-TR-0435

ABSTRACT

The broadband sonar concept has an impact on all areas of an active sonar system. This includes the signal processing of transmit-receive signals, the response of the medium and the target response. Beginning with the definition of a broadband signal, the implications of broadband signal processing in terms of matched filtering, pulse compression, low probability of interception and beamforming are examined. This is followed by an investigation of the constraints imposed on the propagation of broadband signals by the medium. Finally, a brief discussion on the use of broadband techniques for target classification concludes the report.

RELEASE LIMITATION

Approved for public release

D E P A R T M E N T O F D E F E N C E

DEFENCE SCIENCE AND TECHNOLOGY ORGANISATION

Published by

*DSTO Aeronautical and Maritime Research Laboratory
PO Box 4331
Melbourne Victoria 3001*

Telephone: (03) 9626 8111

Fax: (03) 9626 8999

© Commonwealth of Australia 1996

AR No. AR-009-916

October 1996

APPROVED FOR PUBLIC RELEASE

Broadband Active Sonar: Implications and Constraints

Executive Summary

The basic motivation for using broadband sonar is to improve the range resolution capabilities without sacrificing the detection performance, which is governed by the amount of received energy from the target. This can be achieved by increasing the bandwidth of the signals used. From this improvement in range resolution, a number of other desirable features follow such as improved range accuracy, robust parameter estimation, Doppler tolerance and so on.

The report begins by examining the definition of a broadband signal. The fractional bandwidth and time-bandwidth product definitions are discussed. This naturally leads on to a discussion of broadband signal processing which includes matched filtering, pulse compression techniques, low probability of interception signals and beamforming.

Having examined the signal processing aspects, it is then necessary to determine the response of the medium to the transmission of broadband signals. By using propagation models or experimental data the usable broadband frequency range can be determined for a given sonar system - environment scenario. For one example it was found that a spread of frequencies between 100 to 2000 Hz could be transmitted without significant distortion across the spectrum over a minimum range of 10 km given a probability of detection of 90% and false alarm probability of one in ten thousand.

Finally the report gives a brief discussion on the implications of target classification using broadband techniques such as resonance scattering and high resolution range profiling.

Authors

H. Lew

Maritime Operations Division

Henry Lew completed B.E. (Electrical/Electronics) and B.Sc.(Hons - physics) degrees at the University of Melbourne in 1985 and 1986 respectively. He was awarded a Ph.D in physics at the University of Melbourne in 1990. From 1990 to 1995 he was a post-doctoral research fellow, working in the area of high energy physics, at the University of Melbourne, Purdue University and the Institute of Physics - Academia Sinica. In 1995 he joined DSTO as a research scientist working in the area of active sonar signal processing.

Contents

1. INTRODUCTION	1
2. BROADBAND SIGNALS.....	2
2.1 Fractional bandwidth definition	2
2.2 Time-bandwidth product definition.....	4
3. BROADBAND SIGNAL PROCESSING	7
3.1 Matched filtering	7
3.2 Pulse compression	9
3.3 Low probability of interception.....	11
3.4 Beamforming	12
4. PROPAGATION OF BROADBAND SIGNALS.....	15
5. TARGET CLASSIFICATION	21
6. CONCLUSIONS	22
7. REFERENCES	23
8. APPENDIX.....	29

1. Introduction

In active sonar systems pulses with a single carrier frequency are often employed because of their simplicity and ease of implementation. They are sometimes referred to as "simple" signals and have the property that their time-bandwidth product is of the order of unity. This property makes long range detection incompatible with high range resolution as detection essentially depends on the amount of energy received from the desired target. Improved detection can be expected by increasing the peak power and/or the pulse length. In particular, long range detection requires the target echo to have a sufficiently large amplitude since the amplitude decreases with range[1]. In practice, however, transmitter limitations (e.g., transducer dynamics, cavitation, interaction effects etc) prevent excessive peak power outputs. Alternatively the amount of detectable energy can be increased by lengthening the pulse duration but this comes at the expense of reduced range resolution. This is because the range resolution is determined by the bandwidth of the signal, which for "simple" signals goes as the reciprocal of the pulse length. To avoid this inherent conflict between the needs of reliable detection and good range resolution signals other than the "simple" ones have to be used. These are signals with large time-bandwidth products and are generally classed as broadband signals. In this report an overview of broadband signals and systems in the context of active sonar will be given.

There are several areas of an active sonar system in which the use of broadband signals will have a significant influence. For the purposes of analysis and discussion it is useful to divide the sonar system into three broad subsystems as shown in Fig. 1.

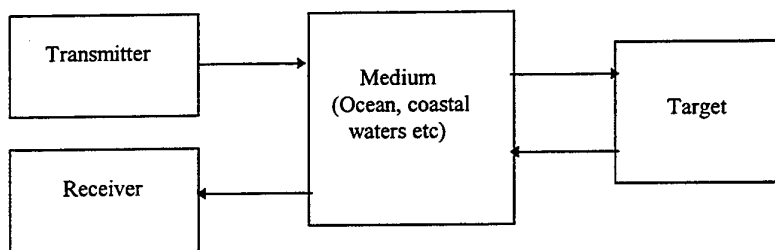

Figure 1. Generic active sonar system. Note that the transmitter and receiver need not be in the same location.

The transmitter-receiver block will be discussed in sections 2 and 3. This will deal with the definition of broadband signals and the signal processing aspects of broadband. Section 4 will look at the impact of the medium on the propagation of broadband signals. In section 5 the implications of broadband for the target will be discussed in terms of target strength measurements and classification. The relationship between all

three of these areas from a systems viewpoint is tied together in a conceptual framework shown in Fig. 2.

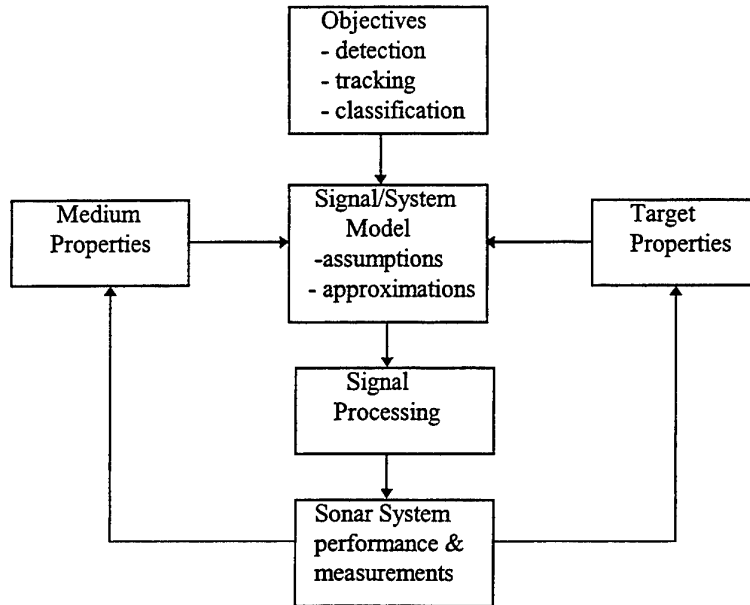

Figure 2. Conceptual framework of sonar system modelling.

2. Broadband Signals

2.1 Fractional bandwidth definition

Intuitively, a broadband signal is one which has a significant amount of its energy distributed over a wide range of frequencies. At present there is no standardised definition of what a broadband signal is. The terms broadband and narrowband can have several meanings depending on the application. Note that broadband is sometimes referred to as *wideband* in the literature. Other terms such as impulse, nonsinusoidal, baseband, video pulse and time domain are also used in connection with broadband signals depending on the application. In this report two definitions of what a broadband signal is will be adopted. The first is a quantification of the intuitive notion of a broadband signal and the second is derived from the limitations of the sonar signal model.

Firstly, consider the definition of the bandwidth of a signal. The bandwidth is the frequency range within which a significant fraction of the total energy of the signal lies. Here "significant" could, for example, be something like 90% or 95% of the total energy. The precise value chosen is somewhat arbitrary and will usually depend on the application. This lack of a unique and precise definition of bandwidth is one of the reasons why the definition of broadband is also imprecise. By using this definition one can write the fractional bandwidth, which is the ratio of the bandwidth to the average frequency within that band, as

$$\Delta = \frac{f_u - f_l}{\frac{1}{2}(f_u + f_l)} \quad , \quad (1)$$

where f_u and f_l are the upper and lower limits of the specified frequency range respectively. A signal is considered to be broadband if the fractional bandwidth is greater than some nominal value, e.g., $\Delta \geq 0.1$, otherwise it is narrowband. A narrowband signal can be envisaged as one that approximates a sinusoid as $\Delta \rightarrow 0$.

This definition of a broadband signal can be motivated from the complex signal model which assumes that the signal can be written in the form

$$s(t) = \text{Re}\{\mu(t)\} = \text{Re}\{a(t) \exp(j2\pi f_c t)\} \quad (2)$$

where $a(t)$ is the low frequency (complex) envelope and the exponential term contains the high frequency carrier. This representation is valid as long as the frequency spectrum of $\mu(t)$ does not have any negative frequencies (i.e., the complex signal is a good approximation to the so-called analytic signal, see appendix A) and when this is the case the signal is considered to be narrowband. Therefore the signal is broadband when the spectrum of $\mu(t)$ contains negative frequencies, i.e., $\Delta f > f_c$, where $\Delta f = \frac{1}{2}(f_u - f_l)$ and $f_c = \frac{1}{2}(f_u + f_l)$ (see Fig. 3). This means, for a narrowband signal, the envelope cannot vary at a rate that is comparable to the carrier frequency unless the distortion to the complex signal representation is deemed acceptable. In other words, for broadband signals, the carrier frequency term cannot be separated from the envelope.

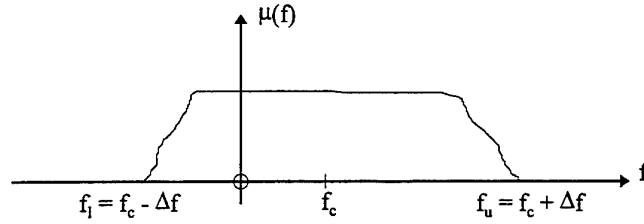

Figure 3. Broadband frequency spectrum of a complex signal with negative frequencies.

2.2 Time-bandwidth product definition

The above fractional bandwidth definition of a broadband signal is quite general. In active sonar a more specific and perhaps useful definition can be formulated in terms of the signal model used and its processing. It turns out that the time-bandwidth product of the received signal will determine whether the signal should be treated as broadband or narrowband. To see this consider the "slowly fluctuating point target" model[2]. The returned signal of an active sonar system after scattering from a target can be modelled as

$$r(t) = \text{Re} \left\{ \alpha a(t - \tau(t)) \exp \left[j2\pi f_c (t - \tau(t)) \right] \right\}, \quad (3)$$

where α is a complex random variable describing the signal attenuation (caused by transmission loss and target scattering) and the range uncertainty of the target; f_c is the carrier frequency; and $\tau(t)$ is the time dependent round trip time delay. This time delay can be written as a function of the instantaneous range of the target, $R(t)$, such that

$$\tau(t) = \frac{2}{c} R \left[t - \frac{1}{2} \tau(t) \right], \quad (4)$$

with c being the speed of sound in the medium. By expanding Eq. (4) in a Taylor series about the initial delay, $\tau_0 = 2R_0/c$, and assuming that the target moves with *constant velocity*, then

$$t - \tau(t) = \frac{1}{s} (t - \tau_0), \quad (5)$$

where

$$s = \frac{c+v}{c-v} \quad (6)$$

is the scaling factor and $v = v(\tau_0)$ is the radial velocity of the target. The returned signal of Eq. (3) can now be rewritten as

$$r(t) = \text{Re} \left\{ \alpha a \left(\frac{t-\tau_0}{s} \right) \exp \left[j2\pi (f_c + f_d) (t-\tau_0) \right] \right\}, \quad (7)$$

where the Doppler shift, f_d , was introduced through

$$\frac{1}{s} f_c = f_c + f_d \quad \text{with} \quad \frac{f_d}{f_c} = \frac{-2v/c}{1+v/c}. \quad (8)$$

The form of Eq. (6) shows two effects on the returned signal which are caused by the target velocity:

- The signal envelope is stretched or compressed by the scaling factor s .
- The carrier frequency is Doppler shifted by an amount f_d .

In the narrowband approximation the scaling of the signal envelope is neglected. To see under what conditions this is valid compare the two waveforms $a(t)$ and $a(t/s)$. The error between the two is maximum (see Fig. 4) when $t = T$, e.g., the length of the pulse. If the bandwidth of $a(t)$ is B then the time resolution cell size is $1/B$, meaning that the signal does not change significantly during this time interval. Therefore the error between $a(T)$ and $a(T/s)$ is small if $|T - T/s| \ll 1/B$. This can be rewritten as

$$TB \ll \left| \frac{s}{s-1} \right| \quad \text{or} \quad TB \ll \frac{c}{2v} \quad \text{for } v \ll c. \quad (9)$$

The signal is considered to be *broadband* if this condition is violated.

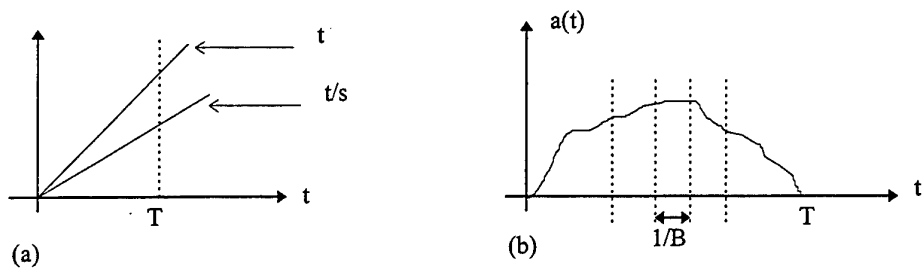

Figure 4. (a) the difference between the arguments of the envelope function and (b) the resolution cell size of the envelope function.

Note that the condition $TB > 1$ may not be a sufficient requirement for a signal to be classed as broadband in accordance with the above definition. This can be illustrated by the following example. Consider two target velocities: (a) 50 knots and (b) 1 knot. By using Eq. (9) the signal will be narrowband if the time-bandwidth product is much less than 30 for case (a) and 750 for (b). If the required time-bandwidth product of the signal is 100 then the signal is broadband for case (a) whereas it can be considered narrowband in case (b). This result also explains why radar signals with substantial fractional bandwidths can be treated in the narrowband approximation given that the propagation speed of radar signals is several orders of magnitude greater than that of underwater sound.

An important assumption used in the derivation of Eq. (9) is that the target maintains a constant velocity during the observation interval. This implies that narrowband processing, which is limited by the signal's bandwidth, can be used to model a system provided its accelerations are negligible. Since broadband processing is required when the time-bandwidth product of the signal is of the order of $c/2v$, the performance of a narrowband system should be best when the target velocities are small. Similarly, when the accelerations of the system become non-negligible the performance of broadband processing is expected to fall. This limitation of broadband processing can be expressed quantitatively as follows. The acceleration of the target is said to be non-negligible when the change in velocity is of the same order as the velocity, i.e., $\Delta v \sim v \approx \frac{c}{2TB}$. Writing the acceleration as $a \approx \frac{\Delta v}{T}$, then

$$T \approx \sqrt{\frac{c}{2aB}} \quad (10)$$

It is evident from Eq. (10) that large accelerations reduce the amount of processing time available for broadband systems.

In summary, velocities degrade the performance of narrowband systems whereas accelerations degrade the performance of broadband systems. The advantage of broadband systems is that they allow a larger processing interval which results in greater gain, better noise immunity and increased range resolution.

3. Broadband Signal Processing

3.1 Matched filtering

The matched filter[3] is central to active sonar signal processing. Fundamentally, the matched filter is a correlator which compares the received signal with a hypothesised signal (or set of signals). The output of the matched filter gives a measure of how well the hypothesised signal (sometimes referred to as the replica) matches the received signal as a function of a set of parameters, usually the range and velocity of the target. By using this information some properties of the target can be inferred.

More specifically, the matched filter output is proportional to

$$\chi(\tau, s) = \int x(t) y^* \left(\frac{t - \tau}{s} \right) dt \quad (11)$$

where

$\chi(\tau, s)$ is the broadband ambiguity function[4],

$x(t) = r(t) + n(t)$ is the received signal plus noise waveform,

$y(t)$ is the hypothesised signal as a function of time delay, τ , and scale factor, s (see Eqs. (5) and (6)).

Eq. (11) can also be represented diagrammatically as shown in Fig. 5.

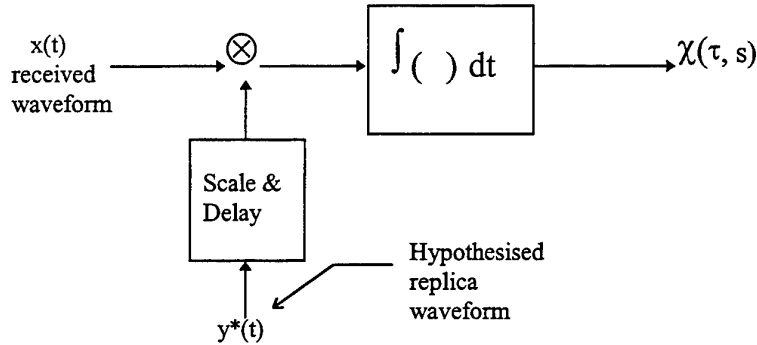

Figure 5. Schematic of the broadband ambiguity function

If the received signal is bandpass, i.e., some low pass function, $f_{LP}(t)$, modulating a carrier with frequency f_c , then the received signal and its replica can be written as

$$x(t) = x_{LP}(t) \exp(j2\pi f_c t) \quad \text{and} \quad y(t) = y_{LP}(t) \exp(j2\pi f_c t), \quad (12)$$

so that

$$\chi(\tau, s) = \exp\left(j2\pi f_c \frac{\tau}{s}\right) \int x_{LP}(t) y_{LP}^* \left(\frac{t-\tau}{s}\right) \exp(-j2\pi f_c t) dt \quad (13)$$

The magnitude of the ambiguity function for this case is independent of the carrier which makes it easier to implement digitally since only low pass waveforms have to be sampled. Note that in the limit as $s \rightarrow 1$, the ambiguity function in Eq. (13) reduces to the well known narrowband ambiguity function used extensively in radar applications[5].

The ambiguity function is a useful tool for analysis and provides a starting point for waveform synthesis. The waveform synthesis problem, which consists of finding the appropriate signal given a specified ambiguity function, is still an open problem. Nevertheless, from the experience of radar signal processing, waveforms can be classified into three broad classes of ambiguity functions: the ridge, the thumbtack and the bed of spikes. The ridge function, particularly if the axis of the ridge is oriented towards the Doppler axis, is useful for the detection of targets with unknown velocities. The technique of pulse compression is one means of realising such an ambiguity function. The thumbtack function, usually considered as an approximation to the "ideal" ambiguity function, can be realised through the use of pseudo-random waveforms. Both classes of ambiguity functions rely on waveforms with a large time-

bandwidth product. The bed of spikes function is obtained whenever a train of pulses is used. Schematic representations of these ambiguity functions are shown in Fig. 6.

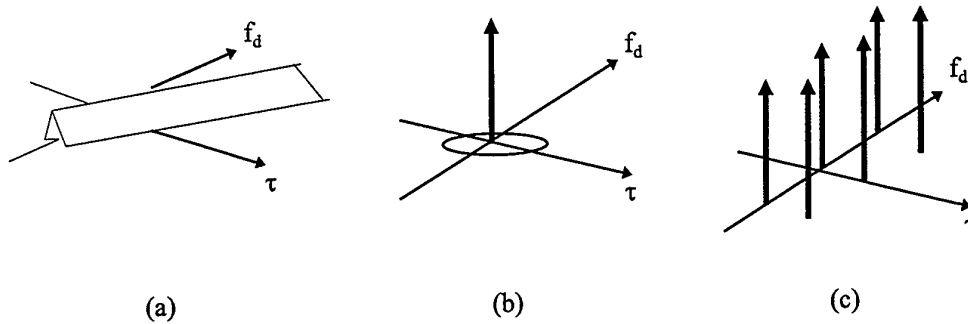

Figure 6. Classes of ambiguity functions: (a) the ridge, (b) thumbtack and (c) bed of spikes.

3.2 Pulse compression

If energy considerations are ignored then the short pulse has a number of desirable features because of its relatively large bandwidth. These include

- good range resolution; the ability to separate multiple targets in a given range interval or resolve individual scattering centres in a finite sized target
- good range accuracy, which follows from good range resolution
- mutipath resolution
- a shorter minimum range, where $R_{\min} = \frac{1}{2} cT_p$ for a pulse duration of T_p
- target classification through better feature extraction
- Doppler tolerance; a single filter matches a wide range of Doppler shifts

The use of explosive charges is one way to generate short pulses with adequate energy though this may not be always operationally desirable. Alternatively the use of pulse compression techniques can take advantage of the benefits of a short pulse without the constraints of peak power limitations.

Pulse compression[6] occurs if a waveform with a nonlinear phase spectrum is passed through a filter that is phased matched to the waveform. A signal with a nonlinear phase spectrum is one whose phase is a nonlinear function of time. A phased matched

filter is one whose phase response is equal and opposite to that of the waveform. (This is just a special case of the matched filter described in the previous section.) The basic idea is best illustrated by the classic example of linear frequency modulation (LFM).

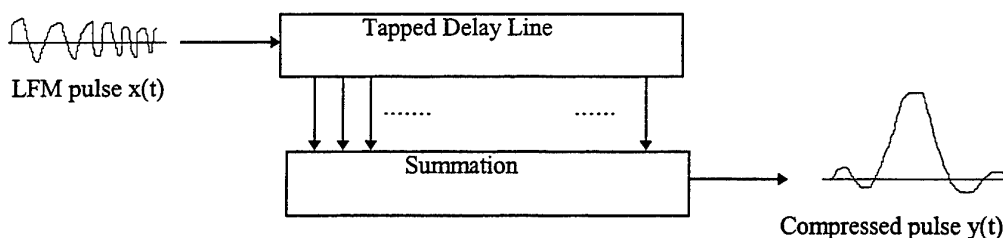

Figure 7. Pulse compression using a tapped delay line and summation configuration.

Consider the setup in Fig. 7 where the tapped delay line and summation configuration is a realization of a matched filter for the input LFM waveform. The output is given by

$$y(t) = \int x(\tau) h(t - \tau) d\tau \quad (14)$$

where $h(t) = x^*(-t)$ is the matched filter condition (for simplicity the time delay for making the impulse response causal has been neglected). Let the input LFM waveform be described as

$$x(t) = \frac{1}{\sqrt{T}} \exp\left\{j2\pi\left[f_c t + \frac{B}{2T}t^2\right]\right\} \quad \text{for } |t| \leq \frac{T}{2} \quad (15)$$

where T is the pulse length and B is the frequency sweep (this is a good measure of the signal's bandwidth if $TB \geq 50$). The compressed pulse is then given by

$$y(t) = \exp(j2\pi f_c t) \frac{\sin\left[\pi B t \left(1 - \frac{|t|}{T}\right)\right]}{\pi B t} \quad \text{for } |t| \leq T. \quad (16)$$

For sufficiently large time-bandwidth products Eq. (16) has zeros for $t \approx \frac{n}{B}$ for $|t| \leq T$,

where n is an integer. This means that the LFM waveform with a pulse length T is compressed to a pulse whose length is $2/B$. The compression ratio, which is a measure of the amount of pulse compression, is given by $TB/2$, proportional to the time-bandwidth product of the uncompressed signal.

From the above analysis it is evident that a LFM pulse can be quite long in duration. However, since each instant of the pulse is associated with a unique frequency, the processor can combine different parts of the pulse in such a way so that the output is a narrow "spike" which accurately specifies the target delay time.

Another form of pulse compression which has received wide application is the phase-coded waveform. This can be achieved when a long pulse of duration T is divided into N subpulses each of length T_s . The phase of each subpulse can either be 0 or π . If these two possibilities are chosen randomly then the waveform approximates a noiselike signal with a thumbtack type ambiguity function. The basic idea behind the processing is that the sequence of short pulses is combined into a single large pulse with many of the small pulses as sidelobes. The compressed waveform has a width T_s and an amplitude N times the original. A special phase-coded sequence is the Barker code which has the property that its autocorrelation function has equal time-sidelobes[7].

It should be noted that there are many types of pulse compression waveforms. These include nonlinear FM, discrete frequency shift, polyphase codes, compound Barker codes and so on. All these waveforms have their particular desirable features but they come at the cost of more complicated processing and the practical difficulties associated with their implementation.

3.3 Low probability of interception

A necessary condition for a signal to have a low probability of interception (LPI) is that it has a sufficiently large time-bandwidth product. Many of the waveforms used for LPI are similar to the pulse compression ones. However, to be effective as an LPI signal, the design of the signal carrier must be complex enough so that its timing, frequency or phase pattern cannot be predicted by an unintended interceptor. Thus the carrier should be highly variable over the interval in which the message or baseband signal is nearly constant. This means that the modulated signal must have a bandwidth larger than the message rate, the baseband bandwidth. In general, a LPI signal requires its total bandwidth, B , to be much greater than the message rate of $1/T$, where T is the duration of the baseband signal, i.e., $TB \gg 1$. The objective is to make the broadband signal appear noiselike for the potential interceptor. The technique used to achieve LPI signals is referred to as spread spectrum modulation[8].

To demonstrate the above consider a signal transmitted using some sort of spread spectrum modulation. Assume that this signal at the intended receiver has a power, S , with bandwidth, B , over a signalling interval, T . Also assume that the interceptor has a bandwidth W which is smaller than B . Then the signal to noise ratio (SNR) at the interceptor is

$$SNR_I = \frac{k_I SW/B}{N_I W} = \frac{k_I k E}{N_I BT} \tag{17}$$

where k_I is a factor accounting for the receiver gain, propagation and other losses at the interceptor, N_I is the interceptor's noise spectral density and the intended receiver power can be written as $S = k E/T$, with E being the transmitted energy over the signalling interval and k is a constant of proportionality. Therefore a large time-bandwidth product can give rise to a relatively small interceptor SNR.

3.4 Beamforming

The discussion so far has assumed that the received signal has already been spatially filtered and is in a form suitable for temporal processing. The objective of spatial filtering or beamforming is to estimate the signal coming from a desired direction. It is clear from the preceding discussions that broadband signals, whether designed for the purpose of high range resolution or low probability of interception, are characterised by their relatively large time-bandwidth product and their implications and constraints on spatial filtering need to be considered.

Beamforming is based on the idea of coherently summing the received signals coming from different spatial locations. It will become evident from the following discussion that the time delay between received signals is the fundamental quantity in broadband beamforming rather than the phase shift equivalent which is used extensively for the narrowband case.

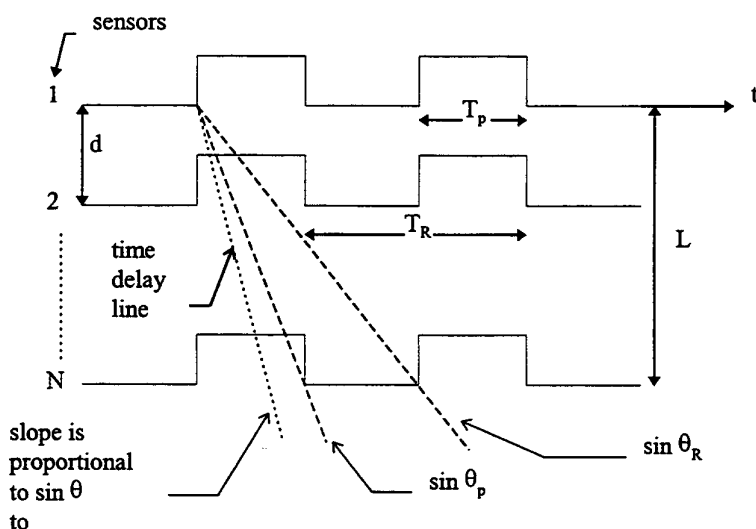

Figure 8. Schematic of time domain beamforming.

To illustrate the concepts behind the beamforming of broadband signals consider the linear equi-spaced array depicted in Fig. 8. For simplicity, assume that the array is set up to coherently sum broadside signals (additional pre-steering delays are required for the coherent summation of off-broadside signals). The rectangular pulses shown are a generic representation of the envelope of the broadband signal. The actual waveform could be anything from an impulse-like signal to long duration nonsinusoidal signals[9] such as those used in LPI systems. From Fig. 8 note that all the sensors are ensonified as long as $\theta \leq \theta_p = \sin^{-1}(cT_p/L)$, where T_p is the pulse duration and θ is the angle of arrival of the wavefront measured from the broadside direction. As θ increases beyond θ_p fewer pulses will get summed and the resultant amplitude drops until $\theta_r = \sin^{-1}(cT_r/L)$ where T_r is the pulse repetition interval. At this stage grating lobes begin to make their appearance as pulses from the next period get summed.

From these simple considerations a number of observations can be made:

- The angular behaviour of the beam pattern is dependent on the time domain properties of the waveform. For instance, off broadside, the resultant waveform at the beamformer output becomes increasingly distorted relative to the broadside waveform.
- The beamwidth and grating lobes depend on the pulse duration and the pulse repetition interval. This is in contrast to the narrowband formulation of beamforming where the beamwidth and grating lobes depend on the carrier frequency.
- The shape of the waveform will have an important affect on the performance of the beamformer. It was found in Ref. [10] that the shape of the signal envelope for CW (continuous wave) pulses is an important factor in determining the directivity pattern. Smooth envelopes give a better directivity than ones which have sharp changes. It was also found that array weighting could not correct for badly designed signal shapes in this respect.
- In active sonar pulses much shorter than the acoustic aperture are often used. This can result in the whole array not being ensonified simultaneously and hence violating a standard assumption used for narrowband beamforming.
- The use of time limited signals in active sonar suggest that it is more pertinent to describe the beam pattern in terms of energy distribution with respect to angle rather than power, as is conventionally done in the narrowband case. Furthermore, for pseudorandomly coded signals, a truer performance measure of the receiver response might be given by the spatial distribution of correlatable energy[11].

The impression given by the foregoing discussion suggest a significant departure from narrowband beamforming concepts and techniques. Nevertheless, with the

abovementioned limitations in mind, it is possible to generalize the single frequency conventional beamformer to one that can process time-limited broadband signals. To see this, consider a linear array with N sensors. The beamformer output for a single frequency component (viz., the narrowband beamformer case) is

$$\sum_{i=1}^{N-1} w_i X_i(f) \exp(j(i\tau_s)) \tag{18}$$

where $X_i(f)$ is the Fourier transform of the signal $x_i(t)$ at the i th sensor, τ_s is the steering time delay between adjacent sensors and $w_i = W_i \exp[j(\pi z_i^2 / \lambda R)]$ is the sidelobe shading term with range focussing correction (z_i is the position of the i th sensor, λ is the wavelength and R is the range of the target measured from some reference sensor). Then the beamformer output for the entire frequency spectrum of the signal is

$$\int \sum_{i=1}^{N-1} w_i X_i(f) \exp(j(i\tau_s)) \exp(j2\pi ft) df . \tag{19}$$

This formulation of a broadband beamformer can be implemented using Fast Fourier Transform techniques[12] as shown in Fig. 9.

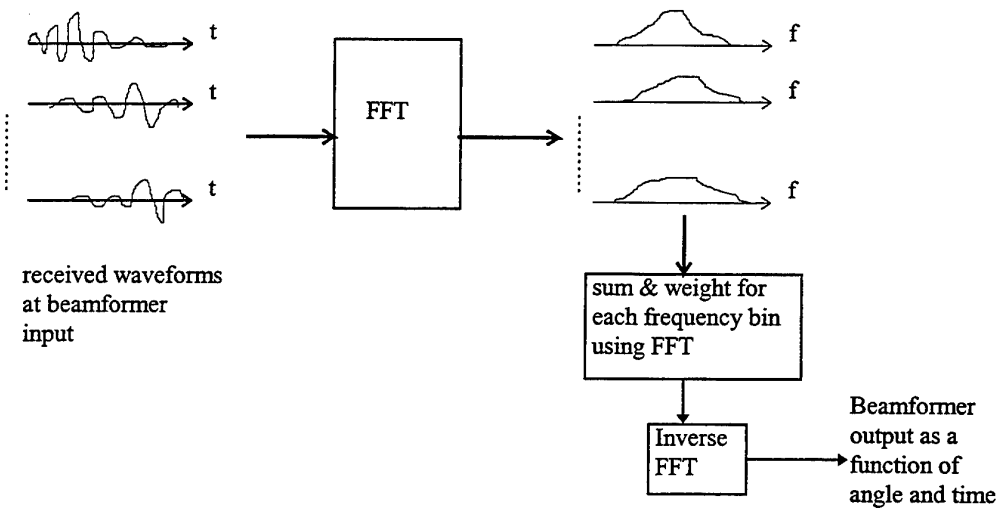

Figure 9. A FFT implementation of a broadband beamformer.

For some applications requiring the transmission and reception of broadband signals without significant deformation of its frequency spectrum it is desirable to have arrays capable of maintaining a constant beamwidth over a wide frequency range. This can be achieved by configuring the array such that each sub-array is tuned to a particular centre frequency so that the desired operating frequency range is covered by each sub-array. Examples of this technique can be found in [13].

4. Propagation of Broadband Signals

Up to now the discussion of broadband signal processing has implicitly assumed that broadband signals can be transmitted through the medium, i.e., the underwater environment, without suffering significant distortion to their frequency spectra. The purpose of this section is to see under what conditions this assumption is valid. More specifically, to determine the frequency range that supports broadband propagation for a given transmission loss. To do this an understanding of how signals propagate through the medium is essential.

From a study of ocean acoustic propagation it has been found that signal degradation results from a number of acoustic loss factors. These are the geometrical spreading loss (spherical, cylindrical etc), the volume absorption loss (due to viscosity and chemical relaxation), the bottom reflection loss (surface reflection loss is usually considered to be negligible due the large impedance mismatch between air and water) and the surface and bottom scattering loss. High frequencies are found to be strongly affected by boundary scattering and the microstructure variability of the ocean. Therefore volume and scattering losses increase with increasing frequency. At the other end of the spectrum very low frequencies are found to be strongly affected by the geoacoustic properties of the sea floor. This leaves the intermediate frequencies (of the order of 10 to 1000 Hz) being least affected by losses as the boundary and volume effects are minimized.

In order to get a quantitative measure of the "usable" frequency range the maximum and minimum detectable frequencies need to be determined. This can be done as follows:

1. Choose a sonar system configuration, i.e., monostatic or bistatic, the type of receiver etc.
2. Determine the maximum tolerable transmission loss from the specifications of the sonar system via the sonar equation[14].

- Determine the transmission loss characteristics of the medium, e.g., the ocean, as a function of frequency and range.

By combining the results in steps 2 and 3, the frequency range(s) with tolerable propagation losses can be determined. This is the frequency range that a broadband signal can be transmitted without suffering significant distortion across its frequency spectrum.

This procedure is best explained through an illustrative example. Consider, for simplicity, a monostatic configuration with the sonar receiver as shown in Fig. 10.

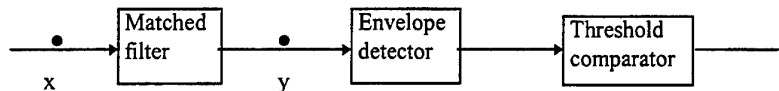

Figure 10. Noncoherent detector.

The signal to noise ratio of the receiver determines the probability of detection

$$P_d = \int_{\gamma}^{\infty} x \exp\left[-\frac{(x^2 + a^2)}{2}\right] I_0(ax) dx \quad (20)$$

for a given probability of false alarm, P_{fa} , where $\gamma = \sqrt{2 \log_e(1/P_{fa})}$, $a^2 = SNR(y)$ and $I_0(\)$ is the zeroth order modified Bessel function. Equation (20) can be presented as a set of receiver operating characteristic curves as shown in Fig. 11.

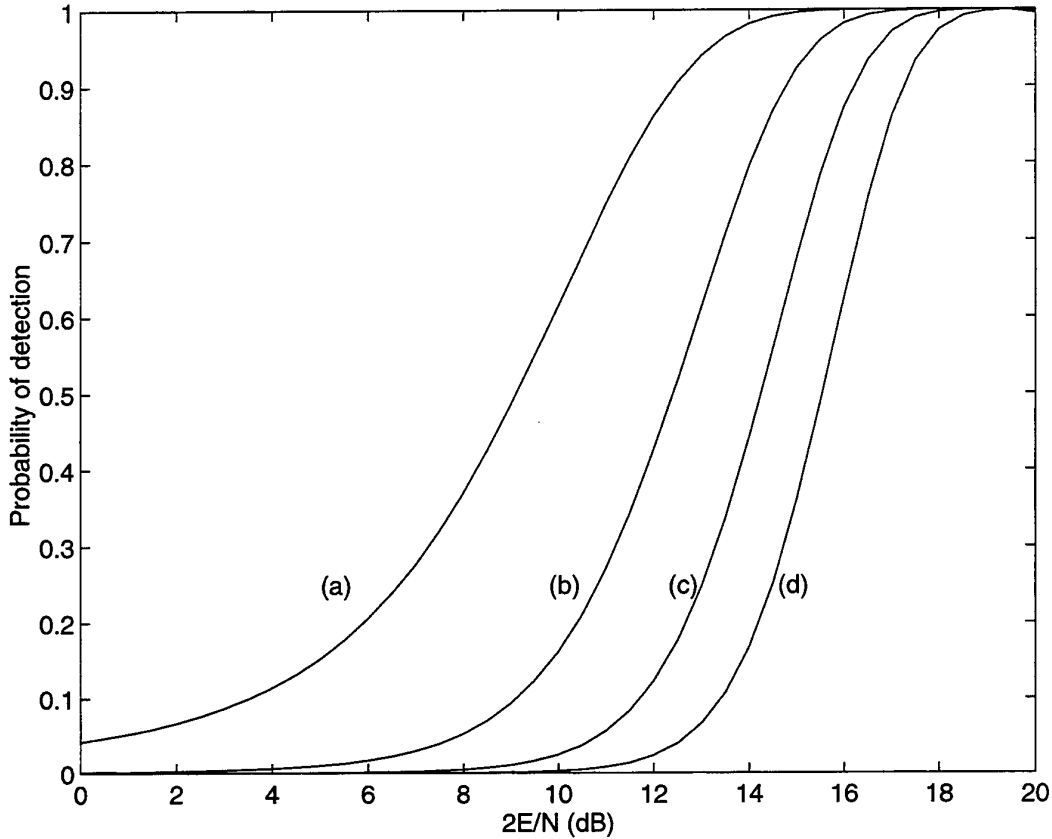

Figure 11. Noncoherent detector ROC curves for false alarm probabilities of (a) 10^{-2} , (b) 10^{-4} , (c) 10^{-6} and (d) 10^{-8} .

The signal to noise ratio at the output of the matched filter is $SNR(y) = 2E/N_0$, where E is the received signal energy and $N_0/2$ is the noise spectral density. For a signal of duration T and bandwidth, $2B_x$, at the beamformer output, the

$$SNR(x) = \frac{E/T}{N_0 B_x} = \frac{SNR(y)}{2B_x T}. \quad (21)$$

By specifying the required P_d and P_{fa} , then $SNR(y)$, and hence $SNR(x)$, can be determined. To continue, assume the following set of system parameters in a noise limited ocean environment:

1. Pulse length: $T = 0.1$ s

2. Directivity index: $DI = 10 \log_{10} \left(4\pi \frac{A_{eff}}{\lambda^2} \right) \approx 10 \text{ dB}$, where the size of the effective aperture, A_{eff} , of the receiving array is taken to be the same order of magnitude as the square of the design wavelength, λ^2 .
3. Source level: $SL = 200 \text{ dB}$ rel. $1 \mu\text{Pa}$ at 1 m .
4. Target strength: $TS = 10 \text{ dB}$
5. Noise level: $NL = 50 \text{ dB}$ rel. $1 \mu\text{Pa}$ normalized to a 1 Hz band.
6. Detection threshold: $DT_{Hz} = SNR(x)_{dB} = SNR(y)_{dB} - 10 \log_{10} T$, where $SNR(x)_{dB}$ has been normalized to a 1 Hz band to be consistent with the noise level specification.

By using the sonar equation the maximum tolerable transmission loss can be written as

$$TL = \frac{1}{2} (SL + TS - NL_{Hz} + DI - DT_{Hz}). \quad (22)$$

Table 1, by using Fig. 11, shows $SNR(y)$ for a given set of P_d and P_{fa} . The corresponding set of transmission losses calculated by Eq. (22) using the above set of system parameters is shown in table 2. This is the maximum tolerable propagation loss for a given specification of detection and false alarm probabilities.

Table 1. SNR as a function of detection and false alarm probabilities

$SNR(y)_{dB}$	$P_d = 0.5$	$P_d = 0.9$
$P_{fa} = 10^{-4}$	12.375	14.5
$P_{fa} = 10^{-8}$	15.5	17.25

Table 2. Transmission loss as a function of detection and false alarm probabilities

TL_{dB}	$P_d = 0.5$	$P_d = 0.9$
$P_{fa} = 10^{-4}$	73.8	72.8
$P_{fa} = 10^{-8}$	72.2	71.4

At this stage one can proceed in two ways to get the range of frequencies allowed by the limits set by Eq.(22) for a desired minimum range of detection. The first is to use experimental data of transmission loss which is a function of frequency and range, such as that shown in Fig. 12. For example, one such experiment was performed in coastal waters in the North Atlantic where explosive sources were used to map the transmission loss as a function of range and frequency. The results are given in Fig. 7(b) of Ref. [15]. Using these results for a maximum tolerable transmission loss of about 72 to 73 dB gives a frequency range between about 100 to 2000 Hz for a minimum range of 10 km. This is for a source and receiver depth of 50 m in a water column approximately 100 m deep.

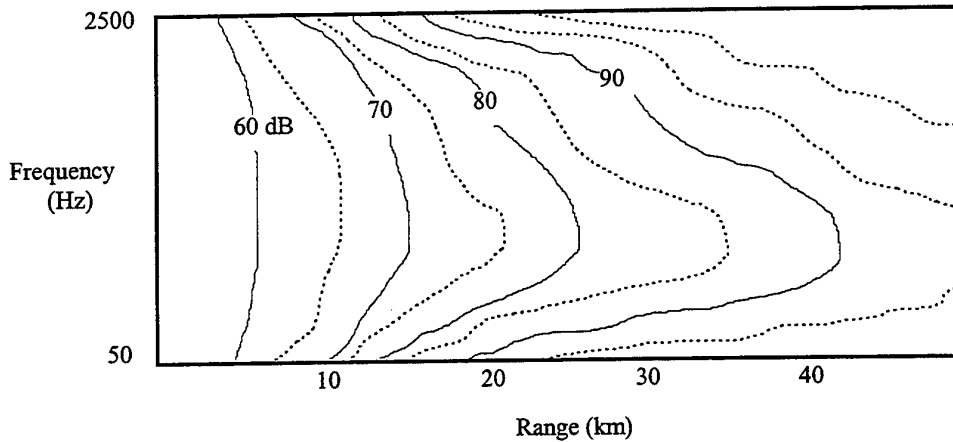

Figure 12. Schematic of a transmission loss contour plot as a function of range and frequency. The actual results are given in Ref. [15].

Alternatively, if experimental data is unavailable, the transmission loss as a function of range and frequency can be obtained by modelling. There are a number of models available. These include ray theory models, range independent wave models (e.g., Fourier Integral, Normal Modes) and range dependent wave models (e.g., Coupled Modes, Parabolic Equation, Finite Element) [16]. In any case, all these models have the common objective of solving the wave equation with a harmonic point source subject to the appropriate boundary conditions:

$$\nabla^2 \psi(r, z) + \left[\frac{\omega}{c(r, z)} \right]^2 \psi(r, z) = - \frac{\delta(r) \delta(z - z_0)}{2\pi r}, \quad (23)$$

where cylindrical symmetry has been assumed, $\psi(r, z)$ is the velocity potential, ω is the angular frequency of the source located at $r = 0$ and $z = z_0$ and $c(r, z)$ is the speed

of sound. For the purposes of continuing the example and demonstrating the ideas involved, a simple heuristic model will be used instead of the abovementioned more sophisticated models which are computationally intensive. A simple transmission loss model is given by

$$TL = 10 \log_{10}(r_0 \times 10^3) + 10 \log_{10}(r \times 10^3) + a(f)r \quad (24)$$

where r_0 is the transition region between the spherical and cylindrical spreading in km, r is the range in km and $a(f)$ is the attenuation in dB/km accounting for the volume and scattering losses as a function of frequency. To get an estimate of the maximum frequency, take $r_0 \approx H$ (e.g., $H \sim 100$ m), the depth of the water column or duct, and $a(f) \approx 0.1(f/\text{kHz})^2$, where the attenuation is assumed to be dominated by volume effects at high frequencies. The maximum frequency is given by

$$0.1 \left(\frac{f_{\max}}{\text{kHz}} \right)^2 \approx \frac{TL - 20 - 10 \log_{10}(r_{\min} \times 10^3)}{r_{\min}} \quad (25)$$

for a desired minimum range r_{\min} . For a minimum range of 10 km, the transmission loss values of table 2 give a maximum frequency of about 3.5 kHz.

To get the minimum frequency note that sound at very low frequencies tend not to be trapped in a duct when the wavelength becomes comparable to the dimensions of the duct or in the case of a water column, interaction with the bottom becomes significant. The maximum wavelength is given by[17]

$$\lambda_{\max} = \frac{8}{3} \sqrt{2} \int_0^H \sqrt{n(z) - n(H)} dz \quad (26)$$

where $n(z)$ is the index of refraction and H is the height of the duct or water column. For a constant sound velocity profile

$$\lambda_{\max} \sim 10^{-2} H^{3/2} \quad \text{or} \quad f_{\min} \sim 10^5 H^{-3/2}. \quad (27)$$

If $H \sim 100$ m then $f_{\min} \sim 100$ Hz. (It should be noted that limitations of the sonar hardware could set a higher value for the minimum frequency.) Therefore, by using the simple model, the useable broadband range of frequencies is expected to lie between 100 and 3500 Hz, which is not too different from the experimental result.

Although the above example only used a minimum range of 10 km, similar considerations can be applied to other range values and system parameters. Qualitatively, it is expected that the detectable range of frequencies will decrease with increasing minimum range. Having established that it is possible, under certain

conditions, to transmit a broadband range of frequencies without serious attenuation across its spectrum the next step would be to determine the propagation characteristics of actual broadband waveforms.

One approach is to treat the problem of broadband propagation as the same as that of a single frequency where this frequency represents the geometric mean of the upper and lower limits of the signal's frequency spectrum, i.e., $f_m = \sqrt{f_L f_U}$. This would be a reasonable approximation provided the signal's bandwidth is not too large and the spectrum remains fairly constant over the bandwidth of interest.

A more accurate approach would be to use existing propagation models to generate the wave solutions for each frequency of interest and then obtain the full waveform solution by Fourier synthesis[18], i.e.,

$$f(r, z, t) = \int_{-\infty}^{\infty} F(\omega) \psi(r, z, \omega) \exp(i\omega t) d\omega \quad (28)$$

where $F(\omega)$ is the temporal spectrum of the waveform and $\psi(r, z, \omega)$ is the spatial transfer function (in terms of range r , depth z and angular frequency ω) obtained from a number of frequency runs of a wave model program. Alternatively, one can attack the problem directly using time domain methods[19]. It should be noted that both these methods are computationally intensive.

5. Target Classification

The aim of target classification is to distinguish one target from another. In general, target classification requires an examination of the details of the echo from which one can hopefully establish a signature for that particular target in question. This usually requires a larger SNR and at a shorter range than that needed for detection. There are two methods of target classification which might benefit from the use of broadband signals. They are resonance scattering and high resolution range profiling.

The resonance scattering method[20] relies on the target's natural frequencies to be excited. A complex target can be modelled as a composite of standard geometric shapes (disks, cylinders, spheres etc). To get a reliable signature of the target it is desirable to excite as many resonances as possible. Therefore a sufficiently broadband signal is needed to estimate most of the target's resonant frequencies. Once a set of estimates of the resonance frequencies has been obtained then a template can be formed for future classification purposes. Note that a target's natural resonances are related to its physical size so the largest wavelength that can be expected to probe the target is of the order of 2 to 4 times the size of the target. On the other hand the high

frequencies will excite the higher modes of the resonances but it will be the fundamental resonant frequency which will give the greatest response.

The range profiling method[21] uses high range resolution, and hence large bandwidth, signals to probe the target so that all the major scattering centres of the target can be resolved individually. This creates an image or range profile of the target. From this range profile an estimate of the target's size can be made. Further target information is available if the target can be probed at multiple aspect angles.

A third but related method is the use of impulsive sources (explosions or short pulses) to determine the target strength over a wide band of frequencies[22]. This has the advantage of making several simultaneous frequency measurements in the one operation. By treating the target scattering as a linear process, the deconvolution of a transmit-echo pair of waveforms gives a broadband target impulse response which characterizes the target. Note that the impulse response, or its transfer function equivalent in the frequency domain, is also a function of target aspect angle and tilt angle. So a more complete characterization of the target requires impulse response measurements to be made over a number of these angles. Once a library of transfer functions has been established potential targets can be classified accordingly. In addition, the impulse response can be used to simulate target echoes for any given input waveform by convolution.

6. Conclusions

The basic motivation for using broadband sonar is to improve the range resolution capabilities without sacrificing the detection performance, which is governed by the amount of received energy from the target. This can be achieved by increasing the bandwidth of the signals used. From this improvement in range resolution, a number of other desirable features follow:

- better range accuracy
- improved minimum range of detection
- greater gains in the signal to noise
- more robust estimates of target parameters
- additional information for target classification
- possibility of multipath resolution
- better Doppler tolerance
- lower probability of signal interception

However, all these features come at a cost in terms of increased signal processing complexity, a departure from the narrowband interpretation of measurements and the possible limitations in the maximum detectable range and useable frequency bands imposed by the operating environment.

Future directions for broadband active sonar research are expected to continue in the areas of signal processing where improved detection, tracking and classification performance in highly reverberant environments can come from the development of tools such as the broadband ambiguity function, wavelet techniques and higher-order spectral methods (for coloured Gaussian and non-Gaussian interferences). Implementation of beamforming and pulse compression techniques will continue to attract interest with the emergence of extremely fast FFT and digital signal processing microtechnology. Outside of the signal processing domain, work is needed to improve the modelling of broadband acoustic propagation in terms of computational speed and accuracy. In closing, it is clear that the underlying theme which connects and drives much of this work is waveform design.

7. References

1. The attenuation of the signal's amplitude is generally a function of range and frequency. In a lossless homogeneous medium the intensity of an acoustic signal undergoes spherical spreading, i.e., the intensity falls inversely with the square of the distance. This sort of behaviour can be found in deep water environments. In instances where there exists a surface duct or deep sound channel the signal undergoes cylindrical spreading so that the intensity goes as the inverse of the distance. Further details can be found in
R. J. Urick, "Principles of Underwater Sound", McGraw-Hill, 1975, and
W. S. Burdic, "Underwater Acoustic System Analysis", Prentice-Hall, 1984.
2. H. L. Van Trees, "Detection, Estimation, and Modulation Theory", Part III, Wiley, 1971.
3. Reviews can be found in the "Special Issue on Matched Filters", IRE Trans., IT-6, No. 3, 311, June 1960.
4. Note that an appropriately normalised form of Eq. (11) corresponds to the wavelet transform of $x(t)$ with respect to a given mother wavelet $y(t)$. Further details on the relationship between broadband ambiguity functions and wavelet transforms can be found in, e.g., R. K. Young, "Wavelet Theory and its Applications", Kluwer Academic Publishers 1993. Work on broadband ambiguity functions can be found in:
J. L. Stewart and E. C. Westerfield, "A Theory of Active Sonar Detection", Proc. IRE. 872, May 1959;
E. J. Kelly and R. P. Wishner, "Matched-Filter Theory for High-velocity Targets", IEEE Trans. Military Elect., 9, 56, 1965;
J. M. Speiser, "Wideband Ambiguity Functions", IEEE Trans. on Info. Theory, 122, 1967;

T. H. Glisson, C. I. Black and A. P. Page, "On Digital Replica Correlation Algorithms with Applications to Active Sonar", *IEEE Trans. Audio and Elect.*, 17(3), 190, September 1969;

R. A. Altes, "Some Invariance Properties of the Wideband Ambiguity Function", *J. Acoust. Soc. Am.*, 53, 1154, 1973;

L. H. Sibul and E. L. Titlebaum, "Volume Properties for the Wideband Ambiguity Function", *IEEE Trans. Aero. Elect. Sys.*, AES-17, 83, January 1981.

Further reviews of Wavelets and other related time-frequency transforms can be found in, e.g.,

O. Rioul and M. Vetterli, "Wavelets and Signal Processing", *IEEE Sig. Proc. Magazine*, 14, October 1991;

F. Hlawatsch and G. F. Boudreaux-Bartels, "Linear and Quadratic Time-Frequency Signal Representations", *IEEE Sig. Proc. Magazine*, 21 April 1992.

5. A detailed treatment is given by C. E. Cook and M. Bernfeld, "Radar Signals", Academic Press, 1967. A summary and catalogue of ambiguity functions can be found in G. W. Deley, "Waveform Design", Ch. 3 of "Radar Handbook", Ed. M. I. Skolnik, McGraw-Hill, 1970.
6. C. E. Cook, "Pulse Compression - Key to More Efficient Radar Transmission", *Proc. IRE.* 48, 310, March 1960;
 H. O. Ramp and E. R. Wingrove, "Principles of Pulse Compression", *IRE Trans. MIL-5*, 109, April 1961;
 R. C. Thor, "A Large Time-bandwidth Product Pulse-Compression Technique", *IEEE Trans. MIL-6*, 169, April, 1962.
 E. C. Farnett, T. B. Howard and G. H. Stevens, "Pulse Compression", Ch. 20 of "Radar Handbook", Ed. M. I. Skolnik, McGraw-Hill, 1970.
7. R. H. Barker, "Group Synchronizing of Binary Digital Systems", in "Communication Theory", W. Jackson (Ed.), p. 273, Academic Press, 1953;
 S. W. Golomb and R. A. Scholtz, "Generalized Barker Sequences", *IEEE Trans. Info. Th.* IT-11, 533, October 1965;
 E. C. Farnett et al., in Ref. [6].
8. See, for example, R. C. Dixon, "Spread Spectrum Systems", 2nd Ed., Wiley, 1984.
9. H. F. Harmuth, "Nonsinusoidal Waves for Radar and Radio Communication", in *Advances in Electronics and Electron Physics*, Supl. 14, Academic Press 1981;
 H. F. Harmuth, "Antennas and Waveguides for Nonsinusoidal Waves", in *Advances in Electronics and Electron Physics*, Supl. 15, Academic Press 1984;
 M. G. M. Hussain, "Antenna Patterns of Nonsinusoidal Waves with the Time Variation of a Gaussian Pulse", Parts I and II, *IEEE Trans. Elect. Compat.*, 30, 504, November 1988.

10. X. Lurton and S. Coatelan, "Array Directivity for Wideband Signals: A Time-domain Approach", European Conference on Underwater Acoustics, Ed., M. Weydert, p. 721, Elsevier Science 1992.
11. The spatial distribution of correlatable energy is obtained by correlating the output waveform of the beamformer at a given angle (from broadside) with that of a reference waveform. This reference is usually the waveform obtained when the received signal comes from the broadside direction. Further details can be found in J. Doss Halsey, "Array Antenna Calculations in the Time Domain using Pseudorandomly coded Signals", in "Introduction to Ultra-Wideband Radar Systems", Ed., J. D. Taylor, p. 216, CRC Press 1995.
12. Similar formulations of a broadband beamformer were also considered in R. F. Follett and J. P. Donohoe, "A Wideband, High-Resolution, Low-Probability-of-Detection FFT Beamformer", IEEE J. Oceanic Eng., 19, No. 2, 175, April 1994;
 R. S. Walker, A. T. Ashley and P. F. Kavanagh, "Noise Normalization of Broadband Sonar Data in Bearing Space", Proc. IEEE Int. Conf. on ASSP, p. 375, April 1983;
 M. E. Weber and R. Heisler, "A Frequency-domain Beamforming Algorithm for Wideband, Coherent Signal Processing", J. Acoust. Soc. Am., 76, 1132, 1984;
 B. D. Van Veen and K. M. Buckley, "Beamforming: A Versatile Approach to Spatial Filtering", IEEE ASSP Magazine, 4, April 1988;
 C. Liu and S. Sideman, "Digital Frequency-domain Implementation of Optimum Broadband Arrays", J. Acoust. Soc. Am., 98, 241, 1995;
 L. C. Godara, "Application of the Fast Fourier Transform to Broadband Beamforming", J. Acoust. Soc. Am., 98, 230, 1995.
13. D. G. Tucker, "Arrays with Constant Beamwidth over a Wide Frequency Range", Nature 180, 496, 1957;
 J. C. Morris, "Broadband Constant Beamwidth Transducers", J. Sound and Vibration, 1, 28, 1964;
 R. P. Smith, "Constant Beamwidth Receiving Arrays for Broadband Sonar Systems", Acustica, 23, 21, 1970;
 P. H. Rogers and A. L. Van Buren, "New Approach to a Constant Beamwidth Transducer", J. Acoust. Soc. Am. 64, 38, 1978;
 J. Lardies and J.-P. Guilhot, "A Very Wide Bandwidth Constant Beamwidth Acoustical End-fire Line Array Without Sidelobes", J. Sound and Vibration, 120, 557, 1988;
 R. Bel, M. E. Zakharia and O. Blazere, "Sonar Arrays with Constant Directivity over a Wide Frequency Range", European Conference on Underwater Acoustics, Ed., M. Weydert, p. 725, Elsevier Science 1992.
14. See Urick or Burdic in Ref. [1].

15. F. B. Jensen, "Wave Theory Modeling: A Convenient Approach to CW and Pulse Propagation Modeling in Low-Frequency Acoustics", *IEEE J. Oceanic Eng.*, 13, 186, Oct 1988.
16. A summary of wave propagation models for underwater acoustics can be found in P. C. Etter, "Underwater Acoustic Modeling: Principles, Techniques and Applications", p. 83, Elsevier 1991.
17. D. E. Kerr (ed.), "Propagation of Short Radio Waves", MIT Radiation Lab Series, Vol. 13, McGraw-Hill 1951.
18. R. F. Henrick, J. R. Brannan, D. B. Warmer and G. P. Formey, "The Uniform WKB Modal Approach to Pulsed and Broadband Propagation", *J. Acoust. Soc. Am.*, 74, 1464, 1983;
 Jensen in Ref. [15];
 L. Boden, J. B. Bowlin and J. L. Spiesberger, "Time Domain Analysis of Normal Mode, Parabolic and Ray Solution of Wave Equation", *J. Acoust. Soc. Am.*, 90, 954, 1991;
 R. Zhang and Y. He, "Long Range Pulse Propagation in Ocean Channels", *J. Sound and Vibration*, 179, 313, 1995.
19. J. E. Murphy, "Finite-difference Treatment of Time-domain Parabolic Equation Theory", *J. Acoust. Soc. Am.*, 77, 1958, 1985;
 B. E. McDonald and W. A. Kuperman, "Time Domain Formulation for Pulse Propagation Including Nonlinear Behaviour Near a Caustic", *J. Acoust. Soc. Am.*, 81, 1406, 1987;
 M. D. Collins, "The Time-domain Solution of Wide-angular Parabolic Equation including the Effects of Sediment Dispersion", *J. Acoust. Soc. Am.*, 84, 2114, 1988 and "Applications and Time-domain Solution of High-order Parabolic Equation in Underwater Acoustics", *J. Acoust. Soc. Am.*, 86, 1097, 1989;
 B. J. Orchard, W. L. Siegmann and M. J. Jacobson, "Three-dimensional Time-domain Paraxial Approximations for Ocean Acoustic Wave Propagation", *J. Acoust. Soc. Am.*, 91, 788, 1992.
20. E. M. Kennaugh and D. L. Moffatt, "Transient and Impulse Response Approximations", *Proc. IEEE*, 53, 893, August 1965;
 A. A. Ksienski, Y. T. Lin and L. J. White, "Low Frequency Approach to Target Identification", *Proc. IEEE*, 63, 1651, December 1975;
 D. Guicking, K. Gork and H. Peine, "Classification of Underwater Objects using Resonance Scattering and Neural Networks", *European Conference on Underwater Acoustics*, Ed., M. Weydert, p. 567, Elsevier Science 1992.
21. H. J. Li and S. H. Young, "Using Range Profiles as Feature Vectors to Identify Aerospace Objects", *IEEE Trans. Antennas and Propagation*, 41, 261, March 1993;

- S. Hudson and D. Psaltis, "Correlation Filters for Aircraft Identification from Radar Range Profiles", IEEE Trans. Aero. Elect. Sys., AES-29, 741, July 1993;
- A. Zyweck and R. E. Bogner, "Radar Target Classification of Commercial Aircraft", IEEE Trans. Aero. Elect. Sys., AES-31, 277, October 1995.
22. M. A. Cosgrove, "Wideband Target Strength Measurements", IEEE Int. Conf. on ASSP, p. 679, 1976.

8. Appendix

The Analytic Signal Model

Consider the following signal representation

$$s(t) = \text{Re}\{\mu(t)\} = \text{Re}\{a(t) \exp(j2\pi f_c t)\}. \quad (\text{A1})$$

In terms of its Fourier Transform, $S(f)$, Eq. (A1) can be written as

$$\begin{aligned} s(t) &= \int_{-\infty}^{\infty} S(f) \exp(j2\pi ft) df \\ &= \int_0^{\infty} S(f) \exp(j2\pi ft) df + \int_0^{\infty} S(-f) \exp(-j2\pi ft) df \quad (\text{A2}) \\ &= 2 \text{Re}\left\{ \int_0^{\infty} S(f) \exp(j2\pi ft) df \right\} \end{aligned}$$

where the property, $S^*(f) = S(-f)$ for a real signal $s(t)$, was used. By comparing Eqs. (A1) and (A2), the complex representation is given by

$$\mu(t) = \int_0^{\infty} 2S(f) \exp(j2\pi ft) df \quad (\text{A3})$$

which implies that the spectrum of $\mu(t)$ does not have any negative frequencies. If $\mu(t)$ did have negative frequencies then $\text{Re}\{\mu(t)\}$ would not be a valid representation of $s(t)$.

DISTRIBUTION LIST

Broadband Active Sonar: Implications and Constraints

H. Lew

AUSTRALIA

1. DEFENCE ORGANISATION

a. **Task Sponsor** Director General Force Development (Sea)

b. **S&T Program**

Chief Defence Scientist

FAS Science Policy

AS Science Industry and External Relations

AS Science Corporate Management

Counsellor Defence Science, London (Doc Data Sheet)

Counsellor Defence Science, Washington (Doc Data Sheet)

Scientific Adviser to MRDC Thailand (Doc Data Sheet)

Director General Scientific Advisers and Trials/Scientific Adviser Policy and Command (shared copy)

Navy Scientific Adviser

Scientific Adviser - Army (Doc Data Sheet and distribution list only)

Air Force Scientific Adviser

Director Trials

} shared copy

Aeronautical and Maritime Research Laboratory

Director

Electronics and Surveillance Research Laboratory

Director

Chief of Maritime Operations Division

R. Barrett, RLSTP MOD Salisbury

G. Furnell, MOD Salisbury

A. Jones, MOD Salisbury

L. Kelly, MOD Salisbury

A. Larsson, MOD Salisbury

H. Lew, MOD Salisbury

D. Liebing, MOD Salisbury

D. McMahon, MOD Salisbury

J. Riley, MOD Salisbury

D. Sweet, MOD Salisbury

S. Taylor, MOD Salisbury

DSTO Library

Library Fishermens Bend

Library Maribyrrong

Library DSTOS (2 copies)

Australian Archives

Library, MOD, Pyrmont (Doc Data sheet only)

c. Forces Executive

Director General Force Development (Land) (Doc Data Sheet only)
Director General Force Development (Air) (Doc Data Sheet only)

d. Navy

SO (Science), Director of Naval Warfare, Maritime Headquarters Annex, Garden Island, NSW 2000. (Doc Data Sheet only)

e. Army

ABCA Office, G-1-34, Russell Offices, Canberra (4 copies)

g. S&I Program

Defence Intelligence Organisation
Library, Defence Signals Directorate (Doc Data Sheet only)

i. B&M Program (libraries)

OIC TRS, Defence Central Library
Officer in Charge, Document Exchange Centre (DEC), 1 copy
*US Defence Technical Information Centre, 2 copies
*UK Defence Research Information Center, 2 copies
*Canada Defence Scientific Information Service, 1 copy
*NZ Defence Information Centre, 1 copy
National Library of Australia, 1 copy

2. UNIVERSITIES AND COLLEGES

Australian Defence Force Academy
Library
Head of Aerospace and Mechanical Engineering
Deakin University, Serials Section (M list), Deakin University Library, Geelong, 3217
Senior Librarian, Hargrave Library, Monash University
Librarian, Flinders University

3. OTHER ORGANISATIONS

NASA (Canberra)
AGPS

OUTSIDE AUSTRALIA

4. ABSTRACTING AND INFORMATION ORGANISATIONS

INSPEC: Acquisitions Section Institution of Electrical Engineers
Library, Chemical Abstracts Reference Service
Engineering Societies Library, US
American Society for Metals
Documents Librarian, The Center for Research Libraries, US

5. INFORMATION EXCHANGE AGREEMENT PARTNERS

Acquisitions Unit, Science Reference and Information Service, UK
Library - Exchange Desk, National Institute of Standards and Technology, US

SPARES (10 copies)

Total number of copies: 64

DEFENCE SCIENCE AND TECHNOLOGY ORGANISATION DOCUMENT CONTROL DATA				1. PRIVACY MARKING/CAVEAT (OF DOCUMENT)	
2. TITLE Broadband Active Sonar: Implications and Constraints			3. SECURITY CLASSIFICATION (FOR UNCLASSIFIED REPORTS THAT ARE LIMITED RELEASE USE (L) NEXT TO DOCUMENT CLASSIFICATION) Document (U) Title (U) Abstract (U)		
4. AUTHOR(S) H. Lew			5. CORPORATE AUTHOR Aeronautical and Maritime Research Laboratory PO Box 4331 Melbourne Vic 3001		
6a. DSTO NUMBER DSTO-TR-0435		6b. AR NUMBER AR-009-916	6c. TYPE OF REPORT Technical Report		7. DOCUMENT DATE October 1996
8. FILE NUMBER 510/207/0530	9. TASK NUMBER ADS 96/083	10. TASK SPONSOR DGFD (SEA)	11. NO. OF PAGES 29		12. NO. OF REFERENCES 22
13. DOWNGRADING/DELIMITING INSTRUCTIONS None			14. RELEASE AUTHORITY Chief, Maritime Operations Division		
15. SECONDARY RELEASE STATEMENT OF THIS DOCUMENT <i>Approved for public release</i>					
OVERSEAS ENQUIRIES OUTSIDE STATED LIMITATIONS SHOULD BE REFERRED THROUGH DOCUMENT EXCHANGE CENTRE, DIS NETWORK OFFICE, DEPT OF DEFENCE, CAMPBELL PARK OFFICES, CANBERRA ACT 2600					
16. DELIBERATE ANNOUNCEMENT No limitations					
17. CASUAL ANNOUNCEMENT Yes					
18. DEFTEST DESCRIPTORS Active Sonar; Broadband; Signal Processing; Underwater Acoustics					
19. ABSTRACT The broadband sonar concept has an impact on all areas of an active sonar system. This includes the signal processing of transmit-receive signals, the response of the medium and the target response. Beginning with the definition of a broadband signal, the implications of broadband signal processing in terms of matched filtering, pulse compression, low probability of interception and beamforming are examined. This is followed by an investigation of the constraints imposed on the propagation of broadband signals by the medium. Finally, a brief discussion on the use of broadband techniques for target classification concludes the report.					