

O

F

S

D

AR-009-909

DSTO-TN-0060

Sensitivity Study of an AMRL
Finite Element Model of the
F-111 Lower Wing Skin Structural
Detail at Forward Auxiliary Spar
Station (FASS) 281.28

D. Keeley, R. Callinan
and S. Sanderson

DTIC QUALITY INSPECTED 4

APPROVED FOR PUBLIC RELEASE

© Commonwealth of Australia

19970307 020

DEPARTMENT OF DEFENCE
DEFENCE SCIENCE AND TECHNOLOGY ORGANISATION

100-30

THE UNITED STATES NATIONAL
TECHNICAL INFORMATION SERVICE
IS AUTHORIZED TO
REPRODUCE AND SELL THIS REPORT

Sensitivity Study of an AMRL Finite Element Model of the F-111 Lower Wing Skin Structural Detail at Forward Auxiliary Spar Station (FASS) 281.28

D. Keeley, R. Callinan and S. Sanderson

**Airframes and Engines Division
Aeronautical and Maritime Research Laboratory**

DSTO-TN-0060

ABSTRACT

A baseline three-dimensional Finite Element (FE) model has been developed for a structural detail on an F-111 lower wing skin at Forward Auxiliary Spar Station (FASS) 281.28. This location has been the site of cracking in both RAAF and USAF aircraft. The FE model was developed using precise thickness measurements appropriate for a specific full-scale test wing available at AMRL (serial number A-10-824). This document is a sensitivity study of the finite element model. The effects of small dimensional changes falling within the range of the manufacturing tolerances are investigated. This will allow a quantitative assessment of the stress variations which could be expected at that location within the F-111 fleet.

RELEASE LIMITATION

Approved for public release

D E P A R T M E N T O F D E F E N C E

DEFENCE SCIENCE AND TECHNOLOGY ORGANISATION

Published by

*DSTO Aeronautical and Maritime Research Laboratory
PO Box 4331
Melbourne Victoria 3001*

*Telephone: (03) 9626 8111
Fax: (03) 9626 8999
© Commonwealth of Australia 1996
AR No. AR-009-909
September 1996*

APPROVED FOR PUBLIC RELEASE

Sensitivity Study of an AMRL Finite Element Model of the F-111 Lower Wing Skin Structural Detail at Forward Auxiliary Spar Station (FASS) 281.28

Executive Summary

A baseline three-dimensional Finite Element (FE) model has been developed for a structural detail on an F-111 lower wing skin at Forward Auxiliary Spar Station (FASS) 281.28. This location has been the site of cracking in both RAAF and USAF aircraft. The FE model was developed using precise thickness measurements appropriate for a specific full scale test wing (serial number A10-824) available at AMRL. This report documents an investigation into the sensitivity of the FE model to small changes in the local geometry. The effects of geometry extremes within the range of manufacturing tolerances are investigated. Parameters investigated include skin thickness, the fillet radii around the fuel-flow passage, and the effectiveness of the skin to spar fasteners. The most sensitive parameter was found to be the skin thickness. Consequently, it has been recommended to the RAAF that non-destructive in-situ measurements of the local skin thickness at this critical location on all RAAF F-111 aircraft would provide a useful indication of susceptibility to cracking.

Contents

| | |
|--|----|
| 1. INTRODUCTION | 1 |
| 2. THICKNESS SENSITIVITY..... | 2 |
| 2.1 Drawing specifications..... | 2 |
| 2.2 Test wing dimensions..... | 2 |
| 2.3 Finite element model | 2 |
| 2.4 Sensitivity range | 3 |
| 3. RADII SENSITIVITY | 3 |
| 3.1 Drawing specifications..... | 3 |
| 3.2 Measured radii | 3 |
| 3.3 Finite Element model..... | 3 |
| 3.4 Range selected | 4 |
| 4. EFFECTIVE BOLT CLAMPING RADIUS..... | 4 |
| 4.1 Definition..... | 4 |
| 4.1.1 Actual wing | 4 |
| 4.1.2 Finite Element Model..... | 5 |
| 4.2 Sensitivity range | 6 |
| 5. DISCUSSION..... | 6 |
| 5.1 Thickness sensitivity..... | 6 |
| 5.2 Radii sensitivity | 7 |
| 5.3 Effective bolt clamping radius (EBCR)..... | 8 |
| 6. CONCLUSION..... | 9 |
| 6.1 Wing skin thickness | 9 |
| 6.2 Wing skin radii..... | 9 |
| 6.3 Effective bolt clamping radius | 9 |
| 7. ACKNOWLEDGMENTS | 10 |
| 8. REFERENCES | 10 |
| APPENDICES..... | 11 |

List of Abbreviations

| | |
|------|---|
| AMRL | Aeronautical and Maritime Research Laboratory |
| CPLT | Cold Proof Load Test |
| EBCR | Effective Bolt Clamping radius |
| FAS | Forward Auxiliary Spar |
| FASS | Forward Auxiliary Spar Station |
| FE | Finite Element |
| FEM | Finite Element Model |
| FFP | Fuel-Flow Passage |
| RAAF | Royal Australian Air force |
| USAF | United States Air Force |

1. Introduction

The discovery of a 48 mm chordwise fatigue crack at a fuel-flow passage at Forward Auxiliary Spar Station (FASS) 281.28 in the lower wing skin of a RAAF F-111C aircraft (Tail Number A8-145) has led to the use of an adhesively bonded patch repair. A similar crack had also been discovered in the wing of a USAF F-111G aircraft. A series of Finite Element (FE) models of the local region indicated in figure 1 has been developed, as part of a comprehensive repair-substantiation program being undertaken by AMRL for a RAAF-designed bonded composite repair for this cracking. Detailed thickness measurements undertaken on a full-scale wing available at AMRL (ex-USAF F-111A, serial no: A-10-824) were used to create a baseline FE model, as detailed in [1]. This model was validated and calibrated by comparing the FE results with experimental strain-gauge data obtained from a strain survey undertaken on that wing.

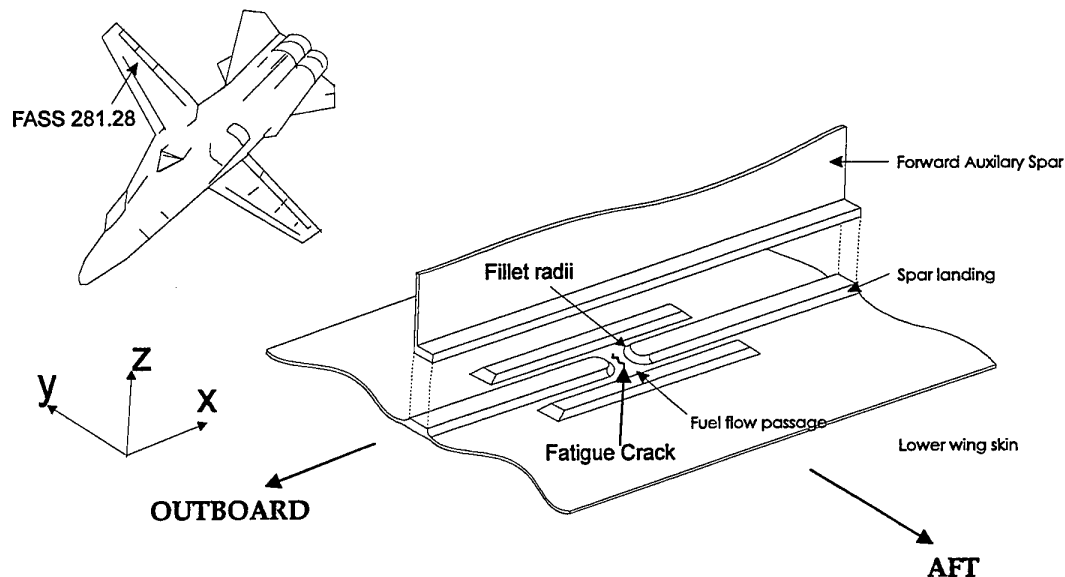

Figure 1. Fuel-flow passage

Portable hand routers are used in the final manufacturing process of the Fuel-Flow-Passage (FFP) [2]. This has led to significant variations in local geometry. It was found through ultrasound thickness measurements [3] that the actual thickness of the test wing was outside the engineering drawing specifications [4] (approximately 12 per cent increase). Due to the relatively small dimensions associated in the fuel-flow area, this small geometry change had a significant effect on the strain distribution surrounding the crack site.

Along with the wing skin thickness, variations in the fillet radii and the assumed spar contact area on the spar landing were also found to affect the strain distribution at the FFP in the FE model. This report documents the effect of small changes to these three parameters. To minimise run time, no coupling of the varied parameters was considered.

2. Thickness Sensitivity

The total stress at the FFP is a combination of bending and tensile load. The neutral axis offset between the wing skin and the spar landing produces the localised bending stress. The tensile load is derived from the entire wing bending. Both stresses are proportional to the wing skin thickness. Because of the relatively thin wing skin (nominally 3.7 mm), small variations of even half a millimetre can create a large percentage change in the thickness. These small variations can be created from the manufacturing process. The test wing for example has an average wing skin thickness of 4.19 mm, whereas the skin thickness on the cracked F-111G wing is 3.3 mm. This section documents the effect of expected thickness variations within the F-111 fleet on the stress and strain fields at the FFP.

2.1 Drawing specifications

The manufacture of the F-111 including the wings, is outlined in [2]. Drawing specifications allow a wing skin thickness of 0.143 ± 0.010 inches (3.6 ± 0.2 mm) [4].

2.2 Test wing dimensions

Ultrasound testing of the F-111A test wing skin indicated a thickness of 0.163 ± 0.007 inches (4.15 ± 0.17 mm) at the centre of the FFP [3].

2.3 Finite element model

The finite element model documented in [1], assumes a constant skin thickness of 4.3 mm (0.169 inches). This value corresponds to the average wing skin thickness for the test wing at the FFP. The skin thickness in the critical region at the centre of the fuel flow passage is approximately 4.2 mm (0.165 inches) and the skin thickness variations described in this report refer to changes in the skin thickness in the critical region.

2.4 Sensitivity range

The present investigation into wing-skin thickness sensitivity uses FE results for wing skin thicknesses ranging from 3.6 mm to 4.2 mm. These values correspond respectively to the minimum acceptable thickness, according to the design specifications, and the actual skin thickness measured on the A-10-824 test wing. The chordwise strain distribution results for different wing skin thicknesses at CPLT loading are shown in Appendix A.

3. Radii Sensitivity

As far back as Wöhler's experiments on railway axle failures [5], the radii at step downs have been recognised as an important parameter in fatigue fracture mechanics. The stress concentration at the fuel-flow passage is closely bounded by two spar-landing step downs or fillets. The engineering design drawings for the F-111 wing specify a fillet radii design tolerance of approximately five percent at the FFP [4]. These tolerances were designed to allow for small geometry variations in the manufacture of the wing skin. This section documents the influence of fillet radius variations within design tolerances on the stress and strain distribution at the FFP.

3.1 Drawing specifications

The General Dynamics drawing specifications defined the fillet radii dimensions at the FFP as 0.38 ± 0.024 inches (9.6 ± 0.6 mm) [4].

3.2 Measured radii

A polyether mould of the fuel-flow passage was taken from the test wing. Approximate radii measurements placed the fillet radii at between 8 mm and 10 mm [6].

3.3 Finite Element model

Due to the range of fillet radii measurements, a radius of 9.6 mm was selected for the FE model fillets. This value corresponds to the drawing specifications, and is within the measured radii range.

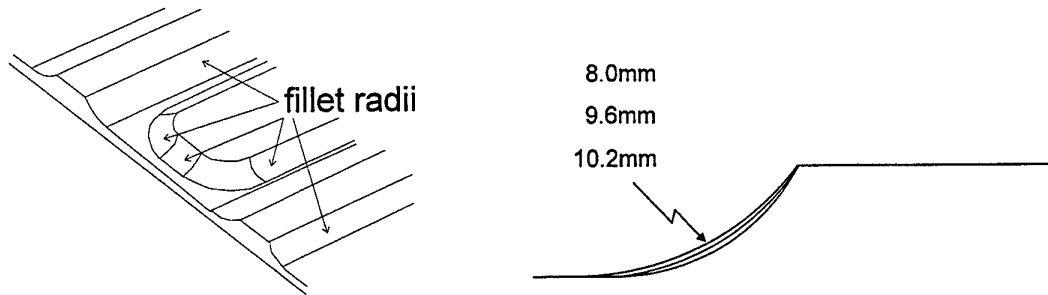

Figure 2. Range of selected radii

3.4 Range selected

To investigate the sensitivity of fillet radii variations, results for radii between 8.0 and 10.2 mm were obtained. These radii represent the maximum and minimum values of the measured and designed fillet radii at the FFP. Results for stress, strain and the deformed shape at the FFP are shown in Appendix B for CPLT loading.

4. Effective bolt clamping radius

The method of fastening the spar to the spar landing in the FE model influences the amount of support transferred from the spar to the wing skin, which in turn influences the stress distribution at the FFP. The amount of the spar fastened to the spar landing is based on an effective bolt clamping area [7]. An area of adjoining nodes on the spar cap and spar landing are collapsed onto each other along most of the length of the landing. Gap elements are inserted between the spar cap and spar landing in the remaining area between the bolt centres bridging the fuel flow passage. This allows the skin and spar landing to bend independent of the spar cap hence allowing variations to the FE stress strain distribution. This section documents the effect of reasonable variations of the effective bolt clamping area on the stress and strain distributions at the FFP.

4.1 Definition

4.1.1 Actual wing

For the actual wing, a circular area can be used to approximate the clamping zone as shown in figure 3. The Effective Bolt Clamping Radius (EBCR) is used as a geometry parameter.

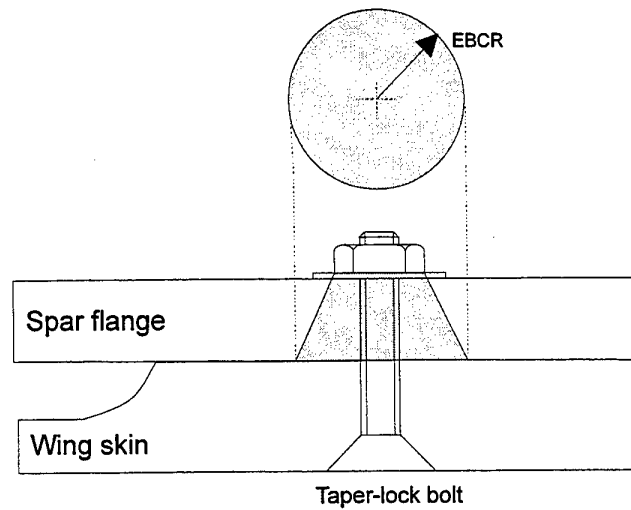

Figure 3. Definition of EBCR

As the wing deforms the shape of the effective bolt clamping zone will change. Due to the localised bending, the largest deformation of the FE model spar landing occurs at the FFP. It is therefore assumed that the EBCR closest to the passage will exhibit a larger variation than at the other bolt locations.

4.1.2 Finite Element Model

The FE model bolt clamping zone is assumed to be modelled as a rectangular area of nodes joined to the spar and spar landing. This is shown in figure 4.

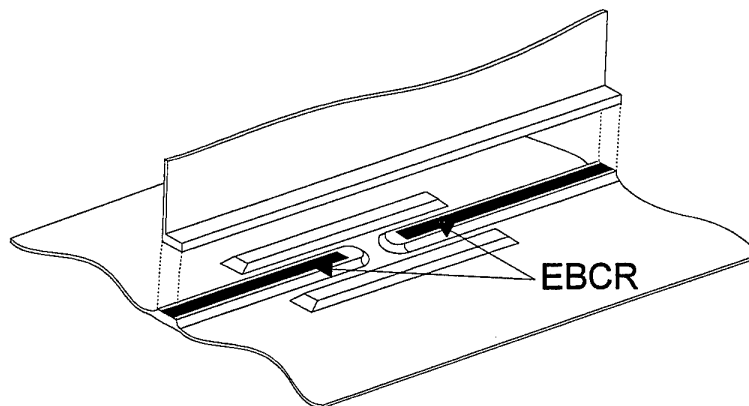

Figure 4. FE definition of EBCR

As shown by figure 5 below, when the value of the EBCR is increased, the width and length of the rectangle increases with respect to the centre of the actual bolt location closest to the FFP.

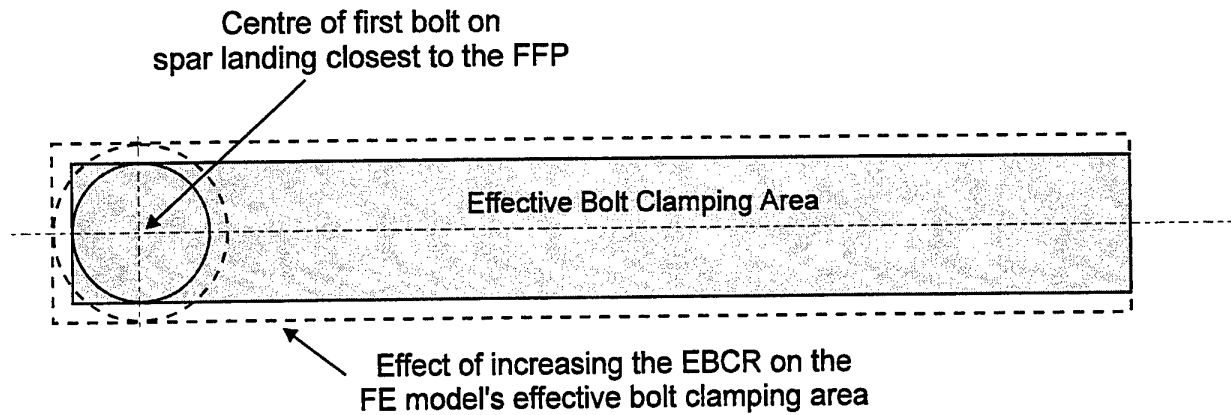

Figure 5. Effect of varying the EBCR to FE model effective bolt clamping area

4.2 Sensitivity range

The minimum chosen EBCR value was that of the taper-lock fastener shank diameter (6.5 mm). A selection of bolt clamping radii were chosen arbitrarily. The strain results at CPLT loading are compared in Appendix C.

5. Discussion

5.1 Thickness sensitivity

The results shown in Appendix A indicate that a change in wing skin thickness produces a shift in the FE strains. As shown in the following equation, the total stress is a combination of tensile load and bending:

$$\sigma_{xx} = \frac{F}{A} + \frac{My}{I}$$

As the cross-sectional area "A" decreases, the tensile stress increases for the same applied force. At the FFP, as the wing skin thickness decreases, the neutral axis offset becomes larger producing a larger bending moment "M", and the magnitude of the second moment of area "I" decreases. These changes increase the magnitude of the bending stress. The net result is an increase in the magnitude of the total stress on the

inside surface (in tension), and a lesser increase in magnitude on the outside surface. Assuming linear elasticity, the strain is directly proportional to stress, and thus would follow the same trend.

The wing skin thicknesses for the FE models used in the sensitivity study were based on the extreme design specifications (3.6 and 3.8 mm), and that of the test wing. The minimum thickness of 3.6 mm is used as it is the most conservative. The maximum percentage decrease in strain within the design tolerances was calculated by the FE model to be 1.4 percent on the outside surface and 8.5 percent on the inside surface of the FFP centre. The test wing FE model, with a wing skin thickness of 4.19 mm, calculated a 15.2 percent decrease in strain on the outside surface and a 32.7 percent decrease on the inside surface compared to the base line 3.6 mm thick wing skin model.

The decrease in the strain due to an increase in wing thickness on the outside surface of the wing skin is not as large as on the inside surface. This can be explained by the large stress decrease caused by the tensile load on the outside surface being only moderately reduced by the compressive bending stress. The magnitude of these strain variations would have a significant influence on the fatigue behaviour.

5.2 Radii sensitivity

Results shown in Appendix B indicate that the fillet radii most sensitive to change is situated on the centreline of the spar landing as shown in figure 5.

As the governing fillet radius is increased, the transition line between edge of the radius and the flat wing skin moves towards the crack line (Appendix B.2). After deformation occurs there is a peak produced on the inside surface of the crack line (Appendix B.3). This is the location of the maximum bending and tensile stress. A second stress concentration is produced at the location of the transitional line. As the radius increases, the effects of both stress concentrations converge (Appendix B.3). The interaction of both stress concentrators leads to an increase in the maximum stress.

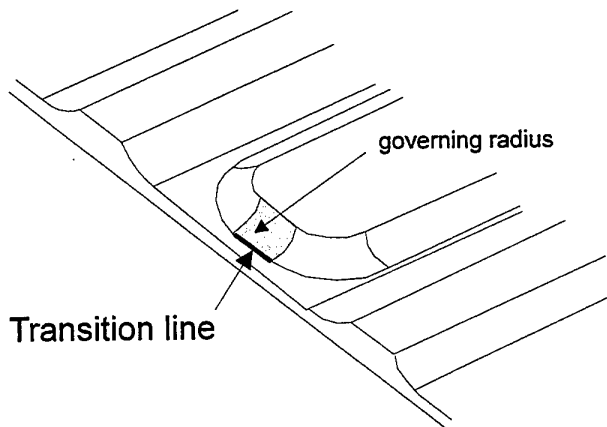

Figure 6. Location of critical radii

5.3 Effective bolt clamping radius (EBCR)

The presence of a spar creates a bending restraint which has an affect on the deformed shape at the FFP as shown in figure 7. The restraining effect varies with EBCR. An increase in EBCR provides more restraint which decreases the radius of curvature observed at the FFP and reduces the secondary bending. This is reflected in the increased value in the minimum strain on the lower surface (Appendix C1). The mechanism for this is that the increased EBCR leaves a shorter spanwise distance across the FFP which may move upwards to accommodate the neutral axis offset between the spar landing and the skin.

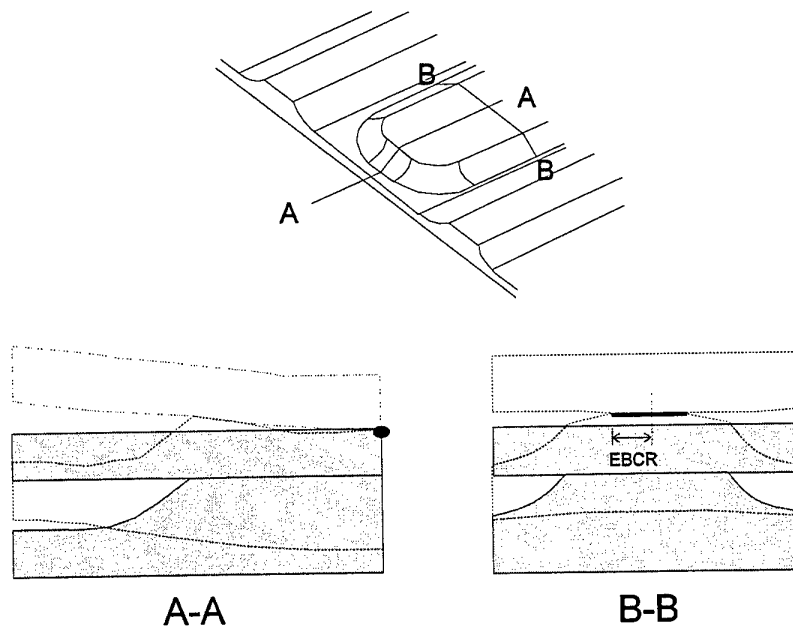

Figure 7. Effect of EBCR on deformed shape

The discrete nature of the EBCR restraint in the FE model creates small stress concentrations around the nodes at the edges of the spar attachment area. However the locations at which calculated strains are examined however are far enough from these stress concentrations so as not to be influenced by them.

As the structure deforms, the spar landing diverges from the spar at the end of the EBCR restraint, as shown in figure 7. The spar landing at the edge of the FFP remains in contact with the spar. Gap elements are used here to allow compressive only load transfer and to prevent the separate structural elements from passing through one another. As the EBCR is increased, the extent of vertical translation and the radius of curvature of the wing skin at the centre of the FFP is reduced. This increases the calculated strains at the FFP with the inside surface increasing by more than the outside surface (Appendix C1 & 2).

6. Conclusion

6.1 Wing skin thickness

The most sensitive parameter investigated was found to be the wing skin thickness. A variation in the wing skin thickness produces a significant strain shift. The thinner the wing skin, the larger the stresses and strains become at the FFP. Based upon these findings, it is recommended that non-destructive in-situ measurements of the local skin thickness at the FFP would provide an indication of the susceptibility to cracking at this location.

6.2 Wing skin radii

A variation in the spar landing fillet radius at the FFP produced a change in the FE stress distribution. A decrease in the fillet radius within the engineering design tolerances, was found to decrease the magnitude and spread of the stress concentration at the FFP.

6.3 Effective bolt clamping radius

A variation of the EBCR was found to affect the stress and strain distribution at the FFP. An increase in EBCR resulted in an increase in bending and therefore stress magnitudes at the crack location.

7. Acknowledgments

The author wishes to acknowledge the assistance and input from Dr. L.R.F. Rose and Messrs K. Walker, and P. Penhall from the Airframes and Engines Division of AMRL.

8. References

- [1] KEELEY, D.W., CALLINAN, R.J. & SANDERSON, S. *A Validated Finite Element Model of an F-111 Lower Wing Skin Structural Detail at Forward Auxiliary Spar Station (FASS) 281.28*. AMRL, Technical note, in preparation.
- [2] McHENRY, H. & KEY, R. (1994) *The F-111 Logic, Familiar Materials; proven processes*. Metal Progress, p62.
- [3] MORTON, H. (1994) *DAFA NDI Report*. NDI/HM/3/94 AMRL.
- [4] GENERAL DYNAMICS DRAWING 12W951
- [5] WÖHLER'S EXPERIMENTS ON THE STRENGTH OF METALS Engineering, August 23 1967, p160
- [6] PENHALL, P. (4/5/1995) RE: F-111C Wing SRO#2 & FFVH-13 surveying SES/52/5/1/02 minute. F-111 Bonded repair task. AMRL
- [7] BANBURY, A., KELLY, D.W. & GUYON J.M. *A Procedure for Finite Element Analysis of Structures Containing Mechanically Fastened Joints* Proceedings First Australian Congress on Applied Mechanics 21-23 February 1996, Melbourne, p121

Appendix A 1

Wing Skin Thickness Sensitivity Study Lower surface

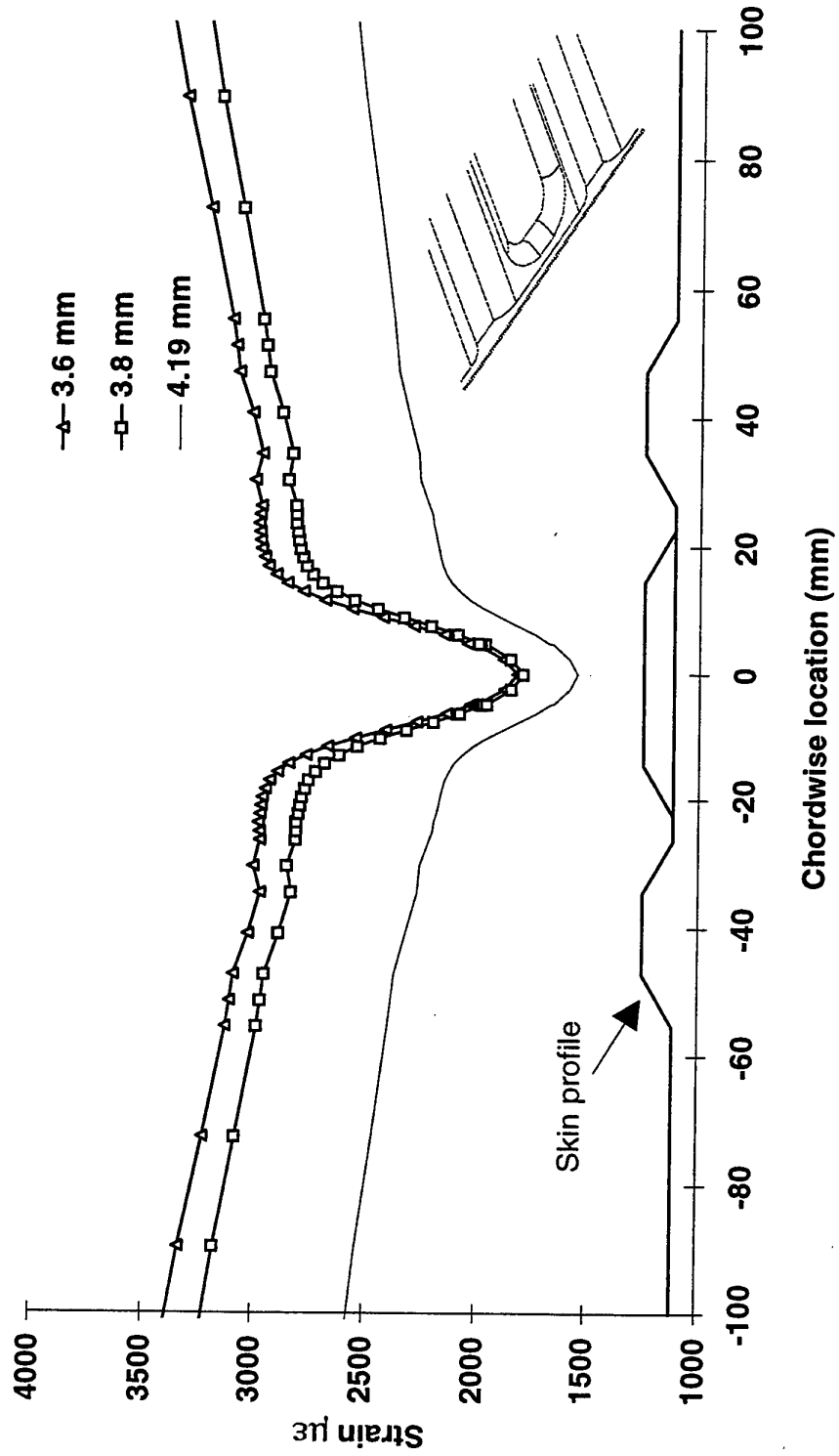

Appendix A 2

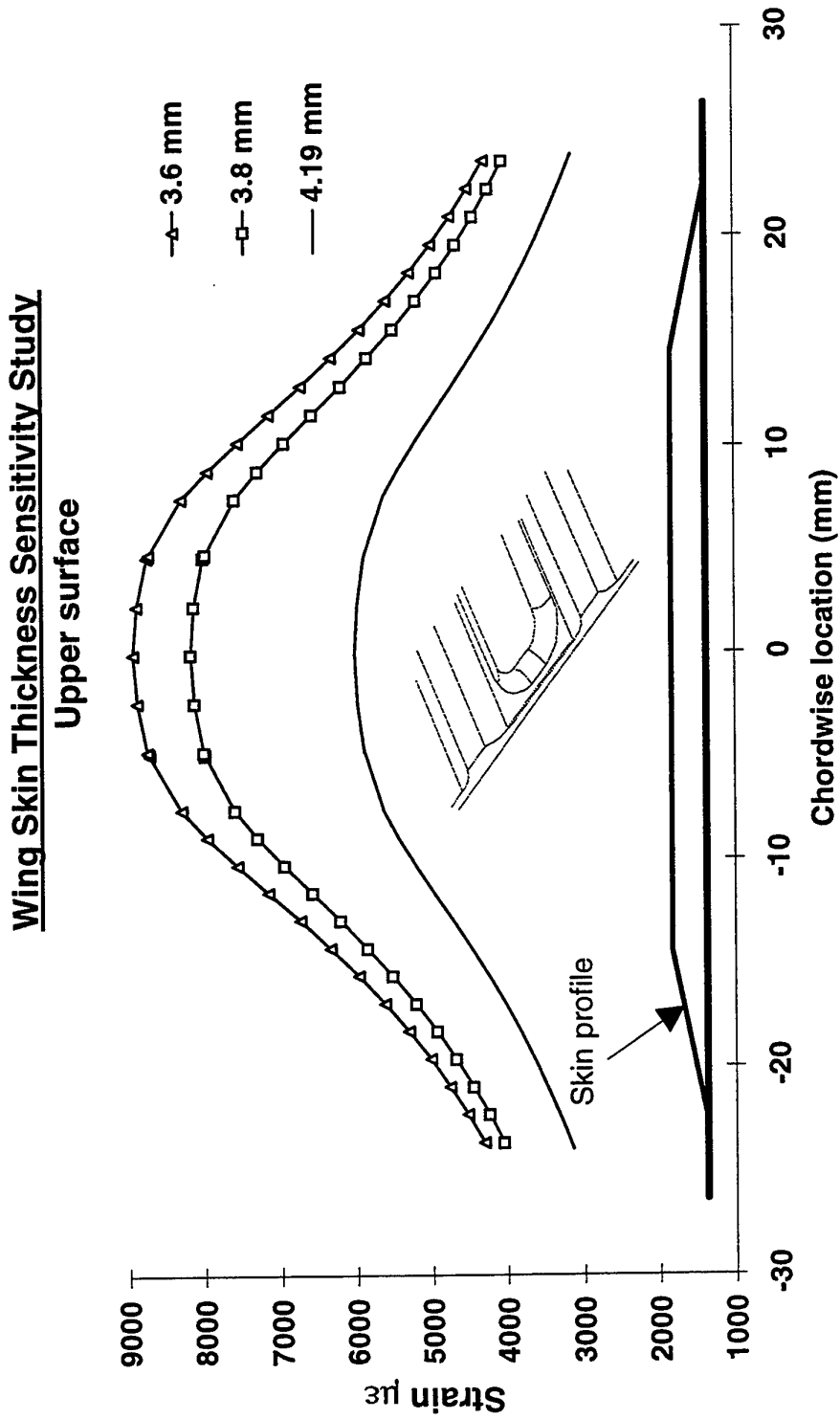

Appendix B 1.1

Fillet Radii Sensitivity Study Lower surface

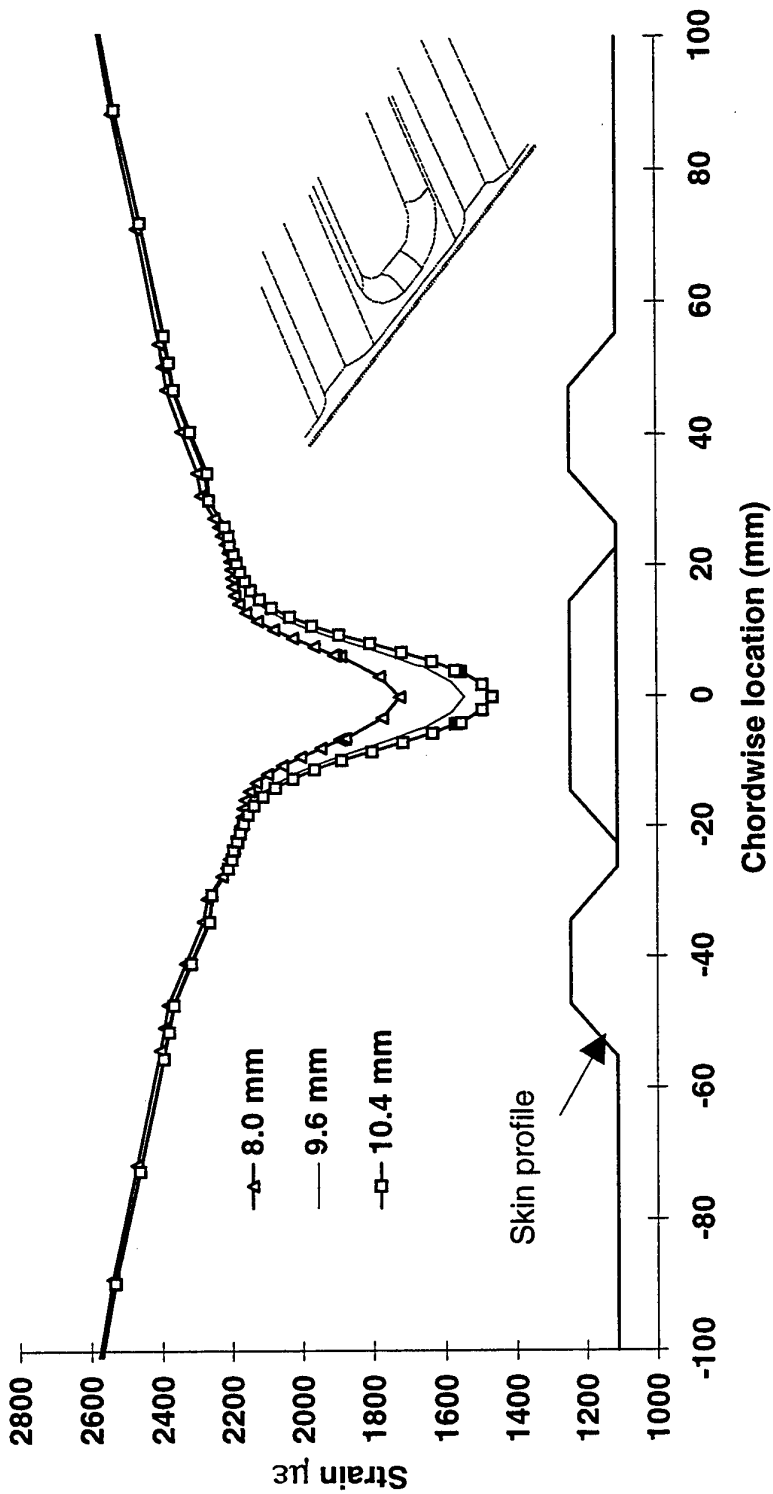

Appendix B 1.2

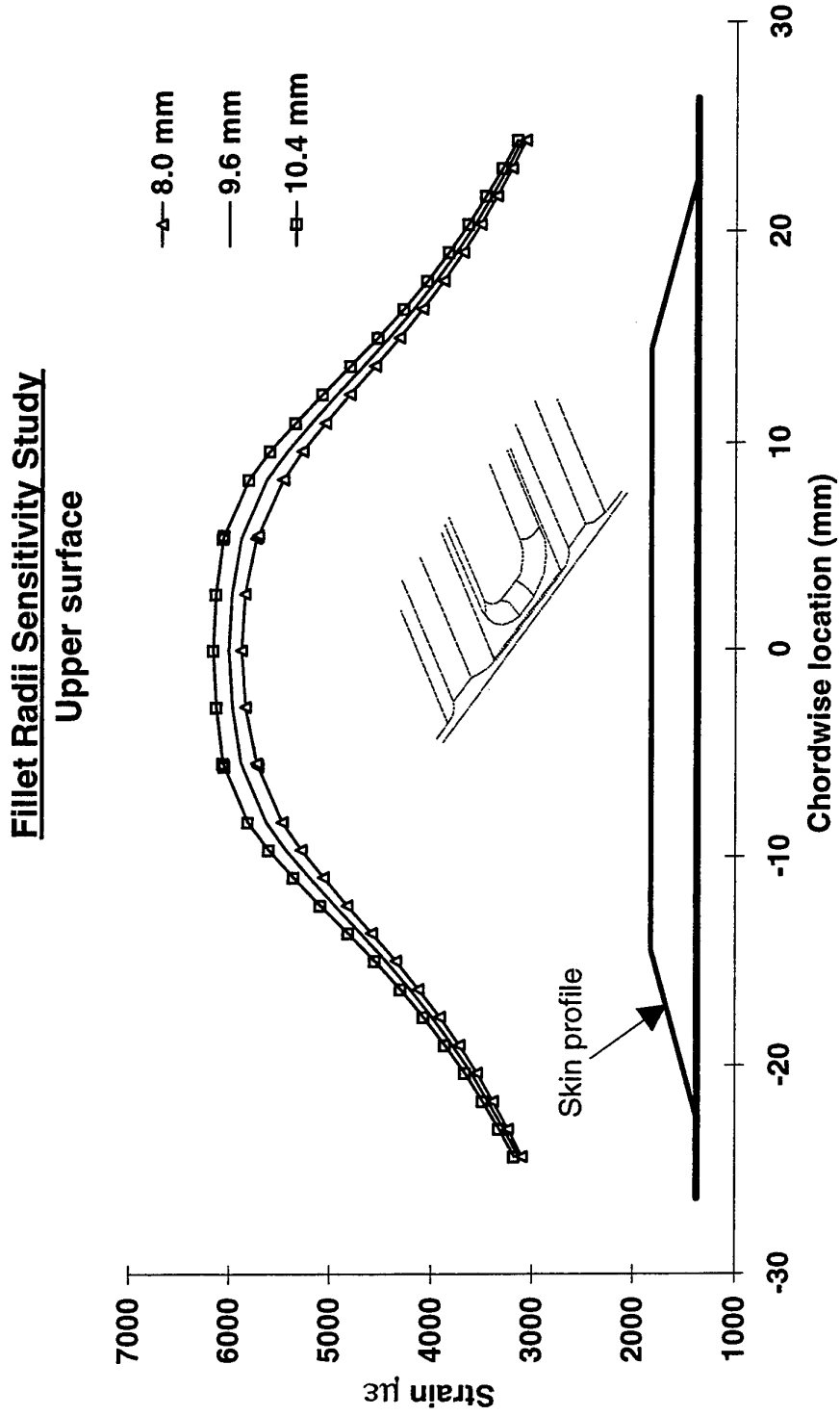

Appendix B 2

Comparison of deformed shapes with differing fillet radii at CPLT loading conditions

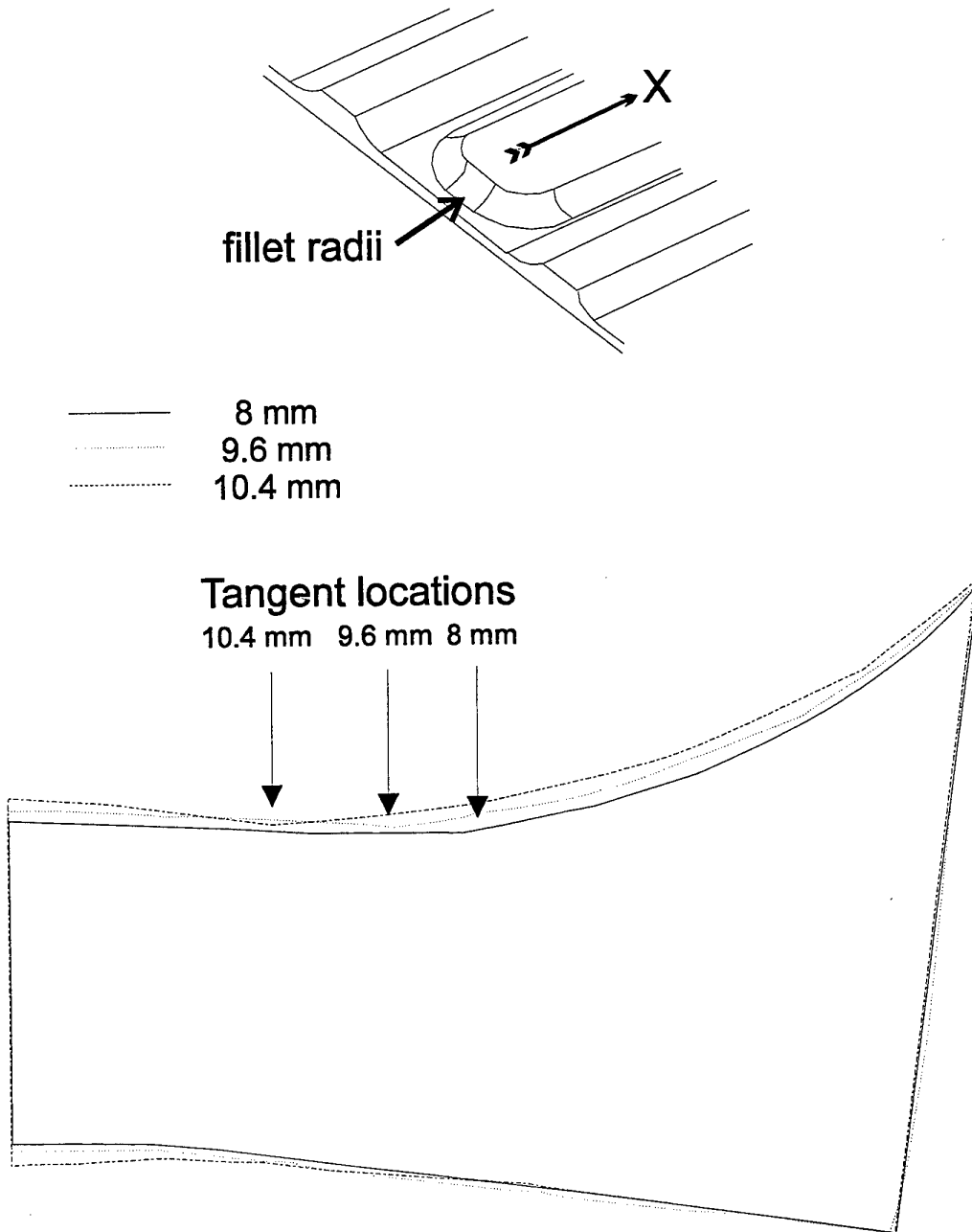

Appendix B 3

Uniaxial stress comparison at CPLT load conditions

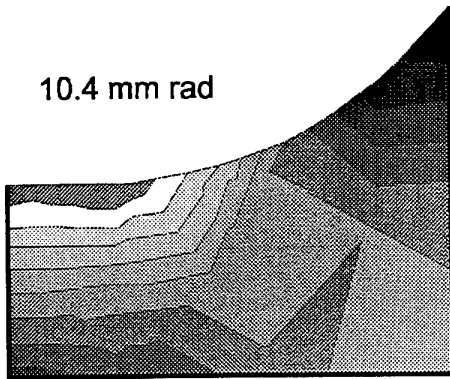
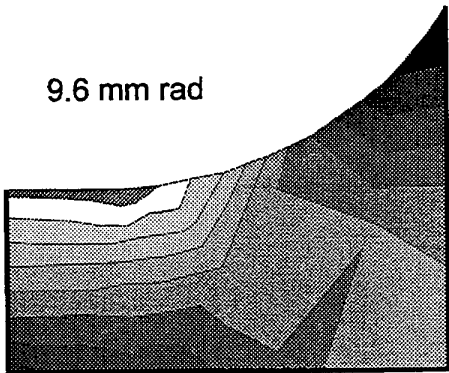
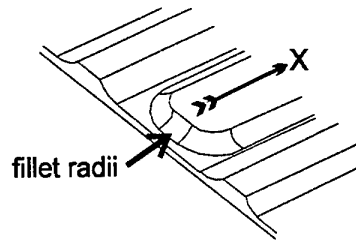
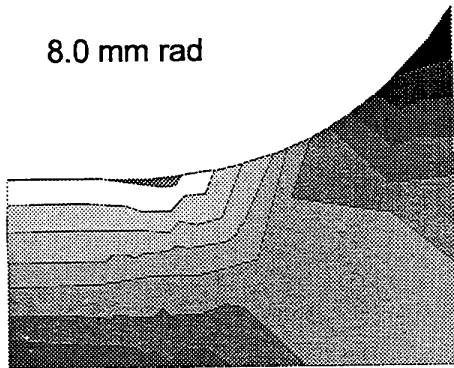

S_{xx} (MPa)

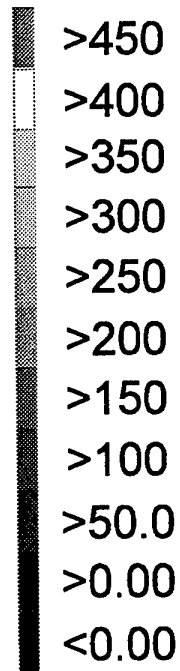

Appendix C 1

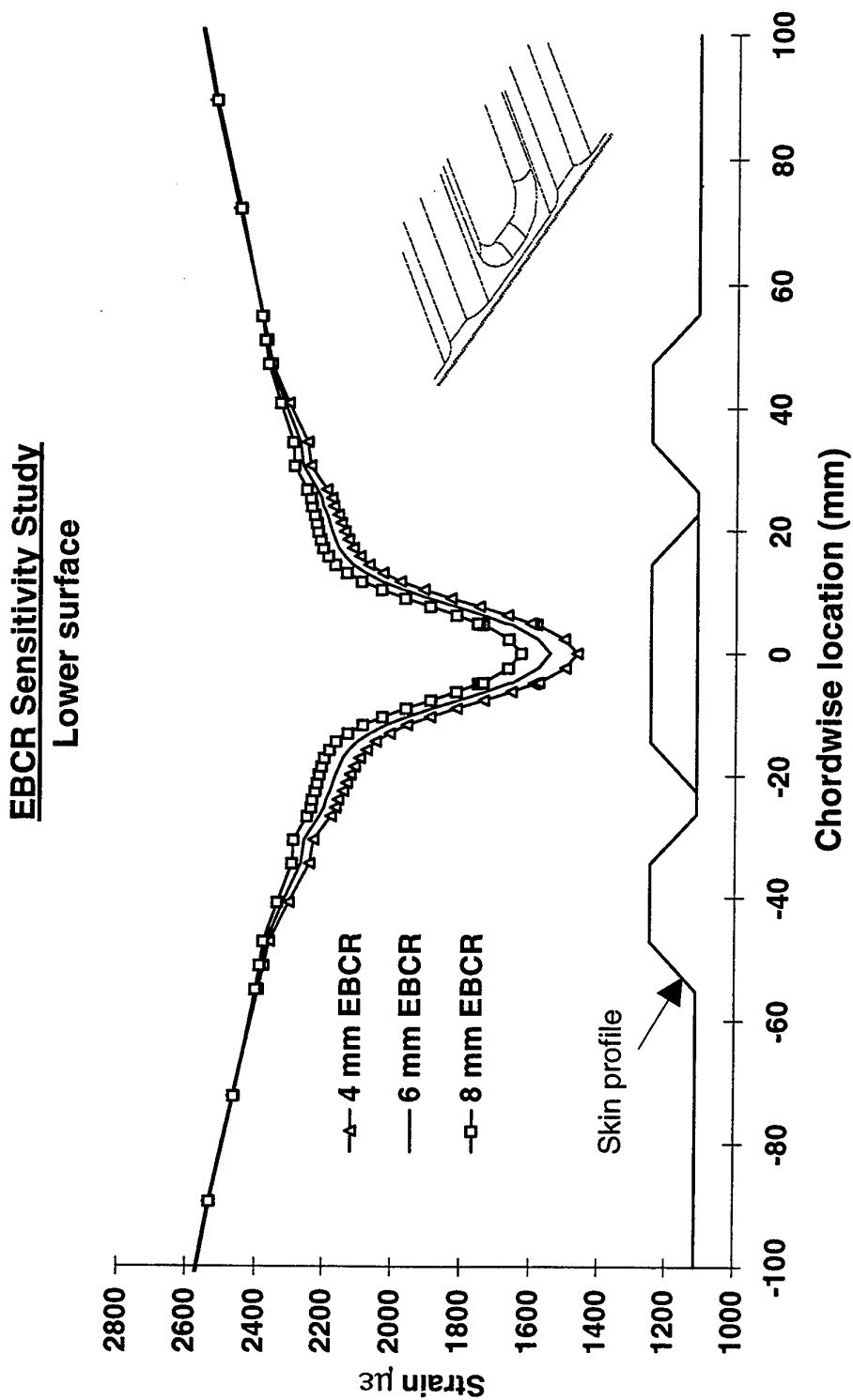

Appendix C 2

EBCR Sensitivity Study Upper surface

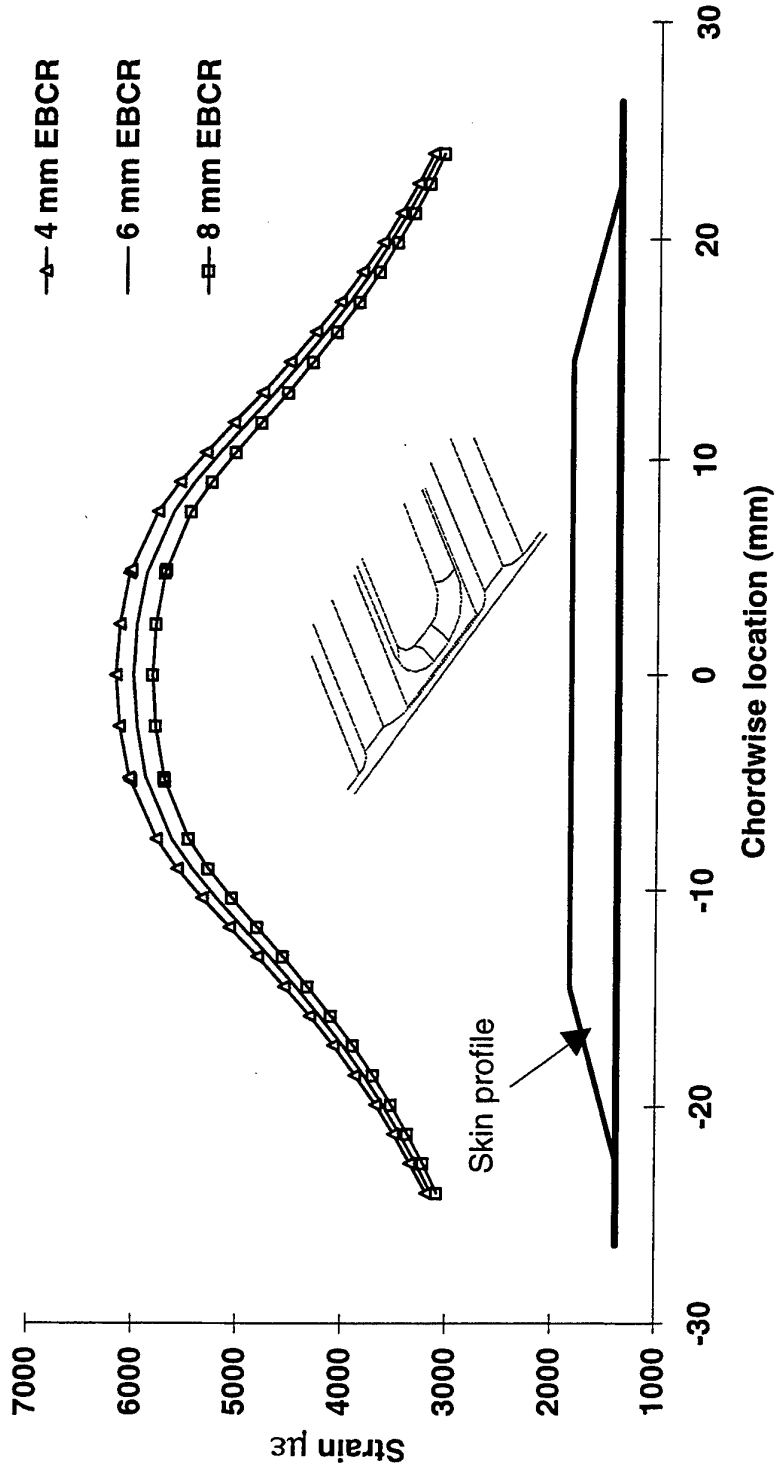

DISTRIBUTION LIST

Sensitivity Study of an AMRL Finite Element Model of the F-111 Lower Wing Skin
Structural Detail at Forward Auxiliary Spar Station (FASS) 281.28

D. Keeley, R. Callinan and S. Sanderson

AUSTRALIA

1. DEFENCE ORGANISATION

a. Task Sponsor DTA

b. S&T Program

| | |
|--|---------------|
| Chief Defence Scientist | } shared copy |
| FAS Science Policy | |
| AS Science Industry and External Relations | |
| AS Science Corporate Management | |

Counsellor Defence Science, London (Doc Data Sheet)
Counsellor Defence Science, Washington (Doc Data Sheet)
Scientific Adviser to MRDC Thailand (Doc Data Sheet)
Director General Scientific Advisers and Trials/Scientific Adviser Policy and
Command (shared copy)
Navy Scientific Adviser (3 copies Doc Data Sheet and 1 copy distribution list)
Scientific Adviser - Army (Doc Data Sheet and distribution list only)
Air Force Scientific Adviser
Director Trials

Aeronautical and Maritime Research Laboratory
Director

Electronics and Surveillance Research Laboratory
Director

Chief of Airframes and Engines Division
F. Rose
Task Manager
K. Walker
R. Callinan
S. Sanderson

DSTO Library

Library Fishermens Bend
Library Maribyrnong
Library DSTOS (2 copies)
Australian Archives
Library, MOD, Pyrmont (Doc Data sheet only)

c. Forces Executive

Director General Force Development (Sea) (Doc Data Sheet only)
Director General Force Development (Land) (Doc Data Sheet only)
Director General Force Development (Air)

e. Army

ABCA Office, G-1-34, Russell Offices, Canberra (4 copies)

f. Air Force

Wing Commander E. Wilson, OIC ASI, HQLC, RAAF Williams, Laverton VIC
Flight Lieutenant S. White, SRLMSQN, RAAF Amberley QLD
Mr M. Davis ATS1A, 501 Wing, RAAF Amberley QLD

g. S&I Program

Defence Intelligence Organisation
Library, Defence Signals Directorate (Doc Data Sheet only)

i. B&M Program (libraries)

OIC TRS, Defence Central Library
Officer in Charge, Document Exchange Centre (DEC), 1 copy
*US Defence Technical Information Centre, 2 copies
*UK Defence Research Information Center, 2 copies
*Canada Defence Scientific Information Service, 1 copy
*NZ Defence Information Centre, 1 copy
National Library of Australia, 1 copy

2. UNIVERSITIES AND COLLEGES

Australian Defence Force Academy
Library
Head of Aerospace and Mechanical Engineering
Senior Librarian, Hargrave Library, Monash University
Librarian, Flinders University

3. OTHER ORGANISATIONS

NASA (Canberra)
AGPS

OUTSIDE AUSTRALIA

4. ABSTRACTING AND INFORMATION ORGANISATIONS

INSPEC: Acquisitions Section Institution of Electrical Engineers
Library, Chemical Abstracts Reference Service
Engineering Societies Library, US
American Society for Metals
Documents Librarian, The Center for Research Libraries, US

5. INFORMATION EXCHANGE AGREEMENT PARTNERS

Acquisitions Unit, Science Reference and Information Service, UK
Library - Exchange Desk, National Institute of Standards and Technology, US
National Aerospace Laboratory, Japan
National Aerospace Laboratory, Netherlands

SPARES (10 copies)

Total number of copies: 61

| | | | | | | | |
|--|--------------------------|-----------------------------|---|---|--|------------------------------------|--|
| DEFENCE SCIENCE AND TECHNOLOGY ORGANISATION DOCUMENT CONTROL DATA | | | | 1. PRIVACY MARKING/CAVEAT (OF DOCUMENT) | | | |
| | | | | | | | |
| 2. TITLE Sensitivity Study of an AMRL Finite Element Model of the F-111 Lower Wing Skin Structural Detail at Forward Auxiliary Spar Station (FASS) 281.28 | | | 3. SECURITY CLASSIFICATION (FOR UNCLASSIFIED REPORTS THAT ARE LIMITED RELEASE USE (L) NEXT TO DOCUMENT CLASSIFICATION) Document (U) Title (U) Abstract (U) | | | | |
| 4. AUTHOR(S) D. Keeley, R. Callinan and S. Sanderson | | | 5. CORPORATE AUTHOR Aeronautical and Maritime Research Laboratory PO Box 4331 Melbourne Vic 3001 | | | | |
| 6a. DSTO NUMBER DSTO-TN-0060 | | 6b. AR NUMBER AR-009-909 | | 6c. TYPE OF REPORT Technical Note | | 7. DOCUMENT DATE September 1996 | |
| 8. FILE NUMBER M1/9/118/1 | 9. TASK NUMBER 94/118 | 10. TASK SPONSOR DTA | | 11. NO. OF PAGES 18 | | 12. NO. OF REFERENCES 7 | |
| 13. DOWNGRADING/DELIMITING INSTRUCTIONS None | | | 14. RELEASE AUTHORITY Chief, Airframes and Engines Division | | | | |
| 15. SECONDARY RELEASE STATEMENT OF THIS DOCUMENT <i>Approved for public release</i> OVERSEAS ENQUIRIES OUTSIDE STATED LIMITATIONS SHOULD BE REFERRED THROUGH DOCUMENT EXCHANGE CENTRE, DIS NETWORK OFFICE, DEPT OF DEFENCE, CAMPBELL PARK OFFICES, CANBERRA ACT 2600 | | | | | | | |
| 16. DELIBERATE ANNOUNCEMENT No limitations | | | | | | | |
| 17. CASUAL ANNOUNCEMENT Yes | | | | | | | |
| 18. DEFTEST DESCRIPTORS F-111 aircraft, finite element analysis, fatigue tests | | | | | | | |
| A baseline three-dimensional Finite Element (FE) model has been developed for a structural detail on an F-111 lower wing skin at Forward Auxiliary Spar Station (FASS) 281.28. This location has been the site of cracking in both RAAF and USAF aircraft. The FE model was developed using precise thickness measurements appropriate for a specific full-scale test wing available at AMRL (serial number A-10-824). This document is a sensitivity study of the finite element model. The effects of small dimensional changes falling within the range of the manufacturing tolerances are investigated. This will allow a quantitative assessment of the stress variations which could be expected at that location within the F-111 fleet. | | | | | | | |