

SPECIAL REPORT

97-1

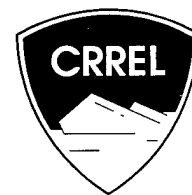

Frost Shielding Protection of a Water Line, Berlin, New Hampshire

Barry A. Coutermarsh

January 1997

UNCLASSIFIED
Approved for public release
Distribution Unlimited

DTIC QUALITY INSPECTED 

Abstract: The standard practice of burying water and sewer lines beneath the frost line in cold regions can be expensive when ledge or other difficult material is within the burial depth. If the pipeline can be buried at a shallower depth and still be protected from freezing, a significant savings in excavation costs can be realized. A finite element (FE) program was developed to predict frost penetration depth around buried utility pipelines. The program was

used to design and assess the feasibility of various insulation configurations around a water line buried within the frost-susceptible depth in Berlin, New Hampshire. Extensive temperature monitoring was performed to evaluate both the insulation design and the prediction accuracy of the FE program. The first-year results are very promising, showing good accuracy between the FE results and actual temperatures.

How to get copies of CRREL technical publications:

Department of Defense personnel and contractors may order reports through the Defense Technical Information Center:

DTIC-BR SUITE 0944
8725 JOHN J KINGMAN RD
FT BELVOIR VA 22060-6218
Telephone 1 800 225 3842
E-mail help@dtic.mil
msorders@dtic.mil
WWW http://www.dtic.dla.mil/

All others may order reports through the National Technical Information Service:

NTIS
5285 PORT ROYAL RD
SPRINGFIELD VA 22161
Telephone 1 703 487 4650
1 703 487 4639 (TDD for the hearing-impaired)
E-mail orders@ntis.fedworld.gov
WWW http://www.fedworld.gov/ntis/ntishome.html

A complete list of all CRREL technical publications is available from:

USACRREL (CECRL-TL)
72 LYME RD
HANOVER NH 03755-1290
Telephone 1 603 646 4338
E-mail techpubs@crrel.usace.army.mil

**For information on all aspects of the Cold Regions Research and Engineering Laboratory, visit our World Wide Web site:
<http://www.crrel.usace.army.mil>**

Special Report 97-1



**US Army Corps
of Engineers**

Cold Regions Research &
Engineering Laboratory

Frost Shielding Protection of a Water Line, Berlin, New Hampshire

Barry A. Coutermarsh

January 1997

19970313 083

Prepared for
OFFICE OF THE CHIEF OF ENGINEERS

Approved for public release; distribution is unlimited.

PREFACE

This report was prepared by Barry A. Coutermarsh, Research Civil Engineer, Applied Research Branch, Research and Engineering Directorate, U.S. Army Cold Regions Research and Engineering Laboratory (CRREL), Hanover, New Hampshire.

Funding for this work was provided under the Construction Productivity Advancement Research (CPAR) program. The report was technically reviewed by Dr. Gary E. Phetteplace of CRREL and Dr. John Budinscak of U.C. Industries, Inc.

The contents of this report are not to be used for advertising or promotional purposes. Citation of brand names does not constitute an official endorsement or approval of the use of such commercial products.

CONTENTS

| | Page |
|---|------|
| Preface | ii |
| Introduction | 1 |
| Background | 1 |
| Numerical model | 2 |
| Second Avenue | 4 |
| Labossiere Street | 6 |
| Initial design | 6 |
| Final design | 6 |
| Construction | 7 |
| General physical layout | 7 |
| Pipe construction | 7 |
| Instrumentation layout | 10 |
| Preliminary data | 11 |
| Air temperatures and frost penetration | 11 |
| Pipe temperatures | 12 |
| Shield temperatures | 12 |
| Numerical model assessment | 13 |
| Preliminary conclusions and recommendations | 15 |
| Literature cited | 15 |
| Abstract | 16 |

ILLUSTRATIONS

Figure

| | |
|--|----|
| 1. Example of a finite element mesh | 2 |
| 2. Average air temperatures from 1972 used to represent FE surface temperature | 3 |
| 3. Berlin, New Hampshire, filter plant water temperatures | 4 |
| 4. Physical layout of FE-modeled domain | 4 |
| 5. FE output showing isothermal progression | 5 |
| 6. Storm drain location, immersion thermocouple, and the start of the insulated pipe section on Labossiere Street | 8 |
| 7. Instrumentation layout along the pipeline | 8 |
| 8. Jigs made from 2- × 4-in. lumber to hold the insulation during installation | 9 |
| 9. Staggered insulation board joints | 9 |
| 10. Insulated service tap entering the shield | 9 |
| 11. Residential sewer line crossing through the shield | 10 |

| Figure | Page |
|---|------|
| 12. Sewer line crossing with thermocouple layout | 11 |
| 13. Thermocouple layout at the test site | 11 |
| 14. Air temperature vs. FE surface temperature | 12 |
| 15. Control string vertical temperature profiles | 12 |
| 16. Comparison of lower and middle immersion thermocouples and filter plant temperatures | 12 |
| 17. Immersion temperature vs. ground temperature | 13 |
| 18. Comparison of lower immersion thermocouple, underdrain, and earth temperatures | 13 |
| 19. Inside vs. outside shield temperatures | 13 |
| 20. Pipe vs. ground temperature | 13 |
| 21. FE surface temperature vs. actual surface temperatures, Laboissiere Street | 14 |
| 22. FE surface vs. actual temperatures | 14 |

TABLES

| Table | Page |
|--|------|
| 1. Numerical model material data | 5 |
| 2. Insulation data | 7 |

Frost Shielding Protection of a Water Line, Berlin, New Hampshire

BARRY A. COUTERMARSH

INTRODUCTION

In areas that experience freezing temperatures for any appreciable time, protecting water lines from freezing is a major consideration in the design and construction of water systems. The normal procedure is to bury the systems below the anticipated frost penetration depth. The presence of ledge above this depth can greatly increase the cost of burying the system. This is not only because of the expense of blasting and removing the rock but also because frost penetration is deeper in areas of ledge, requiring an even deeper pipe burial depth to protect against freezing.

Frost shielding is the practice of protecting the water line from freezing by adding extruded polystyrene insulation to retard the heat loss from the water within the line. It has the potential of reducing the burial depth of the system from what would normally be necessary. Balanced against the increased cost of the extruded insulation is the decreased depth required for safe burial of the pipe and thus savings in both the volume and cost of removed material.

The major impediments to routinely insulating lines are the lack of performance data and design guidance for the shield configuration and insulation thickness. A finite element (FE) computer program at CRREL can model two-dimensional frost penetration into the ground and describe both numerically and visually the temperature regime expected in and around any potential shield design. This FE program allows the designer to model several different insulation configurations and perform "what-if" types of calculations against expected temperature conditions.

This report illustrates its use in the design of an insulation shield for an 8-in. (20-cm)-diam. water line in Berlin, New Hampshire, in an area where ledge is present to the surface. It details the

construction of the shield, methods used during construction to handle the 2- × 8-ft (0.6- × 2.4-m) extruded polystyrene insulation boards that make up the shield, and the temperature sensor layout we used to monitor the shield's performance. The project will be used to assess the performance of both the FE program and the insulation shield under in-situ conditions.

Background

This frost-shielding project was developed under the Corps of Engineers, Civil Works, Construction Productivity Advancement Research (CPAR) program. Under the program, the City of Berlin, New Hampshire, Water Works and U.C. Industries, Inc., a manufacturer of extruded polystyrene insulation, are partners with CRREL in demonstrating the concept of insulating water lines to protect them from freezing. The project has essentially two components. The first is to develop a shield design using a CRREL-developed FE program. The second is to construct and assess the performance of an in-situ shield based upon the numerical design. More information about the finite element program is available in Coutermarsh and Phetteplace (1991a, 1991b).

The practice of frost-shielding utility lines has been used most notably in Norway, where Per Gunderson has been instrumental in its development. He has developed nomographs to estimate the shield configuration and thickness using certain environmental parameters. The Norwegians have also pioneered collocating sewer lines within the same shield as water lines. The warmer sewer lines supply heat to the shield, which helps to keep inside-shield temperatures above freezing (Gunderson 1975, 1989).

It was the success of Gunderson's work that encouraged us to further investigate the concept of frost shielding in this country. We felt, how-

ever, that the nomographs were of limited use in conditions where several different soil materials were present, the geometry of the pipeline was nonstandard, or the ambient temperature profiles were erratic. With the advent of more powerful personal computers, we felt that an FE program would offer the designer more flexibility in choosing shield design based upon the conditions present.

The city of Berlin, New Hampshire, situated in the White Mountain range of northern New Hampshire, has a population of about 12,000. The town's geography is mountainous with large areas of shallow ledge throughout. The Berlin water department approached CRREL to see if we could offer any advice on the freezing problems they were experiencing with their water distribution system.

The water in the distribution system is from two sources: the Ammonoosuc Filter Plant and the Androscoggin Treatment Plant. The Ammonoosuc plant gets its water off the bottom of a reservoir, and the Androscoggin plant is supplied from the Androscoggin River. The Ammonoosuc plant only filters and chlorinates the water, but the Androscoggin plant provides a full range of treatment. During the winter, the water leaving the Ammonoosuc plant tends to be roughly 2°C warmer than the water leaving the Androscoggin plant.

The distribution system itself is old, with many of the lines made up of small galvanized 2-in. to 6-in. (5.1 to 15.2-cm)-diam. pipes. A large portion of these pipes are buried in or on top of ledge, tend to be very shallow, and are prone to freezing. The frost penetration in this area of New Hampshire can be 1.5 m (5 ft) or more. The problem is so acute that from January through March the water users on lines prone to freezing are asked to run their water continuously. They are given an abatement on their water fees by being billed on the average of the previous three months' usage rather than on their actual usage during the freezing period. This causes a situation where, during the winter months, water is being run through the system just to prevent freezing. The cost of this water is in effect subsidized by all the users. The excess water is discarded into the sewer system, where it puts a greater load on the sewer treatment system and therefore increases treatment cost.

The city is in the process of upgrading its water system to correct this situation. The presence of shallow ledge, however, makes this an ex-

tremely costly procedure. Ledge excavation is relatively expensive because of the need to blast to break up the material for removal. The situation is exacerbated because frost penetrates much deeper in ledge than it does in granular soils. This results from two factors: first, the ledge has a higher thermal conductivity than soil, and second, because it has no moisture content, it has no latent heat (the energy used when changing the phase of a material, e.g., changing water to ice). It can be seen that an effective shielding method that would allow a shallower burial depth than would otherwise be necessary would have the potential to save a substantial amount of money and resources. U.C. Industries, Inc. expressed an interest in the concept of frost-shielding and became a partner with the water department to provide guidance and insulation for the project as well as to be the technology transfer point of contact to private industry.

This report describes the numerical design and construction of a 20.3-cm (8-in.) shielded water line in Berlin, New Hampshire. The ongoing project will evaluate its performance and adjust the design procedure accordingly as data are evaluated.

NUMERICAL MODEL

The physical dimensions of the pipeline and surrounding material are used to construct an FE mesh (Fig. 1). Only half of the physical configuration needs to be modeled, since the other half will be identical to the modeled half. A mesh is therefore constructed that represents one side of a ver-

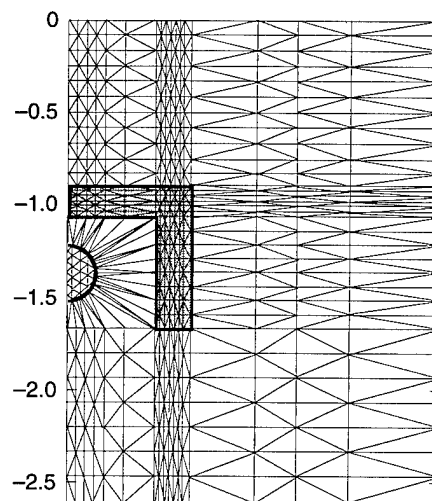

Figure 1. Example of a finite element mesh.

tical line of symmetry through the insulation and pipe. This mesh consists of a series of triangular elements arranged in zones that accurately represent the physical configuration of the material being studied. The density of the element spacing depends upon the temperature gradients expected in any zone. Areas of steep gradients (high temperature change) should have elements that are spaced closely together. Thus, in Figure 1 there are areas that have very closely spaced elements representing the insulation boards. These are the darker vertical and horizontal bands evident in the figure. The insulation boards are placed in an inverted U immediately around the pipe, which is the darker half-round object at the lefthand side of the mesh. The dark bands extend beyond the boundaries of the insulation boards because it is easier to generate them as a continuous band throughout the mesh and then just designate the board itself in the material file by their coordinates. For example, the top horizontal board extends from the lefthand side of the mesh to the righthand edge of the vertical band. The vertical board extends from the bottom of the horizontal band to just below the bottom of the pipe. Each of the other materials present in the physical configuration is designated by the appropriate coordinates of the zone of elements in the mesh. The program uses this information, along with the thermal conductivity, density, specific heat, latent heat, and phase-change temperature of the components to determine heat transfer throughout the region under study. More information on finite element (FE) modeling can be found in textbooks on the subject (Segerlind 1984).

Once the physical configuration is determined, all the boundary conditions that will affect the mesh temperatures have to be determined for a full year's cycle. In our case, the surface temperature, water temperature, and geothermal heat flux (heat generated within the core of the earth that slowly filters up to the surface) were the boundary conditions that were needed for our problem. Along the vertical line of symmetry, the boundary condition is adiabatic (zero heat flux).

The surface temperatures used in the model were determined from monthly extreme air temperature records for the Berlin area from 1926 to 1992. From the records, 1972 appeared to be the coldest year, and the average of the coldest and warmest temperatures within each

month were used as our surface temperatures in the model.

Actual surface temperature is usually different from air temperature and can be determined by the use of so-called "n-factors." These factors relate the effect that surface material has upon the surface temperature (Lunardini 1981). By multiplying the air temperature by the appropriate material n-factor, the surface temperature can be determined. A good illustration of the surface temperature difference is the hot temperatures found in summer on a black asphalt surface, which will normally be several degrees hotter than the air temperature.

Using air temperature as our mesh surface boundary temperature gives us, on average, a somewhat colder surface than the actual would be. This was desirable from a conservative point of view so our shield design would be somewhat oversized. Figure 2 is a graph of the air temperatures determined from our records. The time scale is in months and represents a full year starting in January.

Water temperature was more difficult to determine. We obtained monthly treatment and filter plant outflow water temperatures for 1992 and part of 1993 and used these records to estimate the water temperature in the pipe. There can be a significant error in these temperatures because the water temperature will change as it travels throughout the distribution system. How it changes is not known. For instance, in the winter, the water from the plants might cool significantly as it travels through pipes that are buried in ground that is below freezing. Conversely, since a large portion of Berlin's water is from a surface source, it may in fact be cooler than the ground for a large part of the season. The preliminary

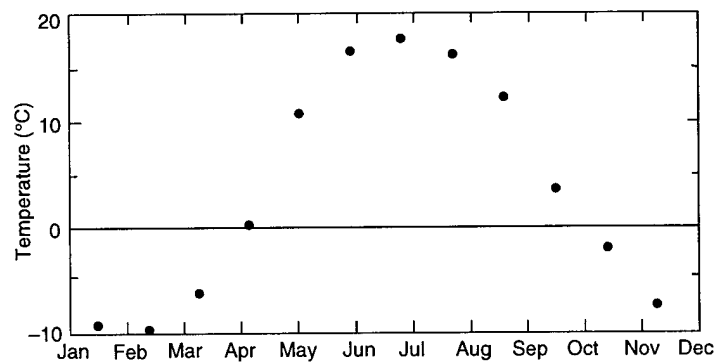

Figure 2. Average air temperatures from 1972 used to represent FE surface temperature.

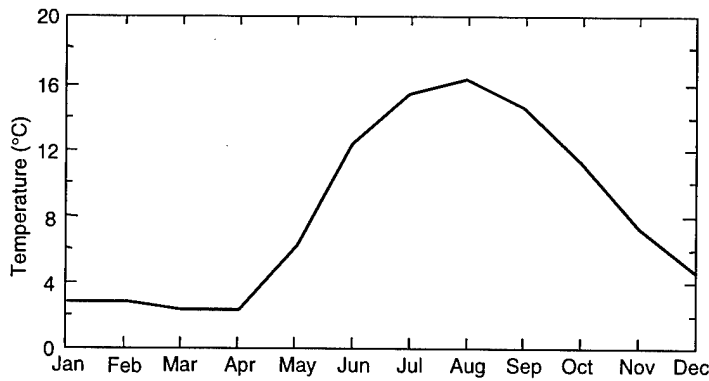

Figure 3. Berlin, New Hampshire, filter plant water temperatures.

data, which we will show later, indicates that early in this year the water at the filter plant was colder than the ground for portions of the year. Figure 3 shows the water temperatures we used in our simulation.

In our numerical simulations we model to a depth of 10 m (32.8 ft), which can reasonably be assumed to represent the depth of zero annual temperature amplitude (Phukan 1985). This is the depth at which the effect of the changing surface temperature is not noticeable. At this bottom boundary we apply an average value of the geothermal heat flux of 0.063 W/m^2 (Lunardini 1981) moving upward into the mesh.

SECOND AVENUE

Figure 4 is an example of the basic FE configuration used to model what we initially expected the soil and pipe configuration to look like at our

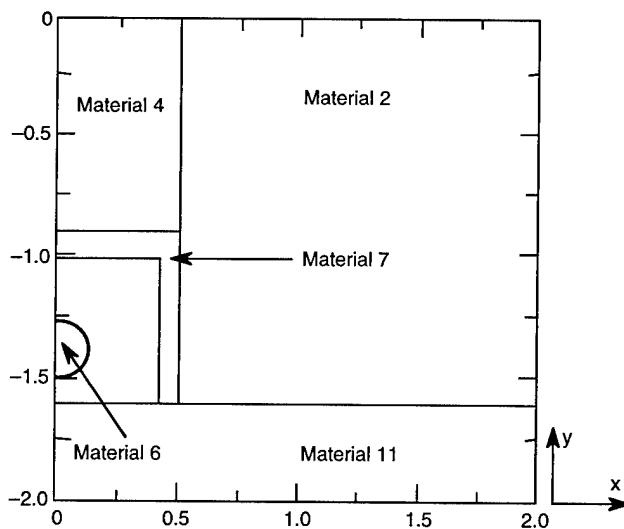

Figure 4. Physical layout of FE-modeled domain.

original test site on Second Avenue in Berlin. The pipe is 20.3-cm (8-in.) I.D. ductile iron set 1.5 m (5 ft) deep. Material 6 is the pipe and water, material 4 represents the backfill area around the pipe, material 7 is the extruded polystyrene insulation boards, and materials 2 and 11 are the surrounding earth and ledge material, respectively. The specific dimensions and materials associated with each zone might change, depending upon what the designer wishes to experiment with. For instance, in our modeling we varied the pipe depth, insulation board thickness, and the width of the top insulation board to see the effect these changes would have upon the temperature profiles.

We thought that the pipe on Second Avenue could be installed about 1.5 m (5 ft) deep, but ledge was possible anywhere from 1.4 m to 2 m (4.5 ft to 6.5 ft). In Figure 4, material 11 was ledge and material 2 was a "silty sand" commonly found in the area. The backfill material 4 is a sand. As mentioned above, we varied the extruded polystyrene insulation (material 7) dimensions during the modeling process to investigate the effectiveness of different shield thicknesses and placement. Table 1 lists the materials and their properties.

During the numerical simulations, we defined a failure as the 0°C isotherm touching the pipe. This is a conservative approach, since water will remain at 0°C for some time before it freezes due to its latent heat. For the initial runs we did not apply any water temperature boundary condition to the pipe. This would be similar to a pipe with no flowing water. Commonly, water flowing in the pipe brings heat into the insulation shield, so modeling without water flow is usually a more conservative procedure.

The output from a numerical simulation is presented in graphical form by either graphs or contour plots. By watching how the 0°C isotherm progresses with time, the effectiveness of the insulation shield can be determined. Figure 5 shows a time series progression of five isotherms around and into a shield. Notice how the isotherms wrap around the shield and start to intrude not only at the top but also at the lower right corner. This is due to the higher-conductivity ledge at the bottom of the shield. This contour type of output is extremely helpful

Table 1. Numerical model material data.

| Material and state | Conductivity (J/hr m °C) | Density (kg/m ³) | Specific heat (J/kg °C) | Latent heat (J/m ³) |
|-----------------------------|-----------------------------|---------------------------------|----------------------------|------------------------------------|
| Material 4 | | | | |
| Sand | | | | |
| Frozen | 5616 | 1836 | 784.8 | |
| Unfrozen | 6228 | 1836 | 940.32 | 45.3 × 10 ⁶ |
| Material 6 | | | | |
| Water | | | | |
| Frozen | 7984.8 | 917.0 | 2096.2 | |
| Unfrozen | 2170.8 | 998.2 | 4183.92 | 334 × 10 ⁶ |
| Material 7 | | | | |
| Extruded polystyrene | | | | |
| | 104.04 | 28.84 | 1214.23 | |
| Material 11 | | | | |
| Rock | | | | |
| | 9242 | 2700 | 879 | |

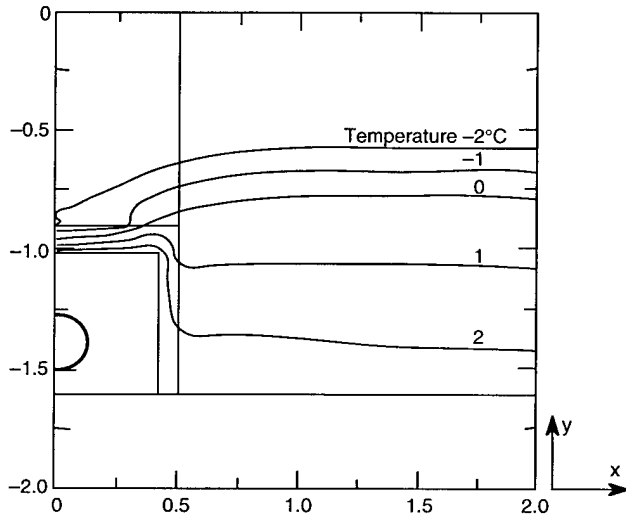

a. Mid-December.

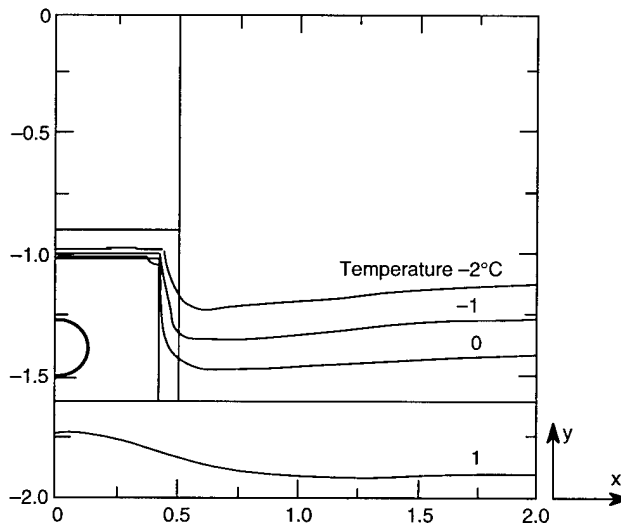

b. Mid-February.

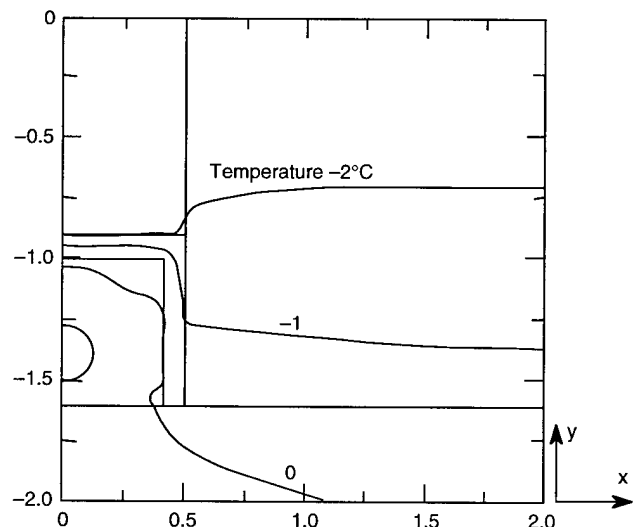

c. Early April.

Figure 5. FE output showing isothermal progression. The time steps are 12 h apart.

in assessing the shield design. A large amount of information can be displayed in a format that is easily interpreted.

Our previous modeling runs and the earlier work done by Gunderson suggest that a wide horizontal layer of insulation is effective at slowing frost penetration. We modeled this on the Second Avenue pipe configuration by using a 6-cm (2.4-in.)-thick layer of insulation in a total width of 2 m (6.5 ft). The numerical simulations predicted that this would prevent the 0°C isotherm from contacting the pipe. The problem, however, is that this width of insulation is usually impractical to excavate for in a normal utility line installation. That is why it is often preferable to use the inverted U configuration shown in Figure 5.

After modeling several different combinations of insulation thickness and shield width, using the inverted U, we found that a 10.2-cm (4-in.)-thick shield with a total minimum width of 101.6 cm (40 in.) would prevent the freezing front from touching the pipe.

We then modeled the pipe as being 1.37 m (4.5 ft) deep and found that there was not a practical insulation thickness that could prevent the freezing front from touching the pipe. The next approach we took was to see if water flowing in the pipe would supply enough heat to prevent freezing. We used a 15.2-cm (6-in.)-thick shield, 1.22-m (4-ft)-wide, and ran the model with a pipe boundary temperature to simulate water flowing in it. We then stopped the flow to see if the 0°C isotherm would progress to the pipe. In our model this is a two-step procedure.

The first step of the numerical simulation is performed with a specified pipe boundary temperature derived from the known water temperatures. This simulates the actual temperatures at any time we might need. These are then used as starting temperatures in the second step, for a numerical simulation without the specified pipe boundary temperatures. As noted earlier, this is equivalent to a situation where no water is flowing in the pipe. We then run the model for any length of time needed to determine if the 0°C isotherm progresses to the pipe.

The protection of the water pipe in the above situation is dependent upon the initial temperature of the water, the time of year the water stops flowing, and how long it remains off. In our simulations, we showed the time of maximum frost penetration to be approximately 85 days after 1

January, or 26 March, at about 2.5 m (8.2 ft) deep. If the water flow stopped at this time, our model showed it to be safe from freezing. We then stopped the water at the end of February and ran the model for 70 days or into the first of May. In this scenario the pipe got very cold but did remain (barely) above freezing.

From the above numerical simulations, we felt that a 1.2-m (4-ft)-wide shield with either 10.1- or 15.2-cm (4- or 6-in.)-thick insulation, depending upon how deep the pipe was buried, would be adequate.

LABOSSIERE STREET

Initial design

When the initial excavation began on Second Avenue it was discovered that the existing pipe leading into the avenue was tightly surrounded by ledge. It would have been very difficult and expensive to excavate around it while still maintaining water service to the dwellings on the line. We decided to move to our second-choice street—Labossiere. The water line in this street was a dead-end line about 123 m (405 ft) long, and records showed that the existing pipe was buried from 1.2 to 1.4 m (4 to 4.5 ft) deep. We dug three test pits along the length of the pipe, and these pits indicated that the closest ledge was about 1.37 to 1.52 m (4.5 to 5 ft) below the surface. Since this was essentially the same situation we had thought we had at Second Avenue, we felt that the design could remain the same.

Final design

It was quickly discovered during the initial excavation for the new pipeline that ledge was in fact present up to the surface for nearly the entire length of the pipeline. In an incredible stroke of bad luck, the only three places that showed ledge down to 1.4 to 1.5 m (4.5 to 5 ft) were the three spots where we had dug our test pits. Consequently, we found ourselves in a situation where the pipeline was being installed and our design was suspect. Again, this is because ledge has a much higher thermal conductivity and contains less moisture than soil. These two conditions allow the freezing front to advance faster and deeper through ledge than through relatively moist soil.

A series of numerical simulations were made that modeled ledge to the surface with a pipeline buried 1.5 m (5 ft) deep. This depth was close to

where the pipeline initially started out at the beginning of the street. During the blasting and excavation we tried to maintain at least this depth to give us an extra buffer against the cold surface temperatures.

The numerical model predicted that the pipe would get very close to 0°C but would not go below it by using our final design from Second Avenue: a 1.5-cm (6-in.)-thick extruded polystyrene insulation with a total shield width of 1.2 m (4 ft) with the pipe resting at the 1.5-m (5-ft)-deep level.

Several points should be made about our designs based upon the numerical simulations:

1. The temperatures used at the model surface are air temperatures from a very cold year. The temperatures used at the model surface should be ground-surface temperatures, which tend to be warmer overall than the air temperatures because of the effect of solar energy. This study will help to quantify this effect.

2. The ledge is modeled as if it were solid unbroken rock. Natural ledge is frequently broken and can have areas of water flow and other anomalies. We expect the effective thermal conductivity of the natural ledge to be less than our modeled ledge.

3. Our failure criteria could be much too conservative. We "turn off" the water flow and assume that the pipe fails if afterwards the 0°C isotherm touches it. In reality there is probably some water flowing frequently within the pipe, which would bring a little heat into the shield area.

4. A great uncertainty exists in the water temperature boundary that we applied to the pipe. As mentioned above, we used the water temperatures at the treatment and filter plants for our pipe boundary temperatures. This may or may not be correct, depending upon how the water temperature changes as it travels through the distribution system.

5. Another concern in this study is the effect that Berlin's very cold water temperatures will have within an insulated system. Will the cold temperatures quickly remove the stored heat within the insulation shield, much faster than would have occurred had the heat loss only been caused by heat conduction to the surrounding ground? One of the ways an insulated system is effective is by preventing the rapid loss of this stored energy to the surrounding ground. The cold pipe temperatures could cancel out this benefit.

CONSTRUCTION

General physical layout

Labossiere Street is a dead-end hillside street on the northwest side of Berlin. Our test section started at the intersection of Sixth Avenue and continued up the roughly 17% slope of Labossiere to its end at the base of a mountain of bare rock that projects upwards from the end of the street.

The water line serving the users on the street is a dead-end line that runs about 128 m (420 ft) up the west side of the street.

Pipe construction

The shield design called for a 15.2-cm (6-in.)-thick layer of insulation in an inverted U around the pipe. The sides of the U were 61 cm (2 ft) high, with the bottom of the legs even with or slightly below the bottom of the pipe. The total width of the shield was 1.2 m (4 ft). The shield was constructed of 5.1-cm (2-in.)-thick, 4 × 8-ft SSE boards of Foamular® 250 extruded polystyrene. This material meets the specification requirements of ASTM C578, Type IV. The boards have lines scored at 40.6, 61, and 81.3 cm (16-in., 24-in. and 32-in.) spacing across their width, which make them easy to break at the job site and leaves a clean even line where they break. Consequently, the 61-cm (2-ft)-high sides of the shield could easily be obtained from the 4 × 8-ft. (1.2 × 2.4-m) boards. Table 2 lists insulation data.

The new 8-in. ductile iron pipe construction started with a T connection into the existing water line at Sixth Avenue and proceeded up Labossiere Street. We did not start insulating the line from this T because of the presence of a storm drain line that ran down Sixth Avenue and crossed over the new water line just up from this connection, as shown in Figure 6. We were concerned that cold air would be flowing through the underdrain and would cool down the water pipe where they cross, so we installed a thermocouple to monitor the temperature at the bottom of the drain pipe. The stations shown in Figure 7 start where the storm drain crosses the water line. The

Table 2. Insulation data.

| | <i>Thermal conductivity (J/hr m °C)</i> | <i>Density (kg/m³)</i> | <i>Specific heat (J/kg °C)</i> |
|---------------|---|---------------------------------------|------------------------------------|
| Foamular® 250 | 93.46 | 28.84 | 1339.8 |

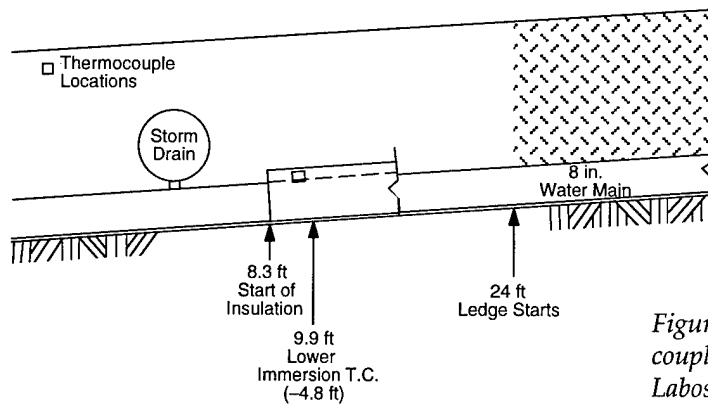

Figure 6. Storm drain location, immersion thermocouple, and the start of the insulated pipe section on Labossiere Street.

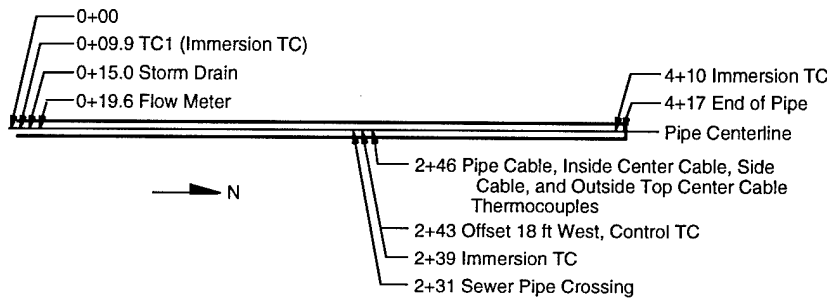

Figure 7. Instrumentation layout along the pipeline.

insulation shield begins about 2.4 m (8 ft) past the underdrain.

The top of the new water line at the storm drain is about 1.5 m (5 ft) below the surface. A backhoe was used initially to excavate for the new line, as the ledge that was encountered was relatively soft. We quickly ran into very competent ledge, however, and the ditch line had to be blasted; a larger excavator was brought in to remove the debris. We tried to clear the rock down to 1.8 m (6 ft) deep with a minimum 1.2-m (4-ft)-wide ditch. The width varied depending upon the amount of rock that was loosened in the blasting.

After the loose rock was removed, a layer of sand about 15.2 cm (6 in.) deep was added to cushion the pipe on the ledge at the bottom of the ditch. We positioned some insulation jigs made from 2- x 4-in.-diam. lumber into this sand and along the centerline of the pipe layout to hold the bottom of the side pieces of insulation. These jigs prevented the sides from springing out at the bottom during the backfilling operation. At the top we used similar jigs to firmly hold the top of the sides from moving in or out during the backfilling. These top jigs also maintained a 1.2-m (4-ft) width at the top of the sides. Figure 8 shows both the bottom and top jigs.

A section of pipe was laid on top of these jigs and centered in the ditch, after which the sides of the shield were installed. It is important to provide even mating surfaces and to stagger the insulation joints to prevent a direct path for heat loss out of the shield. Three layers of the 5.1-cm (2-in.)-thick extruded polystyrene insulation were necessary to get our final design thickness, so the boards were staggered as shown in Figure 9. Any slope changes were made gradually to avoid a gross vertical misalignment of the side boards. The top jigs were added after the sides were installed, and together with the bottom jigs they held the boards firmly in place during the backfilling. The sand backfill was alternated between the inside and outside of the shield sides to prevent the walls from caving in under the soil pressure. It was brought up even with the top of the side boards, the top jigs were removed, and a vibratory compactor was used to compact the sand. At this point the sand inside the shield was evened off, usually by dragging the back of one of the jigs across the tops of the side insulation. This made a smooth, level surface for the top insulation to rest on. The top insulation was staggered in the same manner as the sides and laid down over the prepared surface above the shield sides. Care should be taken to line up the edges with the sides and to

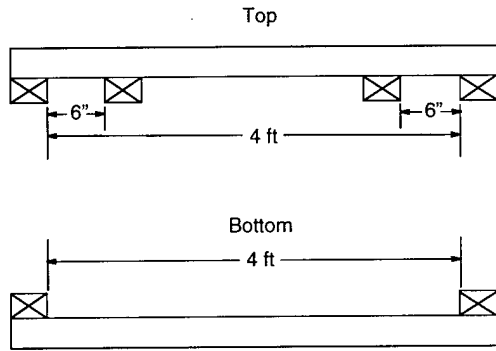

Figure 8. Jigs made from 2- × 4-in. lumber to hold the insulation during installation.

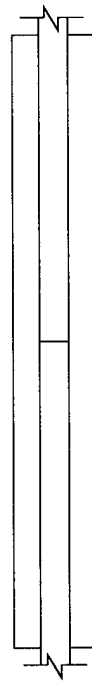

Figure 9. Staggered insulation board joints.

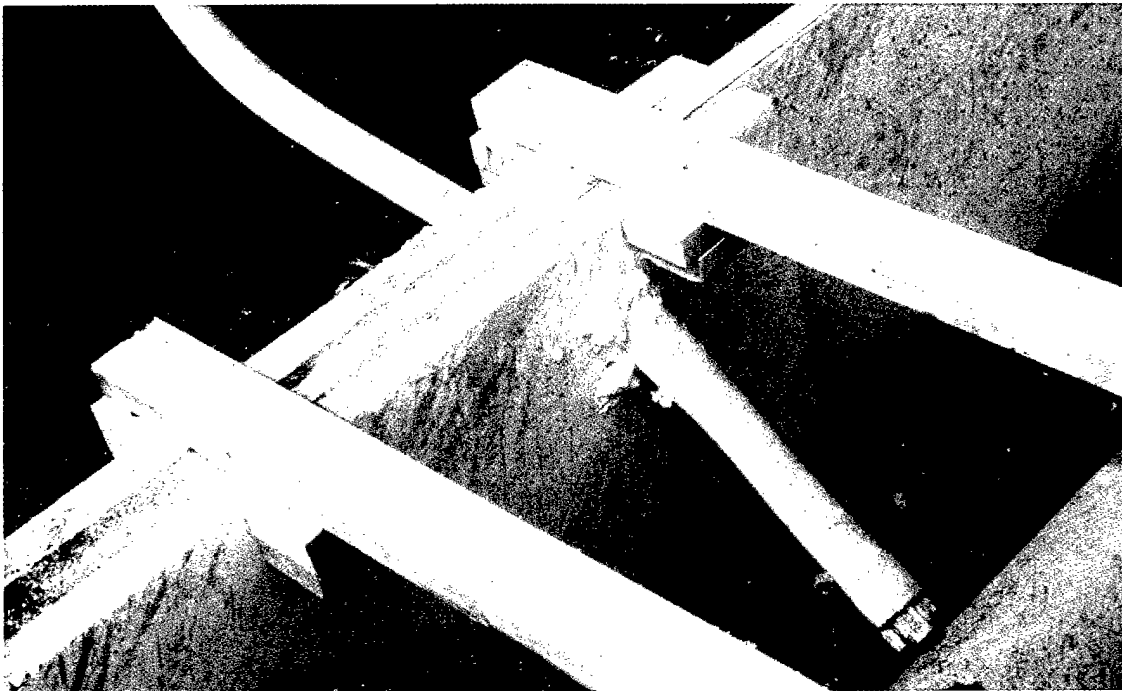

Figure 10. Insulated service tap entering the shield.

avoid any gaps that would provide a path for heat loss.

Figure 10 shows a service tap entering the shield. These taps were insulated with closed-cell pipe insulation, and the hole made in the insulation shield was foamed with a closed-cell spray insulation. Figure 11 shows a residential sewer

line crossing through the insulation shield at approximately 70 m (231 ft) up the pipeline. The sides of the shield were notched so the insulation would fit over the pipe, and then insulation was fitted into these notches under the water pipe after the sides were installed. Some spray foam was added to close up any remaining gap be-

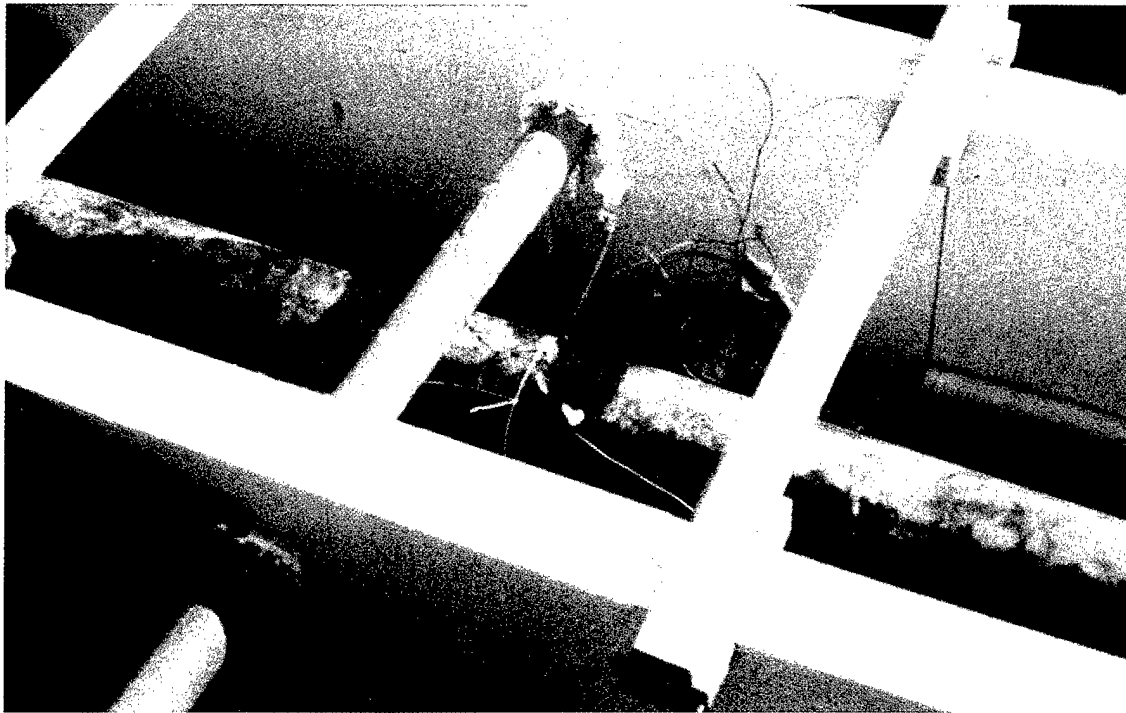

Figure 11. Residential sewer line crossing through the shield.

tween the sewer pipe and the insulation, as shown in Figure 11.

The shield was constructed in the manner described above up to the end of the line at approximately 127 m (417 ft). It would have been desirable to run the insulation shield 1.5 to 3 m (5 to 10 ft) past the end of the pipe, but ledge prevented this. The installation of the shield was not the limiting factor in the speed of the pipe laying; the ledge blasting and removal took considerably longer than the time needed to install the insulation. Backfilling was slowed slightly by the extra care taken around the insulation sides, but this time was minimized after we gained confidence in the ability of the jigs to keep the insulation from moving during the process.

INSTRUMENTATION LAYOUT

The general experimental plan called for monitoring temperatures at several points along the pipe with thermocouples, detailed below, as well as an extensive thermocouple layout at a test section about 73 m (240 ft) up the pipeline. In this application we used copper/constantan, type T thermocouples. The temperature data is automatically recorded by a Fluke 2286 datalogger that

was installed in the basement of a house on Labossiere Street. This house is about 110 m (360 ft) up the street and about 37 m (120 ft) from our main test section. We also installed water flow meters in the pipe at two locations but were disappointed to discover that both failed to function properly. Figure 7 is a profile view of the as-built pipeline with several points of interest marked. Three immersion thermocouples were installed into the pipe at 3.1, 73, and 125 m (10, 240, and 410 ft) from the beginning of the insulation. These allow us to monitor the water temperature as it progresses up the street. At our main test site we have also installed thermocouples around the outside of the pipe near the middle immersion thermocouple. This will allow us to tell if there is any significant difference between the temperatures of the water and the outside of the pipe.

The bottom immersion thermocouple gives us the temperature of the water near the entrance of the test pipe. This will be a baseline temperature of the water as it enters the test section, before any influence of the shield. A flow meter was installed at 6.1 m (20 ft) up the pipe but, as mentioned before, it is not working properly. We had hoped to know the water flow into the test section by this meter. Another thermocouple was placed on the outside of the pipe at about 24.4 m

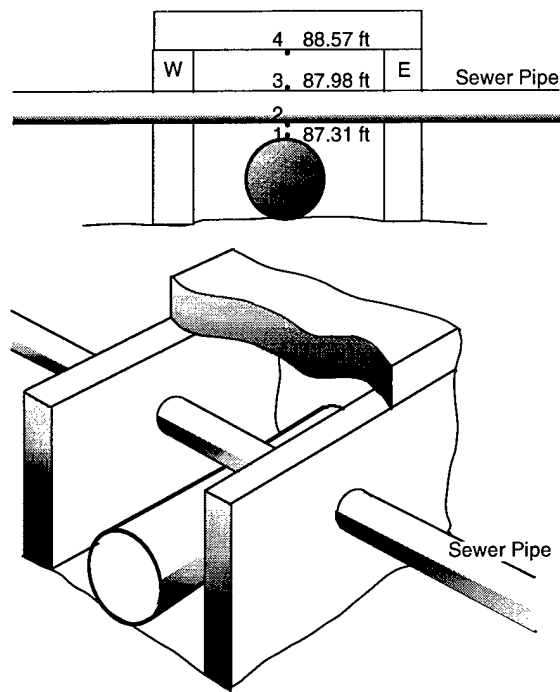

Figure 12. Sewer line crossing with thermocouple layout.

file in Figure 13. We also installed an immersion thermocouple and a flow meter at this location. As before, this flow meter does not appear to be working. The thermocouple layout at the main test section will enable us to characterize the thermal environment around the shield. The control string will give us temperatures that we would expect to find in an undisturbed area. The temperatures obtained at the surface of the test section will be used as our surface boundary temperatures in the numerical model, and the temperatures from the immersion thermocouple will be used as our pipe boundary temperatures.

Three more thermocouples were installed at the site. One is on the normally dry portion of a hydrant standpipe just above the main test section at about 104 m (340 ft). There is an immersion thermocouple at the end of the pipeline at 125 m (410 ft) and an outside air temperature thermocouple off the outside north wall at 73 Labossiere Street. We planned to compare air and surface temperatures using this thermocouple and the previously mentioned surface thermocouples at the main test section.

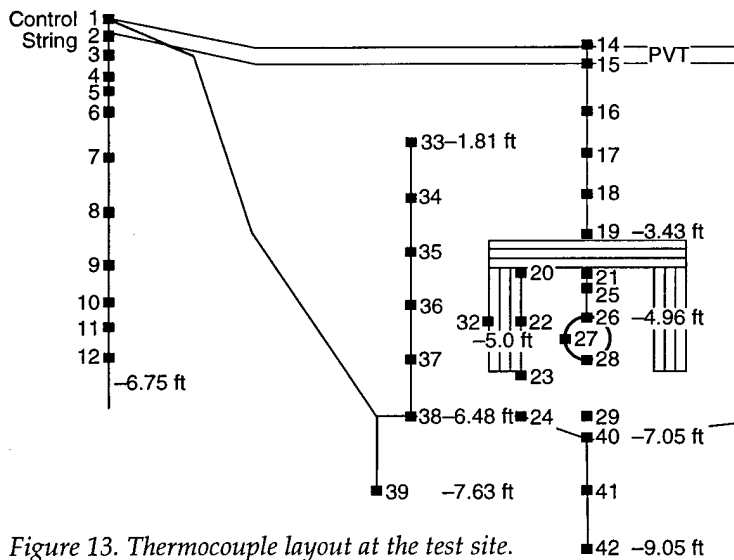

Figure 13. Thermocouple layout at the test site.

(80 ft). The sewer line crossing at 70.4 m (231 ft) gave us an opportunity to measure the effect, if any, that the relatively warmer sewer line would have on the temperatures within the shield. Figure 12 shows the sewer line and the placement of the four thermocouples at this location.

The main instrumentation section was at approximately 73 m (240 ft) along the pipe. Here we installed 40 thermocouples, as shown in the pro-

PRELIMINARY DATA

Air temperatures and frost penetration

The winter of 1994-95 was unusually warm and was therefore not an optimum test for the shielding concept. Some of the temperatures collected from the beginning of data collection on 9 September 1994 until 17 March 1995 are shown in Figure 14. Here the outside air temperature is compared with the numerical surface boundary temperature used in the design model. As mentioned previously, this FE boundary temperature was determined from air temperature records in the Berlin area. It can be seen that the numerical temperatures were generally colder than the air temperatures. Probably just as important is that when we did experience cold temperatures, they did not last very long. Notice that the temperatures above 0°C tend to last longer than those below 0°C, and there is never a prolonged cold spell. Under this type of temperature profile the ground never has a chance to maintain any appreciable frost penetration. In our situation in ledge, the

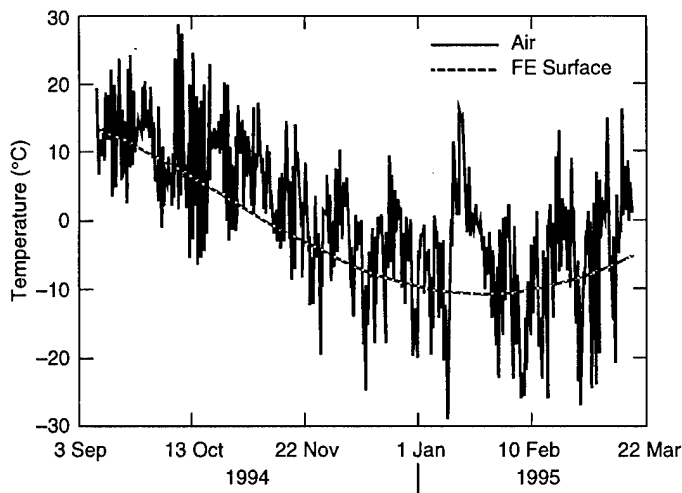

Figure 14. Air temperature vs. FE surface temperature.

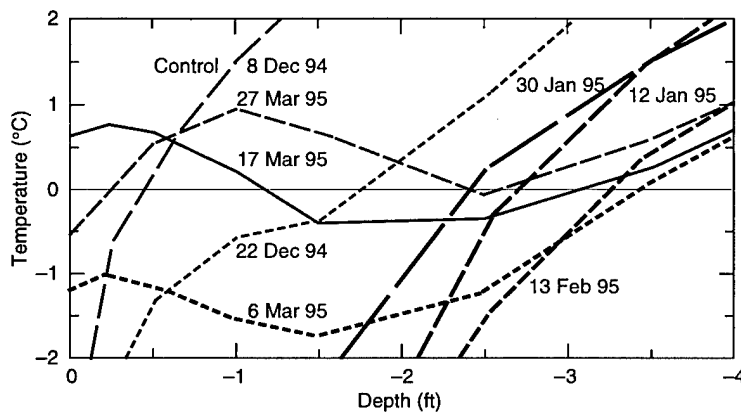

Figure 15. Control string vertical temperature profiles.

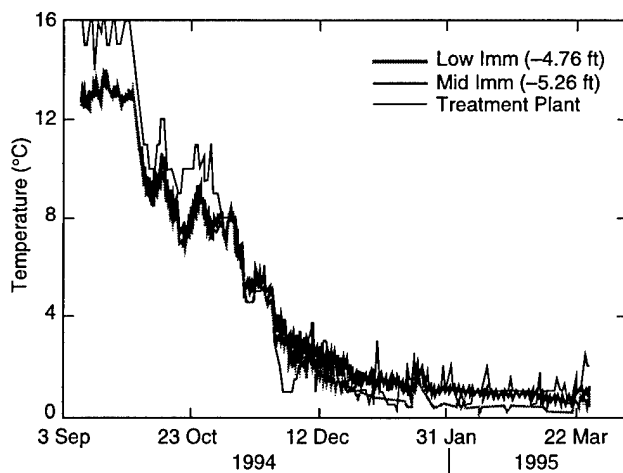

Figure 16. Comparison of lower and middle immersion thermocouples and filter plant temperatures.

frost penetration reacts quickly to surface temperature conditions. Figure 15 shows how rapidly the 0°C isotherm changed depth in the ledge, depending upon the surface temperatures. The maximum frost penetration that we recorded on Labossiere Street was about 1.1 m (3.5 ft).

Pipe temperatures

Berlin has very cold water in its distribution system, which makes it a challenge to design effective insulation. Figure 16 is a graph of water temperatures at the treatment plant and at the immersion thermocouples in the pipe at Labossiere Street. It is evident from this figure that in September the water at the plant is warmer than at the beginning of Labossiere Street (the lower immersion thermocouple) and has therefore lost heat to the ground as it flowed to Labossiere. As the winter season progresses, there are periods where the treatment plant water has warmed up as it has traveled to Labossiere.

The lower and middle immersion thermocouples are roughly the same depth below the surface, and the upper thermocouple is 1.2 to 1.5 m (4 to 5 ft) deeper. We can compare the lower and middle thermocouples (Fig. 17) and see that the middle thermocouple is about 0.5°C warmer than the lower, showing the temperature rise of the water as it travels up the street. The upper thermocouple shows the warmest temperatures, but this would be expected because of its greater depth. This makes it difficult to use the upper thermocouple to draw any conclusions about any beneficial effect from the insulation.

We were concerned that cold air flowing through the storm drain that passes over the water pipe at the beginning of Labossiere would hasten freezing in the immediate area. As can be seen from Figure 18, the temperatures recorded at the bottom of the storm drain were in fact warmer than the lower immersion thermocouple nearby. We do not know if this would hold in a year with colder air temperatures.

Shield temperatures

In comparing temperatures inside and outside the shield at the 1.5-m (5-ft) depth (Fig.

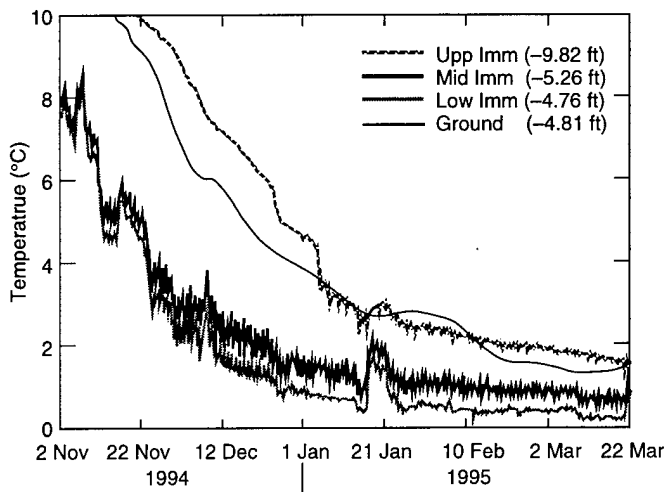

Figure 17. Immersion temperature vs. ground temperature.

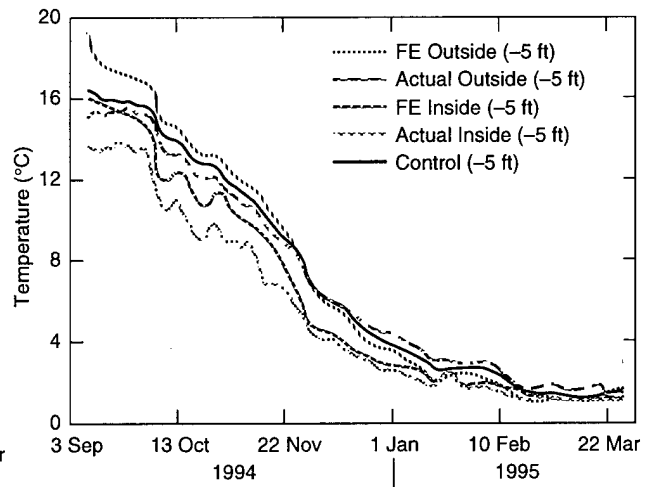

Figure 19. Inside vs. outside shield temperatures.

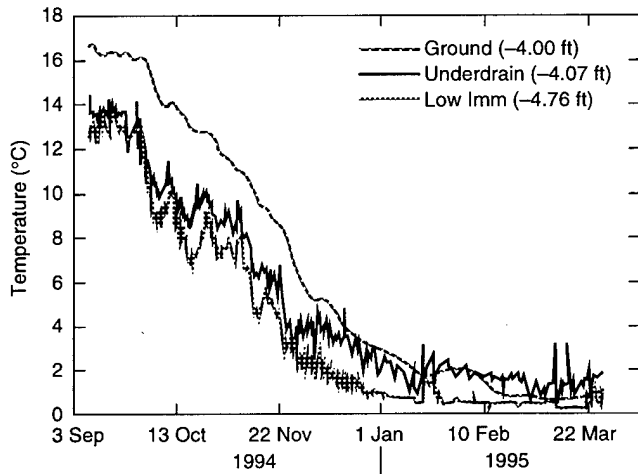

Figure 18. Comparison of lower immersion thermocouple, underdrain, and earth temperatures.

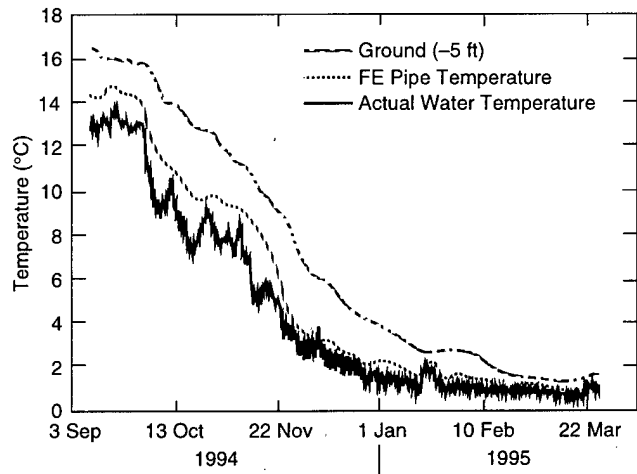

Figure 20. Pipe vs. ground temperature.

19), it is evident that the inside temperature is colder than the adjacent outside temperature. This is a result of the cold water temperatures in the shield and the fact that it was a warm year. In a normal year we would expect the inside shield temperature eventually to become warmer than the outside when the colder temperatures penetrate deeper into the ground as the year progresses. Figure 19 also shows the control temperatures, which are in ledge, becoming colder than the equivalent depth at the pipe, which is in sand backfill. It is evident in Figure 20 that the ground temperature at the depth of the shield did not get colder than the water temperatures.

NUMERICAL MODEL ASSESSMENT

The first shield was designed using air temperatures that we hoped would be representative of an extremely cold year. This was a conservative approach both from the climatological standpoint as well as the numerical modeling standpoint because the numerical model uses surface temperature, which is usually warmer than air temperature. Figure 21 shows the actual surface temperature from our control string on Labossiere and two regression lines. One regression represents the FE boundary temperature used in our

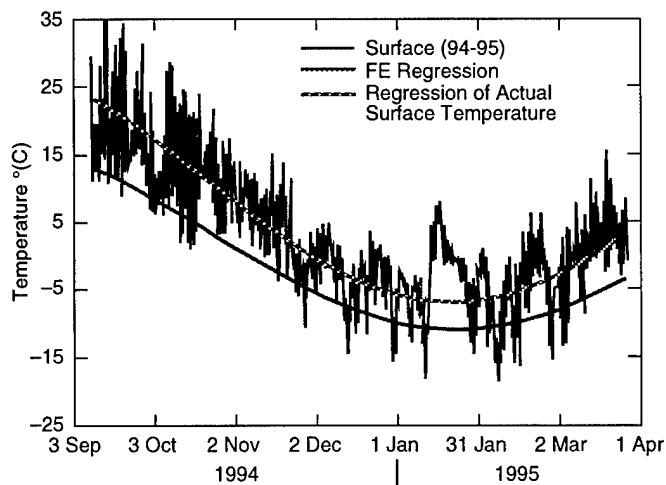

Figure 21. FE surface temperature vs. actual surface temperatures, Laboissiere Street.

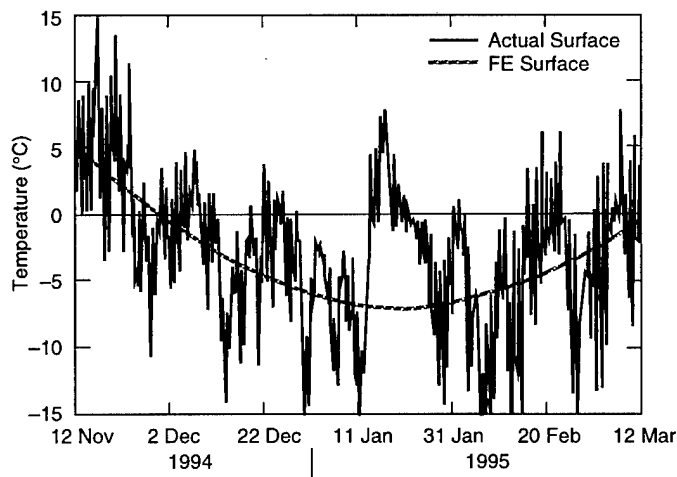

Figure 22. FE surface vs. actual temperatures.

shield design, and the other is one that fits the actual surface temperature. When the two regressions are compared it shows that the actual surface temperature was, on average, over 5.5°C warmer than the numerical surface temperature.

To better determine how the numerical model performed, the top and pipe boundary conditions were changed to reflect the actual temperatures more closely. To do this, we need a year's surface and pipe temperatures covering the model year of interest. We had been gathering data on Second Avenue for over a year, and these surface temperatures were compared with the available Laboissiere temperatures and adjusted to represent the Laboissiere temperatures from March 1994 to March 1995. The treatment plant water tem-

peratures from the same time period were used as our pipe temperatures.

Figures 19 and 20 also show the results from our numerical model. In Figure 19, the numerical model overpredicts the inside shield temperatures from September until about the first of December, but it does very well until the end of data in March. The overprediction is in part because our numerical pipe temperatures (from the treatment plant) are warmer than the actual pipe temperatures during September to December. The outside-the-shield numerical temperatures are at first warmer than the actual, until about mid-November. From this point until the end of December they represent the actual temperatures well. From then until the end of data in March our numerical model is somewhat colder than the actual temperatures.

The numerical model did poorly on predicting the overall frost penetration as compared with the control string temperatures in ledge. The maximum frost penetration predicted by our numerical model was roughly 1.8 m (5.9 ft) in about the mid to end of February. The actual maximum frost penetration was about 1.1 m (3.5 ft) during the first part of March.

The colder numerical temperatures and deeper modeled frost penetration could be due to our ledge thermal conductivity and/or the nature of the regression model and how it represents the actual temperatures.

Figure 22 shows a portion of the control surface temperatures from the beginning of November until the beginning of March.

Notice that once the regressed surface temperature line goes below 0°C it remains there until spring. In a normally cold year the actual temperatures are usually modeled well by this type of regression. However, in the winter of 1994-95, the actual temperatures rose above this regressed line and above freezing for a significant amount of time, as shown in the figure.

To check the effect that the regression line has upon frost penetration, we used actual surface temperatures rather than the regressed temperatures as the top boundary condition. The 0°C isotherm reacted much more realistically in this scenario, with the ground temperatures rising above 0°C during some of the warmer surface temperature times. The maximum frost penetration time was still around the mid to end of

February and decreased to 1.7 m (5.6 ft), a small improvement.

As mentioned earlier, we model ledge as a continuous mass of solid rock where actual ledge might not be so. During the construction of the pipeline it was evident that portions of the ledge were fractured, with seams of water within some of the fractures. These areas would greatly influence the thermal conductivity of the area and would slow frost penetration compared to solid rock. The above analysis suggests that we have a higher numerical ledge thermal conductivity than is appropriate.

PRELIMINARY CONCLUSIONS AND RECOMMENDATIONS

The winter of 1994–95 was too warm to provide us with a good test of the shielding concept. We still do not know what the water temperatures will be at the test site during a very cold year or what effect they will have upon the shield's performance.

It appeared that the shield was providing some protection to the water line, as the temperature of the water increased as it flowed up the hill. It is difficult to draw any firm conclusions, however, since the ground at the pipe depth remained above freezing throughout the winter.

Another area of concern is the performance of the service lines to the residences. These small-diameter lines are relatively shallow and uninsulated and would seem to be susceptible to freezing.

The numerical model appears to be functioning well where we have accurate input to check it

against. In our future comparisons we will be using the actual surface temperature as our top boundary condition to see if we can more closely model the maximum frost penetration depth. The results of these runs will help tell us if the ledge thermal conductivity needs to be adjusted and what effect inaccuracies in the material thermal conductivities have upon our model results.

LITERATURE CITED

- Coutermarsh, B.A. and G.E. Phetteplace** (1991a) Analysis of frost shields using the finite element method. In *Proceedings of the Seventh International Conference, Numerical Methods in Thermal Problems* (R.W. Lewis, J.H. Chin and G.M. Homsy, Ed.), Vol. VII, Part 1, p. 122.
- Coutermarsh, B.A. and G.E. Phetteplace** (1991b) Numerical analysis of frost shields. *Cold Regions 6th International Specialty Conference* (D.S. Sodhi, Ed.), American Society of Civil Engineers, p. 178.
- Gunderson, P.** (1975) Frostproofing of pipes. U.S. Army Cold Regions Research and Engineering Laboratory, Draft Translation 497.
- Gunderson, P.** (1989) Distribution network for district heat, electricity, water and sewage. Norwegian Building Research Institute, Oslo, Project Report 46 (in Norwegian).
- Lunardini, V.J.** (1981) *Heat Transfer in Cold Climates*. New York: Van Nostrand Reinhold Company.
- Phukan, A.** (1985) *Frozen Ground Engineering*. Englewood Cliffs, New Jersey: Prentice Hall, Inc.
- Seegerlind, L.** (1984) *Applied Finite Element Analysis*. 2nd edition. New York: John Wiley and Sons.

REPORT DOCUMENTATION PAGE

Form Approved
OMB No. 0704-0188

Public reporting burden for this collection of information is estimated to average 1 hour per response, including the time for reviewing instructions, searching existing data sources, gathering and maintaining the data needed, and completing and reviewing the collection of information. Send comments regarding this burden estimate or any other aspect of this collection of information, including suggestion for reducing this burden, to Washington Headquarters Services, Directorate for Information Operations and Reports, 1215 Jefferson Davis Highway, Suite 1204, Arlington, VA 22202-4302, and to the Office of Management and Budget, Paperwork Reduction Project (0704-0188), Washington, DC 20503.

| | | | | | |
|---|--|---|---|---|---------------------------|
| 1. AGENCY USE ONLY (Leave blank) | | 2. REPORT DATE January 1997 | | 3. REPORT TYPE AND DATES COVERED | |
| 4. TITLE AND SUBTITLE Frost Shielding Protection of a Water Line, Berlin, New Hampshire | | | | 5. FUNDING NUMBERS | |
| 6. AUTHORS Barry A. Coutermarsh | | | | | |
| 7. PERFORMING ORGANIZATION NAME(S) AND ADDRESS(ES) U.S. Army Cold Regions Research and Engineering Laboratory 72 Lyme Road Hanover, New Hampshire 03755-1290 | | | | 8. PERFORMING ORGANIZATION REPORT NUMBER Special Report 97-1 | |
| 9. SPONSORING/MONITORING AGENCY NAME(S) AND ADDRESS(ES) Office of the Chief of Engineers Washington, D.C. 20314-1000 | | | | 10. SPONSORING/MONITORING AGENCY REPORT NUMBER | |
| 11. SUPPLEMENTARY NOTES For conversion of SI units to non-SI units of measurement, consult ASTM Standard E380-93, <i>Standard Practice for Use of the International System of Units</i> , published by the American Society for Testing and Materials, 1916 Race St., Philadelphia, Pa. 19103. | | | | | |
| 12a. DISTRIBUTION/AVAILABILITY STATEMENT Approved for public release; distribution is unlimited. Available from NTIS, Springfield, Virginia 22161 | | | | 12b. DISTRIBUTION CODE | |
| 13. ABSTRACT (<i>Maximum 200 words</i>) The standard practice of burying water and sewer lines beneath the frost line in cold regions can be expensive when ledge or other difficult material is within the burial depth. If the pipeline can be buried at a shallower depth and still be protected from freezing, a significant savings in excavation costs can be realized. A finite element (FE) program was developed to predict frost penetration depth around buried utility pipelines. The program was used to design and assess the feasibility of various insulation configurations around a water line buried within the frost-susceptible depth in Berlin, New Hampshire. Extensive temperature monitoring was performed to evaluate both the insulation design and the prediction accuracy of the FE program. The first-year results are very promising, showing good accuracy between the FE results and actual temperatures. | | | | | |
| 14. SUBJECT TERMS Frost penetration Frost protection of pipes Frost shielding | | | Insulating buried pipes Pipe freezing Sewer line freezing | | 15. NUMBER OF PAGES 25 |
| | | | Utility line freezing Water line freezing | | 16. PRICE CODE |
| 17. SECURITY CLASSIFICATION OF REPORT UNCLASSIFIED | 18. SECURITY CLASSIFICATION OF THIS PAGE UNCLASSIFIED | 19. SECURITY CLASSIFICATION OF ABSTRACT UNCLASSIFIED | 20. LIMITATION OF ABSTRACT UL | | |