

# REPORT DOCUMENTATION PAGE

AFOSR-TR-08

0124 97

8

Public reporting burden for this collection of information is estimated to average 1 hour per response, gathering and maintaining the data needed, and completing and reviewing the collection of information; collection of information, including suggestions for reducing this burden, to Washington Headquarters Davis Highway, Suite 1204, Arlington, VA 22202-4302, and to the Office of Management and Budget, Pa.

Data sources, types of this 715 Jefferson

1. AGENCY USE ONLY (Leave blank)		2. REPORT DATE	3. REPORT TYPE AND DATES COVERED FINAL REPORT 01 Sep 95 - 31 Aug 96	
4. TITLE AND SUBTITLE (DURIP-95) Soliton-Locking for Stable Parametric Sources			5. FUNDING NUMBERS 61103D 3484/US	
6. AUTHOR(S) Dr Stegeman			8. PERFORMING ORGANIZATION REPORT NUMBER	
7. PERFORMING ORGANIZATION NAME(S) AND ADDRESS(ES) Optics and Lasers Univ of Central Florida Orlando, FL 32816-0150			10. SPONSORING/MONITORING AGENCY REPORT NUMBER F49620-95-1-0489	
9. SPONSORING/MONITORING AGENCY NAME(S) AND ADDRESS(ES) AFOSR/NE 110 Duncan Avenue Suite B115 Bolling AFB DC 20332-8050			11. SUPPLEMENTARY NOTES	
12a. DISTRIBUTION/AVAILABILITY STATEMENT APPROVED FOR PUBLIC RELEASE: DISTRIBUTION UNLIMITED			12b. DISTRIBUTION CODE	
13. ABSTRACT (Maximum 200 words)  In summary, due to a complicated sequence of events we were unable to perform the research that we expected in the last nine months. The equipment acquired specifically for the study of soliton-locking is just now operational. Because of these problems, a second system based on a 30 psec laser was built to investigate independently soliton-locking in an OPG/OPA system. It has been operated successfully in the soliton-locking regime. However, damage to the laser amplifier rod was found and has now been fixed.				
14. SUBJECT TERMS			15. NUMBER OF PAGES	
17. SECURITY CLASSIFICATION OF REPORT UNCLASSIFIED			16. PRICE CODE	
18. SECURITY CLASSIFICATION OF THIS PAGE UNCLASSIFIED		19. SECURITY CLASSIFICATION OF ABSTRACT UNCLASSIFIED		20. LIMITATION OF ABSTRACT

19970314 041

**Soliton-Locking for Stable Parametric Sources****Final Technical Report: Soliton-Locking for Stable Parametric Sources****Date: February 12, 1997****1. Abstract from Original Proposal:**

The proposed instrumentation was an Optical Parametric Amplifier (OPA) to be used to study a novel method for phase and amplitude stabilization of optical parametric sources, namely soliton-locking. The complete system was to consist of:

- (a) an argon ion pump laser
- (b) a modular Ti:sapphire laser
- (c) components for an Optical Parametric Generator

Our initial goal was to build our own optical parametric amplifier to investigate the impact of spatial soliton formation via "cascading" in second order nonlinear crystals. This process should stabilize the output phase front, produce a spatially clean output beam and stabilize the operation of the parametric device itself.

The total quoted cost of the laser/OPG/OPA system was \$135,000 which included \$90,000 requested from DURIP/AFOSR, and \$45,000 in matching funds and equipment. The full amount requested was funded by DURIP/AFOSR.

**2. System Purchased:**

The laser system purchased from Spectra Physics consisted of a Regeneratively Mode-locked Ti:sapphire laser, a Spitfire Regenerative Amplifier pumped by a Merlin Nd:YLF laser and an OPG/OPA capable of producing 30  $\mu$ J, 100 fsec pulses in the infrared (up to 2.4  $\mu$ ) at a 1 KHz rate. The total cost was \$190,000. The balance of the required funding was assembled from a variety of sources, including other grants, Cobb Family Chair funds and additional matching funds. This system greatly expands the capability of the originally proposed system, without compromising the original goals of studying soliton locking in a parametric device. The Spectra Physics OPA is modular in design and the goal was to modify the design to demonstrate soliton-locking. However, because there is a Regenerative Amplifier in the system, the pulse energy is over an order of magnitude higher than that of the originally proposed system. This allows not only the soliton-locking process to be investigated, but the final OPG/OPA can also be used as a source of high

Soliton-Locking for Stable Parametric Sources

energy, high spatial quality pulses for other experiments. Specifically, the added capability will allow:

- 1) Bandwidth limitations of cascading and solitary-wave locking to be investigated;
- 2) Nonlinearity of conjugated polymers to be investigated in the communications bands;
- 3) Ultrashort pulse spatial solitons for dynamic interconnects to be investigated.

1.3 Research Performed:

The new laser system was delivered in April 1996 and installed in May. The location is in the new CREOL building which was occupied by CREOL in February of 1996. There have continuing problems in the cooling water supply for the lasers in this building, including the laser system partially purchased with DURIP funds. This problem was finally fixed in December, 1996 by installing a separate heat exchanger for the Stegeman labs. A period of debugging time on the system followed which *appears* to have led to a reliable laser system. Thus progress towards soliton-locking with this system was impossible.

In order to pursue the problem of soliton-locking in parametric devices independently of the new laser, a second OPG/OPA system based on a 10 Hz Yd:YAG laser system producing 30 psec pulses was built. It was based on a pair of LBO crystals. (Since this laser operated at 10 Hz, it could be operated on the "city" water system and did not suffer from the cooling problems which plagued all of the high repetition rate lasers.) In this OPG/OPA, soliton locking was studied and observed.

The OPG/OPA experimental configuration is shown in Fig. 1.

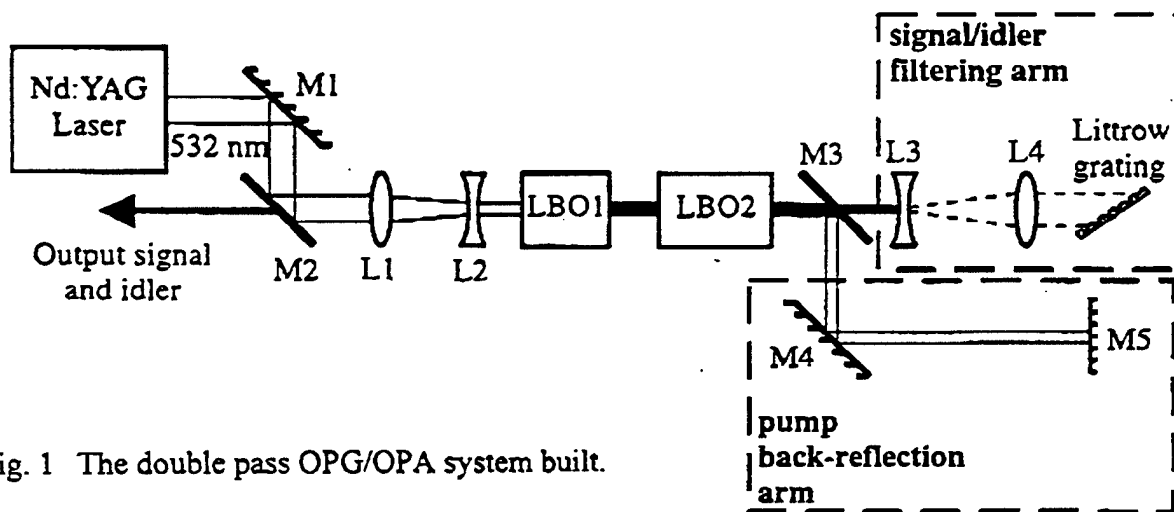

Fig. 1 The double pass OPG/OPA system built.

**Soliton-Locking for Stable Parametric Sources**

The beam profile after the first pass is shown in Fig. 2 as a sequence of beam profiles with increasing pulse energies. The narrowing of the output profile is evident with increasing pulse energy. The other important feature is the very spatially clean pulse profiles obtained, unusual for the first stage of an OPG. All of these properties are characteristic of the soliton-locking process.

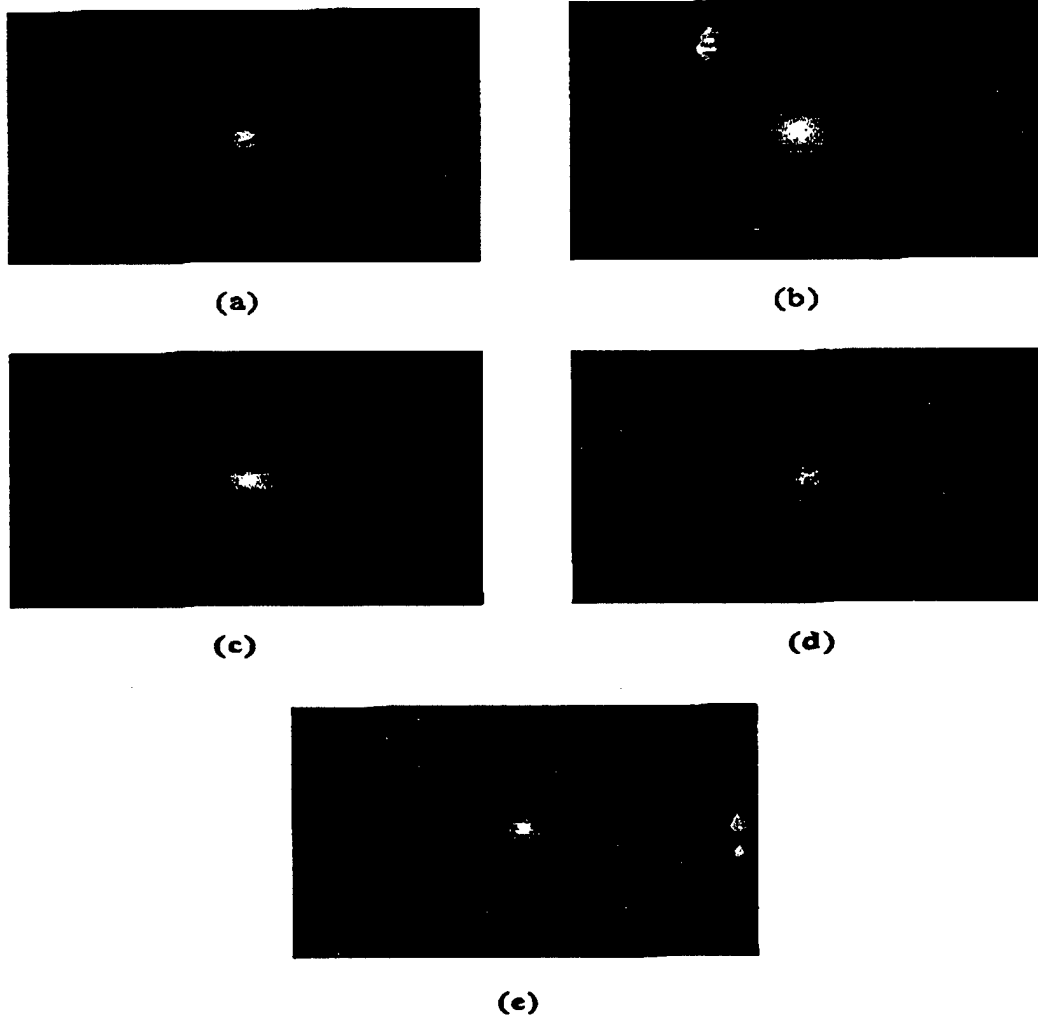
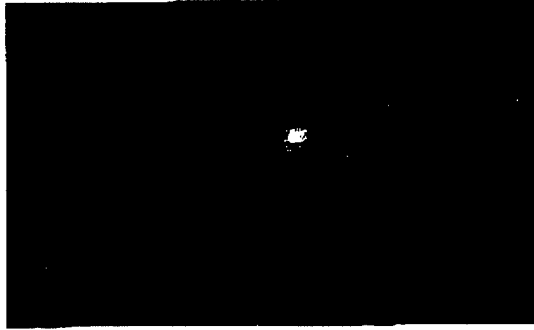

Fig. 2 Output pulse profiles from the OPG after a single pass through a single crystal. (a) input beam; (b), (c), (d), and (e) correspond to 4, 7.5, 15 and 17.5 mJ pump energies respectively.

**Soliton-Locking for Stable Parametric Sources**

The observed pulse profiles after the final pass through the amplifier are shown in Fig 3.



**Pump energy = 5 mJ**

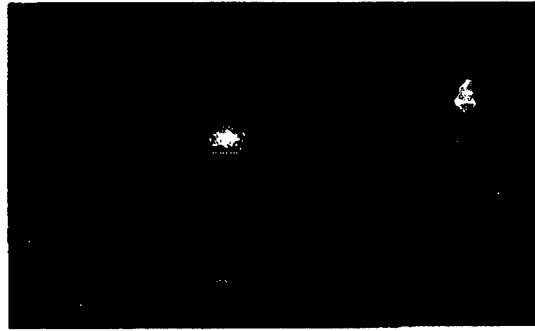

**Pump energy = 7.5**

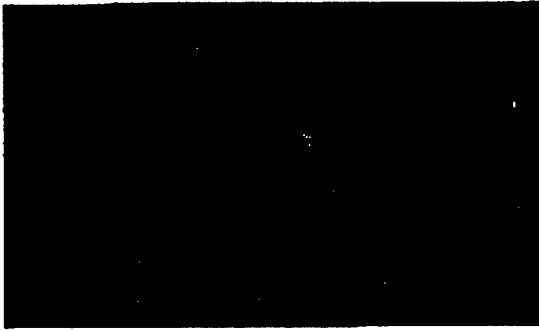

**Pump energy = 10 mJ**

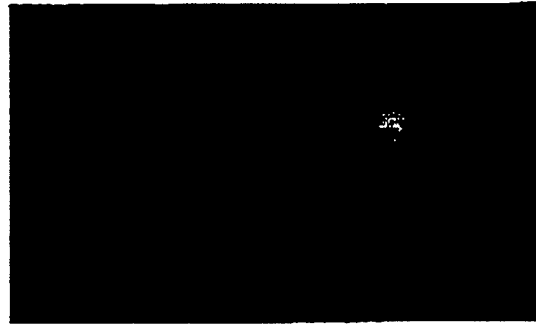

**Pump energy = 14 mJ**

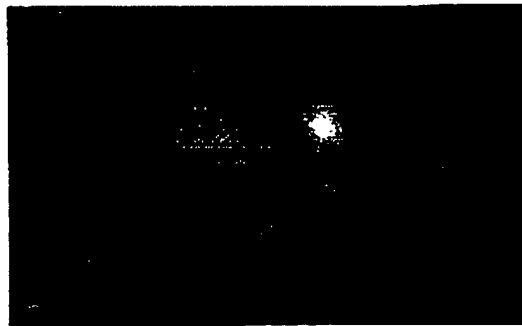

**Pump energy = 17.5 mJ**

**Soliton-Locking for Stable Parametric Sources**

It is clear that very clean spatial profiles are available at relatively low pulse energies. Furthermore, measurements of the shot-to-shot pulse energy reproducibility was excellent, another feature of the soliton-locking process. However, at high input pulse energies two output spots began to form, surrounded by a great deal of stray scattering. This regime of operation was totally unexpected. We believe that it was caused by problems in the laser optics. Inspection of the laser amplifier rod revealed burned coatings which probably led to distortions of the laser wavefront. Under strong parametric amplification, in our case four passes, this distortion can lead to the formation of multiple solitons, and competition between them for the power. This we believe is responsible for the formation of multiple spots, and the competition between them that leads to radiation losses.

The rod and its flashlamp housing was returned to Continuum for repair (and Continuum lost the housing). We now have the refinished rod and a new housing back and plan to continue this investigation.

In summary, due to a complicated sequence of events we were unable to perform the research that we expected in the last nine months. The equipment acquired specifically for the study of soliton-locking is just now operational. Because of these problems, a second system based on a 30 psec laser was built to investigate independently soliton-locking in an OPG/OPA system. It has been operated successfully in the soliton-locking regime. However, damage to the laser amplifier rod was found and has now been fixed. The research continues.