

AECD - 2003

UNITED STATES ATOMIC ENERGY COMMISSION

24785

TETRAMETHYL LEAD FILLED GEIGER COUNTERS

by

H. A. Glassford
R. L. Macklin

RECEIVED BY
SHELL & TUBULAR
THERMAL DIVISION

DISSEMINATION STATEMENT A
Approved for public release
Distribution Unlimited

Columbia University

NOV 15 1948

19970310 090

Date of Manuscript: July 1944
Date Declassified: May 24, 1948

Its issuance does not constitute authority
for declassification of classified copies
of the same or similar content and title
and by the same authors.

Technical Information Division, Oak Ridge Operations

AEC, Oak Ridge, Tenn., 11-5-48--850-18462

Printed in U.S.A.
PRICE 10 CENTS

DTIC QUALITY INSPECTED 1

TETRAMETHYL LEAD FILLED GEIGER COUNTERS

By H. A. Glassford and R. L. Macklin

The increased demand for Geiger counters during the past two years has led to the investigation, in these laboratories, of numerous gasses and counter filling techniques. Prior to 1942 the major part of these investigations was concerned with argon and alcohol filled counters. Experience has indicated that these counters do not entirely meet reasonable stringent operational requirements. In order to obtain even a small percentage of satisfactory counters, highly skilled and experienced personnel was required. The expanding use of counters called for a straightforward filling technique which would produce reliable counters and could be handled by less experienced personnel.

Early in 1942 a new counter filling technique was described to one of the authors by A. S. Keston.* This method consisted of filling counters with tetramethyl lead vapor to pressures from 1 to 2 cm Hg. The technique is simple and yields a very high percentage of good counters which are stable over long periods, are not sensitive to moderate temperature changes and have wide, flat plateaus. They are fast, self-quenching counters and require only a simple single stage amplifier, the output of which can be fed directly into a scaling circuit. This report will describe several types of counters, a suitable amplifier circuit, and the filling technique, in detail.

A simple, rugged system for filling counters with tetramethyl lead is shown diagrammatically in Figure 1 and the essential parts of the system are shown in the photograph, Figure 2.

Several variations in filling procedure have been found to give equally good results. A simple, yet rapid technique which has been used at these laboratories is outlined in the Appendix. Normally, flushing with small quantities of the filling material is employed to remove the last traces of air. Techniques including a baking cycle or outgassing by means of high voltage discharge have not been found to yield significantly better results. The counter tubes are usually filled to a pressure of 1.8 cm of mercury. The use of moderately lower or higher pressures decreases or increases the typical operating voltages.

The handling of tetramethyl lead requires certain precautions, due to its toxic nature. The chief danger is from the liquid as the amounts of gas which might be accidentally diffused into the atmosphere by breaking even the largest counters is small compared with dangerous doses. The actual filling should be carried out in a well ventilated hood. Only one to two cc of the liquid are kept in the filling system reservoir, which has an extra guard tube to catch the liquid in case of breakage. Filling the reservoir is the most dangerous operation but it need be done but infrequently as at least twenty counters can normally be filled before emptying the reservoir. A simple, safe method is to transfer the liquid from its container to the reservoir in a medicine dropper type of pipette, which is then immediately rinsed in a beaker of alcohol.

In case any of the liquid should come in contact with the skin it is advisable to rinse immediately with copious quantities of water. Rubber gloves should be worn to protect workers lacking experience

*Keston, A. S., Rev. Sci. Inst. 14:293-5 (1943).

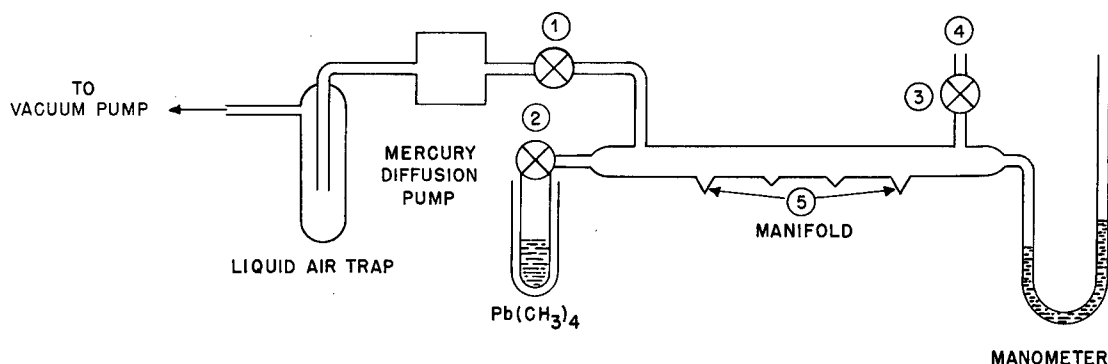

Figure 1. Schematic diagram of filling system.

in handling chemicals if they are to transfer the liquid tetramethyl lead to the filling systems reservoir. All stopcocks are lubricated with compounds especially designed for non-aqueous solvents such as Eimer and Amend's "Nonaq". This prevents the accumulation of dissolved tetramethyl lead within the system. When shutting down the system it is advisable to isolate the contents of the liquid air trap with pinch clamps or other valves so that no toxic vapors can escape when the trap warms up.

Two counters, types BC-1 and BC-2 suitable for the detection of beta particles are shown in Figures 3 and 4. These counters have the same characteristics, their only difference being the smaller overall diameter of BC-2 which is obtained by putting the cathode lead parallel to the central wire. This type of construction is useful in portable mountings, where it is desirable to keep the size to a minimum.

Two sizes of gamma counters are shown in Figures 6, 7, and 9. Type GC-3, the smaller of the two, is particularly useful in applications where compactness is required rather than high sensitivity. Type GC-2 is used for the detection of weaker radiations while even larger counters of the same general construction have been made to further increase the sensitivity.

Silver electrode surfaces yield very good results and are convenient from the fabrication viewpoint. In the thin wall, all glass beta counters a very thin silver electrode is formed by the silvering on glass process. Counters of this type have been employed in these laboratories for many years.* The gamma counter electrodes can be made of easily worked base metals, soldered, welded, or machined, and then electroplated with silver. The bright silver surfaces formed by these methods need no further treatment before the counters are filled.

Considerable work with the more active metals has led to counters with good initial characteristics which, however, rapidly disappeared as the counters were used. There is some data to indicate that the noble metals including mercury are satisfactory as electrode surfaces.

The counters should not be exposed to light for extended periods. Decomposition of the tetramethyl lead occurs in light and will interfere with the excellent self-quenching characteristics of the counters within a short time. Counters are usually housed in a lead shield to reduce the background count due to stray radiations. Such shields also provide adequate light protection. Should some applications call for counters being used without shields, it is suggested that they be given a thin coat of opaque lacquer.

A suitable simple amplifier circuit frequently used is shown in Figure 12. Proper operating conditions are obtained by driving the amplifier tube to saturation. The cathode bias should be adjusted with the counter operating at about two hundred volts above threshold. This adjustment need not be

* Manufactured by Eck and Krebs New York, N, Y.

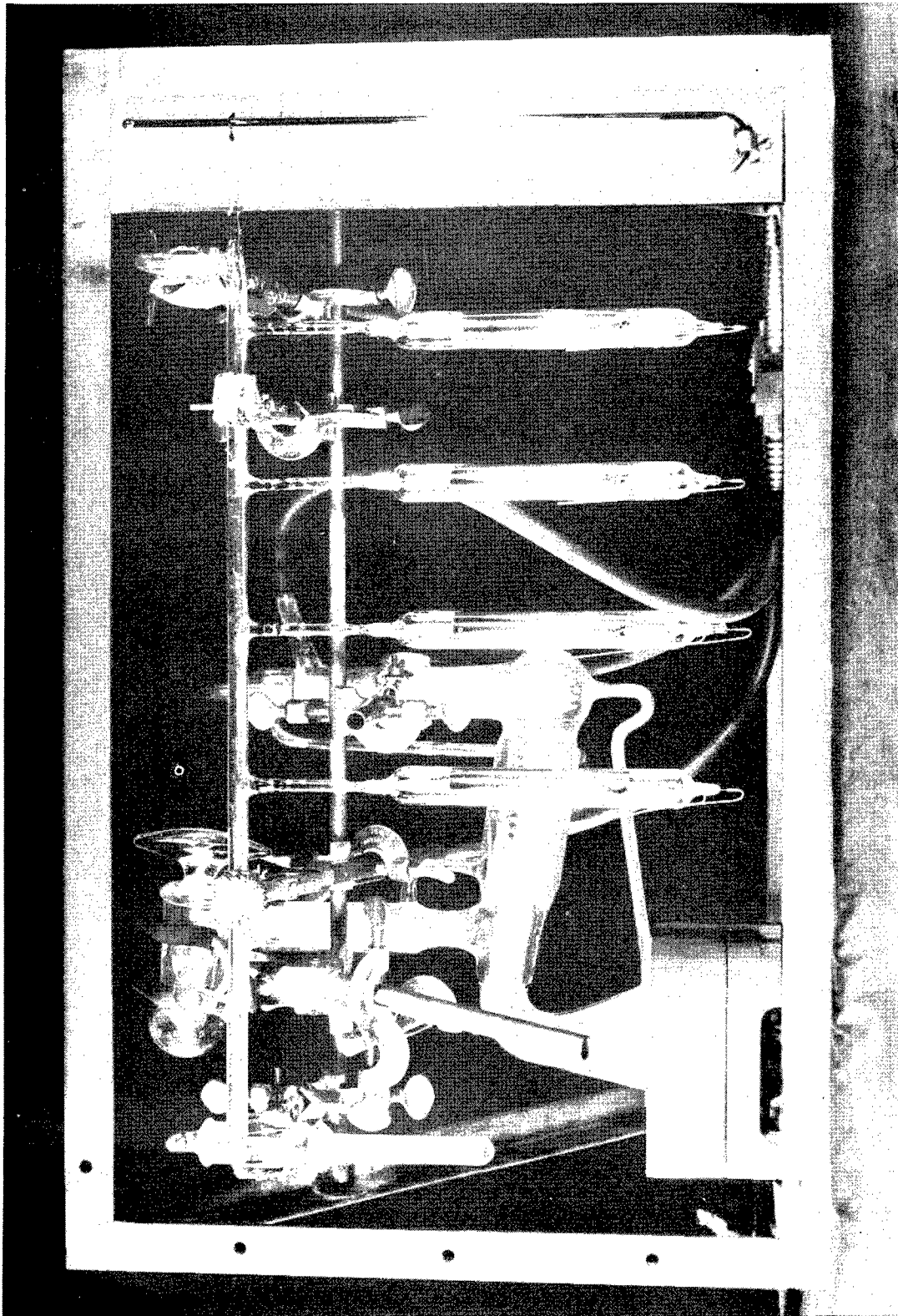

Figure 2. Essential parts of the filling system.

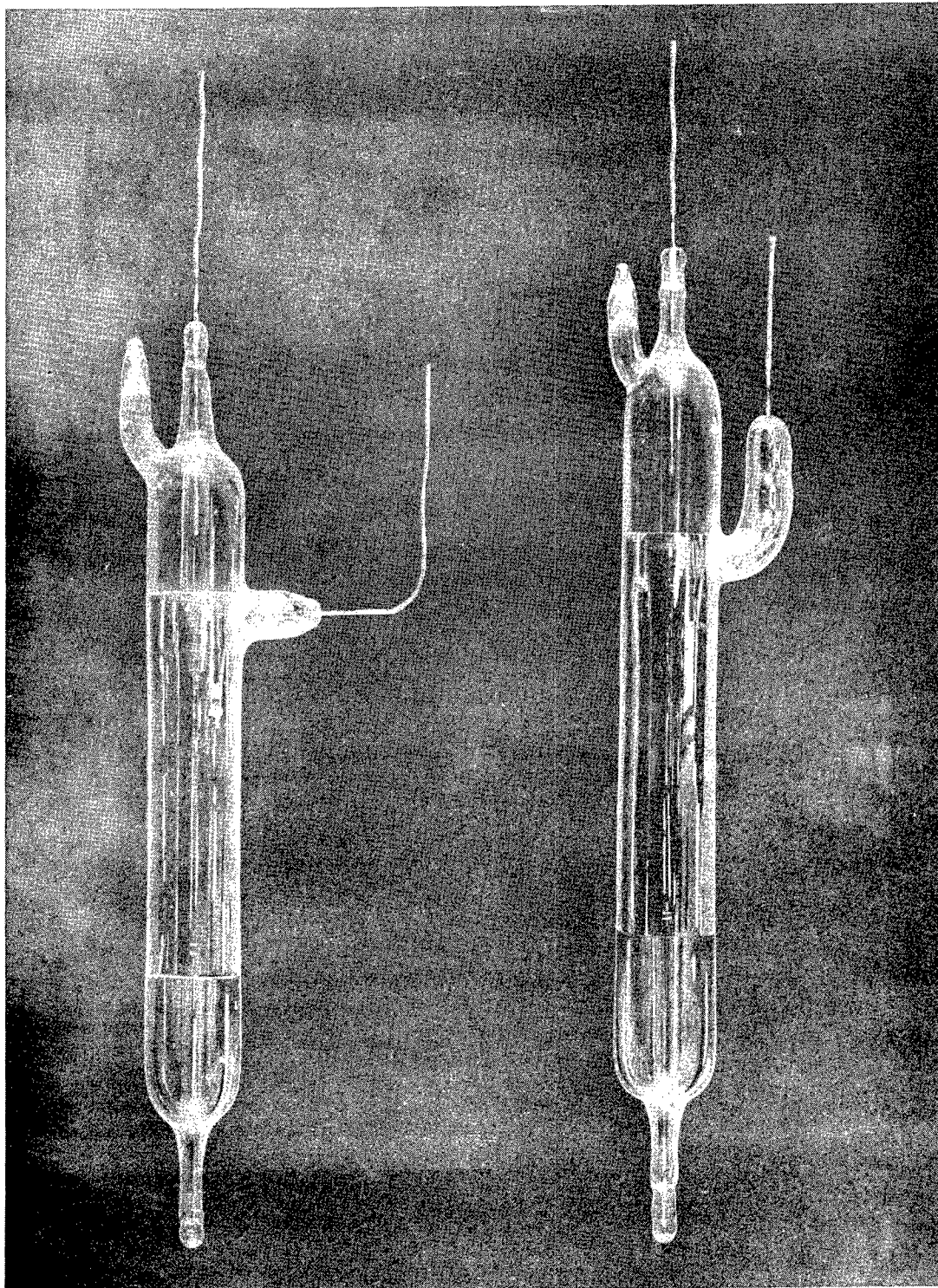
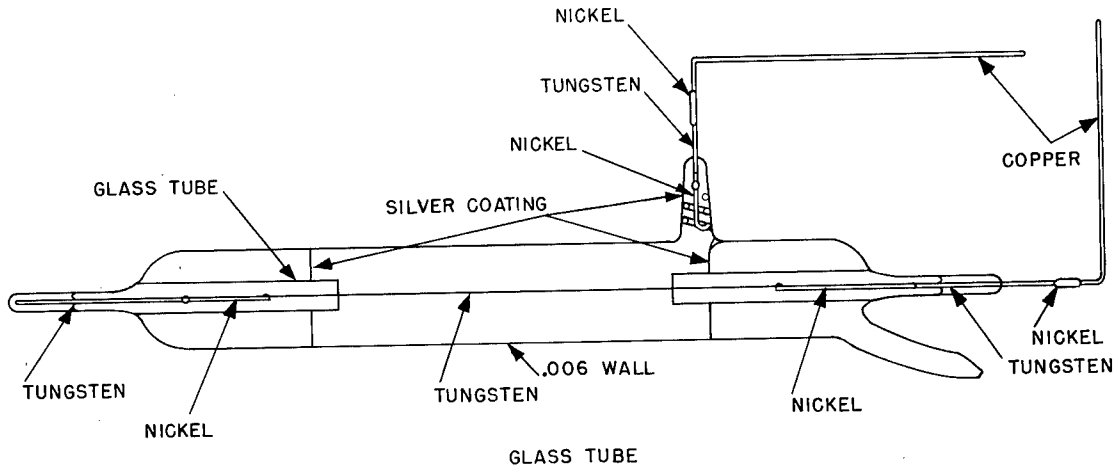

Figure 3. Beta particle counters. Top - Type BC-1 Bottom - Type BC-2



Specifications

Envelope-Drawn From 19 mm Pyrex Glass Tubing
 Wall Thickness - Approximately .006
 Cathode-Deposited Silver

Central Wire-Tungsten .004 dia
 Gas Filling - Tetramethyllead
 Pressure - 1.8 cm Hg.

Typical Operating Characteristics

Voltage Range - 1400-2000 Volts
 Plateau - 1480-1800 Volts

Figure 4. Beta counter BC-1.

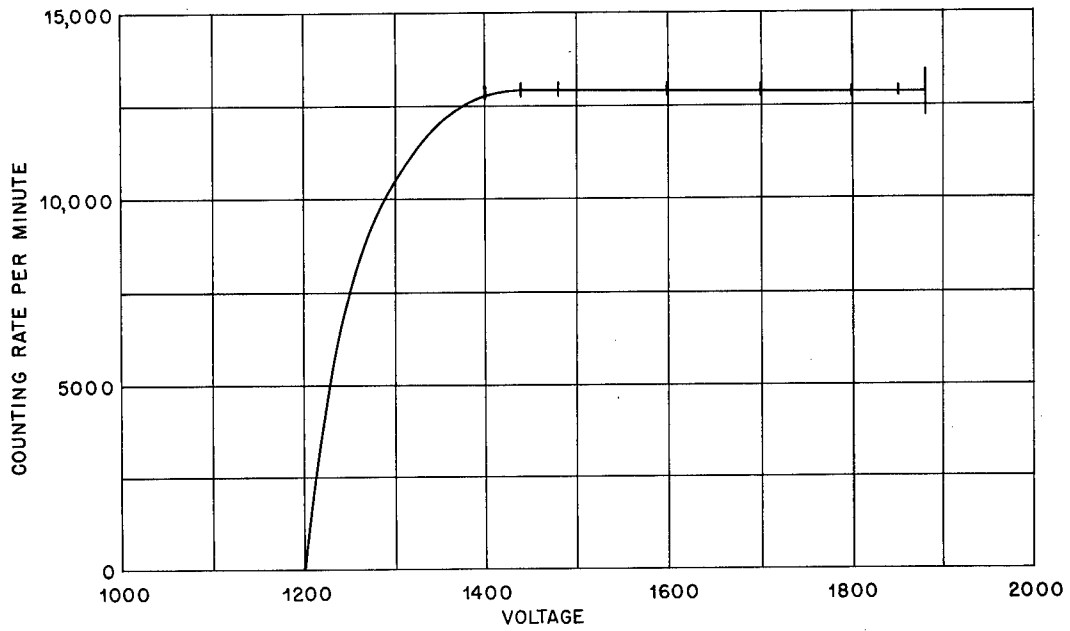

Figure 5. Typical characteristics, beta counter BC-1.

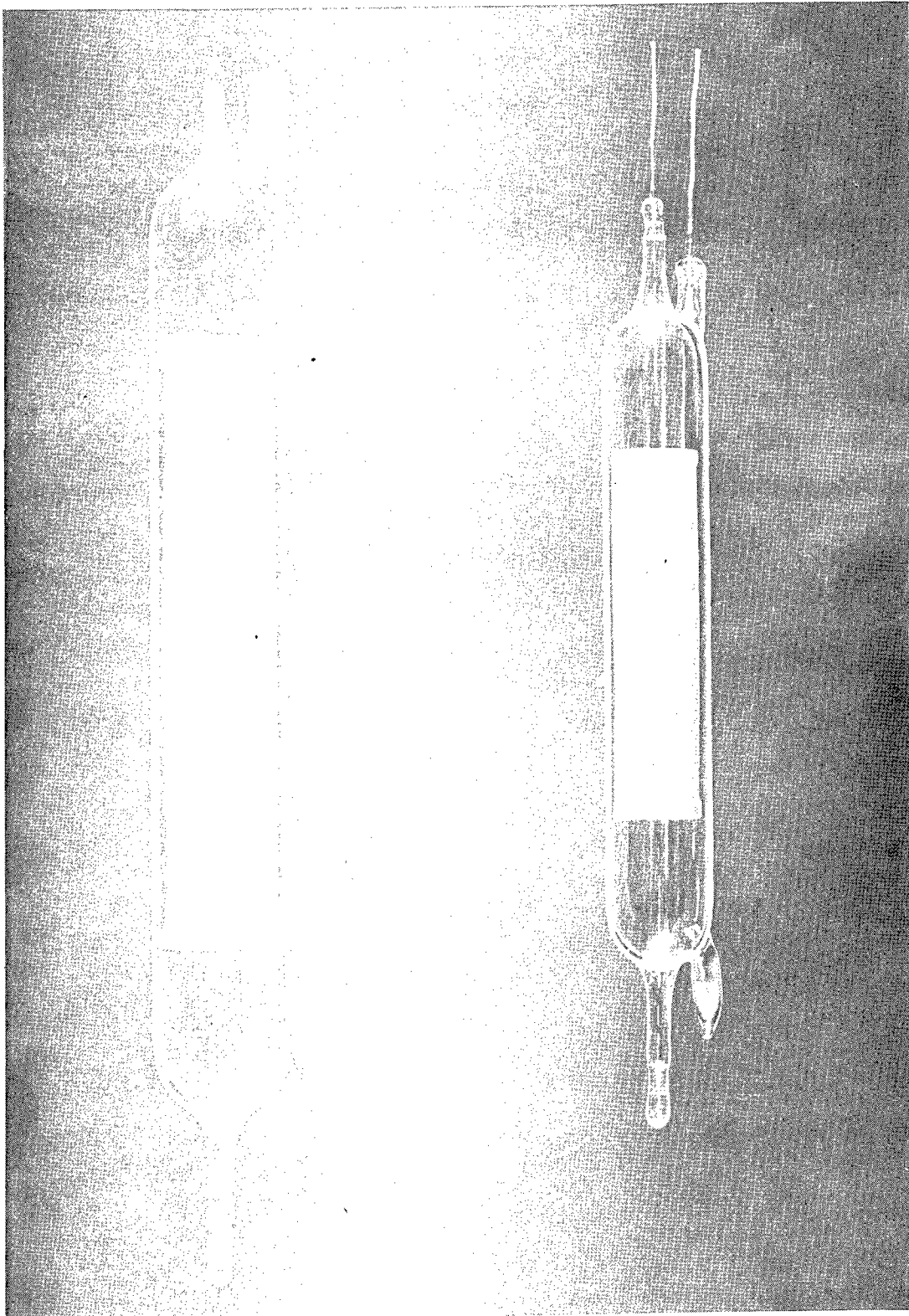
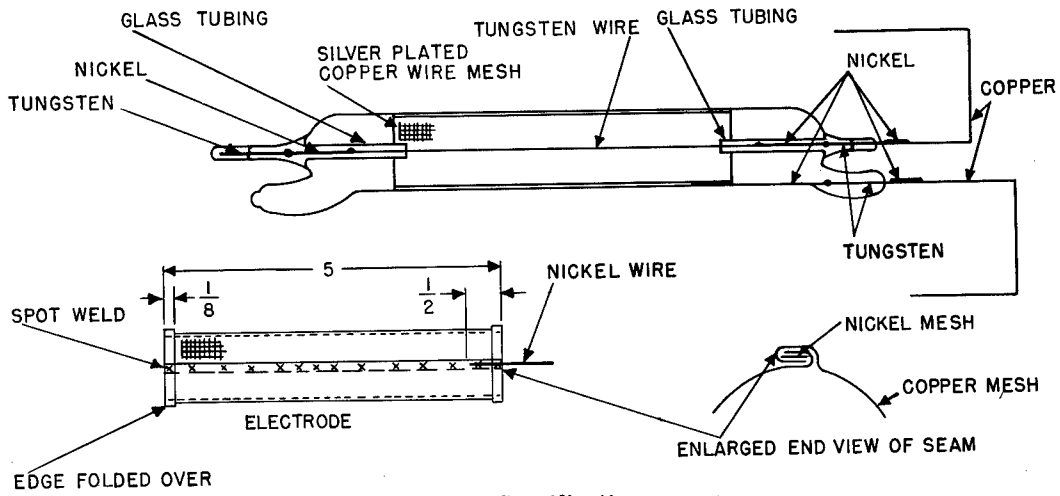

Figure 6. Gamma counters. Top - Type GC-2 Bottom - Type GC-3



Specifications

Envelope-28 mm Pyrex Glass Tubing
 Wall Thickness - .067"

Central Wire - Tungsten .004 dia
 Gas Filling - Tetramethyllead
 Pressure - 1.8 cm Hg.

Typical Operating Characteristics

Voltage Range - 1200-2000+Volts
 Plateau- 1440-1800 Volts

Figure 7. Gamma counter GC-2.

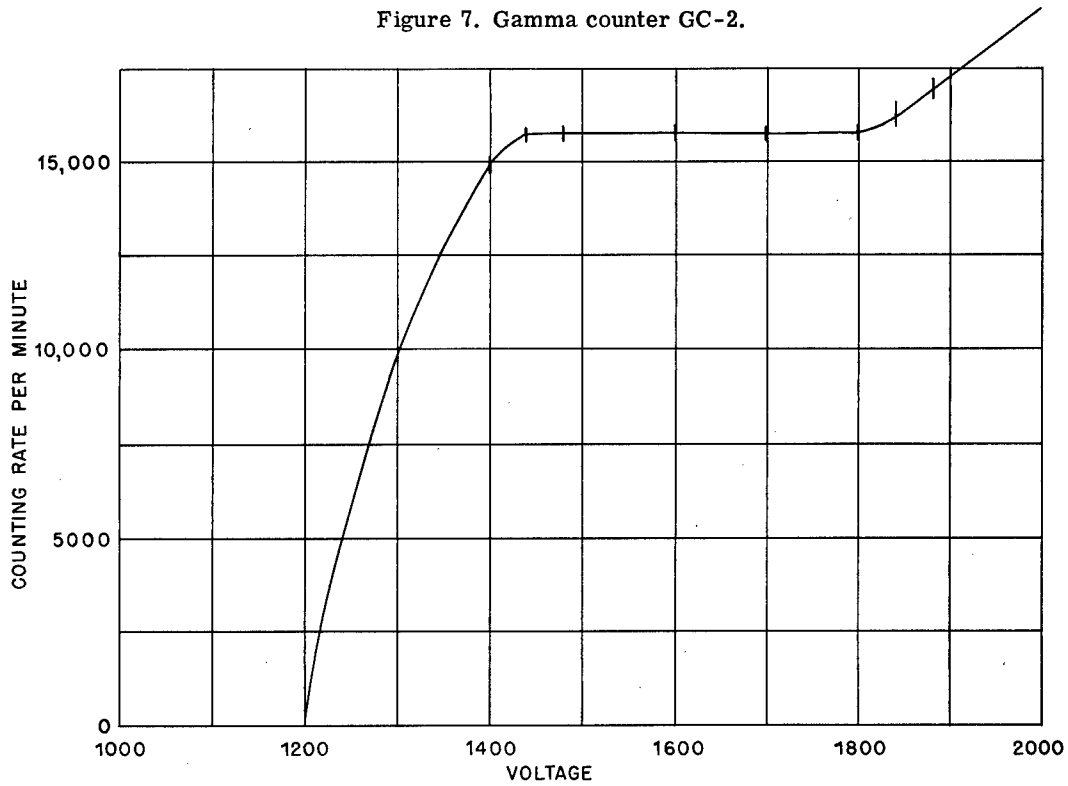
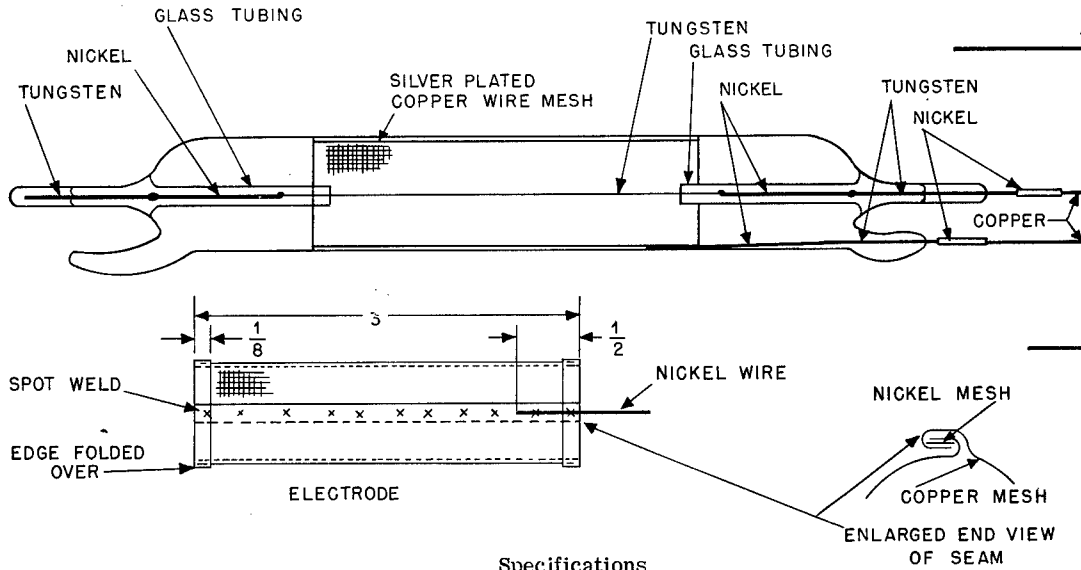

Figure 8. Typical characteristics, gamma counter GC-2.



Specifications

Envelope-22 mm Pyrex Glass Tubing
 Wall Thickness .059"

Central Wire-Tungsten .004 dia
 Gas Filling-Tetramethyllead
 Pressure-1.8 cm Hg.

Typical Operating Characteristics

Voltage Range - 1200-1850 Volts
 Plateau - 1480-1680 Volts

Figure 9. Gamma counter GC-3.

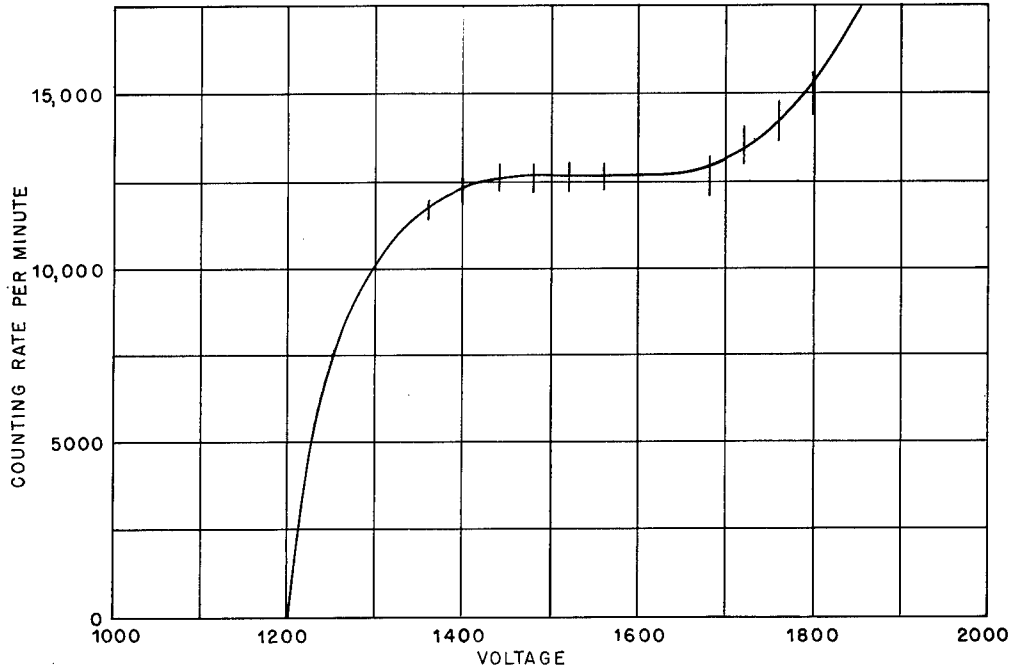

Figure 10. Typical characteristics, gamma counter GC-3.

changed over the complete operating voltage range of the counter. Resistor R in series with the central wire and the high voltage supply can be from two to twenty megohms or even higher. The higher values give longer tube life.

Typical graphs of counting rate with a fixed standard source versus voltage applied across the counter are given in Figures 5, 8, and 10. Threshold voltages given are those found with the input circuit shown and the associated scaling circuit or rate meter employed. Some small pulses can be seen on an oscilloscope screen with the counter operating two hundred volts or more below such a threshold. The plateaus obtained are generally extremely flat and two or three hundred volts long.

Life tests have been run on counters of the BC-1 type. Frequent redeterminations of the counter characteristics during a forty day run at a high counting rate revealed some initial aging effect, followed by a long period of very stable operation. For this reason, it has been found advisable to age counters for a few million counts before placing them in service. Figure 11 represents tube characteristics at various stages of a life test during which the voltage was kept near the center of the plateau region. Operating lives in excess of 10^9 counts should be obtained.

The simplicity of the tetramethyl lead filling techniques can perhaps best be shown by the time required to fill counters; four counters can be attached to the system, pumped, filled, checked for plateaus on a rate meter, and sealed off in thirty minutes. A large number of tetramethyl lead counters have now been used over a period of two years. The operating records of these counters have been the most satisfactory of the various types which have thus far been tested.

The tetramethyl lead filling technique is being applied to various other types of counter construction. Operating data on these types is now being accumulated and their characteristics will be covered in a subsequent report. This further work is being conducted by Chien-Shiung Wu and Charlotte L. Meaker.

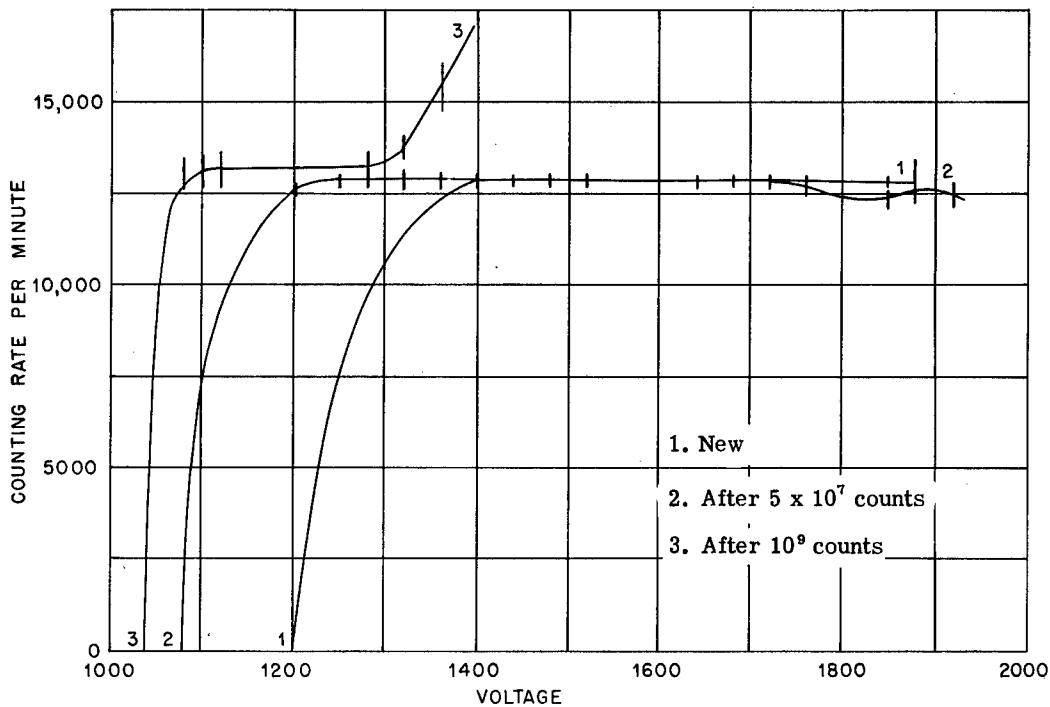

Figure 11. Life test for beta counter BC-1.

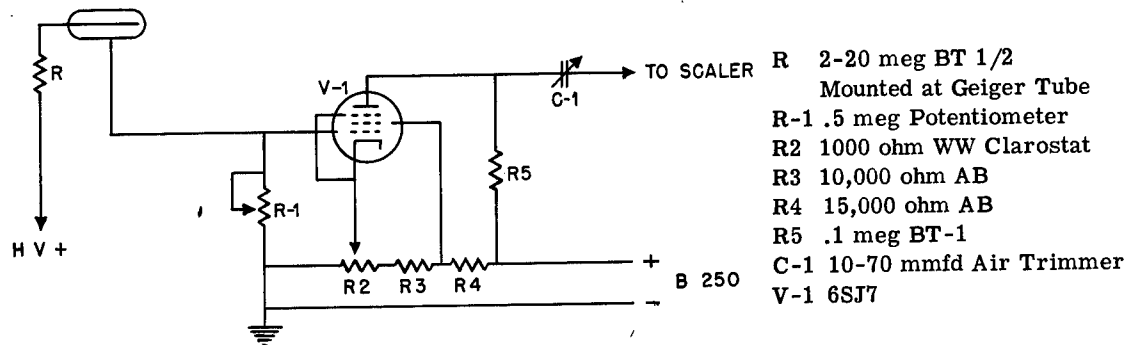

Figure 12. Typical input circuit of the Geiger counter amplifier.

APPENDIX

Detailed Filling Procedure

- 1) Turn on the blower for the hood and fill the thermos flask with liquid air prior to placing it around the cold trap.
- 2) Turn on the pumps and the cooling water.
- 3) Making sure that stopcocks (1) and (2) are closed, connect a glassblower's mouth tube to the air vent (4) and slowly open stopcock (3).
- 4) Attach the counter tubes to be filled to the manifold outlets (5).
- 5) Close (4) and open (1). After a few moments check the glass seals at (5) and repair any holes. (If the reservoir has just been filled, open both (1) and (2) for approximately ten seconds to sweep out any air trapped in the reservoir).
- 6) After two to five minutes pumping or when the bright violet spark discharge in the manifold has faded to a light blue, close (1) and open (2) until the pressure reads about one centimeter of mercury. Note: Do not use the spark discharge while tetramethyl lead vapor is in the system as this leads to tarry deposits.
- 7) Next open (1) for about one minute and then close.
- 8) Open (2) until the pressure again reads about 1 cm.
- 9) Repeat Step 7.
- 10) Admit the final filling of about 1.8 cm of tetramethyl lead by manipulating the reservoir stopcock (2) and then record the manometer reading.
- 11) Optional—Check the operating characteristics of the counters briefly on a rate meter and record the results.
- 12) Seal off the counters.
- 13) Open (1) briefly, then close it and slowly open (3). If more tubes are to be filled immediately start in again at Step 4.
- 14) Isolate the liquid air trap with pinch clamps.
- 15) Shut off the pumps and the cooling water.

END OF DOCUMENT