



**US Army Corps
of Engineers**

Waterways Experiment
Station

Technical Report ITL-97-1
February 1997

Flaw Detection Practices for Steel Hydraulic Structures

by Joseph A. Padula

RECEIVED
DISTRIBUTION STATEMENTS
UNCLASSIFIED
AUTHORITY
DATE
BY
PERFORMING ORGANIZATION NAME(S) AND ADDRESS(ES)
US ARMY CORPS OF ENGINEERS
WATERWAYS EXPERIMENT STATION
8705 GREENBERRY DRIVE
VICKSBURG, MISSISSIPPI 39180-6346
PERFORMING ORGANIZATION REPORT NUMBER
ITL-97-1
AUTHORITY
DATE
BY
PERFORMING ORGANIZATION NAME(S) AND ADDRESS(ES)
US ARMY CORPS OF ENGINEERS
WATERWAYS EXPERIMENT STATION
8705 GREENBERRY DRIVE
VICKSBURG, MISSISSIPPI 39180-6346
PERFORMING ORGANIZATION REPORT NUMBER
ITL-97-1
AUTHORITY
DATE
BY

Approved For Public Release; Distribution Is Unlimited

19970311 126

DTIC QUALITY INSPECTED 3

Prepared for Headquarters, U.S. Army Corps of Engineers

The contents of this report are not to be used for advertising, publication, or promotional purposes. Citation of trade names does not constitute an official endorsement or approval of the use of such commercial products.



PRINTED ON RECYCLED PAPER

Technical Report ITL-97-1
February 1997

Flaw Detection Practices for Steel Hydraulic Structures

by Joseph A. Padula

U.S. Army Corps of Engineers
Waterways Experiment Station
3909 Halls Ferry Road
Vicksburg, MS 39180-6199

Final report

Approved for public release; distribution is unlimited

DTIC QUALITY INSPECTED 3

Prepared for U.S. Army Corps of Engineers
Washington, DC 20314-1000



**US Army Corps
of Engineers
Waterways Experiment
Station**

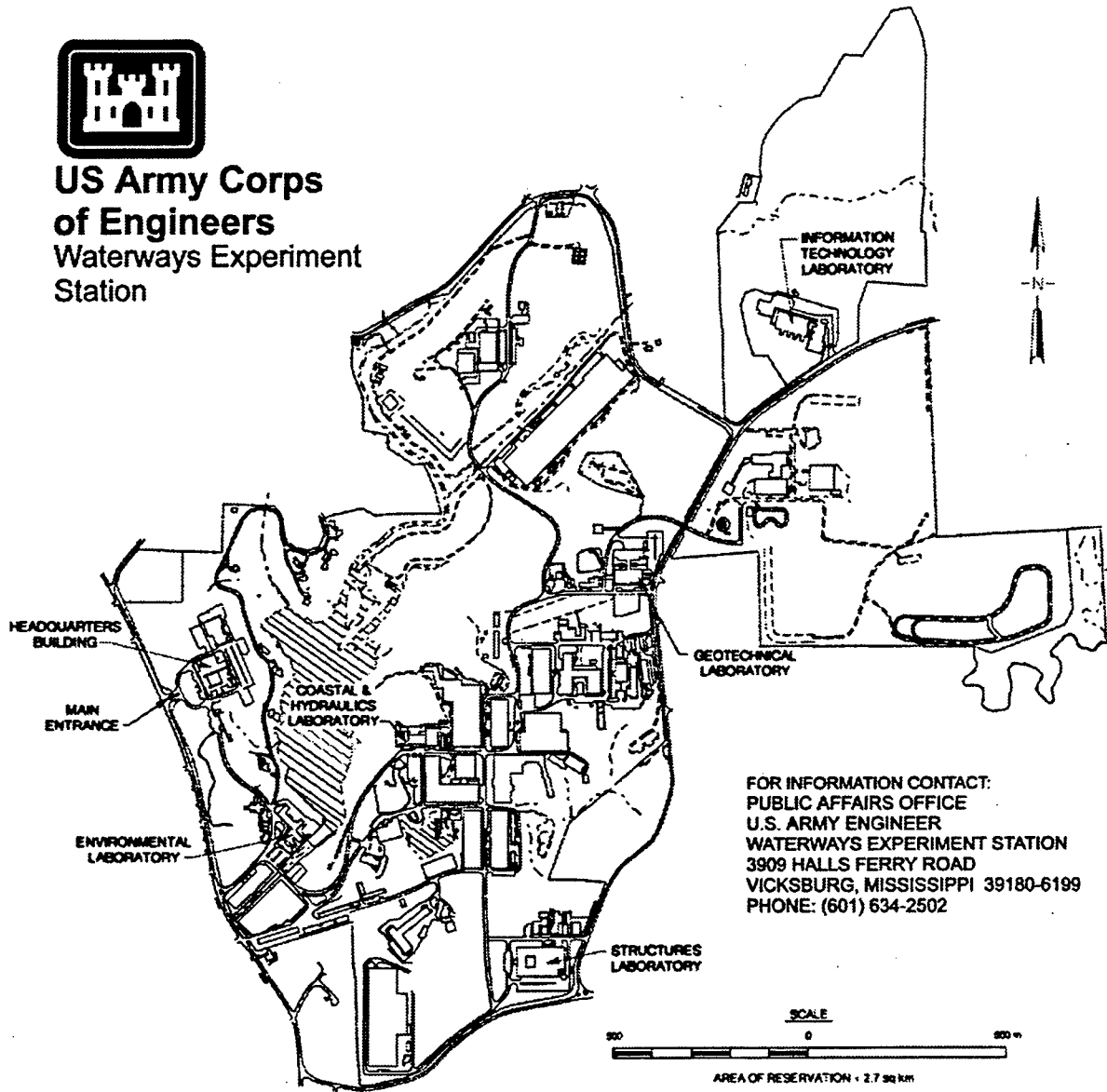

Waterways Experiment Station Cataloging-in-Publication Data

Padula, Joseph A., 1955-

Flaw detection practices for steel hydraulic structures / by Joseph A. Padula ; prepared for U.S. Army Corps of Engineers.

43 p. : ill. ; 28 cm. -- (Technical report ; ITL-97-1)

Includes bibliographic references.

1. Hydraulic structures -- Design and construction. 2. Hydraulic structures -- Inspection. 3. Non-destructive testing. 4. Steel, Structural -- Testing. I. United States. Army. Corps of Engineers. II. U.S. Army Engineer Waterways Experiment Station. III. Information Technology Laboratory (U.S. Army Engineer Waterways Experiment Station) IV. Title. V. Series: Technical report (U.S. Army Engineer Waterways Experiment Station) ; ITL-97-1. TA7 W34 no.ITL-97-1

Contents

Preface	vi
1—Introduction	1
Discontinuities and Structural Performance	1
Fracture	1
Fatigue	2
Reliability and Inspection	3
2—Imperfections and Discontinuities in Steel Structures	5
Terminology	5
Imperfections	6
Manufacturing imperfections	6
Weld and fabrication discontinuities	7
Service-related imperfections	8
3—Nondestructive Test Methods	9
Visual Inspection	9
Equipment and materials	9
Procedure	10
Effectiveness	10
Liquid Penetrant Inspection	10
Equipment and materials	11
Procedure	12
Effectiveness	13
Magnetic Particle Inspection	13
Equipment and materials	14
Procedure	17
Effectiveness	17
Radiographic Inspection	17
Materials and equipment	19
Procedure	19
Effectiveness	20
Ultrasonic Inspection	20
Equipment and materials	21
Procedure	23
Effectiveness	24

Eddy Current Inspection	24
Equipment and materials	25
Procedure	25
Effectiveness	26
Acoustic Emission Inspection	26
4—Inspection Strategies	28
Selection of Appropriate Inspection Methods	28
Personnel Qualification	29
Identification of Critical Areas	30
5—Evaluation of Flaws	32
Acceptance Criteria for Weld Discontinuities	32
Fracture and Fatigue Evaluation	33
References	34

SF 298

List of Figures

Figure 1. Qualitative relationship between stress level, critical flaw size, and fracture toughness	2
Figure 2. Qualitative relationship between fatigue life, flaw size, and stress range	3
Figure 3. Effect of inspection on flaw size	4
Figure 4. Effect of inspection and remedial action on number of flaws	4
Figure 5. Flaw detection of a surface flaw with liquid penetrant	11
Figure 6. Magnetic particle indication at a surface discontinuity	14
Figure 7. Electromagnetic yoke shown with magnetic field	15
Figure 8. Prod contacts shown with magnetic field	16
Figure 9. Effect of direction of radiation on indications of discontinuities	18
Figure 10. Block diagram of a pulse echo ultrasonic inspection system	22

Figure 11. Scanning path of ultrasonic transducer for weld inspection	23
Figure 12. Common types of inspection coils	25

Preface

This report is an introduction to flaw detection practices for steel hydraulic structures. It was prepared for and funding was provided under the Operations and Maintenance Reliability Models for Major Rehabilitation Research Program at the U.S. Army Engineer Waterways Experiment Station (WES). The work was coordinated with Headquarters, U.S. Army Corps of Engineers (HQUSACE), by Mr. Anil Chowdury of the Operations Division, Directorate of Civil Works, and Messrs. Don Dressler and Jerry Foster of the Engineering Division, Directorate of Civil Works. The work was performed under the direction of Dr. Mary Ann Leggett, Computer-Aided Engineering Division (CAED), Information Technology Laboratory (ITL), WES. The author of the report is Mr. Joseph A. Padula, ITL. The work was performed under the general supervision of Mr. H. Wayne Jones, Chief, CAED, and Dr. N. Radhakrishnan, Director, ITL.

At the time of publication of this report, Director of WES was Dr. Robert W. Whalin. Commander was COL Bruce K. Howard, EN.

1 Introduction

A rational approach to maintaining an acceptable level of reliability over the service life of a structural system typically requires a program of periodic inspection, maintenance, and repair. This is especially true for civil works structures where inspection, maintenance, and repair operations are not precluded by the operating environment or structural configuration or by economic considerations.

The reliability of a structure is related to one of a number of possible modes of unsatisfactory performance. Failure modes usually considered include general yielding, buckling or instability, serviceability criteria, corrosion and wear, subcritical crack growth (fatigue), and unstable crack growth (fracture) usually resulting in partial or complete failure of a member. In recent years, it has become apparent that fatigue and fracture represent real and significant modes of unsatisfactory performance for steel structures. Fatigue or fracture of a structural member will, in most cases, be directly attributable to the presence of a discontinuity or other type of imperfection. Detection of these imperfections is critical in evaluating the reliability and remaining service life of steel structures and is the primary focus of this report.

Discontinuities and Structural Performance

Fracture mechanics theory provides a means of quantifying the effect of a discontinuity on fracture and fatigue of a structural member. Here, the effect of imperfections on structural performance is presented with qualitative illustrations of some fundamental relationships derived from fracture mechanics. More detailed discussion of fracture mechanics and fatigue can be found in a number of texts, for example, Barsom and Rolfe (1987), or in ETL 1110-2-346 and ETL 1110-2-351.

Fracture

Fracture is defined as unstable (rapid) crack propagation resulting in complete or partial failure of a structural component. The factors that contribute to the fracture include material fracture toughness, thickness of the material, temperature, the rate of applied loading, applied stress level,

residual stresses, geometry of the component or detail as it relates to stress concentration in the vicinity of an imperfection, and size, location and orientation of an imperfection or flaw. Effective fracture prevention requires consideration of each of these factors. However, there are three primary factors that control susceptibility to fracture in a given application: material fracture toughness, the tensile stress level including residual stress and stress concentration, and the size of an existing discontinuity.

For given service conditions, the stress level, material fracture toughness, and the critical flaw size (or the size of a flaw that will initiate unstable crack growth or fracture) are related as shown in Figure 1. This relationship has significance in both the design of new structures and maintenance of existing structures. In the design of a new structure, all three parameters can be controlled. Stress levels are limited by design criteria that are traditionally based on strength or stability considerations but can be controlled by considerations of fracture prevention. Fracture toughness can be controlled through use of material appropriate for particular service conditions, although ensuring that specific requirements are met can be difficult. Finally, flaw size is controlled through inspection and quality control. However, in maintaining existing structures, the material and stress levels are established, and the primary means of fracture control is to ensure that flaws do not exceed the critical flaw size. Obviously, minimizing the number and size of flaws in a structure through a program of inspection, maintenance, and repair will reduce the probability of fracture.

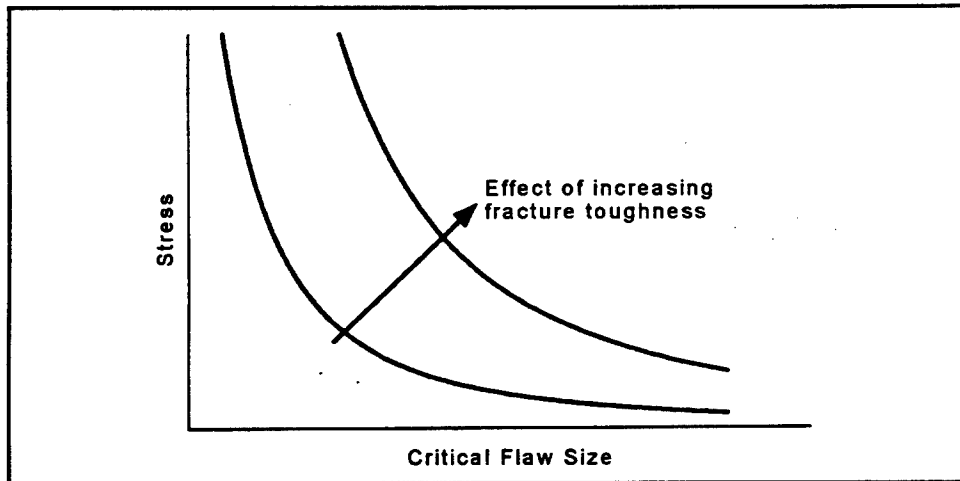

Figure 1. Qualitative relationship between stress level, critical flaw size, and fracture toughness

Fatigue

Fatigue is the initiation and propagation of cracks resulting from cyclic loading. In contrast to fracture, fatigue crack propagation is stable and occurs over a large number of cycles of loading. However, fatigue crack propagation can result in a crack reaching critical size, resulting in a fracture. Fatigue life is defined as the number of cycles of loading to failure. For structural steel components, the dominant factors that affect the fatigue

life are the fluctuation in the magnitude of the localized stress and crack or flaw size. For convenience in analysis and design, the number of load cycles and the type of detail, which reflects the severity of the local stress concentration, are commonly used to quantify the allowable fluctuation in the stress, or stress range.

Fracture mechanics principles have also been applied to describe the relationship between fatigue life, crack size, and localized stress fluctuation. For a given detail, the relationship between fatigue life, stress range, and crack size is shown qualitatively in Figure 2.

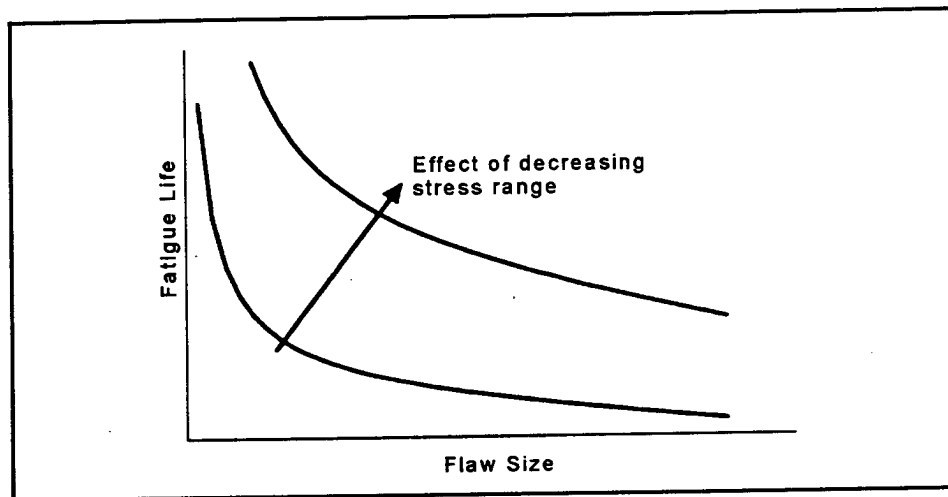

Figure 2. Qualitative relationship between fatigue life, flaw size, and stress range

As illustrated in Figure 2, the crack size has a significant effect on the remaining fatigue life of a structural component. Obviously, detection and elimination of flaws of significant size are required to prevent fatigue failures. Similarly, determination of remaining fatigue life of in-service structures is also dependent on knowledge of existing flaw sizes. For a structure subjected to fatigue loading, inspection is an essential component of fatigue control.

Reliability and Inspection

The purpose of inspection in a maintenance or quality assurance program is to improve structural safety and reliability. For purposes of fracture and fatigue control in structures, inspection provides data on the presence of significant flaws so that they may be eliminated through repair or removal from service.

The size of an existing flaw in a structure or component can be represented as a random variable with an associated probability distribution function. The result of inspection and remedial action is qualitatively illustrated in Figure 3. The actual effect will, of course, depend on the thoroughness of the inspection and the inspection methods employed.

Similarly, the number of discontinuities or flaws in a structure can be represented as a random variable, and a similar effect from inspection and remedial action is observed as shown in Figure 4.

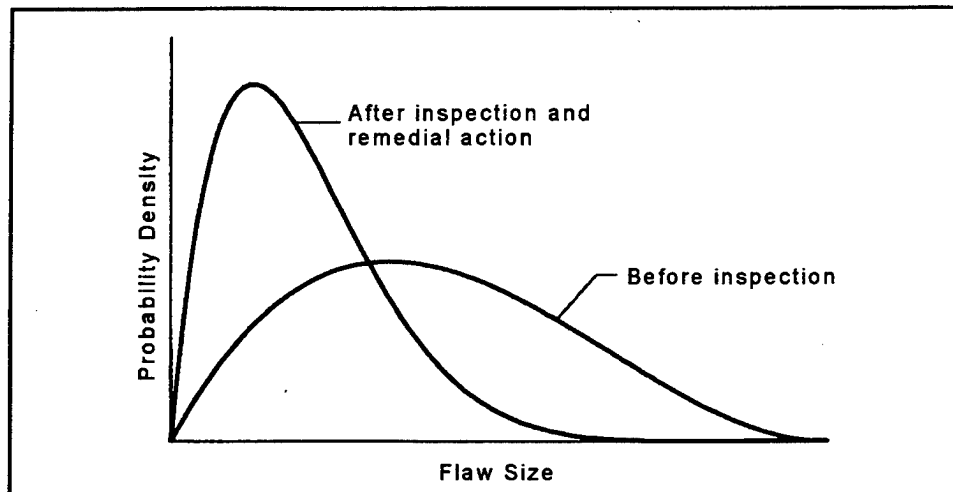

Figure 3. Effect of inspection on flaw size (after Committee (1982))

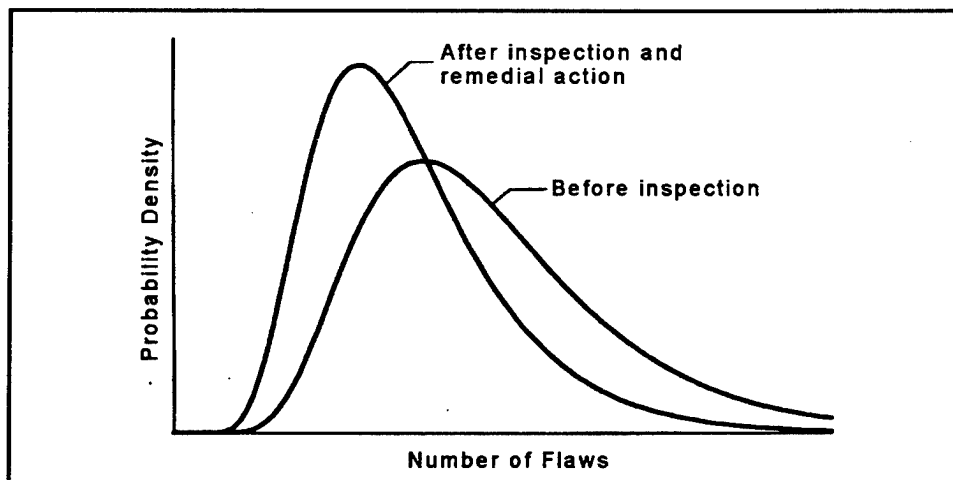

Figure 4. Effect of inspection and remedial action on number of flaws

Clearly, inspection and consequent remedial action will result in structures with fewer and smaller imperfections and, consequently, greater reliability. For newly fabricated structures, flaw detection must be an integral part of a quality assurance program. The importance of inspection is even greater for in-service structures since operation and maintenance activities, fatigue loading, and even well intended repairs can produce or enlarge flaws or cracks.

2 Imperfections and Discontinuities in Steel Structures

The primary goal of inspection is to identify the location, type, and magnitude of structural imperfections or flaws. This information is required for effective implementation of maintenance and repair programs for in-service structures as well as quality assurance of newly fabricated structures. As discussed in Chapter 1, the reduction in the number and size of imperfections will improve the reliability of a structure.

Effective inspection requires knowledge of the expected type of imperfections, where they can be expected to be found, and the appropriate methods for detecting and characterizing them. The types of imperfections commonly encountered in steel structures are discussed in the following sections.

Terminology

Various types and sizes of imperfections exist in all structural materials. In addition, flaws may be introduced during fabrication, particularly for welded structures. Imperfections can also be introduced during operation under extreme as well as normal service conditions.

Prior to discussing imperfections and nondestructive test methods for detecting and characterizing them, general terminology should be established. The following definitions are taken from "Standard Terminology for Nondestructive Examinations" (American Society for Testing and Materials (ASTM) 1994a).

Defect. One or more flaws whose aggregate size, shape, orientation, location, or properties do not meet specified acceptance criteria and are rejectable.

Discontinuity. A lack of continuity or cohesion; an intentional or unintentional interruption in the physical structure or configuration of a material or component.

Evaluation. A review, following interpretation of the indications noted, to determine whether they meet specified acceptance criteria.

Flaw. An imperfection or discontinuity that may be detectable by nondestructive testing and is not necessarily rejectable.

Imperfection. A departure of a quality characteristic from its intended condition.

Indication. Evidence of a discontinuity that requires interpretation to determine its significance.

Interpretation. The determination of whether indications are relevant or nonrelevant.

Nonrelevant indication. An nondestructive test (NDT) indication that is caused by a condition or type of discontinuity that is not rejectable. False indications are nonrelevant.

Relevant indication. An NDT indication that is caused by a condition or type of discontinuity that requires evaluation.

Imperfections

Imperfections are often classified according to their geometry as planar or volumetric, planar imperfections being essentially two-dimensional rather than three-dimensional in shape. Further distinction is often made between surface and embedded imperfections. These classifications are relevant to the inspection methods that are applicable and the effect of the imperfection on structural performance. The appropriateness of an inspection method is more dependent on the type and location of an imperfection than on the nature of its origin.

Various types of common imperfections or flaws resulting from manufacture, fabrication, or service are defined in the following sections.

Manufacturing imperfections

As indicated above, all structural materials contain imperfections. Imperfections that are typically found in rolled steel products such as plates or structural shapes are defined below.

Cracks. Cracks are planar discontinuities and can have one or more edges exposed to the surface or be completely embedded. In the manufacturing process, cracks result from thermo-mechanical induced stresses.

Inclusions. Inclusions are entrapped foreign materials and are generally volumetric. Most inclusions are a result of the formation of oxides and sulfides after the steel solidifies.

Laminations. Laminations are planar imperfections, generally an embedded discontinuity parallel to the surface of rolled products. Laminations commonly result when other types of imperfections in an ingot are rolled flat during the manufacturing process.

Laps. Laps, sometimes referred to as or in conjunction with seams, are long planar discontinuities usually exposed to the surface.

Pits. Pits are surface imperfections, essentially a cavity open to the surface.

Porosity. Porosity is the result of gas entrapped in solidifying metal, typically from the release of dissolved gases during cooling of ingots. Pores are volumetric imperfections, generally spherical or elongated in shape. Porosity in ingots may be transformed into laminations in rolled products.

Weld and fabrication discontinuities

Fabrication processes can also introduce imperfections into steel structures. In particular, the welding process can produce a number of different types of discontinuities, many of which are similar to those introduced in manufacturing of steel. Gases may become entrapped in solidifying weld metal, resulting in porosity. Inclusions may occur in weld metal, most commonly from entrapped slag. (Tungsten inclusion may also occur from improper gas tungsten arc welding procedure.) Cracks can occur in weld metal, the heat affected zone, and base metal and are usually the result of high localized stresses. Other types of discontinuities that occur in weldments are defined below.

Delamination. Delamination is the separation of a lamination caused by stress perpendicular to the plane of the lamination.

Convexity or reinforcement. Reinforcement is the amount of weld metal in excess of the amount required to fill the joint, and convexity is the distance a fillet weld extends beyond a line joining the weld toes.

Incomplete fusion. Incomplete fusion is a discontinuity resulting from incomplete melting and coalescence in the weld. Incomplete fusion is often caused by improper joint design, preparation, or welding technique. Insufficient welding heat, lack of access to joint faces, or the presence of oxides can prevent complete fusion.

Incomplete penetration. Incomplete penetration is the failure of weld metal to penetrate the joint completely. Typical causes are insufficient welding heat or improper joint design.

Insufficient leg. Insufficient leg is an undersized fillet weld leg.

Insufficient throat. Insufficient throat is a depression of the weld face of a fillet weld, resulting in a throat dimension less than the specified for a given weld size.

Lamellar tears. Lamellar tears are planar discontinuities parallel to the rolled surface. They are typically caused by high welding stresses in the through thickness direction and the presence of coplanar inclusions in the base metal.

Overlap. Overlap is the protrusion of weld metal beyond the weld toe or root and typically results from lack of control of the welding process, improper welding materials, or improper preparation of the base metal.

Undercut. Undercut is a groove or notch melted in the base metal at the weld toe or root and not filled with weld metal. Usually undercut is the result of improper welding techniques and/or excessive welding current.

Underfill. Underfill is a depression in the weld face or root extending below the adjacent surface of the base metal. It is the result of insufficient weld metal being deposited to fill the weld joint.

Weld imperfections are illustrated and discussed in greater detail in ANSI/AWS B1.10 (American Welding Society (AWS) 1986). ETL 1110-2-346 also contains an illustration of some common weld imperfections (U.S. Army Corps of Engineers (USACE) 1993b). Acceptance criteria for tolerable weld imperfections are given in AWS D1.1 (AWS 1996).

In addition to weld-related imperfections, other fabrication processes can introduce imperfections into a structure. These include small notches or cracks in a flame-cut edge, grinding marks, and mechanical gouges, all of which can serve as fatigue crack or fracture initiation sites.

Service-related imperfections

Normal operation and service can lead to the development of imperfections and can contribute to the deterioration of a structural system. Extreme or unintended loads can result in structural damage such as buckling or general yielding of members. In addition, cyclic loading, corrosion, and wear can lead to the development of cracks, pits, or other types of imperfections. Buckling, yielding, and deformation of structural members are outside the scope of this report. Inspection for this type of damage is discussed in ETL 1110-2-351 (USACE 1994).

Cyclic loading can cause initiation and propagation of fatigue cracks, which if not detected and repaired, can lead to failure. Under certain conditions, cracks can also form due to stress corrosion cracking.

The general topics of corrosion damage and wear are not addressed in this report. (Inspection for corrosion damage is discussed in ETL 1110-2-351.) However, wear can result in small surface imperfections, and corrosion can cause the formation of pits or notches that serve as crack initiation sites.

The number and size of imperfections are not constant and will increase with time for an in-service structure. The obvious implication is that inspections must be performed periodically.

3 Nondestructive Test Methods

Nondestructive test (NDT) methods are essential for detecting flaws in structural components. Several methods are commonly used for flaw or crack detection in steel structures. The appropriateness of a particular method or methods for flaw detection in a given situation depends primarily on the type and nature of the defect and the geometry of the component and the type and circumstance of inspection. Other factors, such as cost and availability, will also be a consideration. Periodic inspection of steel hydraulic structures will rely heavily on visual and dye penetrant inspection. Brief descriptions of commonly used NDT methods are provided in the following section.

Visual Inspection

Visual inspection or visual testing is the most common and least expensive method for detecting surface flaws in steel components. Visual inspection is the first type of inspection to be performed in any quality control procedure or periodic inspection. It is usually performed either with the unaided eye or with the use of optical magnifiers. Although relatively simple, the effectiveness of a visual inspection is highly dependent on the skill of the inspector.

Equipment and materials

The equipment required for a visual inspection consists primarily of tools for cleaning, such as wire brushes and scrapers, and tools for aiding vision, such as flashlights and magnifying glasses. Magnifying glasses should be of 5X magnification or higher. Inspection mirrors and boroscopes are often used for inspection of inaccessible areas. Measuring scales are needed to determine the size of flaws.

Procedure

A visual inspection of an area usually begins with a preliminary examination of the surface before removing any dirt, rust, or protective coatings. The objective at this point is to observe any rust stains or cracks in the paint, as these can indicate problems in the underlying metal. Following this preliminary examination, all surface debris and protective coatings must be removed in the area to be inspected. Either hand cleaning or sandblasting is typically used, although the hand cleaning can be extremely time-consuming if it is necessary to remove paint or heavy rust.

Effectiveness

The effectiveness of a visual inspection is dependent on the experience and competence of the inspector. Under good conditions with sufficient illumination, cracks on the order of 0.25 in. (6.4 mm) long and 0.01 in. (0.25 mm) in width can be detected with the unaided eye in most steels except for rough castings and some welds (Committee 1982). The use of a magnifier will permit detection of cracks of roughly half this size. The principal limitations of visual inspection are the inability to detect subsurface flaws or the depth of surface cracks and very low probability of detection for small flaws.

The time required for the actual inspection will average approximately 0.8 ft² (0.075 m²) per minute; however, when a significant portion of the surface must be examined with a magnifier, the rate will be reduced (Committee 1982).

Liquid Penetrant Inspection

Liquid penetrant testing can be used to detect, define, and verify surface flaws in steel members or components. (It can also be applied to other nonporous materials.) Liquid penetrant testing is a relatively simple and inexpensive process that does not require any elaborate equipment and is capable of indicating virtually all types of cracks, porosity, laminations, or discontinuities exposed to the surface. This includes very small defects not visible to the unaided eye. For structural inspections, liquid penetrant inspection is commonly used to verify cracks or for detailed inspection in small areas.

In general, liquid penetrant testing consists of the application of a liquid penetrant that is absorbed into small surface defects or cracks by capillary action. The excess penetrant remaining on the surface is then removed. Usually this is followed by the application of a developer, commonly a fine powder. The developer acts as a blotter causing the penetrant to seep out of the flaws or cracks and onto the surface, providing a visual indication. Indication of a flaw with liquid penetrant is schematically illustrated in Figure 5.

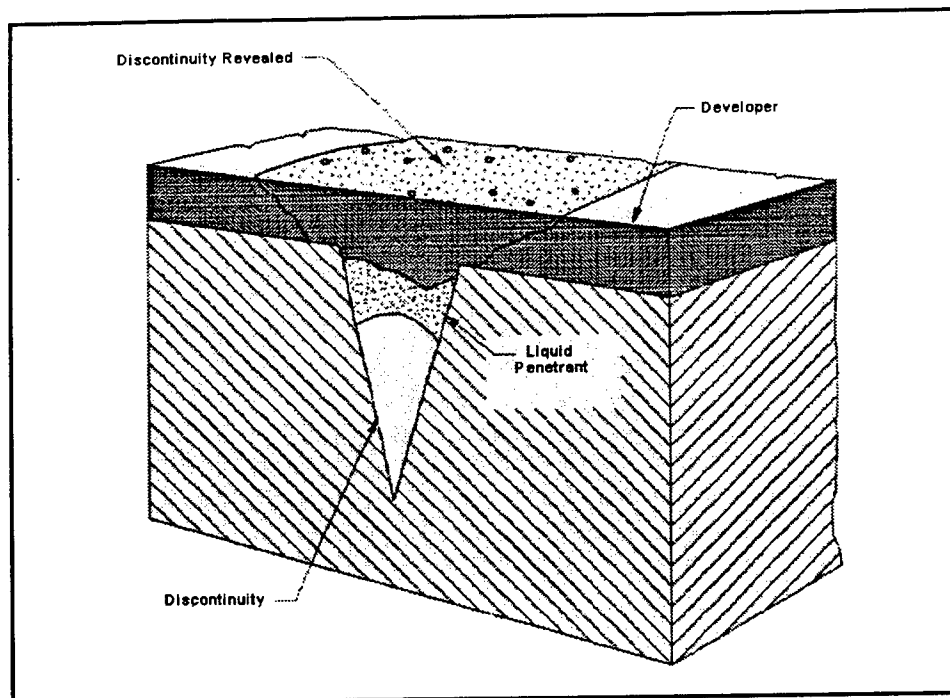

Figure 5. Flaw detection of a surface flaw with liquid penetrant (after ASM (1989))

Equipment and materials

Liquid penetrant materials (penetrants, emulsifiers, solvents, and developers) are produced and sold by manufacturers as a system and are commonly packaged in aerosol cans for ease of application. All materials used for an inspection must be from the same manufacturer and from the same group within the manufacturers products to ensure compatibility.

There are two basic types of liquid penetrants: fluorescent and visible dye. Fluorescent penetrants require the use of an ultraviolet light, which causes the penetrant to emit visible light. With visible dye penetrants, flaw indications are visible under ordinary white light. Because of the wide variety of applications for liquid penetrant testing, both types of penetrants (fluorescent and visible dye) have been developed for use in three different systems: water-washable, post-emulsifiable, and solvent-removable. The difference in these systems is the manner in which excess penetrant is removed from the surface prior to the application of the developer. Water-washable penetrant can be removed with water. A post-emulsifiable system is used to detect minute flaws and employs high sensitivity penetrant that is not water washable and requires the application of an emulsifier that makes the penetrant soluble in water, allowing for removal of excess penetrant by water rinsing. Solvent-removable systems require the use of a solvent to remove excess penetrant. The selection of the appropriate system is dependent on the surface conditions, characteristics of the defects expected, time and place of inspection, required sensitivity, and size of the component being inspected. Generally, fluorescent penetrants are more sensitive than liquid dye but require an ultraviolet light.

Water-washable and post-emulsifiable require a source of water and are usually used for small parts. For field inspection of structures, solvent removable visible dye is most often used. Recommendations for selecting the appropriate type and system of liquid penetrant can be obtained from the manufacturer or in reference (American Society for Metals (ASM) 1989).

Procedure

Liquid penetrant inspection, irrespective of the type or system used, requires the following five general operations.

- a. *Surface preparation.* Thorough cleaning of the surface to be inspected is required. This includes removal of paint or other coatings. Before application of penetrant, the surface must be clean and dry, and discontinuities exposed to the surface should be free of contaminants.
- b. *Application of penetrant.* After cleaning, liquid penetrant is uniformly applied to the surface. The penetrant should form a uniform film over the surface and should be allowed to remain a sufficient amount of time to penetrate into any surface discontinuities. The length of time required for penetration depends on the type of penetrant and discontinuity. Manufacturer's recommendations should be followed.
- c. *Removal of excess penetrant.* Excess penetrant must be removed from the surface. The object of this step is to uniformly remove excess penetrant from the surface without removing penetrant from the discontinuities. The procedure for this step depends on the penetrant system used (water-washable, post-emulsifiable, or solvent-removable). Some penetrants may be removed simply by wiping. In any case, the manufacturer's recommendations should be followed.
- d. *Application of developer.* A thin layer of developer is applied after the excess penetrant has been removed. The developer, usually a fine powder, acts as a blotter that absorbs penetrant from the discontinuities. The developer also provides a contrasting background to aid in inspection and should be uniformly applied.
- e. *Inspection.* The final step is visual examination. Surface flaws or discontinuities will be indicated by penetrant absorbed through the developer. Dye penetrants should be inspected under good (white) lighting, and fluorescent penetrant requires ultraviolet lighting to visually observe indications.

The effectiveness of liquid penetrant testing is dependent on the properties of the penetrant, emulsifier (if used), and developer. Liquid penetrant should provide uniform wetting of the surface of the test specimen or area and have the ability to migrate into flaws open to the surface. The primary factors affecting the ability of the penetrant to flow over the surface and enter into defects are cleanliness of the surface, size and configuration

of the cavity, and the surface tension and cohesiveness of the liquid. Emulsifiers, when required, are used to render penetrant water washable and function through diffusion or detergent action. In order to be effective, a developer should be applied in a thin uniform coating and must be absorptive with a fine-grain size in order to provide sharply defined indications of flaws. A developer should also provide a contrasting background for indications.

Effectiveness

Field inspection of hydraulic steel structures requires complete removal of paint or protective coatings in the area to be inspected. This will add to the time and cost of inspection. If paint is removed by grinding, the direction of grinding should be perpendicular to the expected crack orientation so as not to obscure fine cracks.

The application of penetrant from an aerosol can be accomplished at a rate of about 1 ft² (0.1 m²) in 5 sec. Penetration time varies from 5 to 30 min. Removal of excess penetrant requires about 1 min for a 1 ft² (0.1 m²) area for a water-washable system. Time required for application of developer is about the same as for application of penetrant; however, there may be some delay before visual indications are apparent.

For dye penetrants (as opposed to fluorescent), cracks on the order of 0.001-in. (0.025-mm) thickness should be detectable. Fluorescent penetrants may detect cracks of 0.0001 in. (0.0025 mm) in thickness. Liquid penetrant inspection is reported to be completely effective in indicating cracks of 0.35 in. (8.9 mm) or greater in length (Committee 1982). The absorption of penetrant by the developer will tend to magnify the size of flaws, particularly the width of cracks. Consequently, accurate dimensions of surface flaws cannot be determined from the penetrant indication.

Pertinent references for liquid penetrant inspection include ASTM E 165-94 (ASTM 1994b) and ASM Handbook Vol. 17 "Nondestructive Evaluation and Quality Control" (ASM 1989).

Magnetic Particle Inspection

Magnetic particle inspection is a method for detecting surface and shallow subsurface discontinuities in ferromagnetic materials. It is based on the principle that a magnetic field in a material containing a discontinuity will be locally disrupted in the vicinity of the discontinuity. The disruption in the magnetic field and, consequently, the presence of a discontinuity is indicated through the application of fine ferromagnetic particles applied over the surface of the component under inspection. As illustrated in Figure 6, these particles are attracted by the leakage of magnetic field at a discontinuity and are held in a pattern that generally indicates its size, shape, and location.

Magnetic particle inspection has many applications in industry including in-process inspection and quality control, final inspection, and maintenance inspections and has been adapted to a wide variety of manufactured products and structural components. The adaptability of magnetic particle inspection is derived, in part, from the various methods for producing magnetic fields in a component.

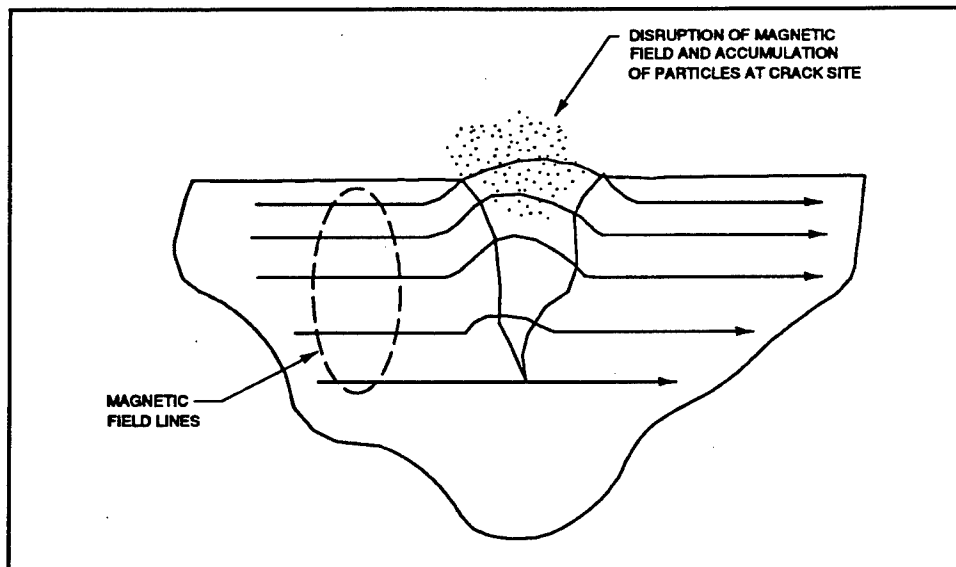

Figure 6. Magnetic particle indication at a surface discontinuity (after AWS (1986))

The principal advantage of magnetic particle over visible or dye penetrant testing is that subsurface discontinuities and cracks filled with foreign (nonmagnetic) material can be detected. However, the sensitivity to subsurface discontinuities is inversely related to the distance below the surface and is directly related to the size of the discontinuity. Limitations of the method include the need for large electrical current for inspection of large components, possibility of false indications from changes in magnetic characteristics at the edge of the heat-affected zone in weldments, reduction in sensitivity from paint or other nonmagnetic coverings, and, although not a problem for hydraulic steel structures, applicability to only ferromagnetic materials. Also, linear discontinuities, such as a crack, that are oriented parallel to the direction of the magnetic flux will not be detected. This is generally not a limitation because of flexibility in generating magnetic fields in different orientations.

Equipment and materials

Magnetic particle inspection requires that the component under inspection be properly magnetized so that leakage fields resulting from discontinuities attract magnetic particles. The basic equipment required consists of a power supply, means for generating or inducing a magnetic field in the component under inspection, and the magnetic particles required for

indications. In addition, adequate lighting is needed (ultraviolet light for fluorescent particles), and tools for cleaning are required.

Both direct current and alternating current power supplies are used in magnetic particle inspection. If the magnetic field is generated by current flow through the component being inspected, direct current will provide greater sensitivity to subsurface discontinuities compared with alternating current, which tends to flow near the surface.

The various types of equipment are generally categorized by the method of generating a magnetic field. For field inspection of large welded structural components, prod contacts and yokes are the most suitable means of generating the magnetic fields. For other applications such as machine parts, castings, forgings, annular or tubular products, and the flow of electric current through coils or linear conductors, induced current or direct electrical contact can be used to generate a magnetic field. The use of coils, central conductors, direct contact, or induced current methods are described in reference ASM (1989).

Electromagnetic yokes consist of a coil wound around a U-shaped core having either fixed or adjustable legs. Current flow in the coil creates a magnetic field in the core. As shown in Figure 7, the component being inspected completes the path of the magnetic flux. Permanent magnet yokes may also be used but are less common.

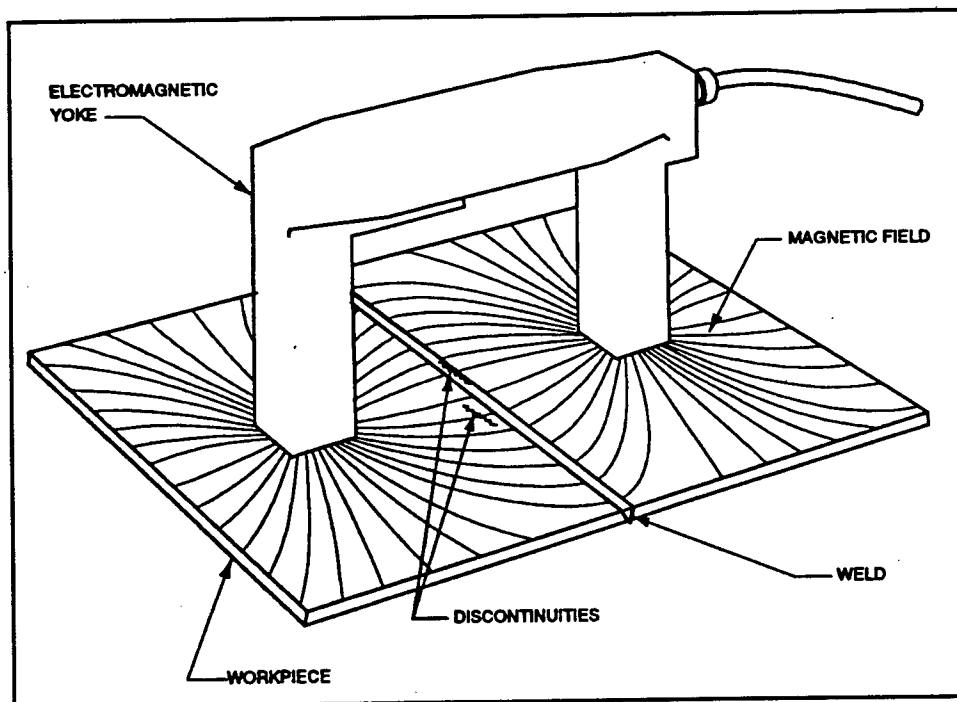

Figure 7. Electromagnetic yoke shown with magnetic field (after ASM (1989))

Prod contacts are typically used for the inspection of large components. As shown in Figure 8, a generally circular magnetic field is generated

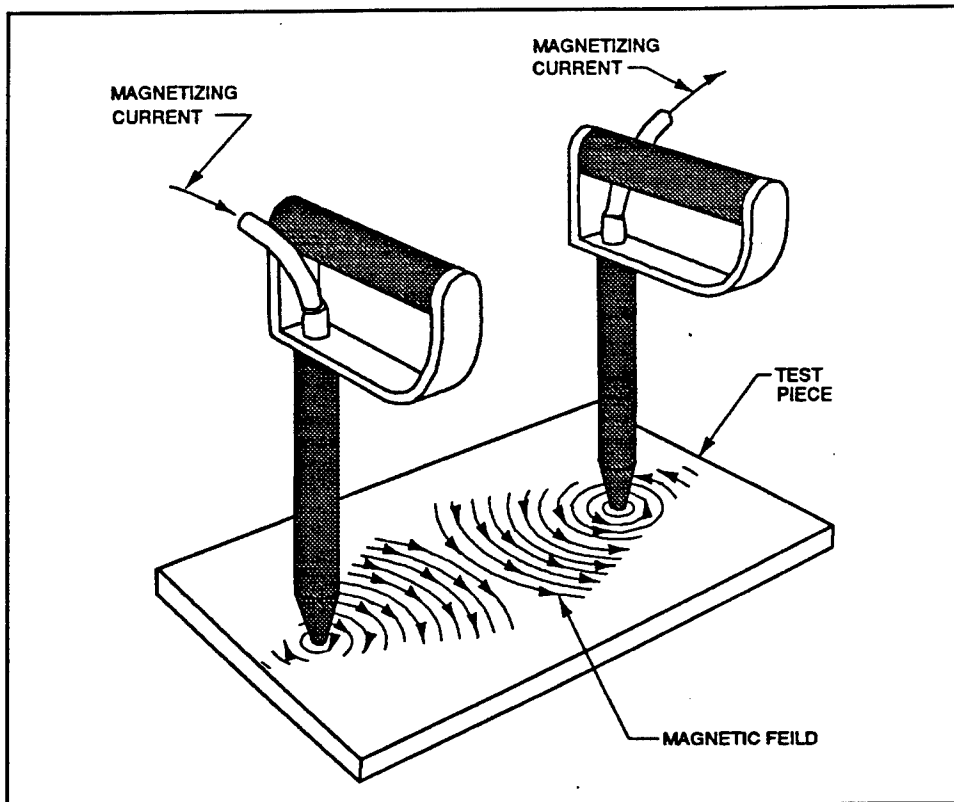

Figure 8. Prod contacts shown with magnetic field (after ASM (1989))

around each prod by current flowing through the prods and the work piece. The prods are usually placed 12 in. (300 mm) or less apart and readily relocated to allow for inspection of large areas or weldments and for reorienting the magnetic field. Prod contacts are well suited for field inspection because of portability and result in greater sensitivity to subsurface discontinuities.

Magnetic particles are classified as either dry particle or wet particle according to the method in which they are applied to the component being inspected. Dry particles are more sensitive for use on rough surfaces and for detecting flaws below the surface. They are generally used with portable equipment. Wet particles have greater ability to indicate fine discontinuities and are usually used with stationary equipment. Both types of particles are available with pigmented or fluorescent colorings for greater visibility. An ultraviolet light is required for fluorescent particles.

In dry particle inspection, the particles are applied in a uniform cloud and are attracted by the leakage field while suspended in air, allowing for free movement of the particles. Dry particles can be applied by rubber spray bulbs or specially designed mechanical blowers. (Application by direct contact or by pouring particles onto the surface is not recommended because it inhibits mobility of the particles.)

Wet particles are suspended in oil or water with conditioners to maintain adequate dispersion and mobility of the particles in the liquid. Oils employed are light, low-viscosity petroleum distillates. Water provides a

more cost-effective medium compared with oil and generally includes added rust inhibitors, wetting agents, and antifoam agents.

Procedure

In general, magnetic particle inspection includes the following steps.

- a. *Determine required equipment.* The size and shape of the component as well as the type of discontinuities expected need to be established in order to determine the method of magnetization, type and magnitude of current, and type of magnetic particles. Typically, prod contacts or yokes with the dry particle method will be most suited for inspection of welded hydraulic steel structures. Dry particles are better suited for field inspection.
- b. *Surface preparation.* The surface must be free from dirt, grease, oil, water, and other contaminants that may inhibit the movement of particles. Rough paint surfaces or other coatings may also interfere with the movement of particles and should be removed.
- c. *Magnetization and application of particles.* The magnetic field must be generated in the component, perpendicular to the orientation of any expected discontinuities, followed by the application of magnetic particles. If required, this process is repeated for different orientations of the magnetic field.
- d. *Cleaning and demagnetizing.* If the magnetic particles or residual magnetic field interferes with operation or maintenance, cleaning and demagnetizing must be performed. This is generally not required for hydraulic steel structures.

Effectiveness

Sensitivity for magnetic particle testing is comparable with liquid penetrant. Under laboratory conditions, it has been reported that all cracks greater than 0.25 in. (6.4 mm) are detected (Committee 1982). Field conditions may significantly affect the probability of detection.

Radiographic Inspection

Radiographic inspection is based on differential absorption of penetrating radiation. In conventional radiographic inspection, an object is subjected to X-rays or gamma rays, and the radiation that is not absorbed by the test object exposes a film or photosensitive paper. Variations in thickness, density, or material composition of an object affect the intensity of radiation passing through the object. The variations in intensity of radiation are recorded as levels of gray on the film or paper. Evaluation of a radiograph is based on a comparison with known physical characteristics of the object or with standards derived from radiographs of similar objects of acceptable quality.

Radiographic inspection is applicable to most solid materials with the exception of those with very low or very high density and is used to detect volumetric flaws or imperfections. In general, only imperfections that have an appreciable dimension in a direction parallel to the radiation beam can be detected. (Detection usually requires a 2-percent or greater difference in absorption of radiation compared with the surrounding material.) Voids and inclusions are most readily detected, providing their dimensions are not too small relative to the thickness of the component.

The component being inspected is inserted between the source of radiation and the film or paper. This requires access to both sides of the component. The radiographic image is a function of the orientation of the work piece with respect to the radiation source and recording medium because of distortions inherent in shadow formulation. As shown in Figure 9, planar discontinuities such as cracks are more difficult to detect and may not be detected if not oriented parallel to the radiation beam. Tight cracks in thick sections typically cannot be detected even if advantageously oriented. Radiographic inspection is more suited for indicating weld shrinkage

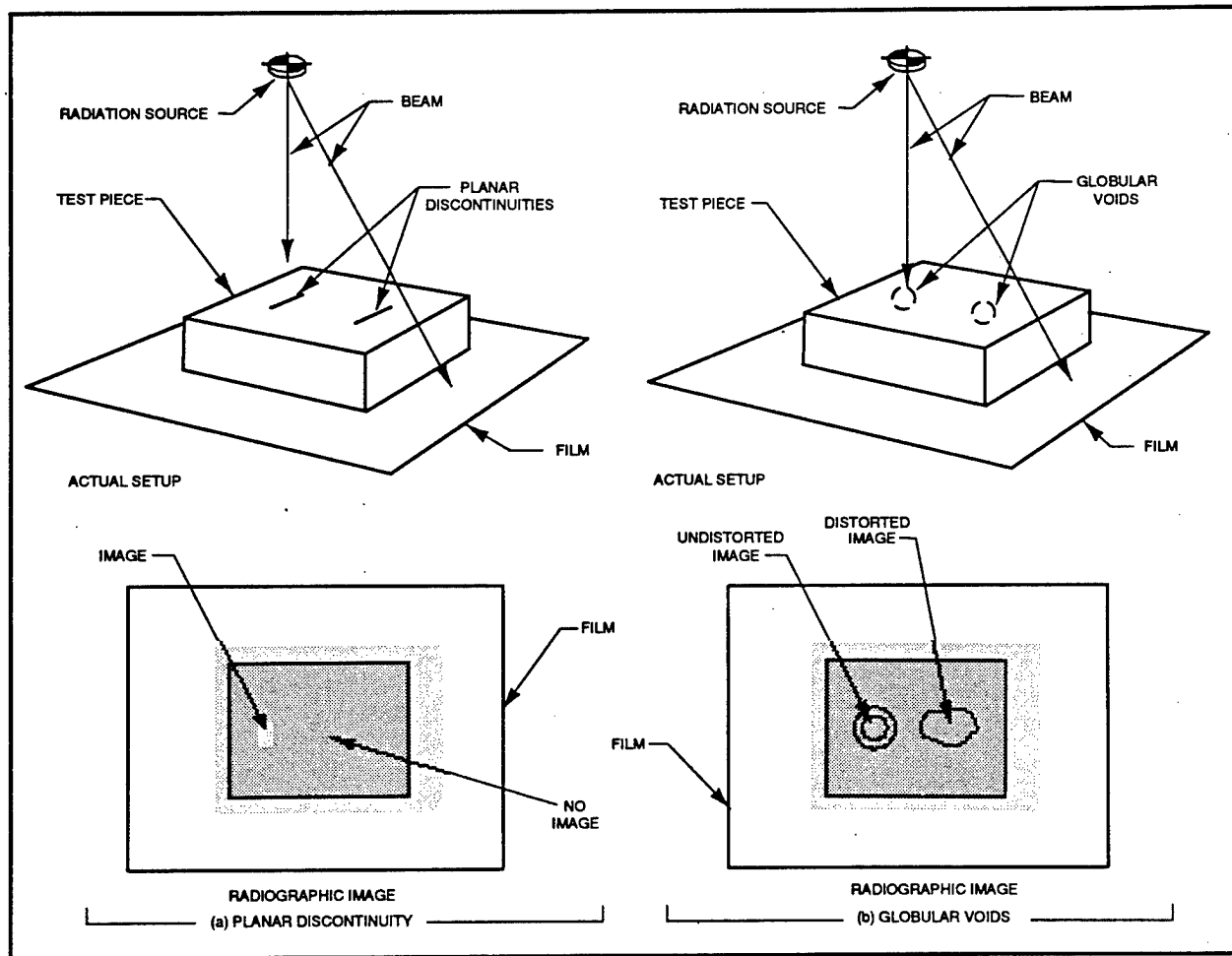

Figure 9. Effect of direction of radiation on indications of discontinuities (after ASM (1989))

cracks since they tend to be open, whereas fatigue cracks are often closed and are not easily detected.

Radiography is typically used on weldments and castings where there is a critical need to prevent components with internal discontinuities from being put into service. Although not limited to detection of internal flaws, radiographic and ultrasonic inspection are the most commonly used methods for detecting flaws well below the surface. Radiographic inspection is better suited for volumetric or nonplanar flaws. Compared with other methods, radiographic inspection is expensive. Significant capital and operating costs are involved. Film is appreciably costly and is required in quantities in direct proportion to the size of the area being inspected. Obtaining and interpreting radiographs require highly trained personnel. In addition, safety requirements impose additional economic and operational restrictions.

Materials and equipment

A basic radiographic inspection system consists of a source of radiation and a recording medium, usually film or paper. Radiography may also be performed in real time where an image is viewed directly on a viewing screen or monitor. Additional equipment includes film holders and filter screens. Several factors can affect the quality of a radiograph. Consequently, image quality indicators, alternatively referred to as penetrameters, are used. These are thin pieces of material with similar radiation absorption characteristics as the material being examined. Image quality indicators usually have a lead identification number and three holes of differing diameters drilled through the thickness. When placed on the test piece, the image quality indicator provides a means to measure the contrast and, to some extent, the resolution of the radiograph. Additional equipment includes movable shielding, usually lead, and exposure monitoring devices such as dosimeters and film badges. Obviously, facilities for processing the radiographic film are also required.

Procedure

Radiographic inspection for flaws, although relatively simple in its basic concept, is a complex technology involving a large number of variables. Highly trained personnel are required to produce and interpret a radiograph. Consequently, radiographic inspection services are usually obtained from a specialized contractor. The basic procedure includes the following steps.

- a. *Selection of radiation source and film.* This initial step requires consideration of the thickness, geometry, and absorption characteristics of the material.
- b. *Selection of view.* The view selected for a radiograph is a major factor in the ability to detect certain types of flaws. (See Figure 9.) This requires some knowledge of the expected type of flaws and their orientation.

- c. *Making the exposure.* This step includes positioning the radiation source, film, filters, test piece, image quality indicator, and identification markers. Factors to be considered are thickness, film speed, and radiation intensity.
- d. *Film processing.* This is an important part of the radiographic procedure. Inadequate processing can be as detrimental as poor exposure practice. Either manual or automatic processing may be used.
- e. *Interpretation.* This includes determining the quality of the radiograph as well as the nature and extent of any discontinuities. Inspection results should be accurately and clearly reported.

Effectiveness

Radiographic inspection is an effective method of flaw detection, particularly in critical applications where it is necessary to ensure that defects do not exist in a component before it is placed in service. The effectiveness of radiographic inspection is primarily limited to volumetric defects with dimensions greater than 1 percent of the component's thickness.

Ultrasonic Inspection

Ultrasonic inspection is a widely used nondestructive inspection method having the capability to detect surface and subsurface flaws. It also can be used to measure thickness of material and has less commonly used applications in determining physical properties such as modulus of elasticity, bond characteristics in joined materials, and metallurgical properties such as structure and inclusions. Ultrasonic inspection is used for quality control and in-service inspection in a wide range of applications in many industries including electronic component manufacturing, metals production, and the fabrication/manufacture and maintenance of structures and machinery.

Ultrasonic inspection is based on transmission and reflection of acoustic energy. Beams of high-frequency, typically 1 to 5 MHz, sound waves are introduced into the component being inspected and are reflected at material interfaces. Analysis of the reflected waves permits detection and characterization of flaws. The degree of reflectivity at an interface depends primarily on the physical state (solid, liquid, or gas) and to a lesser degree on the physical properties of the material on the opposite side of the interface. Near complete reflection occurs at metal-gas interfaces, while metal-liquid or metal-liquid interfaces provide partial reflection. Consequently, cracks, laminations, shrinkage cavities, porosity, or other discontinuities that provide metal-gas interfaces are easily detected. Inclusions or other discontinuities are detected by partial reflection or scattering of the ultrasonic waves. Flaws are indicated on an oscilloscope or a hard copy device and can be characterized through calibration of the test equipment with reference pieces containing discontinuities of a known size and shape.

The principal advantages of ultrasonic inspection include the capability to detect flaws well below the surface (up to several feet), high sensitivity to small flaws, and greater accuracy compared with other methods in determining size, shape, orientation, and nature of a discontinuity. In addition, only one side of a member or component need be accessible; indications are immediately observable; and unlike radiographic testing, ultrasonic waves do not present health hazards. However, extensive technical knowledge is required to develop test procedures for ultrasonic inspection, and experienced personnel are required to conduct tests and interpret results.

The most common method of ultrasonic inspection used in flaw detection is the pulse-echo method. In pulse-echo inspection, short bursts or pulses of ultrasonic energy are introduced into the test piece at regular intervals of time. If the waves encounter a reflecting surface, some or all of the energy is reflected depending on the size of the surface and the material on the opposite side of the interface. The direction of the reflected waves is affected by the orientation of the reflecting surface. The reflected ultrasonic waves are monitored for both the amount of energy reflected in a particular direction and the time between transmission of the wave pulse and reception of the echo.

Two other ultrasonic methods are used for flaw detection. The attenuation method is based on measuring only the attenuation of the ultrasonic waves and has the disadvantage that flaw depth cannot be measured. The attenuation method is primarily used for inspection of plates for cracks or laminations of relatively large dimension. The frequency-modulation (FM) method is similar to the pulse-echo method except that each burst of ultrasonic energy consists of waves whose frequency increases linearly with time. The advantage of the FM method is that it has greater resolution than the pulse-echo method.

Ultrasonic inspection may also be classified according to the method used to couple the ultrasonic transducer to the test piece. In the contact method, the transducer is in contact with the test piece via a couplant. Immersion methods are also used where both the test piece and the transducer are immersed in liquid. Immersion methods are faster and can provide improved accuracy in determining orientation of flaws, but are limited to use on relatively small parts that can be immersed in a tank. Wheel-type search units, essentially a transducer mounted in a fluid-filled wheel that is rolled across the test piece, are also available.

Equipment and materials

The basic elements of equipment required for ultrasonic inspection include a power supply, an electronic signal generator or pulser circuit, a search unit, couplants, a receiver-amplifier, and oscilloscope and an electronic clock. These elements are illustrated in the block diagram in Figure 10. Power supplies may be based on conventional alternating current or batteries for portable inspection equipment. The pulser circuit is used to generate a pulse of voltage analogous to the desired ultrasonic pulse. This voltage pulse is applied to the search unit, which essentially consists of a transmitting and receiving transducer. Search units can

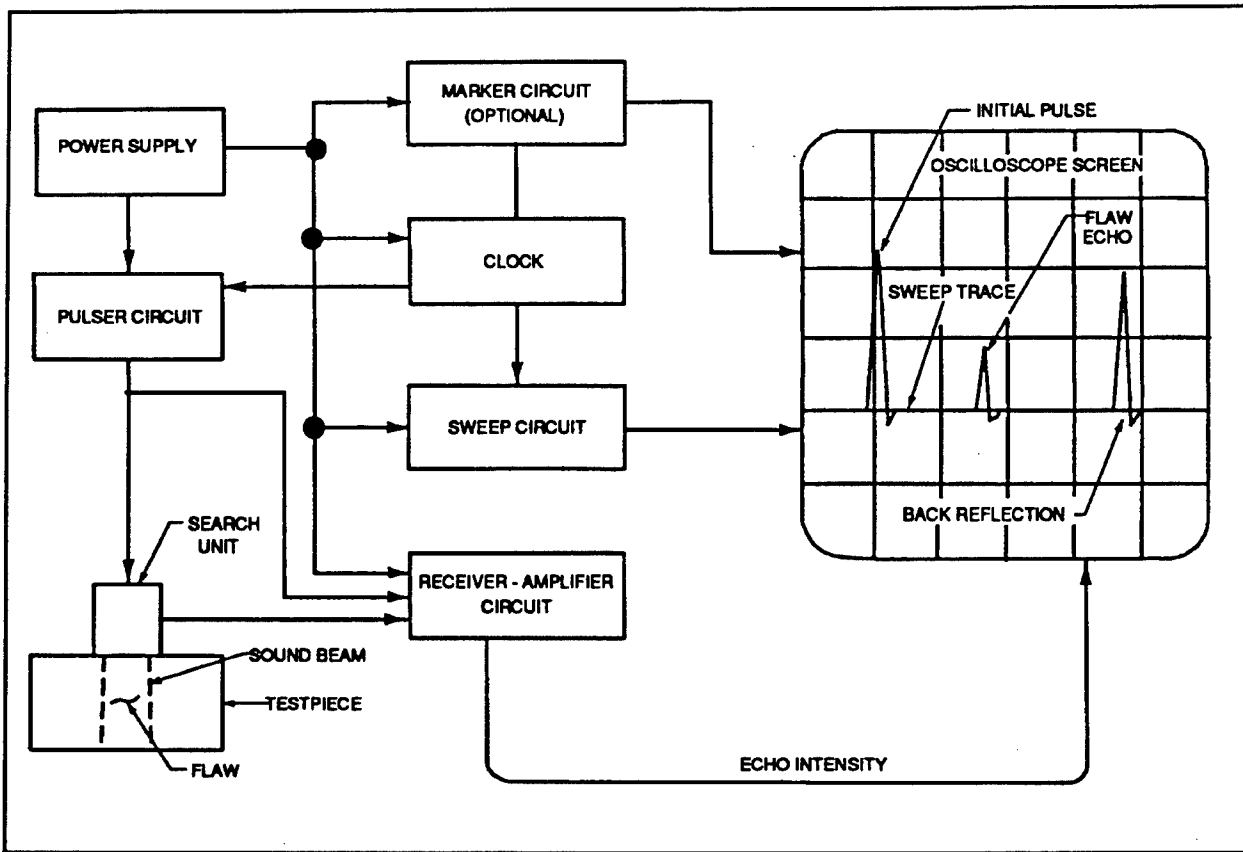

Figure 10. Block diagram of a pulse echo ultrasonic inspection system (after ASM (1989))

consist of physically separate transmitting and receiving transducers; or a single transducer can serve both functions; or both transducers may be housed in the same unit. The transducers are also characterized as straight-beam, where the ultrasonic beam is transmitted perpendicular to the surface, or angle-beam, where the beam is transmitted at a fixed angle in relation to the surface, allowing inspection of areas that would be inaccessible with straight-beam transducers. Because air is a poor transmitter of sound at the frequencies used for ultrasonic testing, a couplant is needed to couple the transducer(s) to the test piece, thus eliminating any air gap. In direct contact methods, silicon or petroleum grease, glycerin, or oils are used as couplants. Water is used as a couplant for immersion methods. The receiver-amplifier amplifies the signal from the receiving transducer and modifies the signal into a form suitable for display on the oscilloscope. The electronic clock is used as a timing reference for the entire system. In addition to these basic elements, additional features often are incorporated into ultrasonic test instruments. These include electronics for signal compensation or for automatic interpretation of the reflected signal. Also, reference blocks are required for calibration.

Procedure

For field inspection of structural components, the contact method of ultrasonic testing is typically used. It has advantages of being portable and flexible for adapting to different inspection requirements. The basic procedure for ultrasonic inspection includes the following steps.

- a. *Calibration.* The sensitivity of the equipment is adjusted to ensure detection of rejectable flaws. Test blocks are usually used, or the percentage of back reflection can be adjusted on the test piece.
- b. *Surface preparation.* The surface condition of the material being tested can affect sensitivity. The surface should be relatively smooth and clean. Tightly adhering paint may not have to be removed.
- c. *Examination.* For the contact method, either straight-beam or angle-beam transducers may be used. For weld inspection, angle-beam transducers are usually used because the transducer does not have to be placed on the weld surface. Straight-beam transducers can be used for inspection of base metal or for welds that have been ground flush. As shown in Figure 11, a weld is

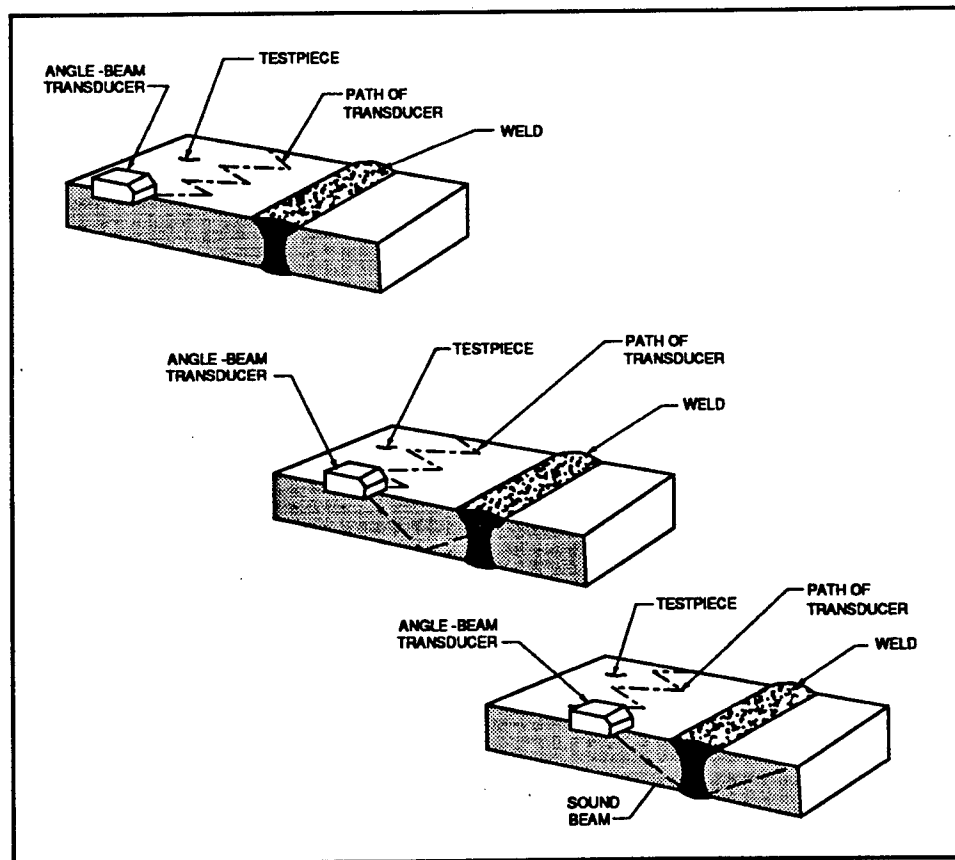

Figure 11. Scanning path of ultrasonic transducer for weld inspection (after ASM (1989))

scanned along its length by moving the transducer in a zig-zag pattern so that the sound waves travel through the weld.

- d. *Flaw characterization.* When a flaw is detected, a skilled operator can determine its size and shape by manipulating the transducer and observing the reflected signal on the oscilloscope.

Effectiveness

Ultrasonic inspection is widely used and effective. It can be used to detect flaws in a variety of different applications in both production quality control and in-service inspection. The minimum size defect that can be detected and the maximum depth at which defects can be detected depend on the equipment used, the surface condition of the material being tested, and the couplant used. Cracks 3/4 in. (18 mm) can be detected 3 to 10 ft (1 to 3 m) below the surface. The probability of detection for cracks in steel of 0.35 in. (9 mm) in length is extremely high with ultrasonic inspection.

Eddy Current Inspection

Eddy current inspection methods are based on electromagnetic induction and can be applied to magnetic and nonmagnetic metal components. In addition to the capability of detecting surface and in some cases subsurface discontinuities, eddy currents can be used to differentiate between a variety of physical, structural, and metallurgical properties including grain size, hardness, conductivity, and the thickness of nonconducting coatings or nonmagnetic plating on a magnetic metal.

Alternating current flow in a coil in proximity to an electrical conductor will induce current flow in the conductor. This current flow, or eddy current, creates a magnetic field that opposes the primary field created by the alternating current flow in the coil. The opposing magnetic field setup by the eddy currents creates an electrical loading on the coil. The presence of a surface or very near-surface discontinuity in the conductor will alter the magnetic field and can be sensed as a change in the electrical loading of the primary coil. Thus, discontinuities in an electrically conducting test piece can be detected.

Eddy current inspection has many advantages. It does not require direct contact with the test piece, and paint or coatings do not have to be removed. It is well suited to automated production line inspection. And, it is a versatile technique that can be applied to a number of inspection problems. The versatility of the method stems from the number of factors that can affect eddy currents. These include variations in geometry of the test piece and proximity to edges, electrical conductivity, and magnetic permeability. The sensitivity to these factors also limits the application of eddy current inspection techniques, primarily to production-line inspection of rod, pipe, and tubing products. In this application, the test pieces are prismatic and are well suited for passing through a coil, and variations in the eddy currents due to geometrical variations of the test piece are also

eliminated. Application of eddy current testing to field inspection of welded structural components typically found in hydraulic steel structures may be limited due to the complex geometry of the welded connections.

Equipment and materials

An eddy current inspection system consists of an electrical signal generator that supplies alternating current to an inspection coil, detection circuitry, and an output display device. Modulation of the inspection coil's electromagnetic field by variations or discontinuities in the test piece causes change in the amplitude and phase of the voltage across the inspection coil that is detected and analyzed by the detection circuitry. Some common types of inspection coils and their applications are schematically illustrated in Figure 12. The output signal from the detection circuit is fed to an output device, typically a meter, oscilloscope, or chart recorder.

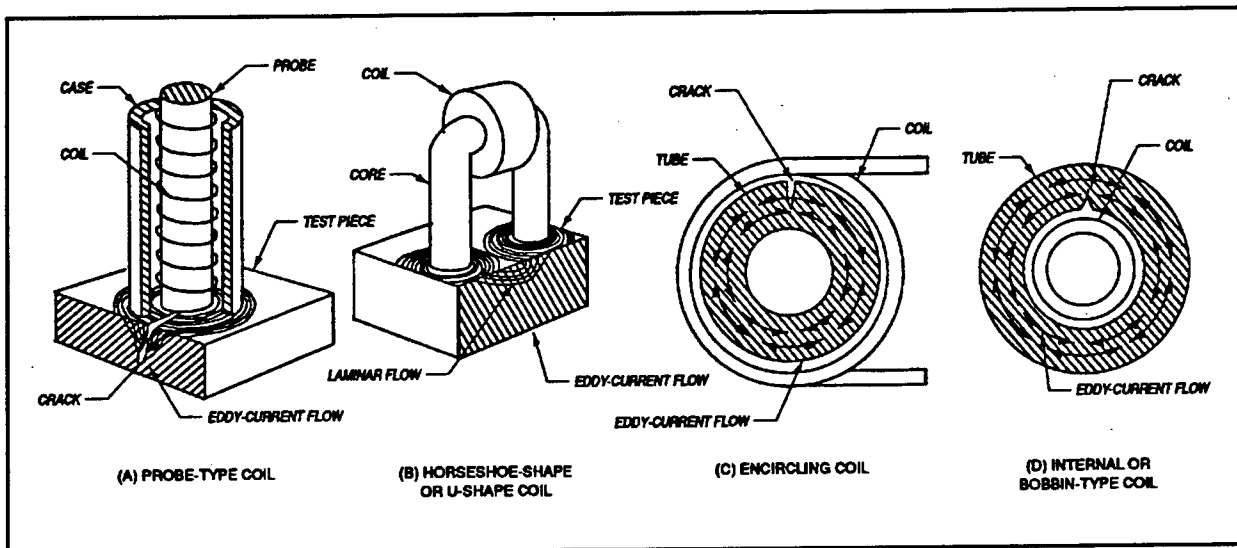

Figure 12. Common types of inspection coils (after ASM (1989))

Procedure

The procedure for eddy current inspection depends on the type of inspection. For surface or slightly subsurface flaw detection in fabricated steel structures, the basic elements of procedure for eddy current inspection include the following.

- a. *Selection of inspection equipment.* This includes selecting the type and appropriate electrical parameters for the probe inspection coil, the frequency of the signal supplied to the inspection coil, and the type of detection circuitry. These will depend on the geometry and electromagnetic properties of the test piece and the size and depth of flaws.

- b. *Adjust sensitivity.* The sensitivity of the eddy current inspection must be adjusted. Reference samples with known flaw sizes may be required.
- c. *Scanning.* The inspection probe is positioned along the test piece. Indications of discontinuities are observed on the display device.

Effectiveness

Any discontinuity that appreciably alters the normal flow of eddy currents can be detected. Surface discontinuities are most readily detectable. The sensitivity to discontinuities of a given size decreases with distance below the surface. Generally, discontinuities greater than 0.5 in. (12 mm) below the surface cannot be detected. For surface discontinuities, the sensitivity of eddy current inspection is comparable with that of dye penetrant.

Eddy current inspection has the advantage of being able to detect discontinuities through paint films. This can result in considerable savings of time and effort for inspection of in-service structures. However, many variables can affect the sensitivity of eddy current testing including local geometrical variations. While it is well suited for production inspection of prismatic components, eddy current testing is often not readily adapted to field inspection of complex weldments.

Acoustic Emission Inspection

A wide variety of structural materials, including concrete and metals, emit high-frequency stress waves when experiencing plastic deformation or crack growth. They are also produced in metals during phase transformations. These stress waves or acoustic emissions result from the rapid release of strain energy. Acoustic emission inspection is based on the monitoring and interpretation of acoustic emissions generated by a structure under load. It can provide information concerning the location and significance of flaws. Due to limitations, primarily noise, acoustic emission inspection has very limited application in field inspection of large structural systems and would not be generally applicable to inspection of steel hydraulic structures. However, the information in this section is provided as background information and is included for completeness.

Applications of acoustic emission inspection include continuous monitoring or proof testing of critical structures such as pressure vessels for nuclear applications, production monitoring of weldments during welding and cooling, and experimental research on fracture mechanisms and behavior of materials. Acoustic emission inspection has also been used for detecting stress-corrosion cracking.

A typical acoustic emission inspection system consists of a number of sensors, a preamplifier, signal filters, amplifier, electronic counter system, and a recording voltmeter. Audio and visual monitoring and recording

equipment are optional but useful in setting up and monitoring tests. Quantities that are directly measured typically include a summation of all acoustic emission counts or count rate as a function of load or time. In addition, audible or visual representation of the acoustic emission may be monitored through a loudspeaker or an oscilloscope.

Acoustic emission has certain advantages compared with other nondestructive test methods. Most acoustic emissions radiate from the location of the discontinuity, and a sensor placed anywhere on a structure can detect the emissions. By employing triangulation techniques, systems with multiple sensors at various locations on a structure can be used to locate the source of acoustic emissions. In contrast, most other nondestructive inspection methods require some prior knowledge of the expected location and orientation of a discontinuity. Acoustic emission inspection is also extremely sensitive compared with other methods, providing that the discontinuity or crack is locally unstable.

Acoustic emission inspection also has a number of disadvantages when compared with other nondestructive inspection techniques. Considerable technical knowledge is required to design, set up, conduct, and interpret results from an acoustic emission inspection. Accurate description of an acoustic emission signal is very difficult primarily because of background noise encountered during inspection. Typically, noise is introduced by the loading mechanism in a test and relative motion or vibration of the loading apparatus and movement at joints or supports. In addition, once a discontinuity is detected, it is often difficult to obtain much quantitative information; another form of nondestructive inspection is needed to determine its type, geometry, and orientation.

4 Inspection Strategies

The basic strategy for detection of flaws in steel structures consists of determining how and where to inspect. In evaluating existing structures, this is part of the preinspection assessment as outlined in ETL 1110-2-351. Selection of appropriate NDT methods is necessary to ensure successful detection of flaws. In addition, it is not economical or rational to conduct detailed inspection of the type necessary to detect flaws over a complete structure or even broad areas of a component. The identification of critical areas for inspection is an important consideration in planning an inspection strategy.

Selection of Appropriate Inspection Methods

Selecting appropriate inspection methods depends on a number of factors including the type of structure or component, type and size of flaws expected, site conditions, availability and cost of equipment, and personnel. Although many factors are involved in determining the appropriate NDT method for flaw detection under a given set of circumstances, some general guidelines exist. The process generally consists of identifying suitable methods and selecting among them by considerations of the inspection requirements and cost and effectiveness of the methods. Often a single method is not adequate, and a combination of methods may be required.

Six primary factors should be considered in selecting NDT methods for flaw detection:

- Objective of the inspection.
- Type of flaws to be detected.
- Size and orientation of flaw that is rejectable.
- Location of the flaws within the component.
- Size and shape of the component.
- Characteristics of the material.

For civil works structures, nondestructive testing is primarily a tool for determining acceptability of material or fabricated components or for

detection of flaws in service. The appropriate method is selected based on the above factors and economic criteria. Table 1 provides some general guidelines on the applicability of the various NDT methods. The content is adopted from Appendix A of AWS B1.10-86 (AWS 1986).

Table 1 Applicability of Various NDT Methods			
Equipment Requirements	Application	Advantages	Limitations
Visual			
Light source, magnifiers, rulers, calipers, micrometer	Surface flaws or discontinuities	Economical and expedient, limited training and equipment required	Limited to visible surface flaws
Liquid Penetrant			
Penetrant, developer, cleaner, and ultraviolet light source if fluorescent dye is used	Surface flaws or discontinuities	Economical and expedient, limited training and equipment required	Surface flaws only, area must be clean, paint film or scale may hide flaws
Magnetic Particle			
Prods, yokes, or coils for inducing a magnetic field in the component under test, magnetic particles	Surface and slightly subsurface flaws	Economical and expedient, large areas can be quickly inspected in some applications	Power source is required, area must be clean and relatively smooth
Eddy Current			
Test equipment for inducing and detecting magnetic fields in the component being tested	Surface and some subsurface discontinuities	Relatively inexpensive, portable systems available	Shallow depth of inspection, material variations can affect test
Ultrasonic			
Ultrasonic transducer, associated electronics, CRT display and/or hard copy device, calibration standard	Most types of discontinuities, thickness measurements	Portable equipment that is decreasing in costs, high depth penetration	Requires skilled operator, surface must be relatively smooth for effective coupling of transducer
Radiographic			
Radiation source, film, film holders, lead screens, radiation monitoring equipment	Volumetric discontinuities, reduced sensitivity to planar discontinuities	Depth of penetration, radiographic images aid in characterization of discontinuities	Expensive, health and safety precautions required, access to both sides of component required, requires skilled operator, delay between exposure and availability of results

Personnel Qualification

The success of nondestructive testing methods can be highly dependent on the competence of the personnel performing the test and the test procedures used. Personnel performing nondestructive testing should thoroughly understand the technology and principles of the test methods.

Personnel performing NDT other than visual inspection should be certified as competent. Traditionally, NDT personnel have been qualified and certified by their employer in accordance with American Society for Non-destructive Testing (ASNT) Recommended Practice No. SNT-TC-1A (ASNT 1992). SNT-TC-1A provides guidelines for certification and recommends that three levels of certification be established (Level I, II, and III, with Level III being the highest). The basic levels of qualification are generally defined as follows:

Level I: Level I personnel are qualified to perform specific calibrations, tests, and evaluations for acceptance or rejection according to written instructions and to record results.

Level II: Level II personnel are qualified to set up and calibrate equipment and to interpret and evaluate results with respect to applicable codes, standards, and specifications. They are also qualified to organize and report results of NDT.

Level III: Level III personnel are qualified to establish techniques and procedures; interpret codes, standards, and procedures; and designate the NDT methods, techniques, and procedures to be used.

Employer certification is valid only for the term of employment and is not portable. ASNT has a Level III certification program that provides portable certification to an individual. The ASNT certification program is intended to provide consistent, minimum level of competence for Level III personnel. It requires passing a comprehensive examination administered by ASNT. ASNT is also currently developing a central certification program that will provide consistent and portable certification for all three levels of qualification.

Personnel performing visual inspection of hydraulic steel structures should be an engineer or technician with the appropriate level of training and/or experience to competently perform the work. For inspection of welded structural steel fabrication, AWS provides qualification and certification as a certified welding inspector (CWI) in accordance with AWS QC1 (AWS 1988). Certification as a CWI is an acceptable basis but is not required for visual inspection of welded fabrication.

Identification of Critical Areas

One of the most important tasks in conducting an inspection, particularly an inspection of an in-service structure, is the identification of critical areas. The objective is to identify areas that are most likely to contain flaws and/or where flaws are most likely to have significant consequence. By identifying these critical areas, allocation of finite resources for inspection can be used most effectively.

For hydraulic steel structures, fracture critical members (FCMs) are defined as "members and their associated connections subjected to tensile stresses whose failure would be expected to result in collapse of the

structure. Because of the significant consequence of failure, FCMs should be considered as critical areas for inspection for flaws or discontinuities. FCMs may be identified by a structural analysis. In general, main framing members that are or that have components that are subjected to tensile stresses in a structure that does not have redundant load paths would be considered fracture critical. In addition, components required for operation of the structure, such as lifting connections on vertical lift gates or tainter gates, would be fracture critical.

Critical areas, particularly areas where fatigue cracks may initiate and propagate, can be identified by considering the nominal member stress and the severity of the stress concentration at a given detail. Since the fatigue category of a structural detail is a direct indication of the severity of the stress concentration at that detail, it can be used along with the member stress to identify areas where cracking may be expected. (Fatigue categories are defined in both Load and Resistance Factor Design and Allowable Stress Design Manual of Steel Construction (American Institute of Steel Construction (AISC) 1994; AISC 1989) and AWS Structural Welding Code - Steel (AWS 1996). Low fatigue strength details (fatigue category D, E, or E') in a highly stressed member should be identified as critical areas. Conversely, fatigue category A or B details are not probable locations for initiation of fatigue cracks. A method of identifying critical areas based on fatigue categories and stress levels is outlined in ETL 1110-2-351.

Other critical areas for welded structures include highly constrained thick plate weldments. A component fabricated from rigid (thick and short) elements may develop high residual stresses from welding. These residual stresses combined with lower material toughness that often occurs in thick plates are often a cause of cracking. Weld defects often occur at details where accessibility was limited during fabrication. Other areas where cracks may initiate include weld arc strikes and tack welds.

5 Evaluation of Flaws

When flaws are detected in a structure, they must be evaluated to determine if and when repairs are required. There are essentially two means of evaluating the effect of flaws on a structure: (a) by comparison with published acceptance criteria applicable to the particular structure and/or member or (b) by a fracture mechanics and fatigue crack propagation analysis. In-depth discussion of the evaluation of flaws is beyond the scope of this report. However, a brief discussion of acceptance criteria and fatigue and fracture analysis is given in the following sections.

Acceptance Criteria for Weld Discontinuities

For welded structural steel fabrication, acceptance criteria for weld flaws are published in the Structural Welding Code - Steel (AWS 1996). In addition to specific criteria for acceptable flaw sizes, general workmanship requirements pertaining to weld profiles are provided. The acceptance criteria for flaws are based on the type of structure. Dynamically loaded structures have more stringent acceptability requirements compared with statically loaded structures due to the potential for fatigue crack propagation to critical size. Tubular structures are considered sufficiently unique in their design and detailing that separate criteria are provided.

The acceptance criteria are also based on the method of inspection employed since the type of flaw detected is dependent on the method. The criteria for visual, dye penetrant, and magnetic particle testing pertain to cracks, porosity, and undercut. Radiographic testing acceptance criteria are based on the size of a discontinuity. Flaws detected by ultrasonic testing are evaluated on a decibel amplitude basis and the size of the flaw.

For new fabrication, acceptance criteria for welds other than those specified are permitted by AWS D1.1, provided they are suitably documented and approved by the engineer. These criteria may be based on an engineering analysis, experimental data, or an evaluation based on past experience. For inspection of existing structures, acceptance criteria may be developed based on the above criteria. In any case, alternative acceptance criteria should take into consideration the material, load effects, and the service environment.

Fracture and Fatigue Evaluation

Fracture mechanics provides a means of assessing the acceptability of flaws in a structure. The critical flaw size that would initiate fracture may be estimated, and, if it is subjected to cyclic loading, the rate of fatigue crack propagation can be estimated. This enables the engineer to determine if and when repairs need to be made. A discussion of fracture mechanics and fatigue crack propagation is provided in ETL 1110-2-346 and ETL 1110-2-351. More detailed information on fatigue and fracture mechanics can be found in any texts on the subject, such as (Barsom and Rolfe 1987).

A fracture analysis of a flaw requires detailed information on the nature of the flaw, the member material properties, the load effects in the member, and the environment in which the structure is expected to perform. The following should be considered during inspection and evaluation:

- a.* The size, orientation, and location of a flaw must be known as well as the geometry of the member and any connecting members in the vicinity of the flaw. The crack geometry should be accurately determined and documented during the inspection process.
- b.* The material fracture toughness must be established. An accurate determination of toughness will require testing of material removed from the member. Charpy V-notch testing is a common and inexpensive means of estimating material toughness. Alternatively, a conservative estimate of fracture toughness can be used to estimate the critical flaw size.
- c.* The member stress levels should be determined from a reasonably detailed analysis or measured since the critical flaw size is dependent on the stress level.
- d.* The minimum service temperature must be established. The fracture toughness for structural steels varies dramatically with temperature. Consequently, the tolerable flaw size will be highly dependent on the minimum service temperature.

For a fatigue crack propagation analysis, the primary factors that must be established are the stress range or equivalent stress range for variable amplitude loading and the material parameters related to Paris' law.

References

- American Institute of Steel Construction. (1994). "Load and resistance factor design manual of steel construction," 2nd ed., Chicago, IL.
- American Society for Metals. (1989). *ASM handbook, nondestructive evaluation and quality control, vol. 17*. Formerly, *Metals handbook, nondestructive testing and quality control, vol. 11*. 9th ed. (1976). American Society for Metals, Metals Park, Ohio.
- American Society for Nondestructive Testing. (1992). *Recommended practice SNT-TC-1A*. American Society for Nondestructive Testing, Columbus, OH.
- American Society for Testing and Materials. (1994a). "Standard terminology for nondestructive examinations," E 1316-94, Philadelphia, PA.
- _____. (1994b). "Liquid penetrant examination," E 165-94, Philadelphia, PA.
- American Welding Society. (1986). *Guide for the nondestructive inspection of welds*. ANSI/AWS B1.10-86, American Welding Society, Miami, FL.
- _____. (1988). *Standard for qualification and certification of welding inspectors*. AWS QC1-88, American Welding Society, Miami, FL.
- _____. (1996). *Structural welding code - steel*. ANSI/AWS D1.1-96, American Welding Society, Miami, FL.
- Barsom, J. M., and Rolfe, S. T. (1987). *Fracture and fatigue control in structures*. 2d ed., Prentice-Hall, Englewood Cliffs, NJ.
- Committee on Fatigue and Fracture Reliability of the Committee on Structural Safety and Reliability of the Structural Division. (1982). "Fatigue reliability: Quality assurance and maintainability," *Journal of the Structural Division* 108(ST1), 25-46.
- U.S. Army Corps of Engineers. (1993a). "Design of hydraulic steel structures," Engineer Manual 1110-2-2105, Washington, DC.

U.S. Army Corps of Engineers. (1993b). "Structural inspection and evaluation of existing welded lock gates," Engineer Technical Letter 1110-2-346, Washington, DC.

_____. (1994). "Structural inspection and evaluation of existing spillway gates," Engineer Technical Letter 1110-2-351, Washington, DC.

REPORT DOCUMENTATION PAGE

Form Approved
OMB No. 0704-0188

Public reporting burden for this collection of information is estimated to average 1 hour per response, including the time for reviewing instructions, searching existing data sources, gathering and maintaining the data needed, and completing and reviewing the collection of information. Send comments regarding this burden estimate or any other aspect of this collection of information, including suggestions for reducing this burden, to Washington Headquarters Services, Directorate for Information Operations and Reports, 1215 Jefferson Davis Highway, Suite 1204, Arlington, VA 22202-4302, and to the Office of Management and Budget, Paperwork Reduction Project (0704-0188), Washington, DC 20503.

1. AGENCY USE ONLY (Leave blank)		2. REPORT DATE February 1997	3. REPORT TYPE AND DATES COVERED Final report	
4. TITLE AND SUBTITLE Flaw Detection Practices for Steel Hydraulic Structures			5. FUNDING NUMBERS	
6. AUTHOR(S) Joseph A. Padula				
7. PERFORMING ORGANIZATION NAME(S) AND ADDRESS(ES) U.S. Army Engineer Waterways Experiment Station 3909 Halls Ferry Road Vicksburg, MS 39180-6199			8. PERFORMING ORGANIZATION REPORT NUMBER Technical Report ITL-97-1	
9. SPONSORING/MONITORING AGENCY NAME(S) AND ADDRESS(ES) U.S. Army Corps of Engineers Washington, DC 20314-1000			10. SPONSORING/MONITORING AGENCY REPORT NUMBER	
11. SUPPLEMENTARY NOTES Available from National Technical Information Service, 5285 Port Royal Road, Springfield, VA 22161.				
12a. DISTRIBUTION/AVAILABILITY STATEMENT Approved for public release; distribution is unlimited.			12b. DISTRIBUTION CODE	
13. ABSTRACT (Maximum 200 words) <p>An overview of nondestructive testing of hydraulic steel structures (HSS) is presented. The nature of commonly occurring imperfections are described for welded, riveted, and bolted HSS. For each of six basic nondestructive test (NDT) methods, an overview of the theory is provided along with a description of equipment and materials required. The basic procedure for each method is described as well as the its effectiveness in detecting imperfections. Basic guidelines and references are provided for selection of appropriate NDT methods for specific applications and for evaluation of flaws.</p>				
14. SUBJECT TERMS See reverse			15. NUMBER OF PAGES 43	
			16. PRICE CODE	
17. SECURITY CLASSIFICATION OF REPORT UNCLASSIFIED	18. SECURITY CLASSIFICATION OF THIS PAGE UNCLASSIFIED	19. SECURITY CLASSIFICATION OF ABSTRACT	20. LIMITATION OF ABSTRACT	

14. (Concluded).

Acoustic emission inspection
Eddy current inspection
Hydraulic steel structures
Inspection
Liquid penetrant inspection

Magnetic particle inspection
Nondestructive test(ing)
Radiographic inspection
Ultrasonic inspection
Visual inspection