

MDDC - 1106

UNITED STATES ATOMIC ENERGY COMMISSION

Handwritten: 10/1/46

ADJUSTABLE ELECTRODE ARRANGEMENT FOR A SPARK SOURCE MASS SPECTROGRAPH

by
Wilfrid Rall
A. E. Shaw

LIBRARY OF CONGRESS
SCIENCE & TECHNOLOGY PROJECT
TECHNICAL INFORMATION SECTION

Handwritten: Abstract

Handwritten: 7

Argonne National Laboratory

OCT 27 1946

19970310 112

This document consists of 2 + 1 pages
Date Manuscript: June 25, 1946
Date Declassified: July 7, 1947

Its issuance does not constitute authority
for declassification of classified copies
of the same or similar content and title
and by same authors.

Technical Information Division, Oak Ridge Directed Operations
AEC, Oak Ridge, Tenn., 10-11-48--1500-18785

Printed in U.S.A.
PRICE 5 CENTS

DISTRIBUTION STATEMENT A
Approved for public release
Distribution Unlimited

DTIC QUALITY INSURED

ADJUSTABLE ELECTRODE ARRANGEMENT FOR A SPARK SOURCE MASS SPECTROGRAPH

By

Wilfrid Rall and A. E. Shaw

The design of a convenient electrode mounting for a spark source mass spectrograph must satisfy several requirements. (1) The electrodes must be adjustable to permit compensation for wear. (2) Such adjustment must also keep the spark centered. (3) The spark must be easily observed by the operator. (4) The entire unit should be easily opened for sample changes and easily disassembled for cleaning. (5) The anode must be insulated from ground and the cathode for 30,000 volts, DC. (6) The electrodes must be insulated from each other for as much as 75,000 volts, RF. (7) The entire unit must be vacuum tight.

It is, therefore, not surprising that the design of such units has undergone considerable evolution. All designs have used sylphon bellows to permit adjustments, and a Pyrex glass envelope to provide external insulation and visibility. However, the arrangement of the electrodes, the mounting of the various parts, the method of disassembly and the vacuum seal varied. In this paper, the latest design is presented; it is a slight modification of that used on the Mattauch type spectrograph.

Figure 1 shows the source assembly. One electrode, mounted in the pin-vise, is usually the sample to be analyzed and consists of a wire or fine tube, about 0.030-inch OD, with a powdered sample packed in it. The other electrode is a disk 1/16-inch thick made of pure copper or tantalum or some other suitable metal with a 1/32-inch conical depression and a hole 0.020 inch in diameter and 1/32 inch long through the center. The side facing the wire electrode is tapered so that the spark actually takes place between the wire and the tapered wall of the hole. The ions are pulled through the hole and accelerated to the cathode by the accelerating voltage which is placed across the gap between the anode and cathode, usually between 1/8 and 1/4 inch. Centering of the hole in the disk electrode is achieved by adjustment of the entire anode disk with respect to the fixed mounting rods before assembly. Centering of the wire electrode is permitted by the sylphon bellows. The adjustment is made by means of three tilt screws at 120° centers against which the tilting unit is kept tight by three springs and the vacuum. Once the wire electrode is centered, wear can be compensated by simply feeding the electrode holder through the Wilson seal by means of the feed screw.

The spark is easily observed since it is surrounded only by the three anode mounting rods and the heavy-wall Pyrex glass envelope. A very convenient vacuum seal to the glass envelope is achieved by the use of pure gum rubber gaskets covered with a light coat of good vacuum grease. The glass tube and gaskets are compressed between the two brass disks by means of screws which fasten the disks to three insulated spacers. These spacers are carefully ground to equal length, so that when the screws are tight, the two disks are parallel and coaxial. The 3/8-inch Bakelite rods are turned out of flat Bakelite sheets; the dielectric strength of Bakelite rod was found insufficient to withstand 30,000 volts. The second set of insulators and glass tube is used to insulate the parts at the potential of the wire electrode

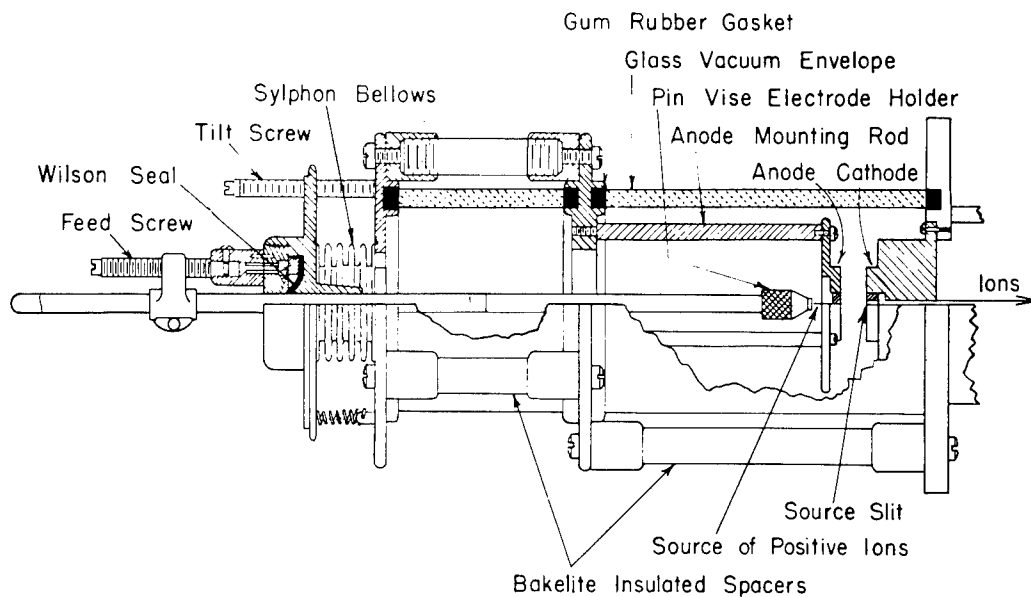

Figure 1. Adjustable electrode arrangement for a spark source mass spectrograph.

from the parts at the potential of the anode. This permits a positive mounting of the anode which is reproducible and insulated from the wire electrode and the cathode.

The gum rubber vacuum seals have been highly successful at our pressures of around 5×10^{-6} mm Hg. Their advantages for disassembly are obvious. The loosening of three screws (Phillips-head screws were used for convenience) is all that is needed to change an electrode or to gain access to parts for cleaning.