

**AEDC-TR-96-4**

# Strategic and Tactical Technology and Methodologies for Electro-Optical Sensor Testing

S. L. Steely, R. Dawbarn, H. S. Lowry, E. L. Kiech, and C. A. Doub  
Sverdrup Technology, Inc., AEDC Group

February 1997

Final Report for Period 1 October 1995 — 30 September 1996

Approved for public release; distribution is unlimited.

19970310 043

**ARNOLD ENGINEERING DEVELOPMENT CENTER  
ARNOLD AIR FORCE BASE, TENNESSEE  
AIR FORCE MATERIEL COMMAND  
UNITED STATES AIR FORCE**

**DTIC QUALITY INSPECTED 3**



## NOTICES

When U. S. Government drawings, specifications, or other data are used for any purpose other than a definitely related Government procurement operation, the Government thereby incurs no responsibility nor any obligation whatsoever, and the fact that the Government may have formulated, furnished, or in any way supplied the said drawings, specifications, or other data, is not to be regarded by implication or otherwise, or in any manner licensing the holder or any other person or corporation, or conveying any rights or permission to manufacture, use, or sell any patented invention that may in any way be related thereto.

Qualified users may obtain copies of this report from the Defense Technical Information Center.

References to named commercial products in this report are not to be considered in any sense as an endorsement of the product by the United States Air Force or the Government.

This report has been reviewed by the Office of Public Affairs (PA) and is releasable to the National Technical Information Service (NTIS). At NTIS, it will be available to the general public, including foreign nations.

## APPROVAL STATEMENT

This report has been reviewed and approved.



JERRY F. FAIRCHILD, Capt, USAF  
Technology Project Engineer  
Applied Technology Division  
Test Operations Directorate

Approved for publication:

FOR THE COMMANDER



ROBERT T. CROOK  
Asst. Chief, Applied Technology Division  
Test Operations Directorate

**REPORT DOCUMENTATION PAGE**

*Form Approved  
OMB No. 0704-0188*

Public reporting burden for this collection of information is estimated to average 1 hour per response, including the time for reviewing instructions, searching existing data sources, gathering and maintaining the data needed, and completing and reviewing the collection of information. Send comments regarding this burden estimate or any other aspect of this collection of information, including suggestions for reducing this burden, to Washington Headquarters Services, Directorate for Information Operations and Reports, 1215 Jefferson Davis Highway, Suite 1204, Arlington, VA 22202-4302, and to the Office of Management and Budget, Paperwork Reduction Project (0704-0188), Washington, DC 20503.

1. AGENCY USE ONLY (Leave blank)	2. REPORT DATE <b>February 1997</b>	3. REPORT TYPE AND DATES COVERED <b>Final Report for Period 1 Oct 1995 - 30 Sept 1996</b>
----------------------------------	--	--

4. TITLE AND SUBTITLE <b>Strategic and Tactical Technology and Methodologies for Electro-Optical Sensor Testing</b>	5. FUNDING NUMBERS <b>PE - 65807F PN - 0104</b>
--	--

6. AUTHOR(S) <b>Steely, S.L., Dawbarn, R., Lowry, H.S. III, Kiech, E.L., and Doub, C.A., Sverdrup Technology, Inc., AEDC Group</b>
---

7. PERFORMING ORGANIZATION NAME(S) AND ADDRESS(ES) <b>Arnold Engineering Development Center/DOT Air Force Materiel Command Arnold Air Force Base, TN 37389-9011</b>	8. PERFORMING ORGANIZATION (REPORT NUMBER) <b>AEDC-TR-96-4</b>
--	---

9. SPONSORING/MONITORING AGENCY NAME(S) AND ADDRESS(ES) <b>Arnold Engineering Development Center/DOT Air Force Materiel Command Arnold Air Force Base, TN 37389-9011</b>	10. SPONSORING/MONITORING AGENCY REPORT NUMBER
---	--

11. SUPPLEMENTARY NOTES <b>Available in Defense Technical Information Center (DTIC).</b>
---

12A. DISTRIBUTION/AVAILABILITY STATEMENT <b>Approved for public release; distribution is unlimited.</b>	12B. DISTRIBUTION CODE
--	------------------------

13. ABSTRACT (Maximum 200 words) <b>This report describes efforts to support technology developments for advanced sensor testing at Arnold Engineering Development Center (AEDC). Advanced sensor testing concepts and methodologies for AEDC test facilities are described in detail. Methodologies are provided to support generation of complex scenes for sensor testing with some emphasis devoted to fractal interpolation. Experimental evaluation and development efforts demonstrate the feasibility of extending the Direct Write Scene Generation (DWSG) method for optical projection through electro-optical sensor systems containing the sensor optics. The report provides a discussion of verification and validation concepts and methods to support advanced optical diagnostics and sensor testing.</b>
--

14. SUBJECT TERMS <b>sensors, test and evaluation, testing methodologies, closed-loop, real-time, surveillance, seeker, simulations, focal plane array, DWSG, laser testing, noise</b>	15. NUMBER OF PAGES <b>31</b>
	16. PRICE CODE

17. SECURITY CLASSIFICATION OF REPORT <b>UNCLASSIFIED</b>	18. SECURITY CLASSIFICATION OF THIS PAGE <b>UNCLASSIFIED</b>	19. SECURITY CLASSIFICATION OF ABSTRACT <b>UNCLASSIFIED</b>	20. LIMITATION OF ABSTRACT <b>SAME AS REPORT</b>
--	---	--	---

## PREFACE

The work reported herein was conducted by the Arnold Engineering Development Center (AEDC), Air Force Materiel Command (AFMC), under Program Element 65807F. The results were obtained by Sverdrup Technology, Inc., AEDC Group, aerodynamic and propulsion test contractor at AEDC, Arnold Air Force Base, TN 37389-4300 under AEDC Job Number 0104. The Air Force Project Manager was Capt. Frank Fairchild, AEDC/DOT. This report describes the work effort from October 1, 1995 through completion on September 30, 1996, and updates information regarding sensor testing methodologies and corresponding technologies developed during this period complementary to Job Numbers 0103 and 2656.

## ACKNOWLEDGMENTS

This document was prepared by Space Technology Team members at AEDC. Contributors and their phone numbers are listed below:

Ron Dawbarn	615-454-7348
CeCe Doub	615-454-5125
Earl Kiech	615-454-7669
Heard Lowry	615-454-3709
Sid Steely	615-454-7730

## CONTENTS

	<u>Page</u>
1.0 INTRODUCTION .....	5
1.1 Vision Drivers for Electro-Optical Sensors .....	5
1.2 Assessment of Existing Capabilities .....	5
1.3 Basis of Need .....	6
1.4 Needed Capability .....	6
1.5 Priority .....	6
1.6 Capability of Other Activities Considered/Potential for Joint Service Cooperation ...	6
1.7 The Advanced Sensor Test Capability (ASTC) .....	6
1.8 Section Overviews .....	7
2.0 ADVANCED SENSOR TESTING METHODOLOGIES .....	7
2.1 Development of the Focal Plane Array Test Chamber for an Advanced Sensor Test Capability .....	8
2.2 Extension to Tactical Systems .....	11
2.3 Concept for ASTC .....	11
3.0 SCENES AND SCENE GENERATION PROCESSING METHODS .....	13
4.0 DWSG LASER-PROJECTION METHODS AND RESULTS .....	20
4.1 Selection of Potential Screen Materials .....	20
4.2 Optical Configurations .....	22
4.3 Evaluation Criteria .....	23
4.4 Code V Analysis .....	23
4.5 Test of Optical Configurations .....	24
4.6 Projection Enlargement .....	27
5.0 CONCLUDING REMARKS .....	28
REFERENCES .....	29

## ILLUSTRATIONS

<u>Figure</u>	<u>Page</u>
1. Concept for AEDC IR Test Capability .....	9
2. Challenge to Integrate DT&E and OT&E Functions .....	12
3. Multi-Level Concept for Sensor Testing .....	12
4. SSGM Image of Southern California .....	14
5. Area of Interest (Catalina Island) .....	15
6. Zoomed Image of Catalina Island .....	15
7. Fractal Interpolation of Catalina Image .....	16
8. Simulated FLIR Image of an Airport .....	17

<u>Figure</u>	<u>Page</u>
9. Actual FLIR Image of a Ship . . . . .	18
10. Actual FLIR Image of a Tank . . . . .	18
11. Actual FLIR Image of a Town Environment . . . . .	19
12. Actual FLIR Image of a Coastal Bridge . . . . .	19
13. Intensity Distribution of Lambertian Diffuser . . . . .	20
14. Performance of Ground Quartz and Flashed Opal . . . . .	21
15. Performance of Spectralon® . . . . .	21
16. ZnSe Samples, Blackbody Source . . . . .	22
17. ZnSe Samples, Visible Source . . . . .	22
18. Optical Configurations for DWSG Projection . . . . .	22
19. Collimator Lens System for DWSG Projection . . . . .	23
20. Spot Size Analysis with and without Collimator . . . . .	23
21. CODE V Analysis of Average Spot Size versus Separation Distance . . . . .	24
22. Experimental Setup for DWSG Projection Testing . . . . .	25
23. Spot Size Measurement Grid (RF frequencies) . . . . .	25
24. DWSG Projection Laboratory Setup . . . . .	27
25. Magnifier Optics . . . . .	28
26. Collimator Optics for Magnified System . . . . .	28

#### TABLES

1. Spot Sizes ( $\mu\text{m}$ ) for No-Screen Configuration, 6.75-in. Separation, at Nine Field Angles . . .	26
2. Spot Sizes as a Function of Separation for No Screen . . . . .	26
3. Comparison of Optical Configurations . . . . .	26

## 1.0 INTRODUCTION

The advent of mosaic array focal planes and the companion high-performance digital processors has led to the development of very sophisticated electro-optical sensor systems. Testing requirements for these systems extend well beyond the mere functional checks of past-generation sensors. Because of the significant investment in both hardware and software development for these systems, it is imperative that evaluation of their operational characteristics be made long before they are fully developed and integrated into their final platform. This report focuses on an approach to providing a ground test capability to evaluate the performance characteristics of the next-generation sensor systems early in their development cycle. It briefly summarizes the types of testing and identifies the technologies which are required for test facilities.

### 1.1 VISION DRIVERS FOR ELECTRO-OPTICAL SENSORS

- Less money to deploy demonstration systems
- More reliance on modeling and simulations
- Integration of software modeling and hardware simulations
- Combination of development and early operational assessment testing
- Networked test facilities and testbeds
- Remote testing
- More complex and integrated photonic sensors
- More autonomous operation
- Multi-use sensors for diverse missions
- Multi-sensor platforms and integrated data fusion
- Off-the-shelf technology

### 1.2 ASSESSMENT OF EXISTING CAPABILITIES

Current ground test chambers can provide evaluation of components and subassemblies of surveillance and seeker systems, but they cannot provide an integrated ground test which uses system hardware to conduct operational tests and evaluations over complete mission profiles. A technical breakthrough in dynamic scene projection technology offers the possibility of developing this interactive real-time ground test capability.

### **1.3 BASIS OF NEED**

The options for evaluation of operational characteristics of surveillance and seeker systems are limited to computer modeling or flight tests of demonstration/validation systems. The first option does not test hardware or flight software and cannot be interfaced to real-time simulations. The second is very expensive and very limited as to the mission issues which can be evaluated. Flight tests for seekers are one-shot data points. Surveillance systems are limited by treaty constraints and costs of providing dedicated threat targets.

### **1.4 NEEDED CAPABILITY**

There is a need for a ground test capability to conduct operational assessment of systems during their development phase long before committing to costly flight and orbital tests. This test capability should be able to provide an operational assessment over the full mission envelope of the system. It should be capable of including full interaction by user personnel and offer the possibility of interfacing the new system into the larger battle management command and control simulations. This capability will permit informed down-select of multiple contractors without the cost of constructing and flight qualifying expensive hardware and incurring the risk of costly flight failures.

### **1.5 PRIORITY**

This test and evaluation capability offers significant cost savings over the present acquisition process. In an environment of tight budgets and limited funding, this new type of test capability is essential. The priority is very high.

### **1.6 CAPABILITY OF OTHER ACTIVITIES CONSIDERED/POTENTIAL FOR JOINT SERVICE COOPERATION**

This test capability provides early operational assessment for the Air Force, Army, and Navy. It can provide ground-based simulations for distributed interactive simulations (DIS) where interactions between all service elements of a battle plan are exercised. It should be supported by all the services.

### **1.7 THE ADVANCED SENSOR TEST CAPABILITY (ASTC)**

The advanced sensor test complex is conceived as an ensemble of ground test simulations which can provide full-mission performance testing of interactive sensor systems. It is based on the AEDC laser-based direct write scene generation technology, but also adds the capability for system emulators and computer-based signal injectors. The objective of the complex is to provide program developers the capability of exercising their systems over the full range of operational envelopes. In many cases these will extend far beyond anything that would be possible in any type of field test or direct flight. This is especially important in testing a system's performance under a battlefield environment.

## 1.8 SECTION OVERVIEWS

The following sections describe efforts to support technology developments for advanced sensor testing at AEDC. Section 2.0 discusses advanced sensor testing methodologies. Section 3.0 reviews efforts to generate and obtain complex scenes for sensor testing with some emphasis devoted to fractal interpolation. Section 4.0 discusses efforts to develop an optical projection method to extend the capabilities of the direct write scene generation methodology. Section 5.0 provides concluding remarks.

## 2.0 ADVANCED SENSOR TESTING METHODOLOGIES

Modeling and digital simulations are destined to play an ever more significant role in the development of new systems. In the past, most modeling was not accomplished in real time. The modeler accounted for time-critical events, but the computing power was not available to consider real-time simulations. For example, a ground-to-air seeker model which accounted for all the functional aspects of the rocket thruster, the flight profile, the guidance unit, and the sensor might take 24 hours of computational time to simulate a 15-sec real-time mission. The development of massively parallel processing and the use of emulators and segments of real hardware promise the possibility of real-time simulations. This new concept for systems acquisition will impact both the way that system models are developed and the type of ground test capabilities that are built. This report focuses on systems which are built around electro-optical sensors. The critical components of these systems are the focal plane detectors and the associated data processors with their software.

The development of a particular military system starts with a definition of a strategic or tactical need. This need, coupled with a description of the battle environment, is used by a contractor to develop a concept for a system which will meet the need. The contractor operates with several constraints. One is the state of the art of the technologies which will be required. Another is the availability or "buildability" of the envisioned hardware. In addition, the system must be affordable and deliverable within a reasonable, and usually short timeframe. The combination of these challenges and constraints has led to several general acquisition strategies. The first is to ensure that critical components or systems will be available. This is translated to a philosophy of using commercial off-the-shelf (COTS) equipment. For sensor systems, this means choosing focal plane arrays that are produceable and thus available early in the program. This does not preclude the development of a next generation and more capable focal plane. However, this would be seen as an upgrade to the system, not its primary configuration. Another strategy is to use more modeling and simulation in place of building prototypes and conducting field tests. Modeling has always been a part of development. However, in the past there has been little coordination between the many models which have been developed. For example, computer-aided design of airframes has been coupled to computer-aided machining (CAD/CAM). However, when modelers needed airframe contours for developing computer models of airflows, they built their own wireframe models. Recent programs now use the same models for designing hardware and as the inputs for defining wind tunnel flows. These in turn are used to develop stores release models to determine the effectiveness of weapons delivery.

The new test methodology is based on the philosophy that modeling and simulation (M&S), development testing (DT), and operational evaluation (OE) should be planned as a unified whole. For example, those involved in developing the early phase models for such analysis as heat transfer, structural rigidity, inertial stability, optical fidelity, etc., should consider the later requirements for modeling and simulations which will require the interfacing of computer simulations and hardware. These later models should either be extensions of the first-principle physics models of the design phases, or be traceable to them. Similarly, the early tests which are conducted to determine if the components meet specifications should be planned to either supplement or transition into tests which can evaluate the eventual operational characteristics of the system.

Performance testing can begin when the focal plane of the sensor is operational and coupled to the data processors. At this level of integration, the mission scenarios can be written on the focal plane. Since the telescope and gimbal systems are not present, they must be emulated and coupled to the driver for the mission scenes. The telescope is incorporated as an optical transfer function which is used to define the blur spot for the images. The scan motions of the gimbals which control the location of the scenes on the focal plane are incorporated as a real-time digital model of the mechanical and electrical components. At this point in the performance testing, these parameters are defined from the engineering models of the equipment. It is possible to add distortions and jitter to the scenes to simulate worst-case conditions for these components.

The second level of performance testing occurs when the telescope and gimbals are integrated and these tests are conducted in a test chamber with an optical collimator. This test chamber is used to calibrate the system for optical properties such as boresight, optical transfer function, jitter, radiometric sensitivity and uniformity, etc. These data are used to provide the parameters for the next level of performance testing.

The third level of performance testing is conducted once again at the focal plane level. In these tests, the mission scenes that are written on the focal plane use a simulated optical transfer function of the real telescope and the jitter associated with the operation of the scan systems.

A fourth level of performance testing can take several focal planes from different sensors and simultaneously write on each, thus presenting the mission scenario seen from that particular sensor's point of view. This level of performance testing extends performance testing into the realm of OT&E testing. It not only evaluates the synergistic performance of several pieces of equipment, but also includes the operators and their interactive human judgments and interpretations. This provides an evaluation of the effectiveness of the system under simulated battlefield operations.

## **2.1 DEVELOPMENT OF THE FOCAL PLANE ARRAY TEST CHAMBER FOR AN ADVANCED SENSOR TEST CAPABILITY**

The ability to provide the types of tests suggested in the new test methodology relies on developing a real-time capability for the IR laser projection testbed (FPATC) and adding signal injection and mosaic array projection technologies.

Figure 1 presents a block schematic of an approach for the extension of the AEDC IR test facility. The solid gray blocks depict the capabilities that currently exist. The lower right blocks which identify the mosaic heater array, a heater-array processor, and collimator are installed in AEDC Aerospace Chamber 7V and are capable of projecting a dynamic IR scene. However, the processor is quite limited and only able to address a small portion of the heater elements at a time. The IR projection system which exists is shown at the upper left of Fig. 1. The prescribed scenarios are stored on a disk farm, and, at the beginning of a test sequence, they are fed to the parallel processors which convert the input scene data to the RF signals needed to drive the IR laser projector. The IR laser in turn writes the scenes on the focal plane of the sensor under test. In the current system, the parallel processors and the RF signal generators are all included on the same electronics board. Figure 1 shows them separated, which is the proposed new configuration.

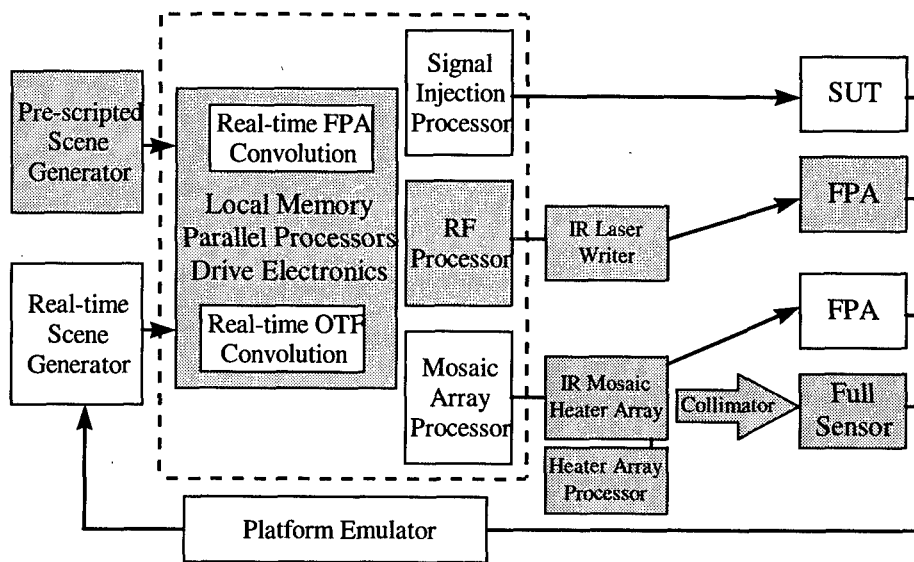

**Figure 1. Concept for AEDC IR test capability.**

The signal injection module will take the scene data frames and perform a convolution to convert the irradiances to focal plane or post-processor signals to be injected into the system under test (SUT). This test capability is most useful for equipment that has reached the prototype or installed level of development. An example would be a Forward-Looking Infrared (FLIR) sensor that is to be installed on an aircraft.

The function and design of the RF modules would be similar to those already built for the current system. The mosaic array module would convert the irradiances to appropriate signals to drive the heater array. Since the primary use of the laser system is to project directly on the focal plane, an optical point spread function which adds the effects of the sensor telescope must be convolved with each scene frame.

For those tests where the heater mosaic array is used to evaluate a focal plane of a system, the optical transfer function, which will eventually be used for the sensor along with the calibration constants, will be added to the scene data. In those instances where the array will be coupled to the sensor through a collimator, the transfer function would include the radiance calibrations, but would not include the optical transfer function of the telescope of the SUT.

Since the ASTC extends the development test (DT) capability to provide a level of early operational assessment (EOA) for systems incorporating electro-optical sensors, the prescribed scenario capability must be upgraded to a real-time scene generator system. This is shown as an alternate input for the scenes in Fig. 1. In addition to the capability of generating each scene frame in real time, there is also a need for emulators which provide signals or data from equipment which is either not available or cannot be operated in the ground test facility. The final output of the emulation system is the pointing vector which is used to select the field of regard frame from the scene database. The simplest device for this task is a mouse or a joystick which is operated by a human in the loop. An example would be someone who was observing the output of the projected scenes on a visible monitor and possibly trying to track a moving object by overlaying a spot cursor. In this case the emulator would consist of the human and the joystick. More complex emulators could include combinations of operational hardware, digital simulators, analog systems, and human inputs. An example of one of these complex interfaces is envisioned for the installed system test and evaluation facilities (ISTEF) at the Naval Air Warfare Center (NAWC) at Patuxent River and the Air Force ISTEF at Edwards Air Force Base. In each case, the aircraft with the equipment under test will be installed in the ground test facility and the pilot will be in an adjacent room in a mockup of the cockpit with a surround projection screen. A visible scene generator will project the scenes onto this screen. It will respond to orientation vectors determined from the plane flight emulator which in turn is responding to pilot inputs as he "flies" the plane. Coupling this simulation to an IR projection system which could respond to the plane's maneuvers and stimulate an installed FLIR system would provide an added degree of operational test and evaluation of this weapon system under simulated battle conditions. The ISTFs are pursuing the acquisition of a real-time scene generation system; thus, this is of extreme importance to us as an integral part of the AEDC ASTC.

There are three additional factors which must be considered in the redesign and building of the parallel processors for the next-generation sensor test capability. Because the system must respond at rates which match the clocking frequencies of the various sensor focal planes, it will be necessary to close-couple the database from which each of the scene frames will be selected. At the same time, the overall database of a mission may require terabytes of data. One approach to this problem might be to have sufficient memory on the processor board to accommodate several seconds of the scenario with the larger database in separate memory. As the mission progresses and the selected scene frames start to approach the bounds of the onboard memory, additional data would be scrolled in to replace the obsolete onboard database.

A second factor to be considered is the application of the optical transfer function for those tests where the sensor telescope is either not available or it is more appropriate to bypass the optics. Since the scenario is not predetermined, the optical transfer function must be applied to each frame prior to projection or injection. Thus, the parallel processors must perform the addi-

tional task of applying the OTF transforms. As illustrated in Fig. 1, there is a similar requirement for a focal plane transform for those applications where the focal plane and some of the preconditioning electronics are bypassed for signal injection testing. In these cases, it will be necessary to perform both the OTF and the FPA transforms.

The test objectives for validation of a space system can be considered at four levels. The first is to verify that the system as constructed meets specifications. This level of testing can be described as calibration and characterization. It requires test facilities capable of simulating the space environment and providing high-fidelity infrared sources and extremely stable line-of-sight alignment capabilities with National Institute of Standards and Technology (NIST)-traceable measurements.

The final level will extend third-level testing to provide a network for testing multiple systems, thus permitting a program such as a Brilliant Eyes or ALARM to interface with other elements of the defense architecture such as the ground-based interceptors (BPI, THAAD, or EKV) and the battle management elements (BMC3). This level involves networking between test facilities and can support OT&E and operator training.

## **2.2 EXTENSION TO TACTICAL SYSTEMS**

With the dynamic and interactive maneuvers required for tactical missions, testing requirements for tactical systems are more stressing than strategic systems. Tactical aircraft such as the F-18 and F-22 employ advanced state-of-the-art electro-optic sensor systems that require characterization and evaluation for developmental testing and operational testing. The more demanding missions of tactical aircraft require high-speed 3D-to-2D processing and optical convolution simulation needed for the ASTC-level testing.

## **2.3 CONCEPT FOR ASTC**

In the conventional system's acquisition approach, there is no Air Force integration of DT and OT as the hardware matures from the component level through to the final in-flight aircraft or on-orbit satellite as illustrated in Figs. 2-3. Digital modeling is the primary (and, in many cases, the only) tool available to provide early operational assessment. Incorporation of operational satellite hardware has been a desirable but elusive goal. The primary barrier has been that the ground test facilities have been extremely limited in their scene projection capabilities.

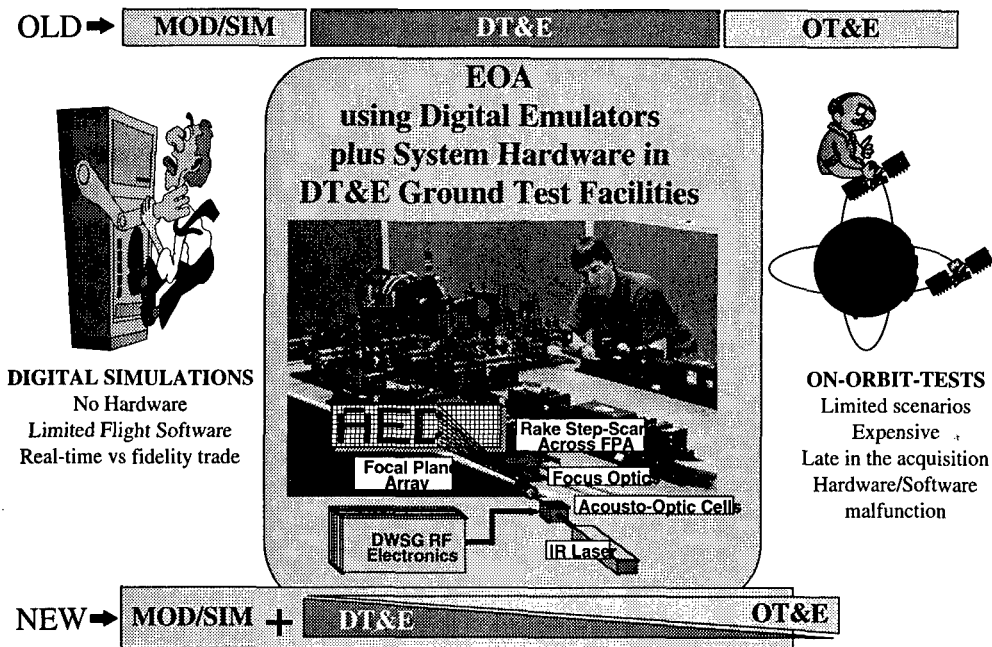

Figure 2. Challenge to integrate DT&E and OT&E functions.

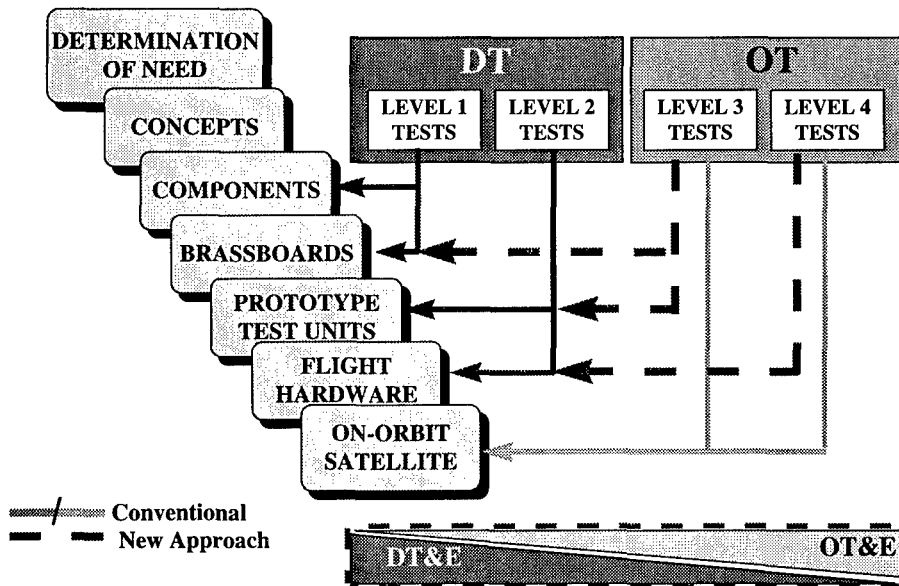

Figure 3. Multi-level concept for sensor testing.

The proposed approach uses state-of-the-art scene projection technologies which have been developed through the Air Force CTEIP program, coupled with closed-loop test techniques to enable Level 3 and 4 testing earlier in the system hardware development cycle, as noted in Fig. 3.

Once brassboard units for the sensor have been developed, i.e., focal planes, signal processors, target detection and tracking algorithms, etc., the system being developed can be exercised over entire threat mission profiles in ground test facilities. Then later in the acquisition cycle, prototype test units can also be tested to ensure system integration has been successful.

Using the proposed test approach, flight-designed hardware installed in ground test chambers and coupled with emulators can provide an evaluation of the system as it will interface with the overall defense architecture. This will permit operators to interface with the surveillance system and the other battle elements through network data links.

Finally, operational tests can be performed with the flight-qualified system in flight or on-orbit with human controllers already experienced and practiced in system operation and thoroughly familiar with data interpretation.

### 3.0 SCENES AND SCENE GENERATION PROCESSING METHODS

This section provides a discussion of IR scenes and scene generation processing methods. Some time was devoted to collecting and analyzing actual IR data to determine what refinements were desirable in the scene description parameters. Preliminary scene description parameters had been previously developed in FY95. These parameters were the scene mean, standard deviation, and spectral exponent ( $\beta$ ). The mean and standard deviation of the scene were calculated in the standard way. The spectral exponent or spatial high-frequency roll-off was determined by taking the power spectral density of the scene data and finding the exponent which most closely matches the high-frequency roll-off assuming a  $1/f^\beta$  behavior.

The satellite data used were collected by the Advanced Very High Resolution Infrared Radiation (AVHRR) satellite maintained by the National Oceanic and Atmospheric Administration. This satellite provides approximately 1-km ground resolution data in 0.58 to 0.70-, 0.72 to 1.0-, 3.6 to 4.0-, 10.3 to 11.3-, and 11.5 to 12.5- $\mu\text{m}$  wavebands.

Detailed analysis of many actual satellite images indicated that a constant mean, standard deviation, and spectral exponent were not sufficient to describe a scene with variable types of terrain. For example, large bodies of water tend to have a low relative standard deviation when compared to land areas. The characteristics of clouds were also very different from typical land scenes. Because of this, the scene generation program was modified to allow for variable mean and standard deviation parameters. Instead of a constant mean or standard deviation over the entire scene, the scene was subdivided into 8 by 8 regions. A different parameter could be specified for each of the 64 elements, allowing for some variation across the scene.

An investigation of fractal methods indicated their potential usefulness in creating scenes with varying spectral exponents. Based on papers by Jaenisch (Ref. 1) and Musgrave (Ref. 2), a

fractal-based routine was written which allows scene generation based on fractal interpolation. One of the advantages of this approach is the ability to artificially increase the resolution of a given scene, allowing for infinite zooms. Fractal-based scene generation uses a low-resolution approximation of the desired scene with a predefined mean, standard deviation, and spectral exponent at each pixel. Any number of final scenes can be created based on this single low-resolution image. Although each high-resolution scene will vary randomly in detail, they will all share the same predefined statistical properties. An example of fractal interpolation is illustrated in Figs. 4-7. Figure 4 illustrates a near-infrared (2.3 to 2.5  $\mu\text{m}$ ) scene of the southern California area generated by the Synthetic Scene Generation Model. Figure 5 illustrates an area of the scene centered on Santa Catalina Island which is then magnified to show the individual pixels. Figure 6 is the magnified section, and Fig. 7 illustrates the results of using fractal interpolation to artificially increase the resolution.

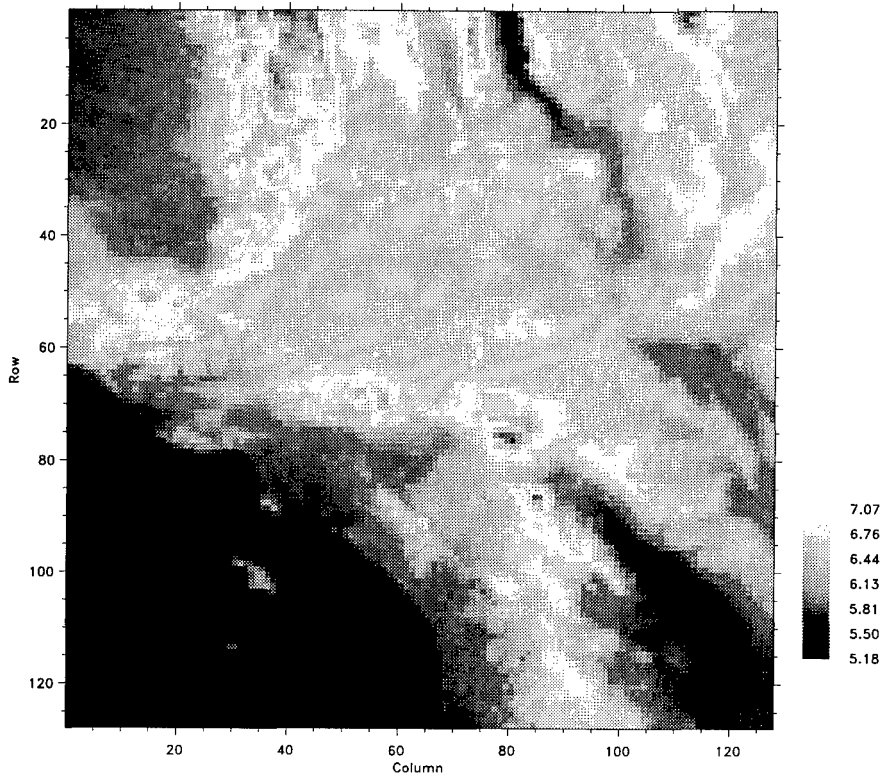

**Figure 4. SSGM image of southern California.**

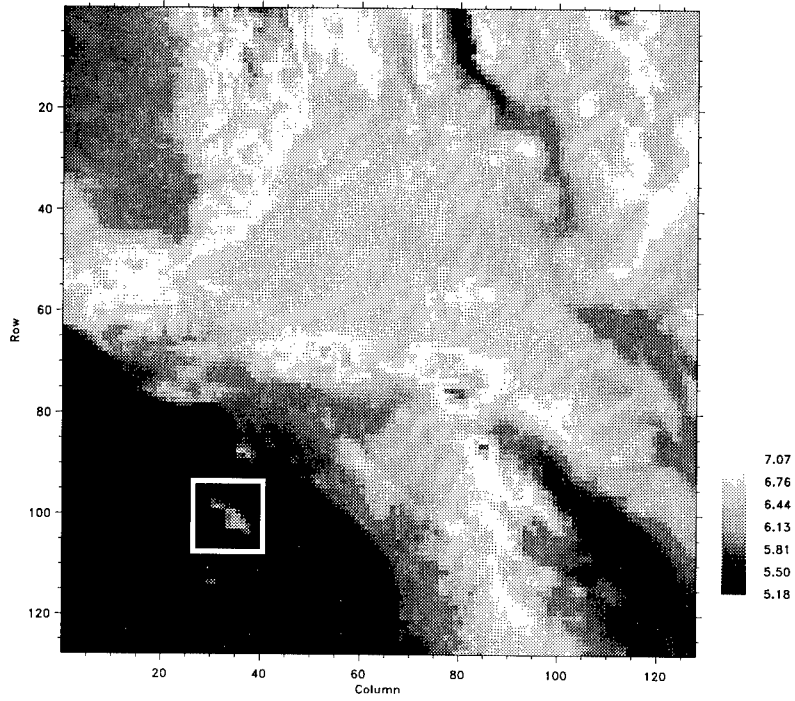

Figure 5. Area of interest (Catalina Island).

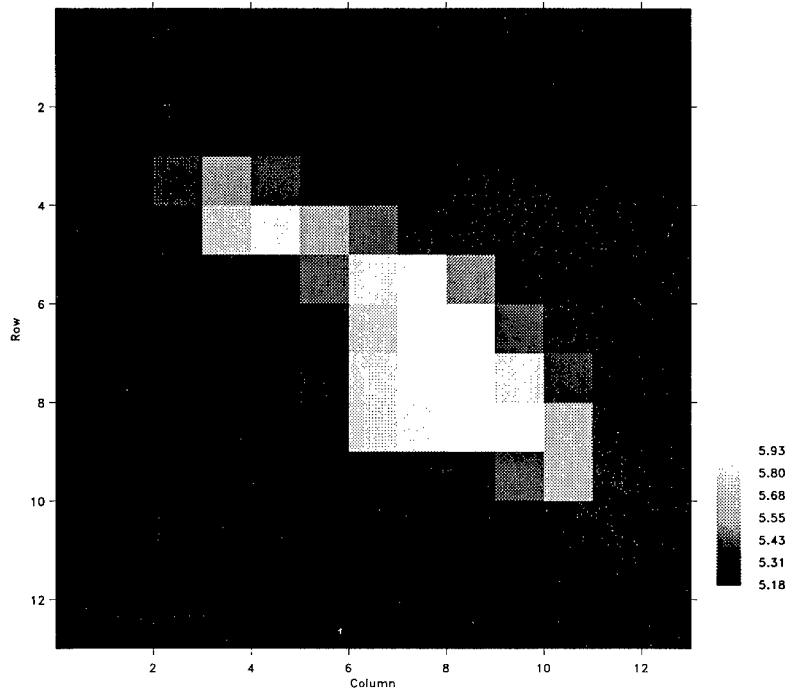
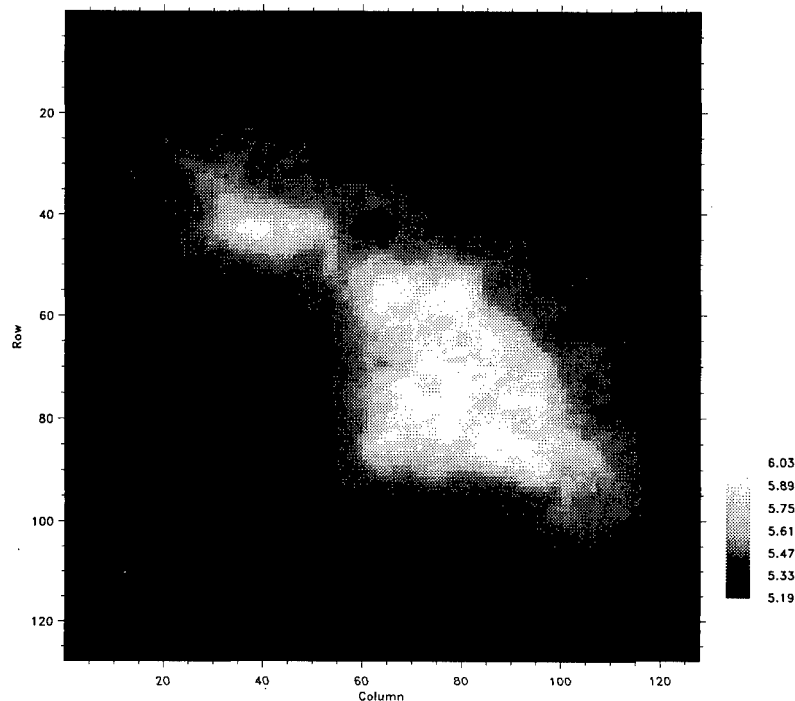

Figure 6. Zoomed image of Catalina Island.



**Figure 7. Fractal interpolation of Catalina image.**

Clouds can be generated in a similar manner and combined with the background terrain. This allows greater flexibility by characterizing the cloud scene with one set of parameters while the terrain background uses another set of parameters.

Efforts were devoted to provide an approximate order of magnitude reduction in program execution time. A combination of more efficient coding and the purchase of a faster computer system provided an overall reduction by a factor of seven in scene creation execution time.

In addition to scene creation, an efficient method of storing existing scenes using wavelet techniques was also investigated. After reviewing several papers on this subject, an IDL (Interactive Data Language from Research Systems, Inc.) routine was written to compress scenes using wavelet procedures. Compression factors of ten or more were achieved with minimal loss of fidelity in the restored scene. Efficient low-loss or no-loss scene storage will probably be necessary in the overall program if high-resolution scenes are to be used.

An IDL program was written to determine the spectral exponent (spatial high-frequency rolloff) for any scene. This program, along with a program to use a specified mean, standard deviation, and spectral exponent can be used to construct each scene pixel. The wavelet-based program is useful to store the resulting scene efficiently.

One scene generation effort was to deliver five sample scenes illustrating the various characteristics necessary to demonstrate a working synthetic scene generation capability for tactical systems. The five scenes represent FLIR images and illustrate both simulated and actual data. Figure 8 illustrates a typical airport scene with buildings in the background. This simulated scene was created by the Camber Corporation's Washington Technology Center. The following four figures represent actual FLIR data from the Naval Air Warfare Center Weapons Division (NAWC-WD). Figure 9 is an image of a ship with some random water reflections. Figure 10 is a close-up image of a tank. Figure 11 illustrates how land targets can be hidden in a town environment, and Fig. 12 illustrates a coastal bridge scene.

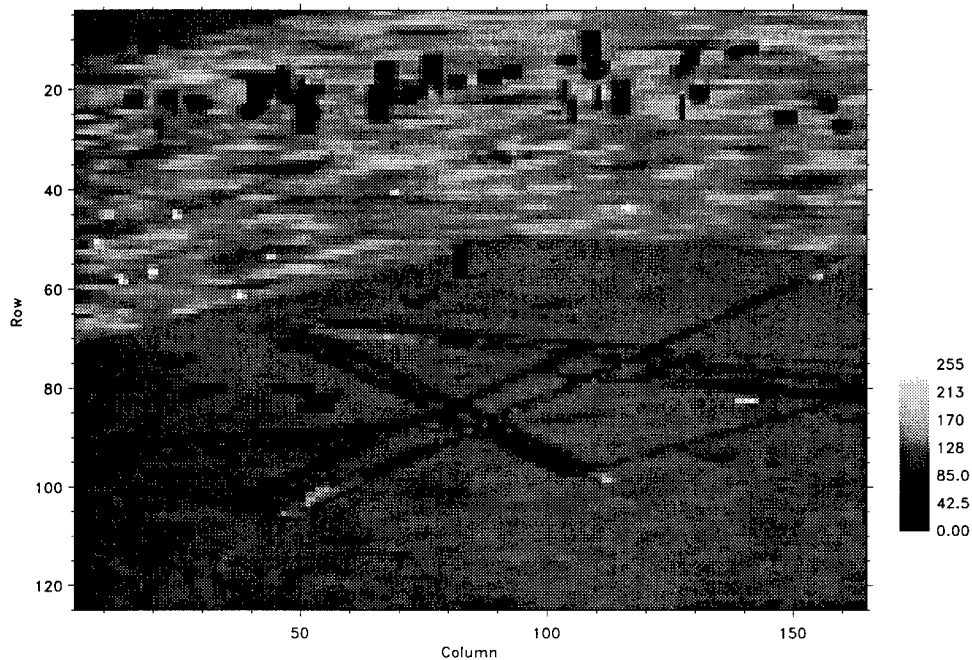

**Figure 8. Simulated FLIR image of an airport.**

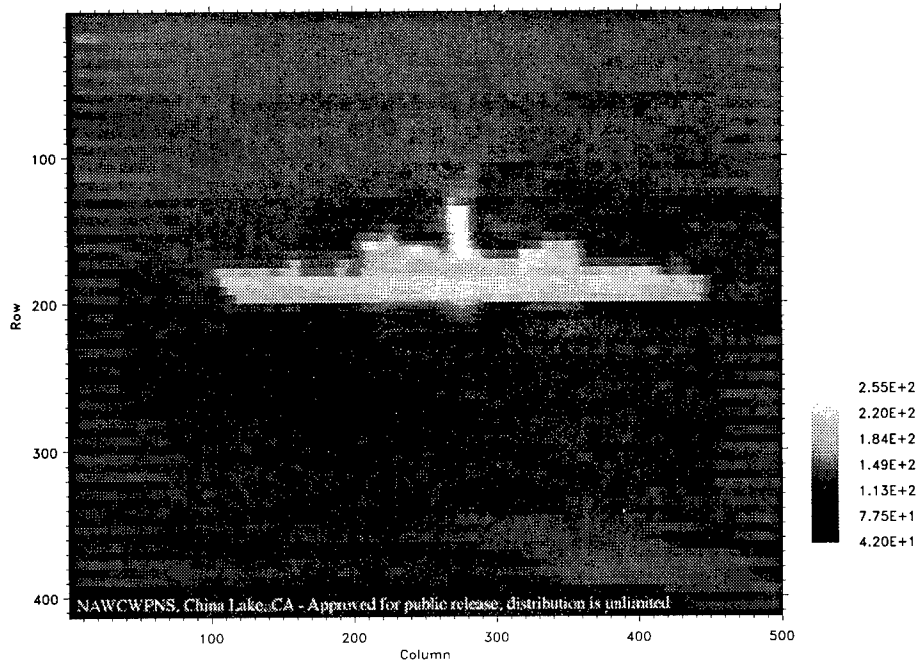

Figure 9. Actual FLIR image of a ship.

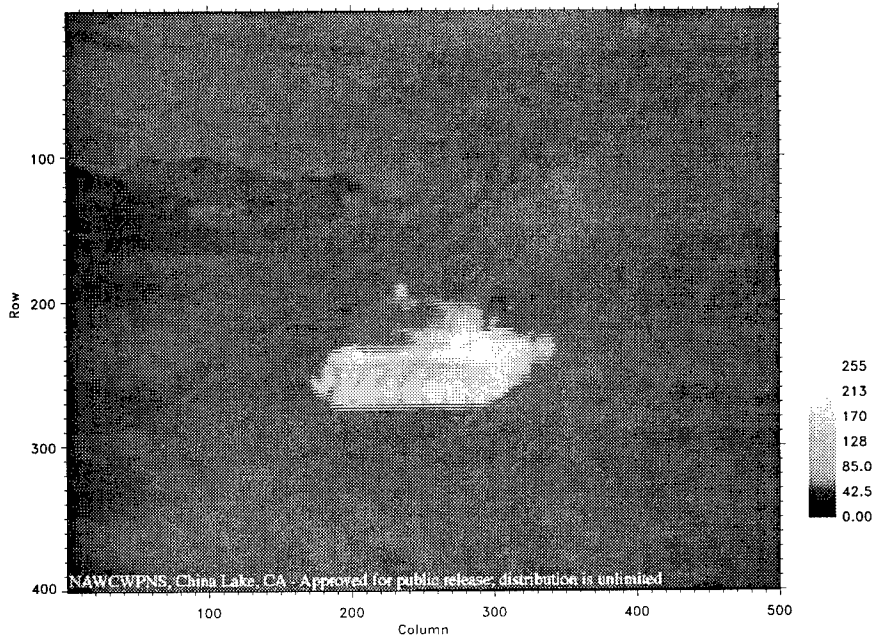

Figure 10. Actual FLIR image of a tank.

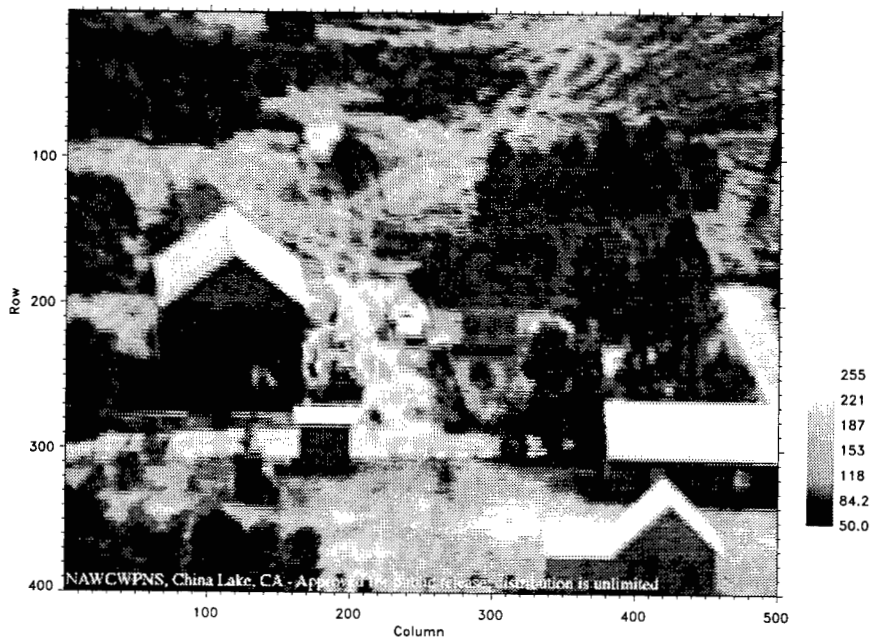

Figure 11. Actual FLIR image of a town environment.

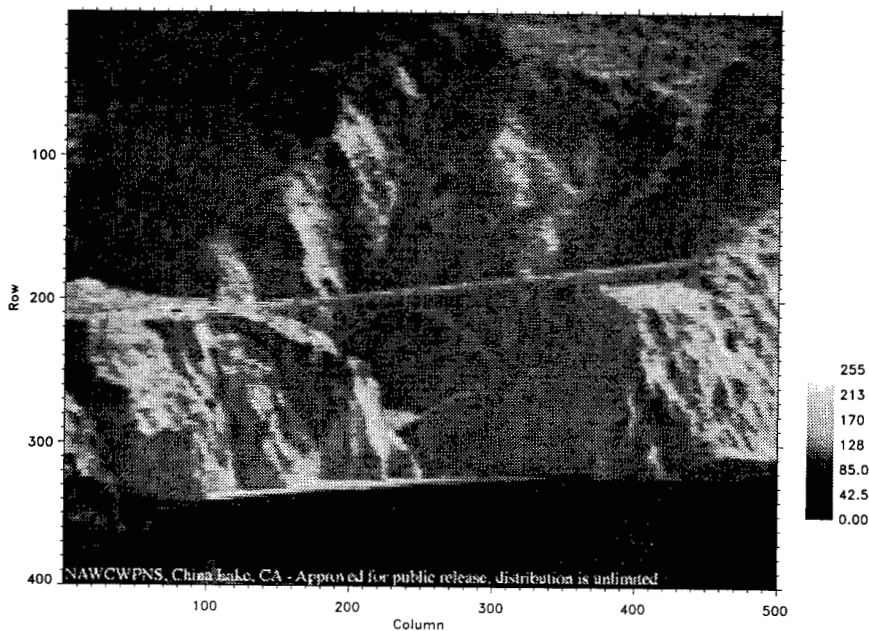

Figure 12. Actual FLIR image of a coastal bridge.

#### 4.0 DWSG LASER PROJECTION METHODS AND RESULTS

The DWSG Focal Plane Array Test Capability (FPATC) includes lasers operating at 0.514, 1.06, 5.4, or 10.6  $\mu\text{m}$  and acousto-optic (AO) modulators for laser-beam control. High-speed RF electronics use Direct Digital Synthesis (DDS) to drive the AO modulators and deflectors with multifrequency input for multibeam output. DDS frequency modulation provides extremely accurate and independent deflection of the multibeam laser "rake." Similarly, DDS amplitude modulation provides accurate and independent multibeam intensity control. Laser beam scan optics focus the laser beams onto subpixel regions for pixel-to-pixel photoflux deposition with minimal stray radiation from diffraction. The laser beam rake is then step-scanned across the FPA during each integration period. Several technical references (Refs. 3 - 7) provide details.

One of the objectives of the Space Sensor T&E Technology Project is to investigate the viability of extending the Direct Write Scene Generator (DWSG) capability to enable inclusion of the sensor system's optical train in a DWSG test. The test methodology would employ a collimator to redirect radiation from the image plane of the DWSG projection (possibly using a transmissive or reflective screen) through the sensor optics onto the sensor focal plane array (FPA).

#### 4.1 SELECTION OF POTENTIAL SCREEN MATERIALS

The purpose of a transmissive screen would be to provide a diffuse source for each projected spot which can be re-imaged at the image plane of the sensor system. An ideal diffuser produces an output that follows a Lambertian cosine distribution law, as illustrated in Fig. 13. For such a surface the radiance is independent of viewing angle. A blackbody follows the Lambertian law exactly. Some real targets approximate this radiative quality, depending on their spectral emissivity. The radiation from real targets would be essentially collimated due to the typically large distances between targets and sensor. The radiance from an in-chamber source must be collimated to fill the sensor optics so that the proper optical performance can be obtained during the scene generation process.

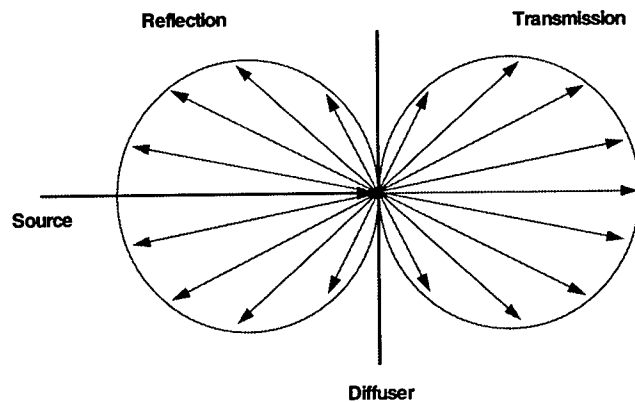

Figure 13. Intensity distribution of Lambertian diffuser.

There are some commercially available diffuser materials: (1) ground quartz, (2) flashed opal, and (3) Spectralon<sup>®</sup> (trademark name of Labsphere, used in integrating spheres, reflective only). The output (intensity versus angle) as compared to a perfect Lambertian source is shown in Figs. 14-15. The orientation of Fig. 14 is rotated 90 deg counterclockwise from Fig. 13; only the transmission portion is shown. The orientation of Fig. 15 is rotated 90 deg clockwise from Fig. 13; in this case, only the reflection portion is shown. It is clear that the flashed opal and Spectralon<sup>®</sup> are very close to Lambertian. Samples of these three materials have been procured for use at AEDC.

A transmissive diffuse screen must scatter the transmitted radiation into the sensor optics. Some of the scattered radiation is detected by the sensor, but the majority of it is out of the field of view. Ideally, the screen would be just diffuse enough to fill sensor optics with a minimum of lost radiation. Work has been performed previously at AEDC to measure the performance of various transmissive diffuse screens. The materials involved with this study are zinc selenide (ZnSe) and germanium (Ge), with diffuse surfaces prepared by four different techniques: (1) Airbrasive blasting (similar to sand blasting with silicon carbide grit), (2) Grinding (by hand with silicon carbide and water), (3) Liquid honing (silicon carbide slurry sprayed against the substrate), and (4) Chemical etching (using nitric acid).

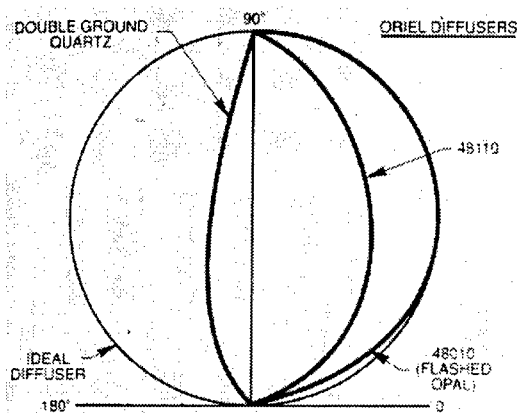

Figure 14. Performance of ground quartz and flashed opal.

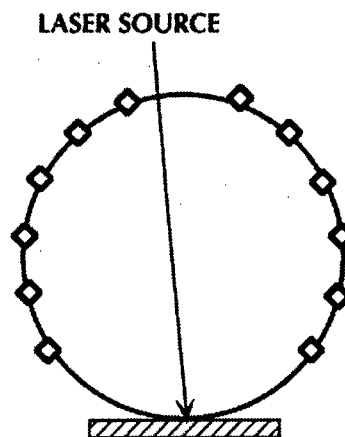

Figure 15. Performance of Spectralon<sup>®</sup>.

This technology was used in the Kinetic Kill Vehicle Hardware-in-the-Loop Simulator (KHILS) Scophony infrared scene projector (IRSP) developed by AURA systems (Ref. 8). In fact, some of the materials used in the AEDC study were given to the KHILS program for their use. An additional screen (hand ground) was prepared especially for that program by AEDC in a successful attempt to provide a desired scattering distribution. Examples of the measured distributions for ZnSe samples, with different surface properties, are shown in Figs. 16-17 for blackbody and visible source radiation. The hand-ground ZnSe samples were chosen as the fourth sample for the DWSG projection studies, as needed.

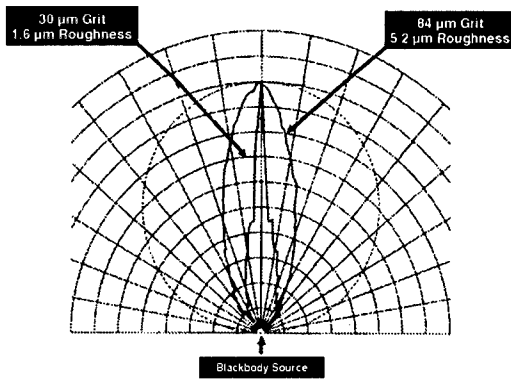

Figure 16. ZnSe samples, blackbody source.

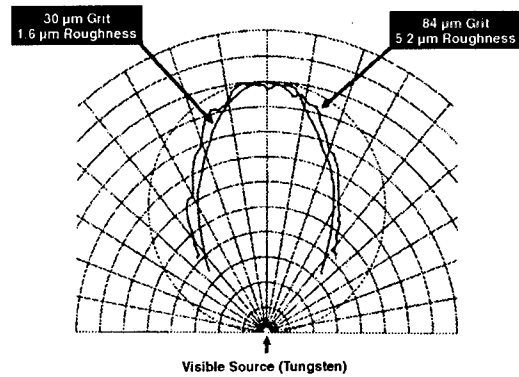

Figure 17. ZnSe samples, visible source.

#### 4.2 OPTICAL CONFIGURATIONS

Several optical configurations were considered in the investigation of DWSG projection; these are shown in Fig. 18. CODE V optical analysis was performed to a limited extent for configuration #1, but because early experimental data manifested the possibility of good results without using a screen at all, the full CODE V optical analysis effort was directed to configura-

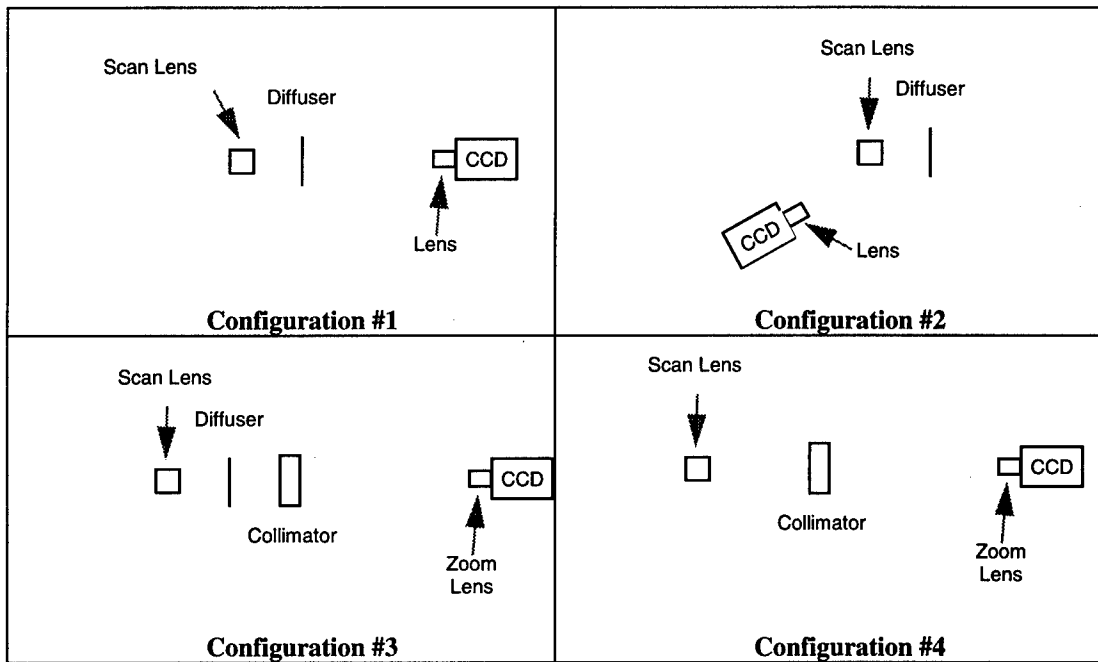

Figure 18. Optical configurations for DWSG projection.

This configuration uses a lens system to collimate the projection from the DWSG so that a camera looking at infinity would be able to re-image it at the camera's FPA. Focal planes with the optics attached are generally designed to look at an object or target at infinity. This means that the light coming from that target is collimated. By generating a scene using the DWSG, imaging that scene, and then collimating it, the target can be made to seem as though it is far away. The collimator lens system for configuration #4 was designed using CODE V, and is shown in Fig. 19.

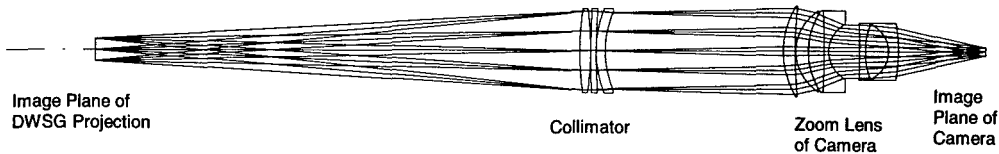

Figure 19. Collimator lens system for DWSG projection.

#### 4.3 EVALUATION CRITERIA

Because mapping of energy in the form of spot size over the image plane is a standard means of determining the fidelity of an optical system, this was the criterion chosen to be used in the evaluation of the projection of the DWSG through the sensor's optical system. This criterion (as defined by the 90-percent encircled energy diameter) was used during the hardware testing of the SGTC; the measurement hardware and experience are available and will provide the best means of demonstrating the goals of this project.

#### 4.4 CODE V ANALYSIS

To check the analyzed performance of the collimator, the focused spot size on the focal plane was compared to what the camera would see if the object were actually at infinity. A comparison between the use of truly collimated light (object at infinity) and light from the DWSG as transmitted through the designed collimator is shown in Fig. 20. The spot sizes indicate a maximum error of 10 percent at the corners of the image plane, with errors as small as 2 percent at the center.

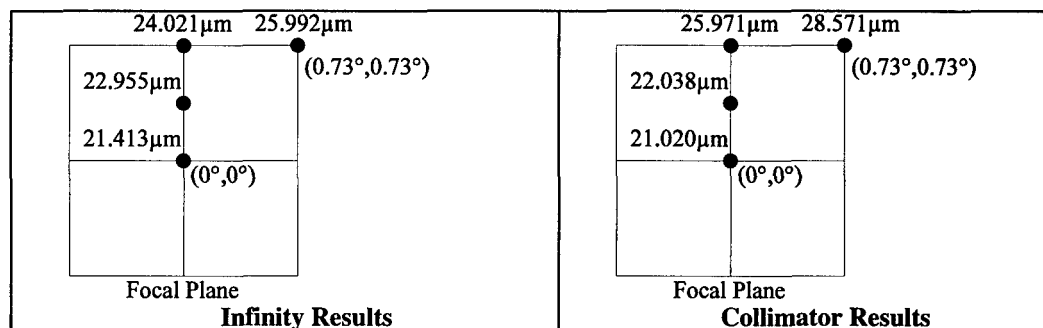

Figure 20. Spot size analysis with and without collimator.

These particular spot-size values depend primarily on the camera lens, not the collimator; but these data do show how well the collimator performs. Other camera lenses or focal plane optics might give different spot sizes, but the correlation of the spot size with the source at infinity to the spot size using the collimator should be consistent. Analysis of the spot sizes in the image plane as a function of the distance between the collimator and the camera lens diameter (D) is illustrated in Fig. 21. The spot size tends to get larger at greater separation distances due to the aperturing effect of the collimator.

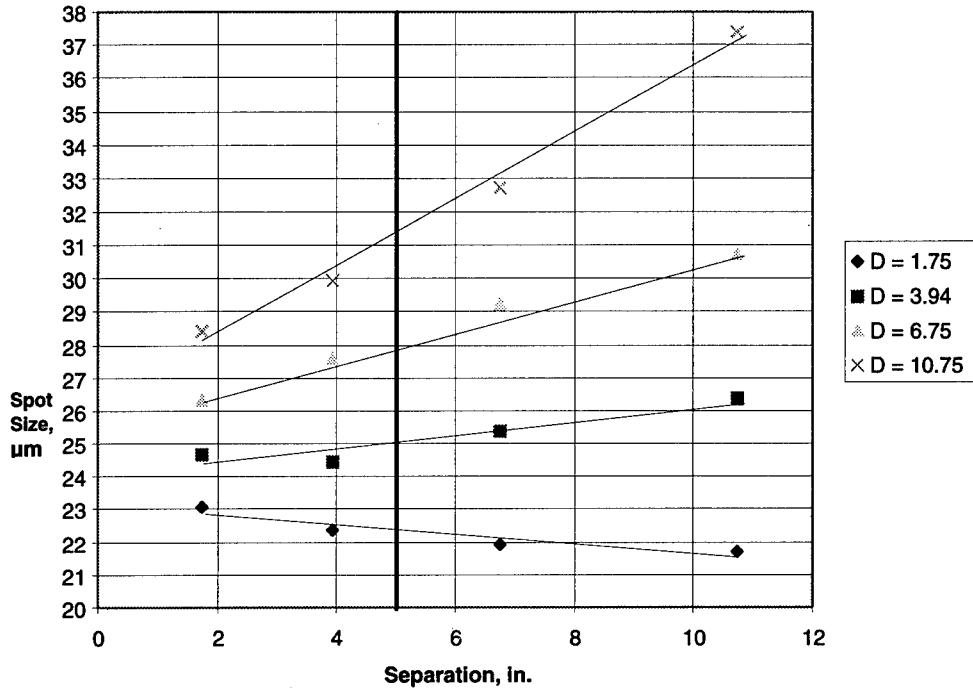

Figure 21. CODE V analysis of average spot size versus separation distance and optical diameter (D).

#### 4.5 TEST OF OPTICAL CONFIGURATIONS

The initial collimator lens system was designed using three off-the-shelf singlet lenses. This assembly collimates the light coming from the scene created by the DWSG. Test data were obtained on three optical configurations (no screen, flashed opal screen, and ground glass screen) at nine different field angles (corresponding to nine different spatial locations in the image plane). In one configuration, measurements were made at four different separation distances between the collimator and the camera lens.

The experimental setup is shown in Fig. 22. The nine different field angles were examined in the focal plane of the projection as the position in the grid shown in Fig. 23. The numbers represent the RF frequencies which correspond to the scan angles which produce a spot at these locations. Beam scan diagnostic instrumentation was used to measure the size of the spot in the vertical and horizontal axis. Measurements were first made without a screen in the optical path. Data from each of the nine field angles for a collimator/lens separation of 6.75 in. are shown in Table 1. Average data for each separation distance are shown in Table 2, along with the average spot size from the CODE V analysis. A comparison of data for the three configurations is shown in Table 3 for a separation of 5 in. The optical losses for the flashed opal screen and ground glass screen are 17 and 15.5 dB, respectively.

The ground glass material appears to have less optical spread and attenuation, thus making it the best of the tested screen materials. However, it is clear that using no screen at all provides the best spot size. All of the measurements are within the established criteria of 20 percent relative to the CODE V analysis. The laboratory setup is shown in Fig. 24.

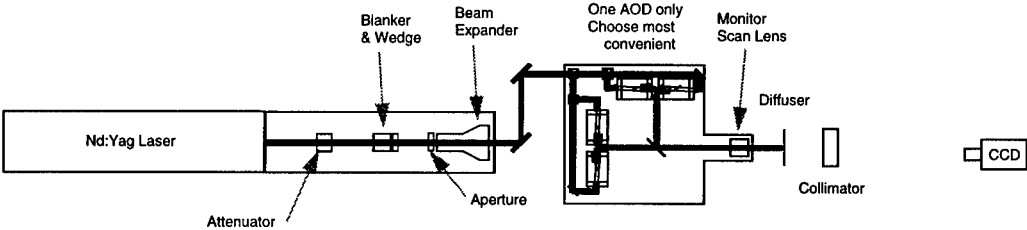

Figure 22. Experimental setup for DWSG projection testing.

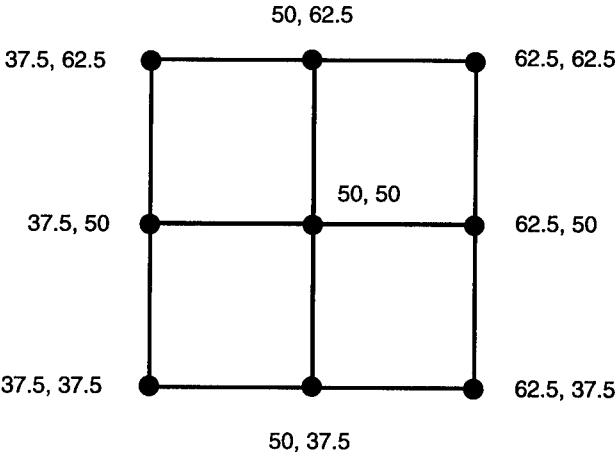

Figure 23. Spot size measurement grid (RF frequencies).

**Table 1. Spot Sizes ( $\mu\text{m}$ ) for No-Screen Configuration, 6.75 in. Separation, at Nine Field Angles**

27	18	49
28.5	17.5	33.5
29.5	27.5	44.5

**Table 2. Spot Sizes as a Function of Separation for No Screen**

Separation, in.	Measurement, $\mu\text{m}$	Analysis, $\mu\text{m}$	Percent Difference
1.75	29.9	27.36	9.28
1.75	26.39	26.89	-1.85
5.0	25.44	28.52	-10.79
6.75	30.56	29.98	1.91
10.75	34.33	32.71	4.97

**Table 3. Comparison of Optical Configurations**

Configuration	Measurement, $\mu\text{m}$	Analysis, $\mu\text{m}$	Percent Difference
No Screen	25.44	28.52	-10.79
Flashed opal	33.5	28.52	17.45
Ground Glass	30.22	28.52	5.96

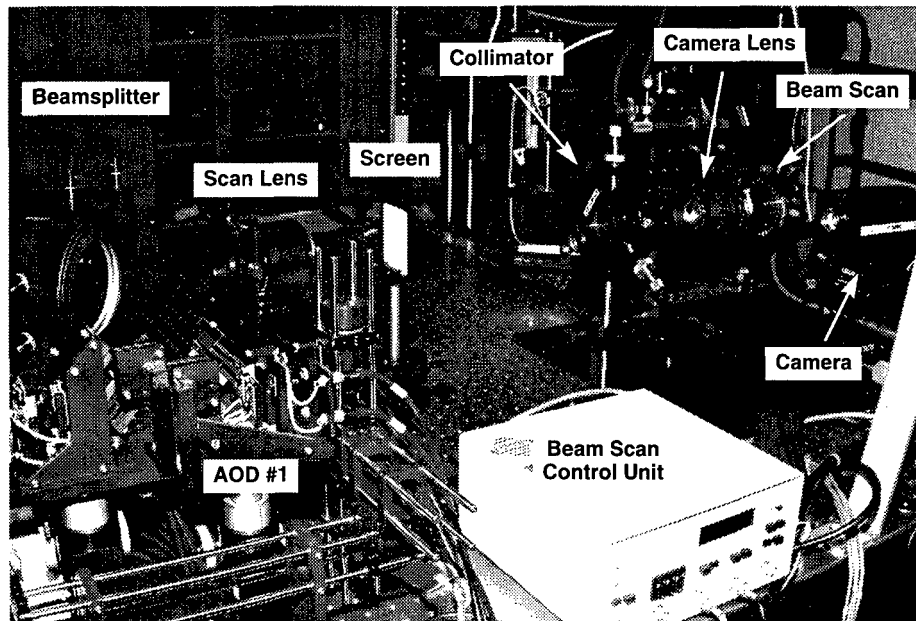

Figure 24. DWSG Projection Laboratory setup.

#### 4.6 PROJECTION ENLARGEMENT

The collimator system previously discussed was designed to show the capability of using the Direct Write Scene Generator (DWSG) to test focal planes with focusing optics included. Another optical system was designed to allow the focal plane to look at a larger scene so that testing of a larger focal plane area is possible. This system was designed using off-the-shelf catalog lenses, thus greatly reducing the cost (~\$500 instead of \$6-8K for a custom assembly).

The second system created consists of a magnifier and a collimator. The magnifier is a four-element lens assembly that magnifies the image from the DWSG as presented on the camera FPA to 3.5 times the original size (from a 7-mm-square image to a 24.5-mm image). This system is shown in Fig. 25. This new image is then collimated by a three-element lens system to give the appearance of an object at infinity. This collimator system is shown in Fig. 26. A camera lens mounted in front of the focal plane focuses the image. This increased object will create a larger image on the focal plane and allow for a larger test area.

When the first collimator system was designed, a spot size comparison was done. The spot size at the image plane in the lab was compared to values predicted by CODE V, with excellent results. A full comparison will not be possible in this case because the mismatch between the actual camera lens and the camera lens modeled in CODE V. The actual lens prescription of the camera lens attached to the focal plane is not known. A camera lens was selected from the CODE V library that best fit the input aperture, image size, and spot size of the actual camera lens. Although this gave good results for the original collimator system, when the DWSG output is increased to 3.5X, the CODE V camera lens is overfilled and is no longer a good approxima-

tion of the actual camera lens in use. The actual lens has a larger image plane and field of view when compared to the CODE V camera lens.

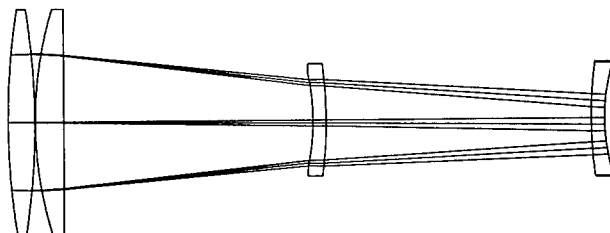

**Figure 25. Magnifier optics.**

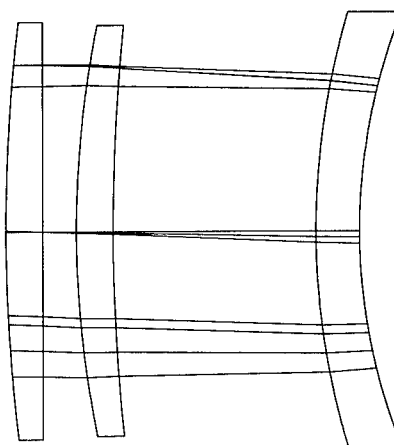

**Figure 26. Collimator optics for magnified system.**

Procurement for these optical systems has been initiated, and delivery is expected during the first quarter of FY97. Testing will be performed as soon as possible, and a marketing video showing the projection system in operation will be recorded.

As a separate design analysis, another scan lens design was produced which itself magnified the projection by a factor of 3.5, thus eliminating the need for a separate magnifier. The new scan lens design showed no improvement over the current magnifier system.

**5.0 CONCLUDING REMARKS**

For our future FPA and sensor test capability, it is recommended that the boards in the DWSG/DRES parallel processor architecture be rebuilt to separate the RF processors so that they become modular plug-in additions to the primary boards. Similar plug-in boards will be built for signal injection and heated mosaic array signal processing. This will provide a common scenario processing capability for the various stimulation equipment. Some of this effort is scheduled to be accomplished in the 0103 technology effort during FY97.

The projection of the DWSG through the optics of a simple sensor system has been satisfactorily achieved with and without the use of transmissive screens. The throughput is very much better in the no-screen case where the spot size is somewhat better as well. This indicates the potential utility of the DWSG for this type of testing.

Areas of further study are the possible limitations when using typical IR sensor systems, considering their field of view FOV and FPA metrics. Further analysis of the achievable spot size for projection which fully span the unit under test is also needed. The Gaussian shape of the beam should be included as a consideration in this study.

## REFERENCES

1. Jaenisch, Holger M., King, Jim, Scoggins, Jim, and Carroll, Marvin. "Simulating Landscapes Using an FFT Based Fractal Filter." Tec-Masters Inc., Huntsville, AL 35806.
2. Musgrave, Kenton, Kolb, Craig E., and Mace, Robert S. "The Synthesis and Rendering of Eroded Fractal Terrains." *Computer Graphics*, Vol. 23, No. 3, July 1989.
3. Lowry, H. S. and Elrod, P. D. "Completion of the Scene Generation Test Capability at AEDC." SPIE Orlando '95 9th International AeroSense Symposium and Conference, Vol. 2469, April 1995, pp. 30-41.
4. Lowry III, H. S., Tripp, D. M., Nicholson, R. A., Fugerer, R. H., Steely, S. L., and Holt, L. L. "Initial Test Efforts Using AEDC's Focal Plane Array Test Chamber." SPIE Orlando '96 10th International AeroSense Symposium and Conference, Session 2742, April 1996.
5. Steely, S. L., Fugerer, R. H., Lowry III, H. S., and Holt, L. L. "Direct Write Scene Generation Development Efforts for Closed-Loop Evaluation of Focal Plane Arrays." AEDC-TR-95-34, May 1996.
6. Steely, S. L., Lowry III, H. S., and Fugerer, R. H. "Laser-Based Direct Write Scene Generation Methods for Closed-Loop Focal-Plane-Array Diagnostics." SPIE Orlando '96, Vol. 2741, April 1996.
7. Steely, S. L., Fugerer, R. H., Lowry III, H. S., and Holt, L. L. "Optical Diagnostic Methods For Closed-Loop Focal Plane Array Evaluation: Anisoplanatic Optical Simulations Using Laser-Based Photonics." CLEO/QELS Conference, June 1996.
8. Kircher, J., Marlow, S. A., and Bastow, M. "Laser Scophony Infrared Scene Project." *Optical Engineering*, Vol. 33, No. 6, June 1994.