

Multi-Agent Intelligent Adaptive Coordinated Robotic System

Final Report

ONR Contract Number N00014-92-J-1647 AO8608

Prof. Ruzena Bajcsy, Director
GRASP Laboratory
Dept. of Computer & Information Science
University of Pennsylvania
Philadelphia, PA 19104

1 Project Objective

The objective of this project is to study cooperative behaviors in the framework of mobile manipulatory agents, observer agents and a human operator for semi-autonomous material handling in unstructured environments.

2 Approach

A direct impact of using distributed agents (which are cheaper, faster and lighter) is to perform tasks more reliably, in that a broken agent can be replaced by another, or the remaining agents can be reconfigured to carry out a task. Conventionally, physical interactions/contacts between agents are regarded as accidents and are avoided if at all possible. In this approach to multi-agent cooperation, physical interactions are positively exploited for the dual purposes of: (1) cooperative manipulation; and (2) communication. The information communicated through physical interactions includes the relative position/orientation, and interactive forces/moments. Sensing gives each agent independence, while communication is a prerequisite to cooperation. The assumption is that different agents, including the human agent, have different degrees of knowledge and views of the world with varied spatiotemporal resolution and capabilities of interaction. Agents ask for and take advice (communicated information), using it for control and completion of their task, unless they decide their sensory input is more appropriate for the given subtask.

This multi-agent robotic research project is subdivided into subtasks, each of which lead to a Ph.D. dissertation.

1. *Human Management of a Hierarchical System for the Control of Multiple Mobile Robots.*
Julie Adams.

In order to take advantage of autonomous robotic systems, and yet ensure successful completion of all feasible tasks, we propose a mediation hierarchy in which an operator can interact at all system levels. Robotic systems are not robust in handling un-modeled events. Reactive behaviors may be able to guide the robot back into a modeled state and to continue. Reasoning systems may simply fail. Once a system has failed it is difficult to re-start the

DISTRIBUTION STATEMENT A

Approved for public release;
Distribution Unlimited

19970311 085

task from the failed state. Rather, the rule base is revised, programs altered, and the task re-tried from the beginning.

Human-machine interfaces have been developed for applications in the areas of nuclear power plants, aviation, and telerobotics, however, these systems are generally not considered autonomous with the operator providing a "supervisory" role. Typically, the human operator controls the entire task execution.

One aspect of the system we are developing permits the human operator, when necessary, to interact with all levels of a system to assist with process errors. This interaction encompasses all areas of a semi-autonomous system from the processes which would be considered fully-autonomous to those considered telerobotic.

Our system, MASC - Multiple Agent Supervisory Control system, permits the agents to work autonomously until the human supervisor is requested to take control or detects a problem. Our design strategy is to develop a general system which is applicable to various robotic systems. We combine the advantages of autonomous systems with the human's ability to control a system through a human-machine interface. MASC provides the supervisor with tools to interact with all the robotic system processing levels. These interactions may correct corrupted data or process decisions which would typically cause an autonomous system to enter an unstable state. We desire to create a more comprehensive semi-autonomous system based on this interaction which will successfully complete the execution of task assignments.

We have defined four hierarchical levels of supervisory interaction with the various robotic system levels. MASC permits the supervisor to specify task assignments, teleoperate agents, display sensory data, override process conclusions and reconfigure the system during sundry sensory and agent failures.

2. A Framework for Modeling and Verifying Visually Guided Agents: Design, Analysis and Experiments.

Jana Košecká.

The successful functioning of robotic agents in a dynamically changing environment requires rich sensory input and advanced sensory-motor control. The robotic agents are typically equipped with multiple sensors and multiple actuators. The interactions between agents and the environment can be characterized by both discrete and continuous models. The accomplishment of various tasks is mediated by complex coordination and interaction between individual sensing and control strategies. It is crucial for the reliable and predictable operation of robotic systems that the design be within a structured methodology which supports analysis and modularity.

In this thesis we introduce a framework for modeling and verifying autonomous mobile agents which provides a unified approach to the design and analysis of systems comprising of both continuous and discrete event components. Our framework proposes to model elementary sensing and control strategies by making appropriate finite state machine abstractions which capture the discrete event aspects of continuous models.

In order to achieve the desired modularity and flexibility we define a *Task Specification Language* for composing elementary strategies to form more complex missions. The robustness

and reliability of individual control strategies is guaranteed by their design and analysis at the continuous level. The verification of the discrete event interactions between strategies is formulated as a Supervisory Control Theory Problem, where we synthesize a supervisor which serves as a run-time scheduler and monitor of the task.

The overall framework is verified in a series of experiments where teams of visually guided mobile agents are engaged in various navigation tasks. Within our framework, we formulate the visually guided navigation problem and propose a relational model of the environment embedded in a finite state machine structure which can then be used for automatic generation of the task specification.

3. Sensor Processing for Mobile Robot Localization, Exploration and Navigation.

Robert Mandelbaum.

In the context of a mobile robotic agent, we describe a unified framework for the competencies of localization, navigation, exploration and map-building. In this work, we focus on localization. We describe the design, implementation, testing and evaluation of data-processing algorithms for three sensor modalities: ultrasound, stereo vision and patterned light. We develop a sensor model for each modality. In each case, distinctive features of objects in the field of view are extracted. In each case, the output of the algorithm is of a form which facilitates integration within the framework, and hence the localization of the agent in a partially-known environment.

We delineate a computationally efficient method for sensor-based localization of a mobile robot based on planar features extracted using ultrasound. The method runs in time linear in the number of detected features, both for establishing correspondences between extracted and map features, and for pose estimation. We outline the extension of the localization algorithm to integrate the other sensor modalities.

Finally, we describe a method which, given an input of pose measurements by the sensor-based localization algorithm, produces the minimax risk fixed-size confidence set estimate for the pose of the mobile agent. The work in this dissertation constitutes the first application to the mobile robotics domain of optimal fixed-size confidence-interval decision theory. The approach is evaluated in terms of theoretical capture probability and empirical capture frequency during actual experiments with the mobile agent. The method is compared to several other procedures including the Kalman Filter (minimum mean squared error estimate) and the identity estimator which uses the measurement itself as the estimate. The minimax approach is found to dominate all the other methods in performance.

4. Local and Repeatable Coordination Schemes for Redundant Manipulators.

Chau-Chang Wang.

This thesis addresses the coordination of multiple degrees of freedom in redundant robot manipulators. A redundant manipulator is one that possesses more degrees of freedom than are necessary to accomplish the desired tasks. In such a system, the inverse kinematics problem or the problem of decomposing the desired end-effector movement into joint movements is underspecified. Therefore, it is possible to develop algorithms that optimize one or more performance indices while ensuring the desired end-effector movement. Most previous algorithms are based on local control laws which do not guarantee a repeatable solution.

In other words, if the end-effector traces a closed trajectory, such laws will not guarantee a closed trajectory in joint space.

The focus in this thesis is on a family of control laws that can be obtained by modeling a redundant manipulator as a hyperelastic, articulated kinematic chain. This approach is used to obtain local control laws as well as control laws that guarantee repeatability. The repeatable control scheme is plagued by algorithmic singularities. A method to determine these singularities is developed. These singularities are shown to correspond to instabilities in the corresponding hyperelastic structure when the structure is subject to force loading or displacement loading. An important theorem which relates the instabilities in force and displacement loading is proved. Finally, a screw-theoretic formulation yielding compact and computationally efficient solutions is developed.

The primary application considered in the thesis is a mobile manipulator and the problem of coordinating locomotion and manipulation. The efficacy of the proposed control schemes is demonstrated by computer simulations as well as experiments.

5. Control and Coordination of Locomotion and Manipulation of Wheeled Mobile Manipulators.

Yoshio Yamamoto.

In this thesis, we investigate modeling, control, and coordination of mobile manipulators. A mobile manipulator in this study consists of a robotic manipulator and a mobile platform, with the manipulator being mounted atop the mobile platform. A mobile manipulator combines the dextrous manipulation capability offered by fixed-base manipulators and the mobility offered by mobile platforms. While mobile manipulators offer a tremendous potential for flexible material handling and other tasks, at the same time they bring about a number of challenging issues rather than simply increase the structural complexity. First, combining a manipulator and a platform creates redundancy. Second, a wheeled mobile platform is subject to nonholonomic constraints. Third, there exists dynamic interaction between the manipulator and the mobile platform. Fourth, manipulators and mobile platforms have different bandwidths. Mobile platforms typically have slower dynamic response than manipulators. The objective of the thesis is to develop control algorithms that effectively coordinate manipulation and mobility of mobile manipulators.

We begin with deriving the motion equations of mobile manipulators. The derivation present here makes use of the existing motion equations of manipulators and mobile platforms, and introduces the velocity and acceleration dependent terms that account for the dynamic interaction between manipulators and mobile platforms. Since nonholonomic constraints play a critical role in control of mobile manipulators, we then study the control properties of nonholonomic dynamic systems, including feedback linearization and internal dynamics. Based on the newly proposed concept of preferred operating region, we develop a set of coordination algorithms for mobile manipulators. While the manipulator performs manipulation tasks, the mobile platform is controlled to always bring the configuration of the manipulator into a preferred operating region. The control algorithms for two types of tasks – dragging motion and following motion – are discussed in detail. The effects of the dynamic interaction are also investigated.

To verify the efficacy of the coordination algorithms, we conduct numerical simulations with representative task trajectories. Additionally, the control algorithms for the dragging motion and following motion have been implemented on an experimental mobile manipulator. The results from the simulation and experiment are presented to support the proposed control algorithms.

6. *Stability of Grasped Objects: Beyond Force Closure.*

William Stamps Howard, IV.

This dissertation addresses the stability and compliance of grasped objects through the derivation of the stiffness matrix associated with each grasp. A grasped object is defined to be in equilibrium if the sum of all forces acting on a body equals zero and the sum of all moments acting on a body also equals zero. An equilibrium grasp may be stable or unstable. Force closed grasps are a well-known subset of equilibrium grasps and have the important property of being stable. However, not all stable grasps are force closed, including many common and easily obtainable grasps. In this dissertation, a general framework is established for the determination of grasp stability. Simple, easily applicable criteria are derived to determine the stability of any grasp, including the special but important limiting case of rigid bodies.

In order to analyze the stability of grasps with multiple contacts, the compliances at each contact is modeled. The model includes the effect of such parameters as curvatures of the contacting surfaces, kinematics of the grasping fingers, internal forces, and compliance of the fingers and joints on the performance of the system. The methodology also allows the grasping fingers to be modeled as either compliant or rigidly fixed in space. Expressions are then developed for the changes in contact forces as a function of the rigid body motion of the grasped object. From this, the stability of a grasp is shown to depend on the local curvature of the contacting bodies, as well as the magnitude and arrangement of the contact forces. A large number of examples are presented, including applications in automated fixturing.

Finally, the asymmetry of Cartesian stiffness matrices in a conservative system is examined. Methods of differential geometry and properties of Lie groups are used to show that any conservative system subjected to a non-zero external load, the resulting Cartesian stiffness matrix may be asymmetric whenever the basis vector utilized are not derived from generalized coordinates, in any inertial or body-fixed reference frame. However, a reference frame is found which always generates a symmetric stiffness matrix.

3 The Multi-agent Testbed

The GRASP Laboratory has developed a hardware-software testbed for studying tradeoffs between sensing and communication in multi-agent robotic systems. Tradeoffs between task execution time, task execution reliability, system cost, and system reconfigurability are also considered. Reconfiguring multi-agent robotic systems by distributing the sensing subtasks among several agents and using low-bandwidth communications channels to communicate task-specific symbolic information provides the system user with a significantly more reliable

system. The testbed includes:

1. Two observer robots (Figure 1) with multiple non-contact sensing modalities for obstacle avoidance and navigation.

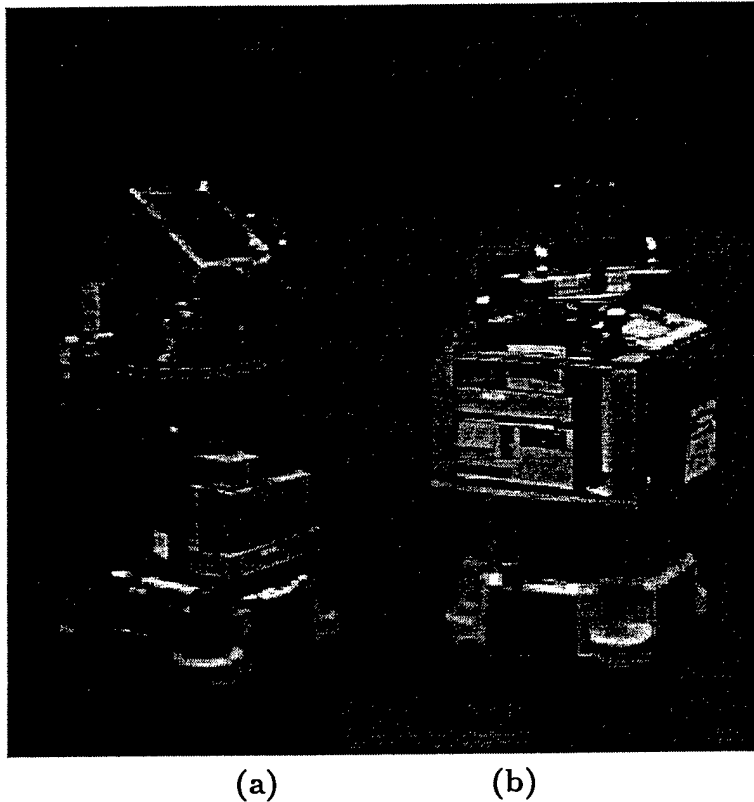

Figure 1: (a) Observation agent A “sensorbot” with four sensor modalities: ultrasound, stereo pair, patterned light and dead reckoning, and (b) Observation agent B “visionbot” with two sensor modalities: inverse perspective projection and dead reckoning.

With “sensorbot,” a framework has been developed to control confluence and integration of heterogeneous sensor data, thereby developing sensor modalities in a modular fashion while enabling cooperation on a system level. Ultrasound is used to extract geometric information and check correspondence with world map. Agent localization is embedded in formalism of local confidence estimation, which predicts tradeoffs between amount of precision in localization afforded by detecting more features versus uncertainty of location incurred by moving to detect the features. Reconfiguring multi-agent systems by distributing sensing subtasks and using low-bandwidth channels to communicate task-specific information yields a more reliable system.

With “visionbot,” a framework has been developed in which the Discrete Event System (DES) formalism is connected with the task specification language, enabling easy incorporation of heterogeneous agents and the human operator. Low-level control uses continuous control methods; mid-level control uses the DES formalism; high-level control uses the task specification language. The DES supervisory control system arbitrates between conflicting control subtasks for a given task requirement. Our approach to modeling and composition

of agents' behavior and communication guarantees overall system controllability, provided assumptions about the environment are correct. If not, a failure mode is initiated, i.e., error recovery behaviors are invoked or the human operator assists.

2. Two mobile manipulators (Figure 2), which provide for cooperative manipulation and transport of non-compact objects. The two manipulatory agents employ a fixtureless grasp to carry an object. By using multiple manipulators equipped with sensors, agents can grasp arbitrarily shaped objects without specially-shaped end effectors. We have developed algorithms for optimal control while carrying an object and automatic agent/manipulator reconfiguration.

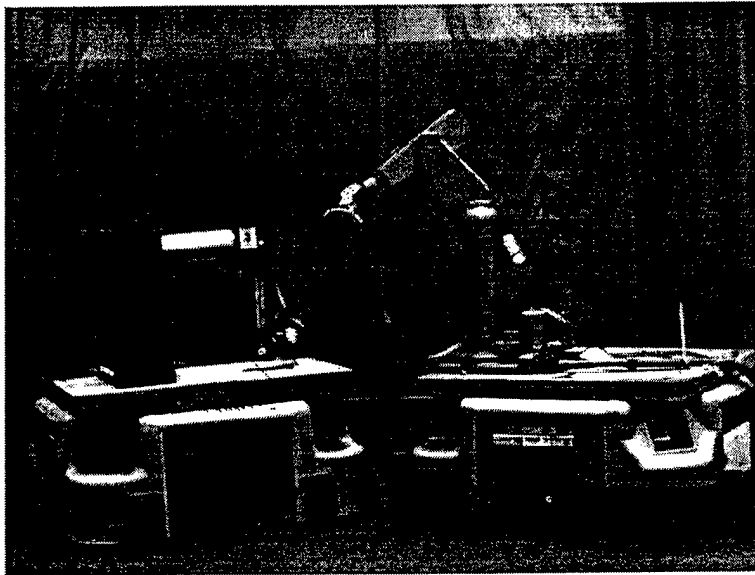

Figure 2: Two manipulatory agents.

3. One human operator interface (Figure 3). The Multi-agent Supervisory Control System provides world model generation and maintenance, and graphical display of multisensory data from robotic agents, enabling the human operator to interact with all levels of the robotic system.

The testbed, depicted schematically in Figure 4, is flexible enough for adding or turning off processes, and studying the tradeoffs between sensing versus a priori models and their effects on performance, including statistical analysis of process outcomes and task reliability. The complexity of this testbed and corresponding benchmarking of team cooperative behaviors can be characterized by the following measures:

- We have 4 mobile platforms, with 8 actuators, 2 manipulators, 6 different sensory modalities, and 4 processes per agent.
- The human operator interface and cameraServer provides the human agent with images when not running with any of the other sensory processes.
- The high-level software of the human operator interface alone is composed of 34 *.c, and 33 *.h files.

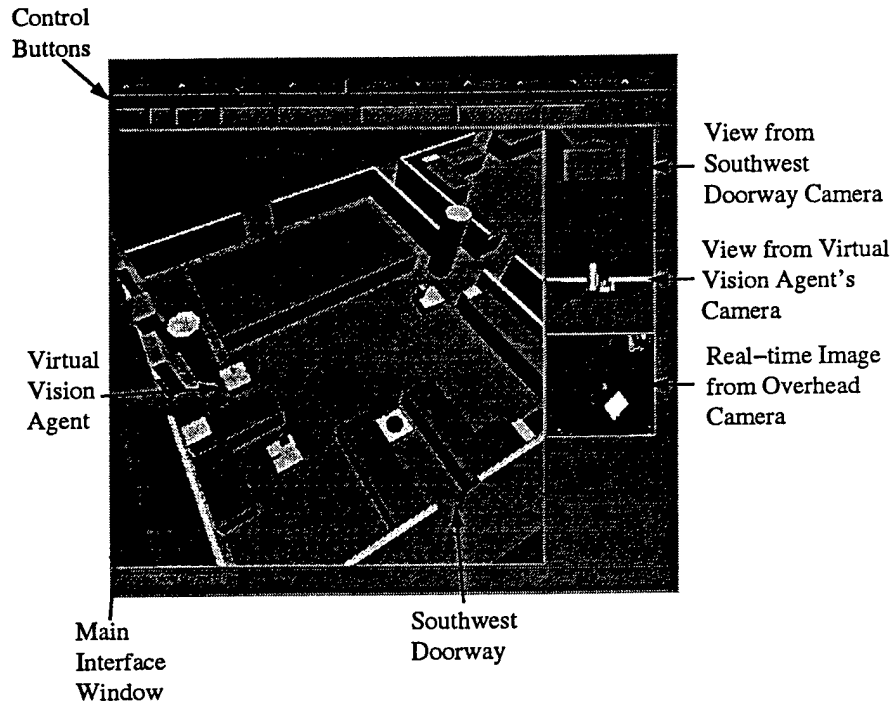

Figure 3: The Multi-agent Supervisory Control System.

- The human operator interface currently communicates with 12 external processes.
- We run three different hardware platforms (PC, SGI and SUN).
- We have heterogeneous connections that vary for different tasks, with speeds ranging from 5 HZ up to 250 HZ. The interconnection possibilities are four factorial, selected automatically based on the dynamics of the task.

4 Project Development

4.1 June 1992 – June 1993

1. Development of human operator interface using SGI's inventor software. This approach did not work.
2. Development of hardware and basic interfacing software for ultrasound sensor, patterned light device and platform controllers.
3. Design of novel sensor processing and clustering strategies with real-time performance for ultrasound, patterned light and vision modalities. Strategies address the tasks of map-building, basic navigation and obstacle avoidance.
4. Development and implementation of a control and planning algorithm for coordinating locomotion and manipulation of a single mobile manipulator.

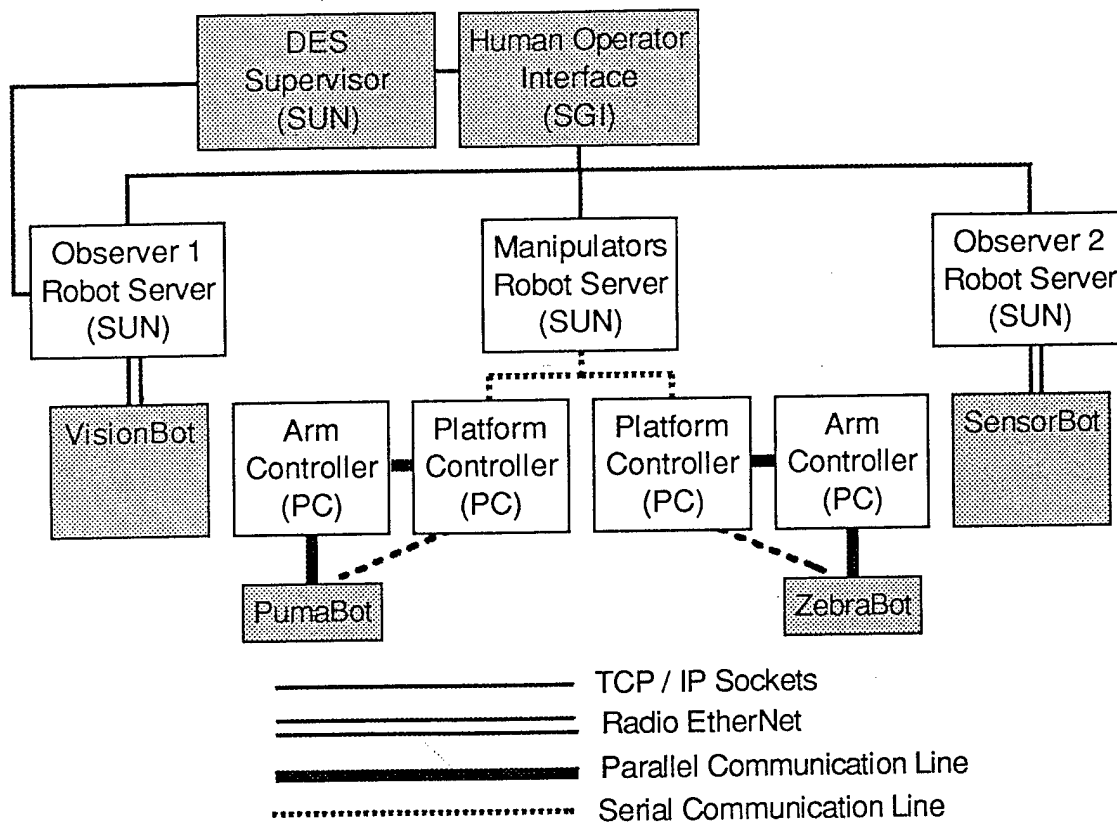

Figure 4: Schematic depiction of the multi-agent testbed.

4.2 June 1993 – June 1994

1. Development of the human operator interface, including: (i) initial interface development using Sayer's PENGUIN software; (ii) display of raw sonar and ultrasound; (iii) development of teleoperation to create commands; (iv) creation of overhead process to add objects to the model; (v) integration of local path planner; (vi) formal development of the mediation hierarchy theory; (vii) integration of Stanford's Global path planner; (viii) integration of Obstacle Avoidance processes; (ix) development of control for the four agents (pausing, stopping or continuing command execution); and (x) development of system replay for problem situations.
2. Development of algorithms for coordinating two manipulators while adapting to external loading and maintaining desired contact conditions (e.g., force closure).
3. Development of an algorithm for controlling a mobile manipulator while applying a controlled force to a moving object.
4. Development of a procedure for allocating end-effector motion between the base and the manipulator to solve the problem of kinematic redundancy for mobile manipulators.
5. Development of primitives for mobile manipulator controllers, (e.g., Point_to_Point shortest path generation).

6. Further design and implementation of elementary sensor strategies with real-time performance for multiple sensors for exploration, building world models, and localization, and preliminary evaluation of performance.
7. Design framework for integration of multiple sensor modalities for localization and navigation.
8. Design, development and implementation of a large-scale distributed system. Team consists of four heavy-duty agents with heterogeneous capabilities interacting with the human agent. The team boasts seven sensing modalities, including two vision-based sensors, a patterned-light device, infra-red proximity sensors, ultrasound range detectors, force/torque sensors and odometry. Each team member consists of multiple processes running in parallel.
9. Development of asynchronous protocols for inter-process as well as inter-agent communication using UNIX sockets, serial lines and parallel line to cope with the vagaries of a generalized, variegated, heterogeneous system.

4.3 June 1994 – April 1995

1. Development of the human operator interface, including: (i) further development of replay mode; (ii) development of waypoint specification for path following; (iii) integration of ultrasound process; (iv) integration of puma and zebra robots; (v) task execution with all agents; and (vi) attempt to integrate stereo process.
2. As means of specifying tasks and consequently verifying properties of the system, a process oriented task specification language was proposed and defined, which captures well all temporal and logical dependencies between the processes on the distributed system, and enables communication/cooperation between agents.
3. Continuing testing and evaluation of performance of sensor processing algorithms.
4. Implementation of real-time localization algorithm using ultrasound modality. Design and development of a system for establishing ground truth to enable quantitative evaluation of the localization algorithm. Implementation of framework to combine data from multiple modalities for the task of localization.
5. Continuing refinement and evolution of distributed system and associated communication protocols to accommodate increasing complexity.
6. Development of algorithms that enable two or more agents to march in formation while maintaining a fixed separation distance and relative orientation and a method to analyze the performance of such multiagent convoys.
7. Development of hybrid agents able to use their arms for locomotion and to surmount obstacles.

4.4 April 1995 – August 1996

1. Development of algorithms that enable two agents to reconfigure while cooperatively transporting an object.
2. Human factors testing and analysis of the human operator interface.
3. Integration and experimental verification of the multi-agent system, involving the following experiments:
 - (a) Human agent prescribes path to all agents and they follow it. No obstacles are in the path.
 - (b) Human agent prescribes path to all agents, but (unknown to the human agent) obstacle appears in the path.
 - (c) Human agent prescribes path to all agents, which includes narrow passageway requiring the two manipulatory agents to reconfigure.

Four mobile autonomous agents marching in various formations is depicted in Figure 5. (The human agent supervision and assistance is not shown.) Agents are able to avoid obstacles, carry large objects and reconfigure themselves while holding the object being carried. This scenario has been experimentally carried out in the GRASP Laboratory. Furthermore, this scenario was remotely demonstrated at the DARPA SISTO Software Technology and Intelligent Systems Symposium in August, 1995 where the human operator (at the demo site in Chantilly, VA) supervised and assisted the four robotic agents in the GRASP Lab using the Multi-agent Supervisory Control System.

4. Benchmark team cooperative behavior.

5 Conclusion

5.1 Results

- We have implemented a cooperative small team multi-agent architecture and testbed for transporting non-compact objects through obstacle-laden environments.
- System capabilities include interaction between a human agent, two mobile manipulatory agents and two observer agents with multiple non-contact sensing modalities for path planning and replanning, obstacle detection and avoidance, payload and agent reconfiguration, and error diagnosis and recovery.
- Four mobile autonomous agents are able to march in various formations under human supervision and assistance, autonomously avoiding obstacles, carrying large objects, and reconfiguring while holding the object.

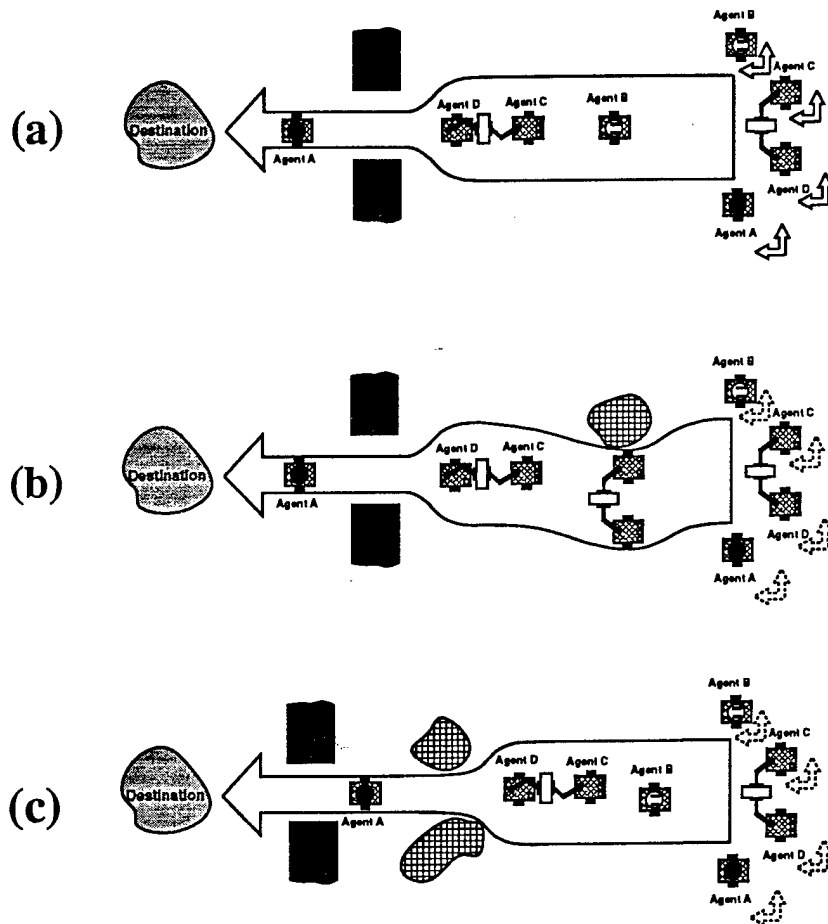

KEY:

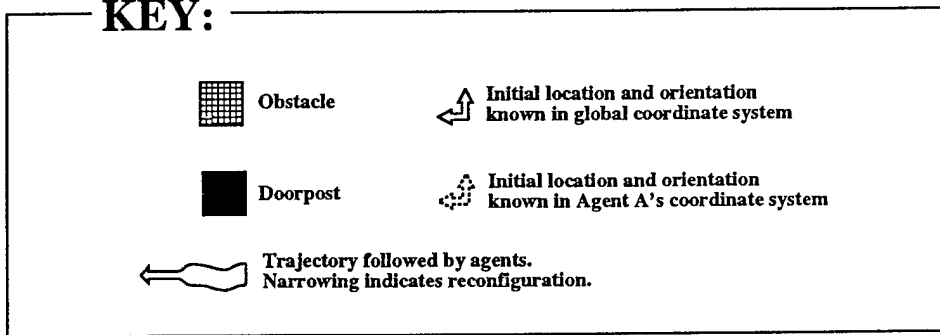

Figure 5: Graphical representation of three experimental scenarios. (a) Agents' initial locations and orientations are known; no obstacles encountered; manipulatory agents undergo scheduled reconfiguration to pass through doorway. (b) Agents' relative initial locations and orientations are known; Agent A performs global localization; an obstacle causes deviation from planned path; manipulatory agents undergo a scheduled reconfiguration to pass through a doorway. (c) Agents' relative initial locations and orientations are known; Agent A performs global localization; multiple obstacles warrant unscheduled reconfiguration of manipulatory agents.

5.2 Lessons Learned

- Cooperative testbeds are necessary to learn about and test the robustness of system components.
- Design and development of a mediation hierarchy as part of the human agent interface allows the human agent to interact with the whole system at any level as needed.
- The human agent is necessary for successful operation of a multi-agent system for cooperative material handling. This approach exploits human expertise for aspects of task planning and monitoring, and error recovery.
- Partitioning robotic agents into two classes provides useful degrees of freedom in experimental design, allowing for systems with greater ability to observe agents working near obstacles or one another.
- The application of potential functions has shown the value of this approach in controlling motion of multiple vehicles in obstacle-laden environments. Motions obtained exhibit good stability and smoothness.
- Embedding the overall system in the DES formalism connected with a task specification language allows for easy incorporation of heterogeneous agents and a human operator.
- A salient aspect of our DES supervisory control system is its ability to arbitrate between conflicting control subtasks within a given task requirement.
- No one sensing modality can provide sufficient data about the environment for execution of all tasks; thus, sensory integration of multiple modalities is essential.
- One observer agent can localize itself and other agents using a feature-based strategy embedded in the formalism of local confidence estimation, which predicts tradeoffs between precision in localization afforded by detecting more features versus uncertainty of location incurred by moving to detect features.
- Integrating heterogeneous computers running at various speeds with different operating systems and inter-connections is very difficult and should never be underestimated!
- There is a stiff penalty for system integration. The lack of standardized off-the-shelf customized subsystems is a hindrance.
- Perception is the main bottleneck! Assumptions and limitations resulting from the system's perceptual capabilities determine total system performance and influence reasoning and communication capabilities.

6 Selected Publications

1. J.A. Adams. *Human Management of a Hierarchical Control System for Multiple Mobile Robots*. Dissertation. Dept. of Computer and Information Science, University of PA, Philadelphia, PA, MS-CIS-95-17, GRASP Lab 392, 1995.
2. J. Adams, R. Bajcsy, J. Kosecka, V. Kumar, R. Mandelbaum, M. Mintz, R. Paul, C.-C. Wang, Y. Yamamoto and X. Yun. Cooperative Material Handling by Human and Robotic Agents: Module Development and System Synthesis. *Proc. Int'l. Conf. on Intelligent Robots and Systems*, Pittsburgh, PA, Aug. 5-9, 1995.
3. J. Adams, R. Bajcsy, J. Kosecka, V. Kumar, R. Mandelbaum, M. Mintz, R. Paul, C.-C. Wang, Y. Yamamoto and X. Yun. *Cooperative Material Handling by Human and Robotic Agents: Module Development and System Synthesis*. Technical Report, Dept. of Computer and Information Science, University of PA, MS-CIS-95-01, GRASP LAB 385.
4. J. Adams, R. Bajcsy, J. Kosecka, V. Kumar, R. Mandelbaum, M. Mintz, R. Paul, C.-C. Wang, Y. Yamamoto and X. Yun. Cooperative Material Handling by Human and Robotic Agents: Task Description and Experiments. *IROS Workshop on Computer Vision*, Pittsburgh, PA, Aug. 4, 1995.
5. J.A. Adams and R. Paul. Human-Managed, Hierarchical Control of Multiple Mobile Agents. *Proc. IEEE Conf. on Decision and Control*, Dec. 1994.
6. J.A. Adams and R. Paul. Human Management of a Hierarchical Control System for Multiple Mobile Robots. *Proc. IEEE Int'l. Conf. on Systems, Man and Cybernetics*, Oct. 1994.
7. J.A. Adams and R. Paul. Human Supervisory Control of Multiple Mobile Robots. *Proc. of the 1995 IEEE Int'l. Conf. on Systems, Man and Cybernetics*, Oct. 1995, Vancouver, BC Canada.
8. R. Bajcsy. From Active Perception to Active Cooperation — Fundamental Processes of Intelligent Behavior. In *Visual Attention and Cognition*, W.H. Zangemeister, H.S. Stiehl, C. Freksa (eds.), Vol. 116 of Advances in Psychology series, Elsevier, Amsterdam, 1996.
9. R. Bajcsy. Signal-to-Symbol Transformation and vice versa: From Fundamental Processes to Representation. *ACM Computing Surveys AI Symp.*, Vol. 27, No. 3, Sept. 1995.
10. R. Bajcsy and J. Kosecka. The Problem of Signal and Symbol Integration: A Study of Cooperative Mobile Autonomous Agents Behaviors. *19th Annual German Conf. on Artificial Intelligence*, Bielefeld, Germany, Sept. 11-13, 1995.
11. R. Bajcsy and H.-H. Nagel. Descriptive and Prescriptive Languages for Mobility Tasks: Are They Different? *Advances in Image Understanding: A Festschrift for Azriel Rosenfeld*, K. Bowyer and N. Ahuja (eds.), IEEE Computer Society Press, 1996.

12. C.-H. Chen and V. Kumar. Motion Planning of Walking Robots in Environments with Uncertainty. *Proc. IEEE Int'l. Conf. on Robotics and Automation*, Minneapolis, MN, April 1996, pgs. 3277-3282.
13. J. Desai, C.-C. Wang, M. Zefran and V. Kumar. Motion planning of multiple mobile manipulators. *Proc. IEEE Int'l. Conf. on Robotics and Automation*, Minneapolis, MN, April 23-27, 1996.
14. J. Donoghue, W.S. Howard and V. Kumar. Stable Workpiece Fixturing. *23rd Biennial ASME Mechanisms Conf.*, Minneapolis, MN, Sept. 12-14, 1994.
15. W.S. Howard. *Stability of Grasped Objects: Beyond Force Closure*. Dissertation. Dept. of Mechanical Engineering and Applied Mechanics, University of PA, Philadelphia, PA, 1995.
16. W.S. Howard and V. Kumar. A Minimum Principle for the Dynamic Analysis of Systems with Frictional Contacts. *IEEE Int'l. Conf. on Robotics and Automation*, Atlanta, GA, May 2-7, 1993.
17. W.S. Howard and V. Kumar. Kinematics and Stability of Grasps with Compliant Contacts. *IEEE Int'l. Conf. on Robotics and Automation*, May 8-13, 1994, San Diego, CA.
18. W.S. Howard and V. Kumar. Modeling and Analysis of the Compliance and Stability of Enveloping Grasps. *Proc. IEEE Int'l. Conf. on Robotics and Automation*, Nagoya, Japan, May 1995.
19. W.S. Howard, M. Zefran and V. Kumar. On the 6x6 stiffness matrix for three dimensional motions. *9th World Congress of the IFToMM*, Milano, Italy, Aug. 30 - Sept. 2, 1995.
20. G. Kamberova and M. Mintz. Fixed Size Confidence Intervals for Non-MLR Location Problems. *227th meeting of the Institute of Mathematical Statistics*, Philadelphia, PA, March 21-24, 1993.
21. G. Kamberova and M. Mintz. *Minimax Rules Under Zero-One Loss for a Restricted Location Parameter*. GRASP LAB Technical Report 404, Department of Computer and Information Science, University of PA, Philadelphia, PA.
22. R. Kennedy and M. Mintz. Minimax Estimation Under Multilevel Loss. *227th meeting of the Institute of Mathematical Statistics*, Philadelphia, PA, March 21-24, 1993.
23. J. Kosecka. *A Framework for Modeling and Verifying Visually Guided Agents: Design, Analysis and Experiments*. Dissertation. Dept. of Computer and Information Science, University of PA, Philadelphia, PA, GRASP Lab 402, 1996.
24. J. Kosecka and R. Bajcsy. Cooperation of Visually Guided Behaviors. *Proc. Int'l. Conf. on Computer Vision*, pp. 509-506, May 1993.

25. J. Kosecka and R. Bajcsy. Discrete Event Systems for Autonomous Mobile Agents. *Robotics and Autonomous Systems*, 12(1994) 187-198.
26. J. Kosecka, R. Bajcsy and H.I. Christensen. Discrete Event Modeling of Navigation and Gaze Control. *Int'l. Jrnl. of Computer Vision*, special issue on Qualitative Vision, Vol. 14, No. 2, pages 179-191, March 1995.
27. J. Kosecka, R. Bajcsy and M. Mintz. Control of Visually Guided Behaviors. In *Real-time Computer Vision*, C. Brown and D. Terzopoulos, eds., Cambridge University Press, 1994. Also appears as Technical Report, Dept. of Computer and Information Science, University of PA, MS-CIS-93-101, GRASP LAB 367.
28. J. Kosecka and L. Bogoni. Application of Discrete Events Systems for Modeling and Controlling Robotic Agents. *Proc. Int'l. Conf. on Robotics and Automation*, San Diego, CA, 1994.
29. V. Kumar. Characterization of Workspaces of Parallel Manipulators. *ASME Jrnl. of Mechanical Design*, Vol. 114, No. 3, 1992, pp. 368-375.
30. V. Kumar. A Compact Inverse Velocity Solution for Redundant Robots. *Int. Jrnl. of Robotics Research*, Vol. 12, No. 1, Feb. 1993.
31. V. Kumar. Instantaneous Kinematics of Parallel-Chain Robotic Mechanisms. *ASME Jrnl. of Mechanisms, Transmissions, Automation in Design*, Vol. 114, No. 3, 1992, pp. 349-358.
32. E. Large, H.I. Christensen and R. Bajcsy. *Scaling the Dynamic Approach to Path Planning and Control: Competition among Behavioral Constraints*. GRASP LAB Technical Report 409, Department of Computer and Information Science, University of PA, Philadelphia, PA.
33. R. Mandelbaum. *Sensor Processing for Mobile Robot Localization, Exploration and Navigation*. Dissertation. Dept. of Computer and Information Science, University of PA, Philadelphia, PA, GRASP Lab 399, 1996.
34. R. Mandelbaum and M. Mintz. Active Sensor Fusion for Mobile Robot Exploration and Navigation. *Proc. SPIE Conf. on Sensor Fusion*, Vol. 2059, 7 Sept. 1993, pp. 130-141.
35. R. Mandelbaum and M. Mintz. Feature-Based Localization using Fixed Ultrasonic Transducers. *Proc. Int'l. Conf. on Intelligent Robots and Systems*, Pittsburgh, PA, Aug. 5-9, 1995.
36. R. Mandelbaum and M. Mintz. Sonar Signal Processing Using Tangent Clusters. *OCEANS '94*, special session on Automated Unmanned Vehicles, sponsored by the IEEE Oceanic Engineering Society and the French Societe des Electriciens et Electroniciens, Sept. 1994.

37. R. Mandelbaum and M. Mintz. Stereo-Based Region-growing using String Matching. *Proc. Int'l. Conf. on Integrated Micro-Nanotechnology for Space Applications*, Houston, TX, Nov. 1995.
38. R. McKendall and M. Mintz. Sensor-Fusion with Statistical Decision Theory: A Prospectus. In *Data Fusion in Robotics and Machine Intelligence*, Edited by M. Abidi, Academic Press, 1992, pp. 211-244.
39. E. Paljug and X. Yun. Experimental Study of Two Arms Manipulating Large Objects. *1993 IEEE Int'l. Conf. on Robotics and Automation*, May 2-7, 1993, Atlanta, GA, Vol. 1, pp. 517-522.
40. R. Paul, C. Sayers and J. Adams. Operator Control of Robotic Systems. *Proc. Seventh Int'l. Symp. on Robotics Research*, G. Giralt and G. Hirzinger (Eds.), Springer-Verlag, Herrsching, Germany, Oct. 21-24, 1995.
41. N. Sarkar, X. Yun and V. Kumar. Control of a Single Robot in a Cooperative Multiagent Framework. *Int'l. Conf. on Intelligent Robots and Systems*, July 26-30, 1993, Yokohama, Japan.
42. N. Sarkar, X. Yun and V. Kumar. Control of Mechanical Systems with Rolling Constraints: Applications to Dynamic Control of Mobile Robots. *Int'l. Jnl. of Robotics Research*, Vol. 13, No. 1, Feb. 1994.
43. N. Sarkar, X. Yun and V. Kumar. Control of Rolling Contacts in Two-Arm Manipulation. *IEEE Int'l. Conf. on Robotics and Automation*, Atlanta, GA, May 2-7, 1993.
44. N. Sarkar, X. Yun and V. Kumar. Dynamic Control of a Robot in a Multiagent Framework. *IEEE Int'l. Conf. on Robots and Intelligent Systems*, Tokyo, Japan, June 1993.
45. N. Sarkar, X. Yun and V. Kumar. Dynamic Control of 3-D Rolling Contacts for Two-Arm Manipulation. *1993 IEEE Int'l. Conf. on Robotics and Automation*, May 2-7, 1993, Atlanta, GA, Vol. 3, pp. 978-983.
46. N. Sarkar, X. Yun and V. Kumar. Dynamic Path Following: A New Control Algorithm for Mobile Robots. *32nd IEEE Int'l. Conf. on Decision and Control*, San Antonio, TX, Dec. 15-17, 1993.
47. N. Sarkar, X. Yun and V. Kumar. Velocity and Acceleration Analysis of Contact Between Three-Dimensional Rigid Bodies. *Proc. ASME Mechanisms Conf.*, Minneapolis, MN, 1994.
48. C. Sayers, R. Paul and M. Mintz. Interacting with Uncertainty. *Telemanipulator Technology*, SPIE Proc. Vol. 1833, 1992.
49. C.-C. Wang. *Local and Repeatable Coordination Schemes for Redundant Manipulators*. Dissertation. Dept. of Mechanical Engineering and Applied Mechanics, University of PA, Philadelphia, PA, 1995.

50. C.-C. Wang and V. Kumar. The Performance of Repeatable Control Schemes. *Proc. IEEE Int'l. Conf. on Robotics and Automation*, Nagoya, Japan, May 1995.
51. C.-C. Wang and V. Kumar. Velocity Control of Mobile Manipulators. *IEEE Int'l. Conf. on Robotics and Automation*, Atlanta, GA, May 2-7, 1993.
52. C.-C. Wang, N. Sarkar and V. Kumar. Rate Kinematics of Mobile Manipulators. Robotics, Spatial Mechanisms, and Mechanical Systems, ASME Pub. no. DE-Vol. 46, Eds. Kinzel et al. *Proc. 22nd Biennial ASME Mechanisms Conf.*, Phoenix, AR, 1992, pp. 225-232.
53. Y. Wang and V. Kumar. Simulation of Mechanical Systems with Unilateral Constraints. Mechanism Design and Synthesis, ASME Pub. no. DE-Vol. 46, Eds. Kinzel et al. *Proc. 22nd Biennial ASME Mechanisms Conf.*, Phoenix, AR, 1992, pp. 129-134.
54. Y. Yamamoto. *Control and Coordination of Locomotion and Manipulation of a Wheeled Mobile Manipulator*. Dissertation, Dept. of Computer and Information Science, University of PA, Philadelphia, PA, MS-CIS-94-39, GRASP LAB 377, 1994.
55. Y. Yamamoto and X. Yun. A Control Algorithm for Mobile Manipulators Using the Preferred Operating Region. *IEEE/Nagoya University World Wisemen Workshop (WWW) on Multiple/Distributed Robotic Systems*, July 30-31, 1993, Nagoya, Japan.
56. Y. Yamamoto and X. Yun. Control of Mobile Manipulators Following a Moving Surface. *1993 IEEE Int'l. Conf. on Robotics and Automation*, May 2-7, 1993, Atlanta, GA, Vol. 3, pp. 1-6.
57. Y. Yamamoto and X. Yun. Coordinating Locomotion and Manipulation of a Mobile Manipulator. *31st IEEE Int'l. Conf. on Decision and Control*, Tucson, AR, Dec. 16-18, 1992, pp. 2643-2648.
58. Y. Yamamoto and X. Yun. Coordinating Locomotion and Manipulation of a Mobile Manipulator. *IEEE Trans. on Automatic Control*, Vol. 39, No. 6, pp. 1326-1332, June 1994.
59. Y. Yamamoto and X. Yun. Coordinating Locomotion and Manipulation of a Mobile Manipulator. *Recent Trends in Mobile Robots*, edited by Yuan F. Zheng, World Scientific Publisher, 1994.
60. Y. Yamamoto and X. Yun. Modeling and Compensation of the Dynamic Interaction of a Mobile Manipulator. *1994 IEEE Int'l. Conf. on Robotics and Automation*, May 8-13, 1994, San Diego, CA.
61. X. Yun. Dynamic State Feedback Control of Two Cooperative Manipulators. *Int'l. Jrnl. of Systems Science*, Vol. 24, No. 5, 1993, pp. 915-928.
62. X. Yun. Object Handling Using Two Arms Without Grasping. *Int'l. Jrnl. of Robotics Research*, Vol. 12, No. 1, pp. 99-106, Feb. 1993.

63. X. Yun and Y. Yamamoto. Internal Dynamics of a Wheeled Mobile Robot. *Int'l. Conf. on Intelligent Robots and Systems*, July 26-30, 1993, Yokohama, Japan.
64. M. Zefran and V. Kumar. Coordinate-Free Formulation of the Cartesian Stiffness Matrix. *Int'l. Symp. on Advances in Robot Kinematics*, Portoroz, Slovenia, 1996.
65. M. Zefran and V. Kumar. On the generation of smooth three-dimensional rigid body motions. *Workshop on Computational Kinematics*, Sophia-Antipolis, France, Sept. 4-7, 1995.
66. M. Zefran and V. Kumar. Optimal control of systems with unilateral constraints. *Proc. IEEE Int'l. Conf. on Robotics and Automation*, Nagoya, Japan, May 1995.
67. M. Zefran and V. Kumar. Planning smooth motions on $SE(3)$. *IEEE Int'l. Conf. on Robotics and Automation*, Minneapolis, MN, April 23-27, 1996.
68. M. Zefran, V. Kumar, J. Desai and E. Henis. Two-Arm Manipulation: What can we learn by studying humans? *Proc. Conf. on Intelligent Robot Systems*, Pittsburgh, PA, 1995.
69. M. Zefran, V. Kumar and X. Yun. Optimal Trajectories and Force Distribution for Cooperative Manipulation Tasks. *IEEE Int'l. Conf. on Robotics and Automation*, May 8-13, 1994, San Diego, CA.